

T I P S • T O O L S • T E C H N I Q U E S

# ShopNotes™

\$4.95

Issue 2



- Wooden Joiner's Mallet
- Hand-Cut Mortises

- Storage Bin System
- Radial Arm Saw Fence



# ShopNotes

Issue 2

March 1992

**EDITOR** Donald B. Peschke

**EDITORIAL DIRECTOR** Douglas L. Hicks

**MANAGING EDITOR** Terry J. Strohmman

**ASSISTANT EDITORS** Richard S. Peters  
Tim Robertson

**CREATIVE DIRECTOR** Ted Kralicek

**ASST. ART DIRECTOR** Cary Christensen

**ILLUSTRATOR** Kurt Schultz

**CONTRIBUTING ILLUS.** Chris Glowacki  
Robert H. Whitmer

**DESIGN DIRECTOR** Ken Munkel

**DESIGNER** Jan Hale Svec

**PHOTOGRAPHER** Crayola England

**SHOP MANAGER** Steve Curtis

**CIRCULATION DIRECTOR** Liz Bredeson

**SUBSCRIPTION MANAGER** Phyllis Jessen

**CIRCULATION ANALYST** Jim Woodson

**NEWSSTAND SALES** Kent A. Buckton

**CONTROLLER** Paul E. Gray

**ACCOUNTING** Linda O'Rourke

**BOOKEEPING** Julianne Spears

**NETWORK ADMIN.** Douglas M. Lidster

**ADMINISTRATIVE ASST.** Cheryl Scott

**RECEPTIONIST** Lori Seibert

**BUILDING MAINTENANCE** Ken Griffith

**MARKETING DIRECTOR** Robert Murry

**SHOP SUPPLIES ART DIR.** Cindy Jackson

**CUSTOMER SERVICE MGR.** Laura McNelly

**PROJECT SUPPLIES** Leslie Ann Gearhart  
Linda Jones

**TECHNICAL SUPPORT** Jonathan Garbison

**SYSTEMS OPERATOR** Linda Morrow

**RECEPTIONIST** Keri Lee

#### CUSTOMER SERVICE

Jennie Enos (Supr.), Joy Johnson, Tammi Juhl, Marci Nelson, Doug Neathery, Jeff Janes, Sara Johnson, Chris Lo

#### SHIPPING DEPARTMENT

Jerry Carson (Supr.), Gloria Sheehan, Ronald Long, Donnie McVey, Chuck Carlson

ShopNotes is published bimonthly (January, March, May, July, September, November) by Woodsmith Corporation, 2200 Grand Ave., Des Moines, IA 50312. Printed in U.S.A.

ShopNotes is a trademark of Woodsmith Corporation. ©Copyright 1992 by Woodsmith Corporation. All rights reserved.

**Subscriptions:** Single Copy, \$4.95. One year subscription (6 issues), \$19.95. Two years (12 issues), \$35.95. Canada/Foreign, add \$4.00 per year.

**Second Class Postage Pending** at Des Moines, IA and at additional offices.

**Postmaster:** Send change of address to ShopNotes, Box 11204, Des Moines, IA 50340-1204

**Subscription Questions?** Call 1-800-333-5854, 8am to 5pm, Central Time, weekdays.

## EDITOR'S NOTE

**T**here's an interesting dilemma about having a well-equipped shop. If you had everything you always wanted for your shop . . . where would you put it all?

Shop storage always seems to be at the top of every woodworker's wish list.

It's no different in our shop. All too frequently I hear the cry, where are the No. 8 screws? Screws, like a million other supplies are usually in the small box they came in, and that's missing.

Okay, I know you can get plastic bins or one of those cases with dozens of small plastic drawers. We even have some in our shop.

But deep down, I've always wanted to replace them with some nice wooden boxes. More than that, I wanted a shop storage *system*.

Ideally, this system would solve three nagging problems.

First, the boxes would be quick and easy to build. (Nobody likes to spend a lot of time building storage boxes.)

Second, I wanted boxes that were transportable. That is, I wanted to carry individual boxes to wherever I was working.

Third, I wanted an easy way to get a label on the box that was big enough so I could read it, and easy to change whenever I needed to.

Jan Svec (our project designer) came up with exactly the design I was looking for (page 16). It sure has helped organize our shop.

**NEW IDEAS.** One of the advantages of working with a whole staff of woodworkers is the

wealth of ideas and different approaches to everyday problems.

For example, I've always liked working with cabinet scrapers. (It's a small piece of thin steel used to scrape a surface smooth, rather than using sandpaper.)

I used a very traditional method for forming the edge with a mill file first, then honing with a stone, and finally rolling the edge with a burnisher.

One day I was grumbling about this long process, especially the second step (honing with a stone). So I decided to skip that step. It worked great.

As I was talking about my new-found method, Ken Munkel (our design director) told me about the method he uses that involves reshaping the edge of scraper to make it even faster to sharpen.

Now one of my favorite tools is even easier to use.

**NEW FEATURE.** In this issue, we're introducing a new feature, the Hardware Store. The idea is to present information on individual pieces of hardware, particularly how to install them. This first time out, the Soss Invisible hinge gets the attention.

**100,000 SUBSCRIBERS.** One last note. When we introduced *ShopNotes*, we had no idea how it would be received.

Well, the response has been phenomenal. We already have over 100,000 new subscribers in the first two months.

I want to thank you for giving us a try. And a special thanks to those who wrote to us with your comments, praise, concerns, and well-wishes.

I hope you enjoy this issue.

# Contents

## Drill Press Caddy \_\_\_\_\_ 4

*This handy Drill Press Caddy provides instant access to your bits and accessories.*

## Radial Arm Saw Fence \_\_\_\_\_ 7

*A versatile Radial Arm Saw Fence along with two shop-made fence accessories: a stop block and a hold-down.*

## Combustibles \_\_\_\_\_ 10

*How to prevent spontaneous combustion from occurring in your shop. Also, tips on safe disposal of finishing supplies and materials.*

## Hand Scrapers \_\_\_\_\_ 12

*Two methods for sharpening a scraper let you create a cutting burr in just a few minutes. (We've also included a burnishing jig to make it even faster.)*

## Storage System \_\_\_\_\_ 16

*This wall-mounted storage system features a variety of shop-made bins. The different-sized bins allow you to customize the system to meet your storage needs.*

## Joiner's Mallet \_\_\_\_\_ 22

*Laminated construction is combined with lead weights to create a mallet with excellent balance and heft.*

## Hand-Cut Mortises \_\_\_\_\_ 26

*The right tools coupled with a simple technique will have you cutting mortises by hand in no time.*

## Shop Solutions \_\_\_\_\_ 28

*Five shop-tested tips: A Countersink and Bit Organizer, Framing Square Stop, Finishing Stand-Offs, Radial Arm Saw Depth Stop, And an Idea for Gluing-Up.*

## Soss Hinges \_\_\_\_\_ 30

*A brief history, applications, and tips on installation.*

## Sources \_\_\_\_\_ 31

*Hardware, project supplies, and mail order sources for the projects in this issue.*

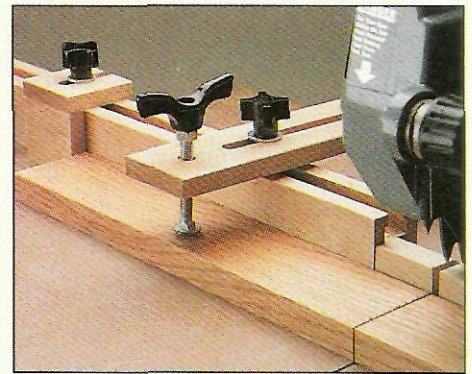

Radial Arm Saw Fence page 7

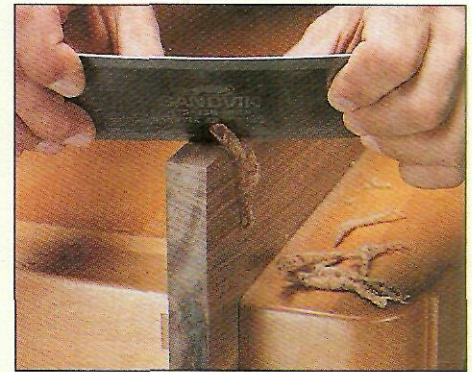

Hand Scrapers page 12

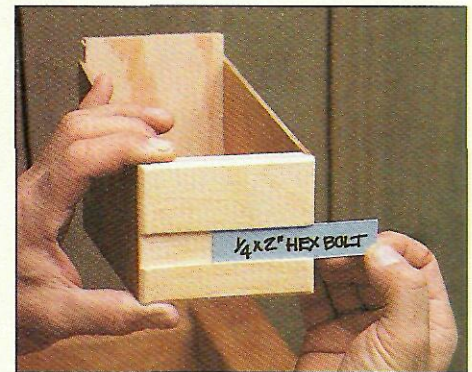

Storage System page 16



Joiner's Mallet page 22

# Drill Press Caddy

*The trays of this storage caddy swivel out and provide instant access to your drill bits and other accessories.*

Storing drill bits is always a problem. Putting them in a drawer or cabinet keeps them clean and organized. But they're not handy, especially if you're using a floor-model drill press. A tray mounted to the drill press is convenient, but you run the risk of sweeping away the smaller drill bits along with the shavings.

To solve this problem, I combined the benefits of the enclosed drawer with the convenience of a column-mounted tray — the result is the shop-made Drill Press Caddy shown in the photo.

The design is very simple, it's just a pair of trays sandwiched between a top and a base. Using a carriage bolt as a pivot, the trays swing open to provide access to bits and accessories.

## THE TRAYS

To build the caddy, start by making the two trays. The upper tray is shallow and holds a variety of bits. The bottom tray is deeper and is sized to hold a

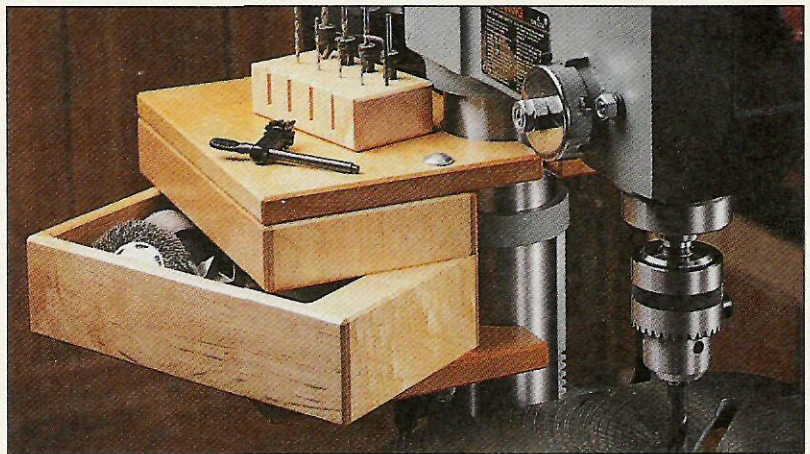

variety of accessories, see photo.

The only unusual thing is the front of each tray is made from 1½"-thick stock. This provides extra strength for the carriage bolt that passes through the fronts of the trays as a pivot pin.

**FRONTS.** The first step is to make the 1½"-thick fronts (A). The length of both fronts is the same (5½"), the only difference is the width (height) of these pieces, see Fig. 1.

**BACKS/SIDES.** With the fronts

cut to size, the next step is to make the backs and sides. To keep the trays as light as possible, I cut the backs (B) and sides (C) from ½"-thick stock, see Fig. 1.

**RABBETS.** Next, the ends of the sides (C) are rabbeted to accept the fronts and backs. All the rabbets are ¼"-deep, but since the front and back are different thicknesses, the widths of the rabbets are also different, see Figs. 2 and 3.

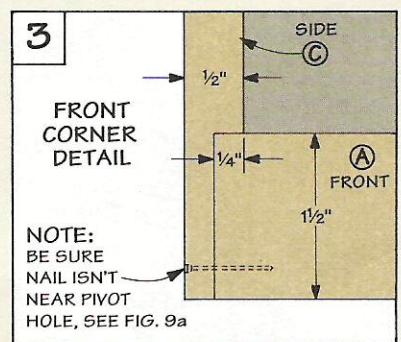
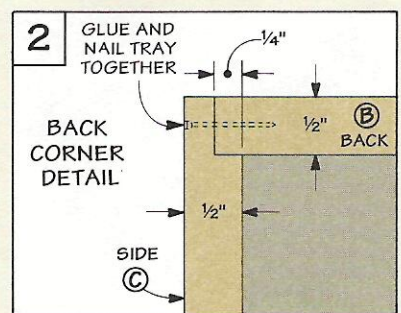
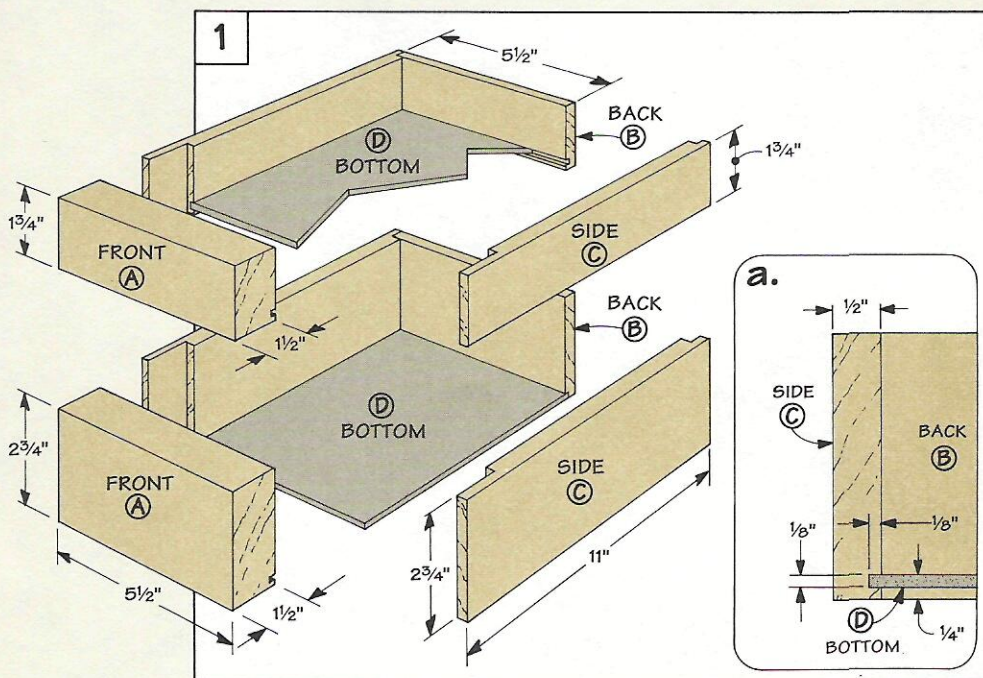

**GROOVE.** With the rabbets complete, cut a 1/8"-deep groove on the *inside* face of the fronts, backs, and sides to hold the 1/8" Masonite bottoms, see Fig. 1a.

To determine the size of the bottom, dry clamp a tray together. Then measure the inside length and width and add 1/4" to each dimension. Next, cut two *bottoms* (D) to size and glue up the trays, see Fig. 1.

**TOP COVER & BASE**

After you've glued up the trays, work can begin on the *top cover* (E) and *base* (F). Start by edge-gluing enough 3/4"-thick stock to form two blanks, see Fig. 4.

The length of the top cover and base is the same as the length of the trays (11"). But to allow the caddy to fit around the drill press column, the top cover and base are cut 4 1/2" wider than the trays (10 1/2"), see Fig. 4.

**NOTCHES.** A section of the top cover becomes the clamp used to hold the caddy to the drill press column. To make this clamp, first lay out a circle on both blanks. Then rip the top cover and base through the center of the circle (to a width of 8"), see Fig. 4.

Now cut out the half-circle notches with a sabre saw. Then trim the cut-off section of the top cover to form the *clamp piece* (G), see Fig. 5.

**MOUNTING HOLES**

The only thing left is to drill the holes for attaching the clamp to the top cover with lag screws. To make sure that these holes are aligned, lay out the hole locations on both the top cover and clamp at the same time, see Fig. 6.

I used an auxiliary fence on the drill press table to support the workpiece, see Fig. 7. With the fence in place, drill two 1/4" shank holes through the clamp. Then, drill two 3/16" pilot holes in the top cover, see Fig. 8.

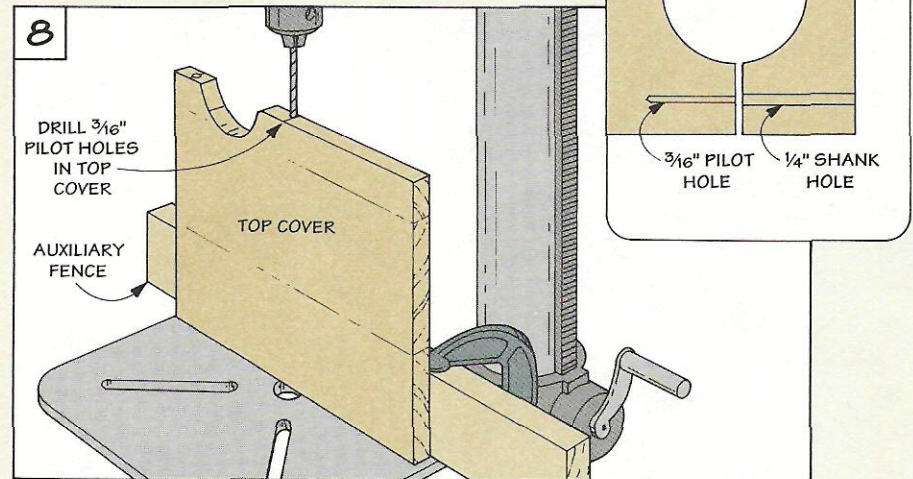
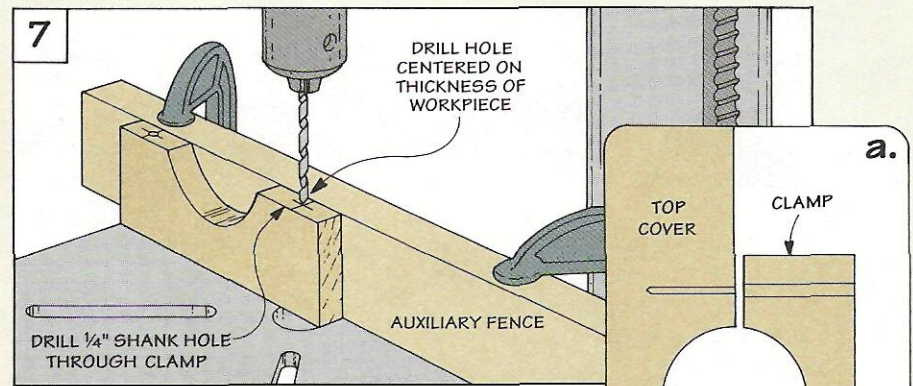
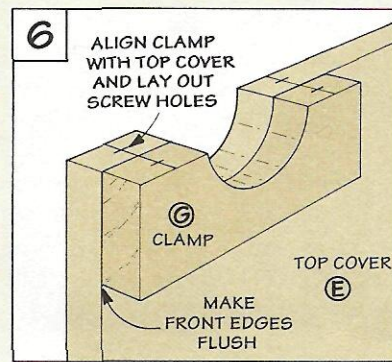
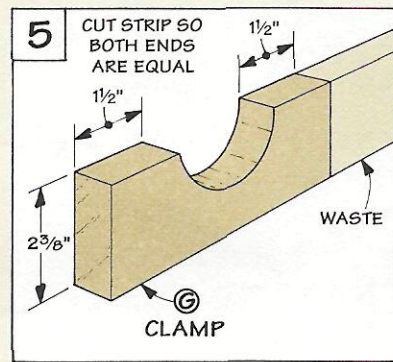
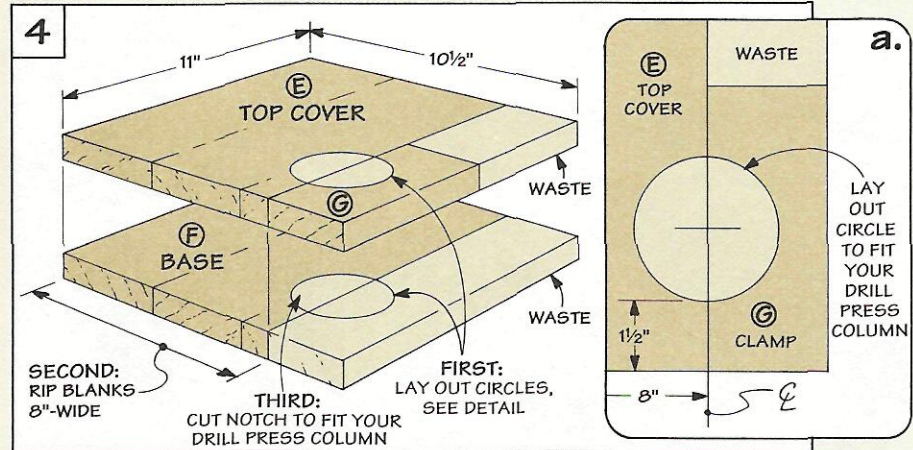

# Assembly

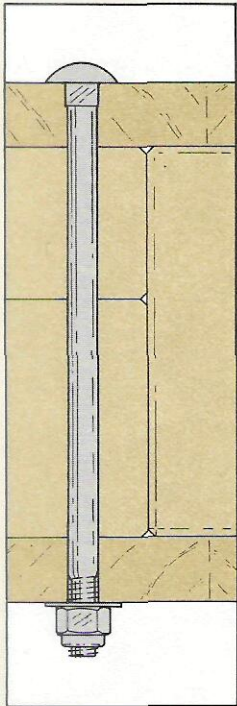

*A carriage bolt passes through the caddy. And a lock nut keeps the bolt tight while allowing the trays to pivot.*

The top cover, trays, and base are joined with a long carriage bolt that serves as a pivot pin for the trays to swing out.

**PIVOT HOLES.** To make sure all the holes for the carriage bolt align in all the pieces, I used a simple positioning jig. It's just a pair of cleats clamped to the drill press table, see Figs. 9 and 10.

To position the cleats, first mark the location of the hole on one of the trays, see Fig. 9a. Then position a drill bit directly over the mark and clamp the cleats along the front and side of the tray, see Fig. 9.

Next, drill a hole in both trays. Then without moving the cleats, drill a hole through the top cover and base, see Fig. 10.

**STOP BLOCK.** To keep the trays aligned when they're closed and to tie the top cover and base together, I added a stop block (H).

This block is cut from 1½"-thick stock, and its length is the same as the combined height of the trays (4½"). To determine the width of the block, subtract the width of the trays from the width of the top cover (2"), see Fig. 11.

**CHAMFER EDGES.** Before assembly, I routed an 1/8" chamfer on all the parts. Then I wiped on two coats of tung oil finish.

**ASSEMBLY.** Once the finish is dry, bolt the top cover, trays, and base together with a 3/8" carriage bolt and a lock nut, see Fig. 11. Then position the stop (H) and screw it in place, see Fig. 11.

**MOUNTING THE CADDY.** All that's left is to mount the caddy to your drill press column by attaching the clamp (G) to the top cover (E) with a pair of 4"-long lag screws, see Fig. 12.

Note: If your drill press has a "toothed rack" for raising and lowering the table, mount the clamp above the retaining ring, see Fig. 12.

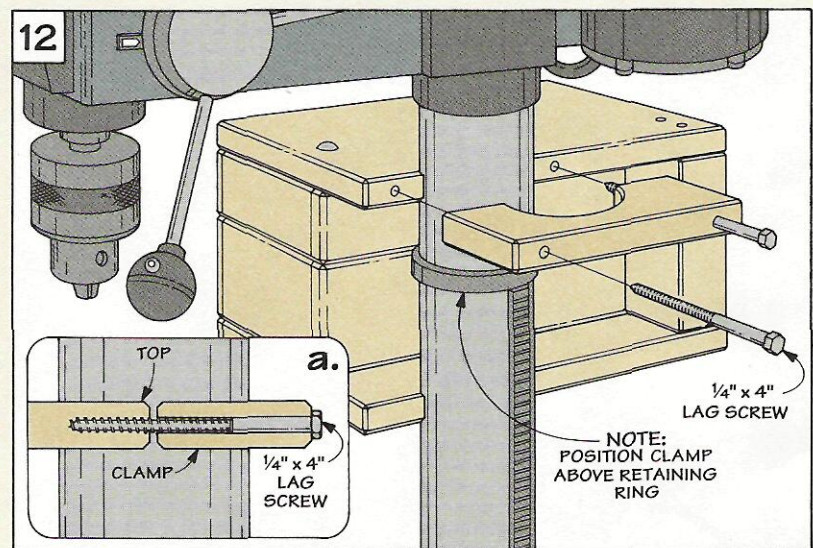
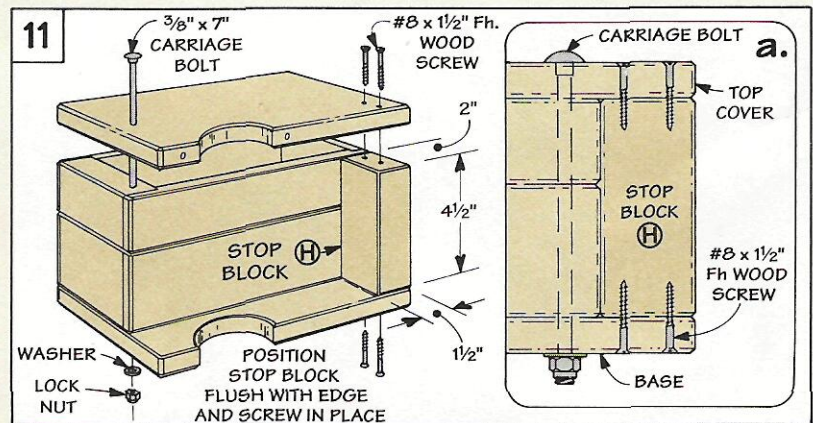
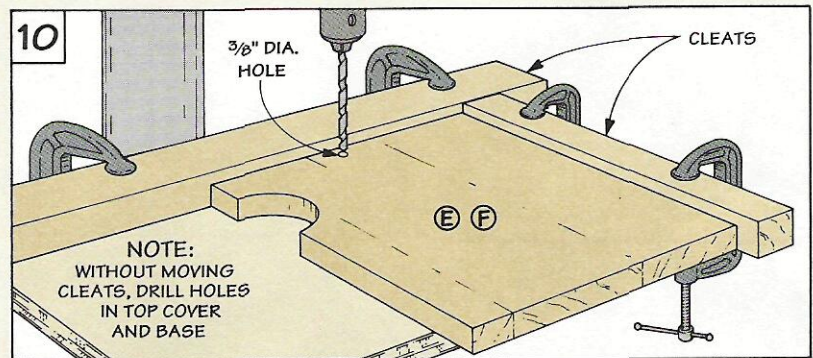
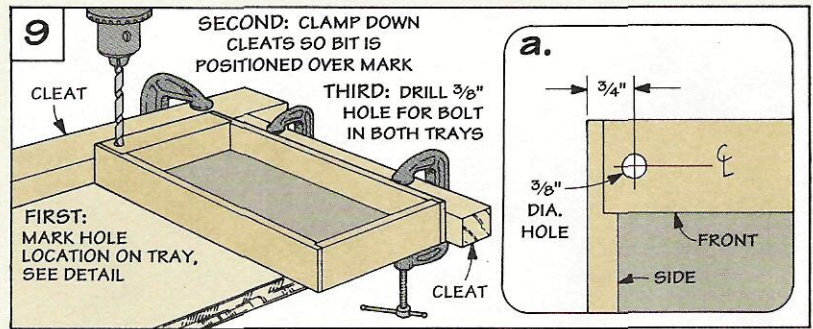

# Radial Arm Saw Fence

This radial arm saw fence has a couple of features that set it apart from standard fences.

First of all, a T-slot is cut in the top edge of the fence for attaching a hold-down and stop block. (For more on these accessories, refer to page 9. Sources for the hardware are listed on page 31.)

This fence is also designed with a replaceable insert where the saw blade cuts through the fence, see Fig. 1. When the insert gets cut up, it can be replaced without making a whole new fence.

**BLANKS.** The fence starts out as two 40" long blanks, see Fig. 1. Each blank is made of two pieces of 3/4"-thick stock glued together. (I used maple.)

To determine the width (height) of the blanks for the fence, first measure the thickness of your table (1" in my case), and then add 2", see Fig. 1. Now rip the pieces to this width and cut them 40" long.

**CUT T-SLOT.** After you've cut the four pieces to size, the next step is to cut the T-slot. This is a two-step process.

Start by cutting a 3/8" x 3/8" groove in the face of each piece, see Fig. 2. Then turn each piece

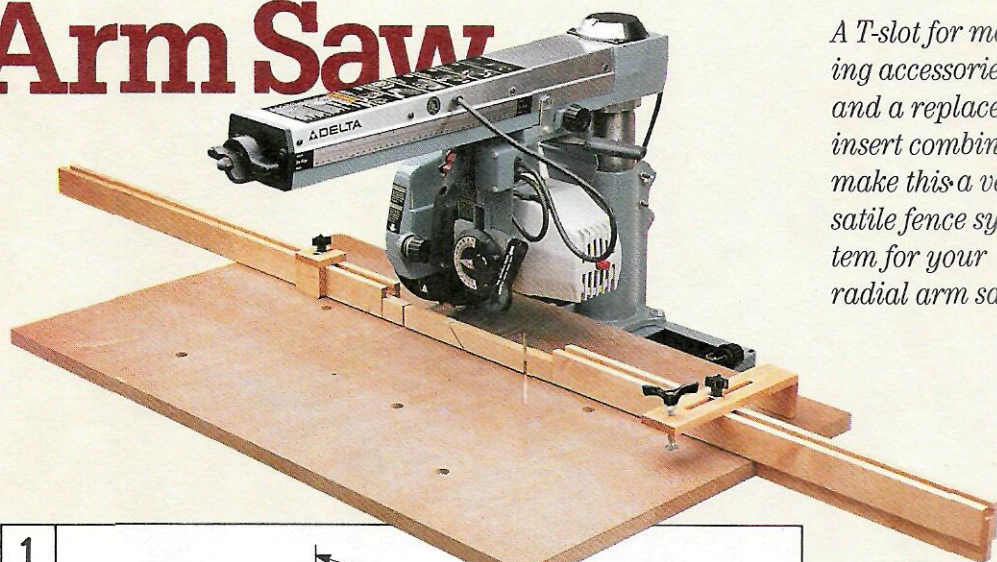

*A T-slot for mounting accessories and a replaceable insert combine to make this a versatile fence system for your radial arm saw.*

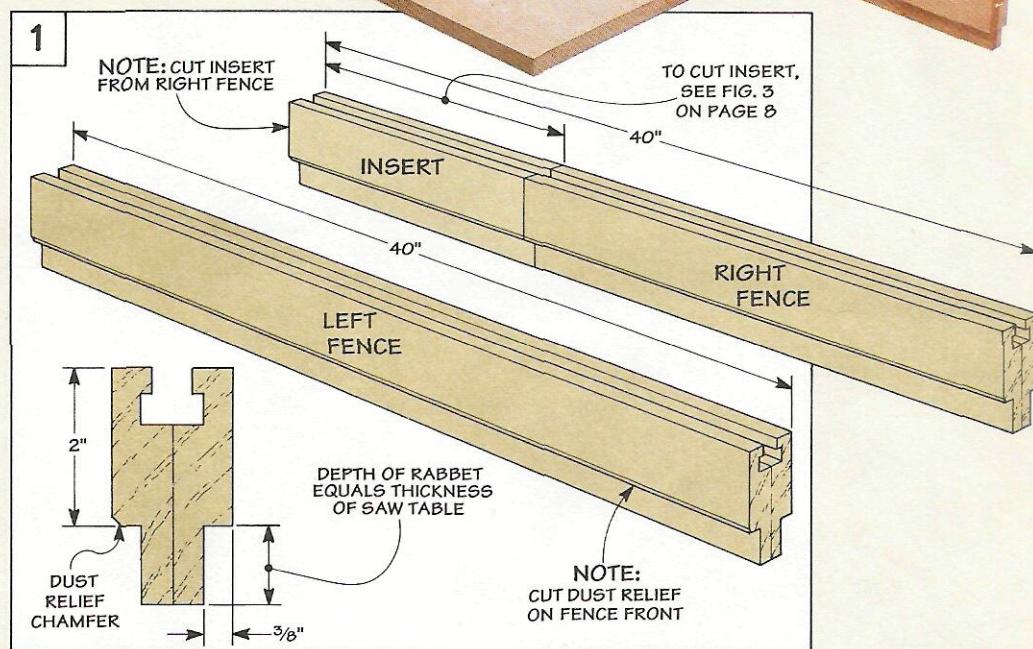

on edge, and trim 1/4" off the "tongue" formed by the groove.

**GLUE-UP.** Now you can glue and clamp together the two halves to form the two blanks. (To

keep the T-slots aligned, see tip at right.)

**FORM TONGUE.** When the glue is dry, the next step is to form the tongue that fits into the radial arm saw table. To do this, cut a rabbet on both sides of each blank, see Fig. 2.

I cut the rabbets to leave a 3/4"-thick tongue, the same thickness as the original fence. And I sized the height of the tongue to equal the 1" thickness of my saw table, see Fig. 1.

**DUST RELIEF.** To provide a relief for sawdust, I chamfered the front bottom edge of the two blanks, see Fig. 2.

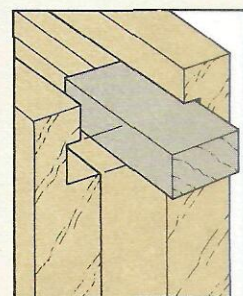

*A waxed wood "key" helps keep the T-slot aligned during glue-up.*

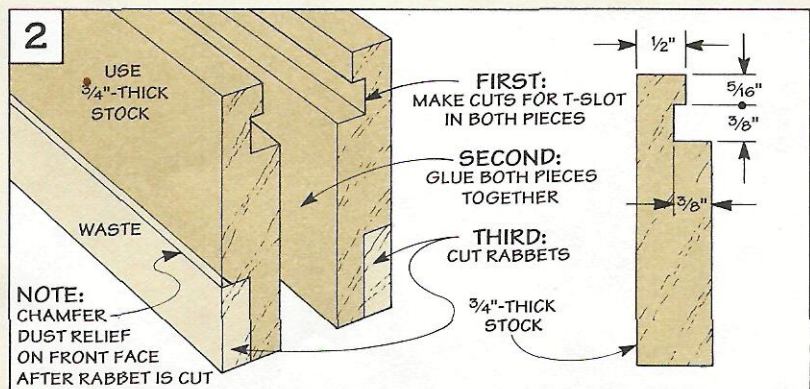

After completing the fences, work can begin on the insert. The insert is trimmed off the *right* fence, refer to Fig. 1 on page 7.

The length of the insert is sized so the blade will pass through the insert instead of the fence when making 45° and 90° miter cuts, see Fig. 3.

**SIZE INSERT.** To determine this length, set the blade for a 90° cut, and raise the blade above the fence. Then position the end of the right fence 2" to the *left* of the blade, and mark the path of the blade on the fence, see Fig. 3.

Next, pivot the blade to 45°, and then mark this path. Now measure 2" to the right of the end of the blade's 45° line of travel, and cut the insert to this length. (I added 2" on both ends to support the sides of the kerf.)

**TRIM INSERT.** To allow clearance behind the fence for the blade, you need to trim the insert. At 90°, the blade on my saw almost touches the top back edge of the insert. To keep from accidentally cutting the insert, I trimmed off the T-slot, see Fig. 4a.

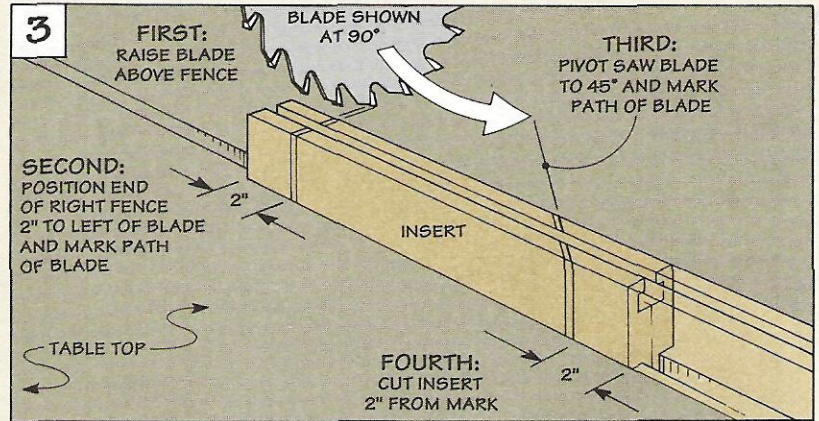

Then, to allow the blade to pivot to 45° without scraping the back of the insert, I cut a chamfer on the top back edge, see Fig. 4a.

**INSTALL FENCE.** The last step is to install the fence. To do this, remove the back table and spacer board, see Fig. 5. Then position the left end of the insert 2" to the left of blade. Next, butt the ends of the fences against the insert.

To secure the fence, I drilled countersunk shank holes in the "tongues" of the right and left fences and screwed them to the front table. Note: To make replacement easier, don't screw the

insert to the front table.

Now replace the spacer board and rear table, and tighten the table clamps, see Fig. 5a. Finally, cut a kerf in the insert for 90° cuts, 45° miters, and 45° bevels. To do this, lower the blade so it scores the table, and make cuts.

**OPTIONAL INSERTS.** Depending on the type of cuts you make with your saw, you may want to keep a "library" of inserts. I use a separate insert for cutting dadoes and odd-angled miters. And to ensure smooth ripping, I save one insert that doesn't have any kerfs cut in it at all.

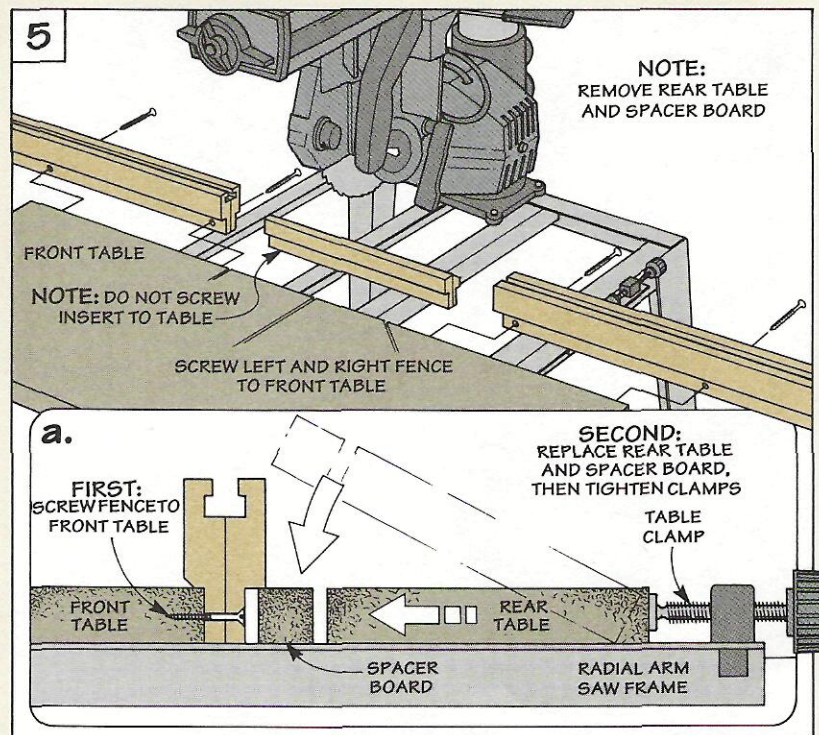
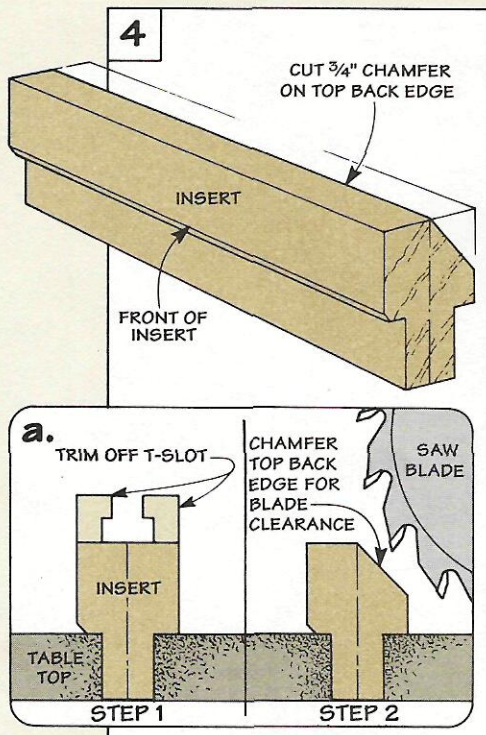



# Fence Accessories

## Hold-Down

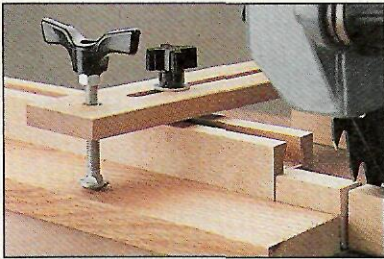

■ To secure pieces when cutting, I made a hold-down that attaches to the T-slot in the fence, see photo above.

When cutting short pieces, the hold-down is a real finger-saver. And when cutting long boards, it keeps the waste end from lifting off the table.

The hold-down consists of two pieces: a *support block* and an *adjusting arm*, see drawing.

To make the hold-down, first cut the arm and support block to size from 1/2"-thick hardwood, see drawing. Then drill a hole in the arm for a threaded insert.

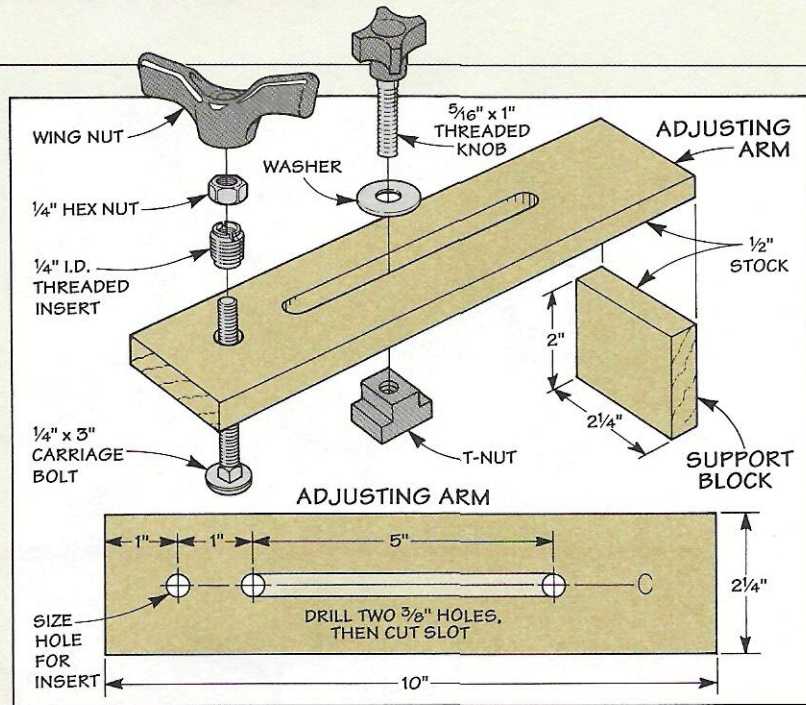

The insert holds a carriage bolt with a wing nut on the end to tighten the head of the bolt down on the workpiece, see photo.

To make the hold-down adjustable for different widths, I

cut a slot in the arm.

Finally, add a support block to keep the hold-down from rocking when tightened. Glue the support block to the arm. Then attach the hardware, see Sources, page 31.

## Stop Block

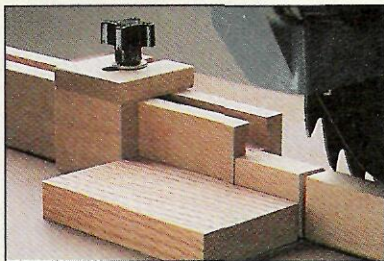

■ For crosscutting boards to identical lengths, a stop block is very handy. Just like the hold-down, the stop block locks into the T-slot of the fence by tightening a threaded knob into a T-nut, see photo above.

The stop block is pretty basic. It's just two pieces of hardwood glued together in an L-shape, see drawing. The vertical piece is the

"stop" that positions a board on the table.

I cut both of these pieces from 1/2"-thick hardwood to a width of 2 1/4". When cutting the stop (vertical) piece to length, I cut it slightly less than the height of the fence to keep it from rubbing on the table top.

The top piece has a 3/8"-wide open-ended slot to accept the shank of the threaded knob.

To prevent sawdust from building up between the end of a workpiece and the stop, I cut a small chamfer on the bottom corners of the stop, see drawing.

**GLUE-UP.** Finally, glue the two pieces together, and attach the stop block to the fence.

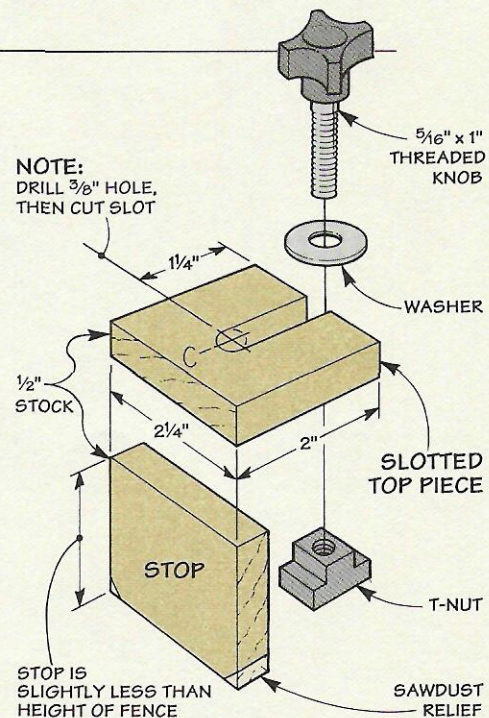

# Combustibles



*Fire in the shop is something most woodworkers don't want to think about. But proper use and disposal of combustibles can reduce the risk.*

**L**ike a lot of woodworkers, we have at least a dozen different cans of finishes and solvents on a shelf in our shop.

And like almost everyone, we've read the warnings over and over about how combustible and flammable some of the products are. Still, I never really believed a fire could happen in *our* shop. I was wrong.

One weekend, one of the guys had just finished wiping a last coat of tung oil on a desk he was making. Just before closing up the shop for the night, he tossed a few of the rags he'd been using into a plastic trash can.

The next morning, the shop was filled with black smoke. All that remained of the trash can was a few charred fragments. Fortunately, the fire had burned itself out on the concrete floor before spreading to the rest of the shop.

## SAFETY DEVICES

It's a little like closing the barn door after the cow's gone, but we started installing safety devices

the morning after the fire.

**METAL WASTE CAN.** First of all, we bought an airtight, self-closing, metal waste can (the kind you see in gas stations and machine shops).

**FIRE EXTINGUISHER.** Then we hung a fire extinguisher by the shop door. We bought a ten pound "ABC" type extinguisher that's charged with a dry chemical for use on either wood, flammable liquid, or electrical fires.

**SMOKE ALARM.** Finally, we picked up a smoke alarm from the hardware store and mounted it on the ceiling of the shop.

But even after we had installed these safety devices, I still felt a little uneasy. What about another fire like the one we'd had — one that breaks out when there's no one in the shop? For this kind of fire, all our safety devices were like a band-aid on a broken arm.

The only way to *prevent* another fire was to find a safe way to get rid of the used finishing supplies that piled up around the shop. I decided to do it right and called our local fire marshal.

## SPONTANEOUS COMBUSTION

He said the fire in our shop was caused by spontaneous combustion — one of the leading causes of workshop fires.

**HEAT SOURCE.** So how does a fire start in a pile of used finishing supplies? When the solids in oil finishes combine with the oxygen in the air, they form a polymer — a plastic-like substance.

This reaction does two things. First, it creates a hard, lasting finish on the project you're working on. Second, it gives off heat.

**SOLVENTS EVAPORATE.** At the same time as this chemical reaction is occurring, the solvents in the finish are evaporating. If enough heat builds up from the reaction *before* the solvents have evaporated, the solvents can reach an ignition temperature and spontaneous combustion occurs. (For some solvents this temperature is as low as 250°.)

## FIRE TRIANGLE

The key to preventing spontaneous combustion is to remove

one of the three parts of the fire triangle: fuel, oxygen, or heat. The obvious question that arises is which one?

**FUEL.** Unless you use water-based finishes, you'll have the potential of spontaneous combustion with any finish that has natural oils as one of its ingredients (linseed oil, tung oil, gels, and wipe-on finishes).

The problem extends to rags, brushes, steel wool, and other supplies used to finish the project.

What about finishing supplies that have been soaked with finishes such as shellacs or lacquers? There's *no* danger of spontaneous combustion, because the solids in these finishes don't react with the oxygen in the air. As a result, no heat is generated.

But there is a chance that the vapors from the solvents can cause a flash fire while you're applying these finishes. This explains the warnings to extinguish pilot lights or open flames when using these products.

**OXYGEN.** Removing the oxygen seems like the next best bet. Several companies manufacture self-sealing, heavy-gauge metal waste cans that are designed to seal out the air from the shop.

Even if the rags ignite (there's still air inside the can), the fire snuffs itself out from lack of oxygen. At least that's the theory.

The problem is if the rags do ignite, the waste can may get hot enough to ignite other nearby combustibles, like wall paneling or the sawdust on your shop floor.

To prevent this from happening, a warning is stencilled on the can that reads, "empty every night." The question is where do you dump the contents so you don't just transfer the problem?

**HEAT.** Since eliminating the fuel or oxygen isn't always a workable solution, removing the

heat is the only other alternative.

The problem is that it's impossible to *remove* the heat. Why? Because once the finish has soaked into a rag or brush, the finish solids begin to react. This reaction generates heat. Always.

Doesn't the temperature increase cause the solvents to ignite? Not if the heat from the

---

*The best (and easiest) solution I've found is to spread out oil-soaked rags on a concrete floor.*

---

reaction can escape. The danger of spontaneous combustion arises when the heat is allowed to build up in a confined area.

### SOLUTIONS

To make a long story short, there are several ways to prevent the heat build-up from reaching an ignition temperature.

**WATER BATH.** One way is to limit the amount of heat build-up by soaking the used finish supplies in a water-bath.

This solves the problem, at least temporarily. With the rags immersed in the water, there's no heat build-up.

But once you remove the rags from the water, the moisture evaporates and the finish solids continue to react and generate heat. Plus, you've just created several gallons of contaminated water to get rid of.

**BURN RAGS.** In addition to the water bath, the label on linseed oil (one of the *most* reactive of finish products) suggests burning the rags. If local ordinances allow you to incinerate waste, this could be a workable answer.

**SPREAD OUT RAGS.** But the best (and easiest) solution I've found is to spread out the rags on a concrete floor, or hang them on a nail or clothesline. (Be sure they're away from kids and pets.)

This allows the combustible solvents in the rags to evaporate. At the same time, it permits the finish solids to react without the confinement that causes heat to build up.

**DISCARD RAGS.** When all the solvents have evaporated and the solids have finished reacting, the rags will be dry and stiff. At this point, they're not a fire hazard, and you can safely discard them along with the rest of the trash.

To see if this was a problem, I called the Iowa Department of Natural Resources.

They said waste that has been contaminated with petroleum-based solvents must pass the "paint filter test."

To pass this test, the waste must be solid enough so it doesn't drip through a filter that's about as heavy as a coffee filter.

Obviously, the dry, stiff rags pass the test. The solvents are the worst pollutants, and they will have already evaporated. At this point, discarding the rags is no different than throwing away a painted board.

### LIQUID WASTE

But what if you want to throw out something that won't pass the paint filter test, like a half can of used lacquer thinner?

Pouring the liquid on the ground can pipe the contaminants directly to your drinking water supply.

And if everyone flushed these solvents down the sewer, the water treatment plants would soon be overloaded.

**KITTY LITTER.** Instead, you can mix the liquid with an absorbent, non-combustible material like kitty litter and set it outside away from pets and kids. After the solvent has evaporated, package up the solid, and throw it away with the rest of the trash.

# Hand Scrapers

*Using and sharpening a scraper doesn't have to be a mystery. It's easy with the right technique.*

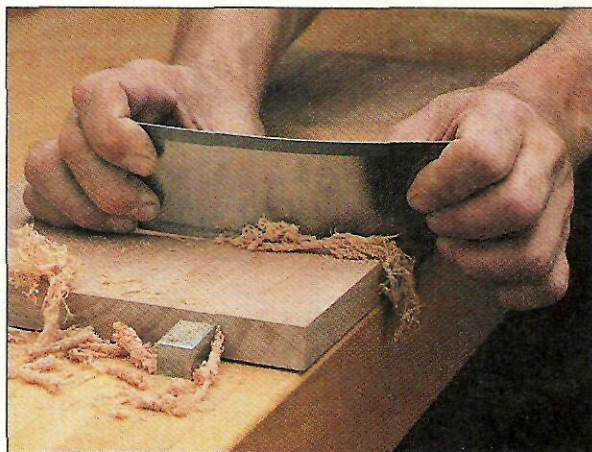

**A** hand scraper is the simplest of tools — it's just a thin piece of rectangular steel. However, when it's sharpened and used correctly it can produce amazing results. A scraper can quickly remove burns and planer marks on a workpiece (see photos below). It's also great for smoothing out figured grain and burls.

## THE BURR

How can a flat piece of steel be an effective cutting tool? The key is the "burr" you put on its edge. This burr resembles a small hook and runs along the length of the scraper, see drawing in the margin on the opposite page.

By holding a scraper at an angle and pushing or pulling it across a workpiece, this burr cuts a micro-thin shaving much like a hand plane. (For tips on using a scraper, see page 15.)

## SHARPENING

For years I used the traditional method to sharpen a scraper to create the cutting burr. This involves three steps. First, file the edge of the scraper square to both sides. Then the edge is honed smooth with an oil or water stone. Finally, a burnisher is used to form the burr. (A burnisher is a hardened steel rod that's fitted into a handle, refer to Fig. 3.)

**NO STONE.** After wearing a groove in my stone and cleaning up messy honing oil for years, I decided to skip the second step — I stopped honing the edge of the scraper with a stone.

Granted, using the stone to hone the edge creates a slightly sharper burr — but only for the first couple of strokes of the scraper. Then things even out. And not using a stone makes the

sharpening process *much* faster. (For instructions on this two-step method, see the next page.)

**BEVELED EDGE.** Just when I was feeling confident that I had found *the* way to sharpen a scraper, Ken Munkel (our design director) showed me another method he's been using for years.

With Ken's method, the edge of the scraper is beveled before it's burnished. This makes it easier to "roll" the edge and create the burr. And the angle of the burr lets you hold the scraper in a more vertical position (which some find more comfortable).

The problem with this method is the burr doesn't have as much steel to support it. Which means the burr tends to dull quicker. Also, this method limits you to one cutting edge on each side instead of two. (For more on Ken's sharpening method, see page 14.)

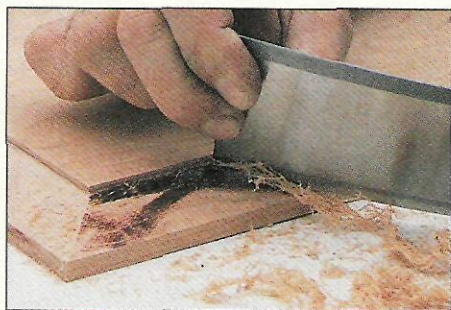

▲ **Burn Marks.** A hand scraper is the tool I reach for most often to remove stubborn burn and saw marks.

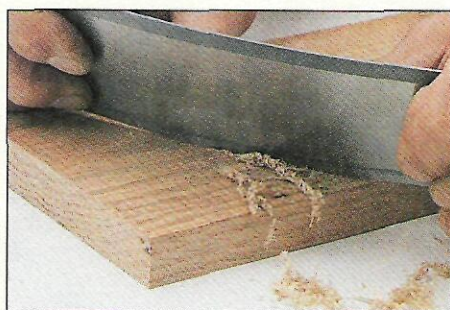

▲ **Planer Marks.** Hand scrapers can be used to quickly remove the ridges or marks left by a planer.



▲ **Highly-Figured Grain.** Smoothing highly-figured grain and burls is one area where a scraper has no equal.

# Two-Step Sharpening

My two-step method is used on a scraper with a square edge (not beveled). The two steps to producing a sharp burr are filing and burnishing. Filing ensures a clean, straight edge on the scraper, and burnishing creates the cutting burr.

## FILING

The first step is to file the edge square. To do this, I use a smooth mill file and clamp the file in a vise, see Fig. 1. (Note: If you're working with a metal vise, protect your file by clamping it between a pair of wood scraps.)

Then, hold the scraper 90° to the file and slide it the length of the file, see Fig. 1. Repeat this until you get a straight edge the entire length of the scraper.

**WIRE EDGE.** After you've filed the edge straight, the next step is to remove the rough wire edge, see Fig. 1a. This is easy to do — just lay the scraper flat on the edge of your workbench, see Fig. 2. Then, place the file flat over the edge of the scraper and rub it back and forth.

## BURNISHING

With the wire edge removed, the scraper can be burnished. Burnishing the edge of a scraper compresses the steel along the edge causing it to "flare out" slightly, see Step 1 in Fig. 3. This flare is

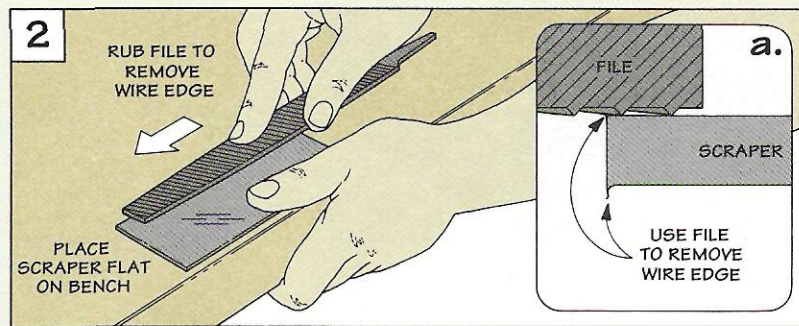
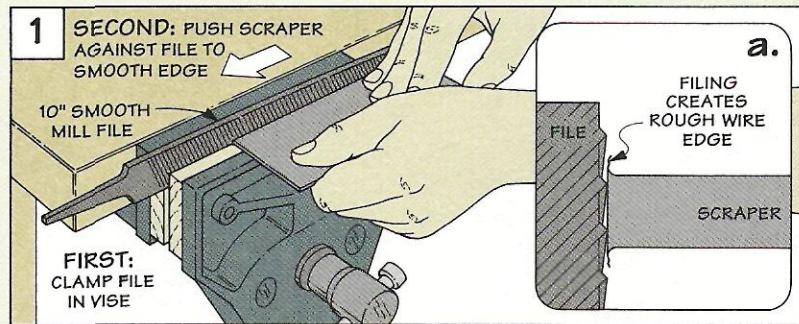

then bent over to form the cutting burr. I do this with a burnisher, see Steps 2 and 3. (See page 31 for mail-order sources for burnishers and scrapers.)

To burnish the scraper, start by clamping the scraper in a vise. Then, hold the burnisher square to the sides of the scraper and bear down. Now take a couple of strokes along the edge to compress the steel. Note: This takes considerable pressure. To make it easier, I use an auxiliary handle, see box below. Or use the jig shown on page 14.

**ROLL THE BURR.** Once the edge is compressed (Step 1), the next step is to roll the burr. To do this, hold the burnisher at a slight angle and bear down as you slide the burnisher along the edge, see Step 2 in Fig. 3. Then increase the angle a little and take another stroke, see Step 3 in Fig. 3.

**FEEL THE BURR.** The burr is small, almost too small to see. So after a few strokes, feel along the edge to see if the burr is uniform. If it's not, take another stroke. With one edge rolled, you can now sharpen the other edges.

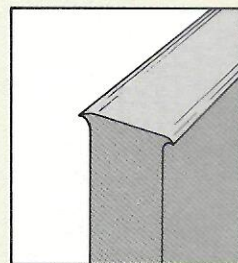

*The rolled burr on a square edge scraper provides the cutting action. One advantage to this method is you can roll a burr on both edges.*

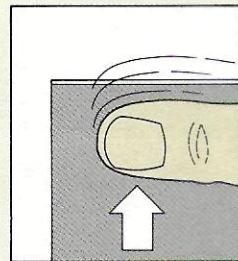

*To feel for the burr, move your thumb perpendicular to the edge.*

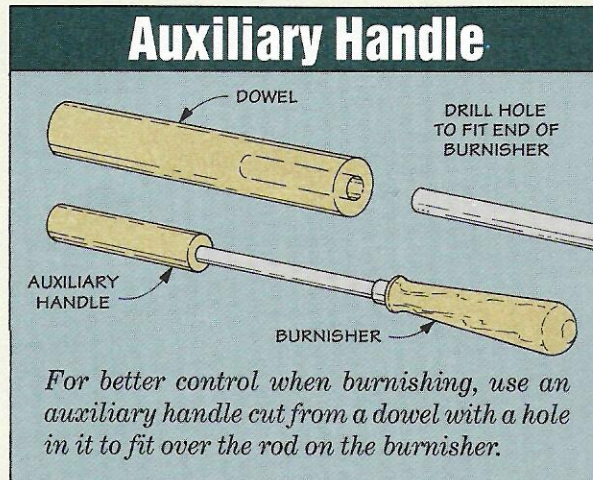
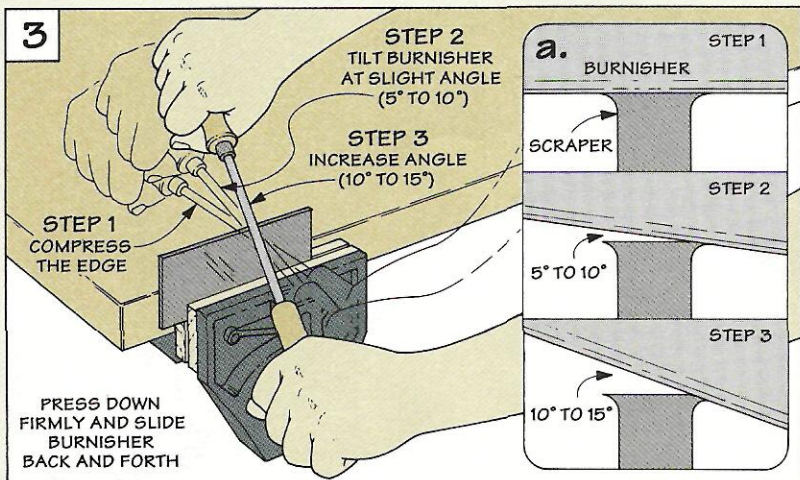

*For better control when burnishing, use an auxiliary handle cut from a dowel with a hole in it to fit over the rod on the burnisher.*

# Bevel Edge

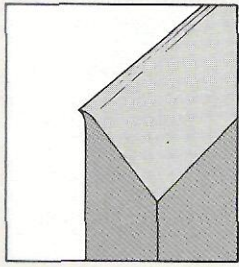

*A burr is easier to roll on a beveled edge than on a square edge. The acute angle creates a burr that's sharp, but fragile.*

I have to admit that I was a bit skeptical when Ken first showed me his sharpening method. But then I watched him sharpen a scraper in just a few minutes. And when he used it to cut delicate shavings, I was impressed.

**BEVEL THE EDGE.** Ken starts by filing a bevel on the edge of the scraper. The trick is to hold the file at about 45° and use firm strokes to create the bevel, see Fig. 4. (Note: The angle isn't critical as long as it's consistent and you file the edge to a point.) After the bevel is filed, flip the scraper over and remove the wire edge.

**BURNISH THE EDGE.** To remove the marks from filing, take a few light strokes with the burnisher held at the same angle as the bevel, see Step 1 in Fig. 5.

Then roll the burr with the burnisher held at about 15° to the bevel, see Step 2 in Fig. 5. Note: Since it's very easy to roll a burr on a beveled edge, check the burr after making a single stroke.

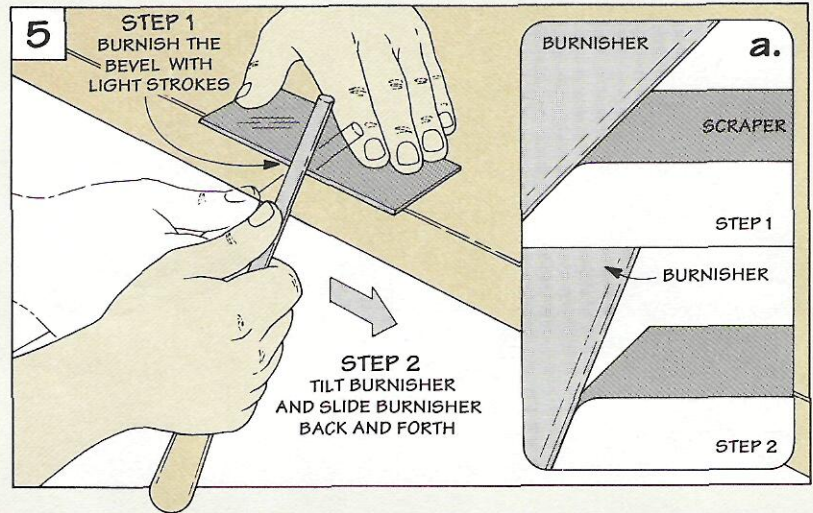
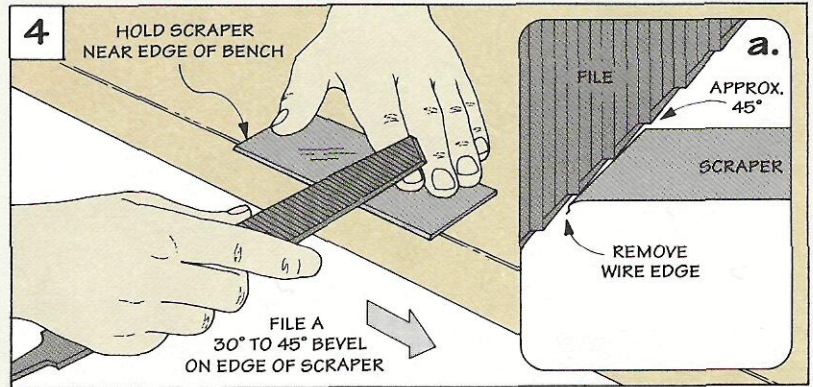

## Burnishing Jig

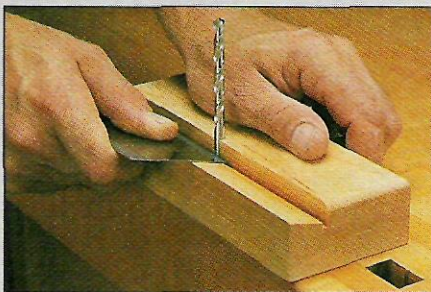

The hardest part of creating a burr on the edge of a scraper is holding the burnisher at a consistent and correct angle. One solution is a simple jig made from a piece of scrap wood and a drill bit, see photo.

To make the jig, start by drilling a 1/4" hole in a piece of 1 1/2"-thick stock. (The hardened steel drill bit will also

serve as the burnisher.) Then cut an angled rabbet so the drill bit protrudes slightly.

To use the jig, simply run the edge of the scraper over the drill bit to produce a uniform burr. Note: This jig works equally well on either square edge or beveled edge scrapers, see Figs. 2a and 2b.

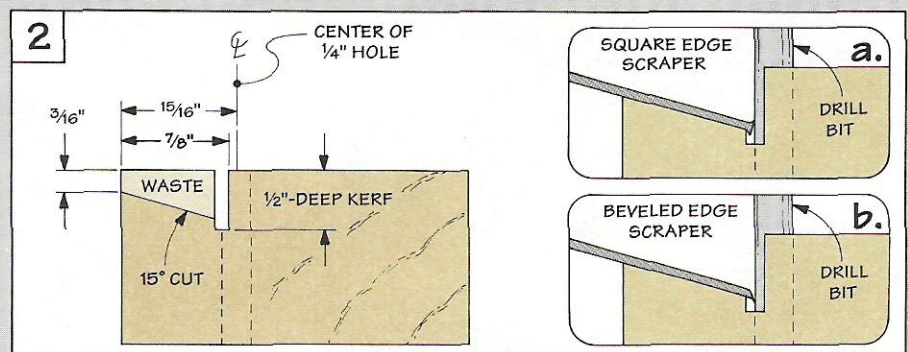
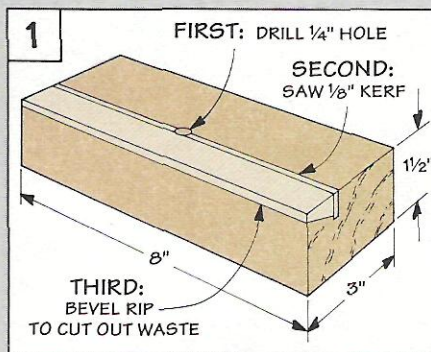

# Using a Scraper

No matter which method of sharpening you prefer, it also requires a little finesse to get a scraper to cut shavings rather than just scrape up sawdust. It's just a matter of flexing the scraper into a slight bow while pushing or pulling it across the workpiece, see Fig. 6.

The bow prevents the sharp corners of the scraper from digging into the workpiece, see Fig. 6a. And it also allows you to take a "feathered cut" — one that's *slightly* deeper in the center. This is particularly useful on wide boards where cuts overlap.

## PUSH OR PULL

Whether you push or pull is really a matter of personal preference. Pushing a scraper allows you to use your body weight which helps remove stock quickly. And some people find it easier to keep the scraper flexed to a uniform bow when they push a scraper.

But I've found that pulling a scraper offers more control of the cut. That's because you can pull the burr gradually into the surface of the workpiece. Granted, it doesn't remove the stock as quickly, but I'd rather take a shallow cut and be in control.

## FIND THE ANGLE

What matters the most is finding the angle where the scraper will produce delicate shavings instead of dust. And finding this angle is simply a matter of trial and error.

The angle that you use will depend on the burr on *your* scraper. Since the burrs are formed differently, a scraper with square edges is held lower to the workpiece than one with beveled edges, see Fig. 7.

Note: Whenever you resharpen a scraper, you'll need to find the new holding angle where it will produce shavings.

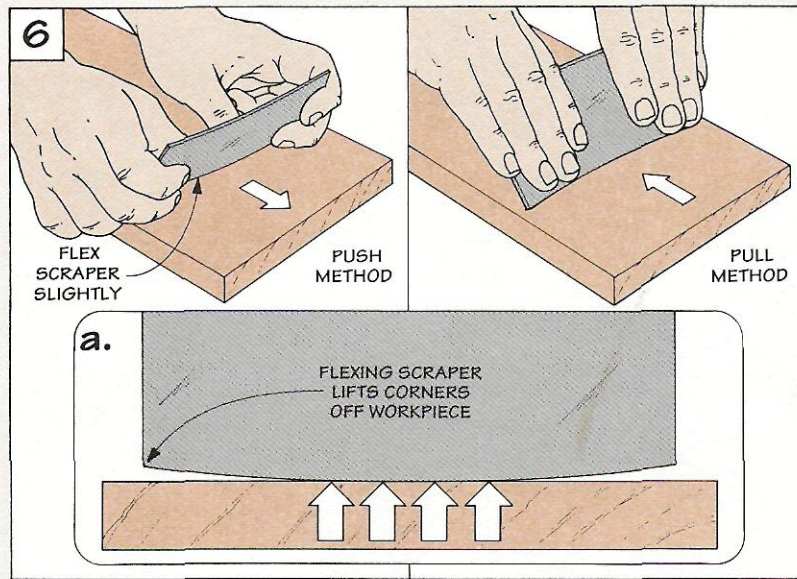

*Don't be misled by the name. A properly sharpened scraper cuts a shaving rather than scraping up sawdust.*

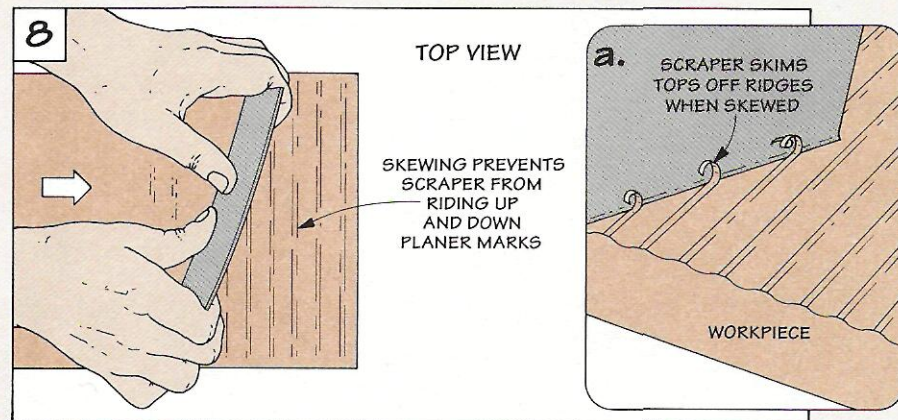
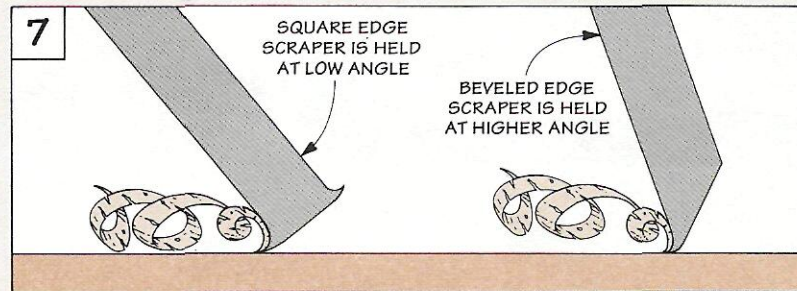

## SKEWING THE SCRAPER

One last trick that I use is to "skew" the scraper to the workpiece. This works especially well when removing planer marks, see Fig. 8.

If you hold the scraper parallel to the planer marks, it tends to ride up and down the marks like a roller coaster, leaving a surface

that's smooth but uneven.

Skewing the scraper cuts down the peaks and leaves a smooth, even surface. The skewed angle also creates less friction when you're scraping. Which means a cooler cut with less effort. And skewing a scraper helps prevent the burr from clogging up with shavings. The shavings curl and slide out the end of the scraper.

# Shop Storage System

*Inexpensive and easy to make, this wall-mounted storage system features removable bins so you can take them wherever you need them.*



**S**torage that moves — that’s the idea behind this storage system. Take a bin, hook it into strips mounted to the wall, or carry it right to your work-site. It couldn’t be easier.

But the first question I had was, how am I going to cut all those pieces? The secret to making the storage bins is to set up an “assembly line” to cut all of the same-size parts at one time. To keep the

total parts to a minimum for the basic system, I limited myself to two bin sizes.

**ACCESSORIES.** We designed this system so you can add accessories. We built a portable carrier to hold several storage bins. Then we added a tool bin to the carrier, see photo below. Another option is to convert the bins for specialized uses, like to hold rolls of masking tape. (See pages 20-21 for more.)

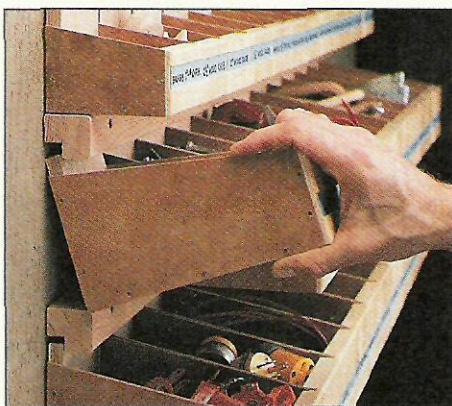

▲ The back of each bin “locks” into a wall-mounted rail. To remove the bin simply lift the front up and pull it out.

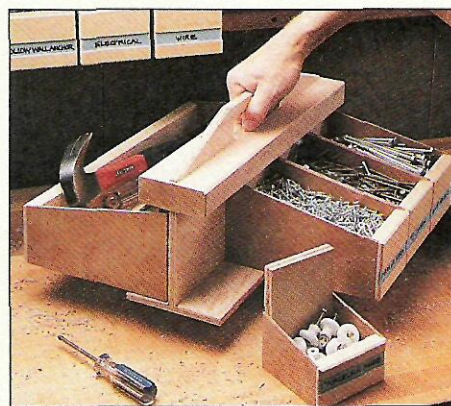

▲ Use this carrier to take bins and tools wherever they’re needed. When not in use it fits in the rails on the wall.

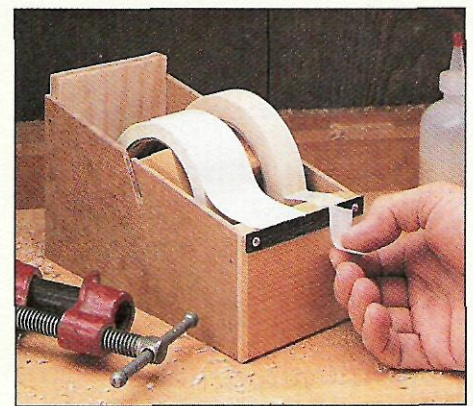

▲ This tape dispenser is another handy accessory. It’s just a storage bin with a few modifications.



# Bottoms, Backs, and Sides

Before making the bins, you have to determine how many bins of each size you want. For every large bin I wanted, it takes about a 16"-long strip of plywood, and for every small bin about a 9"-long strip, see Exploded View at right.

**PLYWOOD PIECES.** After cutting all the strips you need for the bins, each long strip is cut into a *back* (A), *bottom* (B), and the optional *dividers* (C), while each short strip is cut into a *back* (A) and *bottom* (D).

**SIDES.** I stacked up all of these plywood pieces, and then moved onto the *sides* (E, F). The sides are cut from blanks of 1/8"-thick Masonite, see Fig. 1.

First, cut enough blanks to size. Then the blanks are cut into two pieces to form the tapered sides.

The tricky part is cutting the sides exactly the same size while keeping your fingers away from the saw blade.

**STOP BLOCK.** To solve this problem, I made a combination

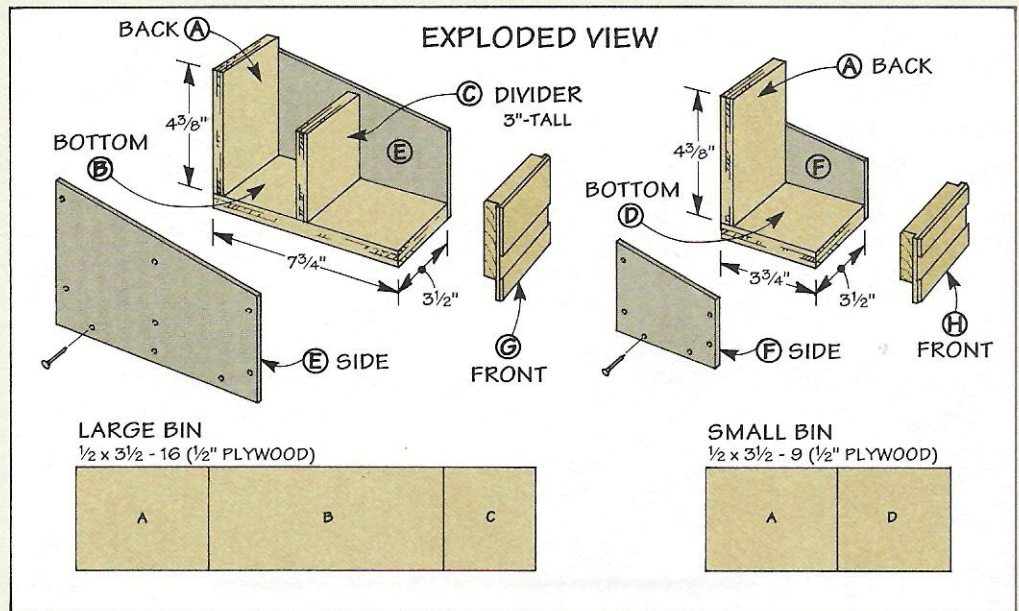

stop block and hold-down, see tip box at right. The stop block/hold-down is clamped to an auxiliary fence that's screwed to the miter gauge, see Fig. 2.

**CUT THE SIDES.** To cut the tapered sides, set the miter gauge to make a 10° cut. Then

position the stop to cut the correct width (3" for the large bins, 2" for the small bins) at the *short* end of the side piece, see Step 1 in Fig. 2. Cut one side piece off the blank, then rotate the blank and cut the mating side piece, see Step 2 in Fig. 2.

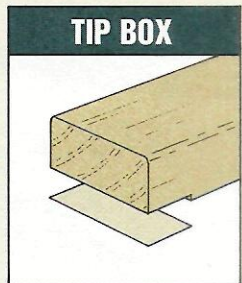

To make a combination stop block and hold-down, cut a shallow rabbet in a 2x4. For a better grip, glue on a strip of sandpaper.

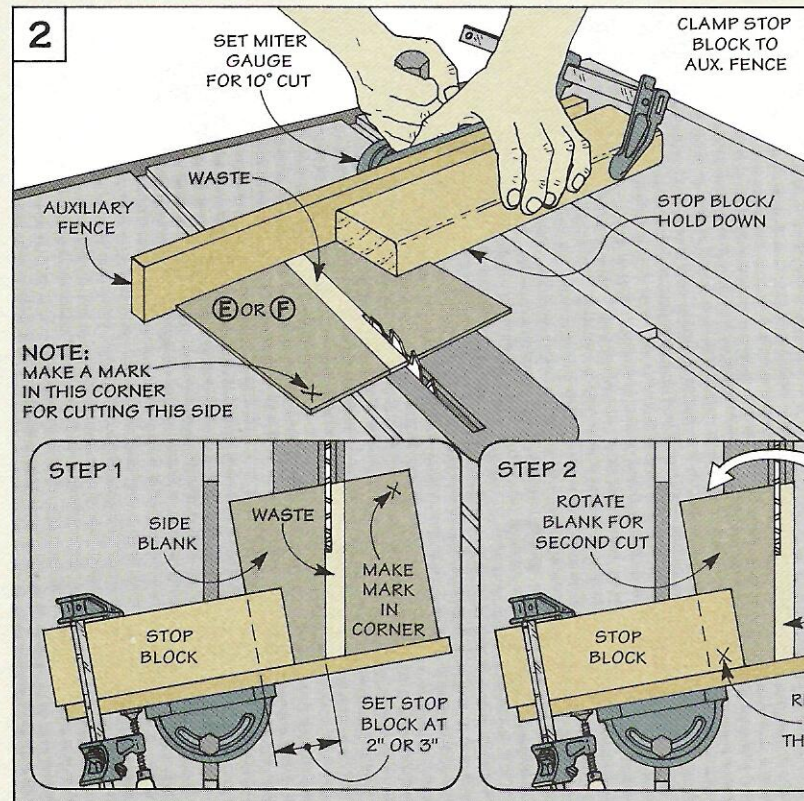
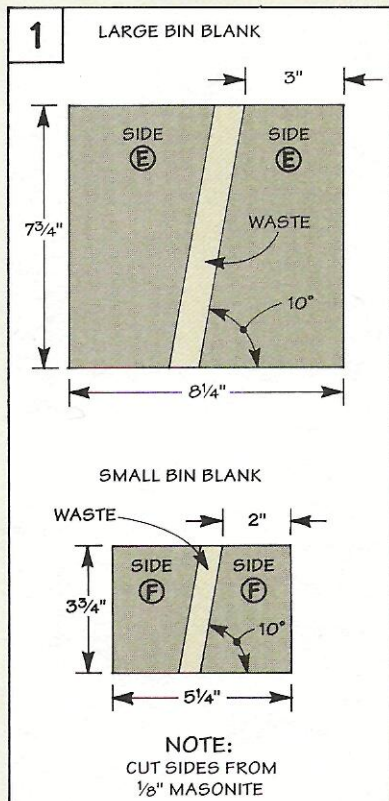

# Bin Fronts

*To help organize my storage bins, I cut a dovetailed slot in the front of each bin for a label.*

The only other piece needed for the bins is the *front* (G, H). (I used pine for the fronts, but any 3/4"-thick stock will do.)

**CUT STRIPS.** The fronts are cut from strips that are 2" wide for the small bins, or 3" wide for the large bins, see Fig. 3.

**DETERMINE LENGTH.** After the strips are ripped to the correct width, cut the fronts to finished length. To determine the length of the fronts, measure the width of a bin bottom (3 1/2"). Then add the combined thicknesses of both side pieces (1/4"). (In my case, the fronts are 3 3/4" long.)

**CUT TO LENGTH.** To cut all the fronts to the same length, I clamped an L-shaped stop block to the table saw rip fence, see Fig. 4. This provides clearance so the cut-off won't bind between the rip fence and the saw blade.

**RABBETING.** After the fronts are cut to length, they're rabbeted to accept the sides and the bin bottom, see Fig. 5. To do this, attach an auxiliary fence to the table saw rip fence. Then set a dado blade to cut a rabbet 1/2" deep and wide enough to match

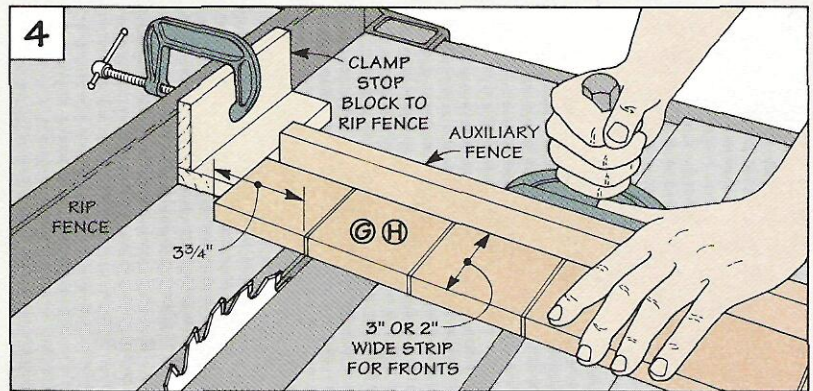
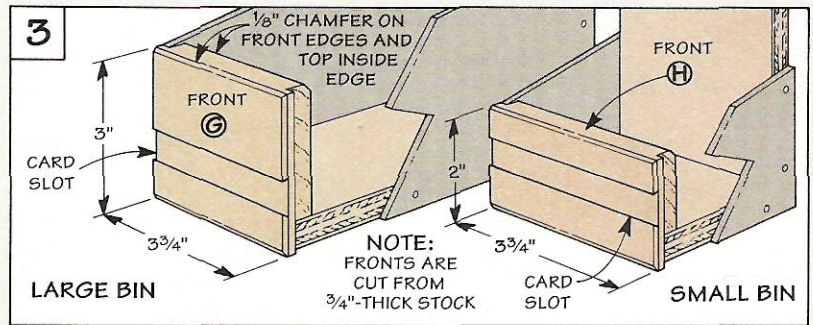

the thickness of the sides (1/8"), see Fig. 5a.

Note: To support the pieces while cutting the rabbets, I use a large push block, see Fig. 5.

Next, reposition the fence and cut another rabbet wide enough to fit over the bottom, see Fig. 5b.

**CHAMFERING.** I cut a small chamfer on the four outside edges of the bin fronts. I also chamfered the top *inside* edge, see Fig. 3.

**CARD HOLDER.** Finally, I routed a dovetailed slot across the front of the bin to hold a cardboard label, see Fig. 6.

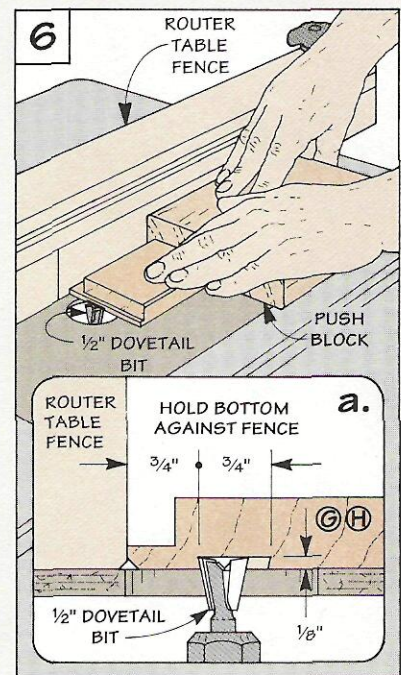
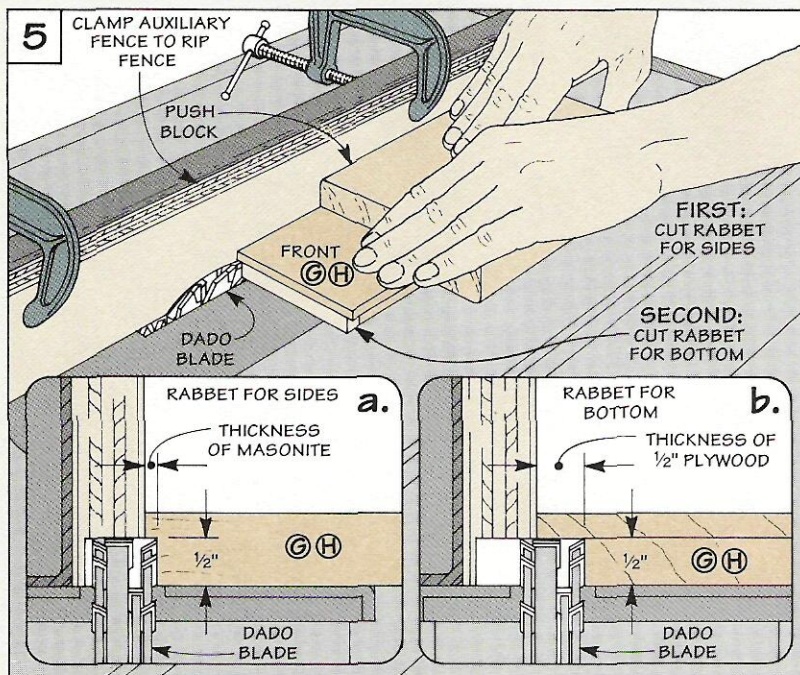

# Assembly

When all the parts are complete, you're ready to assemble them to make the bins.

Assembly is really very easy — the pieces are just glued and nailed together. The only thing you might want to do is to make a couple of spacer blocks to help center the dividers in the large bins, see Fig. 7.

Note: If you're assembling quite a few bins, the assembly jig shown below is a real time saver.

## RAILS

The bins are mounted to rails made from lengths of 2x4 stock, ripped 1½"-wide. The length of the rails is determined by the number of bins you want.

To form the retaining lip for the bins, cut a rabbet in the bottom back edge of each rail, see Fig. 8a. After the rabbets are cut, screw the rails to the wall, spacing them 4⅝" apart. Here again, a spacer block is handy, see Fig. 8.

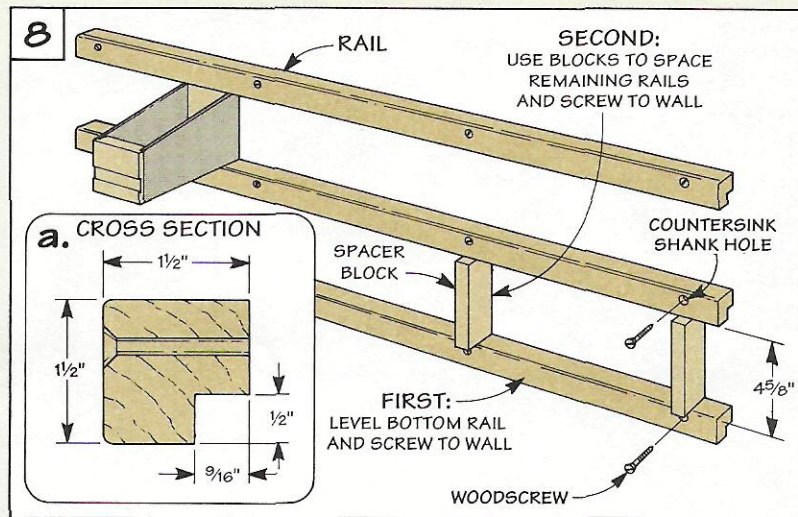
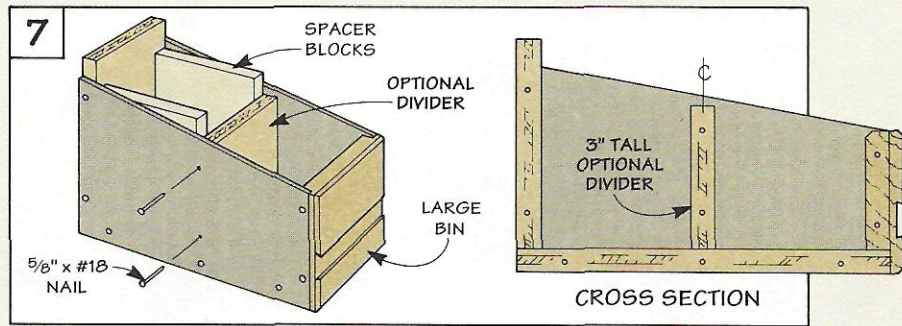

## Assembly Jig

Assembly is easier if you have a jig to hold the front, bottom and back of the bin in place while you glue and nail on one of the sides, see photo at right.

To make the jig, start by cutting a piece of ¾" scrap plywood to size, see Fig. 1. Then, cut a groove to hold the

bin's bottom. Next, cut two dados to position the backs of a large and small bin, see Fig. 1. Finally, cut a dado to hold the bin's front.

To use the jig, insert a front, back, and bottom. Then glue and nail on one of the sides, see Fig. 2.

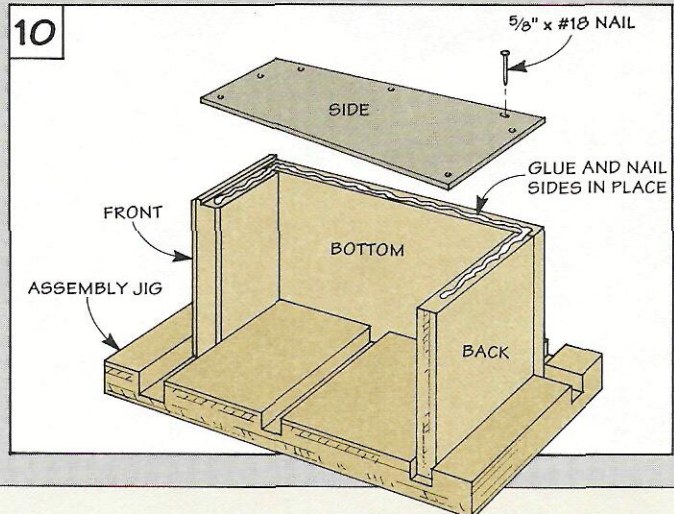
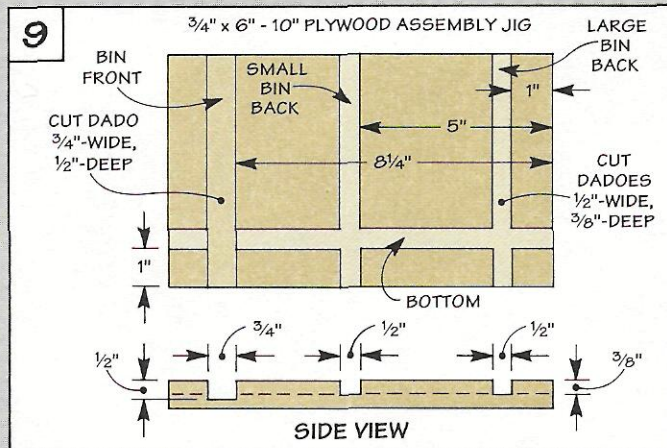
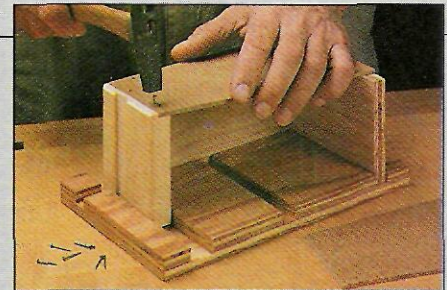

# Storage Bin Carrier

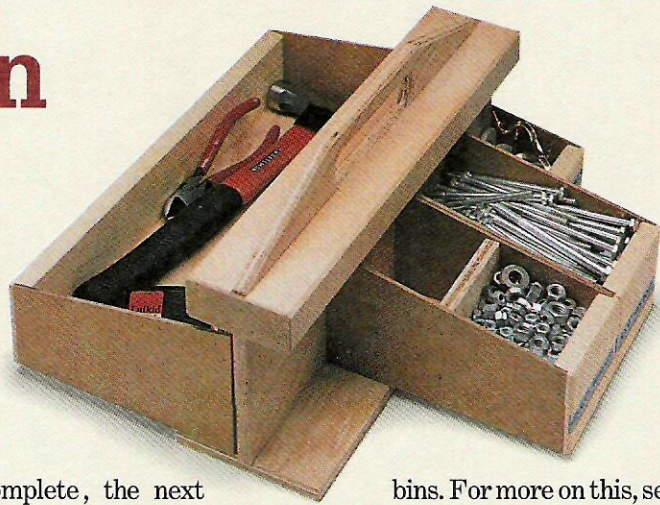

*Use this handy carrier to transport a few of your storage bins and some tools to the worksite.*

■ This carrier provides a convenient way to hold up to eight bins at once. Or you can make an extra-large tool bin to fit on one side, see photo at right.

The carrier consists of three main parts: a center divider, a base, and the rails, see Fig. 1.

**DIVIDER.** The first step is to make the  $\frac{1}{2}$ " plywood divider. The length of the divider determines the number of bins you can carry. I made the divider long enough to hold up to four bins on each side ( $15\frac{3}{4}$ ").

After determining the length, cut the divider to shape, see Fig. 2. Then drill and cut out the handle opening.

**BASE.** After the divider is

complete, the next step is to make the base. Cut the  $\frac{1}{2}$ " plywood base to the same length as the divider ( $15\frac{3}{4}$ "). Then rip the base to a finished width of  $4\frac{7}{8}$ ".

After the base is cut to size, cut an  $\frac{1}{8}$ "-deep groove down the center to hold the divider, see Fig. 1.

**RAILS.** Before assembling the carrier, cut two  $15\frac{3}{4}$ "-long rails from 2x4 stock. Then rabbet the inside edge of each rail to hold the

bins. For more on this, see page 19.

Now, assemble the carrier, and glue and nail on a couple of end caps made from  $\frac{1}{8}$ " Masonite, see Fig. 1.

## TOOL BIN

You can add a tool bin to fit the carrier, or to hang on the wall strips. The tool bin is made just like a large storage bin, except it has a longer back, bottom, and front, see Fig. 3.

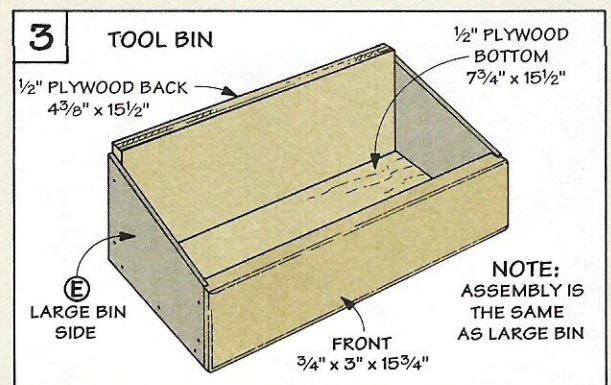
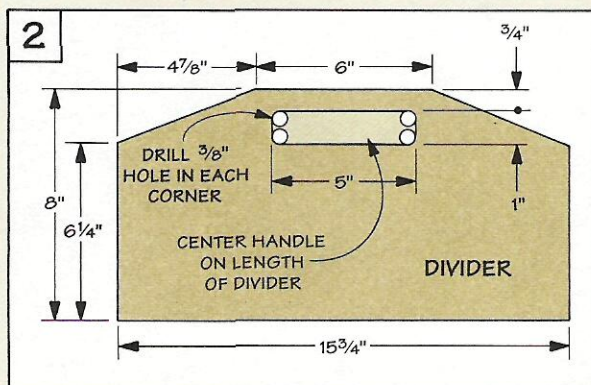
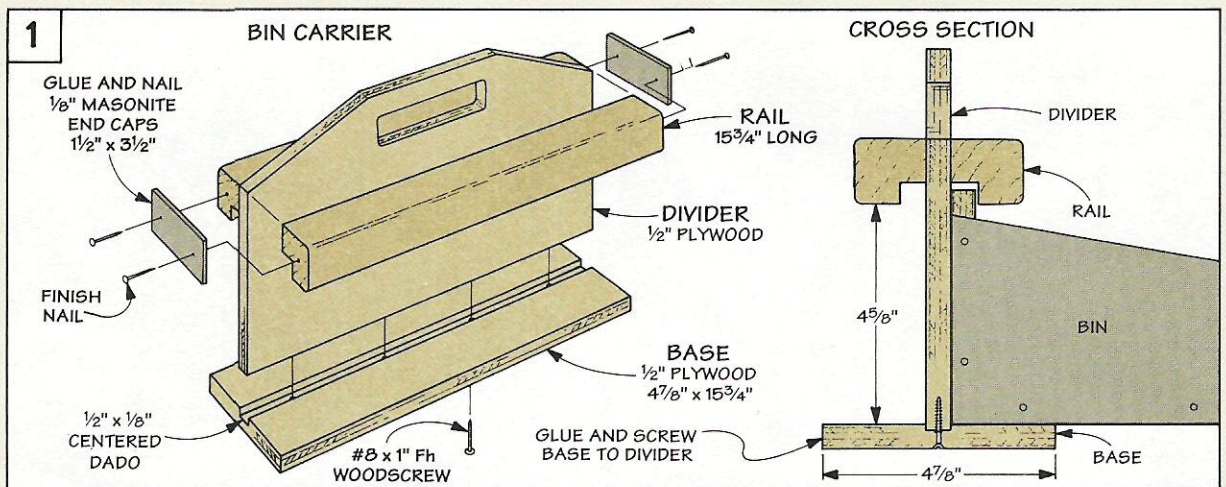

# Tape Dispenser

■ The storage bins lend themselves to all sorts of adaptations. One of the first modifications we made was to turn a large bin into a tape dispenser.

**CONSTRUCTION.** To make the tape dispenser, start by cutting a plywood *back piece*, two Masonite *side pieces*, and the solid wood *front* to size, see Fig. 1. (To provide clearance for standard rolls of tape, there is no bottom in the bin.)

When rabbeting the front piece, you only need rabbets for the sides. There's no need to rabbet the bottom edge (because there is no bottom). Also, you don't have to rout the card slot on the front.

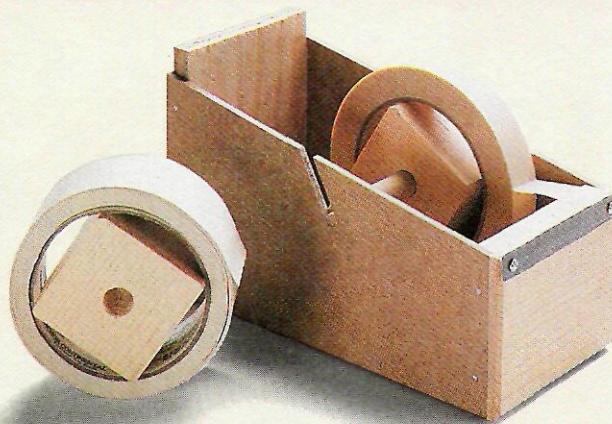

*This tape dispenser will hold a couple rolls of tape. And it hangs on the wall just like the storage bins.*

**SIDES.** The sides of the dispenser have an angled slot cut in them for a dowel that holds the tape in place, see Fig. 1.

I used a coping saw to cut the slot, see Fig. 1. Then I glued and nailed the dispenser together.

**CENTER DOWEL.** The rolls of tape are held in the bin with a block and a dowel, see Fig. 3.

The dowel is cut to length so it's the same length as the outside width of the dispenser ( $3\frac{3}{4}$ ").

Then a tenon is cut on each end

of the dowel that fits in the angled slots. To do this, clamp an auxiliary fence and a support jig to the table saw rip fence, see Fig. 2.

**BLOCK.** Next, cut a center block from a square piece of stock, see Fig. 3. Then chamfer the corners until it fits tight inside a roll of tape, and drill a hole to mount the dowel.

Finally, to make it easy to tear off the tape, screw a length of hacksaw blade to the front of the dispenser, see Fig. 3.

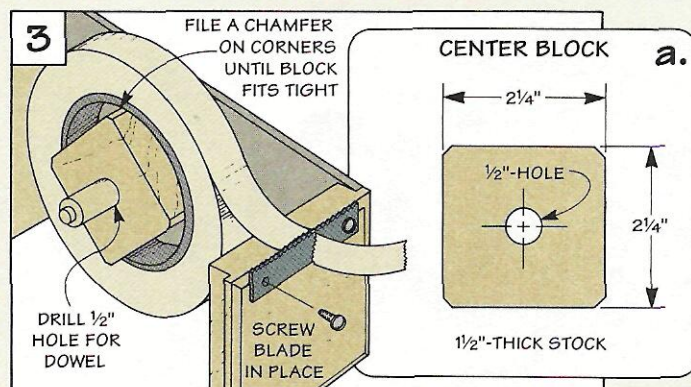
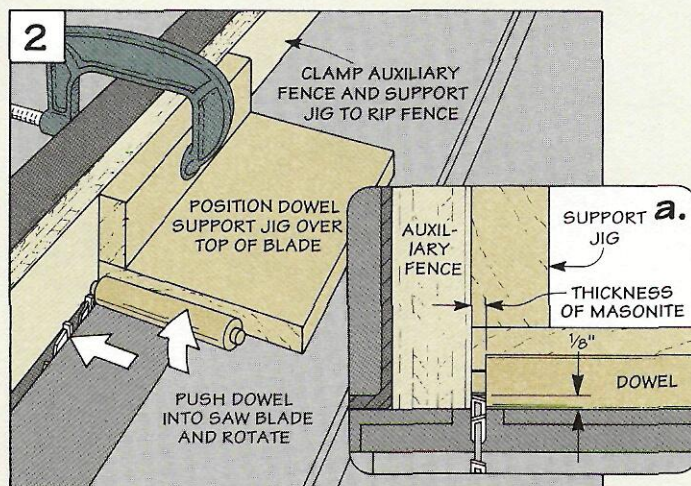
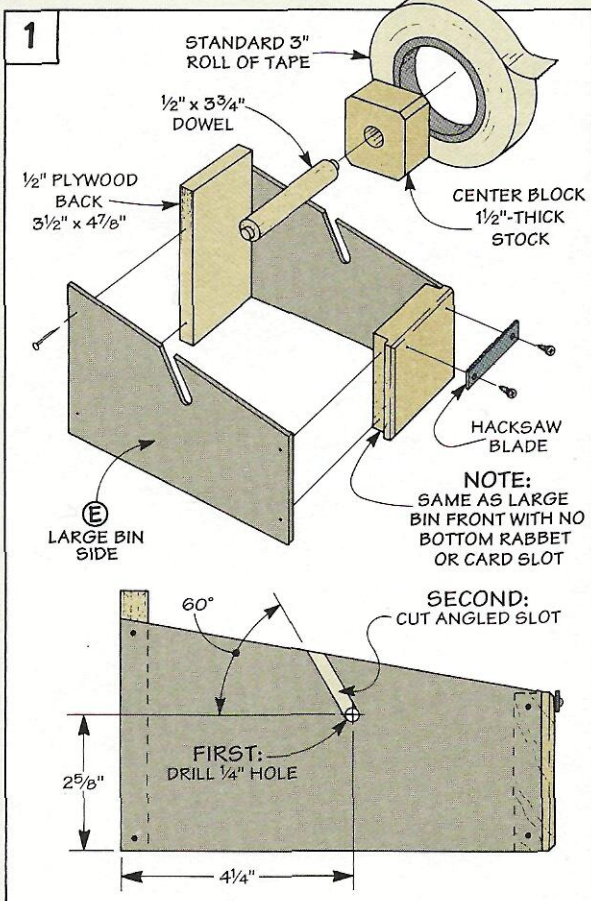

# Joiner's Mallet

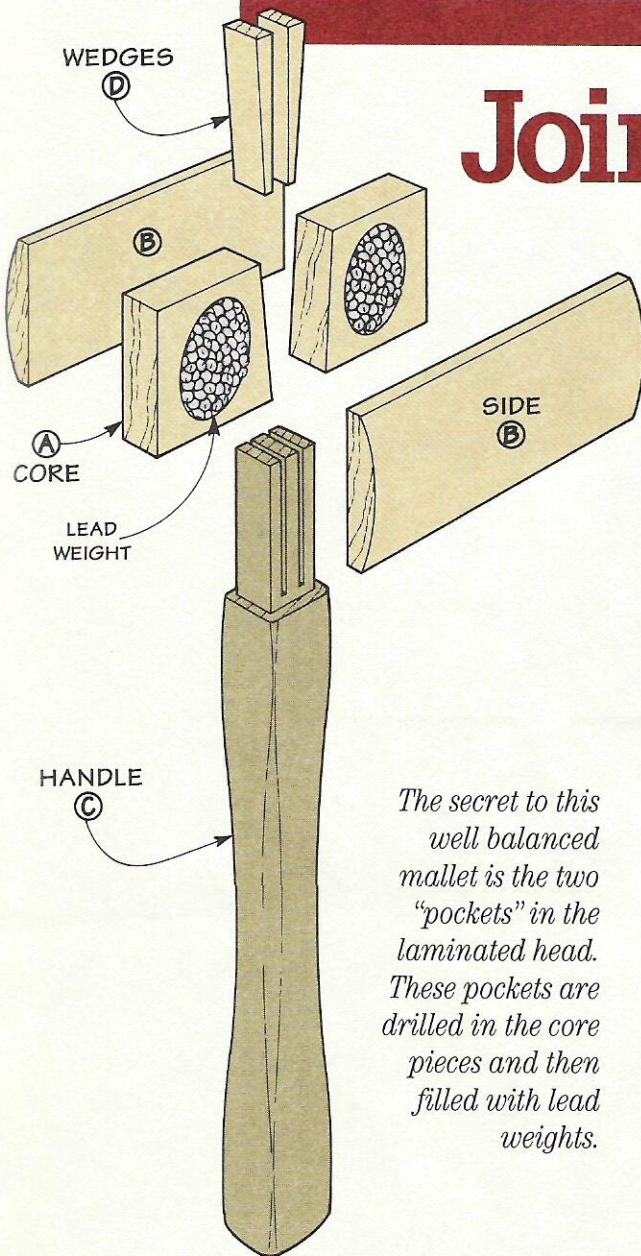

*The secret to this well balanced mallet is the two "pockets" in the laminated head. These pockets are drilled in the core pieces and then filled with lead weights.*

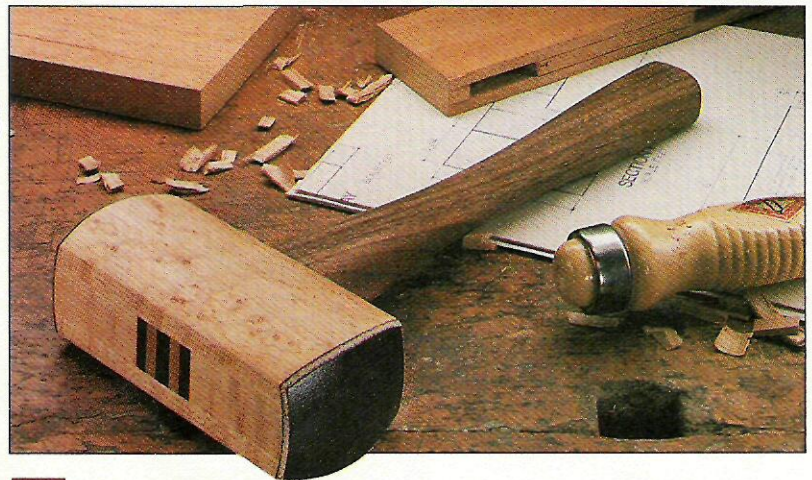

**T**here's something very satisfying about using a tool that you've crafted yourself. And this Joiner's Mallet is no exception. Every time I pick it up I enjoy its heft and balance, especially the way the handle fits my hand. That's something you just can't get from a store-bought tool.

The heft of this mallet comes from two round "pockets" in the head filled with lead sinkers, see drawing at left. To prevent the mallet head from marring the surface of a workpiece, I glued leather pieces onto both ends. (For sources of weights and leather, see page 31.)

## CONSTRUCTION

The first step is to make the head of the mallet. The head consists of two core pieces (A) and two sides (B), see drawing at left. The core pieces are drilled to make the "pockets" and shaped to form the tapered mortise for the handle.

**CORE BLANK.** To make the core pieces (A), start by cutting a 2 1/4"-wide core blank from 3/4"-thick stock, see Fig. 1. (I used hard maple.) I cut the blank extra long so I could safely drill the pockets and cut the short core pieces to length.

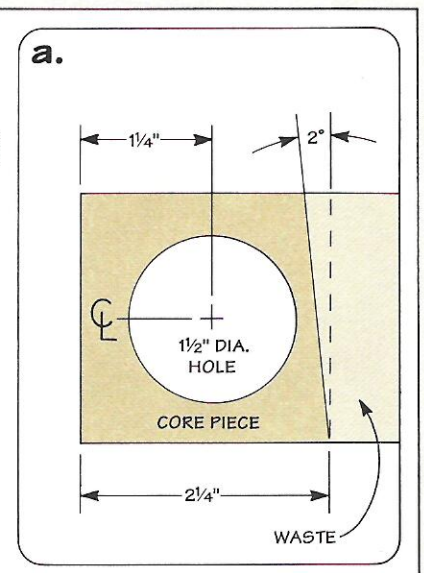
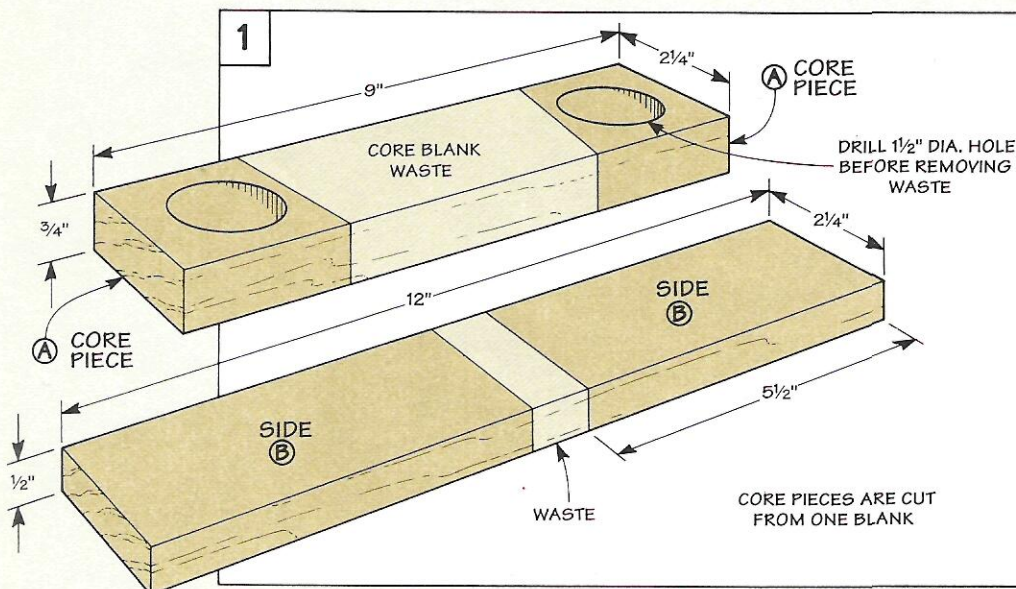

**POCKETS.** With the blank cut to rough size, lay out hole locations on both ends of the blank, see Fig. 1a. Then, drill the 1½"-dia. pocket holes at each end.

**CORE PIECES.** Once the holes are drilled, the next step is to cut the core pieces to length. These are cut at a slight angle (2°) to form a tapered mortise for the handle, see Fig. 1a. To do this, set your miter gauge at 2° and cut the core pieces off the blank, see Fig. 1.

**SIDES.** With the side pieces cut to length, work can begin on the ½"-thick sides (B). (Here again I used hard maple.) Each side is cut the same width as the core pieces (2¼") and 5½" long, see Fig. 1.

**GLUE-UP.** Once the sides are cut, the mallet head can be glued up. To do this, first glue the two core pieces to one side piece, see Fig. 2. Note: Make sure the core pieces form a tapered mortise, see Fig. 2.

The next step is to fill the pockets with weight, see Fig. 3. I used small lead fishing sinkers for this (3/0 size split-shot). This size makes it easy to pack them tight in the pockets.

To keep the sinkers from rattling, pour in some quick-set epoxy. Then, when the epoxy is dry, glue the remaining side in

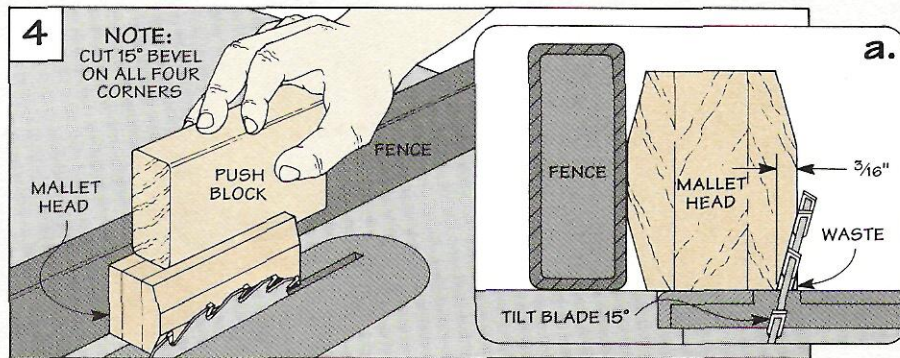
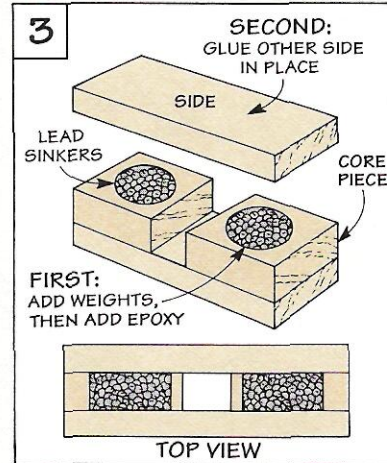
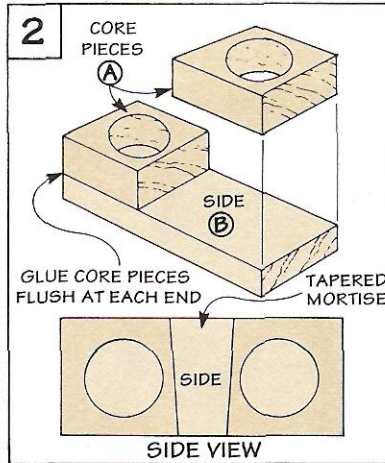

place, see Fig. 3.

**SHAPE HEAD.** The next step is to shape the head of the mallet by first cutting a bevel on all four corners, see Fig. 4. Then use a sanding block to shape the sides to a smooth curve, see Fig. 5. Next, sand a slight "crown" on both ends of the

mallet head, see Fig. 6.

**LEATHER.** Finally, I glued a leather face to both ends of the mallet head. Using contact cement, apply two coats of leather and to the ends of the mallet. Then press the leather in place and trim off the excess, see Fig. 7.

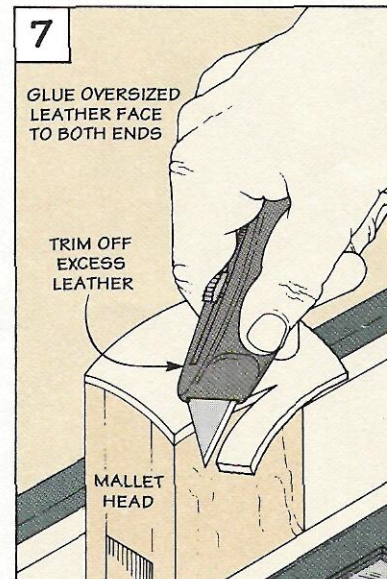
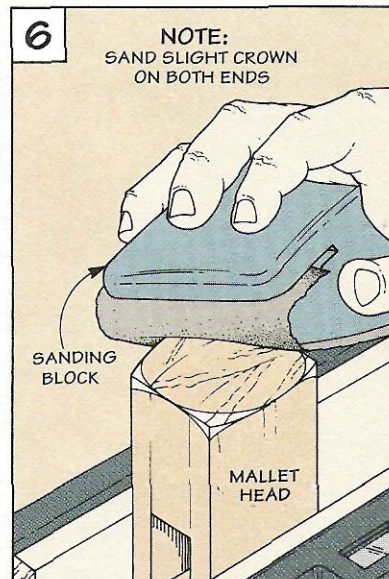
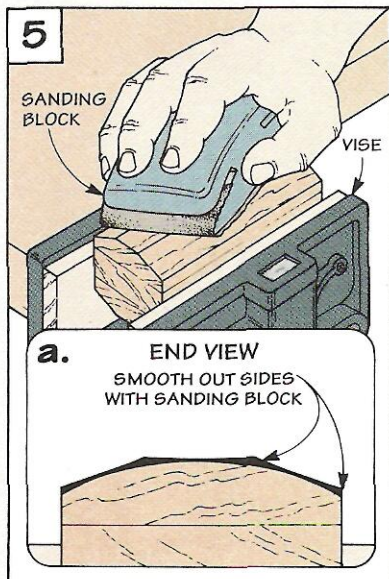

## Mallet Handle

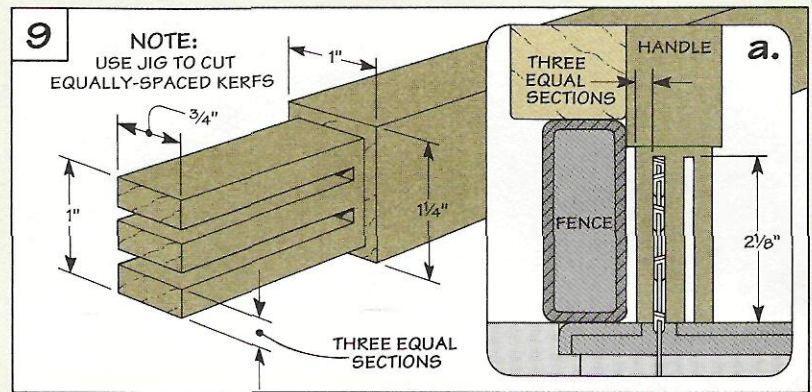
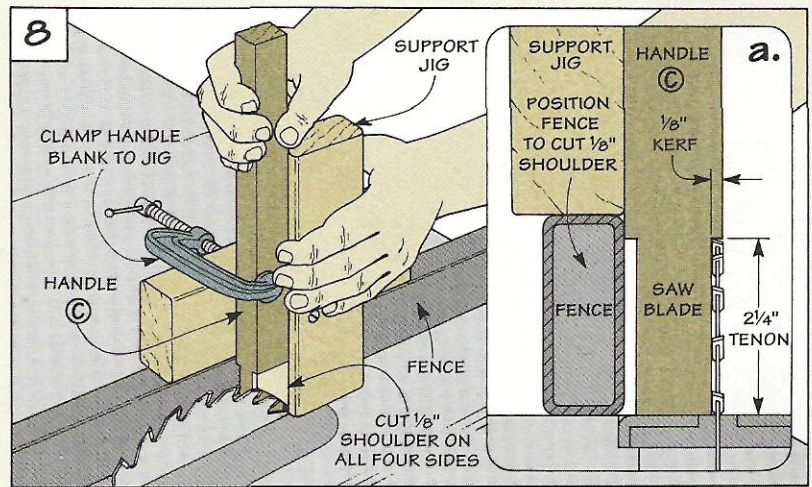
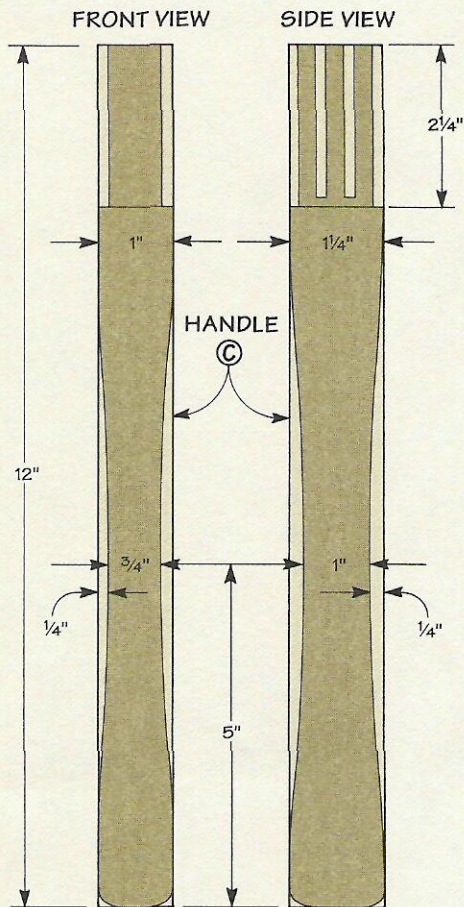

I used a piece of straight-grained walnut for the handle (but any hardwood will do). The overall length of the *handle* (C) is 12". The width and thickness is determined by the size of the mortise in the mallet head.

**HANDLE BLANK.** To determine the size of the handle blank, first measure the mortise at the bot-

tom (narrowest part) of the head. Then to allow for 1/8" shoulders on all four sides, add 1/4" to each measurement and cut the blank to these dimensions. (In my case, the blank is 1" thick and 1 1/4" wide.)

**CUT TENON.** After the handle is cut to size, the next step is to cut the tenon leaving 1/8" shoulders. To do this, I used the table saw

and a simple jig to support the blank, see Fig. 8.

The jig is just a scrap of 2x4 that's cut in two and screwed together to form a cross, see Fig. 8. It rides on both the rip fence and the table top to support the cut.

**WEDGE KERFS.** With the tenon cut, the next step is to cut the kerfs for the wedges that hold the head in place, see Fig. 9. To prevent the handle from splitting, cut the kerfs 1/8" less than the length of the tenon (2 1/8").

Position the rip fence so the 1"-wide tenon will be divided into three equal parts, see Fig. 9.

**SHAPE HANDLE.** Now that the kerfs are cut, the handle can be shaped to fit your hand, see the drawings at upper left. To do this, I use a file to get the handle to rough shape, see Fig. 10. Then use a scraper or sandpaper to remove the file marks.

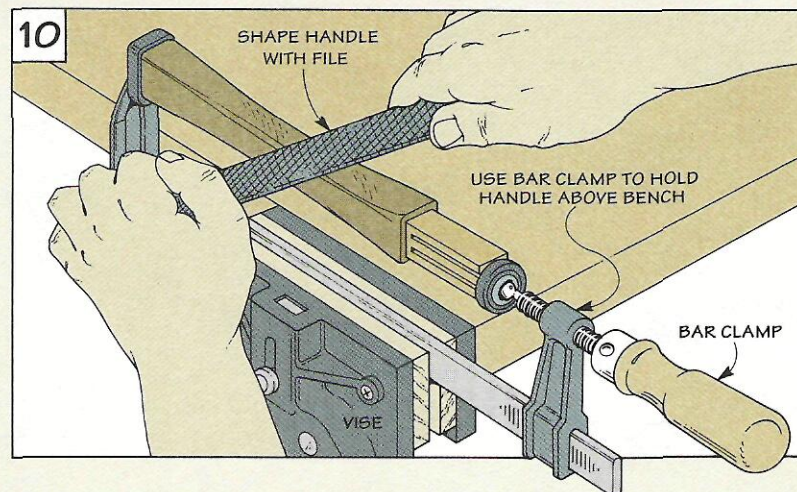



# Wedges and Assembly

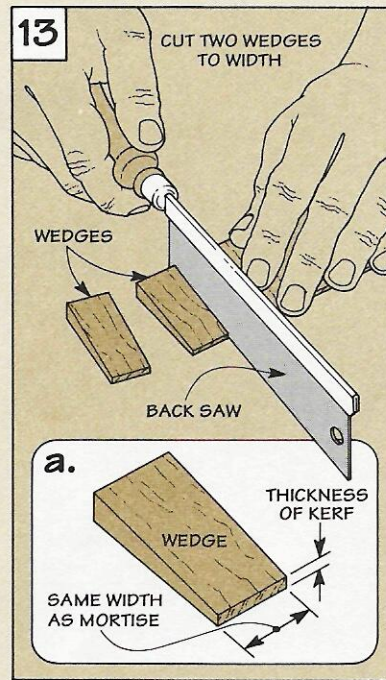
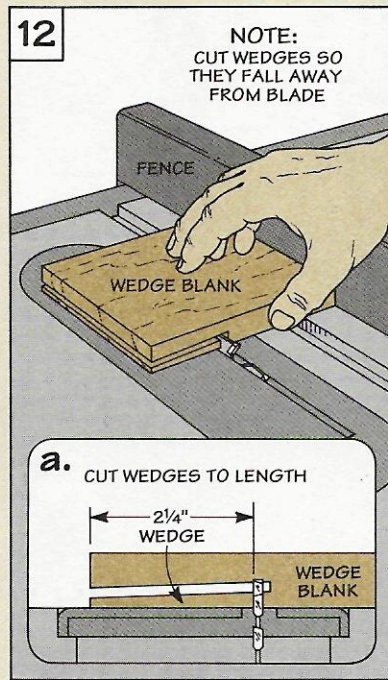
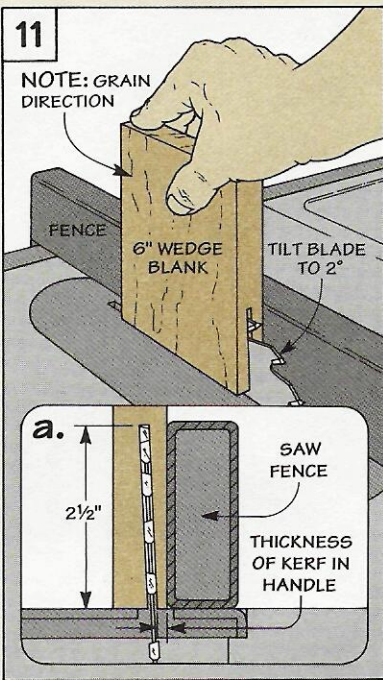

Now that you've completed the handle, work can begin on the wedges that hold the handle in the mallet head.

## WEDGES

I chose maple for the wedges and oriented the grain to run parallel to the sides of the wedge, see Fig. 11. Orienting the grain like this helps to prevent the wedges from breaking off when they're driven into the handle, refer to Fig. 14.

To hold the head securely in place, the wedges are tapered. The narrow end of the wedge is cut to match the width of the kerf in the handle. This ensures the wedges won't bottom out in the kerfs before the handle is tight in the mallet head.

**SET-UP.** To cut these small wedges safely, I use a two-step process and an oversized blank. To do this, start by positioning the rip fence on your table saw.

Adjust the rip fence so the distance between the blade and the fence is the same as the width of the kerf in the handle. Then, tilt the blade to match the taper of

the mortise (2°) and push the blank along the fence, see Fig. 11.

To cut the wedges to length, (and prevent the wedges from binding against the blade), position the rip fence so the wedges fall off to the left of the blade, see Fig. 12. (Note: The wedges are cut 1/8"-longer than the kerf in the handle. This allows you to trim them off for a perfect fit.)

Once the wedges are cut to fit the kerfs, you'll need to trim them to width (3/4", in my case). To do this, use a fine-toothed back saw to cut the wedges to width, see Fig. 13.

## ASSEMBLY

Once the wedges are cut, the mallet can be assembled. To do this, first apply glue to the handle tenon and slide it into the head, see Fig. 14.

Then, apply glue to the wedges and drive them into the handle. The trick here is to drive them both in at the same time. To do this, I placed a scrap block over both wedges to tap them in together.

Finally, sand or trim the wedges flush with the head, see Fig. 14a.

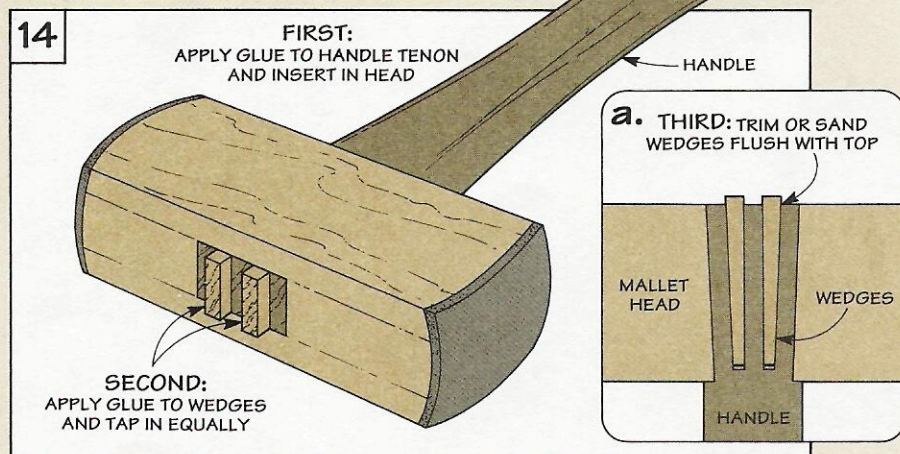

# Hand-Cut Mortises

*Cutting mortises by hand is fast and easy. The secret is combining the right tools with a simple technique.*

HEAVY DUTY BLADE

LEATHER WASHER

HARD-WOOD HANDLE

*Mortise chisels are identified by a stout blade. Some even have a leather "shock-absorber."*

**W**hen I've got a lot of mortises to cut, I use power tools. But when there's just a few to be cut, I like to do it by hand. There's no substitute for the feel of a chisel as it slices cleanly through a piece of wood. And cutting mortises by hand is surprisingly quick and easy.

## MORTISE CHISELS

The secret to cutting mortises quickly and easily is the mortise chisel. A mortise chisel is shaped differently than a standard chisel.

It has an extra strong blade and a stout handle to take the blows of a mallet, see drawing at left. Many mortise chisels also have a leather "shock-absorber" that's inserted between the blade and the handle.

To prevent the blade from bending when levering out the

waste, the blade is much thicker from front-to-back than other chisels. (Note: You could use a standard bevel-edge chisel to cut mortises, but you'd have to take very light cuts and there would always be the risk of breaking or bending the blade.)

**CHISEL SIZES.** Mortise chisels are commonly available in  $\frac{1}{16}$ " or 1mm increments. They can be purchased individually or in sets (see Sources, page 31).

A set of these chisels is expensive, so I'd suggest you start with a  $\frac{1}{4}$ " or 8mm chisel. This is the size I use most often to cut a  $\frac{1}{4}$ " mortise in  $\frac{3}{4}$ "-thick stock.

And this follows the general rule for sizing a mortise and tenon joint — the width of the mortise should be equal to about one-third of the thickness of the workpiece.

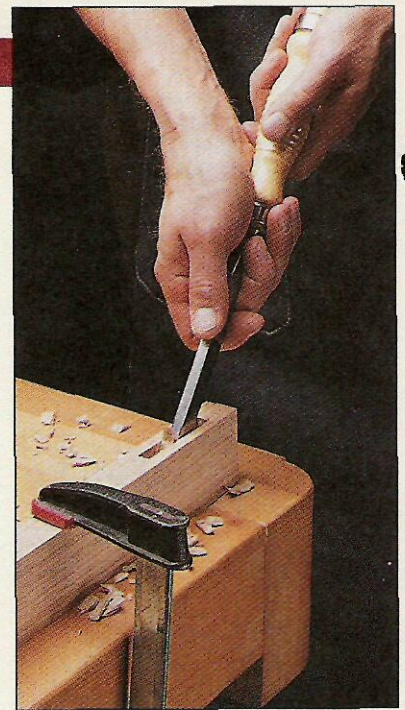

## LAY OUT MORTISE

In order to cut a mortise by hand, first you need to lay out the mortise. You can do this with a pencil, but I like to use a mortise gauge.

A mortise gauge is similar to a marking gauge except it has two pins instead of one, see drawings below. The pins on the gauge score the surface of the wood. And scoring the wood helps guide the mortise chisel during the first few cuts.

To use the gauge, first adjust the pins to match the mortise, see Step 1. Then, center the pins on the workpiece and mark the mortise, see Steps 2 and 3.

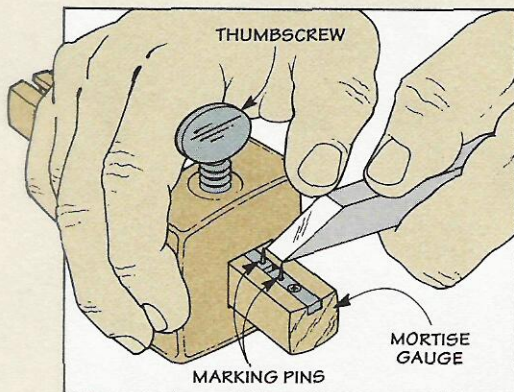

**Step 1:** Set the pins of the mortise gauge to correspond with the width of the blade of your mortise chisel. Then, lock the pins in this position.

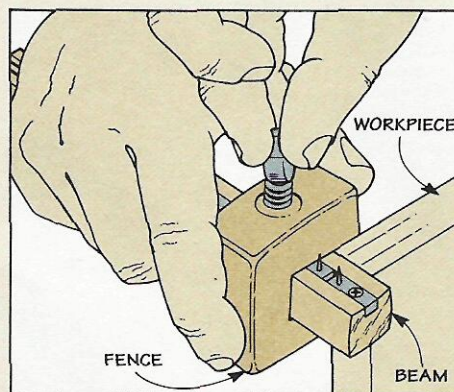

**Step 2:** Next, adjust the gauge so the pins are centered on the thickness of the workpiece. Then, tighten the screw to lock the beam in place.

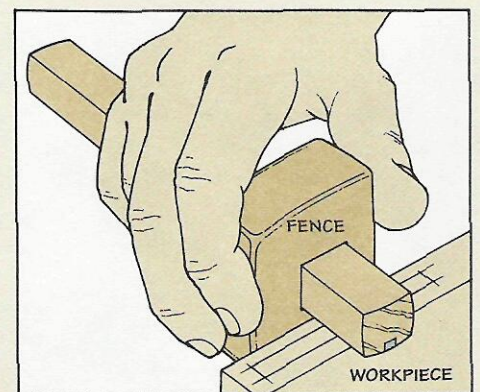

**Step 3:** Now press the fence against the edge of the workpiece. Then push or pull the gauge so the pins score lines to mark the cheeks of the mortise.

# Cutting Mortises Step-by-Step

Once the mortise is laid out, the next step is to secure the workpiece. I prefer to clamp the workpiece on the top of the bench (over a leg if possible).

**A RAMP.** The secret of hand cutting a mortise is to create a "ramp" inside the mortise.

To prevent crushing the ends of the mortise when cleaning it out, start the ramp  $\frac{1}{8}$ " in from each end of the marked mortise. Then begin cutting the ramp down toward one end of the mortise, see Steps 1 and 2.

Once the full depth is reached, remove the remaining waste, see Steps 3 to 5.

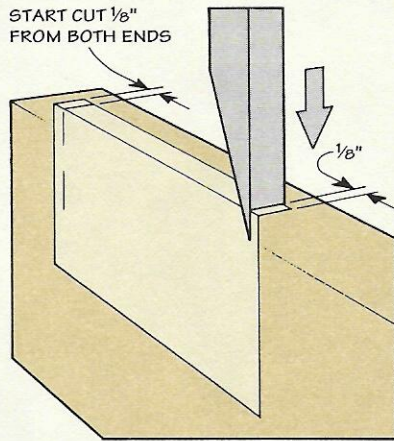

**Step 1.** With the flat of the chisel toward the end of mortise, use a mallet to drive the chisel vertically into the wood about  $\frac{1}{4}$ ".

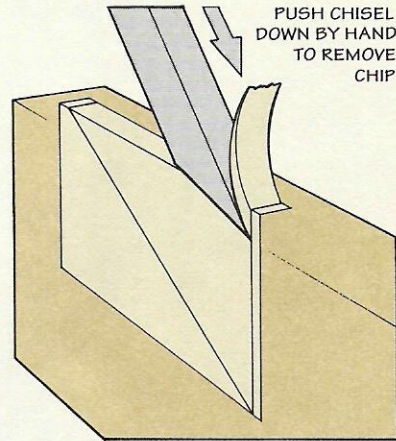

**Step 2.** With the bevel down, remove a chip. To prevent crushing the ends of the mortise, leave  $\frac{1}{8}$ " at each end of the mortise.

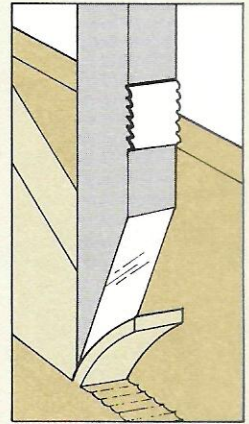

Stick a piece of tape on the chisel to act as a depth gauge.

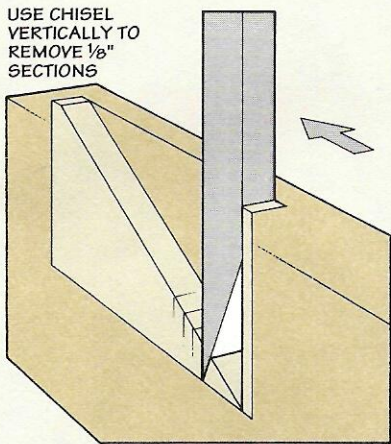

**Step 3.** To clean out the remaining waste, hold the chisel with the bevel toward the low end of the ramp and chisel out  $\frac{1}{8}$ " sections.

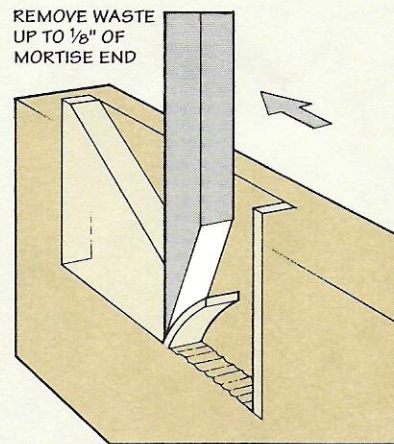

**Step 4.** Continue in this manner for the entire length of the mortise. Taking  $\frac{1}{8}$ " cuts and prying out the waste.

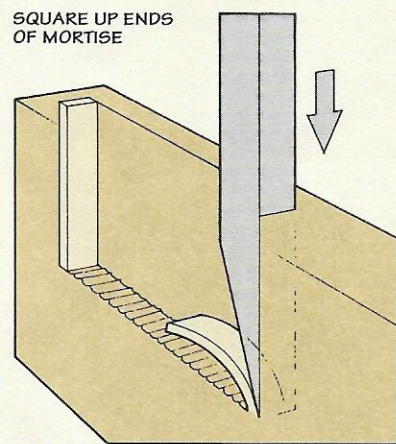

**Step 5.** Finally, to complete the mortise, pare away the  $\frac{1}{8}$ " section that you left at each end of the mortise.

## Cutting Long Mortises

If you need to cut a longer mortise, cut two "ramps" that bottom out in the middle of the mortise, see Steps 1 and 2. Then remove the waste as you did before.

To prevent the wood on the end of the workpiece from chipping out, take very light vertical cuts with the chisel and don't try to pry out the chips. Instead, use the chisel with the bevel down to cut away the end waste.

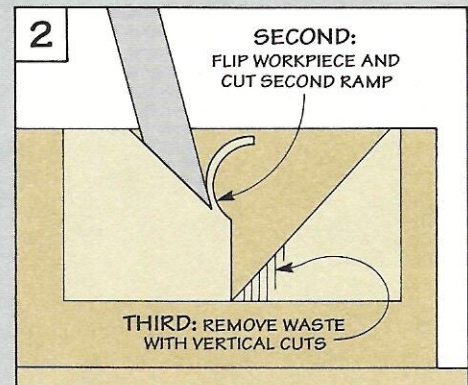
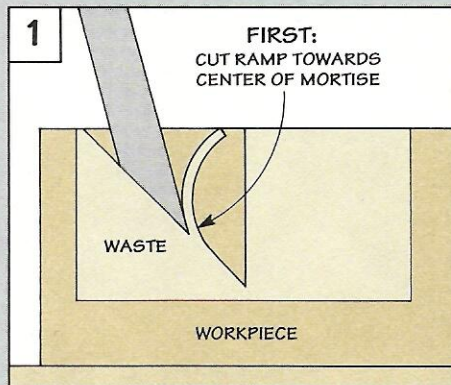

# Shop Solutions

## Countersink and Bit Organizer

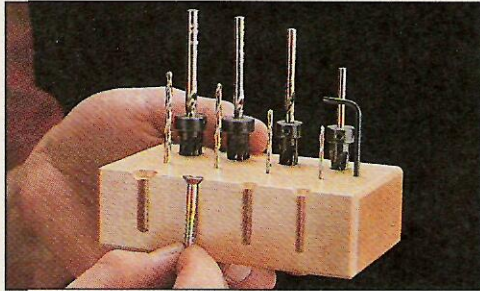

■ When drilling a hole for a wood-screw I use two different size bits to drill a shank hole and pilot hole.

I drill the shank hole with a bit fitted with a countersink. To keep the screw threads from catching in the hole, I use a slightly larger bit than the screw diameter.

The pilot hole is drilled in the adjoining piece and is sized so the screw threads will dig in.

The problem is remembering which set of bits goes with which screw. So I built an organizer with a cutaway view of the countersunk shank holes to tell me at a glance which bits to use with the common screw sizes (#6, #8, #10, and #12), see photo above.

To make the organizer, first cut a 2x4 scrap long enough to hold the bits, see Fig. 1. Then, drill the correct size pilot holes down the center of the piece. (I also drilled

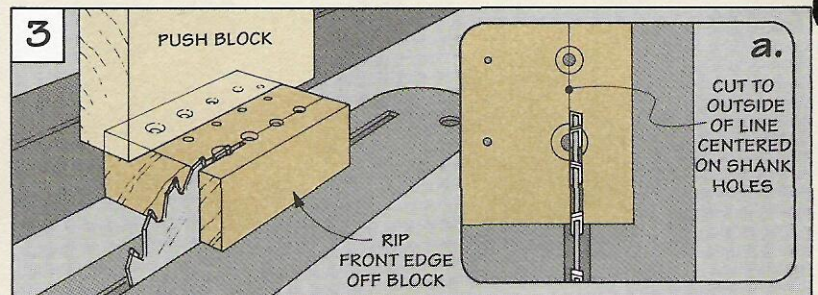
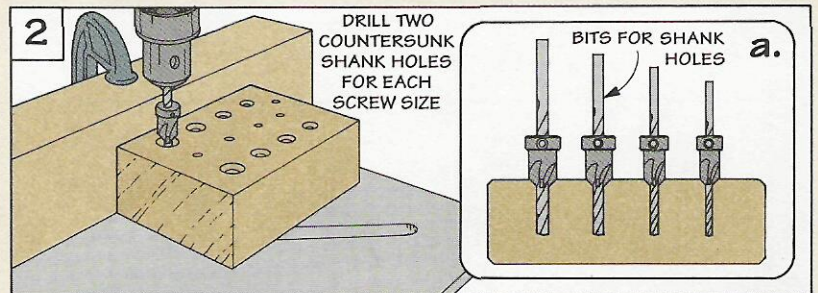
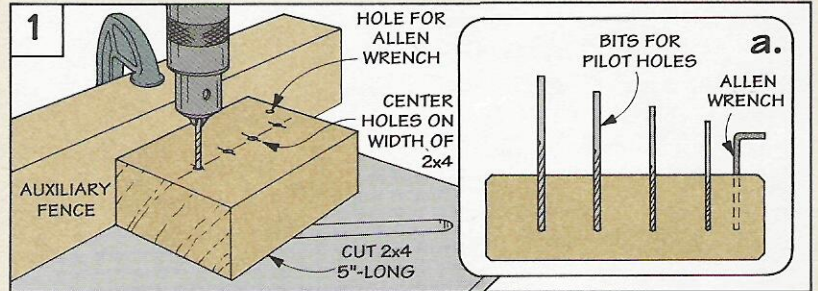

one more hole to hold the Allen wrench that adjusts the countersinks.) Next drill corresponding countersunk shank holes on *both*

sides of the pilot holes, see Fig. 2.

Finally, to produce the cutaway view, rip the front edge off the block, see Fig. 3.

## Framing Square

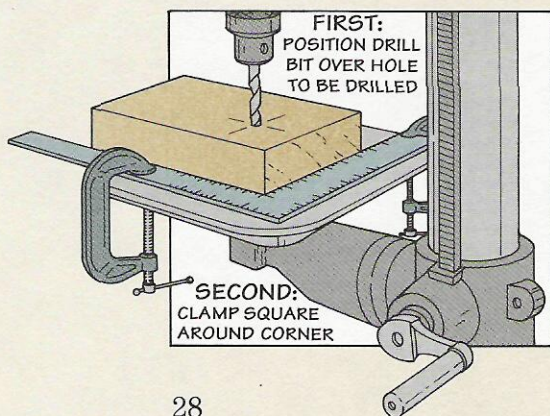

■ A lot of projects require drilling holes positioned in the same place on a number of pieces. But setting up a fence and stop block to position a workpiece can take a bit of time.

A quick way to do this is to clamp a framing square to the drill press table, see drawing at left. The inside corner of the framing square substitutes for the typical fence

and stop block arrangement, and it's a perfect 90°.

To use the square, first place the drill bit over the hole to be drilled. Then position the framing square around the corner of the workpiece, and clamp the square to the table.

To locate the holes on the remaining pieces, just slide each piece into the corner of the square.

## Finishing Stand-Offs

■ Here's an easy way to keep small projects up off the bench (or floor) while finishing.

Start by sharpening both ends of 1/4" dowel cut-offs in a pencil sharpener. Then punch one end of each dowel into a piece of scrap foam insulation and rest the project on the other end. I use polystyrene (blue or pink) insulation. (This is often used around the foundations of new houses.) Besides holding the dowels, the insulation protects your bench from accidental spills and drips.

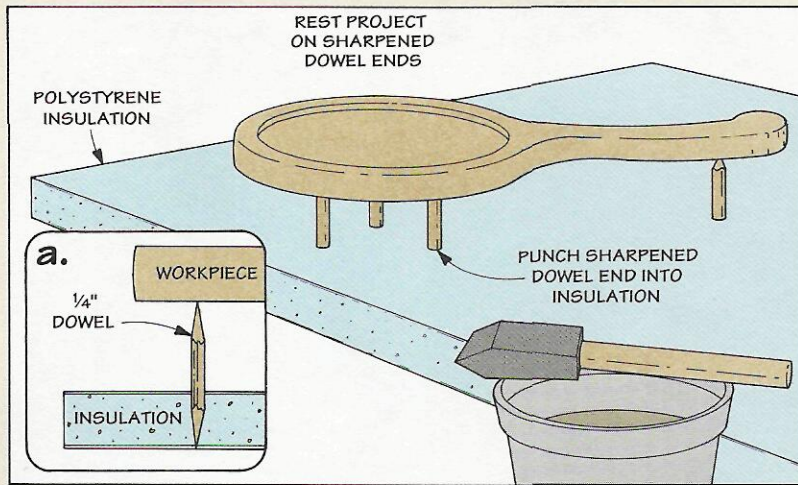

## Radial Arm Saw Depth Stop

■ To prevent the blade of my radial arm saw from cutting too deeply into the table, I clamped a depth stop to the column of the saw, see drawing at right. When the blade is lowered, the stop hits the column casting which stops the blade's downward travel.

The depth stop is just a piece of wood attached to the column with a hose clamp I picked up at the local hardware store, see Fig. 2b.

To determine the length of the stop, adjust the blade so it scores the surface of the table, see Fig. 2a.

Then cut a piece of scrap wood to fit between the column castings. Now fit the hose clamp around the column, insert the stop, and tighten the clamp down.

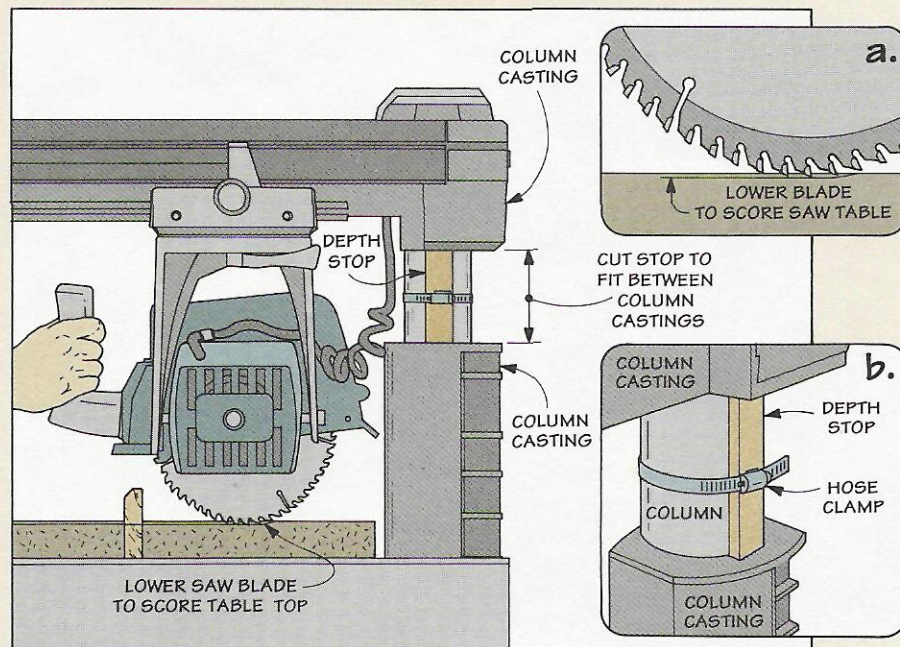

## Glue-Up Tip

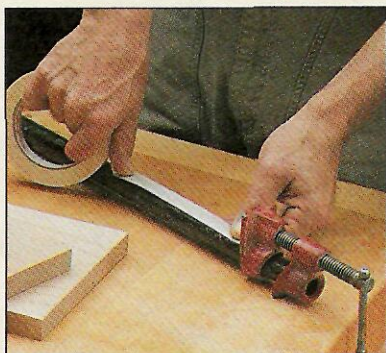

■ When gluing up a project, I used to lay wax paper between my pipe clamps and the wood to keep the glue off my clamps. The problem was the wax paper kept sliding off the clamps.

Now, I simply run a strip of masking tape along the length of the pipe clamp. Any glue that squeezes out is easily removed along with the tape.

## Send in Your Solutions

Finding solutions to problems is a part of woodworking. If you'd like to share solutions to problems you've faced, send them to: *ShopNotes*, Attn: Shop Solutions, 2200 Grand Ave., Des Moines, IA 50312.

We'll pay upon publication up to \$200 depending on the published length. Please send an explanation along with a photo or sketch.

# Soss Hinges

Recently I was installing a set of Soss Invisible Hinges on a cabinet door. Everyone who came in the shop picked up one of the hinges and spent several minutes just opening and closing it, admiring the action. Then they started to ask questions.

Although I've worked with Soss hinges for years, I didn't know much about their origin or history. To find out more, I called Neil Marko of the Universal Industrial Products Company that manufactures Soss hinges.

Neil told me the hinges have been around since 1903. Joseph Soss got the idea for a concealed hinge after tripping on a hinge

that projected from the deck of a ship. Before the ship docked, he had designed and built a prototype for an invisible hinge.

**USES.** Originally, Soss' best customers were automakers who installed the hinges on car doors. Today, the hinges are used on projects from small music boxes to 500-pound doors.

**HINGE MECHANISM.** The key to this hinge is the "knuckle" mechanism. It's a set of boomerang-shaped links connected by a riveted hinge pin, see drawing below. As the hinge closes, the links fold *inside* the body of the hinge — and disappear.

**MORTISE.** The first question

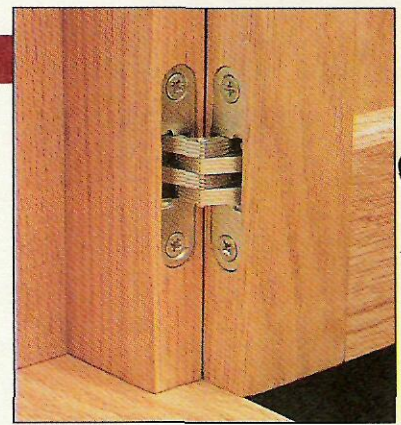

▲ The laminated links of this Soss Invisible Hinge slide inside the body. This conceals the hinge when it's closed.

that arises with this hinge is how do you cut the mortises?

Granted, these are no ordinary mortises. The flange of the hinge fits in a long, shallow mortise, while the central body mounts into a deep mortise. When the hinge is screwed in place, it should fit like a nut in a shell.

Cutting a mortise to the close tolerances required is a challenge. I usually use a Forstner bit to drill a series of holes to create the two-tier mortise, as shown in the box below.

**TEMPLATE.** Fortunately, locating the mortise holes is relatively easy because each pair of Soss hinges comes with a template to position the hinge.

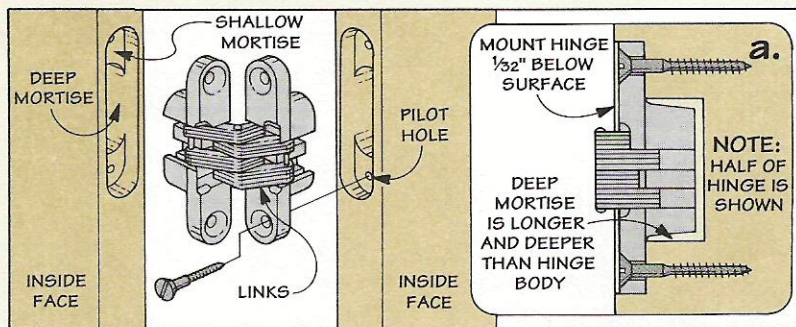

## Installing a Soss Hinge

To install a Soss hinge, position the template that comes with the hinge on the door and frame, and mark the holes for the mortises, see Fig. 1.

Then align the centerpoints to the

center of the bit, and clamp a fence to the drill press table, see Fig. 2. Now drill holes for the deep mortise to house the body of the hinge.

Next drill a shallow mortise for the

mounting flange, see Fig. 3. (I recess the mounting flange  $\frac{1}{32}$ " below the surface, see detail above.)

Finally, use a chisel to clean up the cheeks of the mortise to fit the hinge.

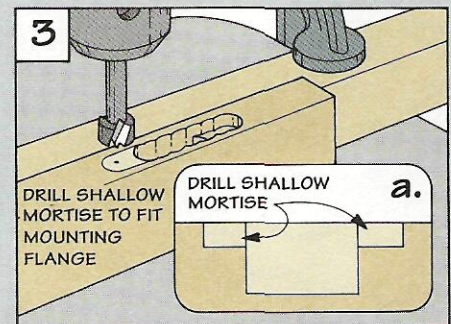
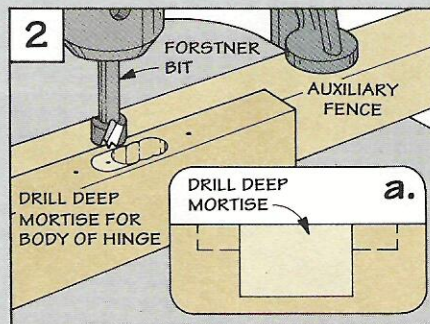
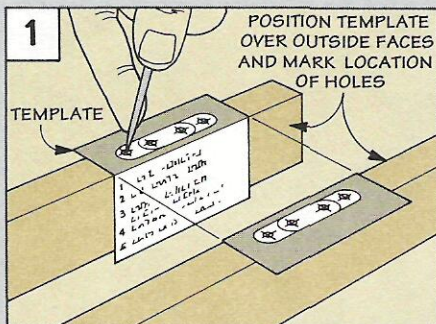

# Sources

■ *ShopNotes Shop Supplies* is offering some of the hardware and supplies needed for the projects in this issue.

We've also put together a list of other mail order sources that have the same or similar hardware and supplies.

## RADIAL ARM SAW FENCE

There's a hardware kit available for the Stop Block and the Hold-Down that we used on the Radial Arm Saw Fence, see page 9.

These kits contain hardware only (no wood).

### STOP BLOCK HARDWARE KIT.

- (1) T-Slot Nut
- (1) 5/16" x 1" Star Knob
- (1) 5/16" Washer

**S6802-100** Stop Block Hardware Kit.....\$4.95

### HOLD-DOWN HARDWARE KIT.

This kit contains all of the hardware listed above plus:

- (1) 1/4" x 3" Carriage Bolt
- (1) 1/4" Plastic Wing-Nut
- (1) 1/4" I.D. Threaded Insert
- (1) 1/4" Hex Head Nut

**S6802-150** Hold-Down Hardware Kit.....\$7.95

## SCRAPERS

The following items are available

through *ShopNotes Shop Supplies*. These items are also available from some of the other mail order sources listed below.

**SCRAPER.** Scrapers come in a wide variety of sizes and are manufactured by several companies.

We are offering a rectangular scraper that is made by Sandvik. This scraper is made of Swedish steel and comes with a special sleeve to protect the edges.

**S5005-163** Scraper..... \$7.95

**SMOOTH MILL FILE.** Before you can get a scraper to work properly, the edges need to be filed. I use a 10"-smooth mill file.

**S5001-103** 10" Smooth Mill File w/Handle..... \$8.95

**BURNISHER.** After filing the edge of the scraper, a burnisher is used to compact the steel and to roll the cutting burr. Burnishers come in several different shapes.

The type you use is a matter of personal taste. I prefer a round burnisher and that's what *ShopSupplies* is offering.

**S5005-105** Burnisher..... \$9.95

## JOINER'S MALLET

To get the right balance and heft in the shop-made Joiner's Mallet (shown on 22), I put lead weight

in the mallet head. Then I covered the ends of the mallet head with leather.

*Shop Supplies* is offering a kit that includes:

- 12 oz. of lead shot
- (1) 6 oz. piece of leather (large enough for both ends of the mallet).

**S6802-200** Mallet Kit.....\$2.95

## ROUTER BITS

On a couple of the projects in this issue (Drill Press Caddy, Storage Bin System) we used a chamfer bit to rout the edge.

We also used a dovetail bit to rout a label slot on the front of the storage bins.

These bits are high quality carbide tipped and are available through *Shop Supplies* and several of the sources listed below.

**S1514-170** Chamfer Bit 1/4" shank.....\$21.95

**S1512-175** Chamfer Bit 1/2" shank.....\$23.95

**S1514-550** Dovetail Bit 1/4" shank.....\$15.95

## SOSS HINGES

These special invisible hinges are available through some of the mail order catalogs listed below.

## MAIL ORDER SOURCES

Similar hardware and supplies may be found in the following catalogs. Please call each company for a catalog or for ordering information.

**Constantine's**  
800-223-8087  
Soss Hinges, Scrapers,  
Burnishers, Router  
Bits

**Highland Hardware**  
800-241-6748  
Router Bits

**Trend-Lines**  
800-767-9999  
Router Bits

**MLCS**  
800-933-9298  
Router Bits

**Woodcraft**  
800-225-1153  
Scrapers, Burnishers,  
Router Bits, Soss Hinges

**The Woodworkers' Store**  
612-428-2199  
Scrapers, Burnishers,  
Router Bits, Plastic  
Wing-Nut, Soss Hinges

**Woodworker's Supply**  
800-645-9292  
Scrapers, Router Bits

**Woodhaven**  
800-344-1153  
Router Bits

**Tandy Leather**  
817-551-9770  
Leather

**Garret Wade**  
800-221-2942  
Scrapers, Burnishers,  
Router Bits

**Shopsmith**  
800-543-7586  
Scrapers, Burnishers,  
Router Bits

## ORDER INFORMATION

### BY MAIL

To order by mail, use the form enclosed with a current issue. The order form includes information on handling and shipping charges, and sales tax. Send your mail order to:

**ShopNotes  
Project Supplies  
P.O. Box 842  
Des Moines, IA 50304**

### BY PHONE

For fastest service use our Toll Free order line. Open Monday through Friday, 8:00 AM to 5:00 PM Central Time.

Before calling, have your VISA, MasterCard, or Discover Card ready.

**1-800-444-7527**

Note: Prices subject to change after June 1, 1992.



## Scenes From the Shop

*This self-feeding post drill was the predecessor to today's modern drill press. As the handle is turned, the*

*wheel on the top turning the bit while forcing it down into the workpiece. For a quick return, the ratchet on top swings out of the way so the wheel can be turned by hand.*