

T I P S • T O O L S • T E C H N I Q U E S

ShopNotes™

Vol. 2

Issue 7



- Shop-Built Workbench
- Keyless Chuck Review

- Raised Panel Routing Jig
- Rust Removal Techniques



ShopNotes

Issue 7

January 1993

- EDITOR** Donald B. Peschke
EXECUTIVE EDITOR Douglas L. Hicks
MANAGING EDITOR Terry J. Strohmman
ASSOCIATE EDITOR Richard S. Peters
ASSISTANT EDITOR Tim Robertson
CONTRIBUTING EDITOR Phillip A. Totten
- CREATIVE DIRECTOR** Ted Kralicek
ART DIRECTOR Cary Christensen
SENIOR ILLUSTRATOR Kurt Schultz
ILLUSTRATORS Will Niskanen
 Roger Reiland
 Mark Higdon
PHOTOGRAPHER Crayola England
- DESIGN DIRECTOR** Ken Munkel
SENIOR DESIGNER Jan Hale Svee
DESIGNER Kent Welsh
SHOP MANAGER Steve Curtis

CIRCULATION

Circulation Director: Liz Bredeson • Subscription Manager: Phyllis Jessen • Circulation Analyst: Rod Cain • Newsstand Sales: Kent A. Buckton

PUBLISHING SERVICES

Associate Editor: Gordon C. Gaippe • Sr. Graphic Designer: Robert H. Whitmer

CORPORATE SERVICES

Controller: Paul E. Gray • Accounting: Linda O'Rourke • Bookkeeping: Julianne Spears • Info. Services Manager: Joyce Moore • Network Admin.: Douglas M. Lidster • Administrative Assts.: Cheryl Scott, Julia Fish • Receptionist: Jeanne Johnson • Bldg. Maint: Ken Griffith

PROJECT SUPPLIES

Marketing Director: Robert Murry • Art Director: Cindy Jackson • Customer Service Mgr.: Laura McNelly • Project Supplies: Linda Jones • Technical Support: Jeff Janes • Systems Operator: Linda Morrow • Receptionist: Kerl Lee

CUSTOMER SERVICE

Service Supervisor: Jennie Enos • Customer Service Representatives: Jennifer Murphy, Joy Johnson, Sara Kono, Ami Blanshan, Anna Cox, Chris Lo

SHIPPING DEPARTMENT

Supervisor: Jerry Carson • Fulfillment: Gloria Sheehan, Don McVey, Chuck Carlson, Sylvia Carey

ShopNotes (ISSN 1062-9696) is published bimonthly (January, March, May, July, September, November) by Woodsmith Corporation, 2200 Grand Ave., Des Moines, IA 50312. Printed in U.S.A.
ShopNotes is a trademark of Woodsmith Corporation. ©Copyright 1993 by Woodsmith Corporation. All rights reserved.
Subscriptions: Single Copy, \$4.95. One year subscription (6 issues), \$19.95. Two years (12 issues), \$35.95. Canada/Foreign, add \$4.00 per year.
Second Class Postage Paid at Des Moines, IA and at additional offices.
Postmaster: Send change of address to ShopNotes, Box 11204, Des Moines, IA 50340-1204
Subscription Questions? Call 1-800-333-5854, 8am to 5pm, Central Time, weekdays.

EDITOR'S NOTE

How many times have you heard, "that's the way it has always been done."

All too often woodworkers get "bogged down" thinking about the way things *should* be done, and we don't think about the way things *could* be done.

WORKBENCH. A perfect example of this is the Workbench featured in this issue. Traditionally the top of a workbench is glued up from several pieces to form a large, thick slab.

This requires a large amount of wood (which can be expensive). And a good deal of time and effort.

What we wanted was the look of a traditional bench without the work.

Kent Welsh (our Designer) came up with a different approach. The top of the bench starts with a plywood foundation. Then thin hardwood strips are glued on. Less wood, less effort.

PUBLISHER'S STATEMENT. You've probably noticed that a good portion of

this page is taken up by a rather official looking document. It's called a Publisher's Statement. Once a year the Post Office requires us to print this. Basically it lets everyone know how many issues are printed, and how they're distributed.

Now, I'll admit that I sometimes loose track of time, but when Phyllis Jessen (our Subscription Manager) reminded me to include the Publisher's Statement in this issue, I was shocked.

Having to fill out the the Publisher's Statement was like getting a birthday card. It reminded me that one year had passed since ShopNotes was "born."

The past year has been very exciting (and very busy) for all of us. The response to ShopNotes has been better than we hoped. We now have over 165,000 paid subscribers.

I want to thank all of you for helping us through the first year. And to let you know that we have lots of great projects planned for the future.

STATEMENT OF OWNERSHIP, MANAGEMENT AND CIRCULATION (Required by 39 U.S.C. 3685)

1. Title of Publication: ShopNotes. 1a. Publication No.: 10629696. 2. Date of Filing: September 24, 1992. 3. Frequency of issue: Bimonthly. 3a. No. of issues published annually: 6 (six). 3b. Annual subscription price: \$19.95. 4. Complete mailing address of known office of publication: 2200 Grand Avenue, Des Moines, Iowa 50312-5306. 5. Complete mailing address of the headquarters of general business offices of the publisher: 2200 Grand Avenue, Des Moines, Iowa 50312-5306. 6. Full names and complete mailing address of publisher, editor, and managing editor: Publisher and Editor: Donald B. Peschke, 2200 Grand Avenue, Des Moines, Iowa 50312; Managing Editor: Terry J. Strohmman, 2200 Grand Avenue, Des Moines, Iowa 50312. 7. Owner: Woodsmith Corporation, 2200 Grand Avenue, Des Moines, Iowa 50312; Donald B. Peschke, 2200 Grand Avenue, Des Moines, Iowa 50312. 8. Known bondholders, mortgagees, and other security holders owning 1 percent or more of total amount of bonds, mortgages or other securities: None. 9. (Does not apply.) 10. Extent and nature of circulation:

	Average no. copies each issue during preceding 12 months	Average no. copies of single issue published nearest to filing date
A. Total no. copies printed (net press run)	184,400	199,000
B. Paid and/or requested circulation:		
1. Sales through dealers, street vendors and counter sales	8,452	12,794
2. Mail subscriptions (paid and/or requested)	142,848	152,786
C. Total paid and/or requested circulation	151,280	165,580
D. Free distribution by mail, carrier or other means, samples, complimentary, and other free copies.	26	62
E. Total distribution	151,306	165,642
F. Copies not distributed		
1. Office use, left over, unaccounted, spoiled after printing	20,849	14,167
2. Returns from news agents	12,245	19,191
G. Total	184,400	199,000
11. I certify that the statements made by me above are correct and complete. (signed) Donald B. Peschke, Publisher/Editor		

Contents

Raised Panel Jig _____ **4**

Rout a perfect raised panel door or drawer using a router, a straight bit, and this shop-made jig.



Raised Panel Jig page 4

Block Plane Tips _____ **8**

From planing end and edge grain to trimming small pieces, here's a few tips that will provide crisp, clean cuts every time.

Sanding a Surface Flat _____ **10**

All it takes to produce a perfectly flat surface is a belt sander and four simple steps.

Rust Removal _____ **12**

Practical solutions for removing rust and restoring tools to a usable condition.

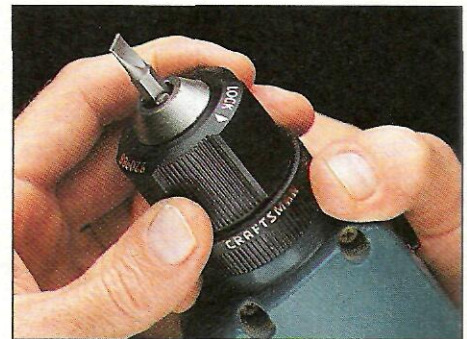

Keyless Chucks page 14

Keyless Chucks _____ **14**

Changing drill bits without a chuck key is quick and easy with this handy accessory for your portable drill.

Workbench _____ **16**

This workbench features a solid base that knocks down easily and a top that's built up of plywood and thin hardwood strips.

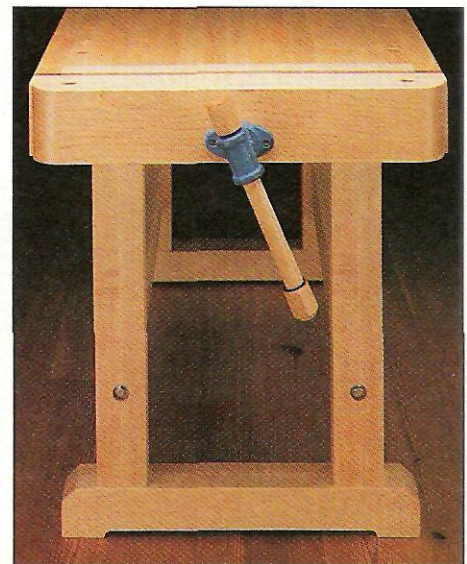

Workbench page 16

Shop-Made Vise _____ **23**

A massive wood face, iron guide rods, and a manufactured vise screw combine to provide even clamping pressure that holds a workpiece tight.

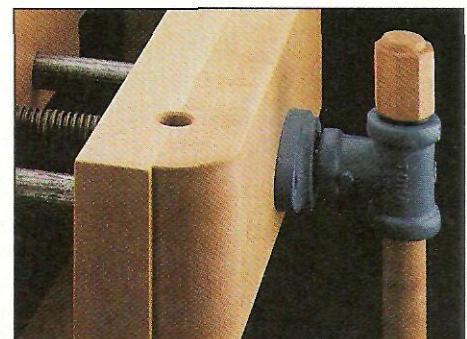

Shop-Made Vise page 23

Shop Solutions _____ **28**

Four shop-tested tips: Dowel Cutting Jig, Shop-Made Bench Clamp, Rip Fence Alignment Gauge, and a Glue Brush Tip.

Board Footage _____ **30**

Calculating board feet takes the guesswork out of determining the cost of a project.

Sources _____ **31**

Hardware, project supplies, and mail order sources for the projects in this issue.

Raised Panel Jig

All that's needed to make a raised panel is a router, an ordinary straight bit, and this simple jig.

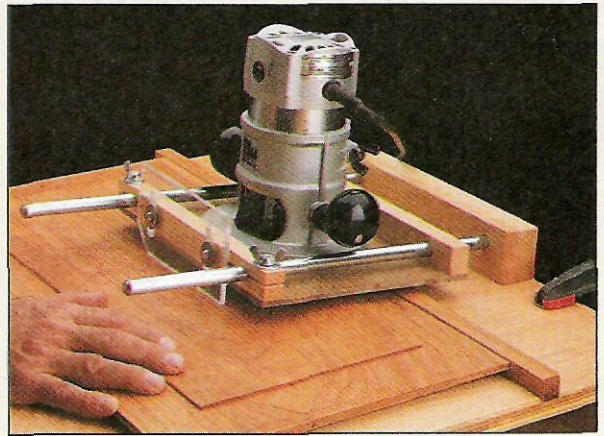

Sometimes a jig works out even better than expected. We originally designed this raised panel jig to rout square or rectangular pieces. But after working on it, we found that a simple modification allows you to rout *curved* raised panels as well. Regardless of the shape, the principle of the jig is the same. The router is held at an angle over the workpiece. Then the

panel is passed under the router. This creates an angled border around the edges of the panel that "raises" a field in the center.

BASE. I began work by making the plywood *base* (A), see Fig. 1. The base can be as big as you like. It just needs to be large enough to support the workpiece. (In my case, the base is 24" square.)

FENCE. Once the base is cut to size, a hardwood fence is installed. The *fence* (B) is screwed in a shallow dado in the base, see Fig. 1a. When routing a curved panel, the fence is replaced with a "pin." (For more on making curved raised panels, refer to page 7.)

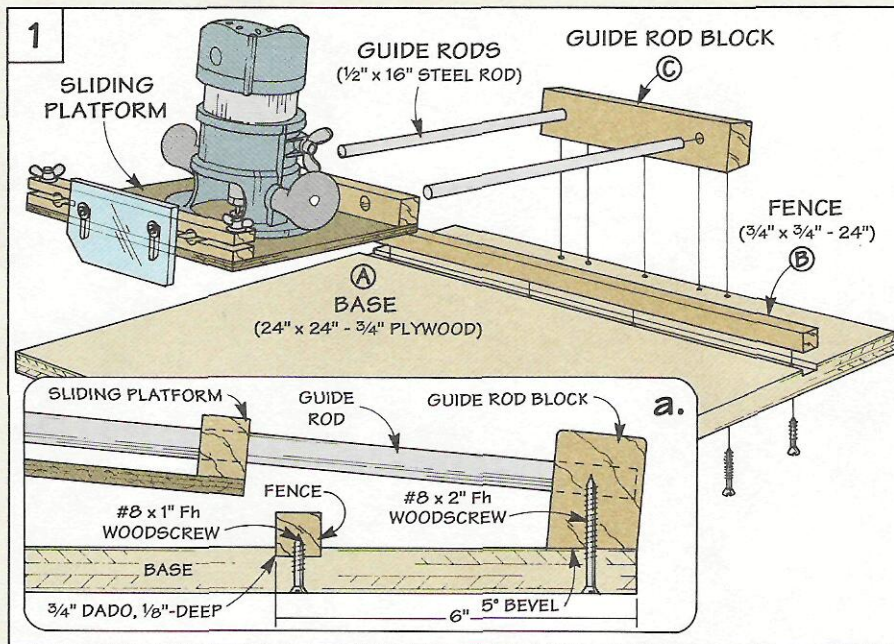

CARRIAGE ASSEMBLY

The heart of the jig is the carriage assembly. This assembly suspends the router at an angle over the workpiece. Since the router is tilted, an ordinary straight bit can be used to rout the angled border.

GUIDE RODS. The router is held at an angle by a pair of guide rods, see Fig. 1. These rods are 16" lengths of 1/2"-dia. steel rod that I bought at the hardware store. (There's also a source on page 31.)

GUIDE ROD BLOCK. The rods are supported by a *guide rod block* (C). This is two 3/4"-thick pieces of hardwood glued together, see Fig. 2. Then two holes are drilled to accept the ends of the guide rods.

The trick is to tilt the rods at a slight angle. This angle eventually determines the angle of the

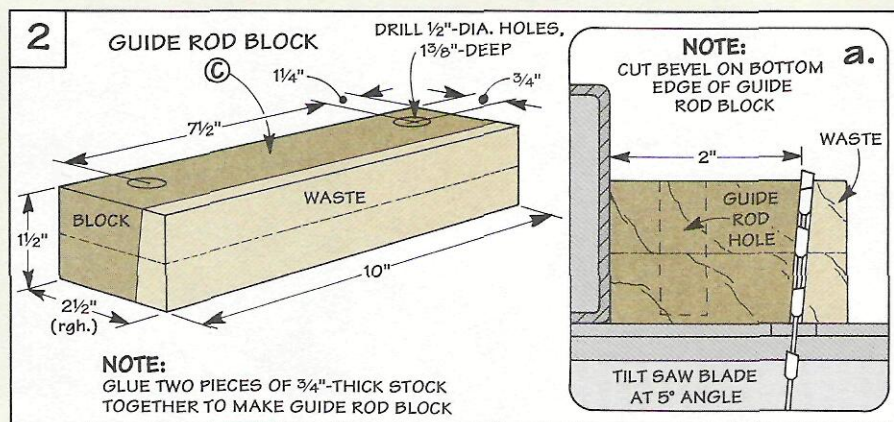

border on the raised panel. To create the angle, the bottom edge of the block is beveled before gluing and screwing it to the base, see Fig. 2a. Then the rods are epoxied in the holes.

SLIDING PLATFORM. With the rods in place, the next step is to add a sliding platform. The platform carries the router back and forth on the guide rods to increase the *width* of the border. It consists of three parts: a mounting plate, a pair of rails, and a finger guard, see Figs. 3 and 6.

MOUNTING PLATE. The *mounting plate (D)* is a piece of 1/4" Masonite that replaces the original base of the router, see Fig. 3. (I used the original base as a template to locate the mounting holes and the opening for the bit.)

RAILS. After marking and drilling the holes, a pair of hardwood rails (*E*) is added, see Fig. 3. Holes at each end of the rails fit over the guide rods and allow the platform to slide back and forth.

To keep the platform from binding, the holes need to align with the guide rods and with each other. To do this, I taped the rails together with double-sided tape and then centered the holes 7 1/2" apart, see Fig. 4. Note: Sand these holes lightly so the rails slide easily.

Before attaching the rails, there's one more thing to do. And that's to cut a kerf at each end of *one* rail, see Fig. 5a. Later, this

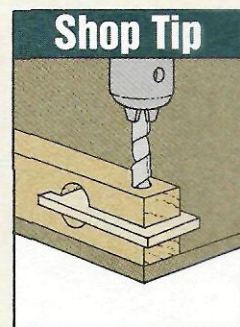
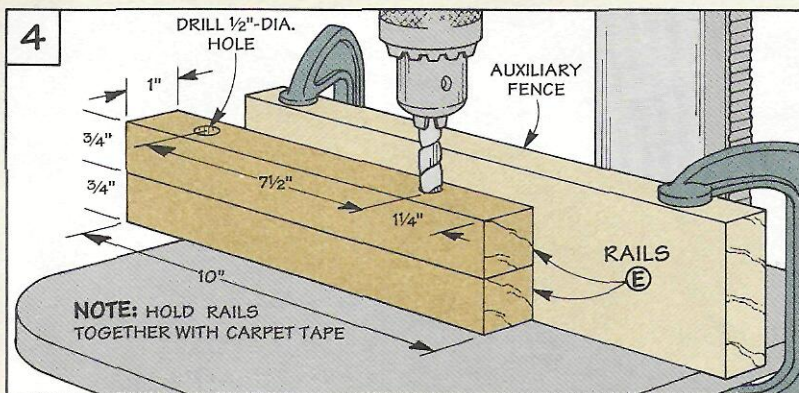
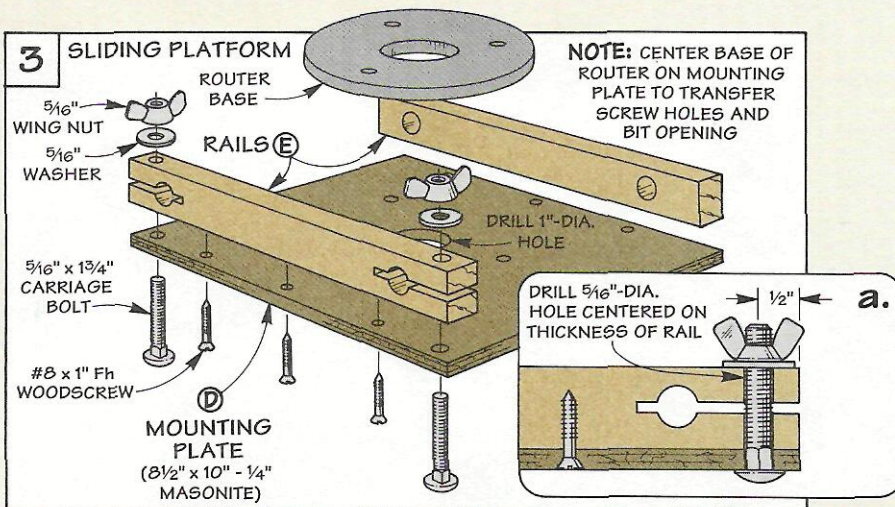

Shop Tip
Slip a thin piece of wood in the kerf to prevent the drill bit from binding.

rail acts as part of a clamping system that locks the platform in place. After cutting the kerfs, the rails are glued and screwed to the mounting plate, refer to Fig. 3.

CLAMP. Now the clamp can be completed. What makes the clamp work is two carriage bolts that pass through holes drilled in the ends of the kerfed rail, see Fig. 3a. By tightening wing nuts on

the bolts, the kerfed ends of the rail pinch against the guide rods and lock the platform in place.

FINGER GUARD. The last step is to add a finger guard. The guard is a piece of 1/4" plexiglas that's screwed *loosely* to the front rail, see Fig. 6. Two slots and a beveled bottom corner allow the guard to "ride up" on top of the workpiece as it's passed under the router.

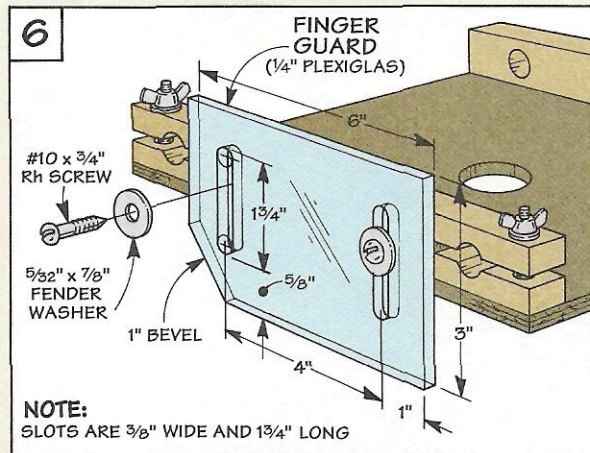
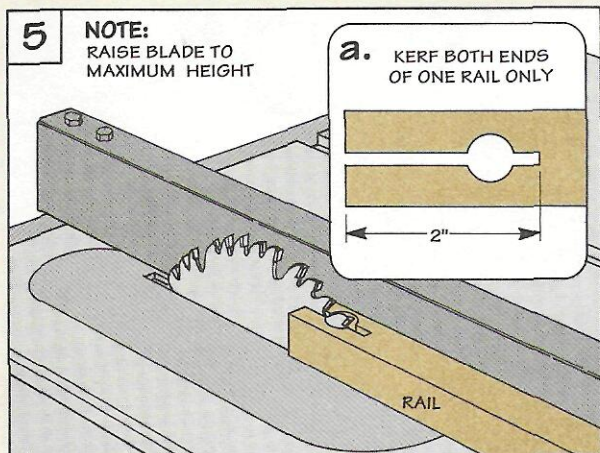

Hardware

- (2) 1/2" x 16" Steel Rods
- (5) #8 x 2" Fh Woodscrews
- (11) #8 x 1" Fh Woodscrews
- (2) 5/16" x 1 3/4" Carriage Bolts
- (2) 5/16" Flat Washers
- (2) 5/16" Wing Nuts
- (2) #10 x 3/4" Rh Screws
- (2) 5/32" x 7/8" Fender Washers

Making Raised Panels

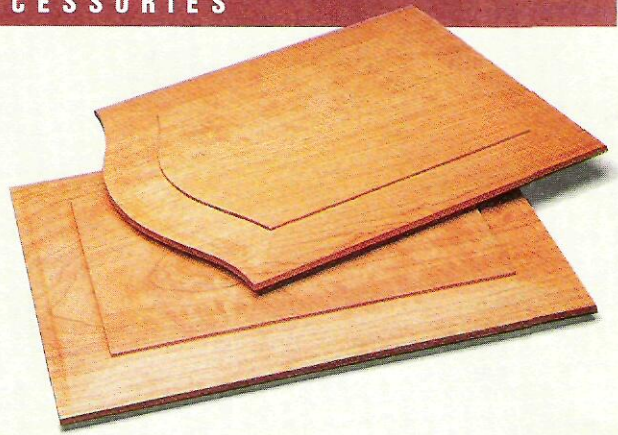

Routing an angled border around the edges of a panel creates a "raised" field in the center.

One way to turn an ordinary project into something special is with a raised panel door or drawer. Making these panels is simple using a router and the raised panel jig shown on page 4.

RABBET. Since most panels are surrounded by a frame, the first step is to fit the panel to the frame. This requires rabbeting the edges on both sides of the panel (I use a hand-held router), see Step 1. The

rabbets form a tongue that fits into a groove in the frame.

Before routing the angled border of the panel, there are two things to consider: grain direction and feed direction.

Raised Panels Step-by-Step

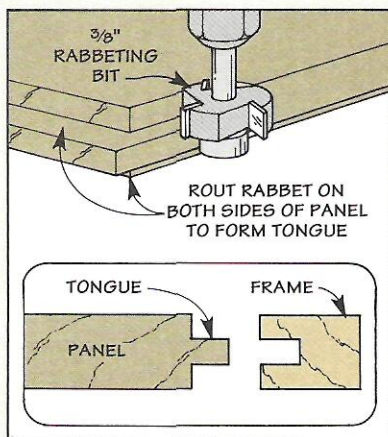

▲ **Step 1:** Using a 3/8" rabbeting bit, a rabbet is routed around the edges of the panel on both sides.

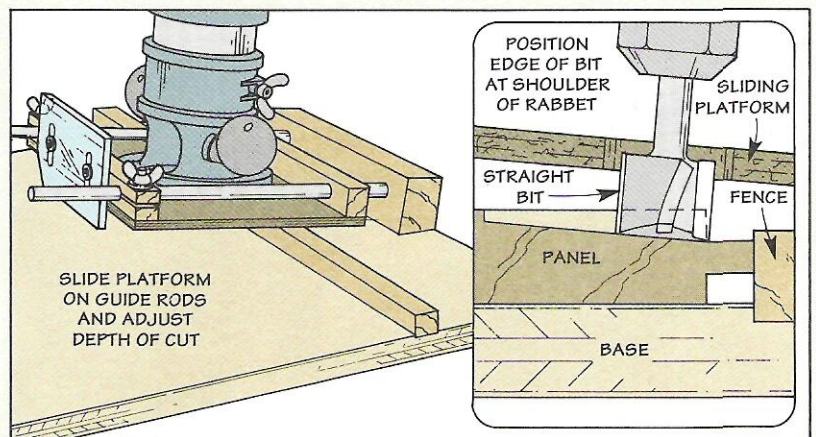

▲ **Step 2:** After mounting the router on the sliding platform, position the platform and adjust the

depth of cut so the edge of the bit is at the shoulder of the rabbet. Then clamp the platform in place.

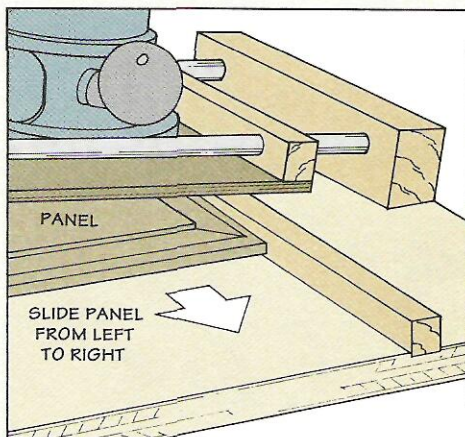

▲ **Step 3:** Make the first pass by sliding the panel from left to right. Then complete the border by

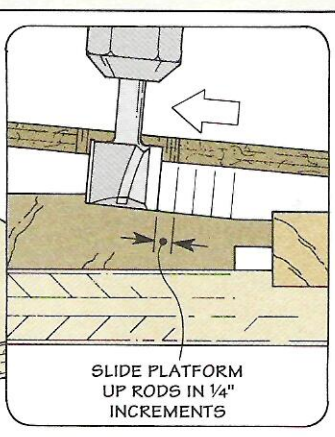

making a series of passes, moving the sliding platform in 1/4" increments between each pass.

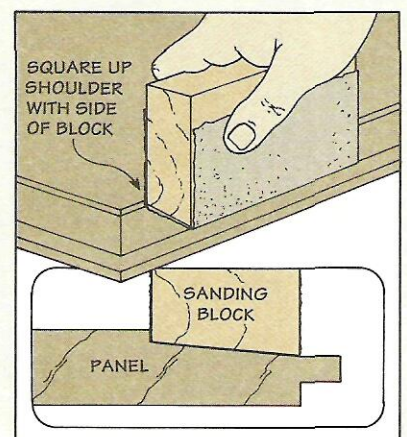

▲ **Step 4:** Now sand the border smooth and square up the shoulder with a beveled sanding block.

Curved Panels

GRAIN DIRECTION. To reduce the amount of chipout, the ends (or end grain) of the panel are routed first. Then, any chipout can be cleaned up by routing the sides (or edge grain).

FEED DIRECTION. Whether you're routing ends or sides, each pass is made by sliding the panel from *left to right*. This way, the clockwise rotation of the bit pulls the panel against the fence.

SET-UP. Now you're ready to "raise" the panel. After mounting the router to the sliding platform, the shoulder of the rabbet is used as a guide to set up the jig, see Step 2 on page 6.

WIDTH OF BORDER. When the first pass is completed around the entire panel, the *width* of the border can be increased. To do this, slide the platform up the guide rods, tighten the clamp, and make another pass around each edge. Then just repeat the process until the border is the desired width, see Step 3 on page 6.

CURVED RAISED PANELS

The beauty of this raised panel jig is it can also be used to rout *curved* panels.

RUB BLOCK. Since the curved edge doesn't conform to the straight line of the fence, the fence is replaced with a "rub block," see Step 1. (I used a short piece of $\frac{3}{4}$ "-dia. dowel.) The dowel is screwed in a hole that's centered on the dado in the base.

ROUT CURVED END. With the rub block in place, the curved end of the panel is routed in a series of passes. The idea is to pivot the panel slightly as you slide the edge against the rub block, see Step 2.

Ideally, you should end up with a consistent width across the entire border. If the width varies, just make additional passes until the border is a uniform width.

To complete the raised panel, replace the rub block with the fence and rout along the straight edges. The fi-

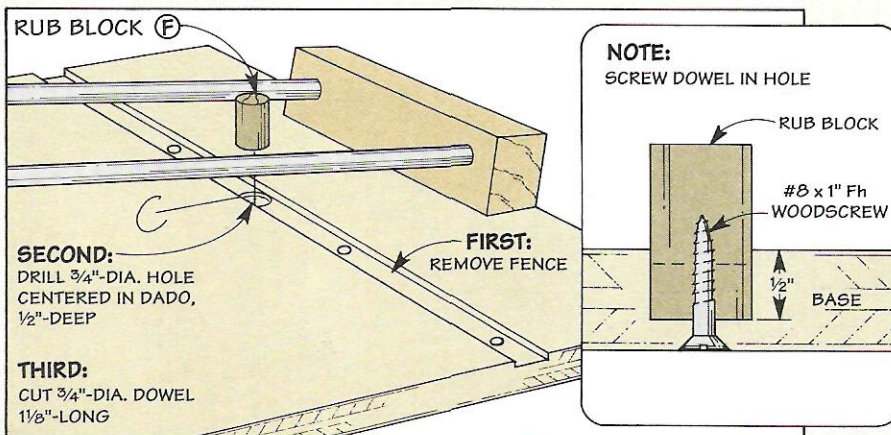

▲ **Step 1:** After removing the fence, install a short length of stopped hole that's centered on $\frac{3}{4}$ "-dia. dowel as a rub block. The dowel is screwed in a stopped hole that's centered on the dado in the base.

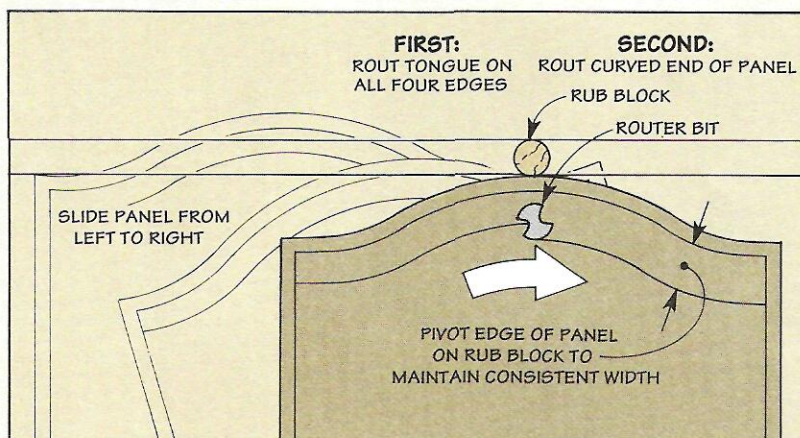

▲ **Step 2:** With the curved edge slightly. To ensure that the border of the panel riding against the rub block, pivot the workpiece is a consistent width, make an additional cleanup pass.

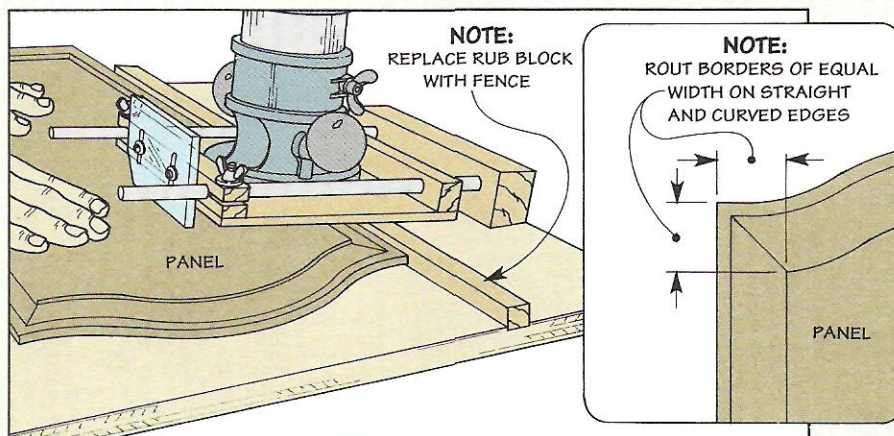

▲ **Step 3:** Complete the panel by replacing the fence and routing along the straight edges. The final pass should create a border the same width as the border on the curved end of the panel.

Block Plane Tips

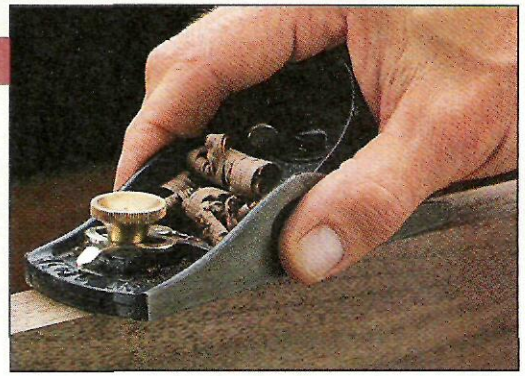

Although small in size, a block plane can tackle a large variety of wood-working tasks.

Many block planes spend much of their life sitting on a shelf. They're only called upon occasionally to plane some troublesome end grain. But I find myself using a block plane all the time. I use it for planing *both* end and edge grain, fitting joints, and trimming small pieces.

SMALL SIZE. One reason why I'm always reaching for my block plane has to do with its size. Most are small and light enough to slip comfortably into a tool pouch or apron pocket.

ONE-HAND. Their small size and light weight also makes the block plane very easy to use. In fact,

they're designed to be used with just one hand.

TECHNIQUE. As with any hand plane, you'll get better results with a block plane if you follow a few basic rules.

First, always keep the blade razor sharp. And take a *very* shallow cut with a tight throat opening, see drawing at right.

Second, to produce a shearing cut that slices the wood cleanly, it helps to skew the plane at an angle to the workpiece, see photo.

TIPS. In addition to these basic rules, there are a number of simple tips you can use to make a block plane do more for you.

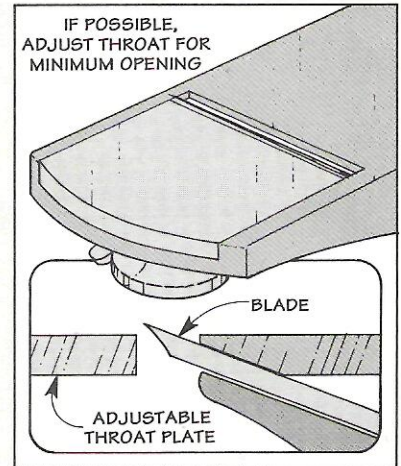

▲ To use a block plane, adjust the throat for the narrowest opening and take a very shallow cut.

Planing End Grain

■ Planing end grain presents a special problem. When a plane blade passes over the end of a workpiece, it can dig in and cause the end to break or chip off.

There are however, a couple of ways to prevent this.

TOWARD CENTER. One simple method is to plane from either

end of the workpiece toward the center, see Fig. 1. This avoids the problem by not allowing the blade to catch on the unsupported ends of the workpiece.

The only problem with doing this is it can be difficult to plane a straight edge that's both smooth and flat.

ADD SUPPORT. The solution I prefer is to clamp a scrap piece of wood to the end of the workpiece, see Fig. 2.

This way as you plane *toward* the scrap piece, the scrap piece supports the end fibers of the workpiece so they don't break or chip off.

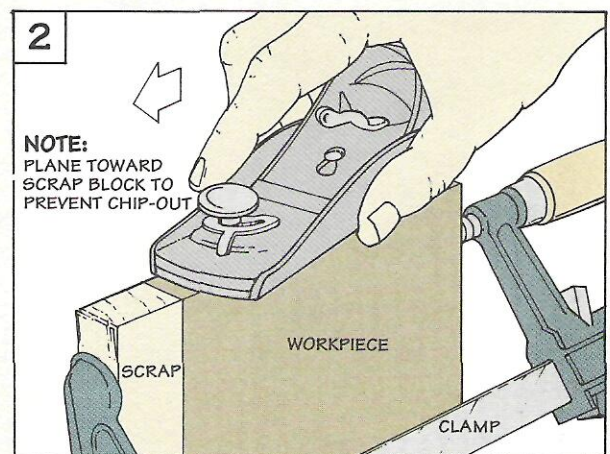
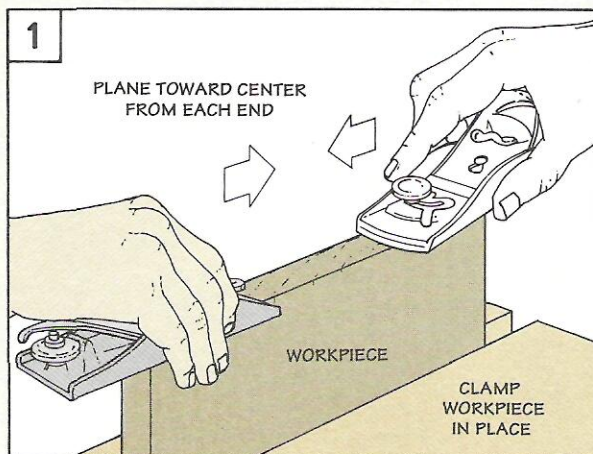

Squaring an Edge

Traditionally, block planes have been used for planing end grain. But they can also be used to square up the *edge* of a board. The idea is to stabilize the plane so it makes a cut that's 90° to the face of the workpiece.

FINGER FENCE. An easy way to do this is to wrap your fingers around the front of the plane and

pull it toward you, see Fig. 1. This allows your fingers to wrap around the plane and form a fence. Note: This method is quick, but it does take some practice.

WOOD FENCE. An almost fool-proof way to get a 90° edge is to make a wood fence and clamp it to the plane, see Fig. 2.

Note: For this to work, you'll

first need to make sure that the side of the plane is 90° to the sole.

The only problem with using a wood fence is the blade of the plane doesn't extend all the way to the edge of the plane body.

So to plane the entire edge of the workpiece, you'll need to cut a shallow rabbet in the face of the fence, see Fig. 2a.

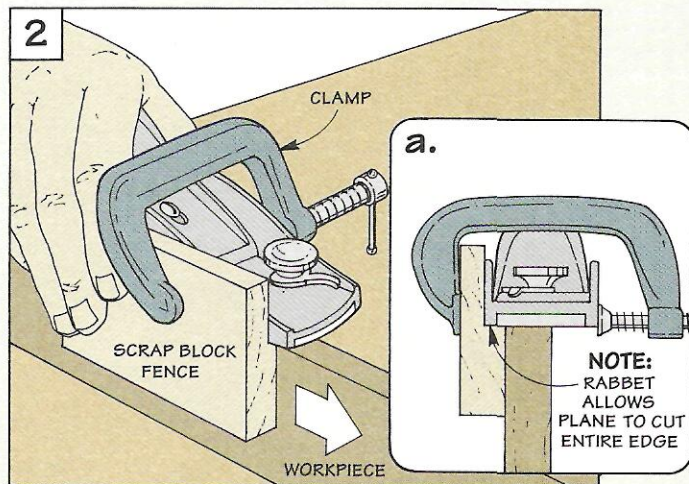
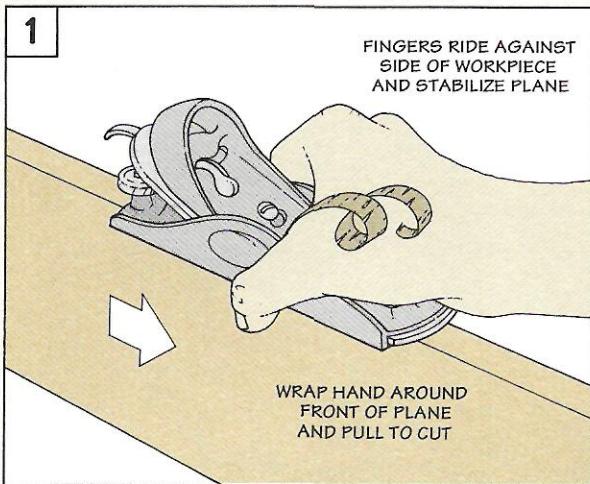

Trimming Small Pieces

Small workpieces (such as trim for a picture frame) have always been a challenge to plane. Besides being small, the trim is often routed with a decorative edge. And this makes them difficult to clamp in a vise.

Instead of trying to clamp the workpiece in a vise, I hold the

plane stationary and draw the *workpiece* over the blade to take a fine, controlled "paring" cut.

HOLD AGAINST BODY. One way to do this is to hold the plane in one hand tight against your body with the blade pointing away from you, see Fig. 1. Then holding the workpiece in your other hand,

draw it slowly over the blade.

"MINI" JOINTER. The other way to do this is to simply clamp the plane upside down in a vise.

This converts your block plane into a "mini" jointer, see Fig. 2. Then just push the workpiece slowly over the sole of the plane to trim it to size.

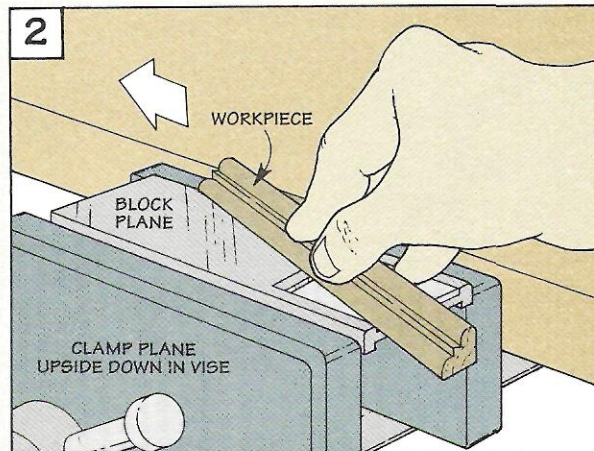
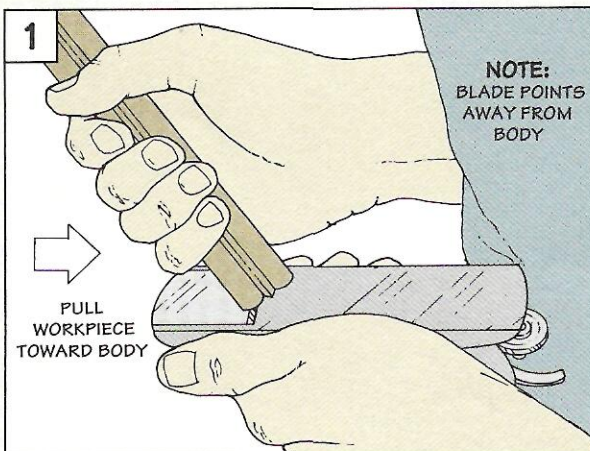



Sanding a Surface Flat

What's the quickest way to get a surface flat? Use a belt sander and this simple four-step process.

It happens to every woodworker. You're gluing up several pieces to make a table top or panel. Then as you apply the clamps, the pieces shift up and down. And no matter how hard you try, you end up with a workpiece that isn't flat.

One of the fastest and most effective ways I know to quickly flatten a glued-up top or panel is to use a belt sander.

LEVELING A SURFACE

Leveling a surface is a simple four step process. The first step is to mark the high spots with a pencil and a straight edge, refer to Step 1. Note: A light will help highlight the highs and lows.

REMOVE HIGHS. Now load an 80 grit belt on your sander and "knock off" the high spots, refer to Step 2. But don't sand with the grain. Instead, sand *across* the grain.

The first time someone saw me do this, they thought it was a mistake. But then I explained why it works so well.

Basically, the sander rides on *top* of the high spots and quickly grinds them down. If you sand with the grain, the sander rides on both the highs and lows. This results in a smooth surface — but it's not flat.

The secret is to keep the belt sander moving. If you don't, the sander can gouge the surface and

leave ridges and hollows. So keep it moving at all times.

COMFORT. In order to do this, you need to be as comfortable as possible. There are two reasons why this is important. First, leveling a surface takes time. If you're not comfortable, you may rush the job and ruin the surface.

And second, you won't be able to concentrate on controlling the sander. The trick to concentration is to remove as many distractions as possible.

DISTRACTIONS. The constant whine of a belt sander can be very distracting and even harmful. Hearing protectors solve the

problem and allow you to concentrate on the job at hand.

Belt sanders also create a lot of dust. A dust mask allows you to sand for a longer period of time and still breathe without choking.

Also, a belt sander cord has a nasty habit of getting in the way. To avoid this, just drape the cord over your shoulder, see Fig. 1.

BOTH HANDS. As you start to sand, use your hands and arms to guide the sander. Most belt sanders are heavy. They don't need any more downward pressure than the weight of the sander itself. The idea is to *hold back* on the sander, not push down.

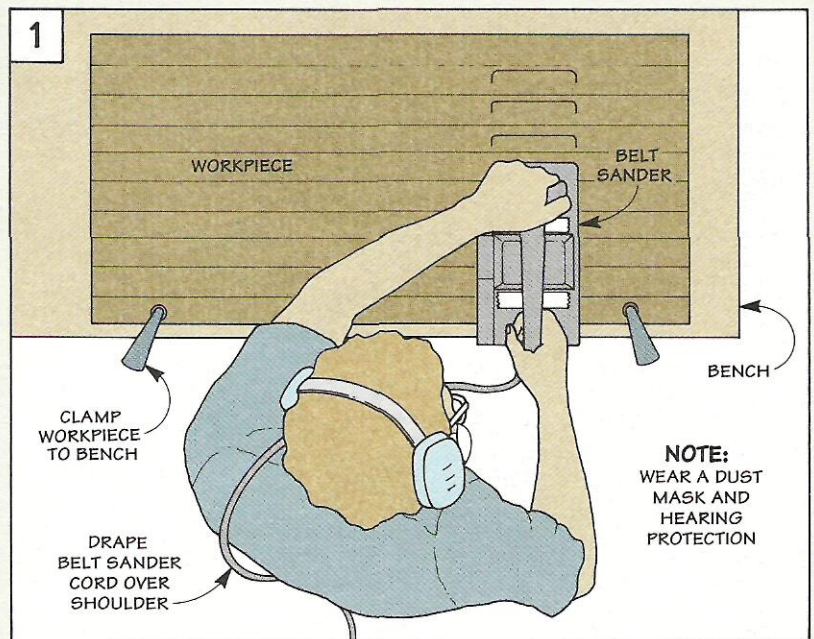

SAND ACROSS SURFACE. Now, sand the entire surface across the grain, refer to Step 3. Move the sander up and back at a slight angle — like a long, tall “W.”

In order to sand to the edge of the workpiece, you'll need to extend the sander *past* the edge. That's because the platen (the metal plate the belt rides on) is only four to five inches long — not the full length of the sander, see Fig 2.

The tricky part is knowing where this platen starts and stops. To give yourself a visual reference, try putting strips of tape on the top of the sander to mark the location of the platen, see Figs. 2 and 2a.

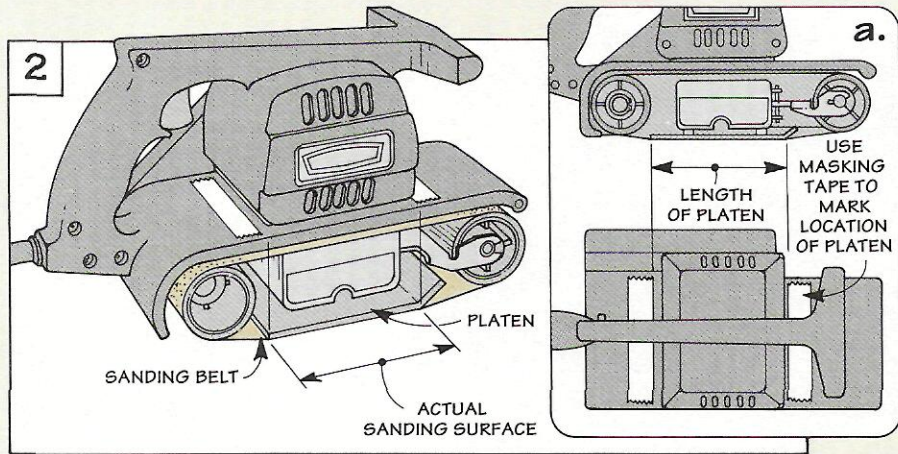

SAND WITH GRAIN. Now load on a fresh 80 grit belt and sand the entire surface with the grain, refer to Step 4. The goal is to remove the cross grain scratches.

When the scratches are gone, switch to a 120 grit belt and keep sanding. The idea is to leave finer scratches that can be removed with a finish sander or by hand.

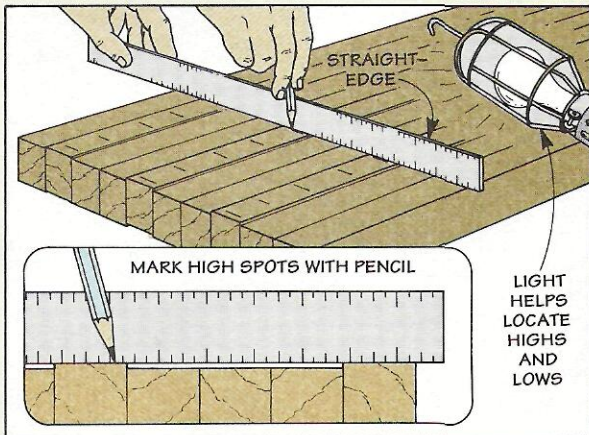

Step 1: Mark High Spots. Hold a straightedge across the workpiece. Then mark the high spots. Repeat every 2" for the length of the workpiece.

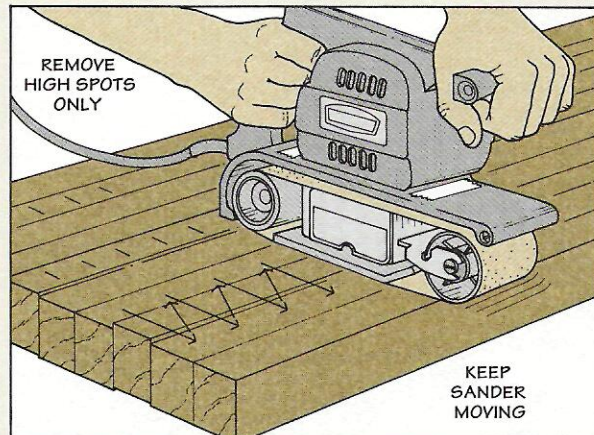

Step 2: Remove High Spots. Hold the sander 90° to the grain and gently move the sander back and forth over the marks. Don't stop in any one place.

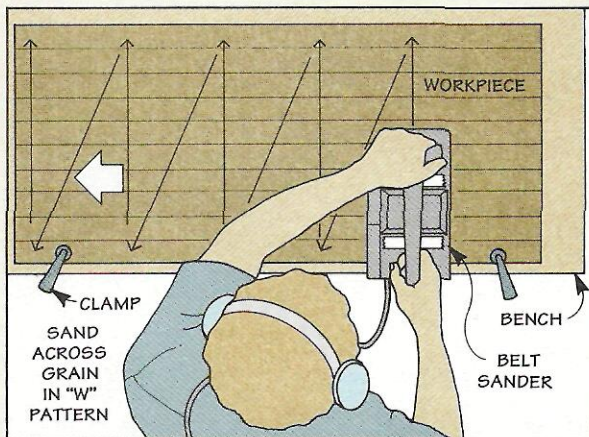

Step 3: Sand Across the Grain. Working right to left in a long “W” pattern, move sander forward (or backward) and slightly sideways at the same time.

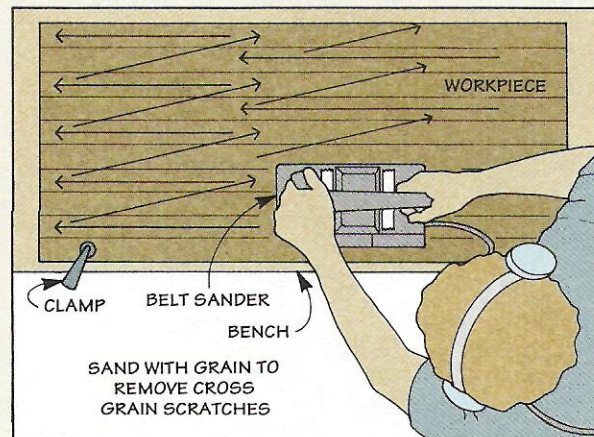

Step 4: Sand With the Grain. Switch to a finer grit sanding belt. Then remove all of the cross grain scratches by sanding with the grain.

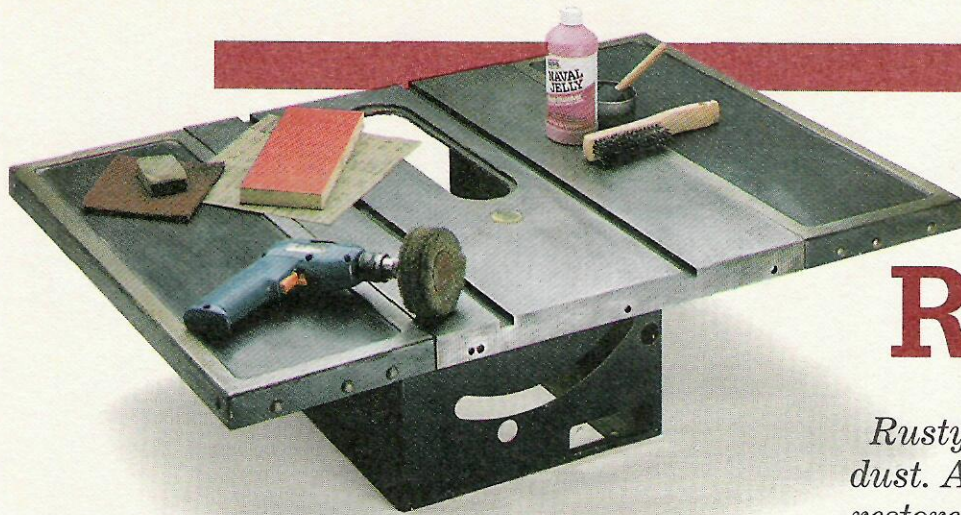

Rust Removal

Rusty tools don't need to gather dust. A few rust removal products restore them to a usable condition.

The deal of the decade. That's what a friend of mine thought when he bought a rusted table saw at a local farm auction. But after surveying the corroded top, I wasn't so sure.

To get a better look at the condition of the table, we removed the dirt and loose rust with a wire brush, see photo A. This revealed a coat of surface rust. And I suspected some pitting underneath.

Like many rusty tools, the table looked worse than it actually was. Still, restoring it to a usable condition would require a combination of chemical rust removers, abrasives, and some old-fashioned elbow grease.

CHEMICAL REMOVERS. We decided to try the easy way first — a chemical remover. A trip to the hardware store turned up *two* types of removers for dealing with rust. Some neutralized the

rust and dried to a paintable surface like the primer coat on a car. Others dissolved the rust.

RUST DISSOLVER. Not wanting to paint the top, we settled on a rust dissolver. One commonly available type is Naval Jelly. Although it looks like something you'd take for a queasy stomach, Naval Jelly is anything but medicinal.

The key ingredient is phosphoric acid which is carried in a pink slime. This solution is easy to apply. Just brush it on and let it sit for ten minutes. Note: Be sure to wear eye protection and rubber gloves.

Now comes the messy part — wiping it off with wet rags. This not only leaves a pile of dirty rags to dispose of, but the amount of rust removed is disappointing.

STRIPPING PAD. To speed up the process, I spread on another coat of Naval Jelly and worked it in with a coarse furniture strip-

ping pad, see Photo B. (I buy these pads at the local hardware store.)

The reason the pads work is because they're made of fibers that stick out like a shaggy beard. So in addition to hitting the high spots, they also work the chemical into the pitted areas to lift the rust out.

The combination of the pads and the Naval Jelly removed most of the rust. But the Naval Jelly left behind a protective coating that's a battleship gray color. Not the polished look you expect on a machined surface. To return it to its "original" polished surface, I sanded the top.

SANDING THE TOP. The key is to avoid creating an uneven surface by applying too much pressure in one place and not enough in another.

One way to do this is to use a shop-built surface sander, see photo C. The one I built is a piece

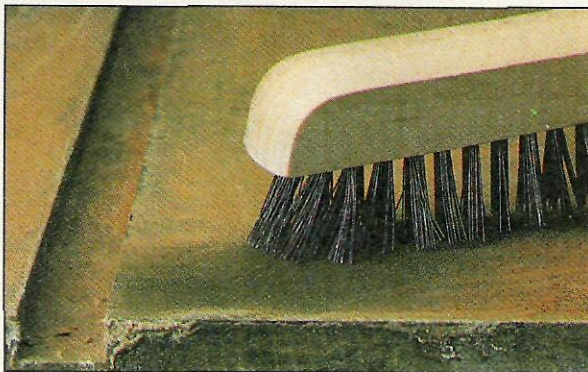

A. Remove Loose Rust. To get a better look at the condition of the top, a wire brush is used to remove most of the dirt and loose rust.



B. Rub in Chemical with Stripping Pad. A combination of a chemical dissolver like Naval Jelly and a furniture stripping pad removes the rest of the rust.

of particleboard with plastic laminate glued to the top and bottom to ensure a flat surface. A piece of Wet-or-Dry silicon carbide paper is glued to the laminate. Note: To make the paper easy to remove, I use a spray-on adhesive like 3M's Spray Mount.

To use the sander, start with a piece of 220 grit paper. Then spray on a lubricant (like WD-40) and sand in even strokes across the top. By using progressively finer grits, you can polish the top to a mirror surface.

PROTECTION

There's only one drawback. A shiny top is an open invitation to rust. And with the humidity here in Iowa, it can appear al-

most overnight. All it takes for a rusty haze to develop is two things: moisture and air.

To protect the top from rust, you need to seal moisture and

air away from the tool. This can be done in a couple of ways.

WAX. For years I've used ordinary floor wax. It's inexpensive and easy to apply. Just wipe on a thin layer of wax, let it dry, and buff it to a hard film.

SPRAY-ON COATINGS.

Recently I tried a spray-on coating. (I used Top-Cote, but there are several other products available.) It works by penetrating into the pores of the metal to seal out moisture.

Although it costs more than wax, Top-Cote is easier to apply. After spraying the surface, I found that it evaporates quickly and leaves a light gray film that's easy to buff out.

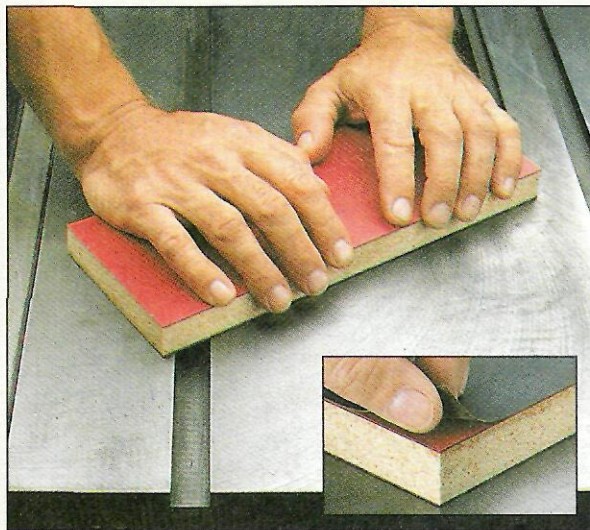

C. Sand the Top. Use a simple shop-built surface sander and a lubricant like WD-40 to restore the table top to its "original" polished surface.

New Products

There's nothing exciting about removing rust. But there are a couple of new products that can make the job a little easier.

WONDERBAR. One of them is the Wonderbar. (I found it while I was flipping through a tool catalog, see page 31 for sources.) This is a small block of rubber that you rub across a rusty surface like you'd erase a pencil mark.

What makes it work are small particles of silicon carbide that are embedded throughout the block. As the rubber wears away, new particles are exposed. So you're always working with a fresh abrasive surface.

GRITS. Wonderbars are available in fine, medium, and coarse grits. The fine grit can be used to polish tarnished surfaces like the sole of a plane, see photo above left. For heavy rust, the coarser grits are handy as "spot removers."

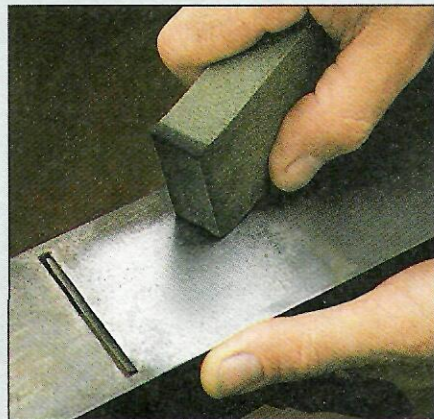

RIVET CLEANING DISC. Another product a friend at an auto parts supply house told me about is a rivet cleaning disc, see photo above right.

It's manufactured by the 3M Company to remove rust from around rivets without grinding down the head of the rivet. But this "soft" abrasive feature makes it a good rust removal tool for the shop as well.

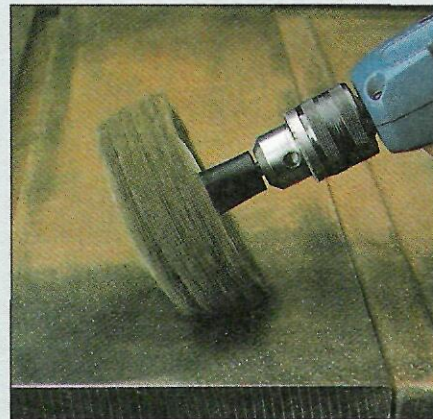

The rivet cleaner consists of a stack of flexible abrasive discs. The discs are held together with a spindle that threads onto an arbor. Note: The arbor is sold separately.

To use the rivet cleaner, just chuck the arbor in a hand-held drill. Even with the relatively slow speed of a portable drill, the disc removes heavy rust and leaves a polished surface behind.

Keyless Chucks

How can you change a drill bit without a key? Replace your old chuck with a keyless chuck.

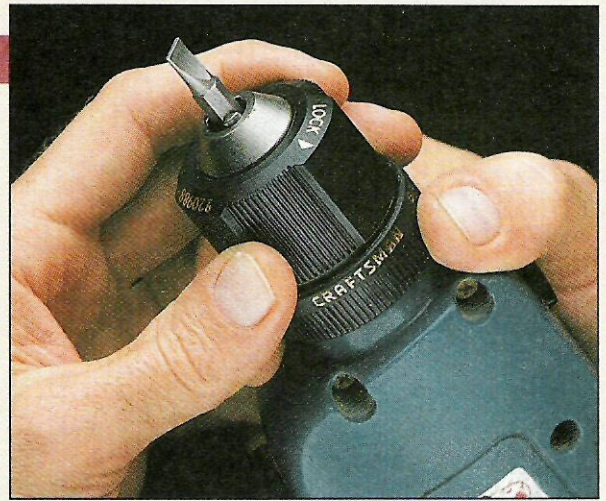

◀ **Jacobs:** One of the most common chucks on the market. It features ball bearing construction, and offers one of the best grips for changing bits.



◀ **Makita:** Although this chuck doesn't use ball bearing construction, it has one of the smoothest opening and closing actions of any of the chucks we tested.



◀ **Panasonic:** The most expensive of the chucks we tested, it has a unique ratchet system to help grip the bit. And it fully opens or closes in just four revolutions.



◀ **Sears:** The least expensive of the keyless chucks we shop-tested, this chuck offers ball bearing construction, and the best grip for changing bits.

Where's that chuck key? I set it down here somewhere... Sound familiar? Well, there's finally a solution to this — keyless chucks. Now you can replace your old drill chuck with a keyless chuck. And never have to search for your key again.

FOUR MODELS

We shop-tested four commonly available replacement chucks: Jacobs, Makita, Panasonic, and Sears, see photos at left. Prices ranged from a low of \$11.98 (Sears) to \$29.95 (Panasonic). (See page 31 for sources.)

The keyless chucks featured here will fit most 1/4" or 3/8" drills (both battery powered and electric) with a 3/8" - 10/24 thread.

(See the box on page 15 for replacement directions.) They're *not* designed for hammer drills or for use on a drill press.

WORK THE SAME. All of the chucks work basically the same way. You hold the base of the chuck with one hand, and spin the outer body of the chuck with the other, see photo above. This causes the jaws to move up or down to grip or release a bit. The amazing thing is a keyless chuck actually holds the bit *tighter* than a conventional chuck and key.

TEETH PER INCH

So how does a keyless chuck hold a bit so tight? The secret has to do with the threaded jaws inside the chuck, see Section View.

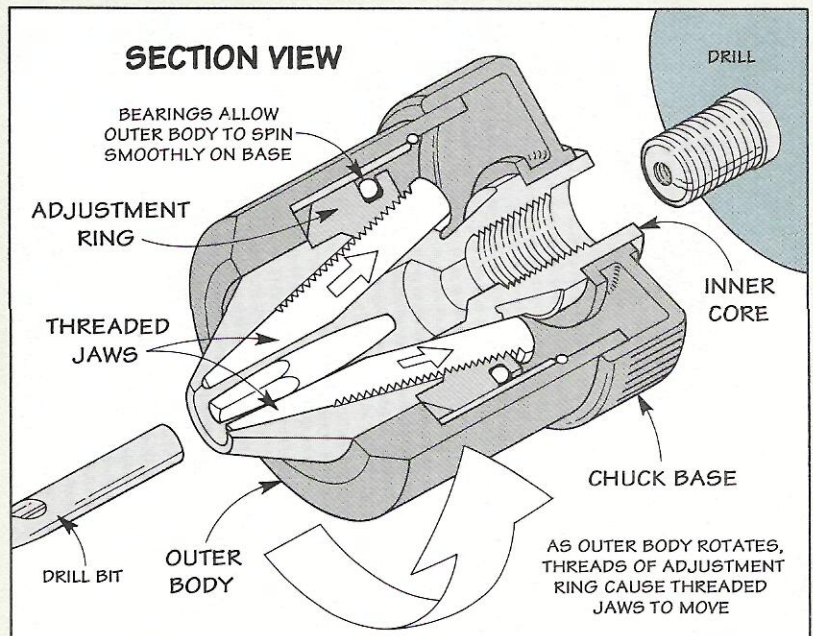

There are two sets of matching threads: one on the jaws, and the other set inside the adjustment ring, see Section View. As the chuck is turned, the threads on the ring engage those on the jaws causing them to open or close.

DOUBLE THE TEETH. The big difference is most keyless chucks have about *twice as many* teeth per inch than their keyed counterparts. Increasing the number of teeth like this gives you a mechanical advantage.

That is, a large movement (turning the chuck one full revolution) results in a small movement (the jaws move about 1/16"). In effect, you're mechanically increasing your own strength.

DIFFERENCES

All the chucks we tested were well made. But there were some differences in construction.

BALL BEARINGS. Two of the chucks (Jacobs and Sears) featured ball bearing construction. These chucks have a nice, smooth action as they're opened or closed.

RATCHET. The Panasonic however, is notably different — it fully opens or closes in fewer revolutions than the others (four com-

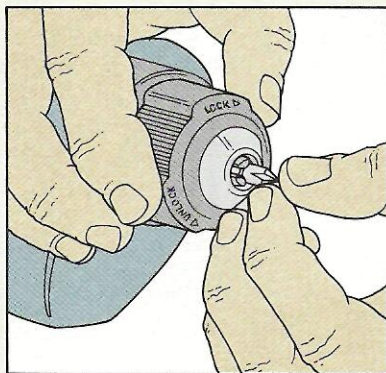

▲ One of the important differences between the chucks we tested is how far the jaws extend.

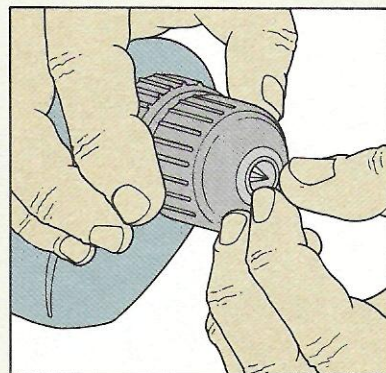

▲ On some models the jaws don't extend out enough to grip a short driver bit (or Vix bit).

pared with twenty). To do this they cut fewer threads on the jaws, not more.

Then to regain the mechanical advantage, they added a ratchet system that clicks as you turn it. (But we found the ratchet did too good of a job of holding the bit — we often had difficulty loosening the chuck to remove the bit.)

THE GRIP. One difference I noticed right away was the grip each chuck offered. The large outer bodies of the Jacobs and Sears provided the best grip. The Makita and Panasonic have a smaller base and outer body that I found difficult to grip.

JAW EXTENSION. Another difference was how far the jaws extend past the chuck. Three of the chucks (Makita, Sears, and Panasonic) were almost identical.

But the jaws on the Jacobs chuck were different. They didn't extend past the top of the chuck even when fully closed. This makes it difficult to use a short stubby bit, see drawings above.

RECOMMENDATION. As I said, all the chucks are well made. But for the money, you can't beat the Sears keyless chuck. It has an excellent grip, good jaw extension, ball bearing construction, and it's the least expensive.

Removing a Drill Chuck

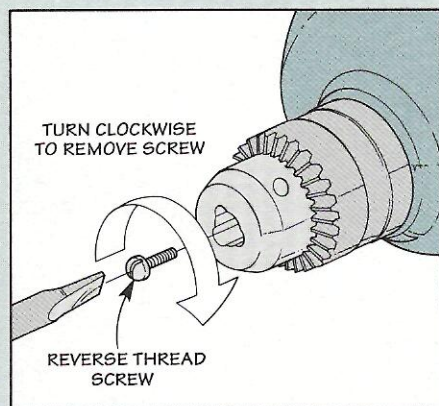

▲ To remove a chuck, unplug drill and open jaws. Then remove reverse thread screw by turning clockwise.

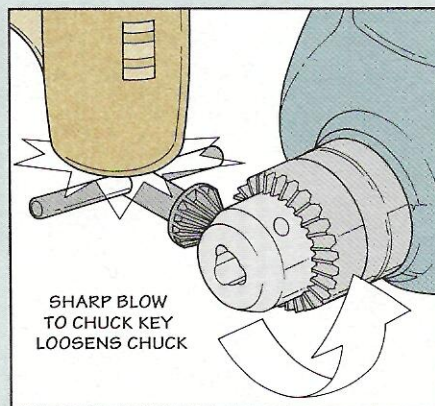

▲ The next step is to insert the chuck key. Rap it sharply with a hammer to loosen chuck. Then remove by hand.

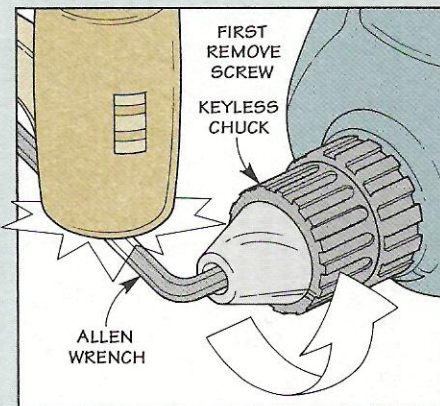

▲ To remove a keyless chuck, tighten an allen wrench in the jaws. Then rap the wrench with a hammer.

Workbench

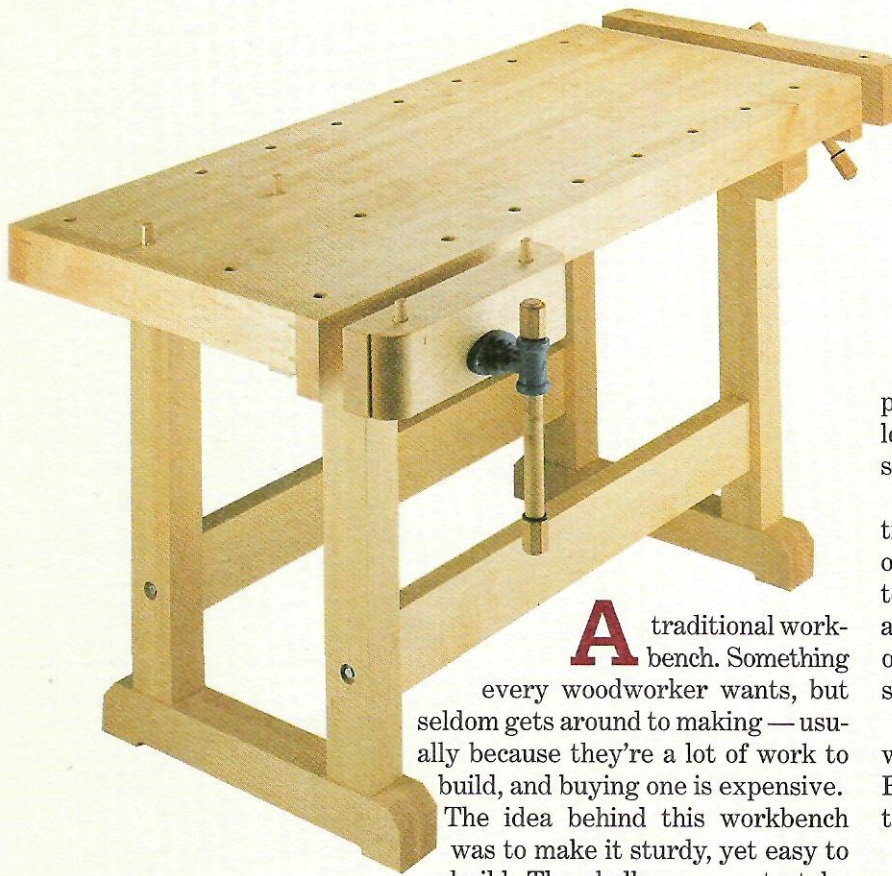

A traditional bench that's sturdy and easy to make. This workbench features a knock-down base and optional vises.

A traditional workbench. Something every woodworker wants, but seldom gets around to making — usually because they're a lot of work to build, and buying one is expensive. The idea behind this workbench was to make it sturdy, yet easy to build. The challenge was to take the three basic parts — the base, top, and vises, and come up with simple ways to build them.

THE BASE. On a traditional bench, the base is big and heavy. The weight is good. It helps create a stable foundation for the top. But the size can make the bench difficult to move or store. To solve this

problem, I used a unique shop-made system that lets you knock down the base into separate pieces, see photo A.

THE TOP. Just like the base, the tops on most traditional benches are glued up from large pieces of hardwood. Not only are these “slabs” a challenge to glue up, they're also difficult to get flat. So I took a different approach. I started with a double layer of plywood for strength. Then to get the same classic look, I glued on hardwood strips to the plywood.

To make the top even simpler, you can replace the wood strips with two layers of Masonite, see photo B. This way when the bench shows signs of wear, the top layer of Masonite can be easily replaced.

OPTIONS. You can use the bench without vises as a sturdy assembly table or work surface. Or you can add vises and make it more versatile. There are two ways to do this.

You could buy a metal woodworking vise and bolt it to the top. Or you can build one or two shop-made vises, see photo C. They're solid, inexpensive, and easy to make. (For more on this, see page 23.)

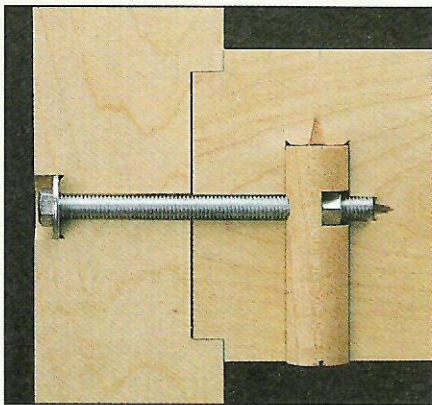

A. Knock-Down System: A nut captured in a cross dowel makes a simple but effective knock-down system.

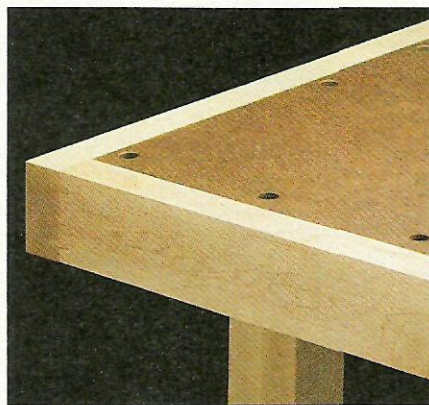

B. Replaceable Top: The top layer of Masonite is held in place with carpet tape so you can replace it.

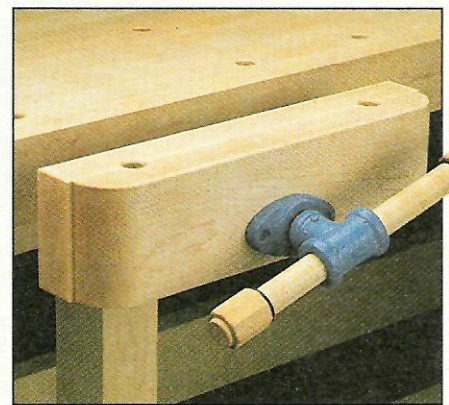

C. Optional Vise: A sturdy vise combined with a simple round dog system to make clamping a workpiece easy.

FEATURE PROJECT

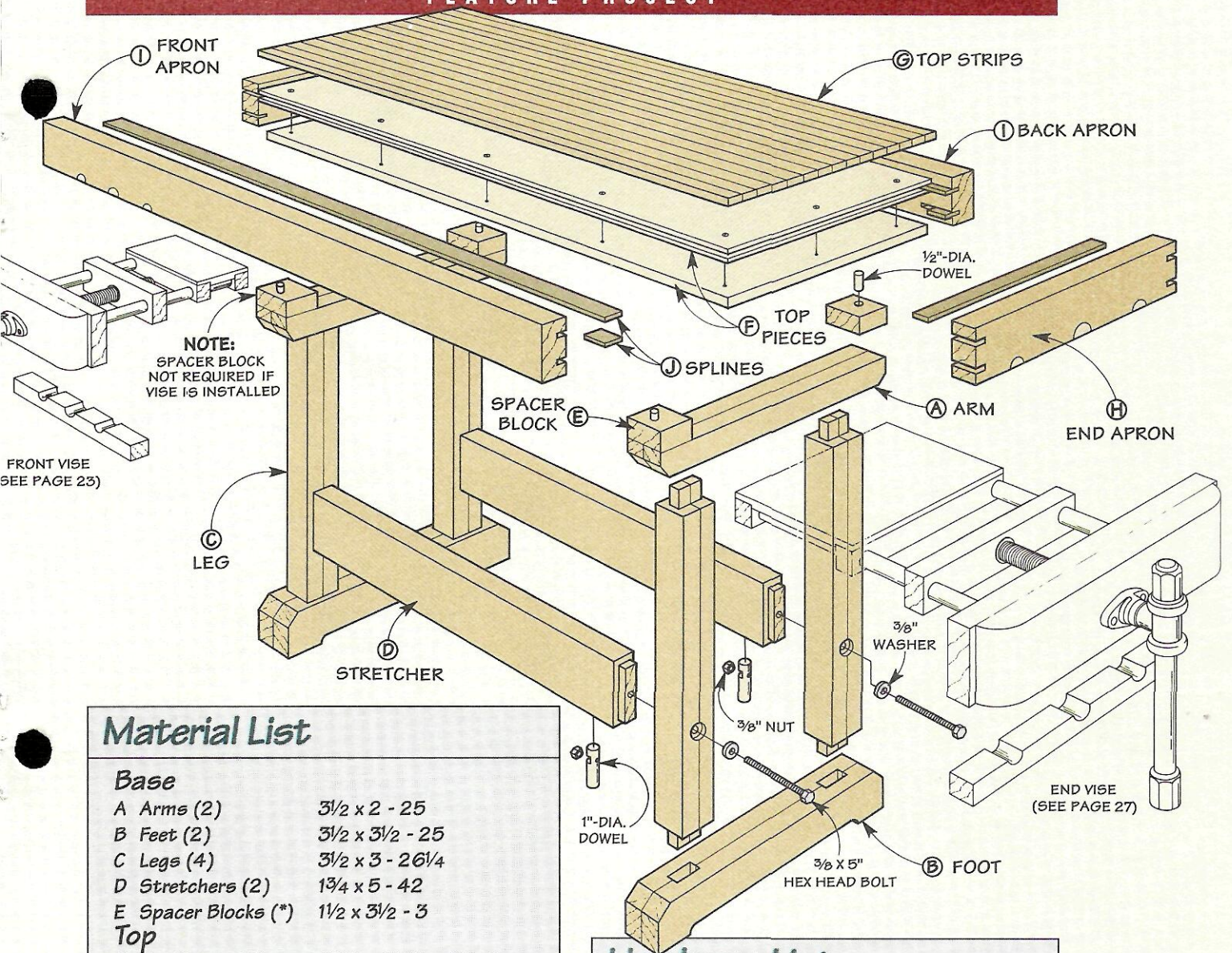

NOTE:
SPACER BLOCK
NOT REQUIRED IF
VISE IS INSTALLED

FRONT VISE
SEE PAGE 23)

END VISE
(SEE PAGE 27)

Material List

Base

A Arms (2)	3/2 x 2 - 25
B Feet (2)	3/2 x 3/2 - 25
C Legs (4)	3/2 x 3 - 26 1/4
D Stretchers (2)	1 3/4 x 5 - 42
E Spacer Blocks (*)	1 1/2 x 3/2 - 3

Top

F Top Pieces (2)	22 1/2 x 58 3/4 - 3/4 ply
G Top Strips (15)	1/2 x 1 1/2 - 59
H End Aprons (2)	1 3/4 x 3/2 - 22 1/2
I Fr./Bk. Aprons (2)	1 3/4 x 3/2 - 62 1/4
J Splines	1/4 x 1 - 16 Lineal Feet

* see text

Hardware List

- (15) No. 8 x 1 1/4" Fh Woodscrews
- (4) 3/8" Washers
- (4) 3/8" Nuts
- (4) 3/8" x 5" Hex Head Bolts
- (4) 1" x 3/2" Dowel
- (4) 1/2" x 1" Dowel

Cutting Diagram

1 3/4" x 8" - 96" (11 BD. FT.)

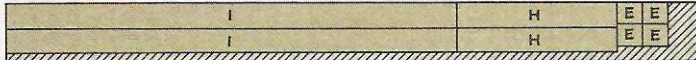

1 3/4" x 8" - 60" (7 BD. FT.)



1 3/4" x 10" - 96" (13 BD. FT.)



1 3/4" x 7" - 60" (6 BD. FT.)



1 3/4" x 6 1/2" - 96" (9 BD. FT.)



NOTE:
ALSO REQUIRED:
3/4" x 48" - 96" PLYWOOD

The Base

I began work on the bench by building the base. It consists of two side assemblies connected by a pair of stretchers, see Fig. 1.

SIDE ASSEMBLIES

Each side assembly is made up of an *arm* (A) that supports the bench top. And a *foot* (B) that rests on the floor. Then these two pieces are connected with two legs (C), see Fig. 1.

ARMS & FEET. Both the arms and the feet are made by gluing up two pieces of 8/4 (1 $\frac{3}{4}$ "-thick) stock. The length of both pieces is 25" — the only difference is their height (width), see Fig. 2. The arm is 2" high and the foot is 3 $\frac{1}{2}$ " high. To soften the corners of these pieces, I cut a bevel on each end, see Fig. 2a.

MORTISES. To make the side assemblies as strong as possible, the arms and feet are connected to the legs with mortise and tenon joints, see Fig. 1. The mortises in the arms and feet are the same size and same distance from each end, see Fig. 2a.

To make these mortises, I used a 1"-dia. Forstner bit in a drill press to remove most of the waste. Then I squared up the sides of the mortise with a chisel.

RELIEF. After cutting the mortises, a relief is cut in the bottom of each foot (B). An easy way to do this is to clamp the feet together and drill 1"-dia. holes for the start and stop points, see Fig. 3. Then, unclamp the feet and cut out the waste on the band saw.

LEGS. Now that you've completed the feet, the next step is to make the four *legs* (C). These pieces are glued up from 8/4 stock and are cut to a finished length of 26 $\frac{1}{4}$ ", see Fig. 4. (Note the location of the glue line.)

TENONS. After cutting the legs to length, tenons are cut on both ends. The tenons are 1 $\frac{1}{2}$ " long and sized to fit the mortises you

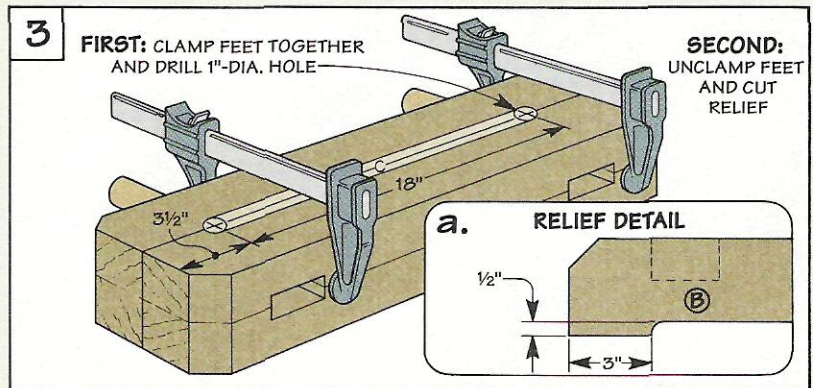
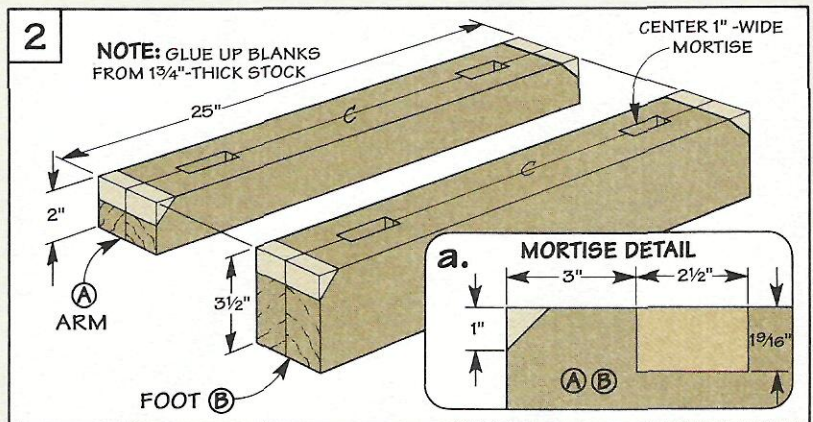
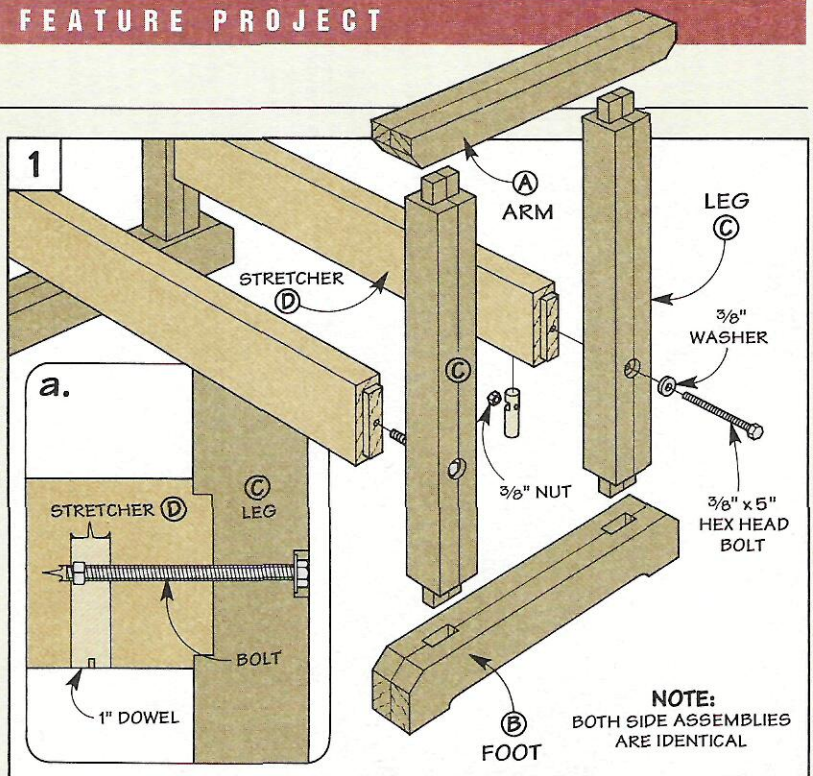

cut earlier in the arms and feet, see Figs. 4 and 4a.

Before gluing the legs in place, there are a couple more things to do. The first is to cut mortises for the stretchers that are added

later, see Figs. 4 and 4b. Second, you'll need to drill counterbored holes for connecting the stretchers to the legs, see Fig. 4b.

SIDE ASSEMBLY. Finally, sand all the sharp edges of the arms,

feet, and legs. Then glue up the two side assemblies.

STRETCHERS

The two *stretchers* (D) that connect the side assemblies are also made of 8/4 stock, see Fig. 5. Short tenons are cut on the ends to fit the mortises in the legs, see Fig. 5a.

KNOCK-DOWN SYSTEM. The secret to holding the stretchers in place is a unique knock-down system. It allows me to disassemble the base when I need to move or store it, refer to Figs. 1 and 1a. Then quickly assemble and tighten it to form a solid base again.

CROSS DOWEL. The heart of the knock-down system is a cross dowel that fits in the stretchers, see Fig. 5. A notch in the dowel "captures" a nut and prevents it from spinning when the bolt is tightened, refer to Photo A on page 16 and Fig. 7.

NOTCH. To locate this notch, dry clamp the base together and insert a 5"-long dowel in the stretcher, see Fig. 5a. Then drill a hole into the stretcher and through the dowel, see Fig. 6.

At the same time, make a mark on the dowel flush with the bottom of the stretcher (so you can cut it to length later), see Fig. 6.

CUT NOTCH. Now it's just a matter of cutting the notch, see Fig. 7a. To do this, I made two saw cuts, then cleaned out the waste with a chisel.

KERF DOWEL. Once the notch

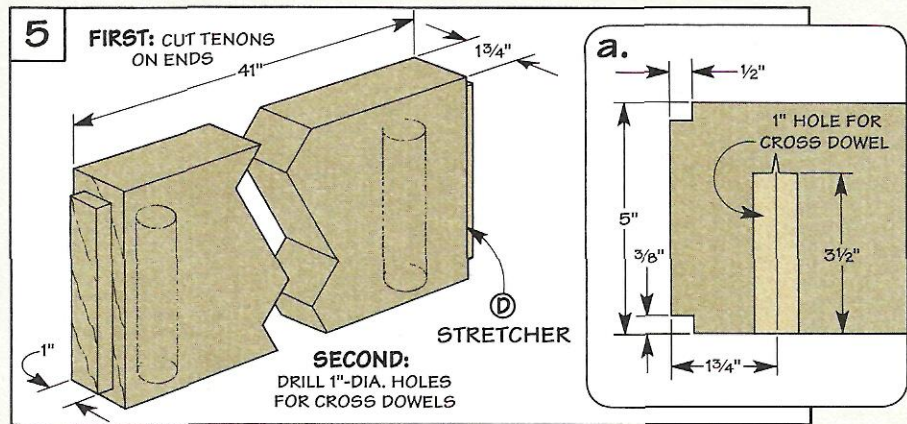
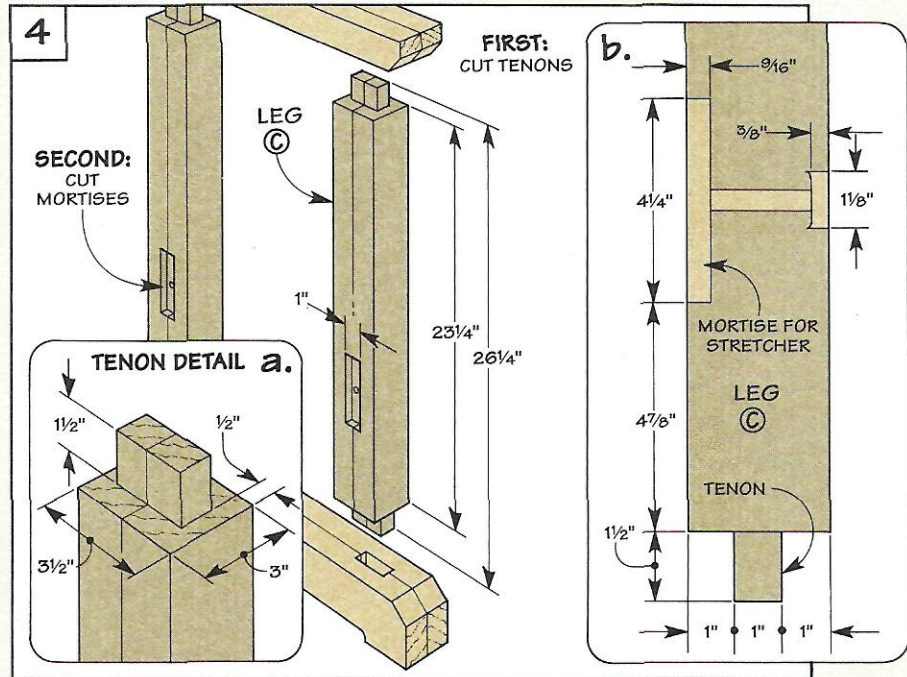

is made, cut the dowel to its finished length. Then, since it'll be difficult to rotate the dowel (and position the nut) after it's cut to length, I cut a slot in the bottom, see Fig. 7a. This way I can insert

a screwdriver in the slot and turn the dowel.

ASSEMBLY. Finally, assemble the base by first threading the bolts into the cross dowels. Then tighten down the bolts.

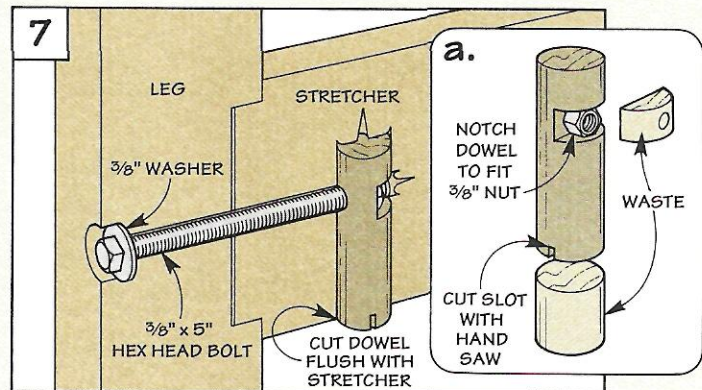
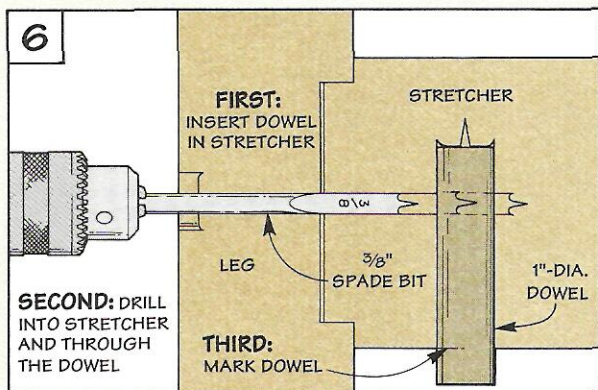

The Top

A sturdy, stable top is easy to make when you build it up from several layers.

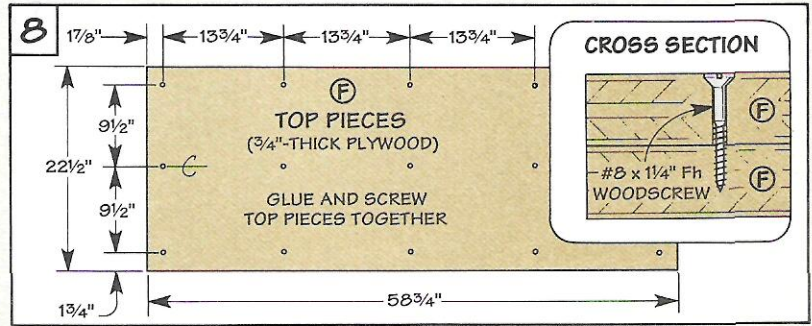
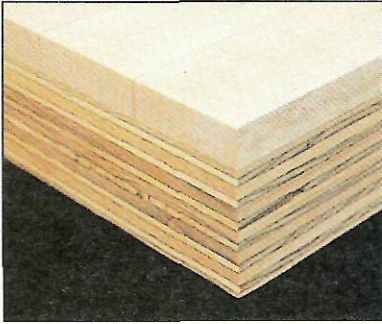

With the base complete, the next step is to build the top. It's built up by first gluing and screwing two plywood *top pieces* (F) together, see Fig. 8. Then, hardwood strips are glued to the plywood, see Fig. 9.

Note: Instead of hardwood strips, you can use a double layer of Masonite, see photo B on page 16. The first layer is screwed to the plywood. The second (top) layer is carpet-taped in place. This allows it to be replaced as needed.

STRIPS. To cut the *top strips* (G), start with a clear (no knots) blank of 1 1/2"-thick hardwood. Then cut 1/2"-thick strips off the *edge*, see Fig. 9a.

TEST FIT. To make sure all of the strips fit tight together, it's a good idea to test fit them *before* gluing them in place. Note: The strips are cut long so they hang over the ends, see Fig. 9.

ADHESIVE. After you've fit all the strips, the next step is to glue them to the top. The only unusual thing is the glue I used — construction adhesive (such as PL400).

I did this for two reasons. First, since the strips will move with seasonal changes in humidity, I needed an adhesive that was extremely strong, but still flexible. Second, to glue and position all the strips at once, I had to have an adhesive that had plenty of assembly time before it set up.

TRIM STRIPS. After letting the strips dry overnight, run a flush trim bit in a hand-held router around the top, see Fig. 11.

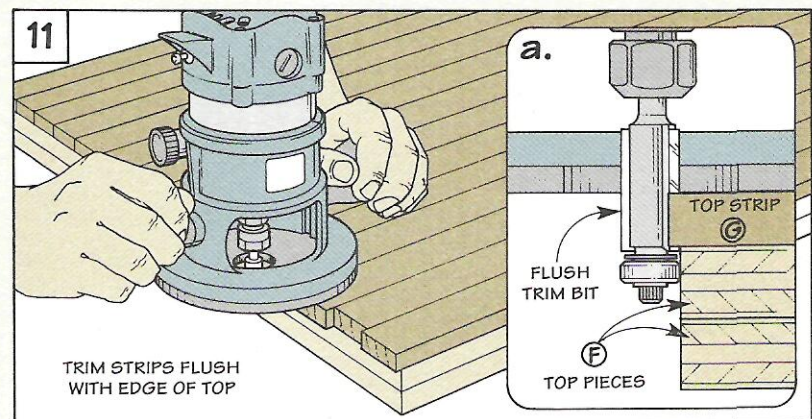
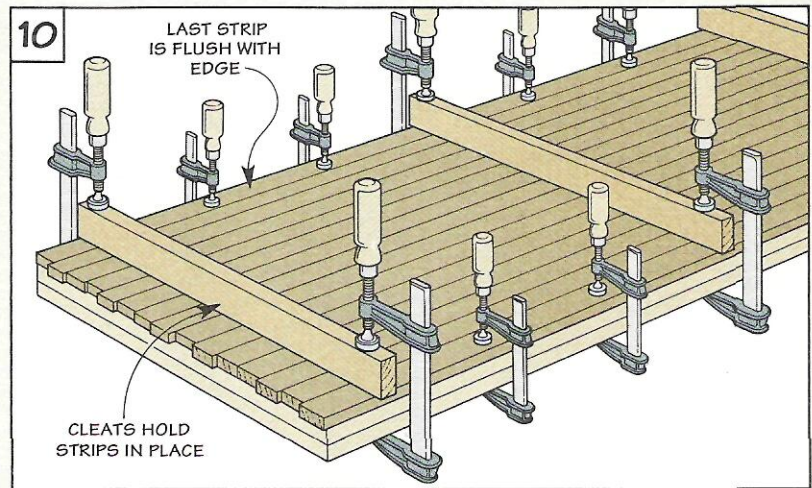
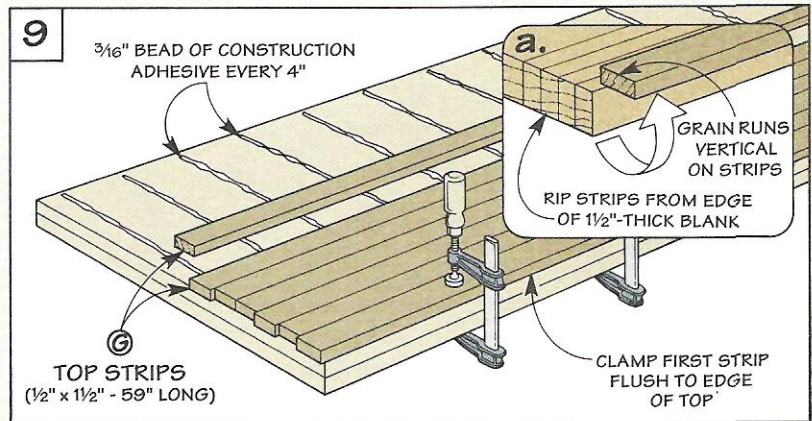

The Aprons

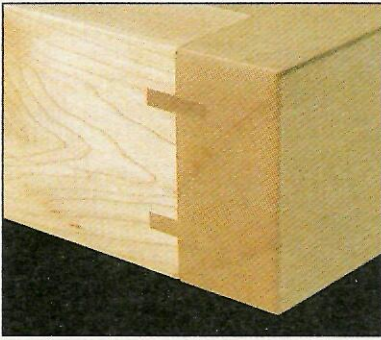

▲ The aprons are attached to the top with a spline and groove joint. These splines also lock the corners of the aprons together.

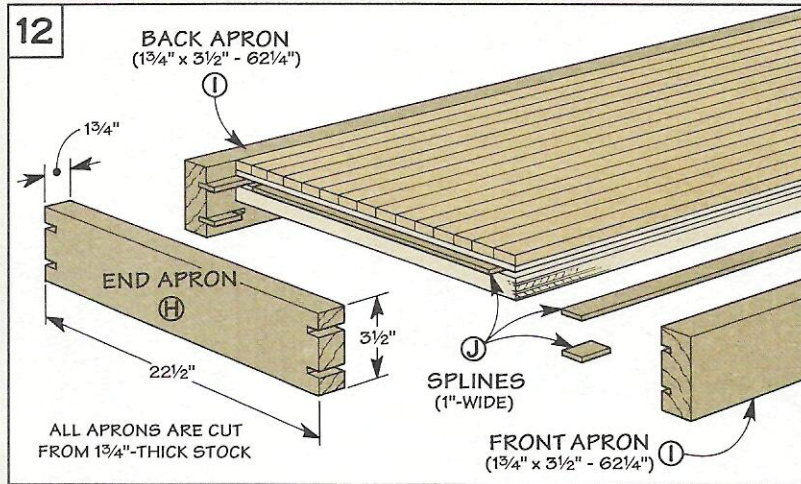

All that's left to complete the top is to add the aprons, see Fig. 12. The aprons wrap around the top and cover the plywood edges. They also form the back jaw of the shop-made vises on page 23.

CUT APRONS. All of the aprons are cut from 1 3/4"-thick stock and are 3 1/2" wide. The *end aprons (H)* are cut to match the width of the top (22 1/2"). The *front and back aprons (I)* are cut to match the length of the top *plus* the thickness of the two end aprons (62 1/4").

SPLINE & GROOVE. To join the aprons to the top, and to "lock" the corners of the aprons together, I used a spline and groove joint, see Fig. 12.

GROOVES. The first step to making this joint is to rout a groove around the edge of the top, see Figs. 13 and 13a.

Then a matching groove is routed on the inside face of the apron pieces (H,I). Note: To lock the top corners of the aprons together, this groove "wraps around" the top ends of the end aprons (H), see Fig. 14.

To lock the bottom corner of the aprons together, I routed another groove across the lower ends of the end aprons (H), see Fig. 14. Then a matching stopped groove is routed near the bottom edge of the front and back aprons (I), see Fig. 15.

SPLINES. After the grooves are routed, 1"-wide hardwood *splines (J)* are cut to fit in the grooves, see Figs. 14 and 15.

Before gluing the splines and aprons to the top, there are a couple of things to consider. First, if you're adding one (or two) of the

shop-made vises shown on page 23, the aprons need to be drilled before they're glued to the top.

Second, if you have a Masonite top, lift off the top layer before gluing on the aprons. If you don't, the top layer will be glued to the aprons and won't be removable.

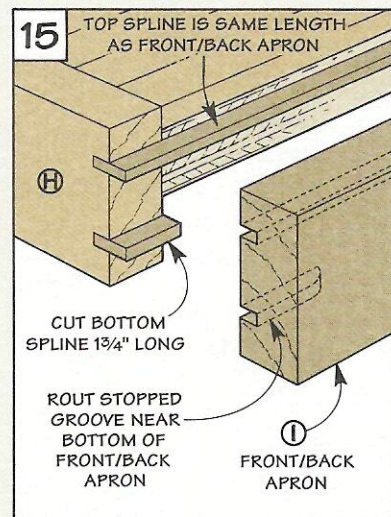
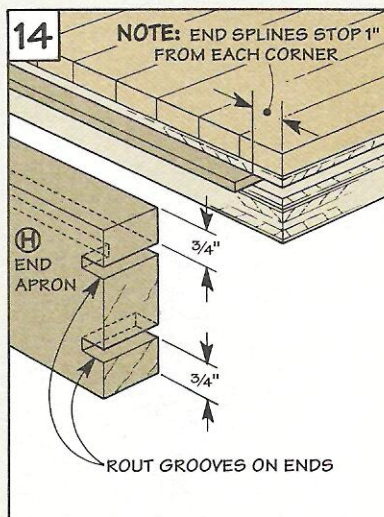
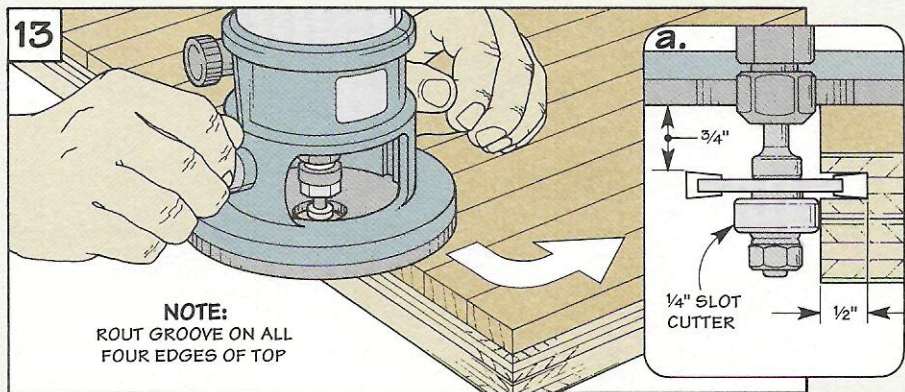

Assembly

With the top complete, there's one more step before assembling the bench. That's to glue spacer blocks to the arms of the base, see Fig. 16.

SPACER BLOCKS. The spacer blocks allow you to adjust the working height of the bench. At the same time, they provide clearance for the vises shown on page 23. In my case, the blocks are 1½"-high (thick). This makes the working height of the bench 34".

You'll need four *spacer blocks* (E) (three if you've installed the shop-made front vise), see Fig. 16. After you've cut the blocks to size, glue them to the top of the arms.

DOWEL PINS. The top is held to the base with four dowel pins. These pins fit in holes drilled in the front and back aprons (I) and in the spacer blocks (E).

Locating the holes in the aprons is easy. Start by flipping the top upside down. Then drill ½"-dia. holes, 9" in from each end of the front and back aprons, see Figs. 17 and 17a.

To locate the matching holes in the spacer blocks, I used dowel centers, see Fig. 17a. (These are just round metal inserts with sharp points. They're available at most hardware stores.)

DOWEL CENTER. Insert a dowel center in each apron hole. Then flip the base upside down and position it so it's centered from end-to-end and from front-to-back. To transfer the hole locations, simply tap on the base.

Then flip the base right side up and drill the holes. Next, insert the dowel pins and set the top on the base, see Fig. 18.

FINISH. The only thing left is to apply a finish to the bench. I wanted a finish that was durable *and* easy to maintain. Polyurethane is durable, but it can crack under heavy use. So I went with an oil finish. I rubbed in two coats of tung oil. Then buffed the bench to a nice sheen.

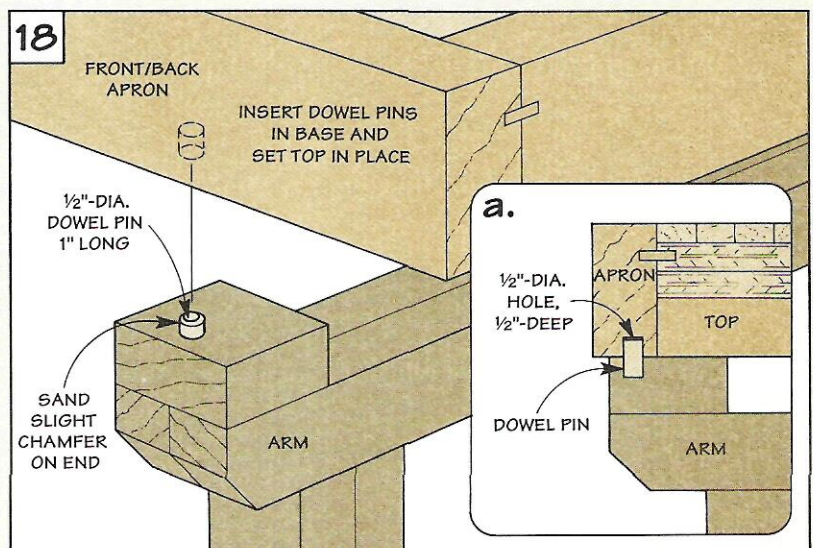
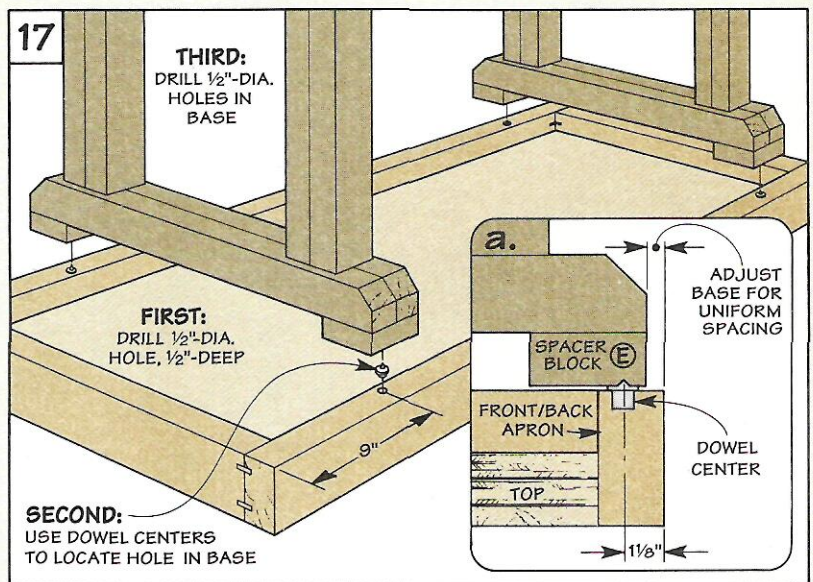
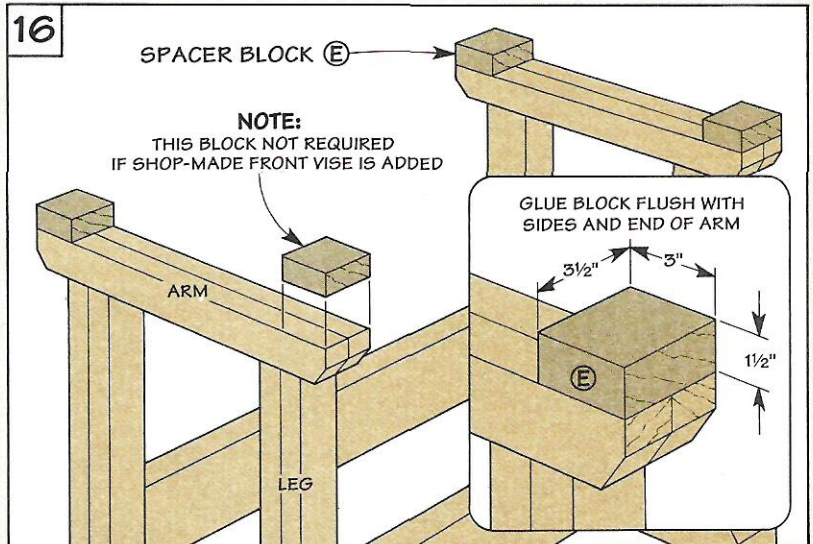

Shop-Made Vise

This vise combines a massive wood face and a double row of dog holes to provide two separate clamping options.

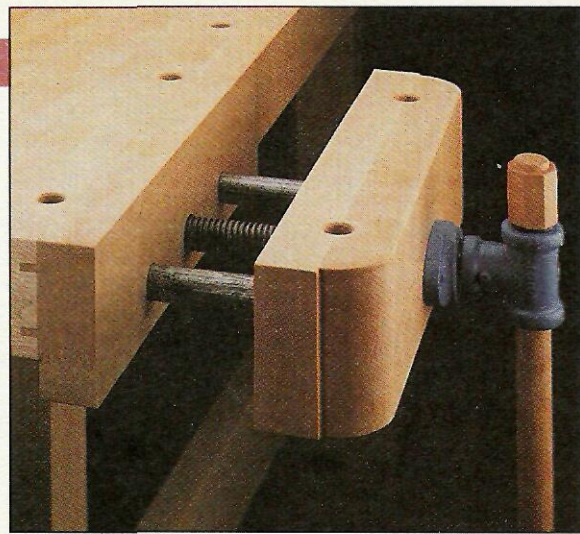

If there's one feature that changes a workbench from a simple table into a real woodworking tool, it's a vise. So when we set about building the bench in this issue, the question naturally came up about the kind of vise it should have.

After looking at several manufactured vises, it was obvious that an inexpensive vise with all the features we wanted just wasn't available. That's when we decided to build our own shop-made version, see photo.

CLAMPING OPTIONS. This vise provides two different clamping options. A massive wood face clamps work against the front of the bench. And there are two rows of dog holes (with shop-made dogs to go with them) that allow large projects to

be clamped on the benchtop.

TWO VISES. To make the bench more versatile, I added a second vise to the other end. (For information on building this vise, refer to page 27.) Although both vises are designed to complement the *ShopNotes* bench, with a few modifications either of them can be added to an existing workbench.

MATERIALS. All it takes is a vise screw and a few basic materials. The main component is a 21¼"-long vise screw that I bought from a tool catalog. (See page 31 for sources of hardware.)

The metal rods that guide the face of the vise are cut from sections of black iron pipe that I picked up at the hardware store. And the wood parts of the vise are made from 84 (1¾"-thick) hard maple.

EXPLODED VIEW

Hardware

- (1) 1½" - dia. x 21¼" Vise Screw
- (2) ¼" x 4½" Lag Screws
- (6) ¼" x 3" Lag Screws
- (6) #12 x 1½" Fh Screws
- (6) #8 x 1¼" Fh Screws
- (4) 2" Concrete Nails
- (4) 3" Concrete Nails
- (2) ¾" I.D. x 24" Iron Pipe
- (8) ¼" Flat Washers
- (2) #6 x ¾" Fh Wood-screws (Brass)
- (6) #10 x 2½" Fh Screws
- (2) 1"-dia. O-Rings

Materials List

A	Keeper Strip (1)	1¾" x 1½" - 18"
B	Face (two pieces)	1¾" x 5" - 18" (rgh.)
C	Guide Block (1)	1¾" x 3" - 10½"
D	Brace Blocks (2)	1¾" x 2¾" (rgh.) - 10½"
E	Brace Plate (1)	7 x 10½" - ¾" plywood
F	Spacer Blocks (2)	1¾" x 3" - 2¼"
G	Guide Rails (2)	1½" x 2" - 22½"
H	Handle (1)	1"-dia. Dowel - 14"
I	Cap (2)	1½" x 1½" - 1½"

Note: Parts cut from (1) 1¾" x 5½" - 96"-long piece.

Front Vise

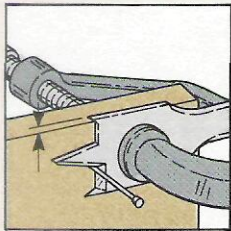
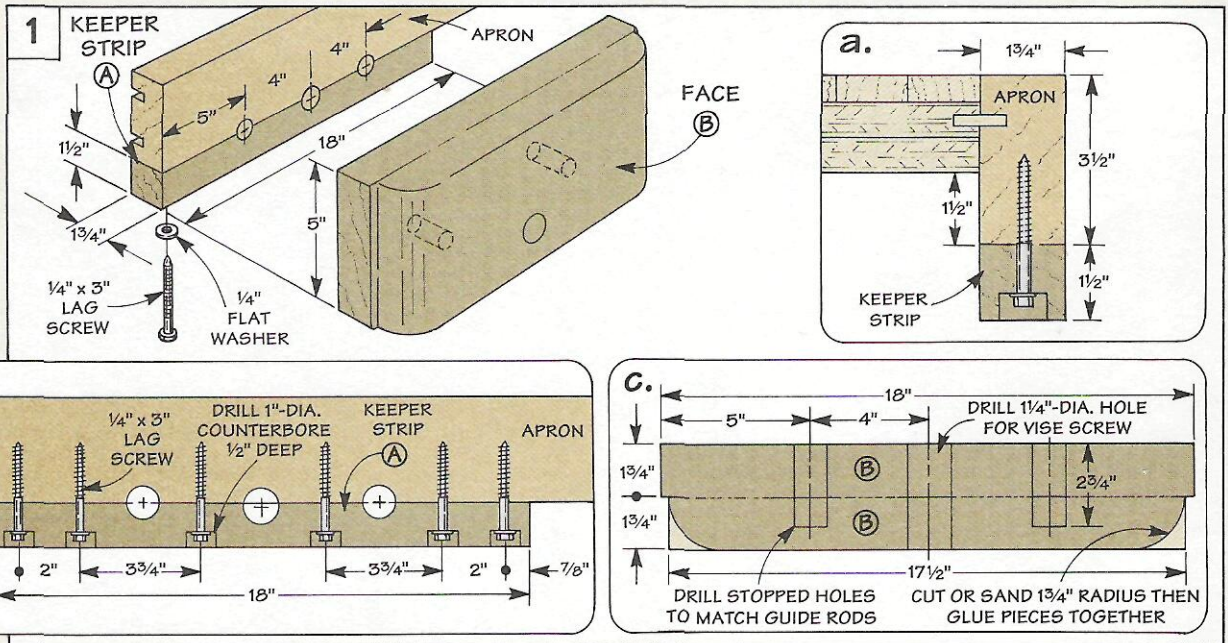

A nail and a scrap block lets you file an equal amount off both the edges of a spade bit.

This shop-made vise is modeled after a traditional woodworking vise. With this type of vise a large wood face forms the front jaw. And the apron of the bench acts as the back jaw, see Fig. 1.

If you plan on adding vises to the workbench shown on page 16, it's easier to work on the aprons before they're glued to the bench top. For an existing bench that doesn't have aprons, you'll need to make an apron. (For more on this, refer to page 21.)

Note: To allow clearance for the moving parts of the vise, the apron should extend at least 1 1/2" below the benchtop, see Fig. 1a.

KEEPER STRIP. Once the apron is complete, a *keeper strip* (A) is added to the bottom edge of the front apron. The purpose of the strip is to support two metal guide rods that are added later. To make it easy to install the vise, the keeper strip is attached with six lag screws (no glue), see Fig. 1b.

FACE. With the keeper strip in place, the *vise face* (B) is built up from two pieces of 8/4 (1 3/4"-thick) stock, see Fig. 1c. To give the vise a traditional look, I cut the *outside* piece shorter and rounded

the corners before gluing the pieces together, see Fig. 1c.

At this point, all that's needed is a way to clamp the face tightly against the apron. That's where the vise screw and guide rods

come in. The vise screw provides the clamping pressure while the rods keep the jaws aligned.

The key is to get the holes in the face to align with the holes in the apron. To do this, I made a

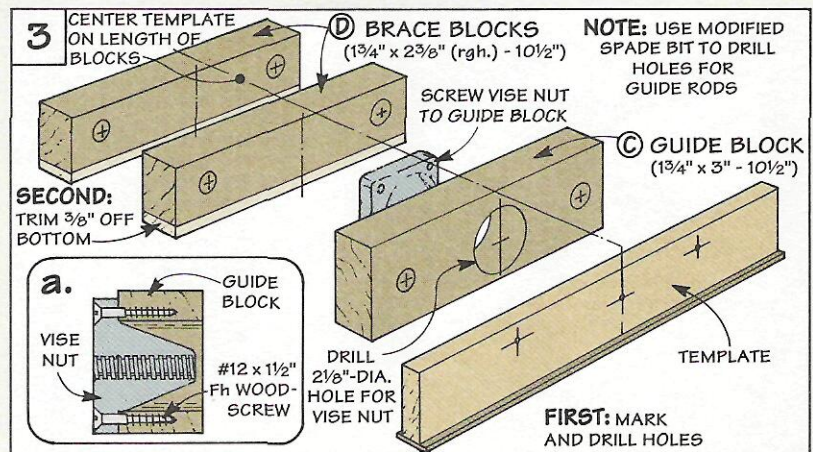
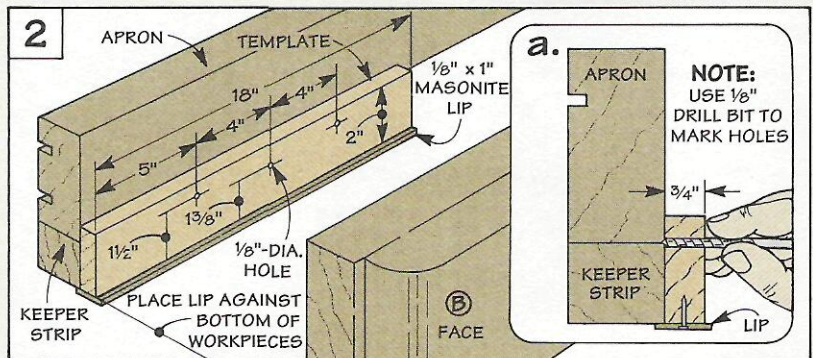

template that has 1/8"-dia. holes to mark the centerpoints of the vise screw and guide rods, see Fig. 2.

By cutting the template the same length as the face and adding a Masonite lip to the bottom, all you have to do is hold the ends flush to mark the holes. (I used a brad point bit, see Fig. 2a.)

DRILL HOLES. Drilling a 1 1/4"-dia. hole through the apron and the face for the vise screw is easy. The tricky part is drilling the holes for the guide rods so they slide smoothly without any "slop."

GUIDE RODS. The problem is the guide rods are made from 3/4" iron pipe and the outside diameter of this pipe is *slightly* more than 1 1/16". The solution is to file a 1 1/8" spade bit to the correct size, see margin tip on page 24.

CARRIAGE. After drilling the holes, the two-part carriage is added. A *guide block* (C) supports the guide rods and houses a nut that's part of the vise screw, see Fig. 3. And two *brace blocks* (D),

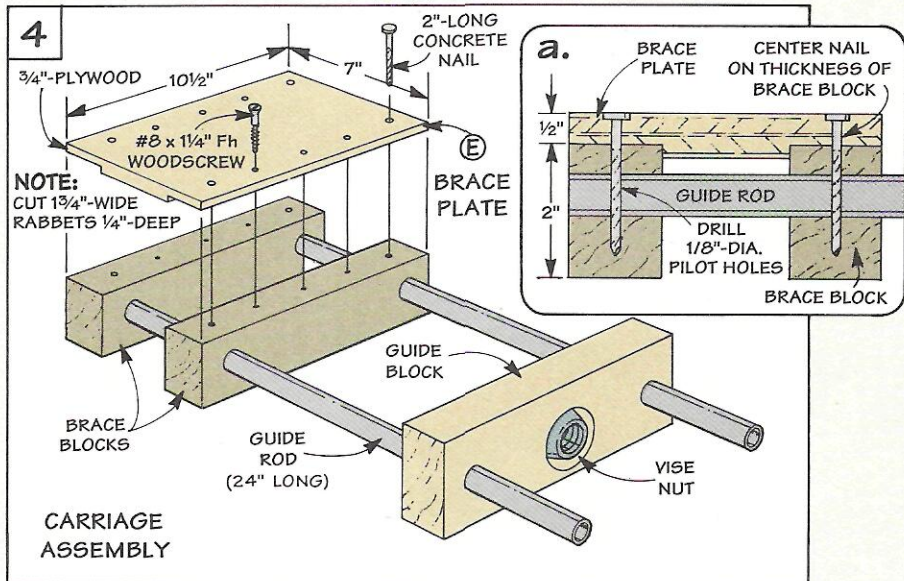

keep the guide rods parallel to each other as the vise is tightened.

Here again, I used the template to locate the holes. The only difference is the blocks are shorter than the template. So you'll need to *center* the template on the *length* of the blocks.

After drilling the holes, the

vise nut is screwed in place, see Fig. 3. Then the bottom edges of the brace blocks are trimmed off to clear the base of the bench.

ASSEMBLY. Now it's just a matter of cutting the guide rods to size (24") and sliding them through the holes in the blocks, see Fig. 4. Then a *brace plate* (E) with two shallow rabbets is glued and screwed to the brace blocks.

PINS. To keep the rods from sliding out of the brace blocks, they're "pinned" in place, see Fig. 4a. (I drilled pilot holes and then drove in hardened steel concrete nails.)

ATTACH VISE. Next, the keeper strip is removed and two *spacer blocks* (F) are glued to the guide block, see Fig. 5. Then, with the spacers snug against the apron, counterbored holes are drilled in the guide block and lag screws are used to fasten it to the benchtop.

INSTALL FACE. At this point, the face can be installed by applying some construction adhesive (PL 400) in the holes and slipping them over the guide rods. As before, the rods are pinned after drawing the face tight against the bench with pipe clamps, see Figs. 6 and 6a.

Finally, the vise screw is threaded into the nut and the mounting flange screwed in place.

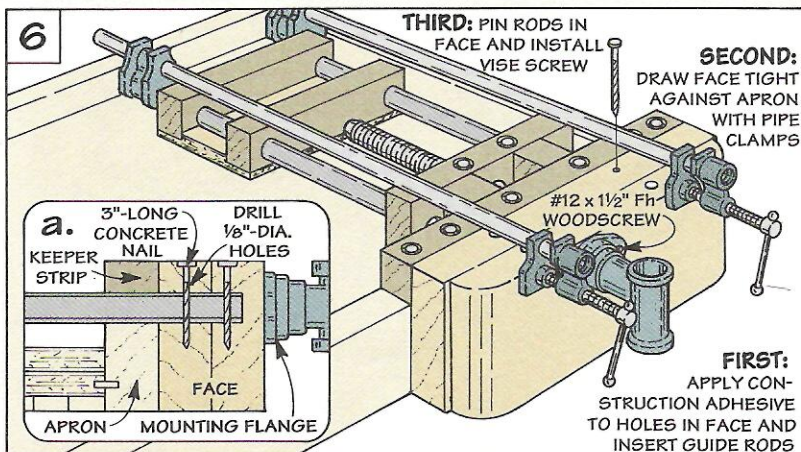
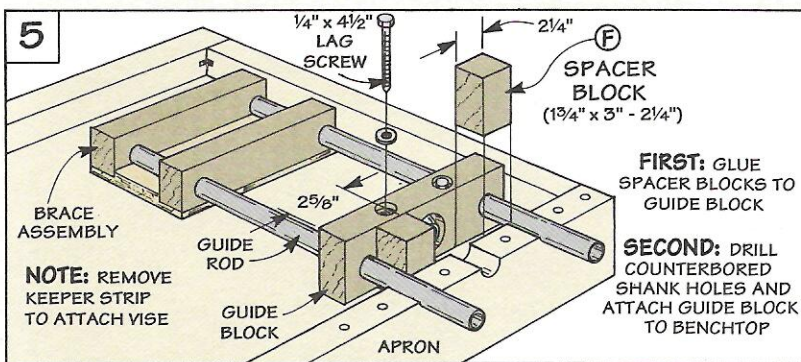

Front Vise (con't.)

Before flipping the benchtop over, the last step is to install a pair of *guide rails* (G), see Fig. 7.

These rails solve a common problem of most vises — the tendency of one end of the vise to rack or “toe in” when a workpiece is tightened in the opposite end. This uneven clamping pressure can cause a workpiece to slip. And it eventually enlarges the guide rod holes in the face.

To solve the problem, the rails “harness” the rods so they can’t move from side to side. This keeps the vise face parallel to the edge of the bench.

INSTALL RAILS. To make this work, the rails are cut to fit between the front and back aprons. Then, they’re fastened to the benchtop. An easy way to locate the rails is to mark the path of the brace plate (E) on the benchtop with the vise in the open and closed position, see Fig. 7. Then screw the rails to the top using the lines as a reference.

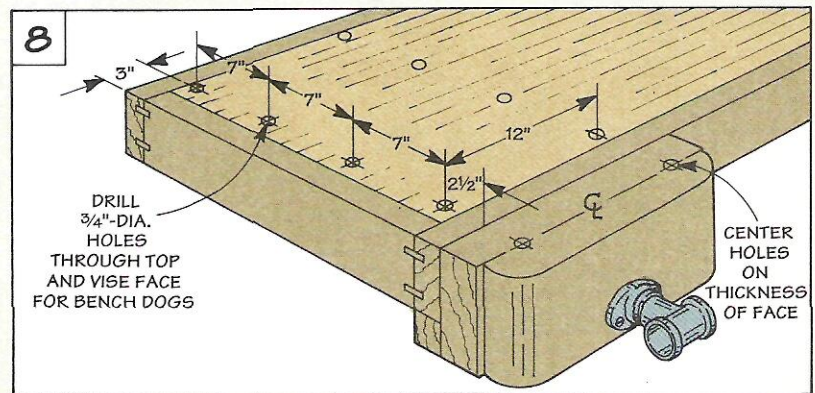
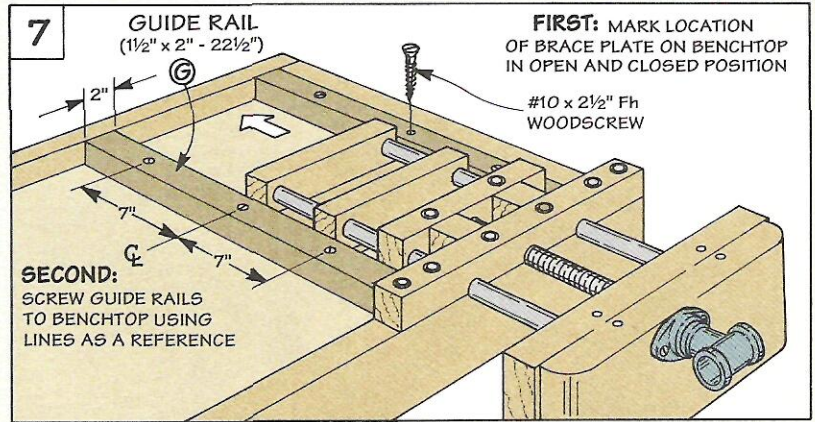

BENCH DOGS & HANDLE

At this point, the vise can be used to clamp a workpiece against the edge of the bench. But to clamp work flat on the top, I added a bench dog system.

This system has two basic components: holes and bench dogs. First, two rows of holes are drilled across the benchtop and the top edge of the face, see Fig.

8. As the vise is tightened, work is clamped between stops or “dogs” that fit in the holes.

BENCH DOGS. The dogs can either be made of metal or wood. (For sources of brass dogs, see page 31.) To make wood dogs, all it takes is a 3/4"-dia. dowel.

The dowel is ripped *offcenter* on the bandsaw, see Fig. 9a. Then, a tapered “flat” is filed on both ends of the thick piece.

After trimming the thin piece

to length and gluing the pieces together, the bottom flat creates a “spring” that holds the dog in place. And the top flat forces work down onto the bench as the vise is tightened.

HANDLE. To complete the vise, I added a *handle* (H) and two *caps* (I). The handle is just a piece of 1"-dia. dowel, see Fig. 10. And the caps are beveled wood blocks with holes drilled in the center, see Fig. 10a.

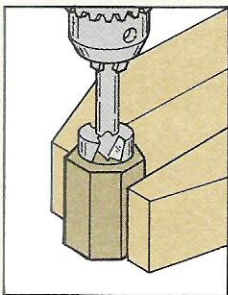

A wooden hand-screw supports the sides of the cap when drilling the hole for the handle.

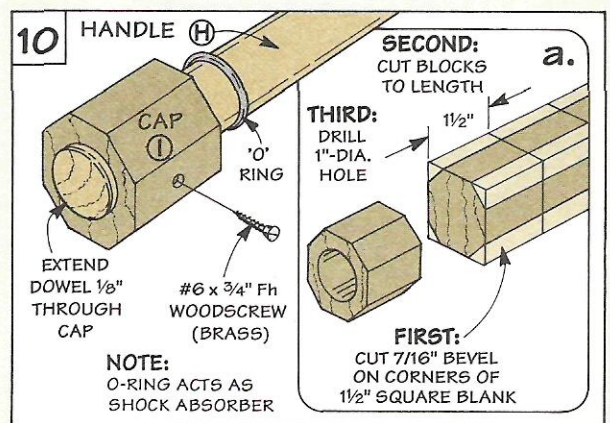
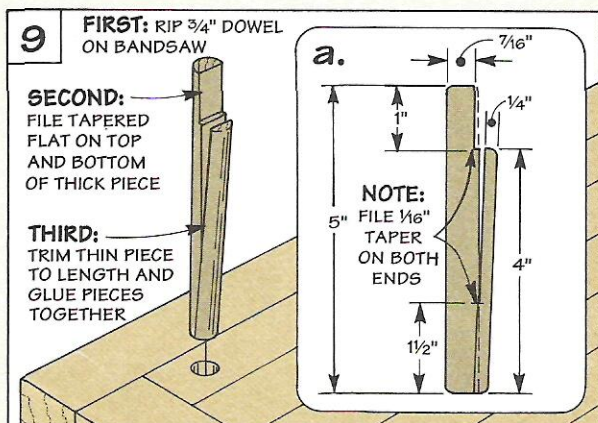

End Vise

The end vise is built the same way as the front vise. It's just longer. As a result, you'll need to change the size of a few parts, see Materials List.

FACE. The most noticeable difference is the length of the face (26" in my case). It spans the width of the benchtop which allows you to clamp longer work.

KEEPER STRIP. Increasing the length of the face also requires a longer keeper strip. Like the front vise, it combines with the apron to form the back jaw. But because the side apron fits between the front and back aprons, the keeper strip extends $1\frac{3}{4}$ " (the thickness of the aprons) on each end, see Fig. 11.

HOLE LOCATION. Another difference is the location of the holes for the guide rods. To distribute the clamping pressure evenly, the guide rods are farther away from the vise screw.

CARRIAGE. With the rods farther apart, the guide block and brace blocks also need to be longer, see Fig. 12. And, to make the brace blocks more rigid, the brace plate is larger.

GUIDE RODS. But a large brace plate reduces the maximum opening of the vise — if the guide rods are the same length as the rods on the front vise. To create the same size opening as the front vise, the guide rods are 30" long.

INSTALLATION. After cutting

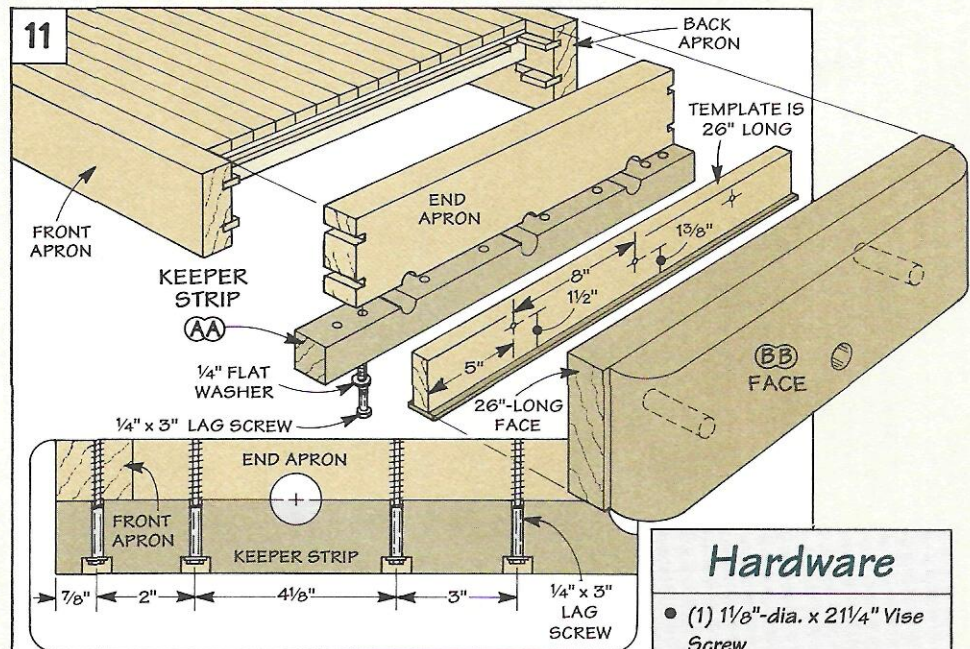

Materials List

AA Keeper Strip (1)	$1\frac{3}{4}$ " x $1\frac{1}{2}$ " - 26"
BB Face (two pieces)	$1\frac{3}{4}$ " x 5" - 26" (rgh.)
CC Guide Block (1)	$1\frac{3}{4}$ " x 3" - $18\frac{1}{2}$ "
DD Brace Blocks (2)	$1\frac{3}{4}$ " x $2\frac{3}{8}$ " (rgh.) - $18\frac{1}{2}$ "
EE Brace Plate (1)	13" x $18\frac{1}{2}$ " - $\frac{3}{4}$ " Plywood
FF Spacer Blocks (2)	$1\frac{3}{4}$ " x 3" - 6"
GG Guide Rails (2)	$1\frac{1}{2}$ " x 2" - $44\frac{1}{4}$ "
HH Handle (1)	1"-dia. Dowel - 14"
II Cap (2)	$1\frac{1}{2}$ " x $1\frac{1}{2}$ " - 1"

Note: Parts cut from (1) $1\frac{3}{4}$ " x $9\frac{1}{2}$ " - 96" piece.

the rods to length, the end vise is installed the same way as the front vise. But the guide rails that "track" the brace blocks are longer. I cut them to fit between the guide rail of the front vise and

the end apron, see Fig. 13.

DOG HOLES. One final change is the dog holes. They're still 7" apart. But they run down the length of the bench to allow you to clamp larger projects.

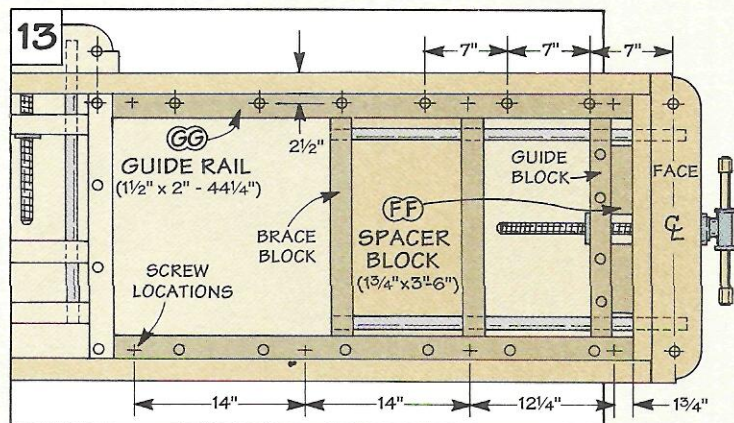
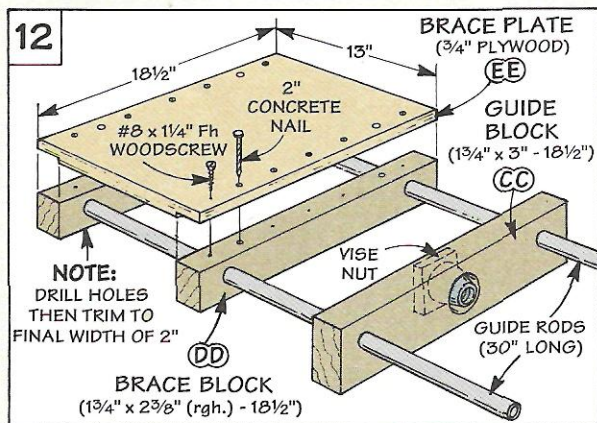

Shop Solutions

Dowel Cutting Jig

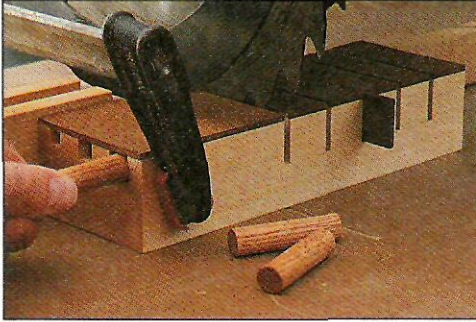

■ Here's a simple jig that makes cutting dowels easy. It's just a block with grooves that are sized to accept $\frac{1}{4}$ ", $\frac{3}{8}$ ", and $\frac{1}{2}$ "-dia. dowels, see Fig. 1.

To keep the dowels from bouncing out of the grooves, I used $\frac{1}{8}$ "-thick Masonite for the top. And used another piece of Masonite as a stop to set the

length of the dowels, see Fig. 2.

To cut dowels, first clamp the jig to your radial arm saw. Then set the stop strip to the dowel length you want, see Fig. 2. After you've cut the dowel, slide the strip out of the way and push the dowel through.

*Andrew R. Swaney Jr.
Fredericksburg, Virginia*

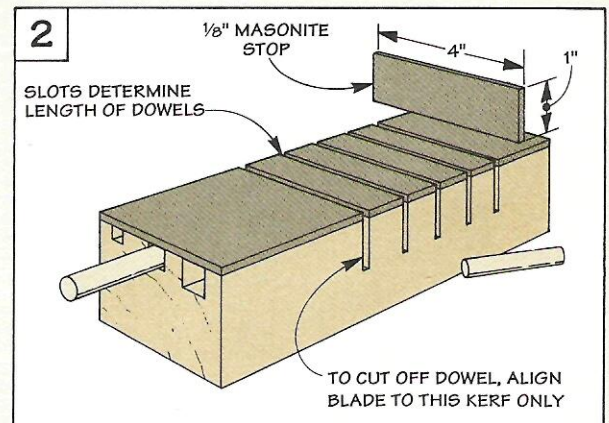
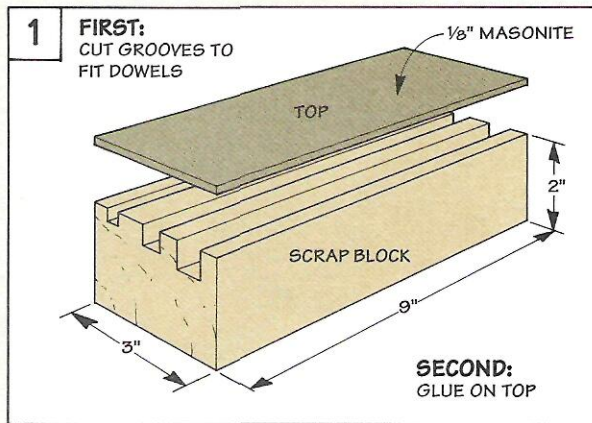

Shop-Made Bench Clamp

■ When you plane or sand a board, it's a good idea to clamp it down. The problem is the clamps get in the way. My solution is to use a pipe clamp and a few pieces of hardware.

The idea is to mount the clamp to the side of the bench top. To do this, I used eye bolts and threaded inserts, see drawing. (The inserts allow me to quickly remove the clamp.) Then, to allow clearance for the jaws, I added two spacers.

Since I wanted to be able to work the entire surface of a $\frac{1}{2}$ "-thick workpiece without hitting the jaws, I positioned the clamp so the jaws are no more than $\frac{3}{8}$ " above the bench top, see Fig. a.

*Bob Easler
Des Moines, Iowa*

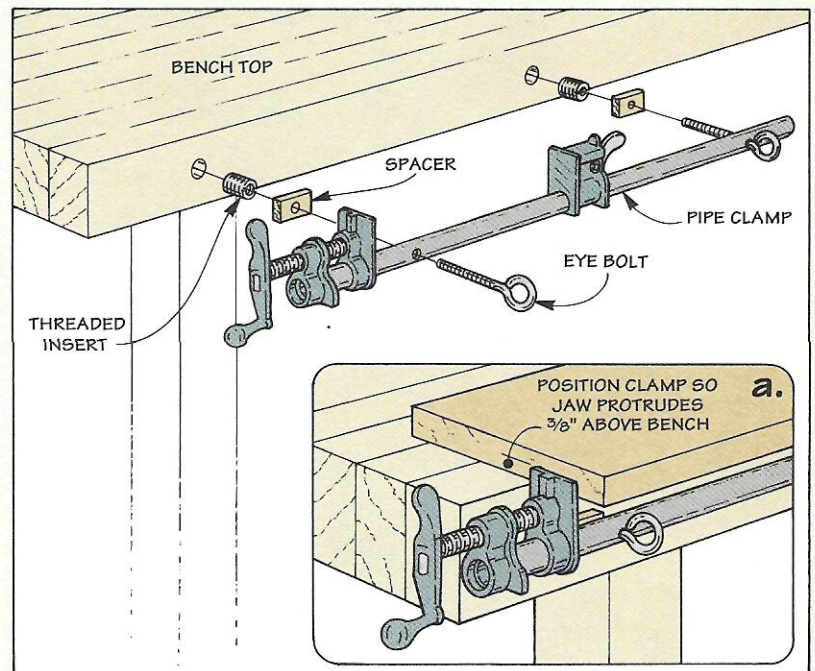

Rip Fence Alignment Gauge

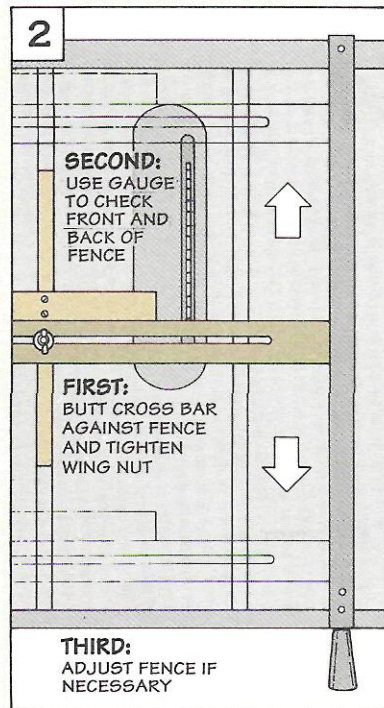
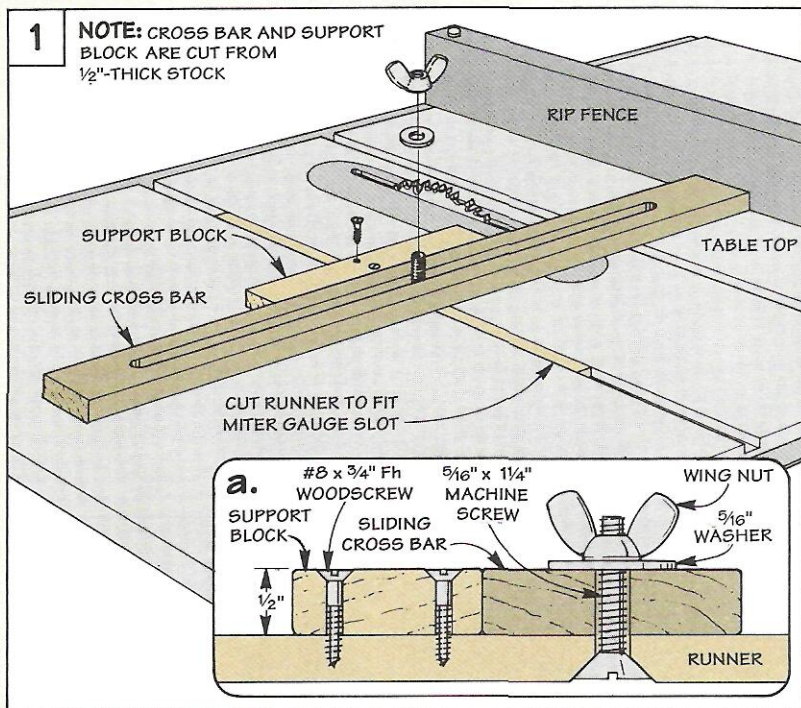

■ I've had a recurring problem with my table saw. When ripping a board, it often binds. The problem was my rip fence doesn't lock down parallel to the saw blade. So to solve this, I made an alignment gauge that allows me to quickly check that the fence is parallel to the blade before I make a cut.

CROSSBAR. The heart of the gauge is a *sliding crossbar* that checks if the fence is parallel to the blade, see Fig. 1. To make sure the crossbar remains perpendicular to the blade and fence during alignment, I screwed a

support block to a *runner* that fits the miter gauge slot.

SET-UP. To use the alignment gauge, first set the distance you want between the fence and blade. (Set and check this distance by measuring between the blade and fence.) Then lock the fence in place.

ADJUST CROSSBAR. Next, set the runner in the miter gauge slot and slide the gauge forward until the sliding crossbar just touches the blade, see Fig. 2. Now slide the crossbar over until it butts up against the rip fence and tighten

down the wing nut.

Once the gauge is set up, you can use it to make sure the fence is parallel to the blade. To do this, slide the runner towards the front end of the fence, see Fig. 2.

If the crossbar binds, tap the fence away from the blade. But if you see daylight between the fence and crossbar, then just tap the fence towards the blade.

After the front end of the rip fence is set, check the other end in the same manner, see Fig. 2.

Milton L. Stover
Sarasota, Florida

Glue Brush Tip

■ Recently, I went to glue up a project and realized I was out of glue brushes. Instead of driving to the hardware store, I decided to try an old tooth brush.

It worked great. The bristles pushed the glue around well. And the brush was wide enough to cover the entire edge in one pass.

Ken Ross
Grove City, Ohio

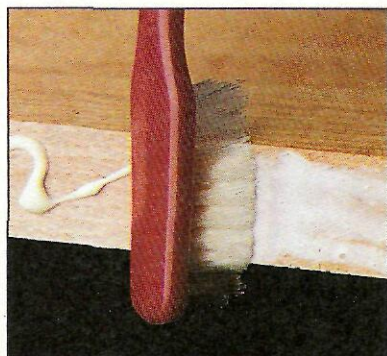

Send in Your Solutions

If you'd like to share original solutions to problems you've faced, send them to: *ShopNotes*, Attn.: Shop Solutions, 2200 Grand Ave., Des Moines, IA 50312.

We'll pay up to \$200 depending on the published length. Send an explanation along with a photo or sketch. Include a daytime phone number so we can call you if we have questions.

Board Footage

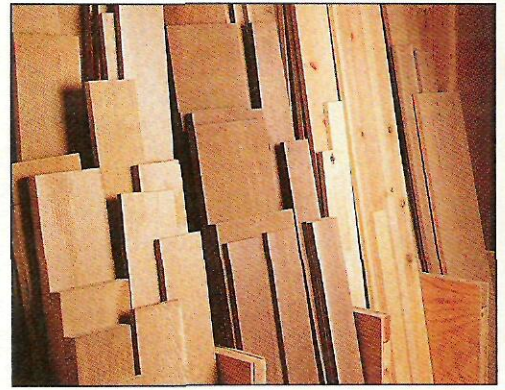

■ Some lumber stores tag the price of each piece of wood. Others don't. When they're not labeled, how can I calculate the cost of the wood?

Mark Benda
Forest City, Iowa

What's the difference between a board foot and a square foot? It has to do with the thickness.

The price of hardwoods is usually calculated in dollars per board foot. So in order to determine the cost of the wood, you'll first need to calculate the number of board feet in each piece.

BOARD FEET. A board foot is a volume measurement that includes thickness and width as well as length, see drawing below. This means two boards of the same thickness can be different length and widths and still have the same board footage.

CALCULATIONS. To determine the board feet in a piece of lumber, start by measuring the piece in inches (not feet), and convert the fractions to the next inch. For example, 5½" becomes 6", and 4 feet 3⅝" (51⅝") becomes 52".

In figuring board feet, anything less than 1"-thick is figured

at the full rough dimension. For example, ¾"-thick or 1⅜"-thick stock is figured as 1"-thick.

After finding the dimensions, multiply the thickness of the piece times the width times the length. Say you've got a ¾"-thick board that's 5½" wide and 96" long.

To determine the board feet, start by multiplying 1" x 6" x 96". This gives you a total of 576 square inches. Now divide the total by 144 (the number of square inches in a board foot). In the example, this would be 4 board feet.

COSTS

Once you know the number of board feet, multiply that number times the cost per board foot to get the cost of the board. To get the total cost for a project, just multiply the total board footage by the cost per board foot.

For example, the workbench on page 16 uses about 50 board feet of 8/4 (1¾"-thick) stock. We paid \$2.50 per board foot for maple. So the hardwood costs \$125.

THICK LUMBER. Also, be aware that thick stock may cost more per board foot. It's best to calculate the board feet of ¾" stock separately from the thicker stock.

THIN LUMBER. Thin lumber can also get confusing. Remember that any board less than 1" thick is figured as if it was 1" thick.

This means that a ¼"-thick board could be listed as having the same number of board feet as a ¾"-thick board that's the same width and length — even though the ¼" board actually has *less* volume of lumber in it.

To eliminate the confusion, the standard practice is to list lumber that's ½"-thick or less in square feet, not board feet.

Basically, this means you pay more for less wood. The reason is, most lumber dealers have to start with thick stock. Then pay to have it surfaced or resawn to make thinner stock.

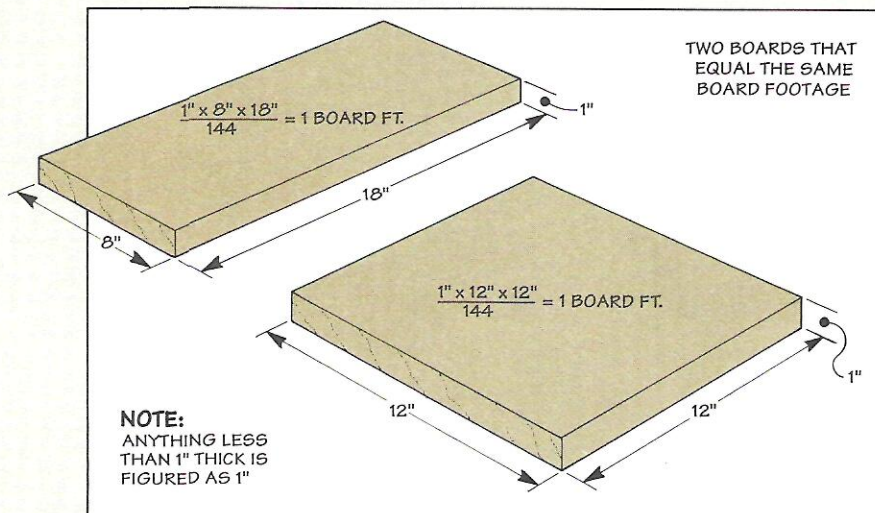

Lumber Questions?

Identifying, selecting, and buying materials for your workshop projects can be a bit confusing.

If you have any questions about lumber or other project materials, send them to: *ShopNotes*, Attn: Lumberyard, 2200 Grand Ave., Des Moines, IA 50312.

Please include a daytime phone number so we can call you if necessary.

Sources

ShopNotes Project Supplies is offering some of the hardware and supplies needed for the projects in this issue.

We've also put together a list of other mail order sources that have the same or similar hardware and supplies.

RAISED PANEL JIG

We're offering a hardware kit for the Raised Panel Jig shown on page 4. The kit includes all hardware (screws, bolts, and washers) necessary to build this project. (You'll need to supply the wood and the 1/4"-thick Masonite.)

In addition to the hardware, we're supplying two pre-cut 16"-long steel rods. (This type of rod is usually available at local hardware stores and building centers.) Also included are a finger guard and special wing nuts.

The finger guard is manufactured to our specifications from optic orange Plexiglas. It comes pre-cut and ready to install.

Finally, to provide a better grip (and more leverage), we've included large plastic wing nuts in the hardware kit.

S6807-100 Raised Panel Jig Hardware\$19.95

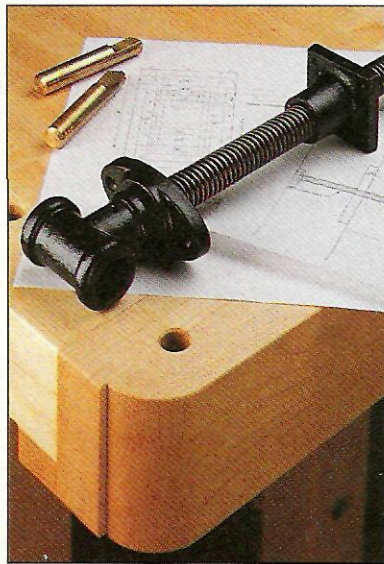

WISE SCREW

ShopNotes Project Supplies is offering the vise screw that we used to make the shop-made vises in this issue, see photo above. (One vise screw is required for each vise.)

This vise screw has an overall length of 21 1/4". Each screw comes with a matching vise nut. (You'll need to supply your own mounting screws, rubber O-rings, and handle.)

Note: After we built the Workbench shown on page 16, the

manufacturer changed the color of the mounting flange and the vise nut from blue to black.

This vise screw is also available from another mail order source listed below.

S1303-1115 ShopNotes Vise Screw\$34.95 ea.

BRASS BENCH DOGS

One way to improve the versatility of any workbench is to add bench dogs. An easy way to do this is to drill 3/4"-dia. holes and use round bench dogs. You can make your own bench dogs, refer to page 26. Or you can purchase metal bench dogs.

ShopNotes Project Supplies is offering bench dogs made from solid brass, so they're less likely to nick your plane blades or chisels. The face of each dog is angled to force the workpiece down on the bench and cross-hatched for a better grip, see photo above.

Note: To get the bench dogs to slide smoothly in the holes, I used a dowel wrapped with sandpaper to enlarge the hole slightly.

For other mail order sources of brass bench dogs, see list below.

S1301-618 Round Brass Bench Dogs (1 pair)\$19.95

MAIL ORDER SOURCES

Similar hardware and supplies may be found in the following catalogs. Please call each company for a catalog or for ordering information.

Bridge City Tools
800-253-3332
Wonderbar

Garrett Wade
800-221-2942
Wonderbar, Brass
Bench Dogs

Highland Hardware
800-241-6748
Wonderbar, Brass
Bench Dogs

Sears
800-366-3000
Keyless Chucks

Trend-Lines
800-767-9999
Keyless Chucks

Veritas
800-667-2986
Vise Screw, Brass
Bench Dogs

Woodcraft
800-225-1153
Keyless Chucks, Brass
Bench Dogs

The Woodworkers' Store
612-428-2199
Keyless Chucks, Brass
Bench Dogs

Woodworker's Supply
800-645-9292
Keyless Chucks, Brass
Bench Dogs

ORDER INFORMATION

BY MAIL

To order by mail, use the form enclosed with a current issue. The order form includes information on handling and shipping charges, and sales tax. Send your mail order to:

**ShopNotes
Project Supplies
P.O. Box 842
Des Moines, IA 50304**

BY PHONE

For fastest service use our Toll Free order line. Open Monday through Friday, 7:00 AM to 7:00 PM Central Time.

Before calling, have your VISA, MasterCard, or Discover Card ready.

1-800-444-7527

Note: Prices subject to change after March 1, 1993.

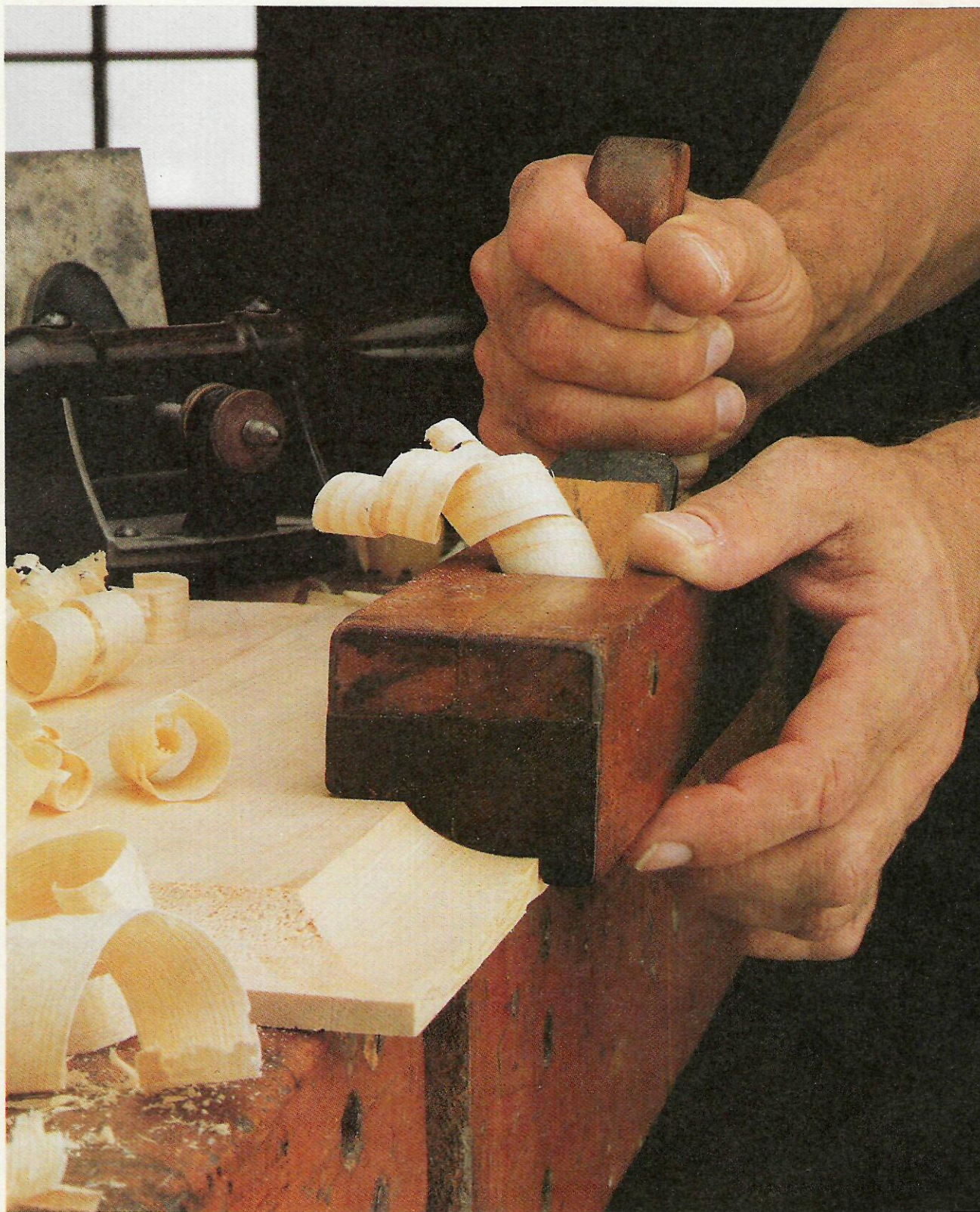

Scenes From the Shop

Before power tools, cabinetmakers relied on their planes to raise the center portion of a panel. They often used a panel raising plane, or a molding plane (like the one shown above). The cutter of the plane was ground to the desired profile and the sole of the plane stopped the blade from cutting as the final profile was reached.