

TIPS • TOOLS • TECHNIQUES

# ShopNotes®

Vol. 2

Issue 8



## MICRO-ADJUSTABLE BOX JOINT JIG

- Sliding Bevel Gauge
- Sharpening Brad Point Bits
- Band Saw Fence System
- Abrasive Pads for Finishing



# ShopNotes

Issue 8

March 1993

**EDITOR** Donald B. Peschke  
**EXECUTIVE EDITOR** Douglas L. Hicks  
**MANAGING EDITOR** Terry J. Strohmman  
**ASSOCIATE EDITOR** Richard S. Peters  
**ASSISTANT EDITOR** Tim Robertson  
**CONTRIBUTING EDITOR** Philip A. Totten

**CREATIVE DIRECTOR** Ted Kralicek  
**ART DIRECTOR** Cary Christensen  
**SENIOR ILLUSTRATOR** Kurt Schultz  
**ILLUSTRATORS** Will Niskanen  
 Roger Reiland  
 Mark Higdon  
**PHOTOGRAPHER** Crayola England

**DESIGN DIRECTOR** Ken Munkel  
**SENIOR DESIGNER** Jan Hale Svec  
**DESIGNER** Kent Welsh  
**SHOP MANAGER** Steve Curtis

#### CIRCULATION

*Circulation Director:* Liz Bredeson • *Subscription Manager:* Phyllis Jessen • *Circulation Analyst:* Rod Cain • *Newsstand Sales:* Kent A. Buckton

#### PUBLISHING SERVICES

*Associate Editor:* Gordon C. Gaippe • *Sr. Graphic Designer:* Robert H. Whitmer

#### CORPORATE SERVICES

*Controller:* Paul E. Gray • *Accounting:* Linda O'Rourke • *Bookkeeping:* Julianne Spears • *Info. Services Manager:* Joyce Moore • *Network Admin.:* Douglas M. Lidster • *Administrative Asssts.:* Cheryl Scott, Julia Fish • *Receptionist:* Jeanne Johnson • *Bldg. Maint.:* Ken Griffith

#### PROJECT SUPPLIES

*Marketing Director:* Robert Murry • *Catalog Art Director:* Cindy Jackson • *Project Supplies:* Linda Jones • *Technical Support:* Jeff Janes • *Systems Operator:* Linda Morrow • *Receptionist:* Keri Lee

#### CUSTOMER SERVICE

*Service Supervisor:* Jennie Enos • *Customer Service Representatives:* Jennifer Murphy, Joy Johnson, Sara Kono, Ami Blanshan, Anna Cox, Chris Lo

#### SHIPPING DEPARTMENT

*Supervisor:* Jerry Carson • *Fulfillment:* Gloria Sheehan, Don McVey, Chuck Carlson, Sylvia Carey

ShopNotes® (ISSN 1062-9696) is published bimonthly (January, March, May, July, September, November) by Woodsmith Corporation, 2200 Grand Ave., Des Moines, IA 50312. Printed in U.S.A.

ShopNotes® is a registered trademark of Woodsmith Corp. ©Copyright 1993 by Woodsmith Corporation. All rights reserved.

**Subscriptions:** Single Copy, \$4.95. One year subscription (6 issues), \$19.95. Two years (12 issues), \$35.95. Canada/Foreign, add \$4.00 per year.

**Second Class Postage** Paid at Des Moines, IA and at additional offices.

Postmaster: Send change of address to ShopNotes, Box 11204, Des Moines, IA 50340-1204

**Subscription Questions?** Call 1-800-333-5854, 8am to 5pm, Central Time, weekdays.

## EDITOR'S NOTE

**F**lawless Fit. Getting pieces to fit together perfectly is one of the most satisfying parts of being a woodworker. Like most woodworkers, it doesn't matter if the project is large or small. If the pieces fit together well, I'm happy. But getting a perfect fit is easier said than done.

Take box joints for instance. Box joints look rather simple and uncomplicated. So making them should be easy. All you have to do is cut a series of slots on the ends of adjoining pieces. Sounds simple enough.

But there's more to making box joints than cutting a bunch of slots. You also have to consider the spacing between each slot (the pin). To make box joints that fit together *perfectly*, the pins and slots need to "mesh" together like the teeth on a pair of gears.

To make good box joints you need to cut the pins and slots with machine-like precision. And that's the idea behind the Box Joint Jig shown on page 6.

**BOX JOINT JIG.** Like many other box joint jigs, this one attaches to your miter gauge and can be used on either a table saw or router table. And like other jigs, it has a "key" to position the workpiece. But what makes this jig unique is the way the key is designed.

**ADJUSTMENT SYSTEM.** The key is designed with a built-in adjustment system that allows you to do two things.

First, the size (width) of the key can be adjusted to fit slots from 1/4" all the way up to 13/16" (the width of a dado blade). This means you can cut different size box joints with only one jig.

Second, you can change the spacing between the slots with the turn of a knob. This allows you to "dial-in" perfect fitting box joints every time.

**SLIDING BEVEL GAUGE.** Getting parts to fit together perfectly is also important when making the Sliding Bevel Gauge (see page 22).

The challenging part is you're working with two different materials — brass and wood. This means that typical woodworking techniques don't apply.

For example, gluing brass to wood is a problem. Whether you use yellow glue, white glue, or even epoxy, you won't get a *permanent* bond. The reason is brass doesn't move with changes in humidity — but wood does. So eventually the bond will break.

**RIVETS.** The solution to this problem is to *mechanically* fasten the pieces together whenever possible. One way to do this is to "rivet" them together.

Rivets allow you to do something screws can't — they can "draw" several pieces together *from both sides* and permanently lock them in place. Basically, it's just a matter of drilling a hole and using a piece of brass rod as a rivet. (For more on this, see page 24.)

**BAND SAW FENCE.** Another project in this issue that uses metal is the Band Saw Fence System (shown on page 16). Adding this system is an inexpensive and easy way to improve the accuracy and precision of your band saw.

The heart of the system is the rails. The rails are made from aluminum angle. It's inexpensive and easy to work with. And it allowed me to solve a problem I've run into when using other band saw fences — "drift." (Drift is the tendency of a band saw blade to pull or lead one way or the other during the cut.)

**ADJUSTABLE RAILS.** The two-piece front rail is designed so you can change the angle of the fence. This way you can compensate for drift and end up with a perfectly straight, precise cut.

**FENCE ACCESSORIES.** To make accurate stopped cuts (like the shoulders of a tenon), the fence is slotted for an adjustable stop block. This slot also allows you to attach a tall auxiliary fence. The extra support this provides makes resawing safe, easy, and accurate.

# Contents

## Router Jointer \_\_\_\_\_ 4

All it takes to get a perfectly straight edge on a workpiece is a hand-held router and this shop-made jig.

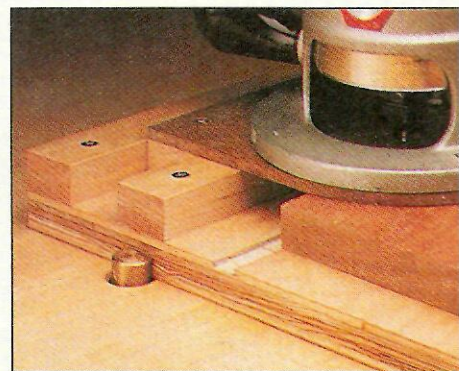

Router Jointer page 4

## Box Joint Jig \_\_\_\_\_ 6

This precision-made jig produces tight-fitting box joints. The secret is a micro-adjustment system that lets you sneak up on the perfect fit.

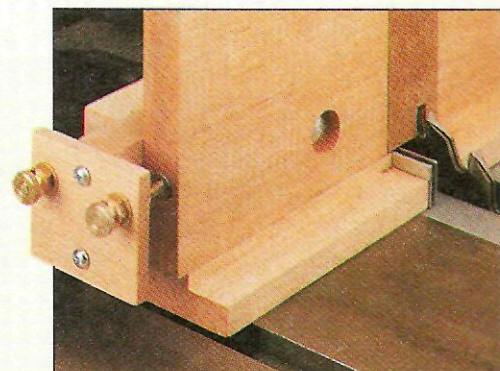

Box Joint Jig page 6

## Making Box Joints \_\_\_\_\_ 12

Professional looking box joints are easy to make with this simple step-by-step approach.

## Sharpening Brad Point Bits \_\_\_\_\_ 14

A file and a few basic techniques are all you need to restore the edge on your brad point bits.

## Band Saw Fence System \_\_\_\_\_ 16

Make perfectly straight cuts on your band saw with this rock-solid fence. It features a built-in clamping system, an adjustment for drift, and two shop-made accessories.

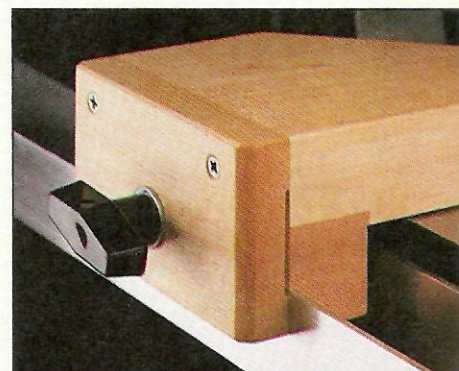

Band Saw Fence page 16

## Sliding Bevel Gauge \_\_\_\_\_ 22

Brass and wood combine to produce a fine tool that's both handsome and functional. Plus, some special techniques for working with brass and wood.

## Shop Solutions \_\_\_\_\_ 28

Seven Shop-Tested Tips: Dust Collector, Assembly Surface, Storing Waterstones, Auxiliary Fence Tip, Keyless Chuck Update, Drill Bit Spacer, and a Blade Guard for Hand Saws.

## Abrasive Pads \_\_\_\_\_ 30

Create a mirror-smooth finish on your projects by using abrasive pads in between coats.

## Sources \_\_\_\_\_ 31

Hardware, project supplies, and mail order sources for the projects in this issue.



Sliding Bevel Gauge page 22

# Router Jointer

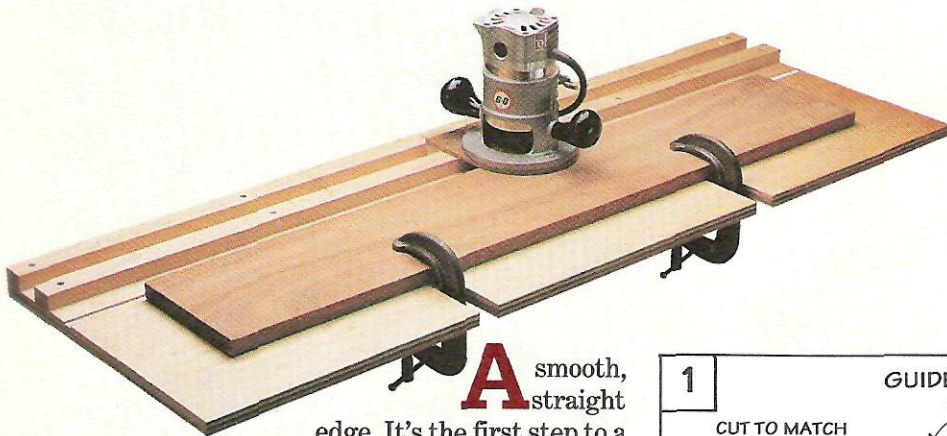

*Creating a straight edge on a workpiece is easy with this simple jig for your router.*

**A** smooth, straight edge. It's the first step to a successful project. To create this edge, you can use a hand plane or a power jointer. Or you can do the job with this simple jig and a router, see photo.

**A JOINTER.** In some ways, this jig is similar to a power jointer—a revolving cutterhead produces a clean, straight edge. On a power jointer the *workpiece* is pushed over a stationary cutterhead. But with this jig, the workpiece is stationary and the *cutter* (a router bit) moves across the edge.

There are two basic parts to this router jointer: a platform, and a sliding carriage.

## THE PLATFORM

I started by building the platform. It's just a plywood base (A), and two guide rails (B), see Fig. 1.

**BASE.** The length of the *base* (A) determines the maximum length of the workpiece that can be jointed. In my case, it's 48" long.

To clamp short or narrow stock to the base, slots are cut in from the front edge, see Fig. 1.

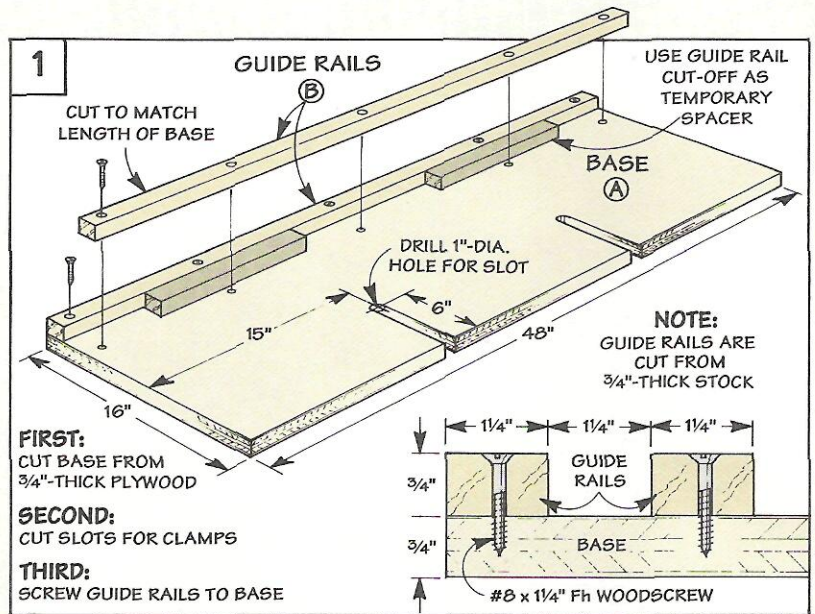

**GUIDE RAILS.** All that's left to complete the platform is to add the *guide rails* (B), see Fig. 1. These rails form a "track" to guide the carriage.

The thickness of these rails determines the *maximum* thickness of the workpiece. Since I do most of my work with 3/4"-thick stock, I made the guide rails the same thickness (3/4"), see Fig. 1.

To make the rails, start by cutting two 1 1/4"-wide blanks to a

rough length of 60". Then, trim the rails to match the length of the base (48"), see Fig. 1. Note: Save the cut-offs.

**CUT-OFFS.** I used the cut-offs for two things. First, they serve as temporary spacers to position the guide rails. Second, one piece is used later to make the carriage.

**ASSEMBLY.** The important step in assembling the platform is to get the correct spacing between the rails. This ensures that the

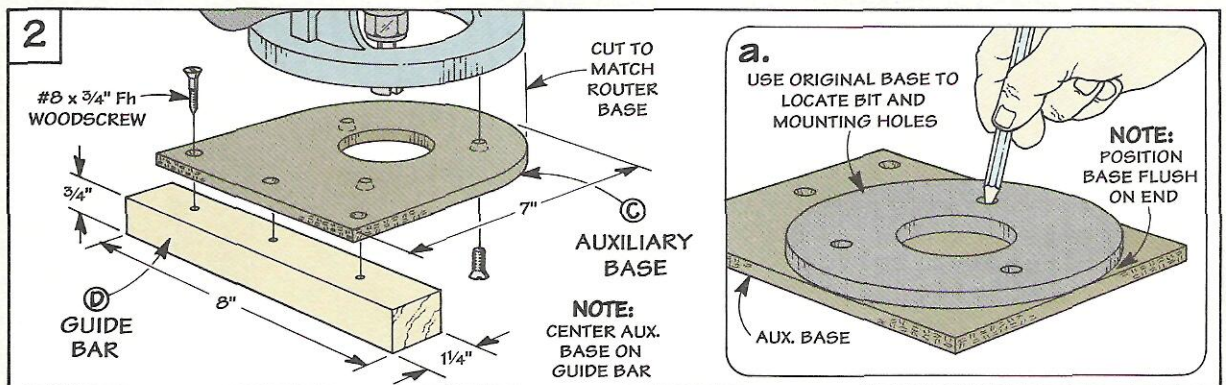

carriage will slide without binding and yet not have any side to side play.

To do this, first screw one rail flush with the back edge. Then, put the spacers between the rails and screw the other rail in place.

**CARRIAGE**

With the platform complete, work can begin on the carriage. It consists of an auxiliary base for your router and a guide bar, see Fig. 2.

**AUXILIARY BASE.** The *auxiliary base (C)* is just a piece of 1/4"-thick Masonite. One end is screwed to the guide bar. The other end rests on your workpiece, refer to Drawing below.

The auxiliary base is 7" long and cut to match your router base, see Fig. 2. To locate the bit and mounting holes in the Masonite, use your original router base as a template, see Fig. 2a.

**GUIDE BAR.** The next step is to add the *guide bar (D)* that rides in the "track" of the platform. To do this, cut one of the guide rail spacers to a length of 8". Then center the base on the guide bar

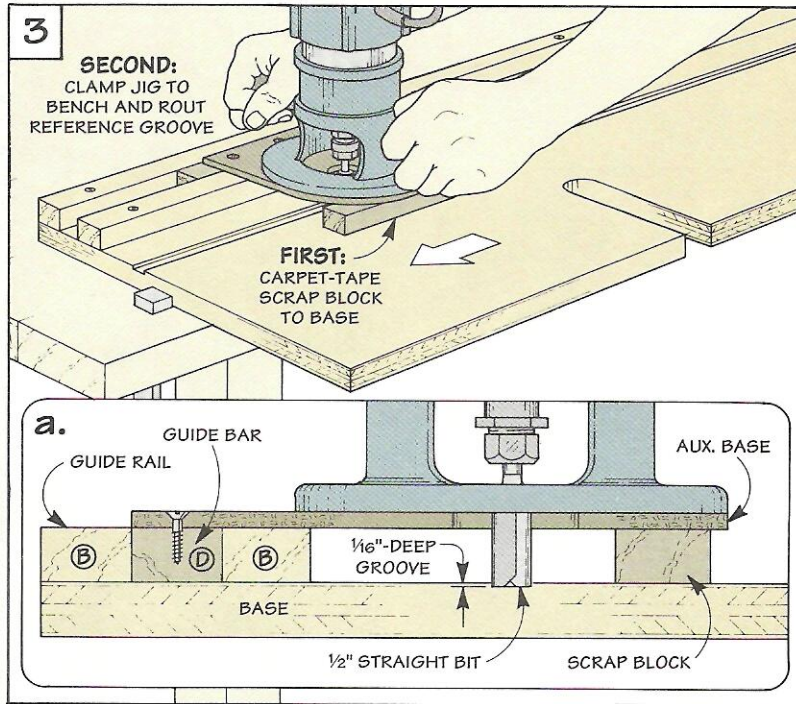

and screw it in place, see Fig. 2.

Now insert a straight bit (I use a 1/2" bit) and mount the router to the auxiliary base.

**ROUT GROOVE.** To create a reference for jointing the edge of a board, a shallow groove is routed in the base. (For more on

setting up the jig, see box below.)

Since there's no workpiece under the router, it can tip while routing. To prevent this, carpet tape a 3/4"-thick block to the bottom of the auxiliary base. Then set the bit to cut 1/16"-deep, and rout the groove, see Fig. 3.

**Using the Router Jointer**

There are two steps to using the router jointer after you've clamped it to your bench. First, position and clamp your workpiece to the jig, see Drawing. Then it's just a matter of sliding the carriage to joint the edge.

**POSITION WORKPIECE.** To position a workpiece, place the *rough edge* to be jointed so it extends about 1/16" (the maximum cut) over the groove in the base, see Drawing. Then clamp the board to the base. Note: Make sure the overhang is the same at both ends.

**JOINT THE EDGE.** Then to joint the edge, just slide the carriage from right to left. A single, smooth pass along the entire length of the board works best.

**Thin Stock.** If you want to joint stock that's thinner than 3/4", you'll need to support the carriage so it doesn't tip. To do this, carpet tape a scrapwood spacer to the auxiliary base of the carriage.

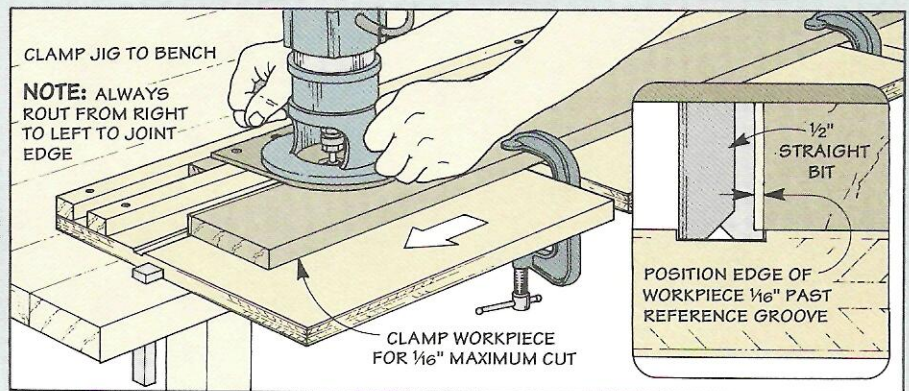
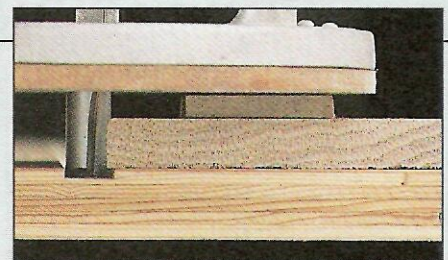

# Box Joint Jig

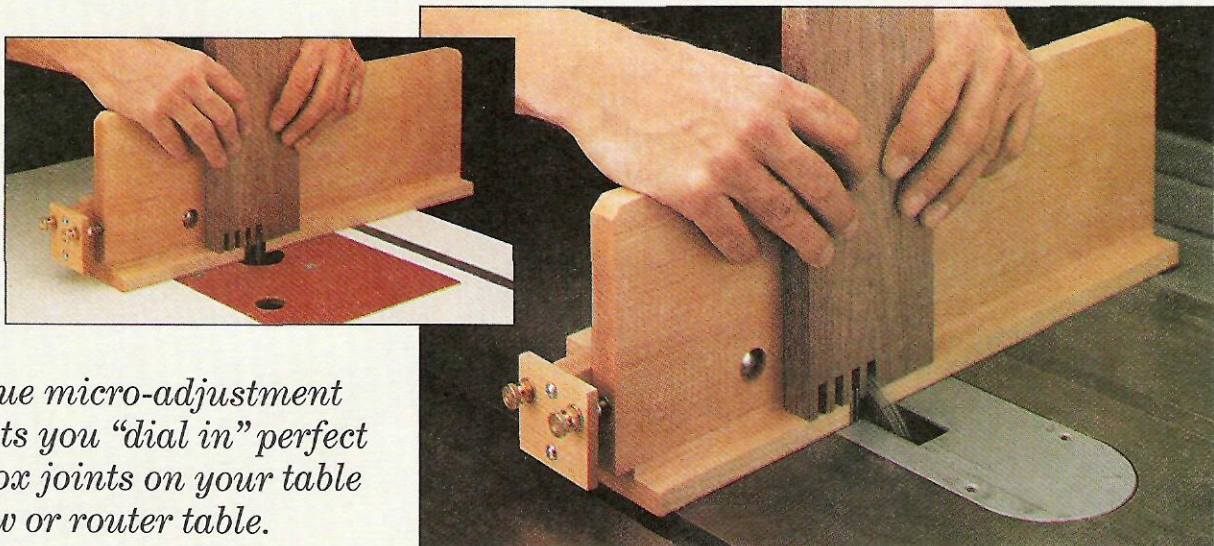

*A unique micro-adjustment system lets you “dial in” perfect fitting box joints on your table saw or router table.*

**T**he thing that impresses me most about this box joint jig isn't the tight-fitting joints you can make with it. After all, that's what you expect from a precision-made jig. What's unique is how quickly and easily it can be adjusted.

Unlike most box joint jigs I've used that require an almost endless amount of “tweaking,” this jig can be set up in a matter of minutes. The secret is a built-in system that lets you adjust the jig in extremely small increments.

**MICRO-ADJUSTMENT SYSTEM.** This system is designed to adjust to the desired *size* and *spacing* of the pins and slots that make up a box joint, see photo A. By simply turning a knob, the jig can be

set to cut slots that range in size from a width of 1/4" to 13/16". A second knob changes the spacing of the pins and slots. This tightens (or loosens) the joint which allows you to sneak up on a perfect fit.

**KEY.** The adjustment system works by moving two metal brackets, see photo B. The brackets form a “key” that automatically positions the workpiece so each slot is cut a uniform distance apart. This creates a series of pins and slots that fit together like fingers in a glove.

**LOCKING FEATURE.** To prevent the key from “creeping” once it's adjusted, a pair of plastic knobs locks it securely in place, see photo C. The result is perfect fitting box joints.

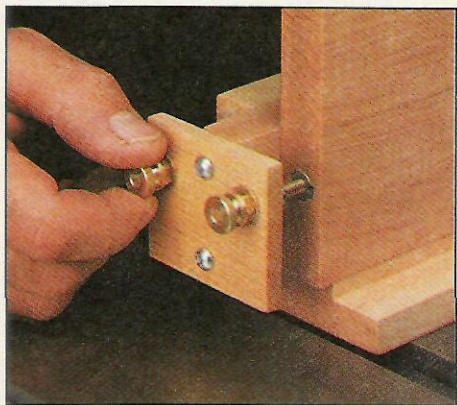

**A. Micro-Adjustment System.** A pair of knobs adjusts the jig to the desired size and spacing of the pins and slots.

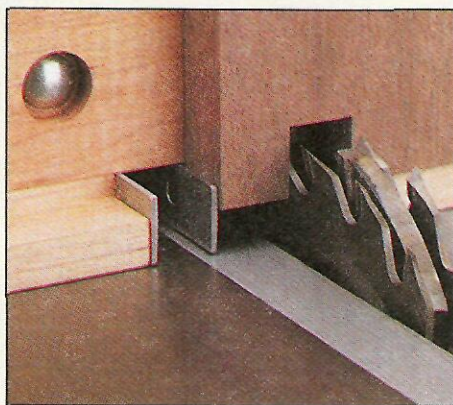

**B. Key.** To cut identically spaced pins and slots, two metal brackets form a “key” that positions the workpiece.

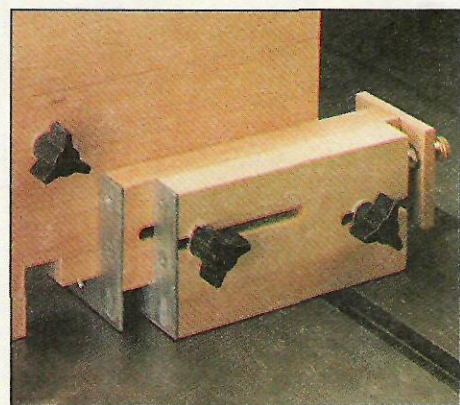

**C. Locking Feature.** After adjusting the box joint jig, it can be locked in place with two plastic knobs.

# FEATURE PROJECT

## EXPLODED VIEW

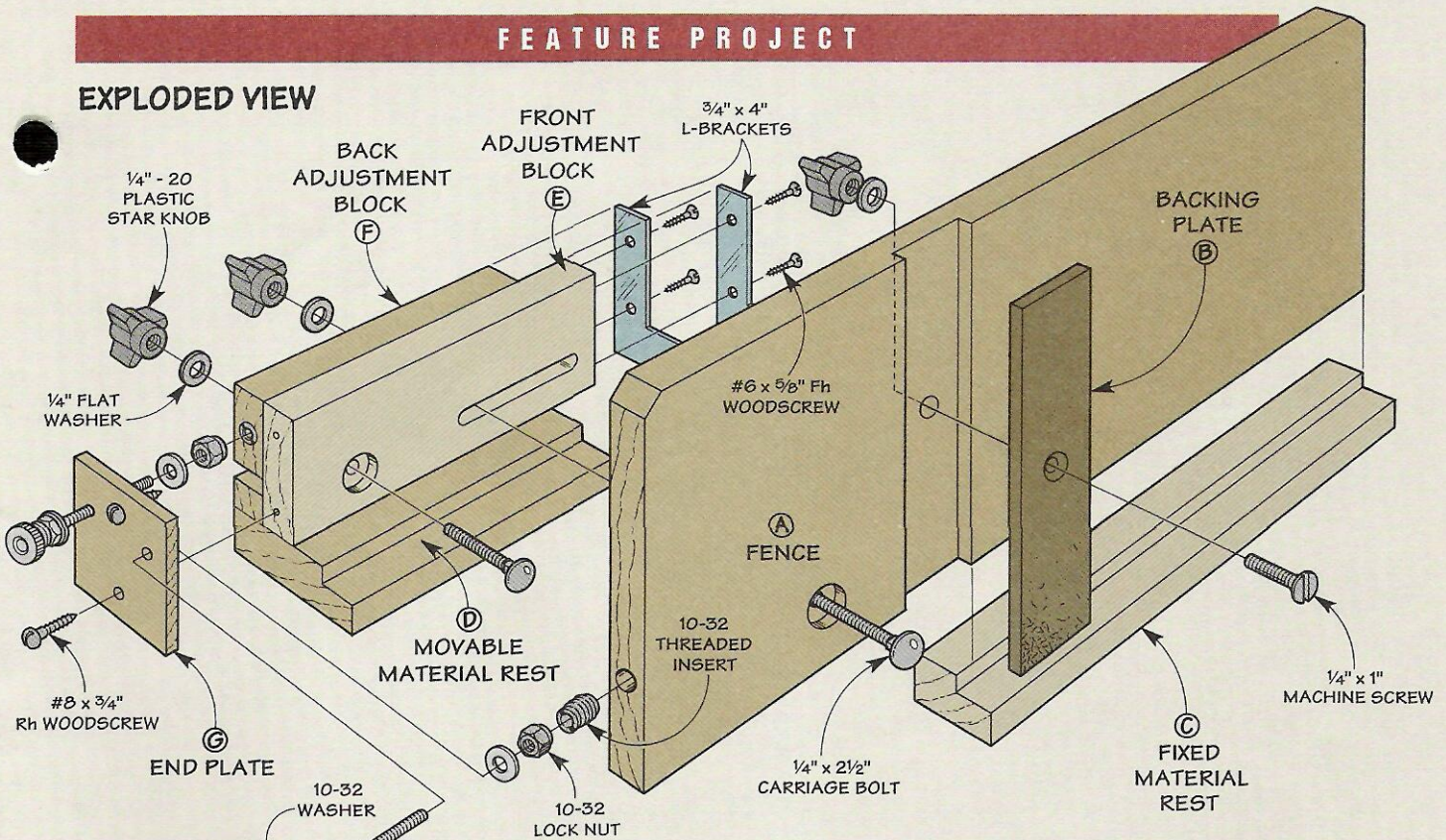

## TOP VIEW

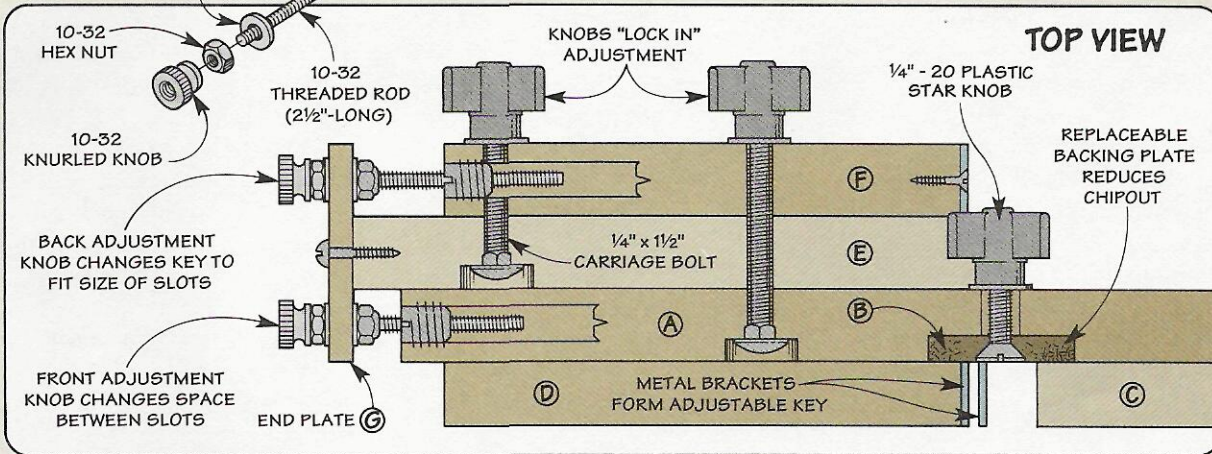

## Hardware

- (1) 1/4" x 1" Machine Screw
  - (3) 1/4" - 20 Plastic Star Knobs
  - (3) 1/4" Flat Washers
  - (2) 3/4" x 4" L-Brackets\*
  - (5) #6 x 5/8" Fh Woodscrews
  - (1) 1/4" x 1 1/2" Carriage Bolt
  - (1) 1/4" x 2 1/2" Carriage Bolt
  - (2) #8 x 3/4" Rh Woodscrews
  - (2) 10-32 Threaded Inserts
  - (4) 10-32 Washers (Brass)
  - (2) 10-32 Lock Nuts
  - (2) 10-32 Hex Nuts (Brass)
  - (2) 10-32 Knurled Knobs (Brass)
  - (2) 10-32 Threaded Rods - 2 1/2" (Brass)
- \* also sold as mending plates

## Materials List

A Fence (1)	3/4 x 5 1/2 - 1B
B Backing Plate (1)	1 1/2 x 5 1/2 - 1/4 Masonite
C Fixed Material Rest (1)	3/4 x 1 1/2 - 1 13/8
D Movable Material Rest (1)	3/4 x 3 - 5 3/8
E Front Adjust. Block (1)	3/4 x 2 - 6 1/2
F Back Adjust. Block (1)	3/4 x 2 - 5 3/8
G End Plate (1)	1/4 x 2 - 2 1/4

# Fence and Material Rest

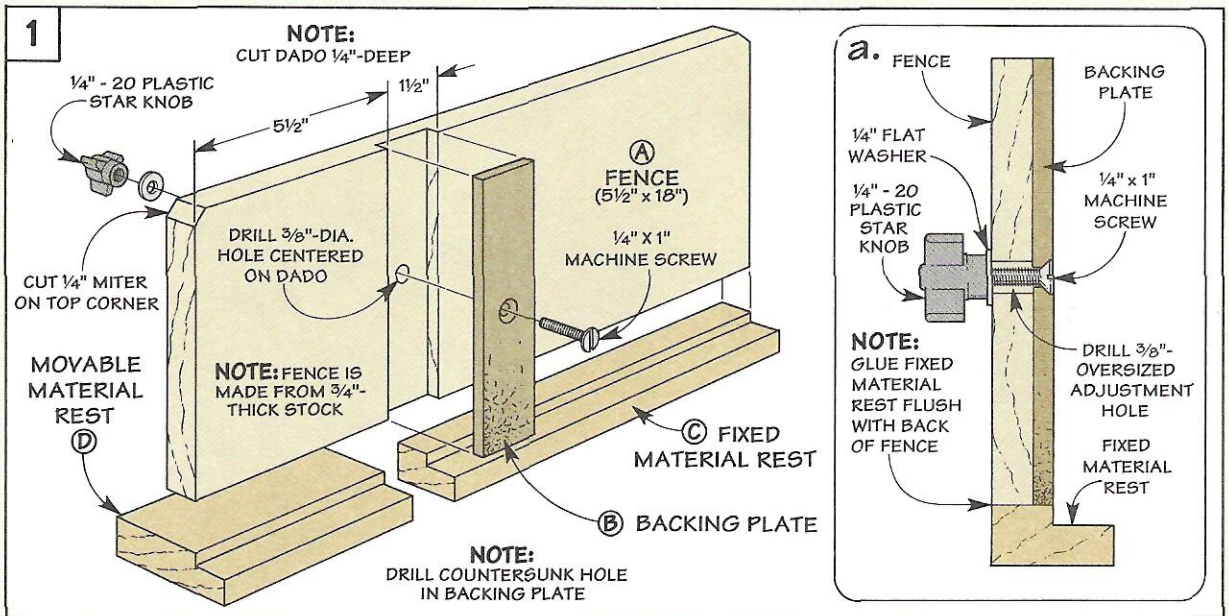

The box joint jig is designed with a tall fence that supports a workpiece when you stand it on end. This lets you cut slots on the *end* of the workpiece by pushing the jig through the blade (or bit).

**FENCE.** The *fence* (A) is just a piece of 3/4"-thick hardwood (maple) with the top corners mitered, see Fig. 1. To provide plenty of support, the fence is 5 1/2" tall (wide) and 18" long.

**BACKING PLATE.** After you've cut the fence to size, the next step is to add a replaceable backing plate. The plate prevents the wood fibers around the back of the slot from chipping out as the blade passes through the workpiece.

So why doesn't the fence alone solve the problem of chipout? Because as the jig passes over the blade, a slot is cut in the *fence* as well as the workpiece. The problem is once a large slot is cut, you've removed the support.

That's where the *backing plate* (B) comes in. It's a piece of 1/4" Masonite that fits in a shallow dado in the fence, see Fig. 1. To make it easy to replace when it gets chewed up, the plate is held in place with a machine screw and knob (or wing nut), see Fig. 1a.

## MATERIAL REST

With the fence complete, the next step is to add a material rest. It serves as a "shelf" to raise the end of a workpiece above the saw or router table. This way, the workpiece spans any irregularities in the table insert that can cause the depth of the slots to vary.

**TWO PARTS.** The material rest consists of two parts. A *fixed rest* (C) is attached permanently to the jig. And a *movable material rest* (D) that slides from side to side, see Fig. 1.

This two-part rest creates an opening that provides clearance for an adjustable "key" that's added later. And it lets you slide the jig through the blade without cutting into the material rest.

**BLANK.** Both parts of the rest start out as a 3/4"-thick blank, see Fig. 2. After cutting a rabbet on one edge to form the shelf, the two parts are cut to final length.

Then the fixed rest is trimmed to width and glued to the bottom of the fence, see Fig. 1. The movable rest is used later as a platform for the adjustment system.

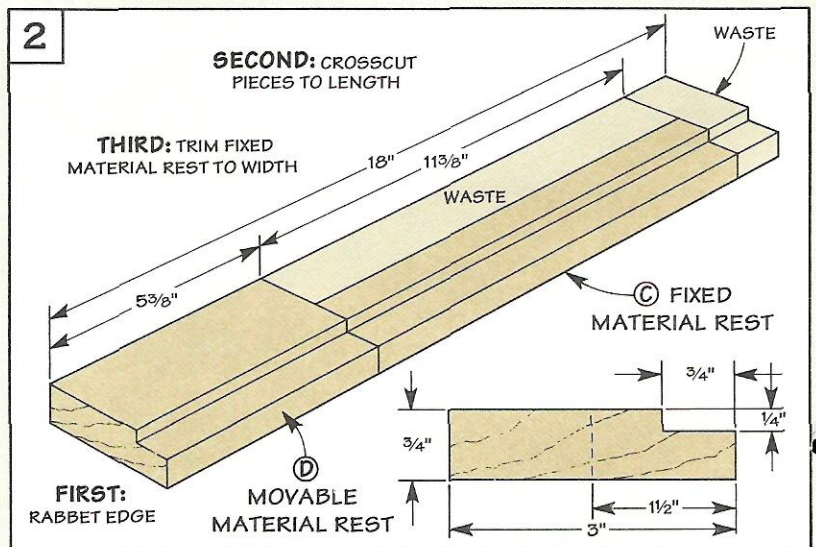



# Adjustment System

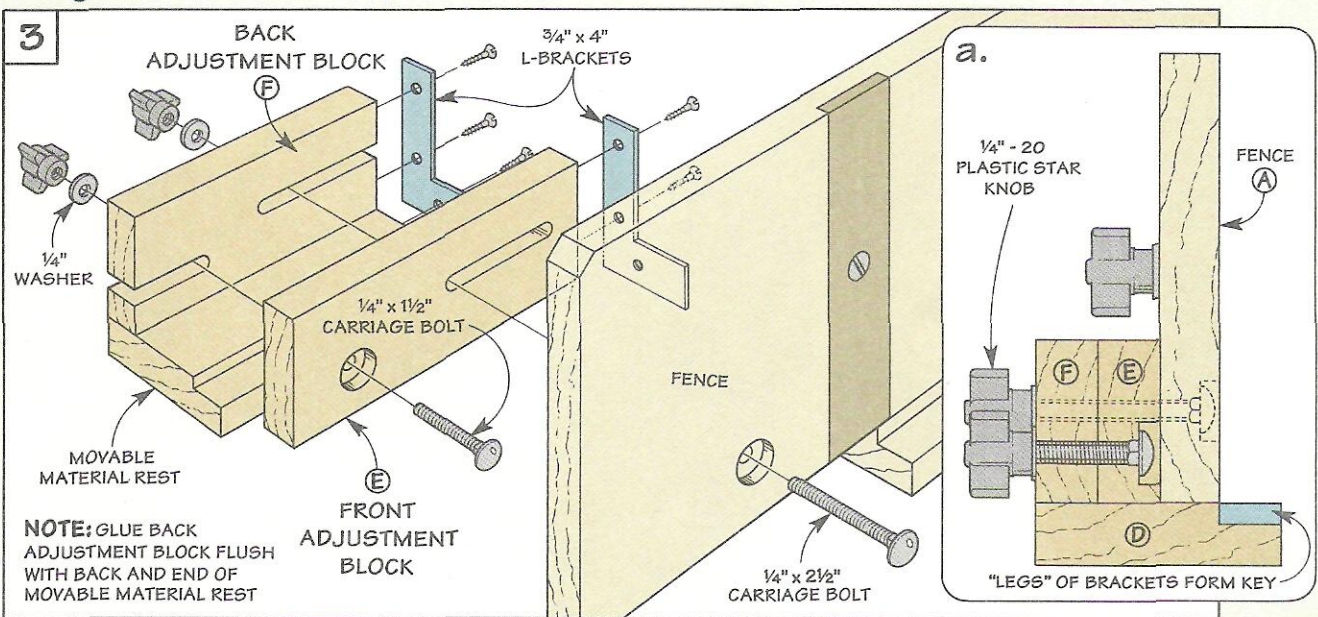

After completing the material rest, work can begin on the adjustment system. Basically, this system consists of two adjustment blocks and a pair of L-shaped metal brackets, see Fig. 3. The blocks and brackets work together to form a "key" that adjusts to the desired size and spacing of the slots that make up the box joint.

**ADJUSTMENT SLOTS.** To make the key adjustable, slots are cut in the *front (E)* and *back adjustment blocks (F)*, see Fig. 4. Then the back block is glued to the movable material rest (D) that was made earlier to create an L-shaped assembly, see Fig. 3.

**KEY.** When the glue dries, the next step is to add the adjustable key. To do this, the L-brackets are attached to the ends of the blocks. These brackets are just 4" mending plates that I picked up at the local hardware store. (See page 31 for other sources.)

The only unusual thing is the brackets need to be modified slightly to fit the adjustment blocks. This requires trimming the ends and drilling an additional mounting hole in each bracket, see Fig. 5.

**ATTACH BRACKETS.** Now the brackets can be screwed to the ends of the blocks so the bottom "legs" are flush with the front edge of the material rest (D). Af-

ter the adjustment system is assembled, the legs will extend in front of the fence and form the key that's used to position the workpiece, refer to Fig. 3a.

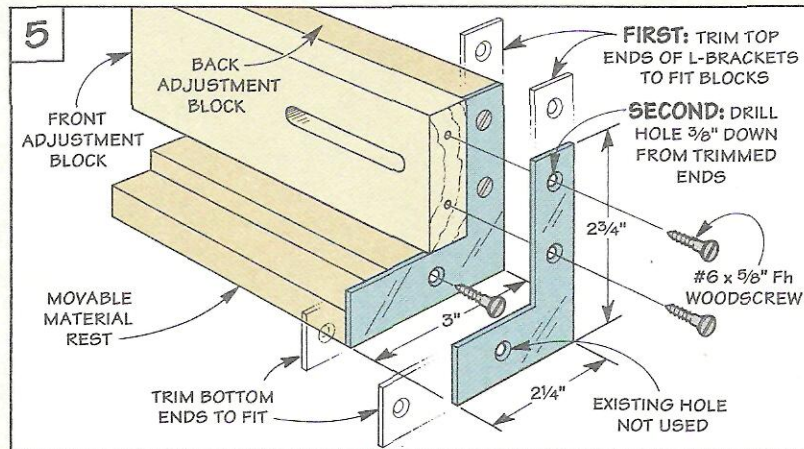
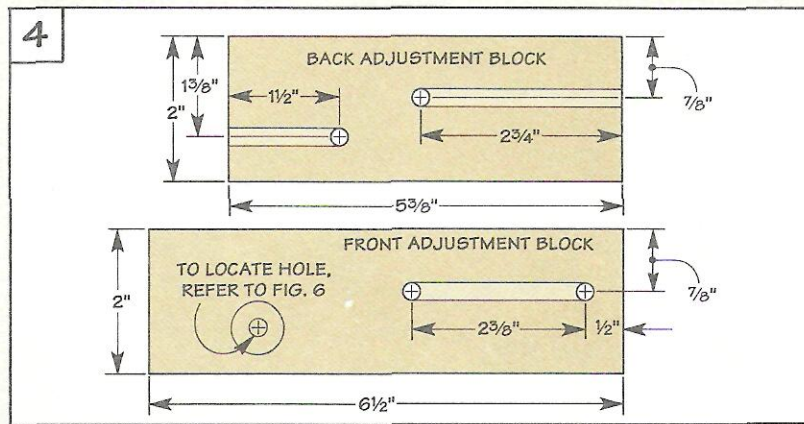

# Locking System

The two adjustment blocks allow you to set the size and spacing of the key. To prevent this key from moving once it's adjusted, I installed a special locking system.

This system has two separate "locks" — one for the *size* of the key, and one for the *spacing* between the key and the blade.

**SIZE LOCK.** To lock in the size of the key, the adjustment blocks are held together with a carriage bolt and knob, refer to Fig. 3a. The bolt passes through a hole drilled in the front block (E) and through the short slot in the back block (F), see Figs. 6 and 6a.

**TEMPLATE.** To ensure the hole in the front block aligns with the slot, I used the back block as a template, see Fig. 6. With the ends of the blocks flush, a 1/4" brad point bit can be used to mark the center of the hole at the *end* of the slot, see Figs. 6 and 6a.

**DRILL HOLE.** After locating the centerpoint, drill a shank hole for the carriage bolt. Then to recess the head of the bolt, I used a Forstner bit to drill a counterbore. Now the carriage bolt can be installed and a washer and knob (or wing nut) threaded on.

**SPACING LOCK.** The next step is to provide a way to lock in the

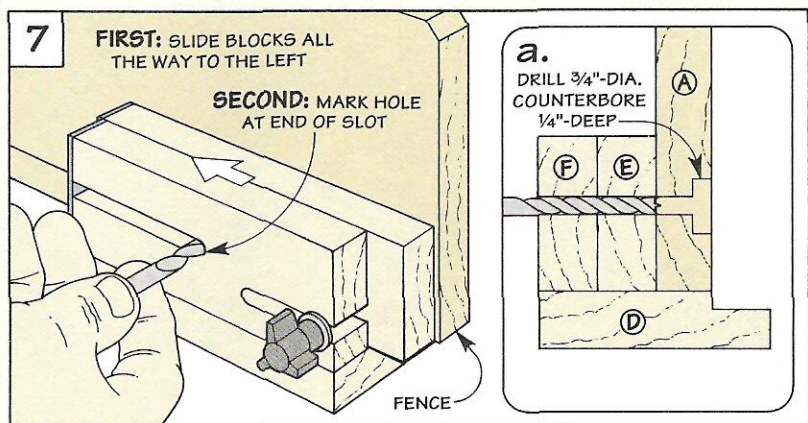
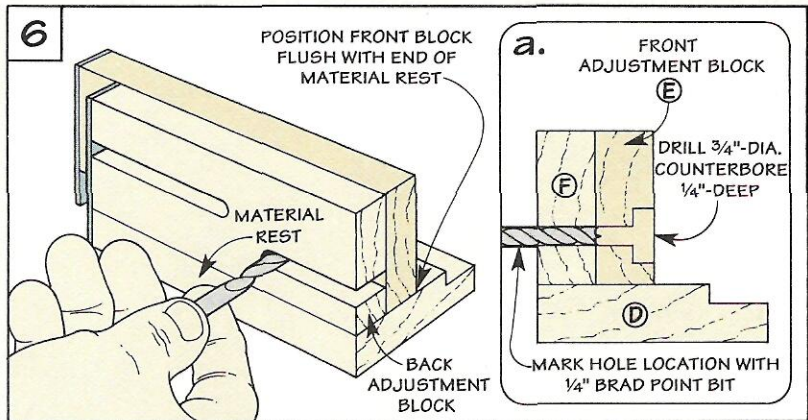

spacing between the key and the blade. Here again, a carriage bolt is used. But this time it passes through a hole in the *fence* and the long slots in *both* blocks.

To locate this hole, place the assembly under the fence. Then

slide the blocks to the left as far as possible, and mark the hole at the *end* of the slot, see Fig. 7.

All that's left is to drill a counterbored shank hole in the fence, see Fig. 7a. Then install a carriage bolt, washer, and knob as before.

## Vertical Drilling Jig

Holding a long workpiece (like the box joint jig) steady when drilling holes in end grain can be a challenge. So when I drilled the holes for the adjusting rods, I used a simple jig, see photo.

It's just a couple of pieces of wood held together at a right angle and a triangular support piece, see Drawing.

To center the hole on the bit, the base is clamped to the drill press table so the upright extends over the edge. Then, with the work clamped to the upright, loosen the table and swing the workpiece under the bit.

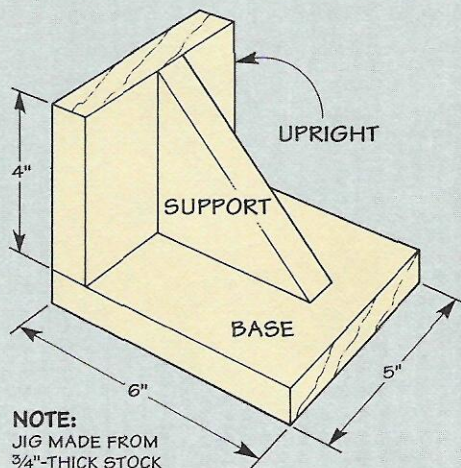

**NOTE:**  
JIG MADE FROM  
3/4\"/>

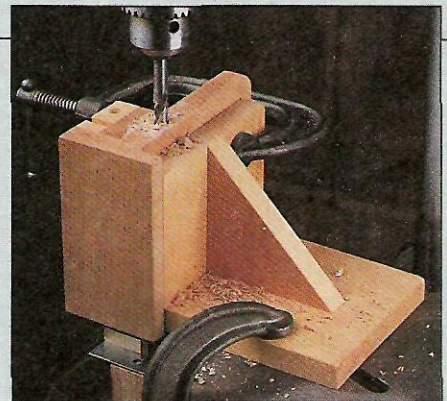

A vertical drilling jig holds long workpieces securely in place when drilling holes in end grain.

# Micro-Adjustment System

The most unique feature of the box joint jig is the micro-adjustment system. This system lets you "fine tune" the key to the desired size and spacing of the slots.

**ADJUSTING RODS.** The secret is a pair of adjusting rods. One rod threads into the end of the back block, and the other into the fence, see Fig. 8. By turning the adjusting rods you slide the blocks from side to side which positions the key. (For more on using the micro-adjustment system, see page 12.)

**ADJUSTMENT ASSEMBLY.** To make this work, an adjustment assembly is attached to the front block (E), see Fig. 8. This assembly consists of a thin wood plate and several pieces of hardware.

**END PLATE.** Before installing the hardware, I made the end plate (G) from a piece of 1/4"-thick hardwood, see Fig. 9a. After drilling holes for the adjusting rods and two mounting screws, the plate can be used as a template to mark the corresponding holes in the end of the jig, see Fig. 9.

**DRILLING JIG.** Marking the holes is easy. The trick is holding the jig steady to drill the holes. To do this, I used a simple drilling jig, see box on page 10. Once the

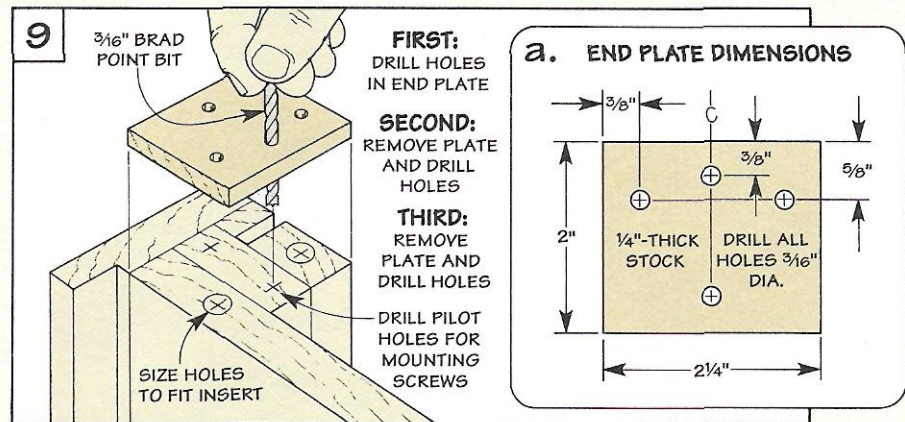
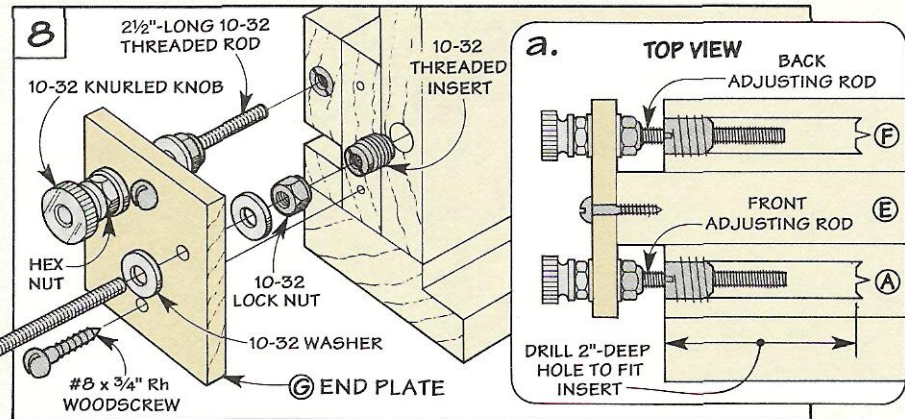

holes are drilled, the micro-adjustment system can be assembled.

The 2 1/2"-long adjusting rods are cut from a piece of threaded rod. To accept the rods, threaded inserts are installed in the fence (A) and back block (F). The actual

adjusting pressure is created by a "stop" on each side of the plate.

The stop on the inside of the plate is a washer and lock nut. Another washer and a knurled knob that's tightened against a nut forms the outside stop.

## MITER GAUGE

The last step is to attach the jig to the miter gauge. The idea is to position the jig so you can cut the largest possible slot without cutting into the material rest.

This requires mounting your widest dado blade (or largest bit). In my case, this was a 1 3/16" dado blade, see Fig. 10. Note: Since I don't like to remove that much material with a router, the largest router bit I use is a 1/2" straight bit.

To complete the jig, check that the miter gauge is square to the blade. Then position the fixed rest against the blade and screw the gauge to the fence, see Fig. 10a.

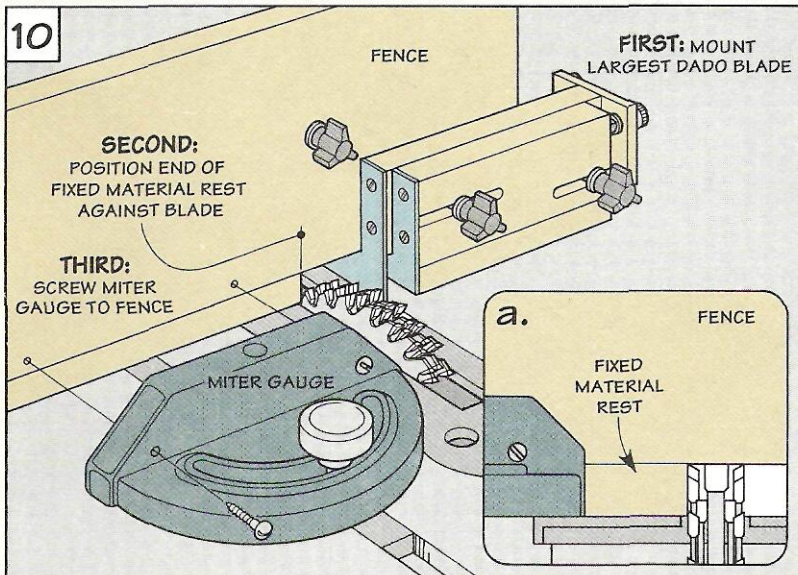

# Making Box Joints

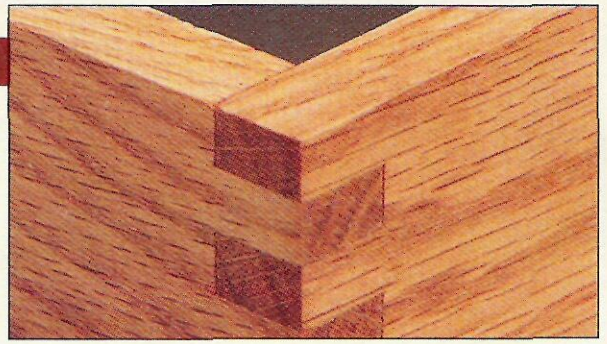

Basically, there are only two requirements for making box joints. Perfect spacing between the pins and slots. And getting the ends of the pins flush with the side of the adjoining piece, see photo above.

Using the micro-adjustable box joint jig shown on page 6 solves the first problem — cutting identically spaced pins and slots. (For more on adjusting the box joint jig, refer to Steps 2 and 3 below.)

**FLUSH PINS.** But to solve the second part of the problem (getting the ends of the pins flush with the sides) there are two things you'll need to take into account: the *length* of the pins and

## Step 1: Raise Blade.

To produce a box joint with the ends of the pins flush with the side of the adjoining piece, raise the blade to match the thickness of the workpiece. Note: This is the distance from the material rest to the top of the blade.

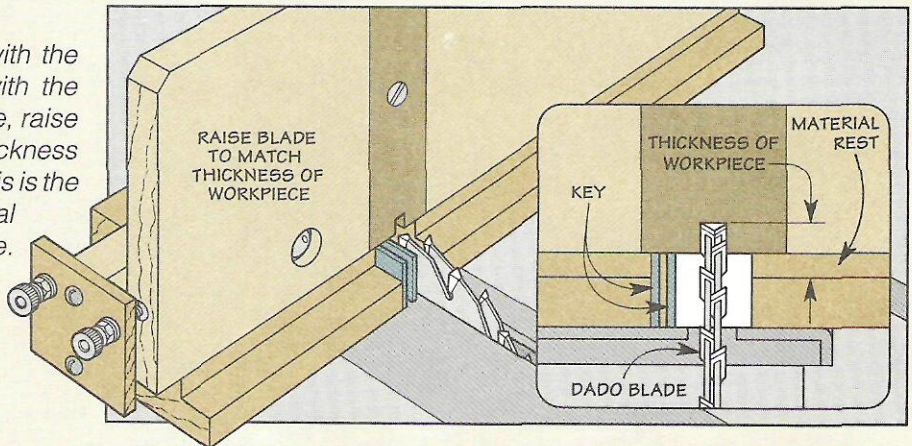

## Step 2: Set Width of Key.

Using a slot cut in a test piece, the key is adjusted to match the width of the slot. To do this, loosen the locking knobs and turn the back adjustment knob until the slot fits snugly over the key. Then tighten the outside locking knob.

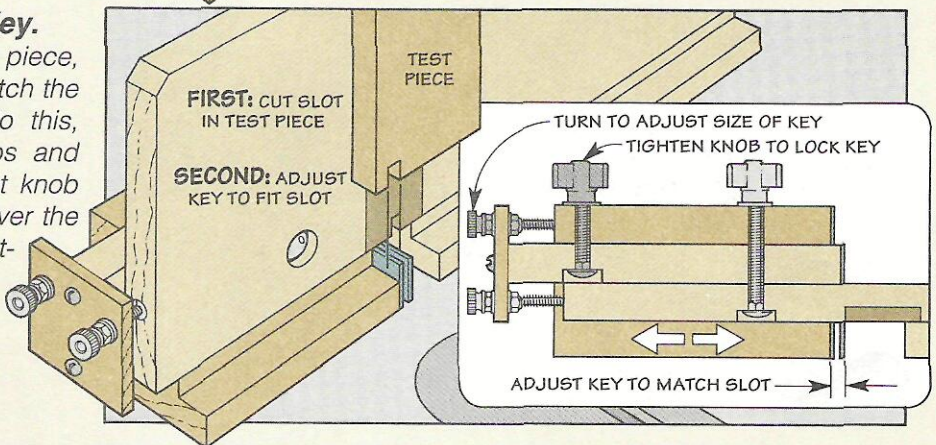

## Step 3: Adjust Spacing.

Now turn the front adjustment knob to set the spacing between the slots. After positioning the key the width of one slot from the blade, tighten the inside knob. Then make a test joint and readjust if necessary. Moving the key closer to the blade loosens the joint. Moving it away tightens the fit.

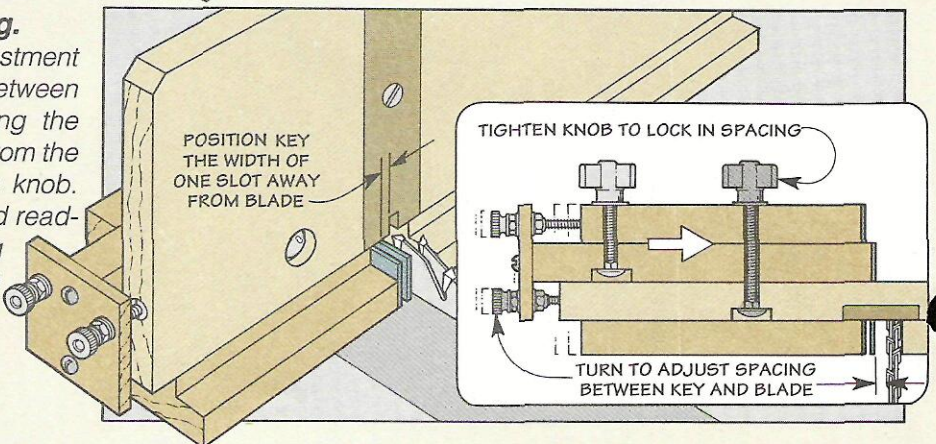

the *thickness* of the workpieces.

Ideally, the length of the pins matches the thickness of the workpieces. So start by checking that all the pieces are the same thickness. Note: While you're at it, "thickness" a few test pieces to use when adjusting the jig.

The next step is to determine the length of the pins (depth of cut). To do this, I use a test piece as a set-up gauge and raise the blade to match the thickness of the

piece, refer to Step 1 on page 12.

**APPEARANCE.** While it doesn't "make or break" the box joint, I like the look of a full pin (or slot) on the end of each piece. So after cutting each piece to length, I start with a board that's *wider* than what's needed. Then, after completing the slots, the extra width is trimmed to leave a full pin (or slot).

Note: The "waste" also comes in handy for keeping track of which edge to position against

the key, see Steps 4 through 6.

**TRIAL JOINTS.** Once the pieces are cut to "working" size, it's a good idea to make a trial joint. The goal is to slide the pins into the slots with a "friction" fit. This may require some readjusting of the jig to get a perfect fit. But the end result is worth the effort.

**MAKE JOINTS.** Now it's just a matter of cutting matching slots on each workpiece, see Steps 4 through 6 below.

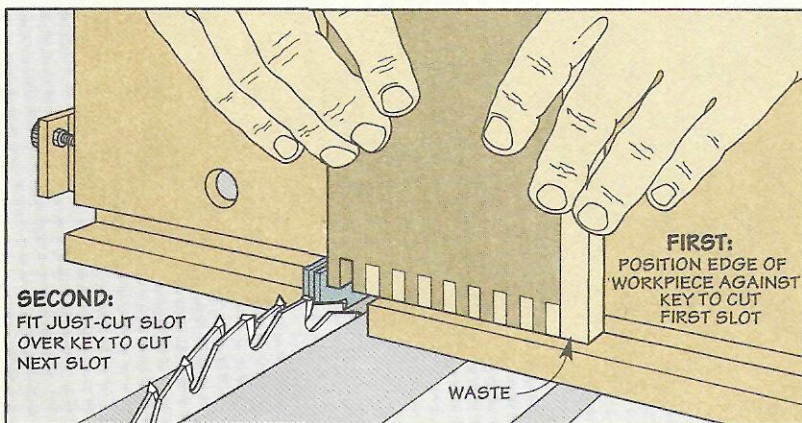

**Step 4: Cut Slots on End.**

With the edge of the workpiece against the key, cut the first slot. This creates a pin on the end of the piece. Then position the workpiece to cut each of the remaining slots by straddling the key with the slot that was cut last.

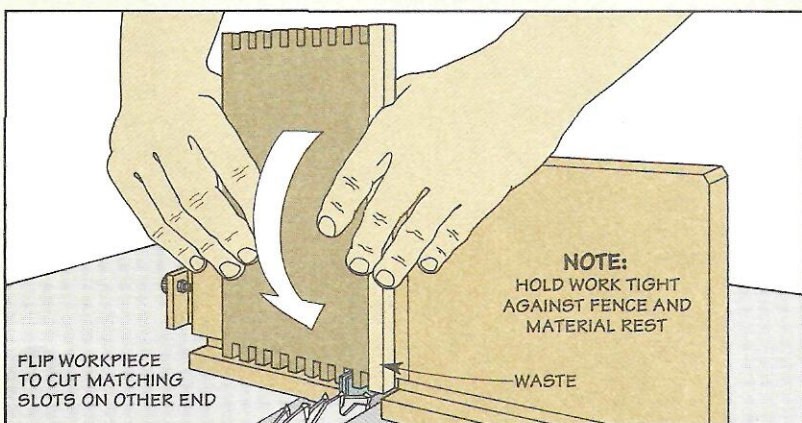

**Step 5: Cut Matching Slots.**

To cut matching slots on the opposite end, flip the workpiece so the waste edge is oriented to the same side. Then, with the work held firmly against the fence and the material rest, cut the rest of the slots using the same procedure as before.

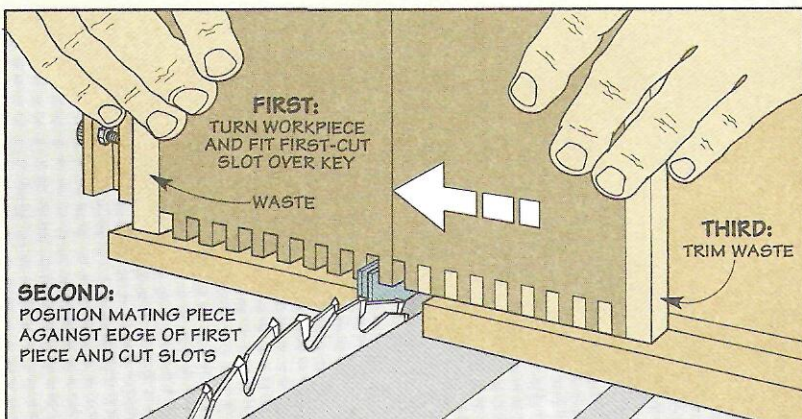

**Step 6: Form Mating Pins.**

To form pins that match the slots on the adjoining piece, use the first piece as a set-up gauge. Just turn it around so the waste edge is on the opposite side and the slot that was cut first fits over the key. After cutting this slot, set the first piece aside and complete the box joint.

# Sharpening Brad Point Bits

*A file and a two-step technique. That's all it takes to sharpen a brad point bit.*

**B**rad point bits are designed specifically to cut clean, accurate holes in wood. Like any other cutting tool, they work best when properly sharpened. Although the "business" end of a brad point bit may look a little complicated, it's easy to sharpen once you know how it works.

**COMBINATION BIT.** Basically, a brad point bit combines the best features of three different drill bits. It's like a hybrid of a spade bit, a Forstner bit, and a twist bit, see box below.

**POINT.** Like a spade bit, there's a sharp, tapered point for centering the bit on the workpiece. This prevents the bit from "wandering" off the centerpoint as you start the hole.

**LIFTERS.** After the point enters the wood, two cutting edges or "lifters" take over. Like the cutting edges on a Forstner bit,

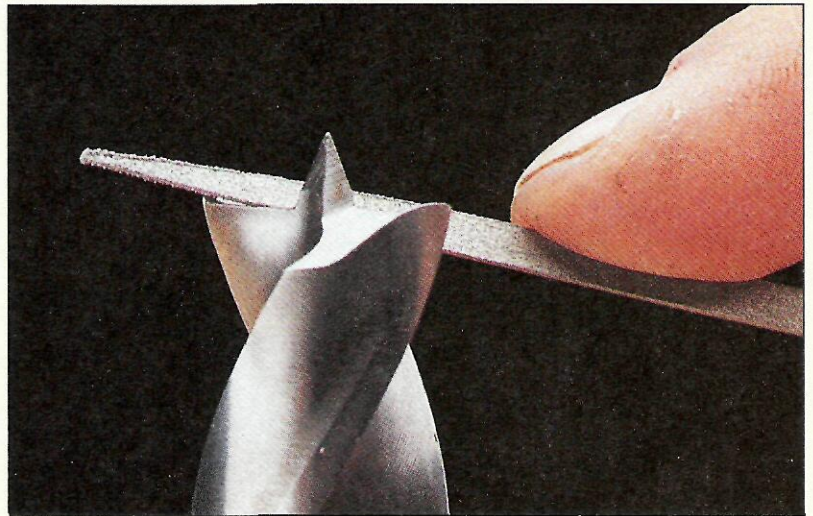

the lifters act like a pair of revolving chisels that shear off and lift out thin wood shavings.

**SPURS.** In addition to the lifters, some brad point bits also have two knife-edged "spurs." To produce a cleaner hole, these spurs score the wood fibers around the

perimeter of the hole.

**FLUTES.** As the hole is drilled, spiral flutes in the bit pull up and eject the chips from the hole like an auger. The basic idea is the same as a twist bit. Only the flutes are ground at a steeper angle so they eject the chips faster.

## SHARPENING

There's really nothing mysterious about sharpening a brad point bit. In fact, you can restore a sharp edge in less time than it takes to drill a hole with a dull bit. All it takes is a few strokes from a file. (For more information on selecting a file, see box on page 15.)

**CLAMPING JIG.** The first step is to provide a way to hold the bit securely in place while you're sharpening it. To do this, I use a simple clamping jig. This is just a scrap block of wood (I used a 2x4) with a shallow V-groove, see margin tip on page 15.

**SHARPEN LIFTERS.** With the bit extending about 1" above the block, the next step is to sharpen the lifters (cutting edges). The

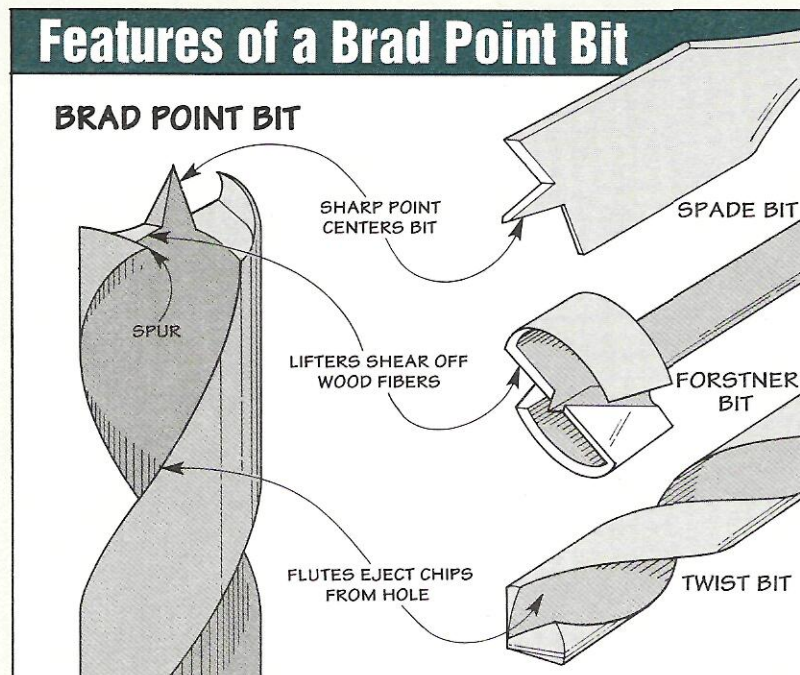

secret is to create a clean, sharp line along the edge. This requires filing the angled "flat" on the end of the bit, see Fig. 1.

**FILING ANGLE.** To determine the correct filing angle, just rest the face of the file on the flat. Once you've "found" the angle, push the file across the flat in a continuous motion. The trick is to file the flat without nicking the brad point or the spur.

To keep from rounding over the lifter, raise the file off the bit at the end of each stroke. Then find the angle again and repeat the filing process until the surface is shiny and flat.

The important thing is not to get carried away. The idea is to hone the cutting edge. Not reshape the bit. I usually keep track of the number of strokes I make on each lifter. This ensures that an equal amount of material is removed off each edge and that both lifters end up doing the same amount of work.

**SPURS.** If you have a brad point bit with spurs, the next step is to "dress" the *inside* of the spurs, see Fig. 2. Here again, find the angle with the file. Only this

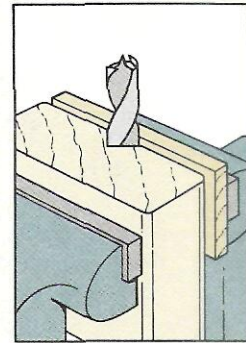
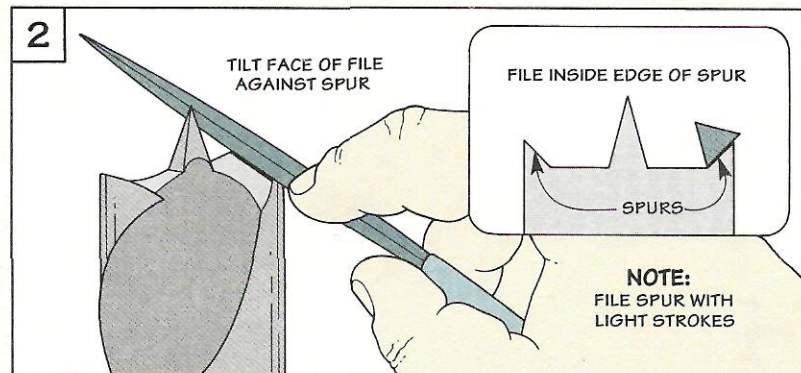
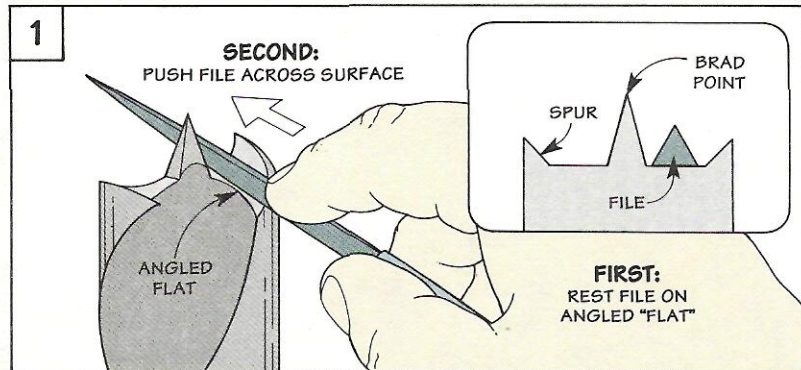

A scrap block of wood with a shallow V-groove holds the bit securely in place when sharpening.

time, tilt the file so the face is against the inside of the spur.

Now take one or two strokes until the surface is shiny and flat. A light touch here keeps from damaging the lifters that you've just sharpened. Note: *Don't* file the outside of the

spurs or you'll reduce the cutting diameter of the bit.

**POINT.** At this point, you may be tempted to sharpen the point. But it's easy to remove more from one side than the other. Since this throws the bit off center, I leave the point alone.

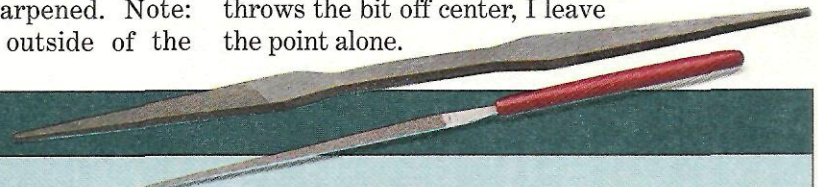

## Selecting a File

There are a number of different files available that can be used to sharpen brad point bits.

**MILL FILE.** For a large diameter bit without spurs, you can touch up the cutting edges with a flat mill file. But for spurred bits, a large file just gets

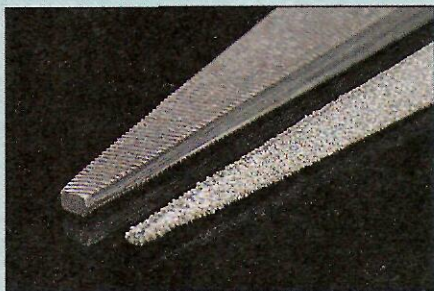

in the way.

**AUGER FILE.** One file that's especially suited to spurred bits is an auger file. This is a flat file with two tapered ends, see photo above. One end has teeth on each face while the opposite end has teeth only on the edges, see photo at left. This creates smooth or "safe" areas that let you file either the spur or the cutting edge without damaging the adjacent surface.

The only drawback is an auger file is too big to sharpen smaller diameter bits. To get between the point and the spur, a needle file is a handy tool.

**NEEDLE FILE.** This is a small steel file that not only gives you more control

when sharpening small bits. But it also lets you sharpen the lifters without accidentally nicking the spur or point.

The problem is these files don't work with all bits. To resist heat, some brad point bits are made of high speed steel. As a result, an ordinary steel file just doesn't "cut" it.

**DIAMOND NEEDLE FILE.** The solution is a diamond needle file, see photos above and at left. The diamond abrasive on the file does an excellent job of sharpening the hard steel of high speed bits. In fact, if I had to choose one file for all my brad point bits, I'd go with a diamond needle file. (For sources of files, see page 31.)

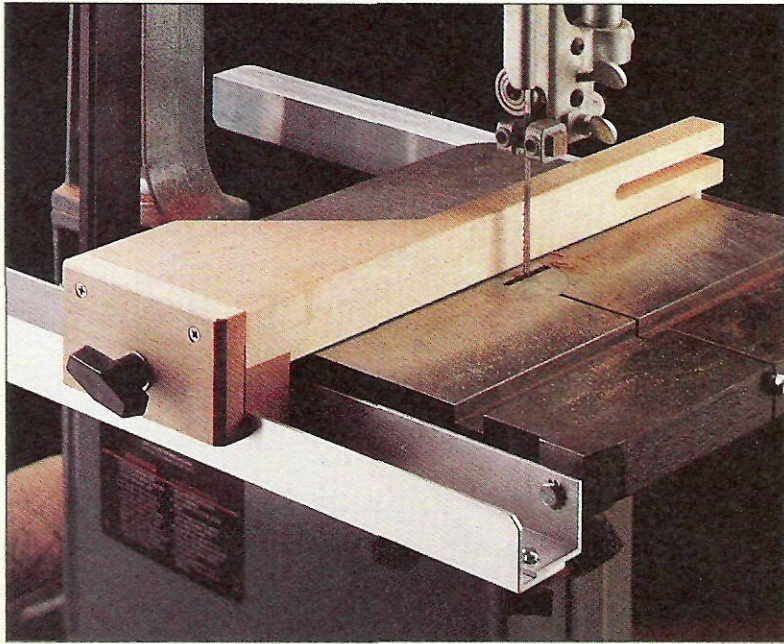

# Band Saw Fence System

*This unique fence system features a built-in clamping system, adjustable rails, and a pair of handy fence accessories.*

**H**ow many times have you clamped a scrap piece of wood to the table of your band saw as a fence? Then spent the next hour fiddling around with it just to get a straight cut.

The solution is simple — add a fence system. But this is an expensive option for most band saws. So I decided to build my own, see photo. The fence system is made up of two main parts: a wood fence and a set of metal rails.

**FENCE.** The fence supports the workpiece and determines the width (or thickness) of the cut. To make sure it stays in place after it's been positioned, there's a simple, but effective fence clamp, see photo A. Once it's clamped in place, the fence is rock solid — there's no side to side play whatsoever.

**ACCESSORIES.** There's a slot cut in the end of the fence to accept two optional accessories. One accessory is a simple block that acts as an adjustable stop for repeat cuts, see photo B. The other is a tall auxiliary fence that provides added support when resawing. (For more on this, see page 21.)

**RAILS.** The fence fits into a set of aluminum angle rails: a two-piece front rail and a single back rail. The two-piece front rail allows you to quickly and easily adjust the angle of the fence to get a straight cut, see photo C. (For more on adjusting the fence, see page 21.)

In addition to being adjustable, the rails are also designed so that you can easily lift off the fence whenever it isn't being used.



**A. Fence Clamp:** Built into this fence is a two-piece clamp that pinches the front rail and locks the fence in position.

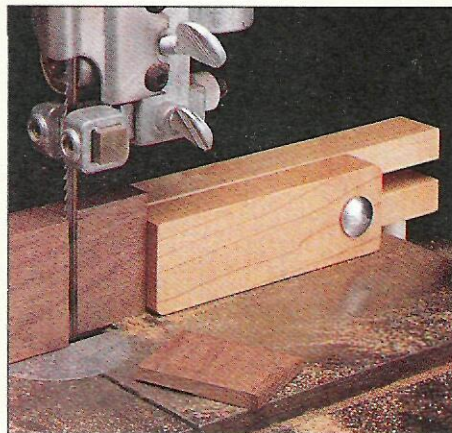

**B. Fence Accessories:** An adjustable stop block is one of two accessories that fit into a slot in the end of the fence.

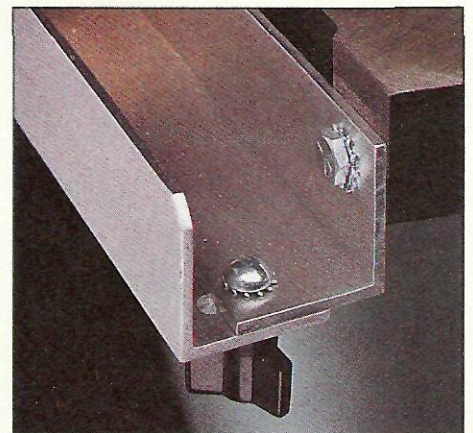

**C. Adjustable Rail:** The two-piece front rail is designed so you can adjust the angle of the fence to get a straight cut.



# SHOP PROJECT

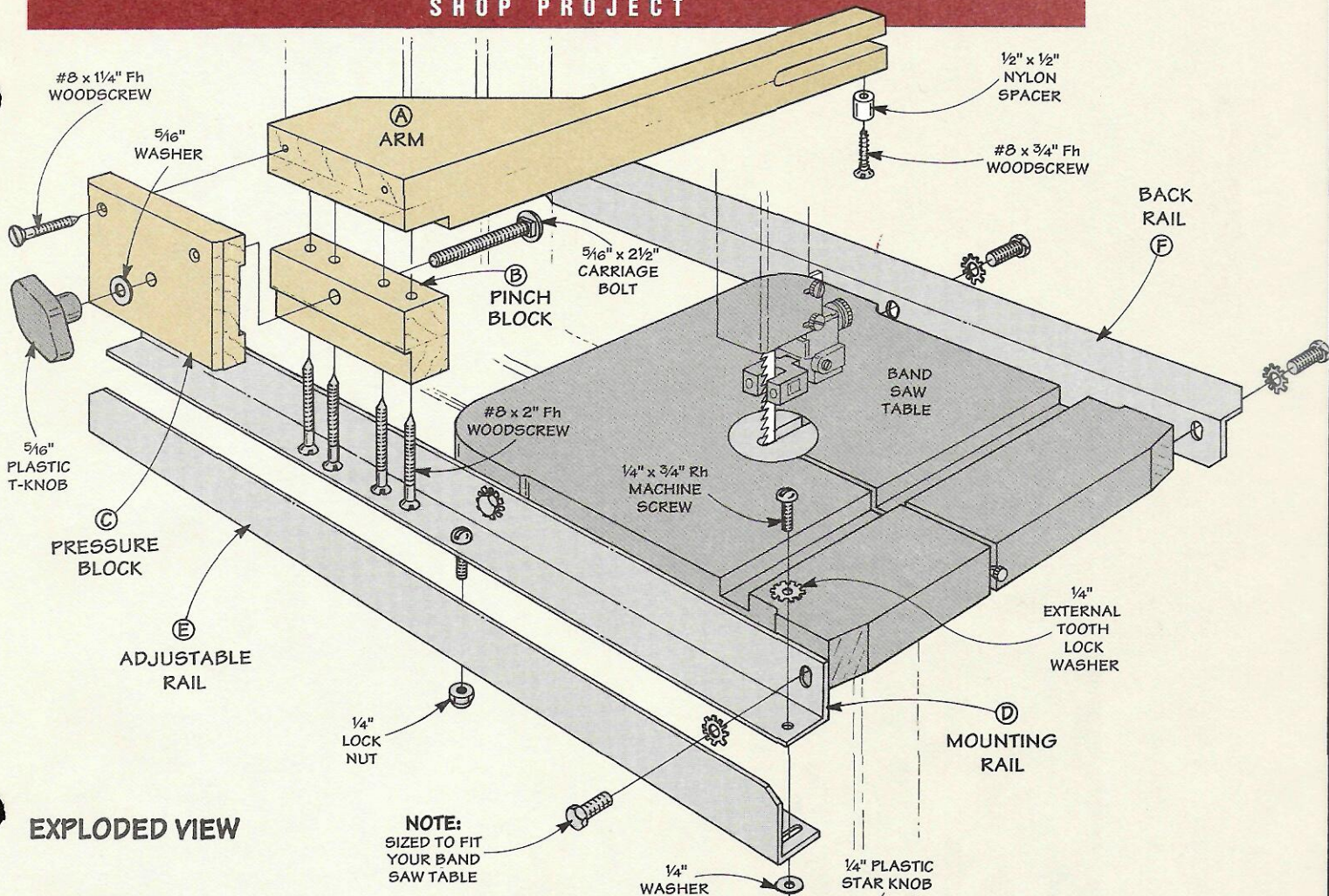

**EXPLODED VIEW**

**NOTE:**  
SIZED TO FIT  
YOUR BAND  
SAW TABLE

**NOTE:**  
SLOT IN ARM IS FOR  
OPTIONAL ACCESSORIES

## CROSS SECTION

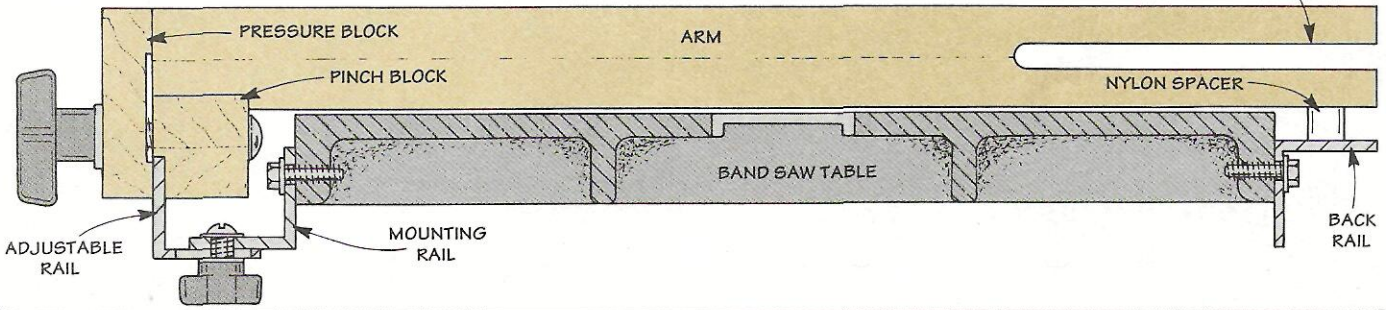

## Materials

- |                       |                      |
|-----------------------|----------------------|
| A Arm (1)             | 1 1/2 x 5 - 17 3/4   |
| B Pinch Block (1)     | 1 1/2 x 1 3/8 - 5    |
| C Pressure Block (1)  | 3/4 x 2 3/4 - 5      |
| D Mounting Rail (1)   | 1 1/2 x 1 1/2 - 24*  |
| E Adjustable Rail (1) | 1 1/2 x 1 1/2 - 24*  |
| F Back Rail (1)       | 1 1/2 x 1 1/2 - 24*  |
| G Aux. Fence (1)      | 5 x 17 3/4 - 3/4 ply |
| H Stop Block (1)      | 3/4 x 1 1/2 - 5      |
- \* slightly less than 24"

## Hardware

- (1) 1/8"-thick Aluminum Angle - 1 1/2" x 1 1/2"
  - (2) 1/4" - 20 x 3/4" Rh Mach. Screw
  - (1) 1/4" - 20 Lock Nut
  - (1) 1/4" External Tooth Lock Washer
  - (1) 1/4" - 20 Plastic Star Knob
  - (1) 1/4" Washer
  - (2) 5/16" x 2 1/2"-long Carriage Bolt
  - (2) 5/16" Washer
  - (1) 5/16" Wing Nut
  - (1) 5/16" Plastic T-Knob
  - (1) 1/2" x 1/2" Round Nylon Spacer
  - (4) #8 x 2" Fh Woodscrew
  - (2) #8 x 1/4" Fh Woodscrew
  - (1) #8 x 3/4" Fh Woodscrew
- \* a six-foot length of angle cut into three equal sections produces rails almost 24" long

# The Fence

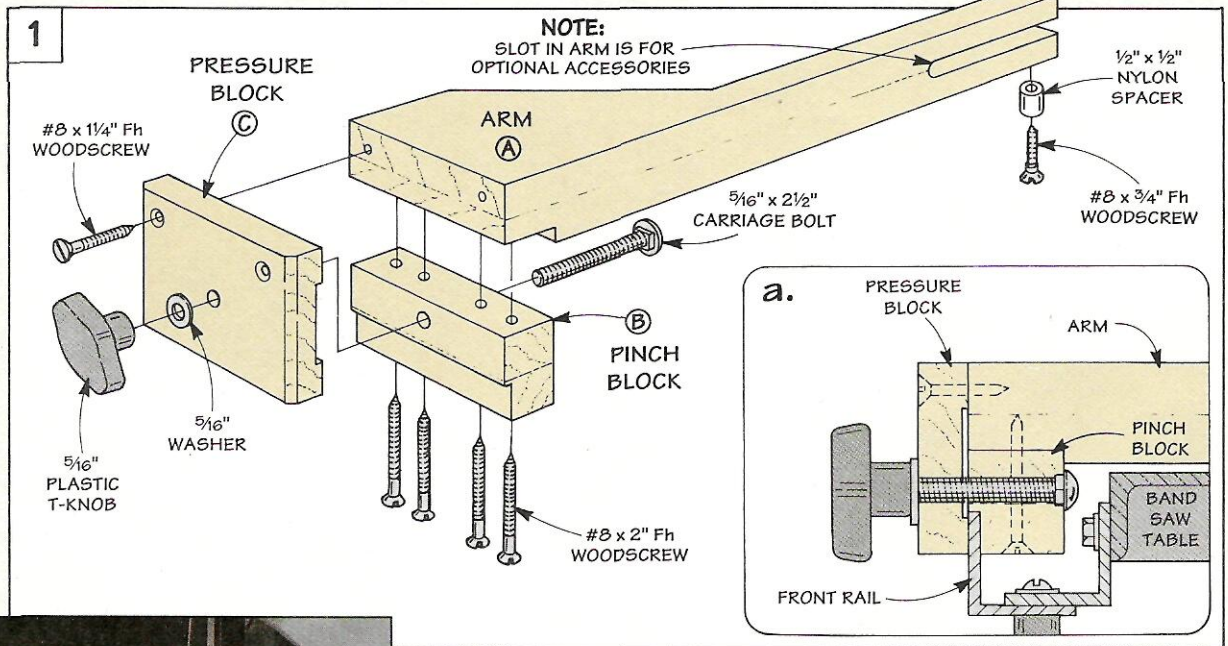

The "d"-shaped arm of the fence allows you to slide it all the way to the left to achieve a maximum cut.

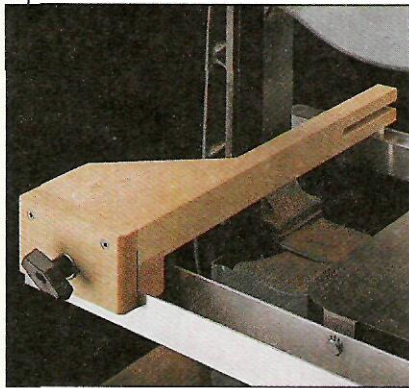

The heart of the band saw system is the fence, see Fig. 1. It consists of three parts: an arm, a pinch block, and a pressure block.

## ARM

I started work by making the arm. It's shaped like the letter "d" — wide at the front to provide a large clamping surface, and narrow at the end to clear the throat of the band saw, see photo above.

The arm (A) is made by gluing up two 5"-wide blanks of 3/4"-thick stock, see Fig. 2. (I used maple.) To determine the length of these blanks, measure the length (depth) of your band saw table and add 5". (In my case, they're 17 3/4" long.) After the glue dries, cut the arm to shape and sand the edges smooth, see Fig. 2.

**SLOT.** If you're planning on adding the fence accessories shown on page 21, now is the time to cut a slot in the arm, see Fig. 2.

**RABBET.** Also, to prevent the pinch block (B) from twisting when it's screwed to the arm later, I cut a 1/4"-deep rabbet in the front of the arm to "lock" it in place, see Figs. 1 and 2.

## PINCH BLOCK

The next step is to make the pinch block that fits in the rabbet you just cut, see Fig. 3. It forms the rear "jaw" of the clamp that

holds the arm in place on the front rail, refer to Fig. 1a.

To make the pinch block (B), start by gluing up two pieces of 3/4"-thick stock to make a long blank (about 8"). Then rip this blank to match the width of the rabbet (1 3/8"), see Fig. 3a.

**A LIP.** Next, to create a "lip" so the pinch block can ride on the front rail, a rabbet is cut on the edge of the blank, see Fig. 3a.

After the lip is cut, trim the pinch block to match the width of the arm (5") and screw it in place, see Fig. 3.

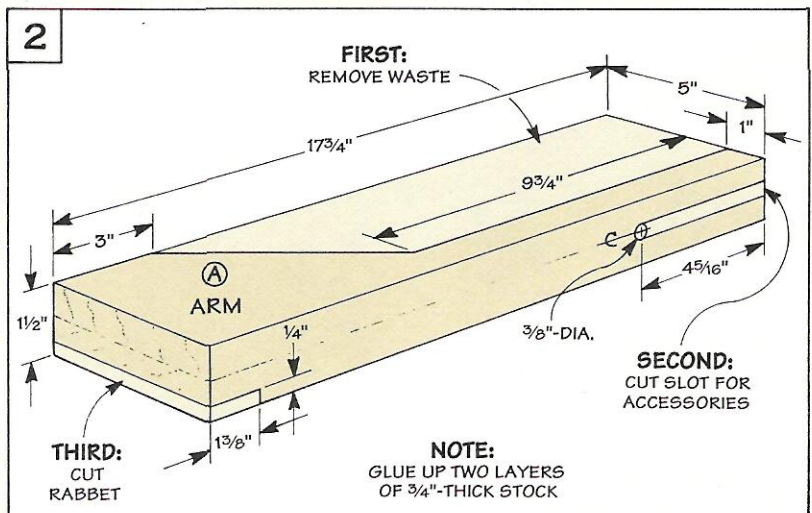

**PRESSURE BLOCK**

All that's left is to add the *pressure block (C)*, refer to Fig. 1. Since it's a short piece, I once again started with an extra-long blank. Cut this blank to match the combined height of the pinch block and arm ( $2\frac{3}{4}$ " ), see Fig. 4.

**SHALLOW GROOVE.** To help concentrate clamping pressure on the front rail, a shallow groove is cut in one face of the pressure block, see Fig. 4.

After the groove is cut, trim the block to match the width of the arm (5"), and chamfer the outside corners, see Fig. 4.

**CLAMP.** The pressure block is attached to the arm with two woodscrews. Clamping pressure is exerted by a carriage bolt and a T-knob (or a wing nut). (For sources of hardware, see page 31.)

The bolt passes through the pressure block and pinch block, refer to Fig. 1a. When the T-knob is tightened on the end of the bolt, it pinches the guide rail and locks the fence in place.

**TEMPLATE.** The tricky part is getting the screw and bolt holes to align in both pieces.

To solve this problem, I drilled holes in the pressure block *first*, see Fig. 4. Then I used the pressure block as a template to drill the matching holes, see Fig. 5.

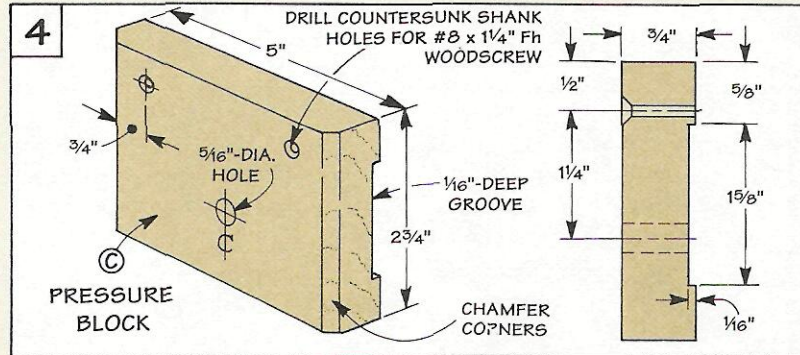
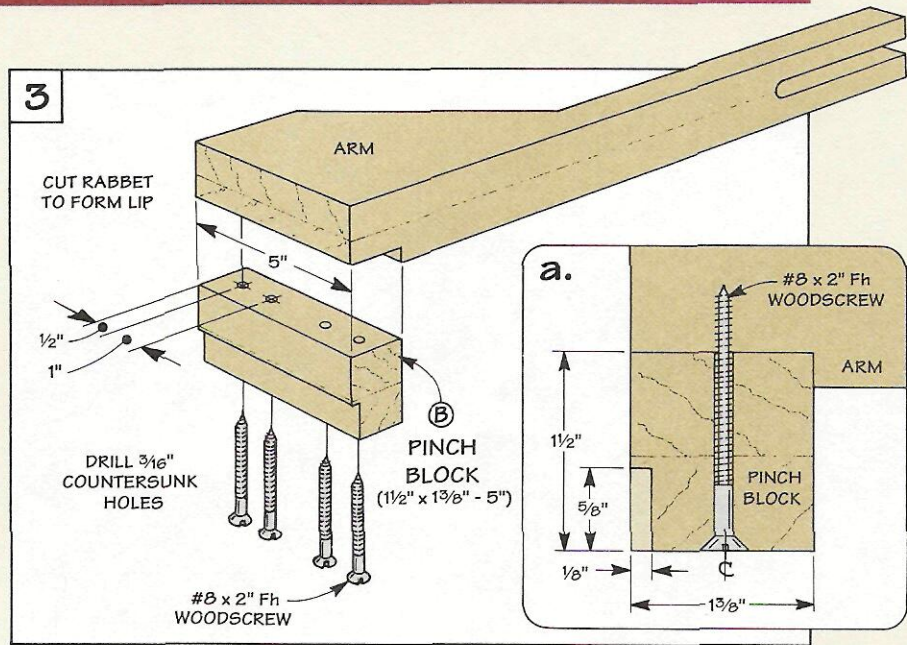

**ASSEMBLY.** After the holes are drilled, the fence can be assembled. To do this, drive the carriage bolt into the pinch block. Then, screw the pressure block to the arm and thread on the T-knob (or wing nut), refer to Fig. 1a.

**NYLON SPACER.** To complete the fence, screw a round nylon spacer to the narrow end of the arm, see Fig. 6. This spacer will ride on the back rail and support the fence when the arm doesn't rest directly on the saw table.

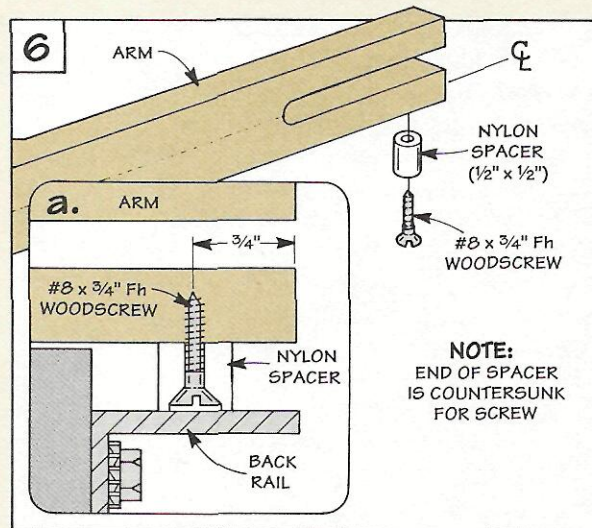
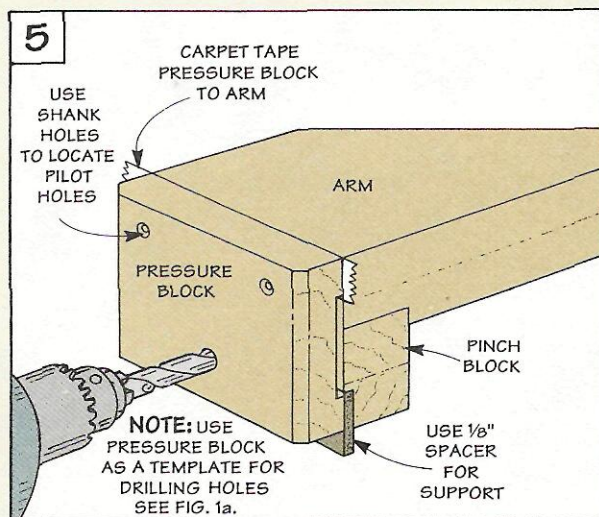

# The Rails

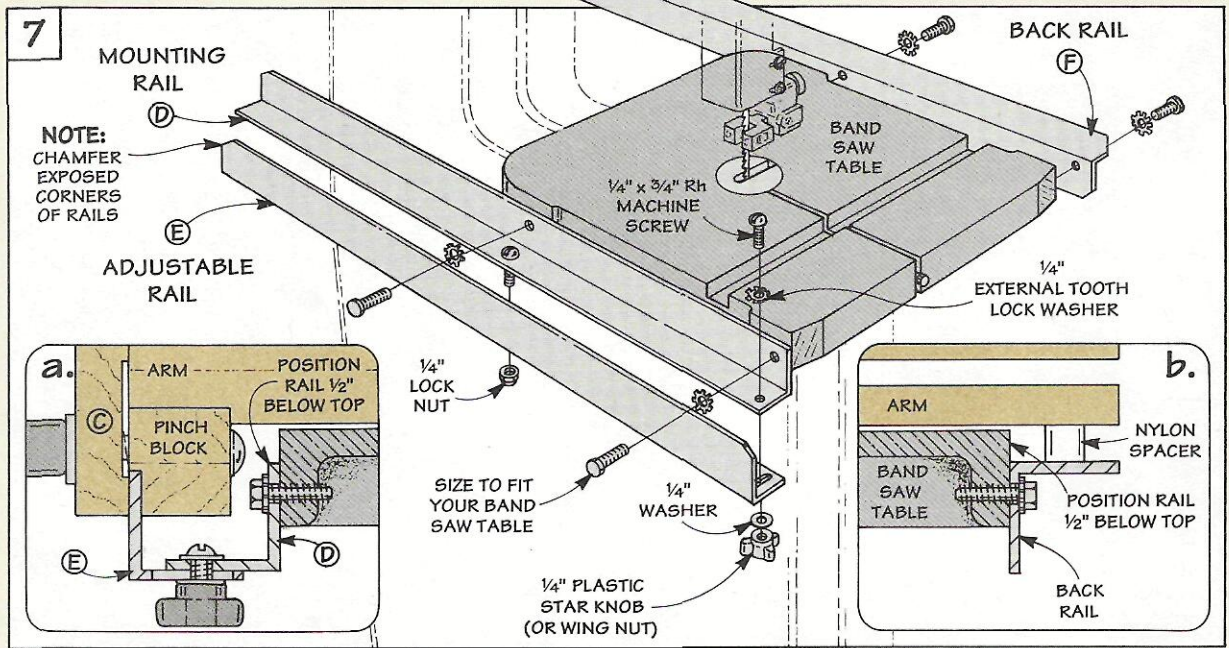

With the fence complete, work can begin on the rails: a two-piece front rail and a back rail, see Fig. 7.

**ALUMINUM ANGLE.** All three rail pieces are made from 1½" x 1½" aluminum angle (available at most hardware stores). I used a hacksaw to cut the rails from a single six foot length of angle (each piece is almost 24" long).

**FRONT RAIL.** The front rail consists of two pieces, see Fig. 7. A *mounting rail* (D) which attaches to the table of your band saw. And an *adjustable rail* (E) that pivots so you can adjust your fence to get a straight cut.

The pivot point is centered on the length of the rails. A slot on one end allows you to adjust the rail and "lock" it in position.

**SPACER BLOCK.** The tricky part is drilling the holes in both rail pieces so they align. The solution is to clamp a spacer block between the rails, see Fig. 8. Then lay out and drill the holes.

**MAKE SLOT.** Next, to create the slot in the adjustable rail (E), I drilled a series of holes and filed the slot smooth, see Fig. 8b.

**MOUNT RAIL.** To mount the front rail, two oversized holes are

drilled in the mounting rail (D) for bolts. These bolts thread into the pre-drilled holes in your table top, see Fig. 7. (Note: If your band saw doesn't have these holes, you'll need to drill them.)

The important thing is that you locate the rail so it's ½" below the top of the table, see Fig. 7. This ensures it won't interfere with the bar of your miter gauge, see Figs. 7 and 7a.

**BACK RAIL.** Once the front rail is bolted in place, the only thing left is to add the *back rail* (F), see Fig. 7. It bolts to the rear of the table to support the narrow end of the fence, see Fig. 7b.

All you need to do is drill two oversized mounting holes and bolt it to the band saw table.

**CHAMFER CORNERS.** Finally, file off the sharp exposed corners on the rail pieces, see Fig. 7.

An adjustable two-piece front rail and a single back rail provide support for the fence and allow you to compensate for "drift."

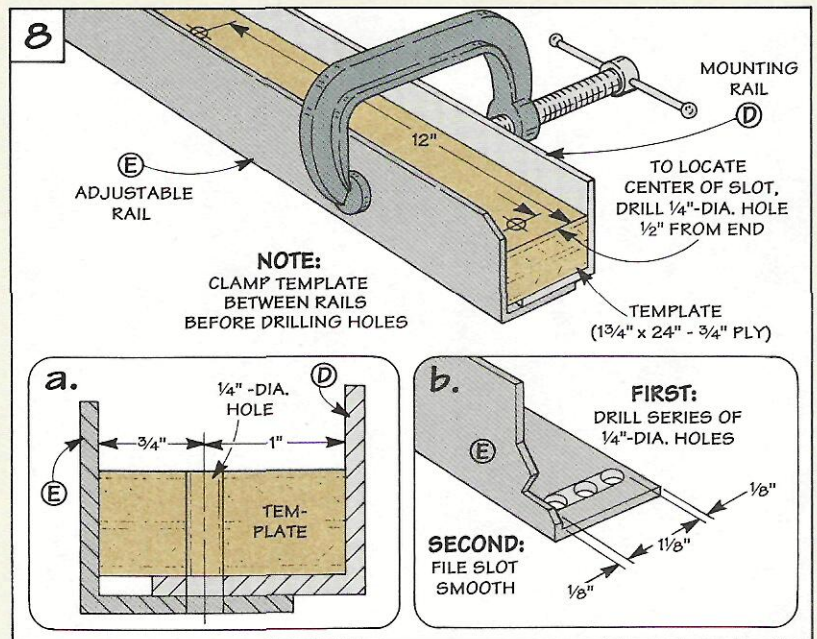

# Fence Accessories

There are two fence accessories that I find myself reaching for all the time. One's a tall auxiliary fence that makes resawing safe and simple, see Fig. 9. The other is an adjustable block that's handy for making stopped cuts (like cutting tenons), see Fig. 10.

**AUXILIARY FENCE.** The auxiliary fence (G) offers additional support to your workpiece when resawing. It's just a piece of plywood cut to match the length of the arm ( $17\frac{3}{4}$ " ), see Fig. 9.

This fence attaches to the arm with a bolt and a wing nut, see Fig. 9. To prevent your workpiece from catching on the bolt, counterbore the hole, see Fig. 9a.

**STOP BLOCK.** The stop block (H) is a piece of scrap hardwood with a hole drilled at one end for a carriage bolt. Locating the hole near one end allows you to flip the block and position it either close to the blade, or back by the end of the arm, see Fig. 10.

To complete the stop block, chamfer the two opposing corners of the block for sawdust relief, see Fig. 10.

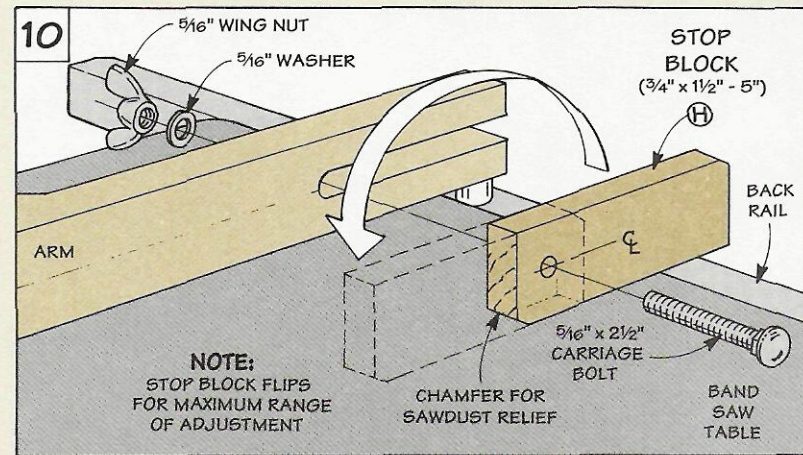
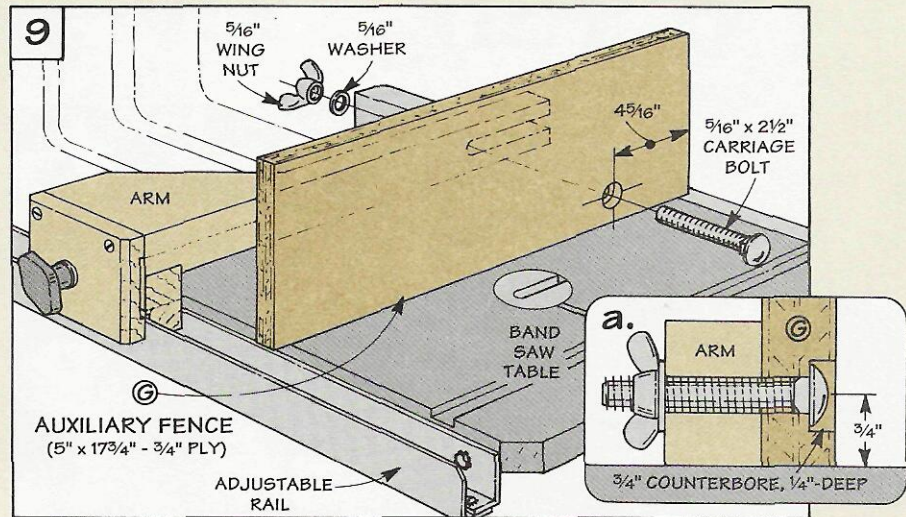

## Adjusting the Fence

The most unique feature of this fence system is its ability to *compensate* for drift. Drift is the tendency of the blade to "pull" one way or the other while cutting. This can be caused by using a dull blade, or a blade with uneven set.

The solution is to adjust the angle of your fence to match the pull or "drift."

**ALIGN FENCE.** The first step is to align the band saw fence to your miter gauge slot.

Start by positioning the fence next to the edge of the miter gauge slot and lock it in place. Then loosen the star knob on the adjustable rail (E), see Detail.

Next, pivot the adjustable rail until the arm of the fence aligns with the edge of the slot, and tighten the star knob.

**TEST CUT.** To check the fence system, I make a test cut. Start by standing a scrap piece of wood on *edge*, see Drawing.

Then position the fence to cut half its thickness and resaw the board. If the cut is straight, no further adjustment is needed.

**DRIFT.** If the cut isn't straight, you have a "drift" problem. To compensate for this, loosen the star knob on the adjustable rail and pivot the rail to match the angle of the drift, see Drawing.

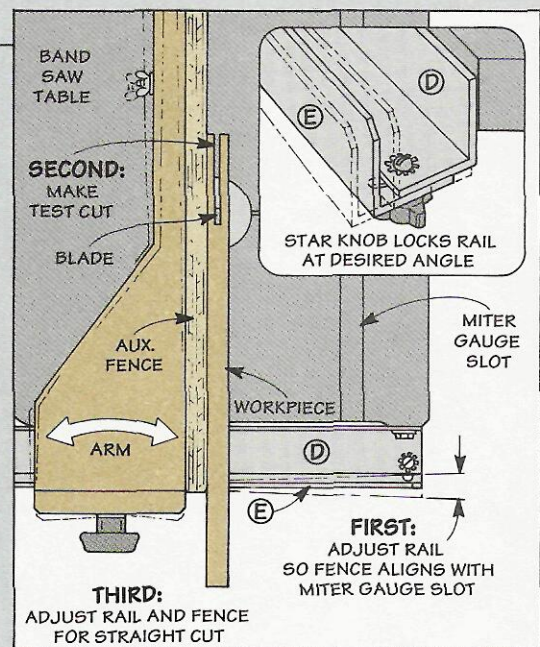

# Sliding Bevel Gauge

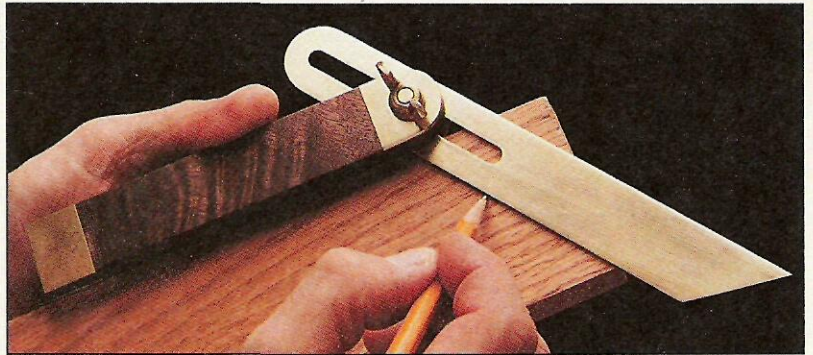
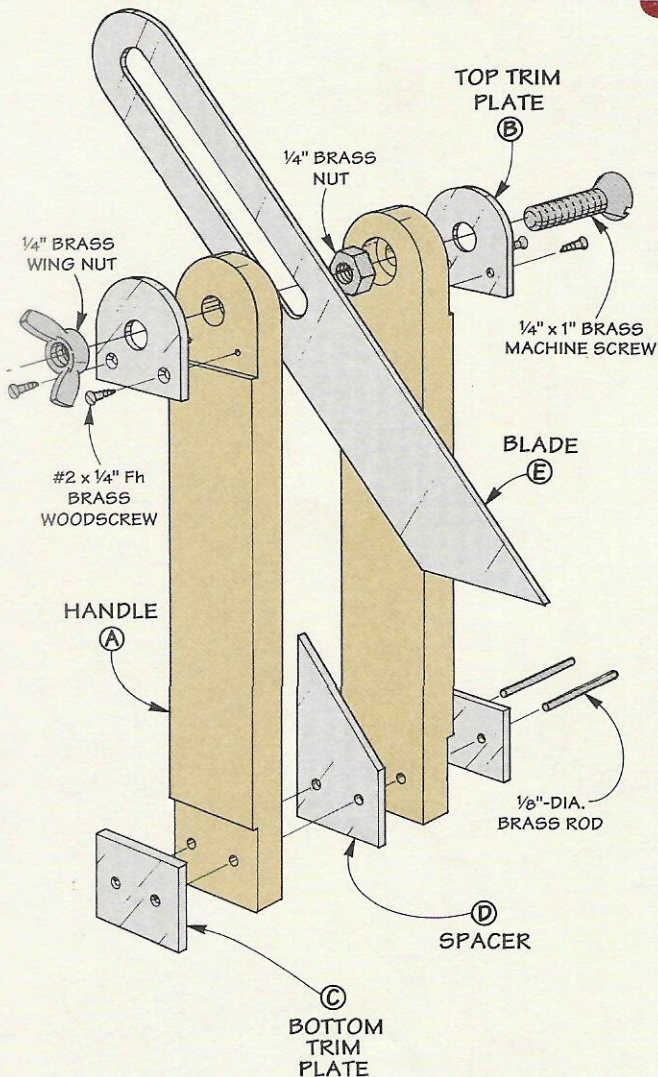

*How do you get a flawless fit between brass and wood? All it takes is a scrapwood jig and some simple techniques.*

**B**rass and wood. Two traditional materials for making hand tools. And the bevel gauge shown here is the perfect opportunity to combine these materials to make your own fine tool.

All you need are two small pieces of wood and a 1"-wide brass strip. (Brass is available at most hobby stores, or see page 31.)

The challenging part is getting an almost flawless fit between the brass and wood. To get a fit like this requires some special

techniques. (For more on this, see the boxes on following pages.)

## THE HANDLE

I started work on the bevel gauge by making the wood handle, see Drawing at left. Since brass can stain light colored woods when it's filed or sanded, I used walnut. But any dark hardwood will do.

To make the *handle* (A), first cut two  $\frac{3}{8}$ "-thick blanks to match the width of your brass strips (1") and  $5\frac{3}{4}$ " in length, see Fig. 1.

## Hardware

- (1)  $\frac{1}{16}$ " Brass Strip - 1" x 12"
- (1)  $\frac{1}{4}$ " Brass Wing Nut
- (1)  $\frac{1}{4}$ " x 1" Brass Machine Screw
- (1)  $\frac{1}{4}$ " Brass Nut
- (1)  $\frac{1}{8}$ "-Dia. Brass Rod 12"
- (4) #2 x  $\frac{1}{4}$ " Brass Screws

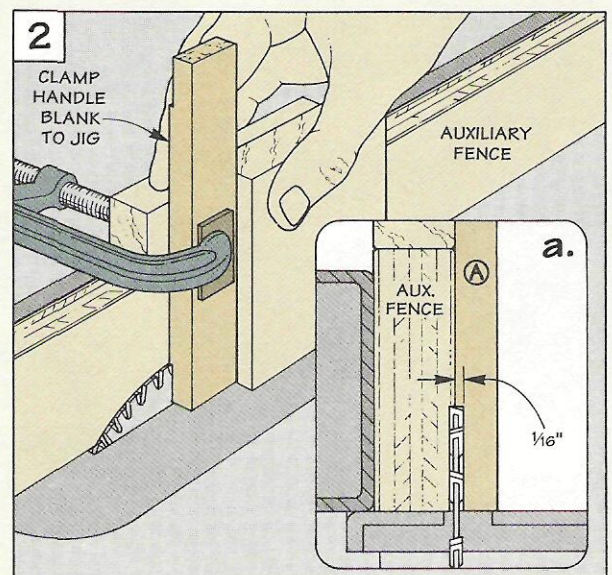
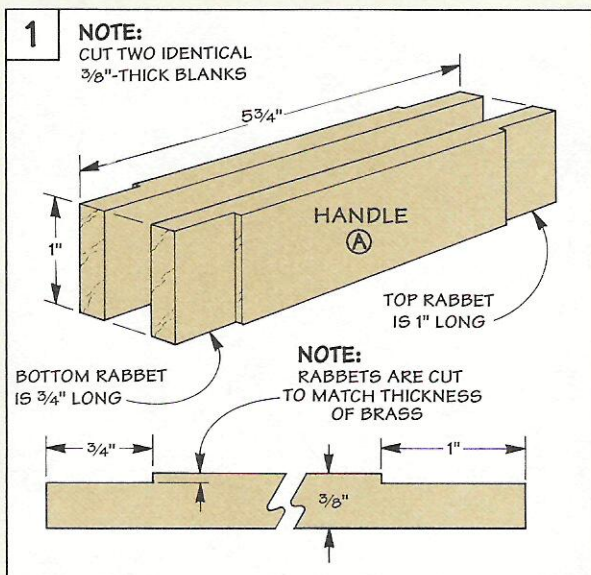

**RABBETS.** After these blanks are cut to size, shallow rabbets are cut on the ends to accept brass trim plates, see Fig. 1.

The depth of the rabbets is the same thickness as the brass strip ( $\frac{1}{16}$ "). The only difference is their length (height). The rabbets on the bottom end of each blank are  $\frac{3}{4}$ " long. But the rabbets on top are 1" long.

To cut these rabbets, I attached an auxiliary fence to the table saw. Then, to support the workpiece, I clamped it to a simple jig, see Fig. 2.

### TRIM PLATES

Once the rabbets are cut, the next step is to fit the *top* (B) and *bottom* (C) trim plates in the rabbets, see Fig. 3. All the brass parts (including the trim plates) are cut from a single 12" long brass strip.

The unusual thing is they're *not* all cut at once. Instead, the brass strip is first squared at one end. Then a trim plate is marked out and cut to rough length. Then the rough-sawn edge of the strip is squared up again, and the next plate is cut, see box below.

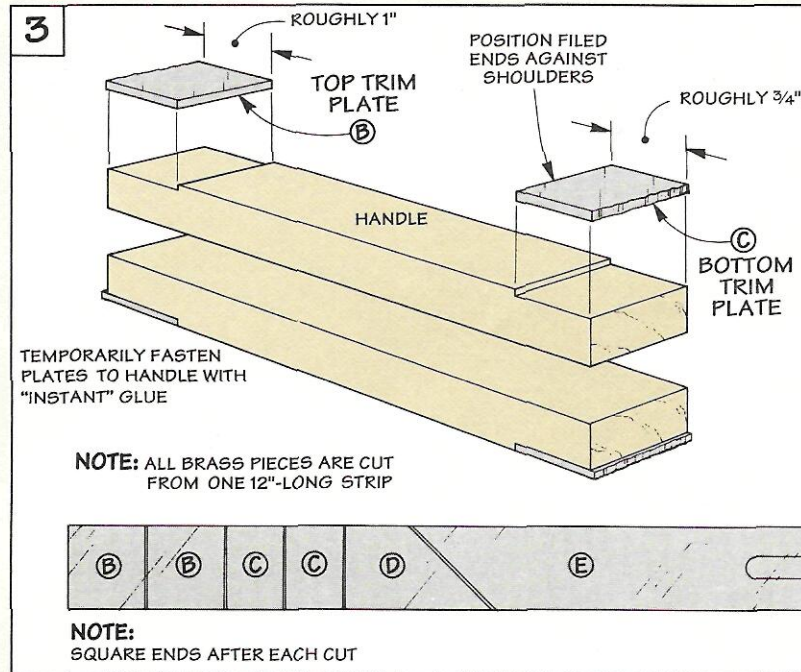

Cutting the pieces individually like this ensures that each trim plate will fit tight against the shoulder of the rabbet.

**FITTING THE PLATE.** But before you can cut the plates to length, the brass strip needs to be flattened, see box below. Then, one end of the strip is squared and cut to rough length, see Fig.

3. Later, it will be filed flush with the end of the handle.

**GLUE TRIM PLATE.** After the plate is cut to rough length, I use "instant" glue to temporarily hold it in the rabbet. Instant glue isn't strong enough to hold the brass strip in place permanently. Later, it will be attached permanently with screws or rivets.

## Fitting Brass

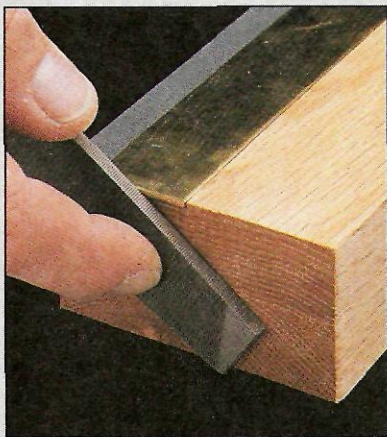

Fitting brass to wood is easy with this simple jig. First, the brass strip is flattened. Then, one end is squared with a smooth mill file.

■ For a brass strip to fit tight in a rabbet, it has to be flat and square. The problem is they aren't manufactured this way, see Detail.

To solve this, I use a simple jig, see Drawing. It's just a block of wood with a shallow rabbet cut in it for the brass strip.

**FLATTEN FACE.** To flatten the brass, glue a piece of 120 grit silicon carbide sandpaper in the rabbet. Then slide the *entire* strip back and forth until it's flat.

**SQUARE EDGE.** Next, to square an end, extend the strip past the end of the jig and clamp it. Then using the end of the jig as a guide, file the end square, see photo.

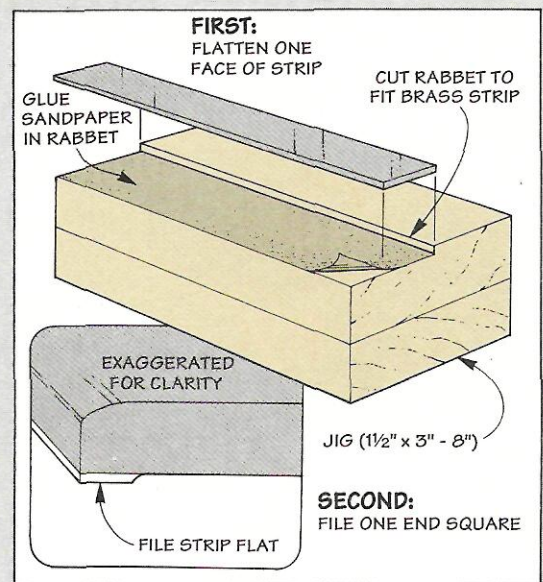

# Assembly

With all the trim plates glued in place, the next step is to attach the two 1"-long top plates *permanently* to the handle blanks, see Fig. 4.

**TOP PLATES.** Each top trim plate (B) is screwed to a handle blank with two #2 x 1/4" solid brass woodscrews, see Fig. 4a.

Since I didn't want the slots of the screw heads to show, I countersunk the holes *slightly* so the slots are just above the brass strip, see margin tip at left, and Fig. 4a. Then I filed the heads off flush with the brass strip.

**BRASS SCREW.** The next step is to drill a hole through the top trim plates and handle blanks, see Fig. 4. This hole is for a brass machine screw (added later) that will help hold the blade in place.

To make sure the holes in both handle blanks align, carpet tape them together and then drill a 1/4"-dia. hole, see Fig. 4. (Note: Once the hole is drilled, separate the blanks and remove the tape.)

To lock the machine screw in place, it's threaded into a brass nut, see Fig. 5. To create a

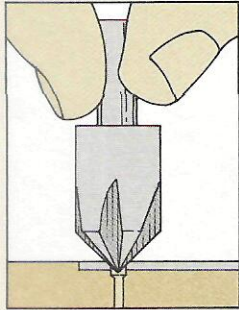

A simple way to keep a countersink bit from chattering, is to turn it by hand.

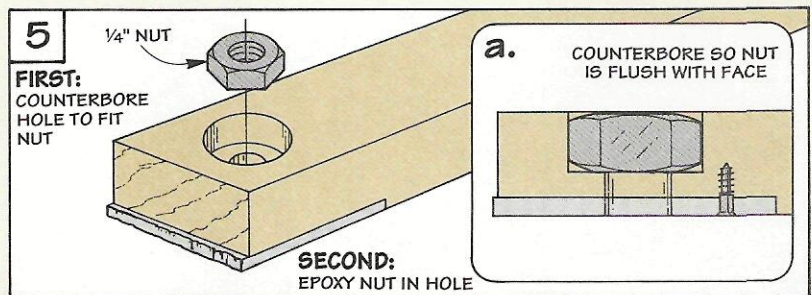
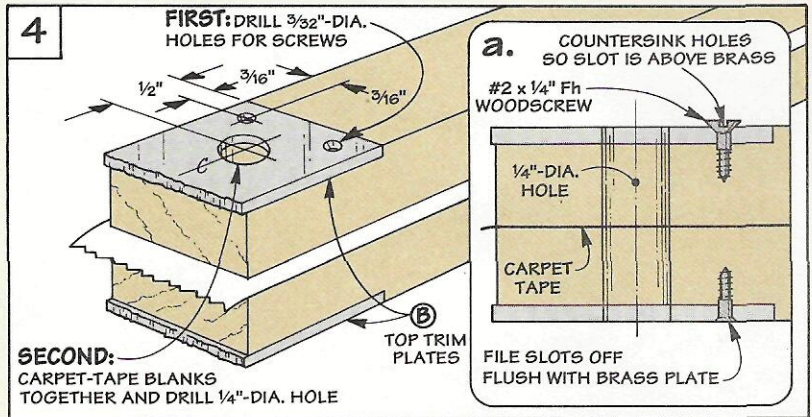

“pocket” for the nut, I used a Forstner bit to drill a counterbored hole in the *inside* face of one of the blanks, see Fig. 5a. Then I epoxied the nut in place.

**SPACER.** Now you can begin work on the other end of the han-

dle. The handle blanks are separated at the bottom by a spacer, see Fig. 6. The spacer provides clearance for the blade that's added later. And the mitered end acts as a stop for the mitered end of the blade.

## Riveting Brass

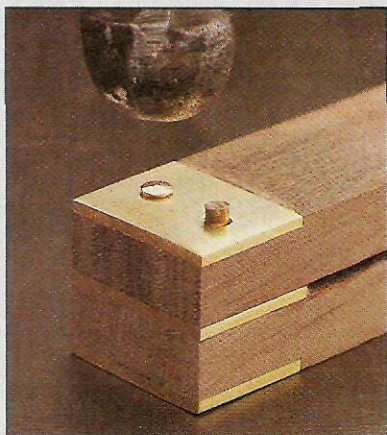

Rivets made from brass rod “draw” the handle pieces tightly together when the ends are peened over like a mushroom.

■ Riveting brass is a simple three step process. All it takes is a brass rod and a little patience.

**DRILL HOLES.** The first step is to drill countersunk holes the same diameter as your brass rod, see Drawing.

**CUT RIVETS.** Then cut two pieces of brass rod to length so they extend about 1/16" “proud” on both sides, see Drawing.

**PEEN RIVETS.** Now, to lock the plates in place, peen the rivets. The idea is to “mushroom” the ends so they completely fill the countersinks, see photo at left. When you're done, file the heads flush with the brass plates.

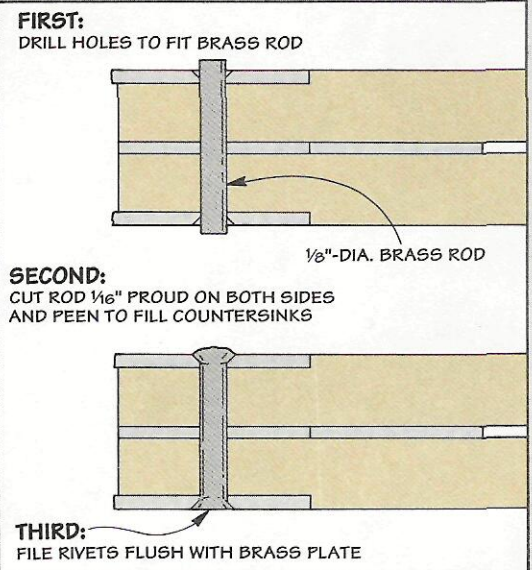



To make the *spacer (D)*, start by squaring up the end of the remaining length of brass strip. Then measure over  $\frac{3}{4}$ " and cut a 45° miter, see Fig. 6. After the spacer is cut to size, file the mitered edge smooth.

**GLUE UP HANDLE.** To ensure the spacer will glue up tight between the handle blanks, you'll need to flatten *both* faces of the brass strip (you've already flattened one side).

Once both faces of the spacer were flat, I glued it between the blanks and used a simple trick for alignment, see margin tip.

**RIVET HANDLE.** Now the bottom of the handle can be joined together *permanently*. What you have here is basically a "sandwich" of brass and wood. Since screws won't "draw" all the pieces together, you'll need a different technique.

The solution is simple, I rivet the pieces together, see Fig. 6a and box on page 24.

The rivets are just short pieces of  $\frac{1}{8}$ "-dia. brass rod (available at most hobby stores). The ends of the rivets are "peened" over to

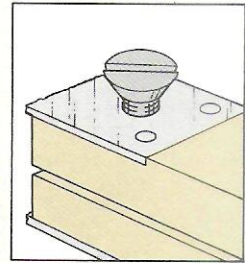
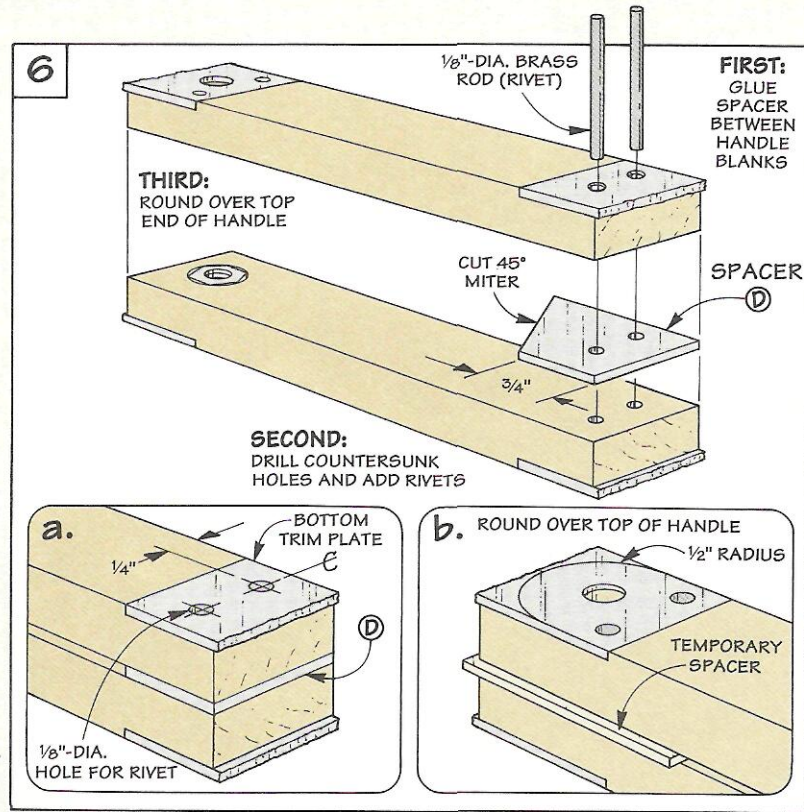

To align the top of the handle, insert a machine screw as a simple indexing pin.

lock the pieces tightly together.

**SHAPE HANDLE.** Now that the bottom of the handle is riveted together, both ends of the handle can be shaped.

First, a round-over is sanded on the top of the handle, see Fig.

6b and the box below. Note: To prevent the "open" end from flexing, insert a thin spacer between the handle blanks.

Finally, the bottom trim plates are filed flush with the bottom of the handle.

## Shaping Brass

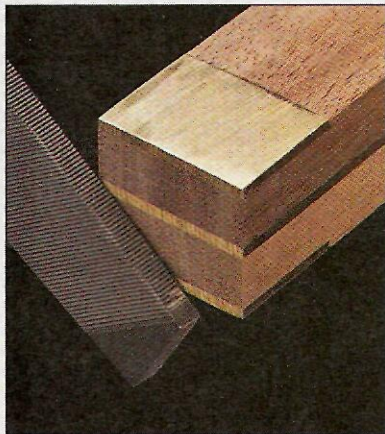

Shaping the ends of the handle is easy. You can use a smooth mill file (as shown), or a drum sander in a drill press.

There are two basic ways to shape brass: filing and sanding.

**FILING.** You can use a mill file to shape brass, see photo. This works well, but takes time.

**SANDING.** The other option is to sand the brass. A belt-disc sander works great. But it can remove stock too quickly and damage your work.

**DRUM SANDER.** I prefer to use a drum sander in a drill press, see Drawing. It takes the material off slower, but that's OK. This way I can sneak up on the shape. Note: When you're done sanding, switch to a file to smooth the radius at the top of the handle.

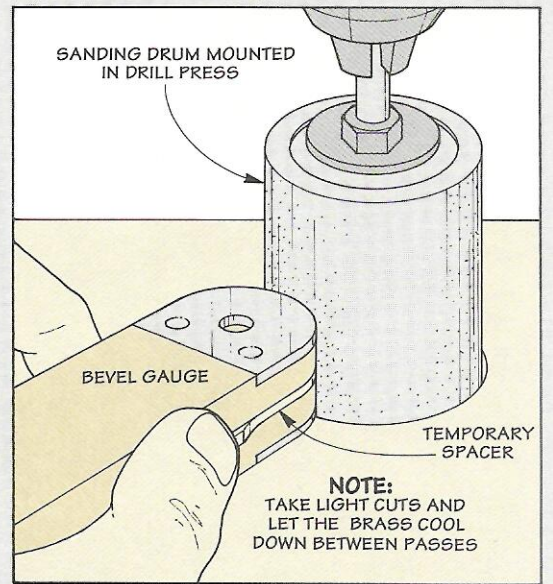

# The Blade

After shaping and filing the handle, the next step is to make the blade (E) from the remaining brass strip, see Fig. 7.

Since the end of this strip is already mitered (from cutting the spacer earlier), all you have to do is file the miter smooth and round over the other end, see Fig. 7.

**FIT BLADE.** For the blade to fit in the slot of the handle, you'll need to flatten both faces (just like you did for the spacer).

**SLOT.** After fitting the blade, a slot is cut in one end, see Fig. 7. (The technique I used is shown in the box below.) The slot allows the blade to slide and pivot to any angle. A brass machine screw will pass through this slot and lock the blade in place.

**COUNTERSINK.** With the blade complete, the last step is to countersink the hole in the handle to accept the brass machine screw, see Fig. 8 and margin tip at left.

**FINISH.** Finally, to get a satin finish on the brass and wood, I use a simple process, see box on page 27. When it's smooth, add the blade, screw, and wing nut.

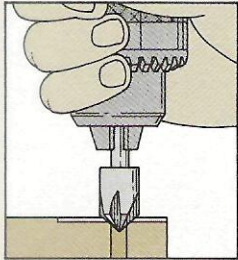

To countersink a large hole, I insert the bit in a drill press and turn the chuck by hand.

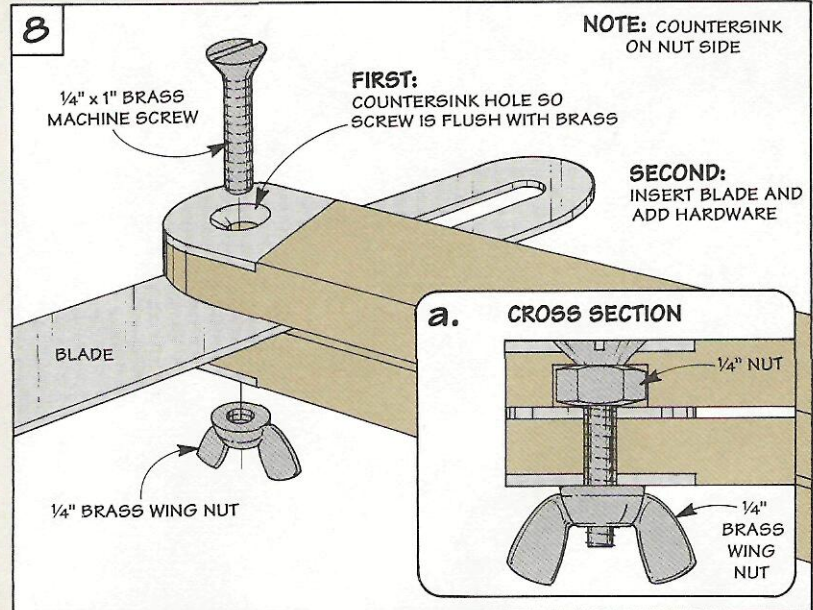
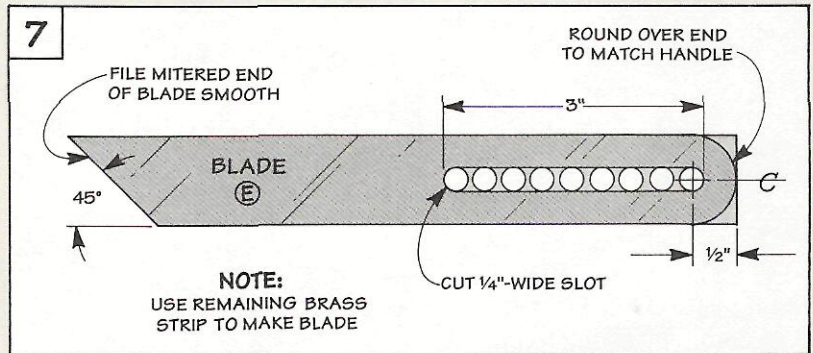

## Slotting Brass



Cutting a slot in brass is as simple as drilling a series of non-overlapping holes (as shown), then filing the slot smooth.

There are two simple steps to cutting a slot in brass — drilling and filing.

**DRILLING.** To drill holes in brass, you'll need a secure way to hold the brass strip. One way to do this is to use the same jig you used for filing, see photo.

But the most important thing is that you drill *non-overlapping* holes. If you try to overlap them, the bit can catch and ruin the brass.

**FILING.** After the holes are drilled, I use two files to clean out the slot. A round file to remove the "web" between the holes, see Fig. 1. And a flat mill file to file the slot straight, see Fig. 2.

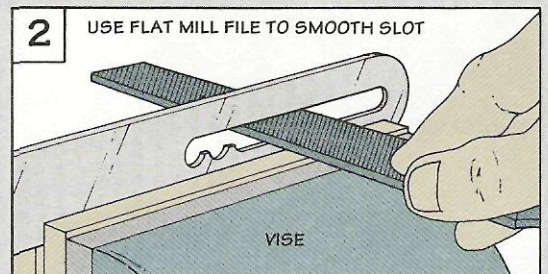
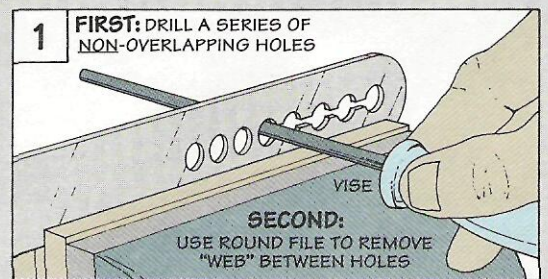

# Using a Bevel Gauge

## LAYING OUT AN ANGLE

A sliding bevel gauge is frequently used to lay out an angle directly on a workpiece (such as a bevel or taper).

**A PROTRACTOR.** A quick and easy way to do this is to use a protractor, see Fig. 1. Just loosen the wing nut, set the blade to the desired angle, and lock it in place.

Once you've set the angle of the gauge, position it on your workpiece and lay out the angle, see Fig. 2.

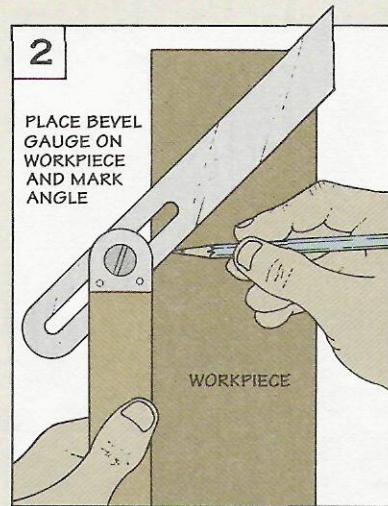
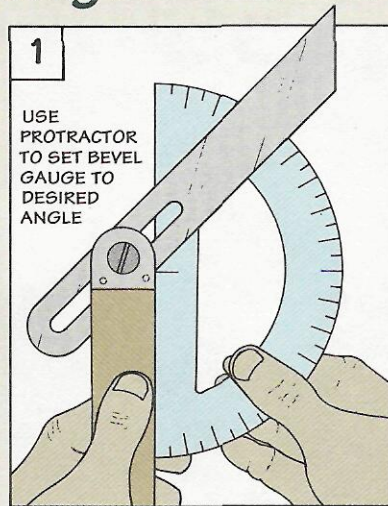

## DUPLICATING AN ANGLE

A bevel gauge is also handy when you need to cut a workpiece to match another.

**SET ANGLE.** To set the gauge, hold the bevel gauge in one hand and the workpiece in the other. Then adjust the blade to match the workpiece, see Fig. 3.

**TRANSFER ANGLE.** After the gauge is set, you can transfer the angle. Simply position the gauge and set the blade (or miter gauge) to the same angle, see Fig. 4.

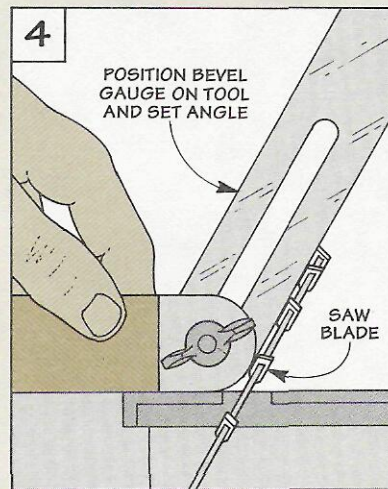
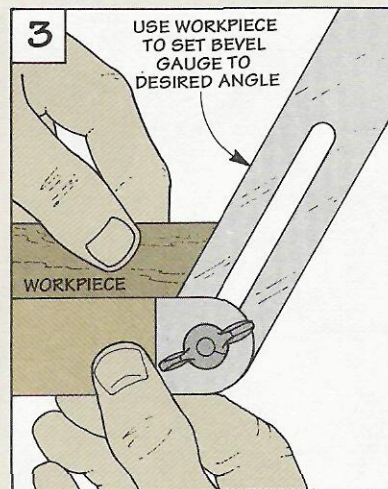

## Finishing Brass

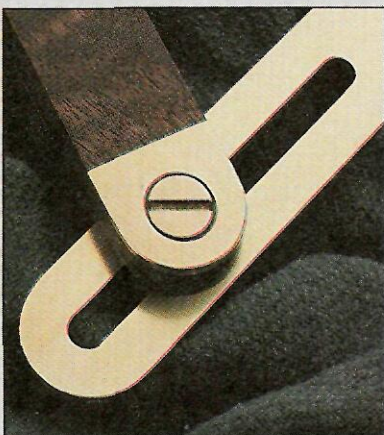

To get a satin smooth finish on both brass and wood, I sand with progressively finer grits of sandpaper. Then buff with steel wool.

■ Finishing brass to a soft luster is easy. It's just a matter of sanding with silicon carbide sandpaper, see photo. I start with 120 grit, and go to 240, 400, and 600. Then buff with 0000 steel wool.

**METAL FILINGS.** The only problem with sanding brass is it creates tiny metal filings that can scratch the project, see Drawing.

**PAPER TOWELS.** A solution is to set the project on a paper towel or cloth. Note: Use a fresh piece when you turn the project over so filings won't scratch the brass.

**FINISH.** Finally, to seal the wood and brass, I wipe on a couple coats of tung oil.

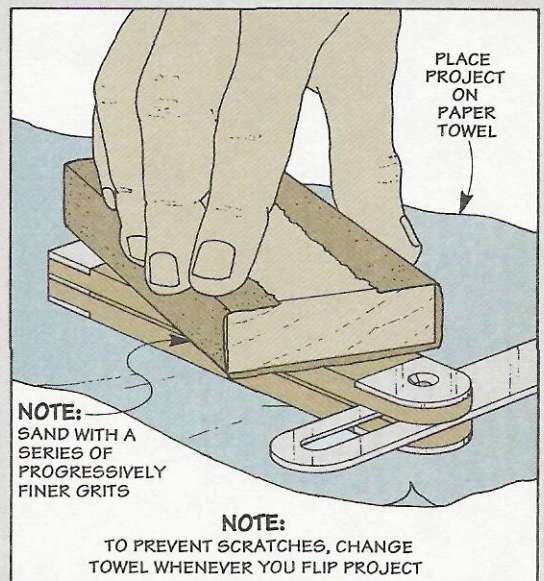

# Shop Solutions

## Dust Collector

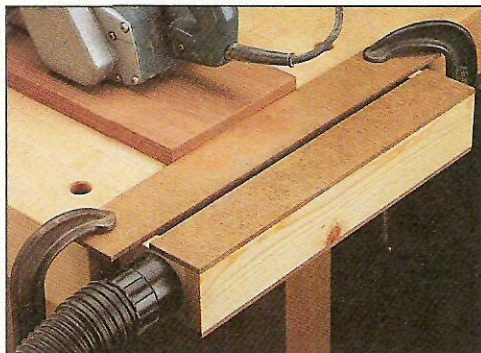

■ I have an older belt sander that doesn't have a dust bag attachment. To help reduce the amount of dust in the shop, I built a "mini" dust collector that clamps to my workbench and connects to my shop vacuum, see photo.

**VACUUM SLOT.** A narrow slot in the top of the collector allows the vacuum to pull dust out of the air. The slot creates a thin wall of suction that draws down the dust into the collector as it comes flying out of the back of the sander.

**CONSTRUCTION.** The dust collector is basically a box with  $\frac{3}{4}$ "-thick *sides* and *ends*. And a *top* and *bottom* made of  $\frac{1}{4}$ "-thick Masonite, see Drawing.

To create the vacuum slot, the top is made in two pieces, that are

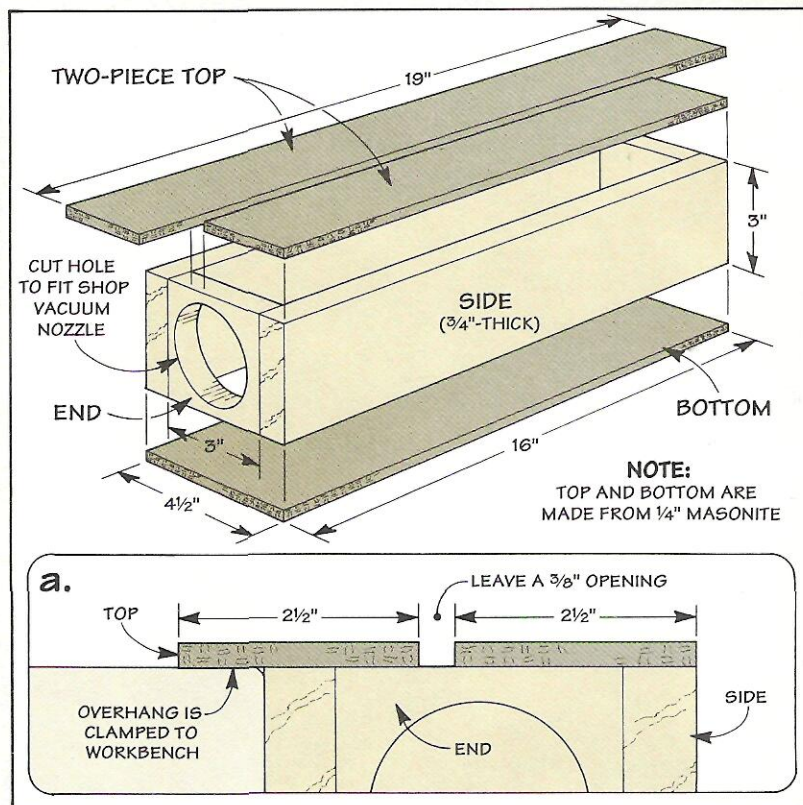

spaced  $\frac{3}{8}$ " apart. I made one of the top pieces oversized so it can be clamped to the end of my bench, see photo above.

This also allows the dust collector to serve as a stop to keep the workpiece in place while I'm run-

ning the sander over it.

Before you glue the parts of the collector together, cut a hole in one of the ends to fit the nozzle on your vacuum hose.

*Harry Svec  
Ames, Iowa*

## Quick Tips

■ Like many woodworkers, I use the shop floor when assembling larger projects. But the floor in my shop is uneven and can throw the project out of square.

To create a flat assembly area, I lay a solid-core door on the floor. The door provides a large, flat surface and when not in use I just lean it up against a wall. In addition, the door protects my projects from getting scratched and

nicked by the concrete floor.

Many lumberyards and home centers offer slightly damaged solid-core doors in their scratch and dent department. (I purchased a door locally for \$10.)

*Zack Stilwell*

*Hudson, Wisconsin*

**Editor's Note:** A Hollow-core door may cost less and be lighter, but it's not as sturdy and won't stand up well under heavy loads.

■ Waterstones need to be saturated in water to work properly. But between use, the stones dry out. So to speed up the time it takes to saturate a waterstone, I store my wet waterstones after each use in plastic "Zip-Lock" bags.

Since the water can't evaporate, it only takes a few seconds to ready a stone for the next use.

*Jon deFlon  
Liberty, Missouri*

## Auxiliary Fence Tip

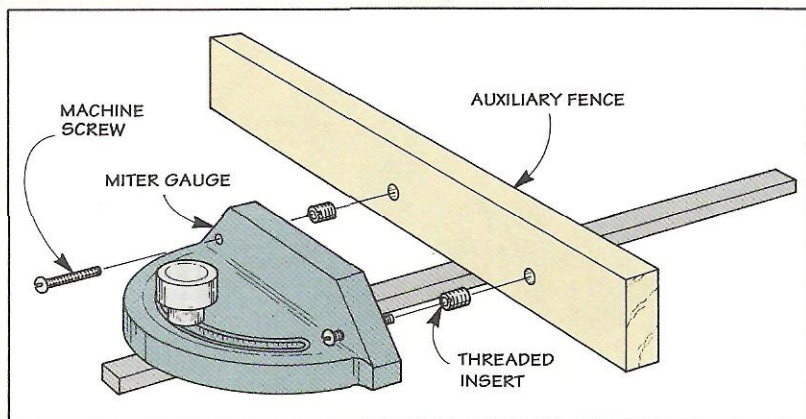

■ For extra support, I often temporarily screw an auxiliary fence to my miter gauge, see Drawing. The only problem with this is the woodscrews eventually strip out the holes in the auxiliary fence.

To solve this problem, I re-

placed the woodscrews with machine screws and threaded inserts, see Drawing. (Note: This also makes installation and removal quick and easy.)

*Christian Sharps  
Big Timber, Montana*

## Keyless Chucks

I just finished reading about keyless chucks in *ShopNotes* No. 7. In the article you mentioned they're not intended for use on a drill press.

But in a catalog I recently received from Grizzly Imports, I noticed they offer a keyless chuck just for a drill press. What gives?

*John Matthews*

*Cave Creek, Arizona*

**Editor's Note:** We weren't aware of this chuck until we received John's letter. So we ordered one from Grizzly. (We spent \$38 for the chuck and \$5 for an arbor the chuck required. For a source, see page 31.)

*We've been using the new chuck for about a month. The chuck seems to be very well made and is quick and easy to use.*

## Drill Bit Spacer

■ Locating a hole or a slot an exact distance away from the edge of a workpiece can be tricky. The problem is measuring between a round drill bit and a flat fence.

To avoid this, I use a drill bit as a spacer, see Drawing. Just select a spacer that's the same diameter as the distance you're positioning the fence. Then place the spacer between the fence and the bit, and clamp the fence in place.

*Dennis Delvin  
New Brighton, Minnesota*

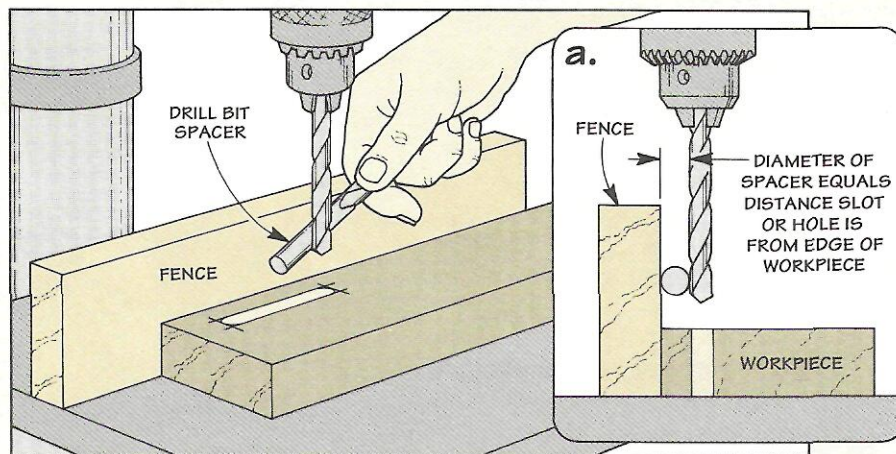

## Saw Guard

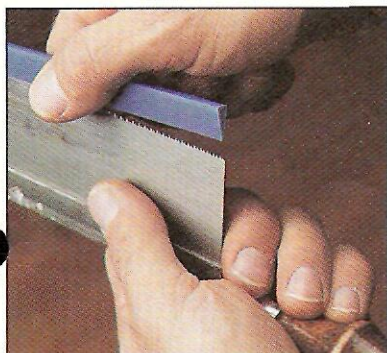

■ To protect the teeth on my hand saws, I use plastic binders from report covers, see photo. (You can purchase these for under \$1 from most office supply stores.)

Just remove the binder (the part that pinches the report between the plastic sheath), and slide it over the teeth of the blade.

*Larry Freund  
Port Washington, New York*

## Send in Your Solutions

If you'd like to share original solutions to problems you've faced, send them to: *ShopNotes*, Attn: Shop Solutions, 2200 Grand Ave., Des Moines, IA 50312.

We'll pay up to \$200 depending on the published length. Send an explanation along with a photo or sketch. Include a daytime phone number so we can call you if we have questions.

# Abrasive Pads



One of the secrets to getting a smooth finish on a project is to “sand” in between coats. This eliminates any “nibs” that can be caused by anything from dust in the air to bubbles in the finish.

For years I used sandpaper or steel wool in between coats to smooth out the finish. But recently I came across a new product and decided to give it a try—abrasive pads. I was impressed.

The pads didn't clog up with dried finish like sandpaper or leave tiny “slivers” behind like steel wool. And they were flexible enough to mold to the curved parts of the project.

To find out more about how the pads work, I gave Mike Virgintino from the 3M Company a call.

**WEB.** He said that the pads consist of small abrasive particles that are bonded into a “web” of interlocking fibers. This web is

what gives the pad the flexibility to conform to irregular shapes.

**RESISTS CLOGGING.** The web design also prevents the pads from loading up with dried finish. As you rub the pad across the workpiece, the fibers wear away and expose fresh abrasive parti-

---

*Abrasive pads don't clog up like sandpaper or leave tiny “slivers” behind like steel wool.*

---

cles. So it's like having a new pad with each stroke. The result is a *uniform* surface that accepts the next coat of finish evenly.

**WATER-BASED FINISHES.** One other advantage of the pads is they're especially suitable to the new water-based finishes. That's because the fibers that make up the web are *synthetic*. So unlike steel wool, you don't run the risk

of accidentally leaving behind a “sliver” that can rust when the finish is applied.

**SOURCES.** Although they look suspiciously like a kitchen scouring pad, abrasive pads aren't found in the grocery store. The pads I bought were hanging next to the sandpaper at the hardware store. They're also available in several tool catalogs, see Mail Order Sources on page 31.

**BRANDS.** Regardless of where you buy abrasive pads, you're likely to see a variety of brand names like Scotch-Brite, Bear-Tex or Scuff-Rite. That's because several different companies manufacture them including the 3M Company, Norton, and Gerson.

**COLOR-CODED.** In addition to the difference in brands, each manufacturer “color codes” the pads according to the grit, see photo at left. The problem is the coding isn't consistent from one company to the next. To ensure you're getting the grit you want, there's usually a steel wool equivalent in the product information.

**GRITS.** While the color of the pad may vary, one thing you *can* be sure of is the pads range in grits from very coarse to extra fine. The coarse grits can be used for heavy-duty stripping jobs. And the finer grits work well in between coats of finish or as a “polishing” pad.

For most finishing jobs, I scuff the dried finish with a #0 pad and then work up to a #00 pad before applying the next coat.



● Used for heavy stripping, a blue abrasive pad replaces #2 or #3 steel wool.

● A green (#0) pad scuffs up the surface of a dried finish to “anchor” the next coat.

● To produce a satin smooth finish, a gray (#00) pad removes the final irregularities.

● A white (extra-fine) abrasive pad is ideal for buffing out the final finish coat.

# Sources

*ShopNotes Project Supplies* is offering some of the hardware and supplies needed for the projects in this issue.

We've also put together a list of other mail order sources that have the same or similar hardware and supplies.

## BOX JOINT JIG

The shop-built Box Joint Jig (shown on page 6) attaches to your miter gauge and makes it easy to cut perfect-fitting box joints on the table saw. Note: The Box Joint Jig can also be used on the *ShopNotes* Router Table or any other router table that has a miter gauge slot.

But what sets this jig apart from other box joint jigs is how easily and accurately it can be adjusted. We used several pieces of hardware to create a unique micro-adjustable system that lets you "dial in" perfect-fitting box joints.

*ShopNotes Project Supplies* is offering a hardware kit that includes all the hardware needed to make the Box Joint Jig. We've even included the plastic star knobs and the metal plates to make the adjustable key. All you

need to supply is the hardwood and a small piece of 1/4"-thick Masonite.

**S6808-100** Box Joint Jig  
Hardware Kit ..... \$17.95

## BAND SAW FENCE

One sure way to improve the performance of your band saw is to add the Band Saw Fence System shown on page 16. This system consists of two basic parts: a set of metal rails, and a wood fence.

The special rail design allows you to adjust the fence to compensate for drift. (Drift is the tendency for a band saw blade to pull to one side when making a cut.)

The fence locks securely to the front rail and can be fitted with a couple of handy accessories. One is a tall auxiliary fence for added support when resawing. The other is an adjustable stop block.

*ShopNotes Project Supplies* is offering a hardware kit for the Band Saw Fence System. The kit includes all the hardware to build the fence (screws, bolts, nuts, washers, knobs, and a spacer).

We've also included the aluminum angle needed to make the rails. You'll receive three 24" long pieces (two pieces for the adjust-

able front rail, one piece for the back rail.) All you need to supply is the wood to make the fence, and the correct size mounting bolts for attaching the rails to the band saw table.

**S6808-200** Band Saw Fence  
Hardware Kit ..... \$24.95

## SLIDING BEVEL GAUGE

All you need to make the Sliding Bevel Gauge featured on page 22 is a small amount of wood and a few brass parts.

The brass screws and nuts can usually be found at a local hardware store. The 1" x 12" brass strip and the brass rod are available at most hobby stores.

However if you can't find these parts locally, *ShopNotes Project Supplies* is offering a kit that includes all the brass parts (not the wood) to make the Bevel Gauge.

**S6808-300** Sliding Bevel  
Gauge Hardware Kit ..... \$4.95

## KEYLESS CHUCK UPDATE

In Shop Solutions (on page 29) we mentioned a keyless chuck (for a drill press) sold by Grizzly Imports. As far as we know, it's the only source for this type of chuck, see Mail Order Sources.

## MAIL ORDER SOURCES

*Similar hardware and supplies may be found in the following catalogs. Please call each company for a catalog or for ordering information.*

<b>Constantine's</b> 800-223-8087 <i>Auger Bit File, Hardware</i>	<b>Highland Hardware</b> 800-241-6748 <i>Auger Bit File, Diamond Needle Files</i>	<b>Woodcraft</b> 800-225-1153 <i>Abrasive Pads, Auger Bit File, Hardware</i>
<b>Garrett Wade</b> 800-221-2942 <i>Auger Bit File</i>	<b>Leichtung</b> 800-321-6840 <i>Abrasive Pads</i>	<b>The Woodsmith Store</b> 515-255-8979 <i>Abrasive Pads, Diamond Needle Files</i>
<b>Grizzly Imports</b> 800-541-5537 <i>Keyless Drill Press Chuck</i>	<b>The Sanding Catalogue</b> 800-228-0000 <i>Abrasive Pads</i>	<b>The Woodworkers' Store</b> 612-428-2199 <i>Hardware, Knobs</i>

## ORDER INFORMATION

### BY MAIL

To order by mail, use the order form that comes with the current issue. The order form includes information on handling and shipping charges, and sales tax.

If the mail order form is not available, please call the toll free number at the right for more information on specific charges and any applicable sales tax.

### BY PHONE

For fastest service use our Toll Free order line. Open Monday through Friday, 7:00 AM to 7:00 PM Central Time.

Before calling, have your VISA, MasterCard, or Discover Card ready.

**1-800-444-7527**

*Note: Prices subject to change after May 1, 1993.*



## Scenes From the Shop

*At the turn of the century, box joints (also called finger joints) were used extensively to mass produce boxes like the ones shown above. The strength of this joint comes*

*from the glue surface created by the close interlocking fingers. This allowed manufacturers to use thin wood to produce boxes that were both lightweight and sturdy.*