

TIPS • TOOLS • TECHNIQUES

ShopNotes®

Vol. 2

Issue 9



- Roll-Around Planer Stand
- Router Tune-Up Tips
- Tool Storage System
- Vertical Raised Panel Jig

EDITOR Donald B. Peschke
EXECUTIVE EDITOR Douglas L. Hicks
MANAGING EDITOR Terry J. Strohmman
ASSOCIATE EDITOR Richard S. Peters
ASSISTANT EDITOR Tim Robertson
CONTRIBUTING EDITOR Philip A. Totten

CREATIVE DIRECTOR Ted Kralicek
ART DIRECTOR Cary Christensen
SENIOR ILLUSTRATOR Kurt Schultz
ILLUSTRATORS Will Niskanen
 Roger Reiland
 Mark Higdon
PHOTOGRAPHER Crayola England

DESIGN DIRECTOR Ken Munkel
SENIOR DESIGNER Jan Hale Svec
DESIGNER Kent Welsh
SHOP MANAGER Steve Curtis

CIRCULATION

Circulation Director: Liz Bredeson • *Subscription Manager:* Phyllis Jessen • *Circulation Analyst:* Rod Cain • *Newsstand Sales:* Kent A. Buckton

PUBLISHING SERVICES

Associate Editor: Gordon C. Gaippe • *Sr. Graphic Designer:* Robert H. Whitmer

CORPORATE SERVICES

Controller: Paul E. Gray • *Accounting:* Laura Thomas • *Bookkeeping:* Julianne Spears • *Info. Services Manager:* Joyce Moore • *Electronic Pub. Coordinator:* Douglas M. Lidster • *Administrative Assts.:* Cheryl Scott, Julia Fish • *Receptionist:* Jeanne Johnson • *Bldg. Maint.:* Ken Griffith

PROJECT SUPPLIES

Marketing Director: Robert Murry • *Catalog Art Director:* Cindy Jackson • *Catalog Products Manager:* Bob Baker • *Project Supplies:* Linda Jones • *Technical Support:* Jeff Janes • *Systems Operator:* Linda Morrow • *Receptionist:* Keri Lee

CUSTOMER SERVICE

Customer Service Supervisor: Jennie Enos • *Customer Service Representatives:* Jennifer Murphy, Joy Johnson, Sara Kono, Ami Blanshan, Anna Cox, Chris Lo

SHIPPING DEPARTMENT

Supervisor: Jerry Carson • *Fulfillment:* Gloria Sheehan, Don McVey, Chuck Carlson, Sylvia Carey

ShopNotes (ISSN 1062-9696) is published bimonthly (Jan., March, May, July, Sept., Nov.) by Woodsmith Corporation, 2200 Grand Ave., Des Moines, IA 50312. ShopNotes is a trademark of Woodsmith Corporation. ©Copyright 1993 by Woodsmith Corporation. All rights reserved.
Subscriptions: Single Copy, \$4.95. One year subscription (6 issues), \$19.95. Two years (12 issues), \$35.95. Canada/Foreign, add \$4.00 per year.
Second Class Postage Paid at Des Moines, IA and at additional offices.
Postmaster: Send change of address to ShopNotes, Box 11204, Des Moines, IA 50340-1204
Subscription Questions? Call 1-800-333-5854, 8am to 5pm, Central Time, weekdays.

PRINTED IN U.S.A.

There's one thing you can be sure of. Sooner or later a woodworker will take a good idea and make it better. Take raised panel router bits for example.

I've always thought the *idea* of using a router bit to make raised panels on the router table made sense. But I never felt safe using large diameter (3"-4") bits at the high speed of most routers. (At 22,000 RPM's the speed at the rim of these bits is around 230 MPH.)

NEW BITS. Evidently, I wasn't the only one who disliked using these large router bits. Not long ago, a woodworker named Brad Witt designed and patented a new type of raised panel router bit. Instead of a large diameter *horizontal* cutter, the cutting edge is oriented *vertically*.

(Note: Brad Witt designs and sells a variety of router accessories through his *Woodhaven* catalog, see Mail Order Sources on page 31.)

These bits seemed like the perfect solution, so I ordered a couple to test out. When the bits arrived I was in the middle of some other project. So I set them aside until I had some free time. Before I knew it several months had gone by and I still hadn't found time to test the bits.

SHOP TEST. Finally I got my chance. Rick Peters (our Associate Editor) told me he wanted to make raised panel doors for his kitchen cabinets. So I offered to make his raised panels using one of the new vertical bits. Not being one to turn down free labor, Rick quickly agreed.

After routing dozens of raised panels (Rick has a large kitchen), I'm convinced that these bits are safer to use. But I did run into a couple of problems.

When using these bits the workpiece is held on *edge*. This can make it difficult to control, especially if it's a large piece. The other problem is the tip of the cut-

ting edge tears out the wood fibers.

Now it was our turn to improve on a good idea. To solve both problems, we designed a special jig that attaches to the top of the router table, see page 6.

Two of the other projects in this issue were also designed to solve problems that have come up in our shop.

PLANER STAND. When we bought our portable planer, I was impressed with its small size. This meant the planer could be stored out of the way when it wasn't being used. But lately, the planer seems to have gotten heavier and more awkward to move around (maybe I'm just getting older).

To make it easier to use (and save my back) we built a stand for it. The stand is made from one sheet of 3/4" plywood and can be easily wheeled around the shop. It even has an adjustable outfeed extension to support long workpieces.

TOOL STORAGE. There's no doubt that portable power tools make wood-working easier. And like many woodworkers, we've acquired a variety of power tools and accessories. The problem has always been storing them.

Putting the tools in cases keeps them organized, but they're not very accessible. Tools stored on a shelf are convenient to get to, but are hard to keep organized. (You've probably noticed that electric cords on power tools have a mind of their own and always tangle together like a plate of spaghetti.)

Our solution to this problem is the Tool Storage system shown on page 24. This system features the convenience of open-shelf storage *and* provides compartments to keep each tool organized.

TOOLWORKS. Also in this issue, we've added a new feature — Toolworks. The idea is to offer simple, straightforward information on keeping your wood-working tools in top condition. This time we take a look at how to tune up and maintain a router.

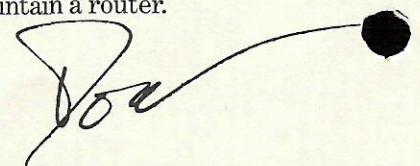

Contents

Jointer Push Block _____ 4

The unique design of this push block allows you to safely flatten the face of a board.

Vertical Raised Panel Jig _____ 6

All it takes to rout a professional-looking raised panel is this shop-made jig and a vertical raised panel bit.

Router Tune-Up _____ 10

A close look at router maintenance problems. And tips on keeping your router in top shape.

Edgebanding Plywood _____ 12

Three different types of veneer edging let you hide the exposed edges on a plywood project.

Portable Planer Stand _____ 16

An adjustable outfeed extension provides support for long boards. To make it easy to store, the extension "knocks down" and the stand tilts and rolls on a set of wheels.

Table Saw: Ripping _____ 22

Practical tips and shop-built accessories for ripping a workpiece safely and accurately on the table saw.

Tool Storage _____ 24

A place for everything, and everything in its place. That's the idea behind this easy-to-build storage system for your portable power tools.

Shop Solutions _____ 28

Five Shop-Tested Tips: Router Bit Depth Gauge, An Adjustment Block for your Router Table, Installing Threaded Inserts, Squaring-Up Large Panels, and a Cork-Bottom Sanding Block.

Lumber Grades _____ 30

You can save money on materials for a project by using the different grades of lumber to your advantage.

Sources _____ 31

Hardware, project supplies, and mail order sources for the projects in this issue.

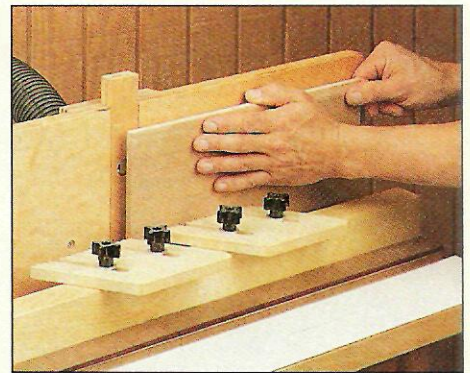

Raised Panel Jig page 6

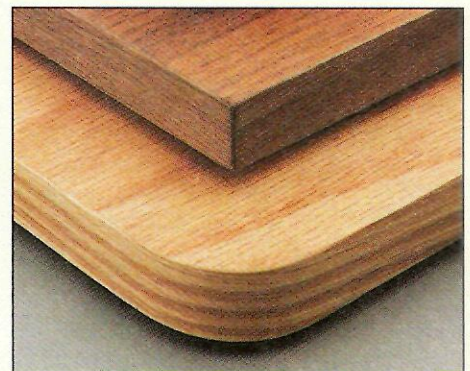

Edgebanding page 12

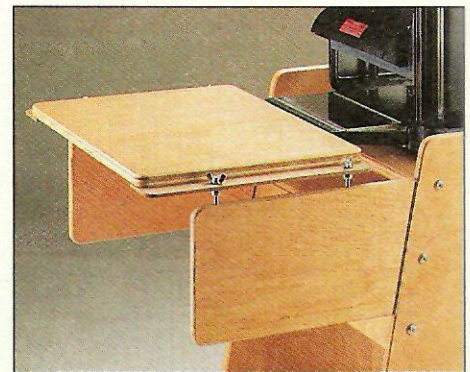

Planer Stand page 16

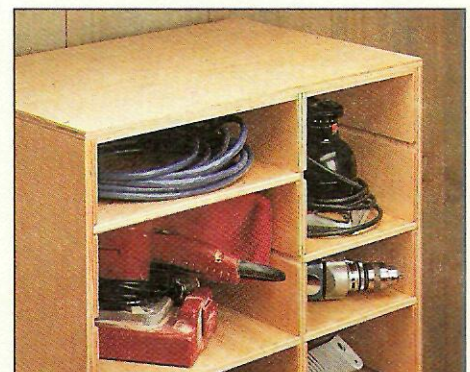

Tool Storage page 24

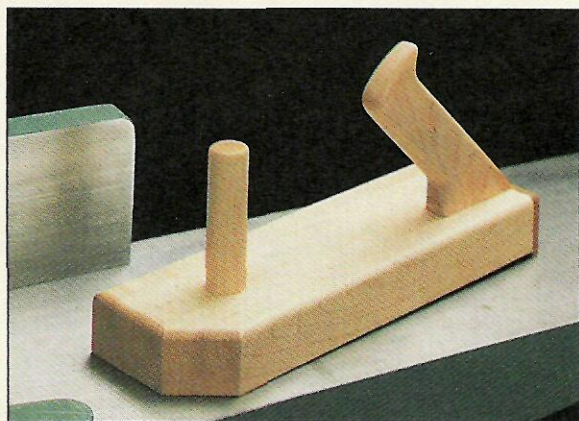

Jointer Push Block

This push block is designed to help you safely joint the face of a board.

A power jointer can do more than square up the edge of a board. It's also the perfect tool for flattening the *face* of a board. The problem is there's no safe place to put your hands and apply the pressure you need to push the workpiece over the cutterhead. To solve this problem, I made a special push block.

This push block lets you apply pressure in two directions. For-

ward to push the piece over the cutterhead. And *downward* to keep the board flat against the jointer table. (For more on using the push block, see the box on page 5.)

BODY. To distribute this pressure evenly, the *body* (A) of the push block is 12" long and 1½"-thick. But it's not made from a single piece of stock. Instead, it's glued up from five ¾"-thick strips, see Fig. 1. I did this for two reasons.

First, by building up the body in strips, it's less likely to warp or twist. Second, by cutting one of

the strips *shorter* than the rest, it's easy to create a "pocket" for the back handle that's added later, see Fig. 1.

POCKET. To provide some "knuckle room" between the handle and the jointer fence, the pocket is located *off-center*. To do this, start by gluing up three 12"-long strips and one 9¼"-long strip, see Fig. 1.

BACK HANDLE. After gluing up the four strips, the next step is to make the *back handle* (B), see Fig. 1. The shape of this handle is patterned after the handle on a bench plane so it

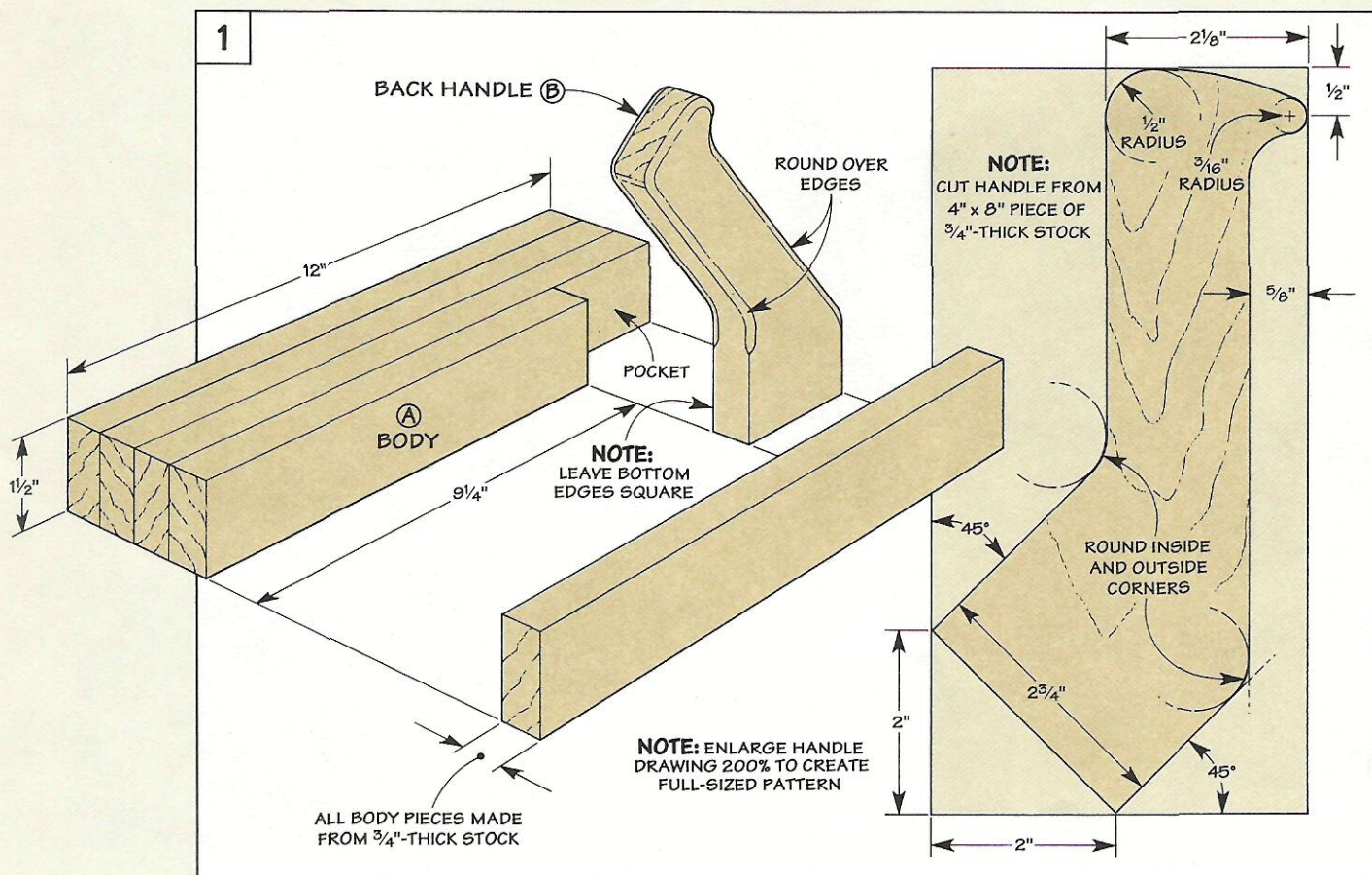

fits your hand comfortably.

LAY OUT SHAPE. To make the handle, start by laying out the shape on a piece of $\frac{3}{4}$ "-thick stock, see Fig. 1. (If you prefer, you can make a full-size pattern by enlarging the drawing 200% on a photo copier.)

Next, cut out the shape and round over the edges. Note: To ensure that the handle fits tightly in the pocket, don't round over the bottom edges.

ATTACH HANDLE. With the handle complete, the rest of the body can be assembled. This is just a matter of gluing the handle into the pocket. Then gluing the outside strip in place.

BEVEL CORNER. There's only one more thing to do to complete the body. To prevent the push block from catching the cutter guard when jointing narrow pieces, I cut a 45° bevel on the *front* outside corner of the body, see Fig. 2.

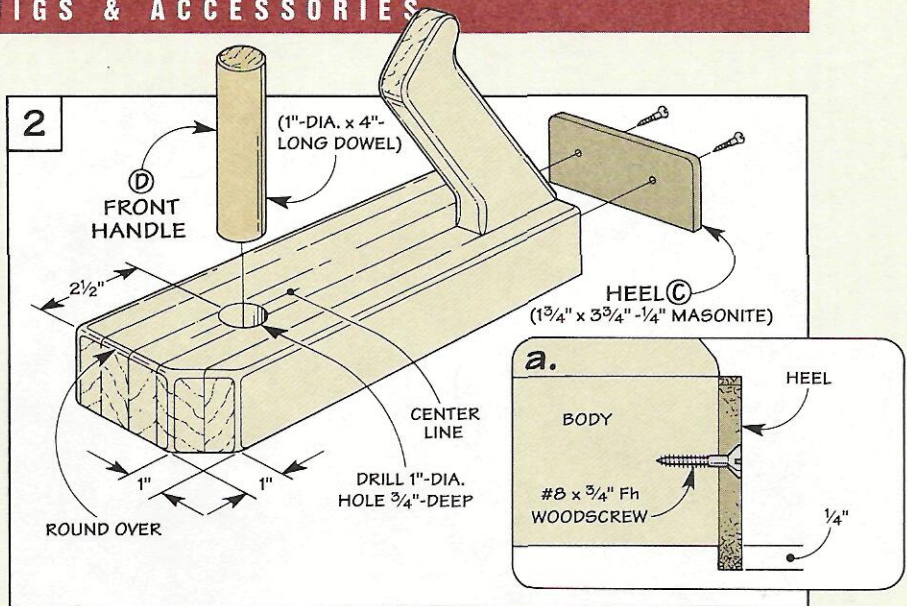

HEEL. After beveling the corner, the next step is to add the *heel* (C), see Fig. 2. The heel "hooks" over the end of a board which allows you to push it over the cutterhead. It's made from a piece of $\frac{1}{4}$ " Masonite that's glued and screwed so it extends $\frac{1}{4}$ " below the body, see Fig. 2a.

FRONT HANDLE. All that's left to complete the push block is to add the *front handle* (D), see Fig. 2. This handle provides a safe place for your left hand as you apply downward pressure on the workpiece. It's just a 1"-dia. hardwood dowel that's glued into a $\frac{3}{4}$ "-deep hole in the body.

Using a Push Block

The push block is designed with a couple of things in mind. First, it allows you to hold a board down flat on the jointer table throughout a cut. And second, it keeps your hands safely away from the cutterhead.

To do this, the heel of the push block is "hooked" over the end of the workpiece as you push forward with the back handle, see Fig. 1.

On a long board, the downward pressure is provided by placing your left hand on top of the workpiece in *back* of the cutterhead.

The idea here is to maintain consistent pressure as you feed the workpiece *underneath* your hand. When the push block is almost touching your left hand, transfer the pressure to the front handle and complete the cut, see Fig. 2.

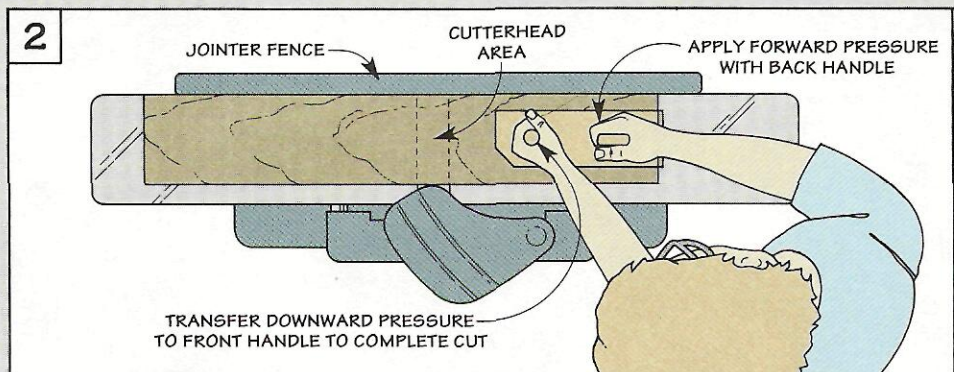
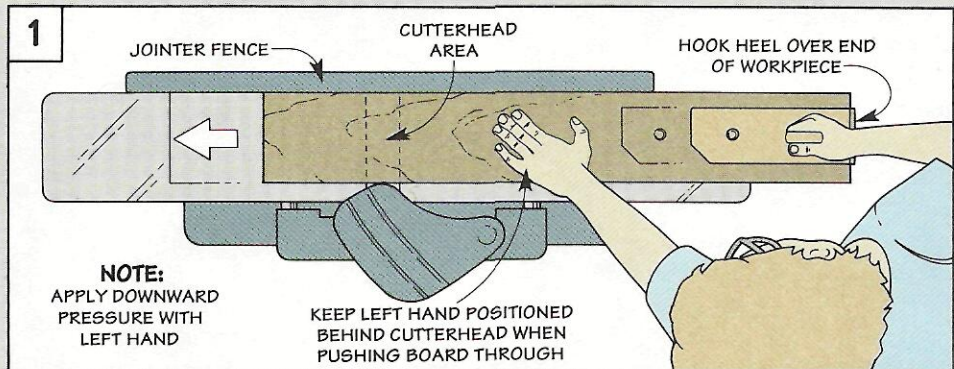

Vertical Raised Panel Jig

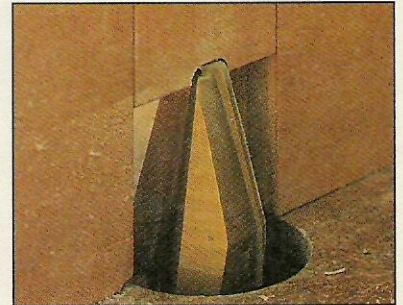
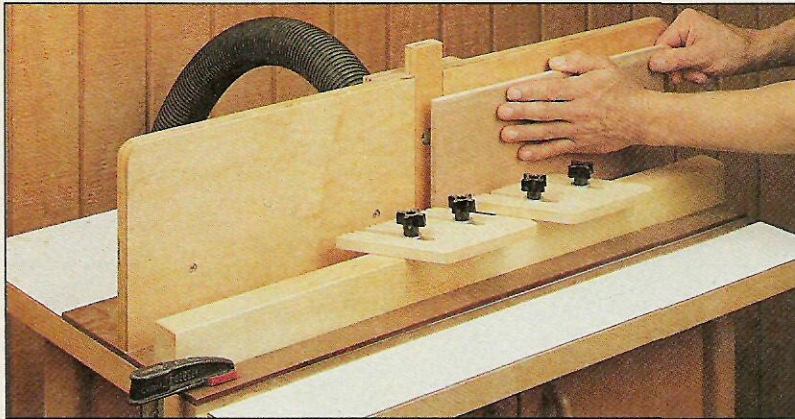

▲ To prevent chipout, a sliding insert forms a "zero-clearance" opening around the tip of the bit.

Every so often a product comes along that changes the way I approach a woodworking task. Take these vertical raised panel bits for instance. They're an excellent way to rout a decorative profile on a raised panel.

But the unique thing about these bits isn't *what* they do. It's *how* they do it. Instead of routing a profile with the panel held flat on the router table, the workpiece is held on its *edge*. That's because the cutting edges are oriented

vertically instead of horizontally like on most raised panel bits.

The advantage to all this is the bits are safer to use because not as much of the cutting edge is exposed. Instead of "sweeping" across a panel like the blades on a helicopter, the cutting edges on a vertical raised panel bit work more like a revolving door.

TALL FENCE. The main requirement when using these bits is a *tall* fence to support the workpiece. That's the basic idea

behind this vertical raised panel jig, see photo. In addition, we've added several other features that make it easy to rout professional-looking raised panels.

BASE. To provide a platform for the jig, I started work by making a *base* (A), see Fig. 1. The base clamps to your router table, so the length is sized to fit the top of the table (30" in my case).

Since the base sits on top of your router table, you'll need to make a hole for the bit to poke

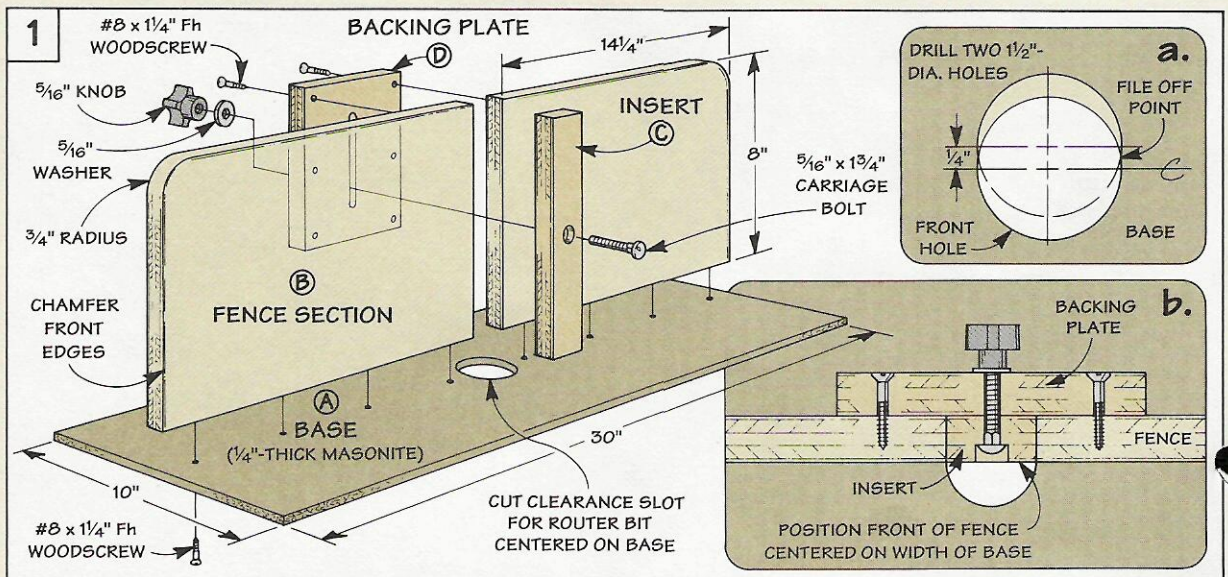

Hardware

- (26) #8 x 1/4" Fh Woodscrews
- (1) 5/16" x 1 3/4" Carriage Bolt
- (5) 5/16" Flat Washers
- (4) #8 x 3/4" Fh Woodscrews
- (4) 5/16" x 3" Hanger Bolts
- (5) 5/16" Knobs

through. By cutting a short "clearance" slot, the jig can be adjusted from side to side without the bit cutting into the base, see Fig. 1a.

FENCE

With the base complete, the next step is to add the fence. The fence is made up of three parts: two fence sections, an insert, and a backing plate, see Fig. 1.

FENCE SECTIONS. To prevent the fence sections (B) from twisting, I made them from 3/4"-thick pieces of plywood. And, to provide plenty of support for the workpiece, they're 8" tall (wide).

INSERT. With the fence sections cut to size, the next step is to add the insert (C), see Fig. 2. To adjust the opening above the bit, the insert slides up and down between the fence sections (B).

This way, the insert backs up the workpiece and prevents chipout at the tip of the bit. To lock the insert in position, a counterbored shank hole is drilled for a carriage bolt that's added later.

BACKING PLATE. To complete the fence, I added the backing plate (D), see Fig. 2. In addition

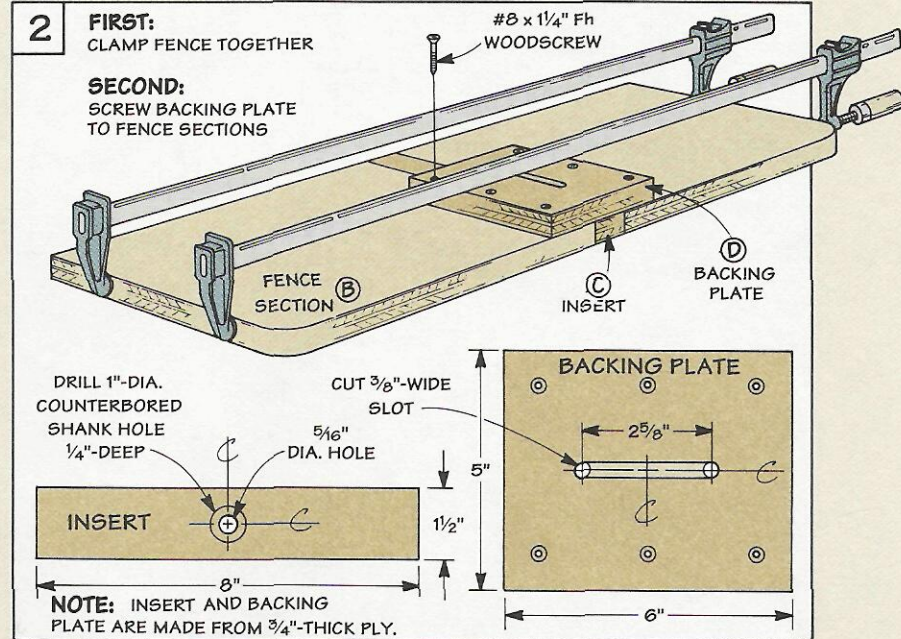

to holding the fence sections together, the plate has an adjustment slot that lets you raise (or lower) the insert.

Before attaching the plate, the important thing is to align the top and bottom edges of the fence sections. This ensures that the fence rests squarely on the base. To do this, clamp the insert between

the plate in place, see Fig. 2.

TRIM INSERT. Since the insert is pinched between the fence sections, you'll need to trim the edges so it slides easily. Then it's just a matter of installing a carriage bolt, washer, and knob, see Fig. 1.

ATTACH FENCE. Finally, the fence is screwed to the base so the front face is centered on the width of the base, see Fig. 1b.

Vertical Raised Panel Bits

Although vertical raised panel bits are only 1" in diameter, they still produce a 1 1/2"-wide decorative profile — the same as a horizontal raised panel bit with a diameter of 3 1/2". So what's the big deal about a smaller diameter bit that's shaped differently?

ROUTER SPEED. The biggest advantage is you can run them at full speed — about 22,000 rpm's for a "standard" single-speed router. (All that's required is a router with a 1/2" collet.)

That's too fast for a horizontal raised panel bit. Not only is it scary to have a huge hunk of metal whirling around that fast. It seems unsafe to me. To slow them down to a safe speed requires either a speed control or an

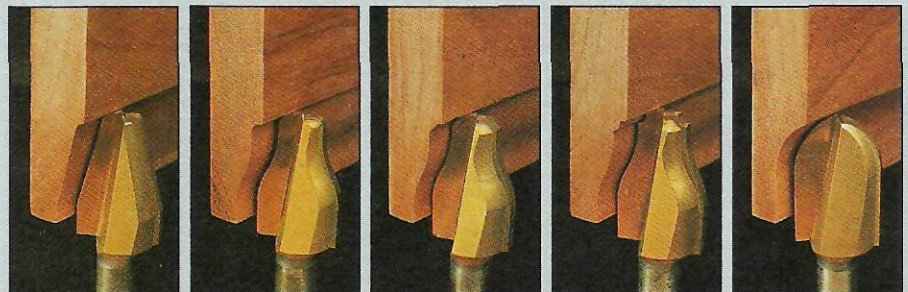

expensive variable speed router.

ROUTER TABLE. There's also another advantage to vertical raised panel bits. Because of the smaller diameter, you can use them without cutting a large hole in your router table.

PROFILES. In spite of the differences, the shapes of the profiles that

are available are basically the same, see photos above and Sources on page 31.

The bits here have a gold-colored protective coating that's designed to reduce heat build-up and prolong the life of the bit. However, this coating (and the color) may vary depending on where the bits are purchased.

Supports

After attaching the fence, the next step is to add the supports. The supports keep the fence at 90° to the base and provide a framework for the dust collection system.

SUPPORTS. The *supports (E)* are just four triangular-shaped pieces of plywood that are glued and screwed to the base and the back of the fence, see Fig. 3.

DUST HOOD. To collect the chips that are produced when routing a panel, I added a *dust hood (F)*, see Fig. 4. Note: You can also use the vacuum attachment for the router table featured in *ShopNotes* No. 1.

The dust hood is a piece of 1/4"-thick Masonite with a hole for the end of your shop-vac hose. Screwing the hood to the two middle supports forms a "chamber" that funnels the chips into the hose.

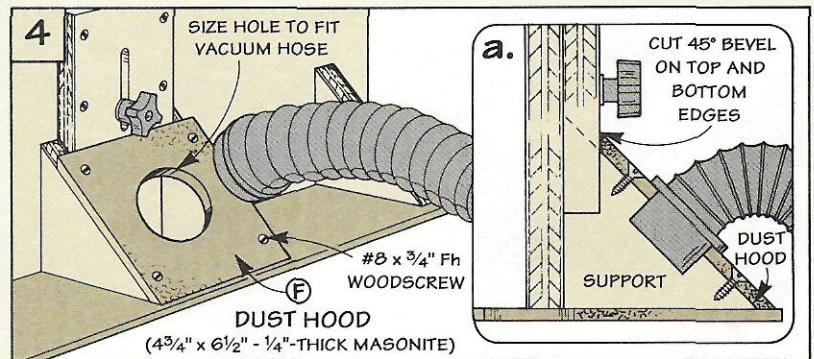
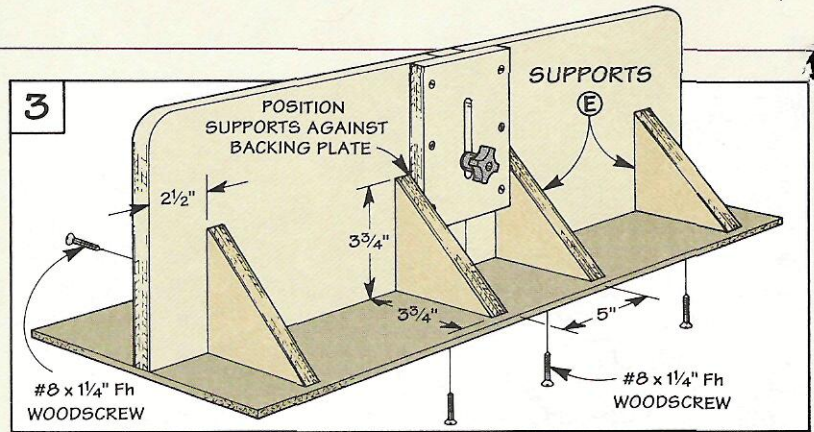

Featherboards

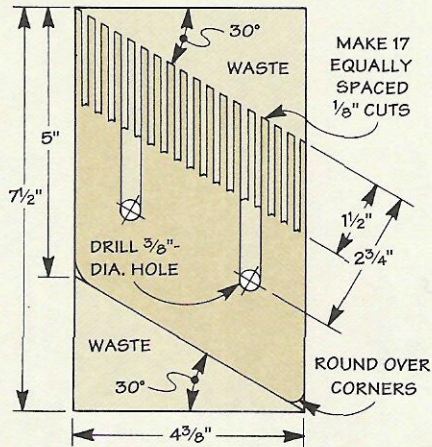

To produce a consistent profile, the workpiece needs to be held tightly against the fence. One way to apply this pressure is to add a pair of *featherboards (G)*, see Drawing above and Fig. 5.

Editor's Note: This is the same type of featherboard we used on the router table fence featured in *ShopNotes* No. 1. (A featherboard is also available from *ShopNotes Project Supplies*, see page 31.)

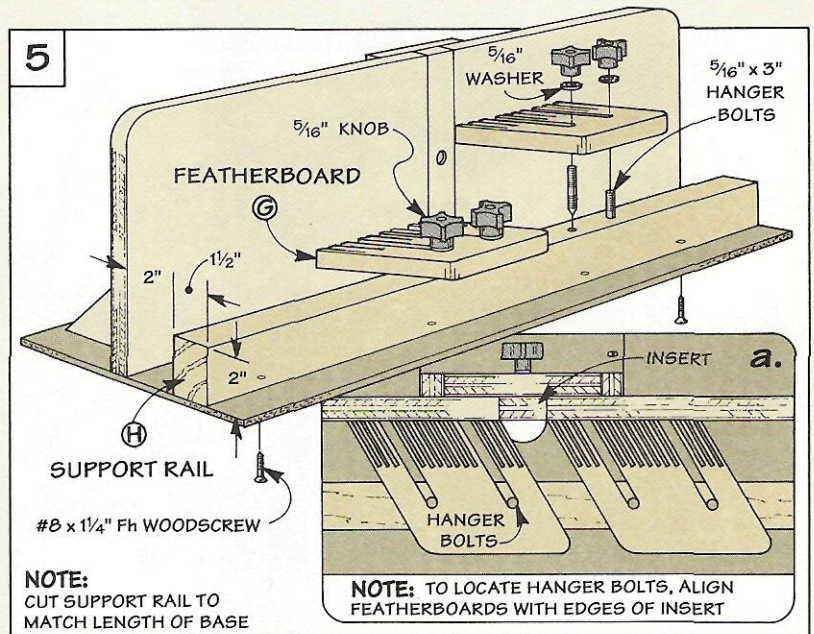

SUPPORT RAIL. To elevate the featherboards above the height of the bit, I added a 2"-tall (wide) *support rail (H)*, see Fig. 5. Why not just clamp them to the base? Because applying pressure that low on the workpiece tends to

"kick" the bottom into the bit and gouge the panel.

After gluing and screwing the rail to the base, it's just a matter of installing hanger bolts, washers, and knobs to tighten down the featherboards, see Fig. 5a.

Using the Jig

The secret to using this jig is to take a series of *light* passes. But unlike most router operations, this doesn't involve raising the bit between each pass.

Instead the bit is set to the full height (width) of the desired profile. Then the base of the jig is pivoted *slightly* between each

pass to gradually expose more of the bit, see Step 2 below.

NOTCH INSERT. Before making the final pass, a notch is routed in the bottom of the insert to create a "zero clearance" opening, see Step 3. This way, the insert backs up the workpiece and prevents chipout around the tip of the bit.



Step 1: Position Jig.

To set up the jig, position the base on top of the router table so the cutting edge of the bit extends $\frac{1}{8}$ " in front of the fence. The jig is held in place by tightening clamps on the infeed and outfeed sides of the base. Then, with the featherboards snug against the back of the workpiece, a right to left pass is made on each edge of the panel.

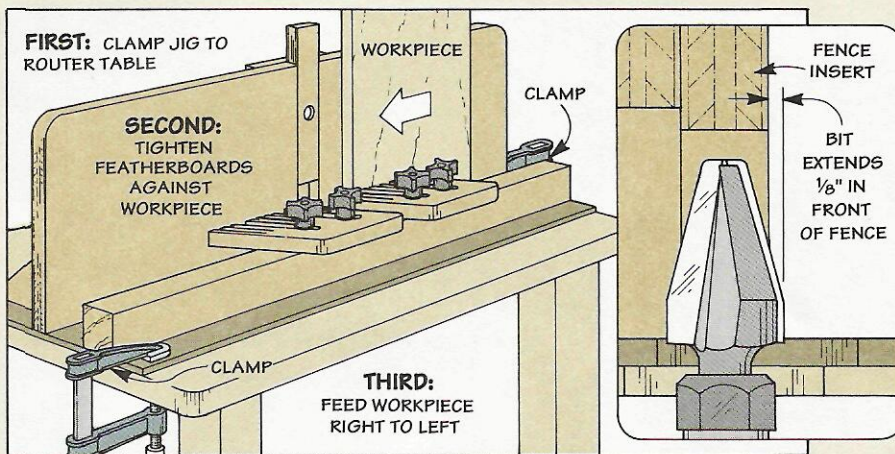

Step 2: Pivot the Base.

To increase the depth of the profile on each of the following passes, pivot the base of the jig to expose another $\frac{1}{8}$ " of the cutting edge. This is just a matter of loosening the clamp on the infeed side and sliding the base of the jig toward the back of the router table. Then retighten the clamp and make a pass on each edge from right to left as before.

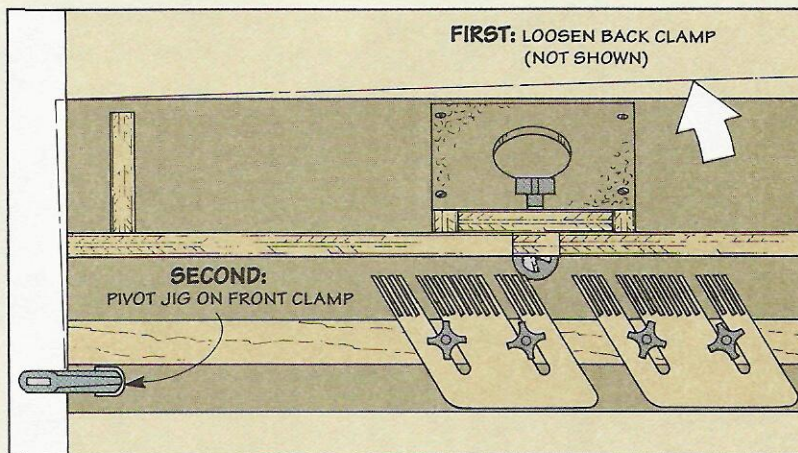

Step 3: Lower the Insert.

Before making the final pass, the insert is lowered onto the tip of the spinning bit to create a notch that's the same shape as the cutting edge. As a result of this "zero clearance" opening, the insert backs up the workpiece where chipout is most likely to be a problem — at the shoulder of the profile. When using a bit with a different profile, just make a new plywood insert.

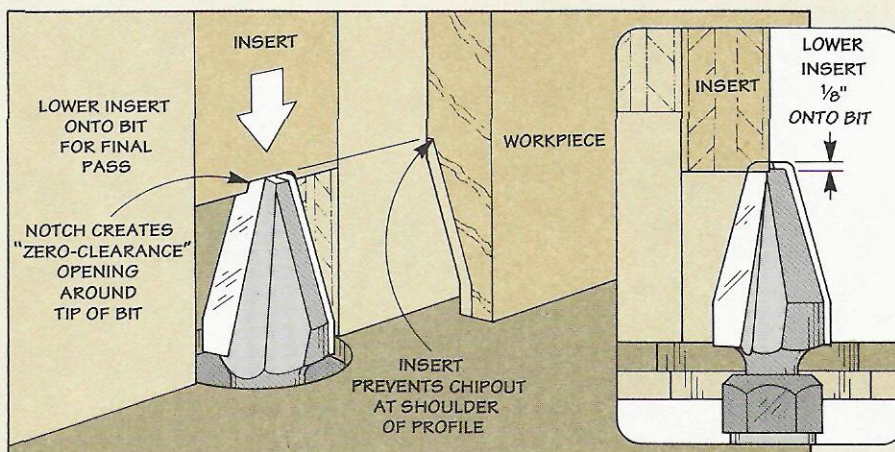

Router Tune-Up

All it takes is a few minutes to keep your router running smooth and trouble-free.



If it isn't broke, don't fix it. That's how I've always felt about my router. It's so dependable I take it for granted.

But recently, a bit slipped and ruined a nice piece of wood. The frustrating thing is this could have

been avoided if I'd just taken the time to tune up my router.

THE COLLET

The majority of router problems you'll encounter have to do with the bits. They "creep" out of the collet, or are difficult to install or remove. If you have these problems, start by checking the collet.

The collet is a tapered sleeve that fits in a tapered hole in the end of the router arbor, see Drawing at left. By tightening a nut on the end of the arbor, the collet squeezes the shank of the bit and holds it in place.

KEEP IT CLEAN. The problem is wood chips and sawdust find their way into the collet and prevent it from getting a good grip on the bit. The solution is simple. Keep the end of the arbor and the collet clean.

To do this, remove the collet from the arbor and clean out the end of the arbor with a round bristle brush, see Fig. 1. Then I use the brush to clean out both the inside and outside of the collet, see Fig. 1a.

Note: To prevent the brush from scratching the arbor and

collet, use either a brass gun-cleaning brush or a nylon brush (the kind used to clean percolator-style coffee pots).

Finally, wipe all the parts clean with a soft rag and reassemble. Note: Don't apply any lubricants — it may cause the bit to slip.

CLEAN BITS. To keep the collet clean and smooth, it's a good idea to also clean the *shanks* of your router bits. I use steel wool to remove any rust, resin, or small burrs that have accumulated.

WORN OUT. If cleaning doesn't solve the problem, the collet may be worn out and should be replaced. (Replacement collets are available at many tool centers.)

THE BODY

Another common problem with routers is the two main parts of the body (the motor housing and the base) often catch or bind as the height of the bit is adjusted.

CLEAN PARTS. Here again the solution is to keep these parts clean. Separate the motor unit from the base and clean both units, see Fig. 2. Pay particular attention to the height adjustment mechanism, see photos on the bottom of page 11.

LUBRICATE PARTS. To keep the body parts sliding smoothly, I follow up the cleaning with a light coat of *dry* lubricant. (Petroleum

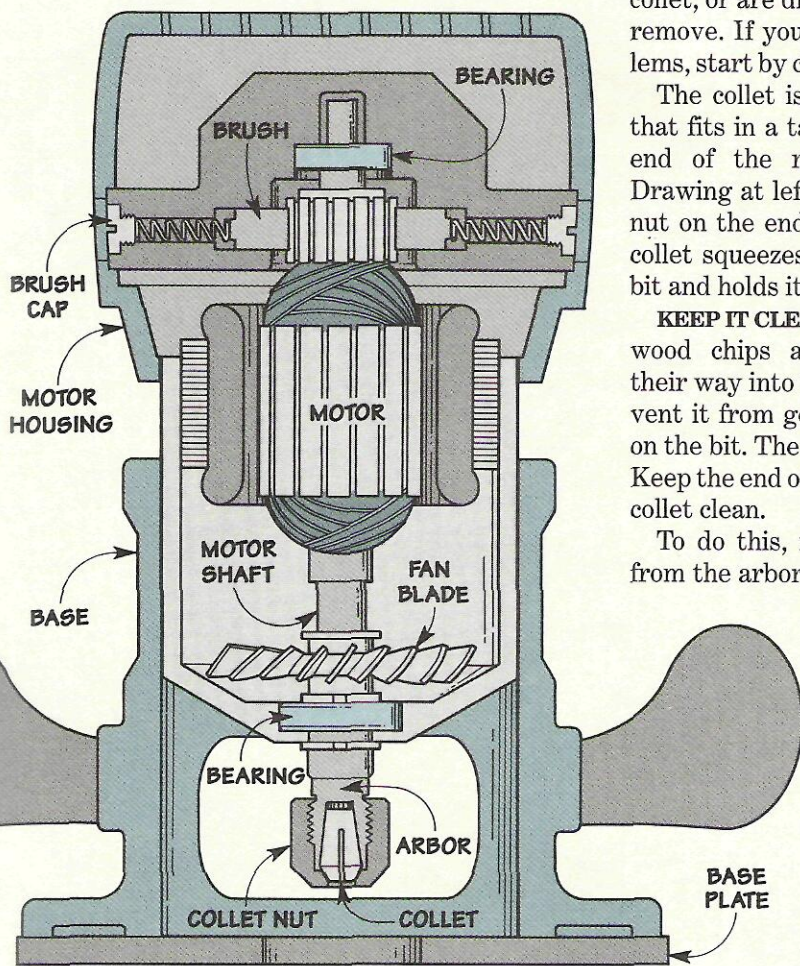

based lubricants attract dust and will gum up parts.) Most hardware stores carry a variety of dry lubricants such as silicon, Teflon, graphite or wax.

Of these four types, I prefer a silicon spray. It dries quickly and leaves behind a thin layer of lubricant that won't attract dust.

BASE PLATE. One part of the body that's often overlooked is the base plate, see Fig. 2. Scratches and grooves in the plate create ridges and burrs that can cause the router to "drag" as it slides over a workpiece.

To keep the router sliding smoothly, I sand the base plate lightly with 220 grit sandpaper to remove any burrs or ridges. Then follow this with a coat of paste wax.

BRUSHES & BEARINGS

In addition to the collet and the body, there are two other parts of your router that may need some attention. If your router has seen a lot of service, you may need to check your brushes and bearings, see Drawing on page 10.

Although these parts don't require any routine cleaning or lubrication (most router bearings are sealed), they eventually wear out and need to be replaced. So how can you tell when they're on their way out? Look and listen.

LOOK. If you notice excessive sparking near the top of the mo-

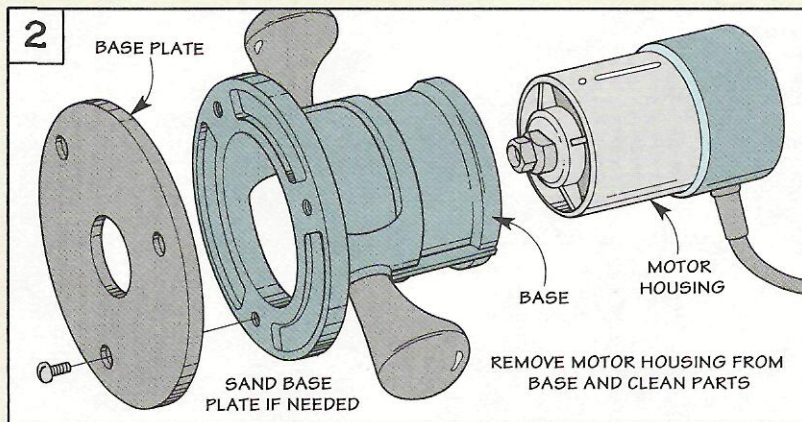
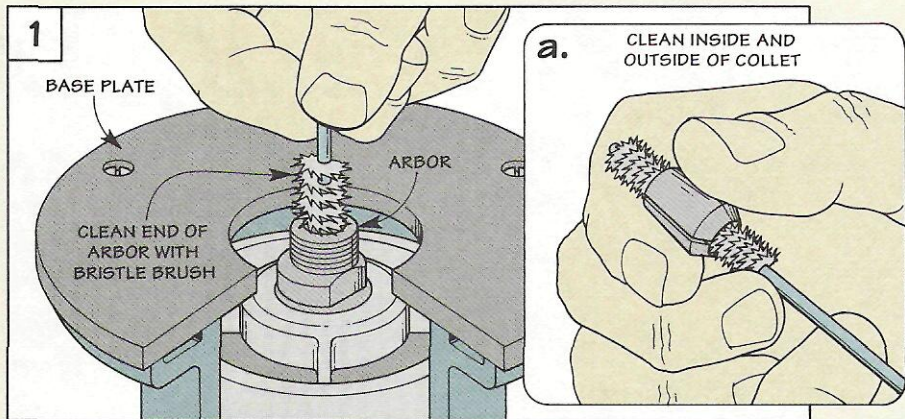

tor unit (where the brushes are located), your brushes may need to be replaced. Replacement brushes can be found at most tool service centers, motor repair shops, and some hardware stores.

LISTEN. One of the most obvious symptoms of bearings going bad is the howling or grinding noise they emit. If you notice this noise, take your router to a tool

outlet or service center and have your bearings checked and replaced if necessary.

A FINAL THOUGHT. Remember, the short time it takes to periodically tune up your router can prevent many of these problems from occurring. The time spent will pay off with a router that runs well and won't break down when you need it the most.

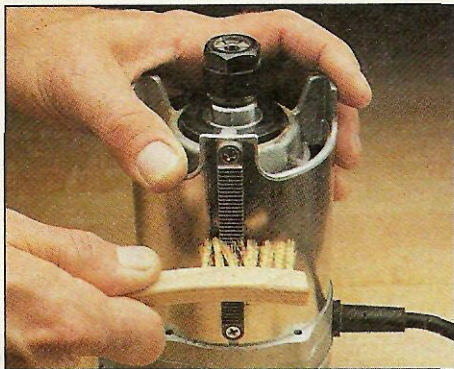

Rack and Pinion: I like to use a brass brush or an old toothbrush to clean the "teeth" on this type of height adjuster.

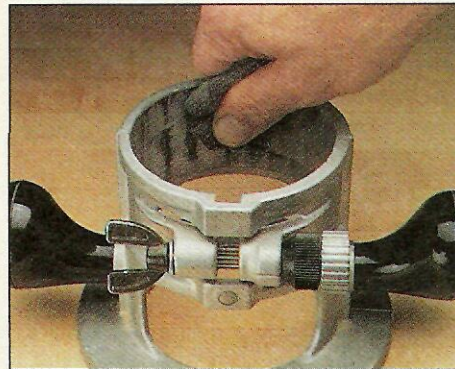

Pin and Groove: Steel wool works well to remove burrs and scratches that can form on the motor housing and base.

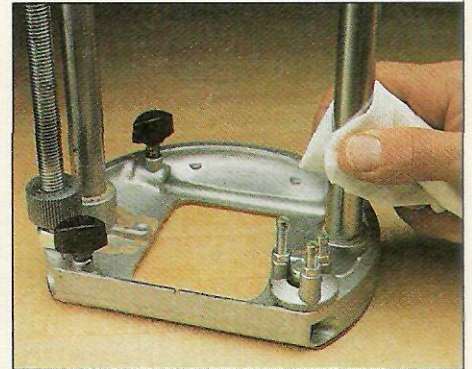

Plunge Tubes: Use a soft rag to clean the plunge tubes and rods. Then follow up the cleaning with a dry lubricant.

Edgebanding Plywood

A few simple techniques and some thin strips of veneer edging are all you need to hide a plywood edge.

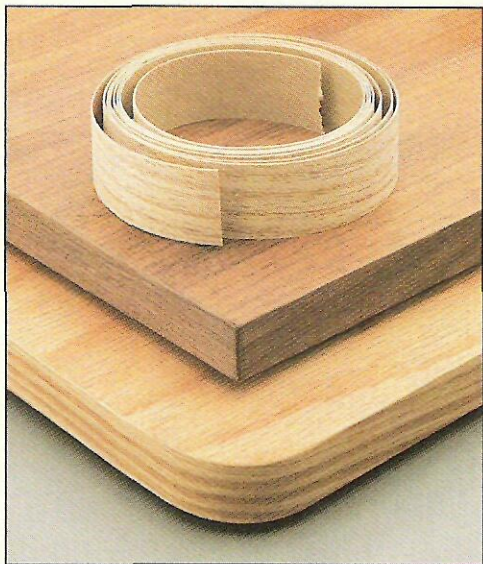

One of the quickest and easiest ways to hide the edges of a plywood project is to apply a strip of veneer edging or edgebanding. This is a thin “ribbon” of wood that’s about the same thickness as a heavy piece of paper.

To match the plywood of the project you’re working on, veneer edging is available in most of the common hardwoods like oak, walnut, and cherry.

And to ensure there’s enough material to cover the thickness of the edge, it comes in rolls that vary in width from $\frac{3}{4}$ " to 2". (For sources of veneer edging, see page 31. There’s also information on making your own on page 13.)

TYPES OF EDGING

Basically, all veneer edging is made from thin strips of solid

wood. The only difference is how the edging is applied.

GLUE-ON EDGING. The most traditional (and least expensive) is a plain wood strip without any adhesive on the back. The trick is to apply these strips without using a lot of clamps. One sure way to create an “instant” bond is to use contact cement, see photo A.

But this can also be a problem if the edging touches the plywood *before* it’s aligned. To keep from accidentally gluing the edging down in the wrong place, I use a “slipsheet.”

SLIPSHEET. This is just an ordinary piece of paper that you lay across the edge *after* the contact cement skins over, see Fig. 1. The slipsheet keeps the glued surfaces from sticking together so you can position the edging.

To do this, I use two fingers to center the edging on the thickness of the plywood, see Fig. 1. Once the strip is in position, it’s just a matter of sliding the slipsheet out a little at a time and pressing the veneer in place.

IRON-ON VENEER. Another kind of edging comes with a layer of adhesive already on the back. This edging is applied by melting the glue with an iron, see photo B. Although you can buy special irons to do this, an old household iron set on high works just as well.

The thing to be aware of with iron-on edging is that the glue doesn’t set up immediately. While it’s in this “gooey” state, the veneer can slide out of alignment as you work your way around the edge. To prevent this, I iron one end of the strip first. Then, after

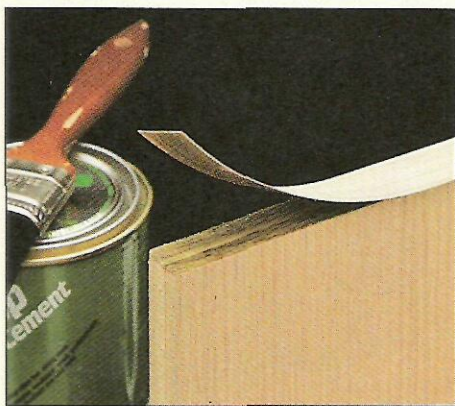

A. Glue-On Edging. Contact cement creates an “instant” bond between glue-on veneer edging and the plywood.

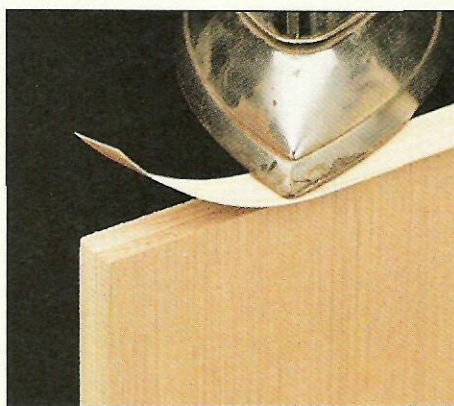

B. Iron-On Veneer. To glue this edging to the plywood, melt the layer of adhesive on the back with an ordinary iron.

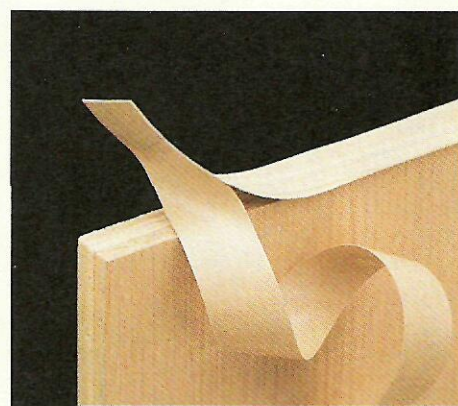

C. Veneer Tape. This is the easiest of the edgings to apply. Just peel off the backing and press the strip into place.

letting the adhesive cool, the edging can be pulled tight and “tacked” at several points.

Now it’s just a matter of ironing the rest of the edging. The idea is to keep the iron moving so it doesn’t scorch the veneer, but leave it long enough to melt the glue. Usually, a few seconds is all it takes to create a good bond.

SELF-ADHESIVE TAPE. One last kind of edging is self-adhesive veneer tape. This tape has a protective backing that peels off to expose the adhesive, see photo C.

Although it costs a little more than the other edgings, it’s by far the easiest to apply. Just strip off the backing, position the edging as before, and press it into place.

EDGE-BANDING TIPS

Regardless of the type of veneer edging you use, there are a few simple tips that can keep problems from cropping up.

PREPARE EDGE. One of the most important things is to start with a clean, flat edge. That’s because any stray wood fibers that get left behind end up looking like a “lump under the rug” when the edging is applied.

To clean up the edge, I use a low-angle block plane. Then I follow up with a sanding block and a piece of fine grit sandpaper. A light touch is all it takes

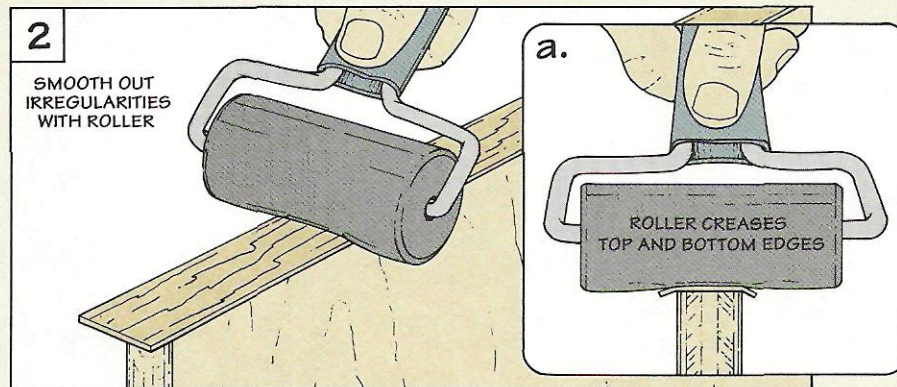
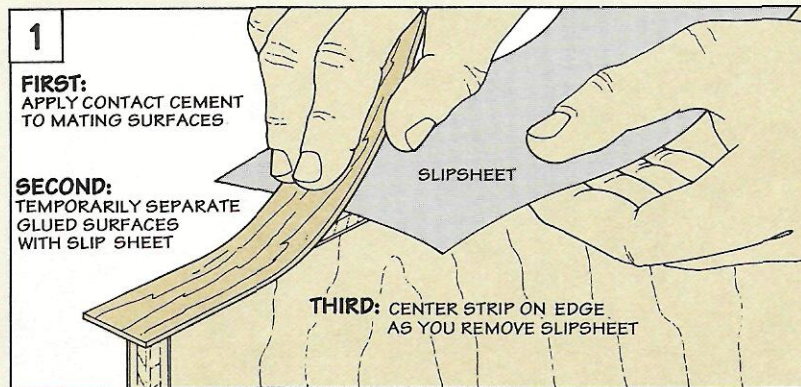

here. The idea is to keep from rounding over the edge which will create a gap between the plywood and the edging.

LENGTH. After preparing the edge, the edgebanding can be cut to rough length. To ensure that the edging is long enough to cover both ends, I cut pieces about 1" longer than I need and let the ends hang over. Then they can be trimmed off flush later.

ROLLER. Another thing you can do to get a good bond between the edging and the plywood is to roll the edging after it’s applied, see Fig. 2.

I prefer a rubber roller because there’s a certain amount of “give” in the rubber that creases the wood fibers at the top and bottom edges, see Fig. 2a. These creases serve as a guide when trimming off the edges.

Making Veneer Edging

Ideally, the edging matches the color and grain of the plywood. But that’s not always the case with store-bought edging. One source that’s guaranteed to match is the veneer from the scrap pieces of plywood you’re working with.

RESAW VENEER. To remove this veneer, you’ll need to resaw the top layer off a scrap piece of plywood, see Drawing. The idea is to cut as thin a strip as

possible. But even so, some of the backing from the ply underneath will still remain.

This backing can give the strip just enough “thickness” to show up as a thin layer between the veneer and the plywood. Also, it tends to curl the veneer if the strip isn’t applied immediately.

REMOVE BACKING. To prevent this, all you need to do is scrape (or sand) off the backing.

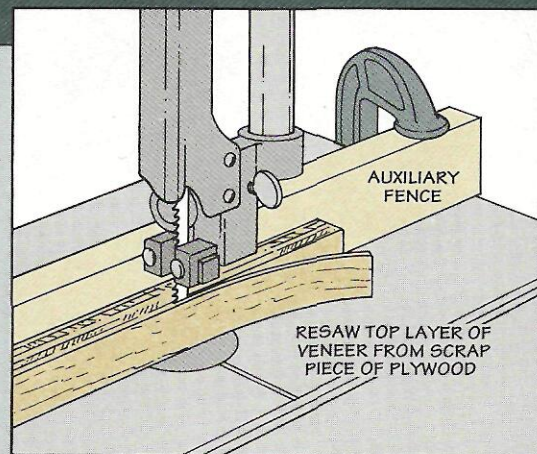

Trimming the Ends

After applying each piece of edgebanding, the next step is to trim the ends flush with the corners of the plywood.

The important thing here is to support the edging so the overhanging ends don't chip or break off. To do this, you can either stand the piece on edge, see Fig. 3. Or if the piece is too awkward to handle easily, back up the cut with a block of wood.

UTILITY KNIFE. To make as clean a cut as possible, I use a utility knife with a *sharp* blade. The idea is to slide the flat part of the blade against the edge of the plywood that's adjacent to the veneered edge, see Fig. 3. This way, the edge forms a "cutting guide" that allows you to trim the ends perfectly flush with the corner.

SPLICE. Trimming the end flush on a corner is relatively simple. But what happens when you need to "splice" two ends together in the *middle* of an edge? For example, when a long edge requires more than one strip. Or a single strip wraps around an edge with rounded corners.

OVERLAP ENDS. To get the ends to butt tight together, I use

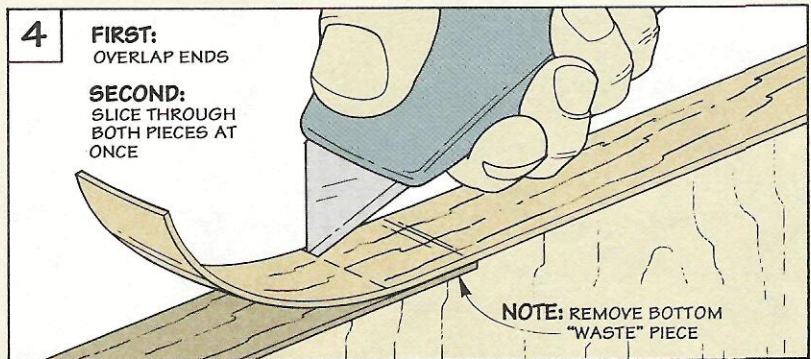
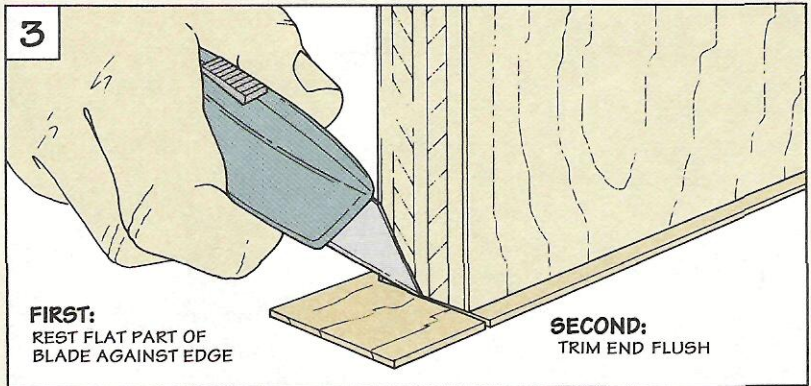

a simple technique.

The idea here is to overlap the ends slightly and slice through *both* pieces at once, see Fig. 4. Since the blade cuts along the exact same line on each piece, the two ends fit together perfectly when you remove the short

"waste" pieces.

The only thing to watch out for is that you don't glue the *bottom* end down when you're applying the edging. Instead, leave a couple of inches "free" at the end. Then glue it down *after* trimming the ends.

Plastic T-Molding

A variation on typical wood veneer edgebanding is T-molding, see photo. Like veneer, it's also used to cover the edge of plywood. But this edging is made of durable plastic.

T-molding is held in place by pressing the *tongue* into a narrow groove that's centered on the edge of the plywood. Note: You'll need a $\frac{1}{16}$ " slot cutter bit to rout the groove, see Drawing.

To prevent the T-molding from loosening up, the tongue has several small ridges that work like the barbs on a fish hook.

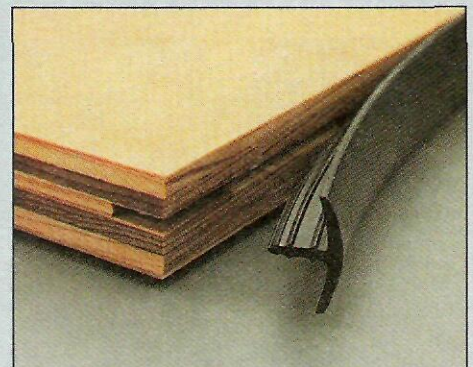
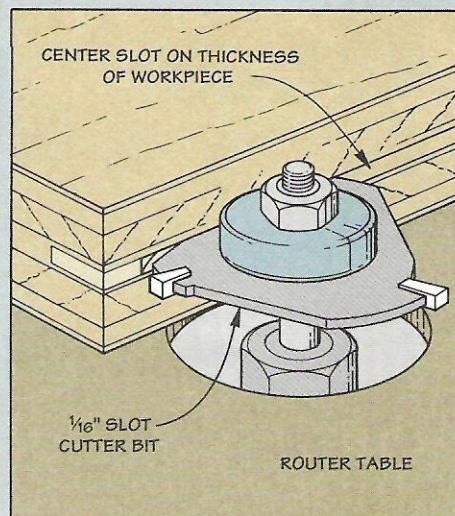

Plastic T-Molding is a durable edge treatment for plywood. To hold it in place, the tongue fits into a narrow groove that's centered on the edge.

Trimming the Edges

With the ends flush at the corners of the plywood, all that's left to do is trim the "extra" off the top and bottom of the edging. Here again, I use a utility knife with a sharp blade. (There are also several different edge-trimming tools available, see box below.)

To create a crisp edge, the trick is to trim the edging as close as possible to the surface of the plywood without actually cutting into it. As with the ends, the plywood provides a convenient cutting guide.

CUTTING GUIDE. The only difference is that this time the flat part of the blade rides against the *surface* of the plywood, see Fig. 5. With the blade in this position, it's simply a matter of drawing the knife along the edge to produce a smooth, even cut.

GRAIN DIRECTION. One thing to be aware of when trimming the edge is the grain direction of the edging. That's because the blade has a tendency to "follow" the grain, especially on coarse-grained woods, see Fig. 6.

To prevent this, I use a slightly different approach at places where the grain "rises" toward

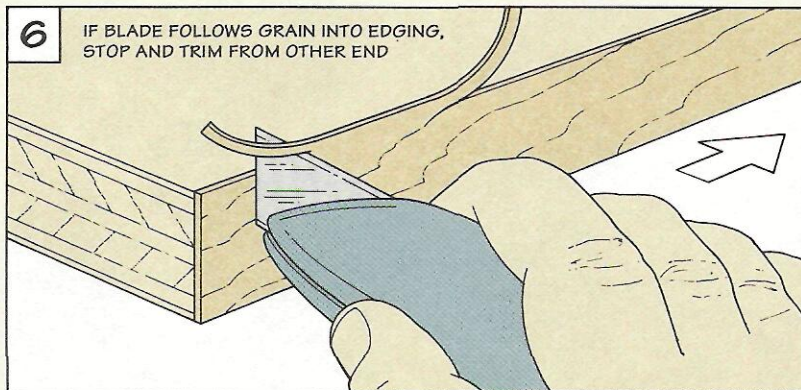
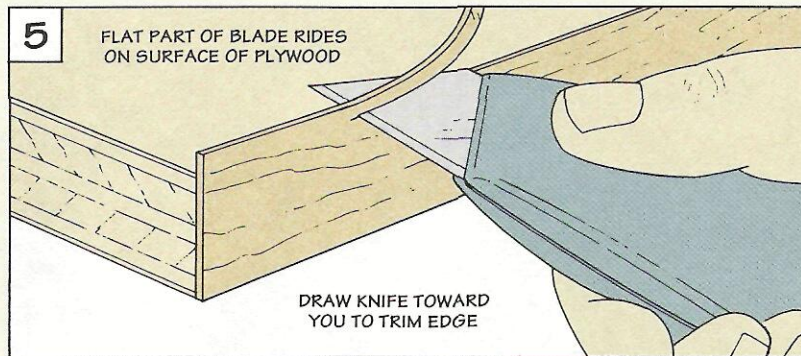

the cutting edge of the blade. The idea is to work from both ends *toward* the problem area, see Fig. 6. This keeps the blade from veering off into the edging.

BEVEL EDGE. Once the edges are trimmed flush with the surface of the plywood, there's only

one more thing to do.

To keep the edging from accidentally being snagged, I bevel the edge slightly by taking a few light passes with a sanding block. This also cleans up any glue that has squeezed out along the edge.

Edge Trimmers

Edgebanding doesn't require a lot of special tools. But when you have a lot of edging to do, an edge-trimmer is handy to have around.

Basically, there are two kinds available. One trims a single edge at a time. And the other removes both edges simultaneously, see photos. (For sources of these trimmers, see page 31.)

As an option, you can buy a separate blade for the single-edge trimmer that also bevels the edge. The double-edge trimmer has a second "built-in" blade that automatically cuts the bevel.

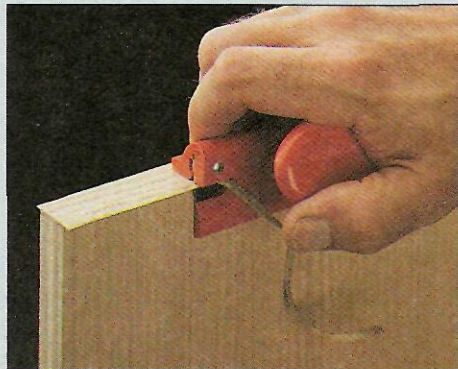

Single-Edge Trimmer. As a fence rides against the edge, the blade on this trimmer cuts the overhanging edge flush with the surface of the plywood.

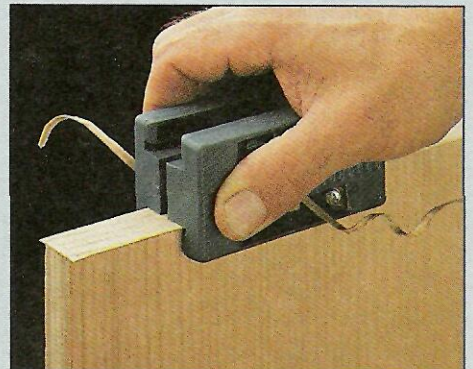

Double-Edge Trimmer. Spring-loaded sides on this trimmer adjust to the thickness of the plywood. Blades on each side remove both edges simultaneously.



Portable Planer Stand

This roll-around stand features an adjustable outfeed extension along with an optional storage drawer.

Put a handle on it and call it portable. That seems to be the idea with “portable” planers. But weighing in at 58 pounds, my portable planer is a chore to lift and carry around. So I decided to make it *truly* portable by building a roll-around stand for it, see photo above.

ACCESSIBLE & MOBILE. There are a number of advantages to mounting a planer to a stand. First, it’s always accessible. I don’t have to drag the planer out and look for a place to clamp it down. Instead, it’s always set up and ready to use.

Second, adding a pair of wheels to the stand allows you to roll it around wherever you need it.

For instance, when planing long boards, you might move it over near an open door — or even outside onto the driveway.

OUTFEED EXTENSION. To make it even easier to plane long boards, I added an outfeed extension, see photo above. The extension provides additional support to your workpiece as it comes out of the planer.

KNOCK-DOWN. And when it’s not being used, the outfeed extension “knocks down.” The table lifts off, and the two support “wings” fold flat against the sides, see photo below left.

DRAWER. Finally, the stand can be fitted with an optional drawer to hold all your planer accessories.

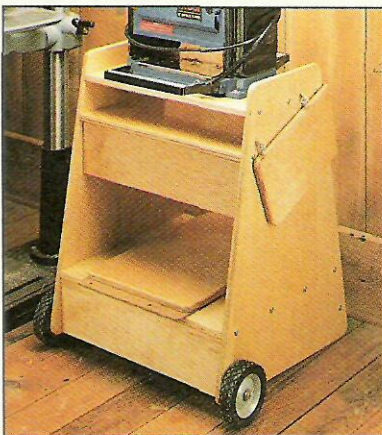

▲ The outfeed extension of the planer stand “knocks down” for moving and storage. The table lifts off and the “wings” fold back.

Cutting Diagram

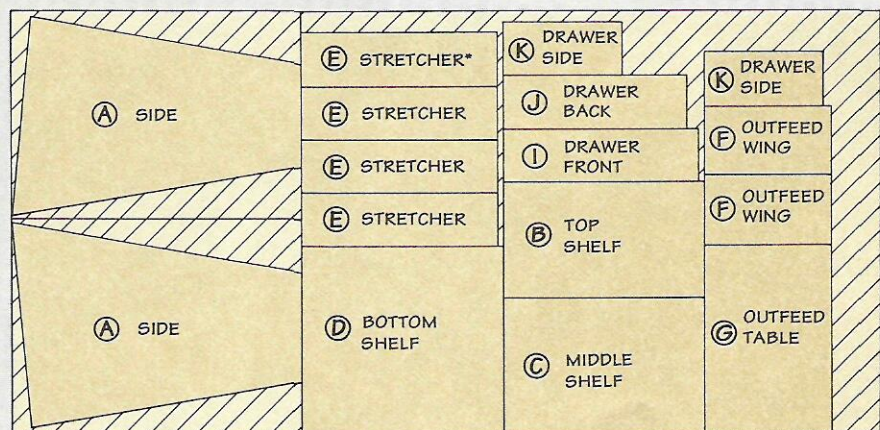

*NOT NEEDED IF DRAWER IS USED

48" x 96" - 3/4"-THICK PLYWOOD

EXPLODED VIEW

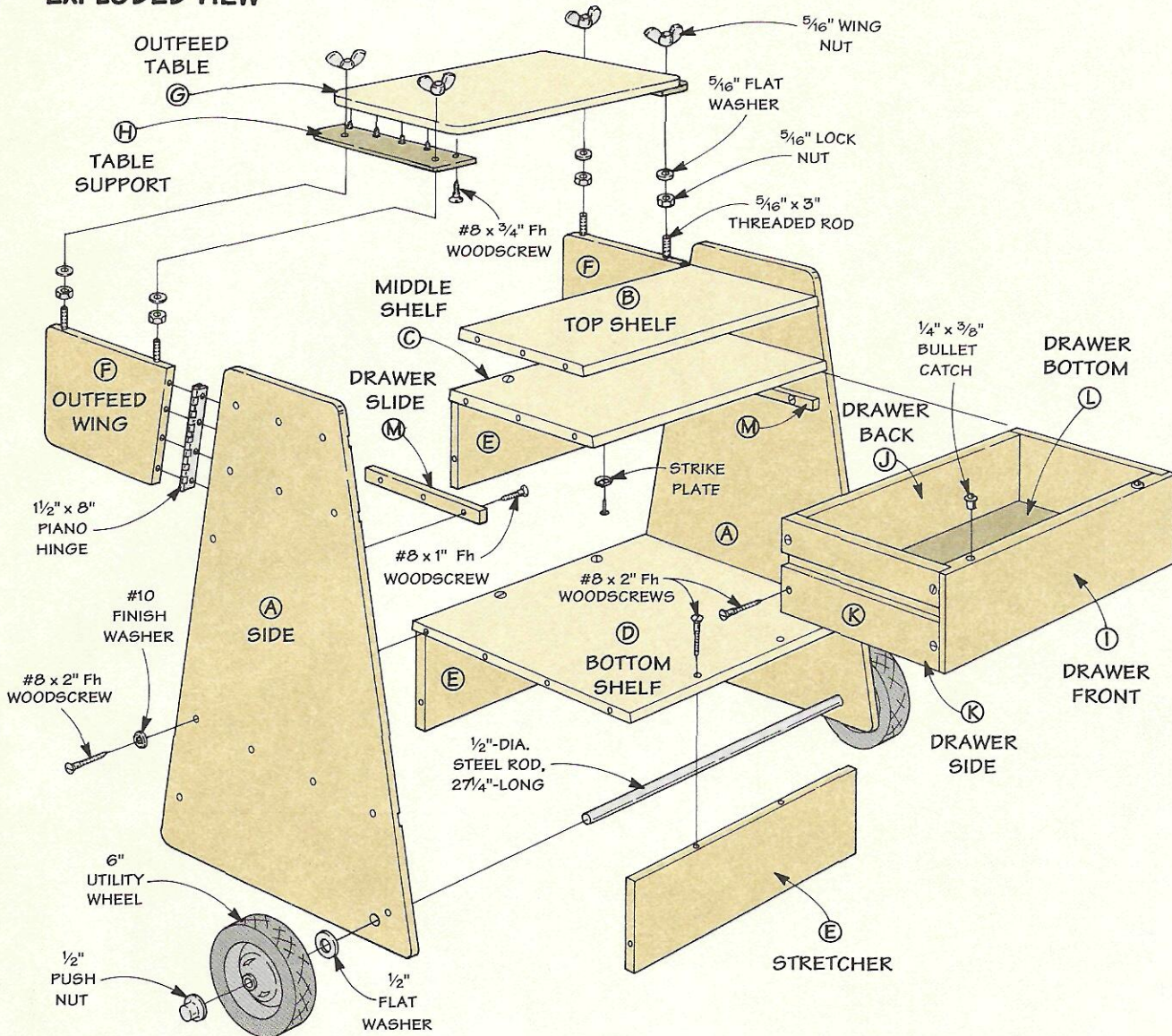

Materials

A Sides (2)	23 1/2 x 32 - 3/4 ply
B Top Shelf (1)	13 1/4 x 22 1/4 - 3/4 ply
C Middle Shelf (1)	15 1/4 x 22 1/4 - 3/4 ply
D Bottom Shelf (1)	21 1/4 x 22 1/4 - 3/4 ply
E Stretchers (4)	6 x 22 - 3/4 ply
F Outfeed Wings (2)	8 x 14 - 3/4 ply
G Outfeed Table (1)	21 1/4 x 14 - 3/4 ply
H Table Supports (2)	3 x 14 - 1/4 Masonite
I Drawer Front (1)	5 7/8 x 21 7/8 - 3/4 ply
J Drawer Back (1)	5 7/8 x 20 3/8 - 3/4 ply
K Drawer Sides (2)	5 7/8 x 13 1/4 - 3/4 ply
L Drawer Bottom (1)	12 1/2 x 20 7/8 - 1/4 Mas.
M Drawer Slides (2)	3/4 x 3/8 - 13

Supplies

- (44) #8 x 2" Fh Woodscrews
 - (28) #10 Finish Washers
 - (2) 1 1/2" x 8" Piano Hinges
 - (16) #5 x 1 1/4" Fh Woodscrews (for piano hinges)
 - (1) 1/2"-dia. Steel Rod 27 1/4" - long
 - (2) 6"-dia. Wheels*
 - (2) 1/2" Push Nuts
 - (2) 1/2" Flat Washers
 - (2) 1/4" x 3/8" Bullet Catches w/Strike Plates
 - (4) T-nuts and Bolts**
 - (6) #8 x 1" Fh Woodscrews
 - (4) 5/16" - 18 Threaded Rods, 3"-long
 - (4) 5/16" Lock Nuts
 - (4) 5/16" Flat Washers
 - (4) 5/16" - 18 Wing Nuts
 - (10) #8 x 3/4" Fh Woodscrews
- Also needed: 24" x 48" piece of 1/4"-thick Masonite
* Actual diameter is slightly less than 6"
** sized to fit your planer

The Case

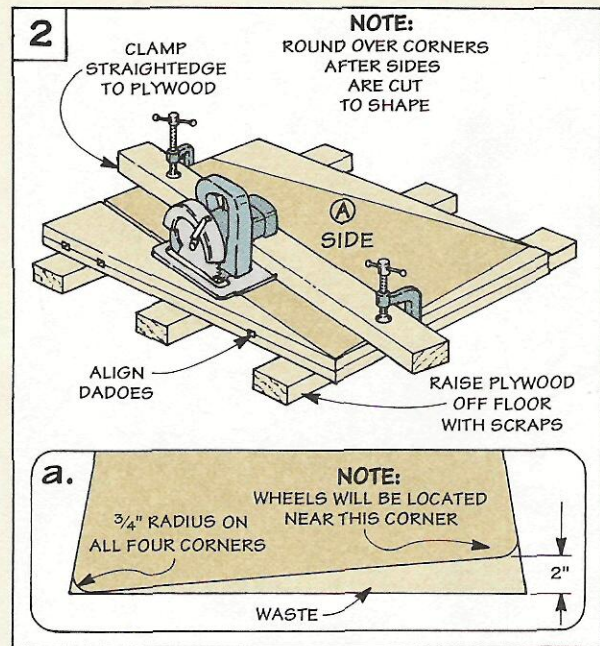
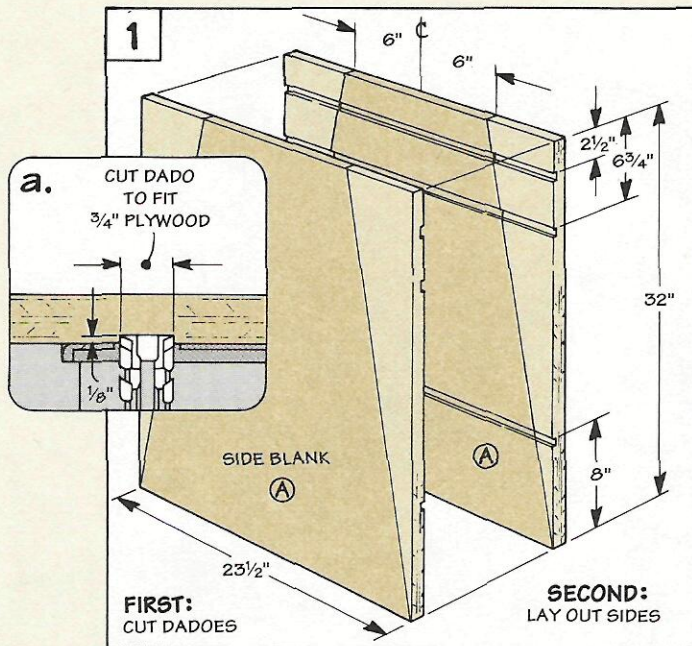

Finish washers prevent wood-screws from digging too deep into the plywood.

The planer stand is a simple plywood case: two sides dadoed to accept three shelves. I began work on the case by making the tapered sides, see Fig. 1.

SIDES

The sides (A) are shaped like flat-topped triangles — narrow at the top, and wide at the bottom for stability. Since it would be awkward

to cut dados in triangular-shaped pieces, I started with rectangular blanks, see Fig. 1 and the Cutting Diagram on page 16. Then I located and cut the shallow (1/8"-deep) dados for the three shelves.

ANGLED CUTS. Once the dados have been cut, the next step is to cut the sides to shape. The important thing here is to make sure

the pieces are the same shape and the dados align.

To do this, carpet tape the two blanks together with the dados aligned, see Fig. 2. Then lay out the angled cuts. Now, using a circular saw and a straightedge, cut the sides to shape.

Once the sides are tapered, use this same procedure to taper the bottom edge of the sides. (This provides clearance for the wheels that will be added later to the front of the stand.)

Finally, before separating the sides, I rounded over all four corners, see Fig. 2a.

SHELVES

With the sides complete, work can begin on the top (B), middle (C), and bottom (D) shelves, see Fig. 3. The top provides a solid platform for your planer. The middle shelf under the top is a handy place to set boards in between passes through the planer. And the bottom can be used for additional storage.

All three pieces are the same length (22 1/4"), the only difference is their width, see Fig. 3. The tricky part is getting each piece

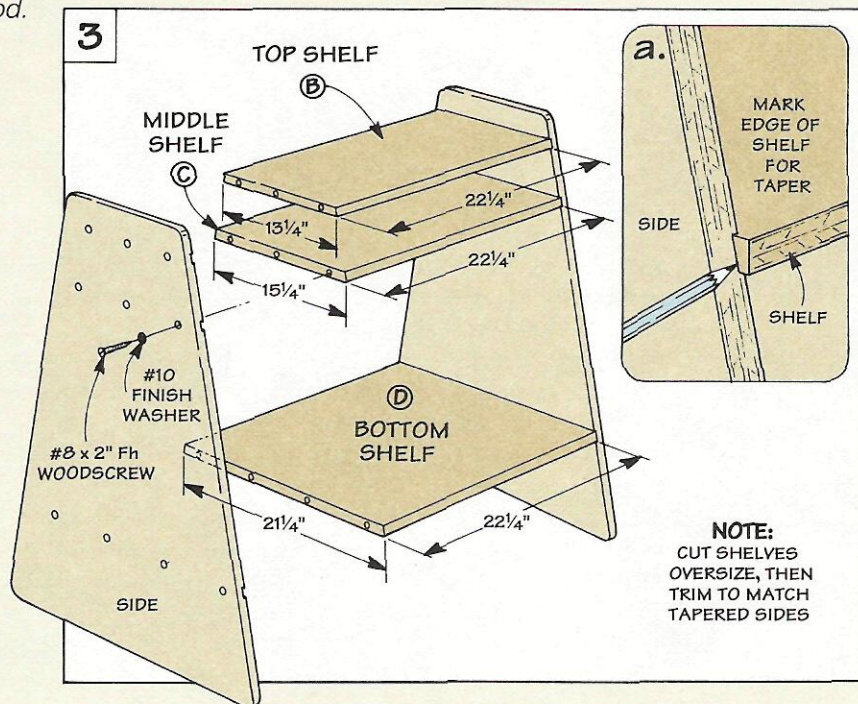

to the correct width so its edges match the taper of the sides.

BEVEL RIP. The easiest way to do this is to start by cutting the pieces slightly oversize. Then simply set each piece in its corresponding dado and mark the taper, see Fig. 3a. Now adjust the blade on your table saw to match this angle and rip each piece to final width.

ASSEMBLY. After the shelves have been cut, the stand can be glued and screwed together, see Fig. 3 and margin tip on page 18.

STRETCHERS

To strengthen the stand and prevent it from racking, I added stretchers (E), see Fig. 4. Note: If you're going to add the optional drawer shown on page 21, you'll only need three of these.

The *stretchers (E)* are all 6" tall (wide) and are cut to fit in between the sides. Then they're glued and screwed in place, see Figs. 4 and 4a.

WHEELS

To make the planer stand easy to move around, I added a pair of 6" rubber utility wheels, see Figs. 5

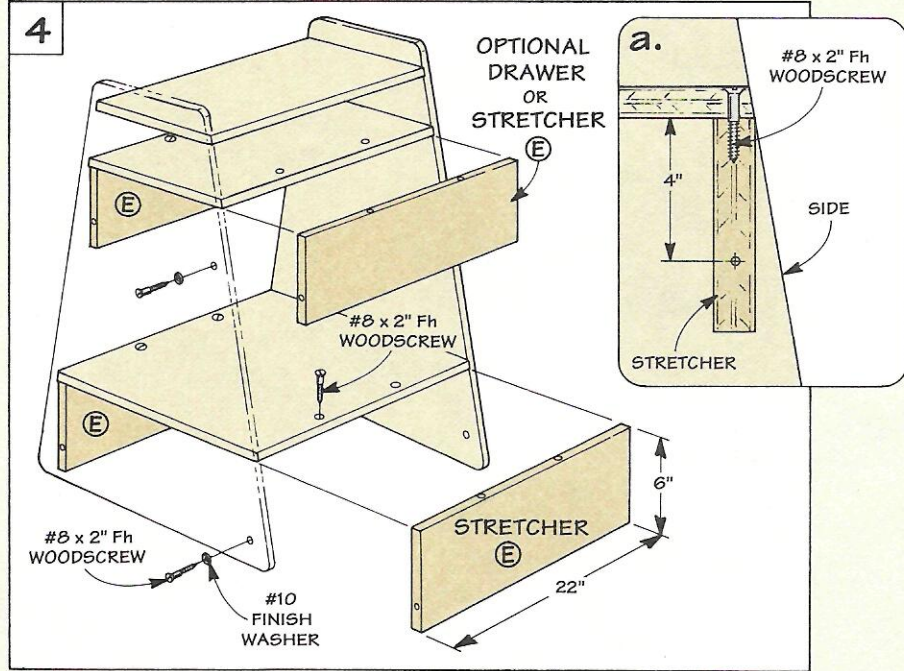

and 5a. (For sources, see page 31.)

The wheels slip onto a 1/2-dia. steel rod that passes through the sides. They're held in place with push nuts. (A push nut is a small metal "cap" that press fits onto a metal rod — no threads required.)

Note: To prevent the wheels from rubbing against the sides, I installed washers between the wheels and the sides, see Fig. 5b.

ATTACH PLANER. Now that the wheels are in place, the final step is to attach your planer to the stand, see Fig. 6. With the planer centered on the top shelf, mark and drill mounting holes. Then, I used T-nuts and bolts to secure the planer, see Fig. 6a.

To move the planer, just tilt the stand back (like a hand cart) and "wheel" it to where you need it.

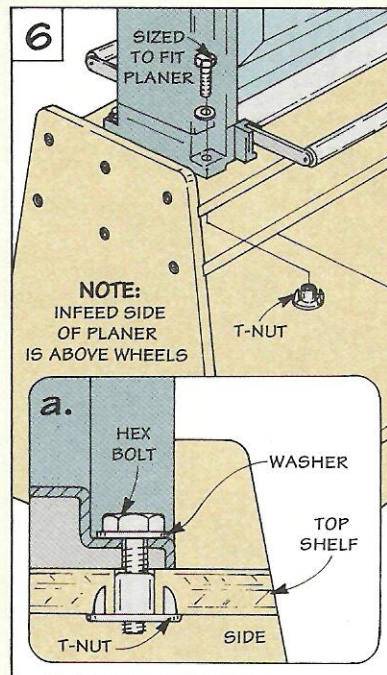
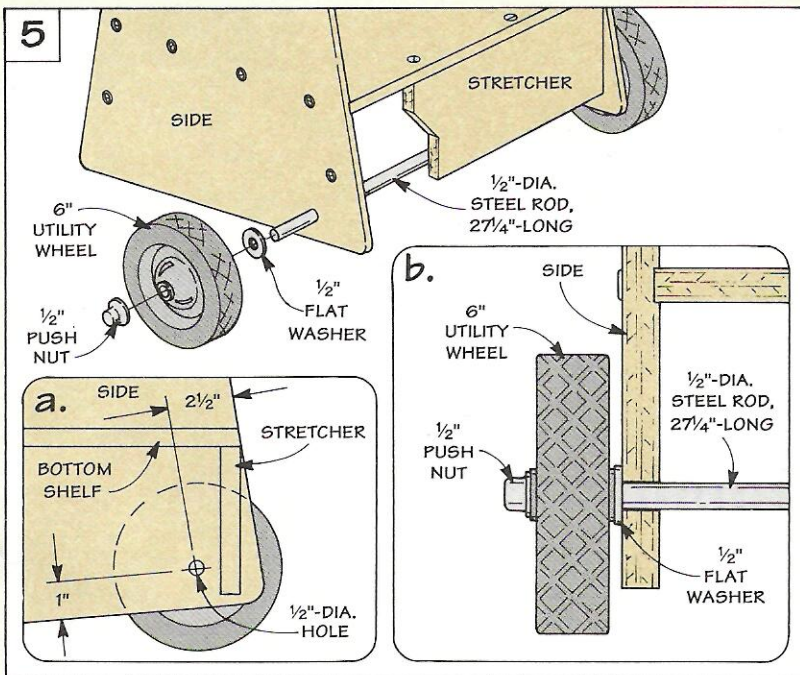

Outfeed Extension

The outfeed extension provides additional support for the workpiece as it exits the planer.

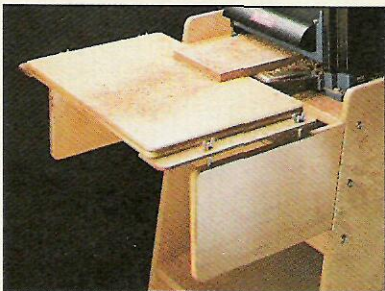

With the planer in place, the next step is to add the outfeed extension, see Fig. 7. It consists of two "wings" and a table to support the workpiece as it exits the planer, see photo. (Note: This extension is designed for planers where the bed stays stationary.)

WINGS

I started on the outfeed extension by making the *outfeed wings* (F), refer to Figs. 7 and 9. They're two rectangular pieces of plywood with one end tapered to match the angle of the stand, refer to Fig. 9.

MOUNT THE WINGS. The wings are attached to the sides with a pair of piano hinges. This allows you to fold them against the sides when you're not using the stand.

The tricky part is locating the wings so the table ends up *flush* with the planer bed. The problem is the location of the tapered sides prevent you from measuring down from the bed of the planer.

To solve this problem, I used a

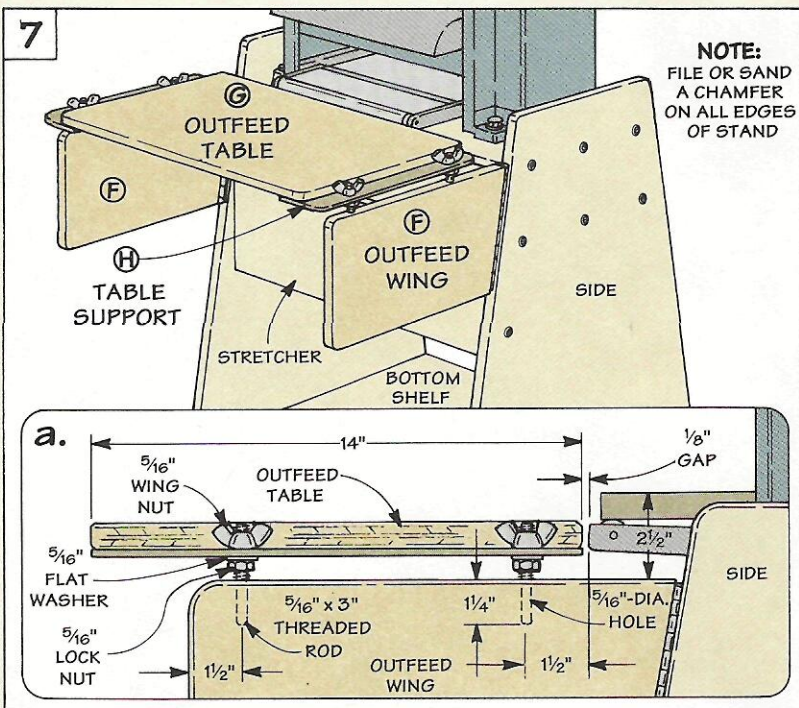

flat board and a framing square, see Fig. 8. The board extends the bed of the planer. And the square allows you to transfer the wing locations to the sides.

Start by unplugging your planer. Then insert a 3/4"-thick board and lower the cutterhead to "clamp" the board in place. Now set your square on the board and make a mark 2 1/2" down on each side.

Finally, line up each wing with your marks and screw the wings to the sides. Note: I used extra-long (1 1/4") screws.

OUTFEED TABLE

Once the wings are in place, the next step is to add the adjustment system and outfeed table.

ADJUSTMENT SYSTEM. The adjustment system holds the outfeed table in place and allows you to adjust it to the correct height for your planer.

The system consists of four pieces of threaded rod (two pieces epoxied in the top edge of each wing), see Figs. 7a and 10. Then, to adjust the height of the

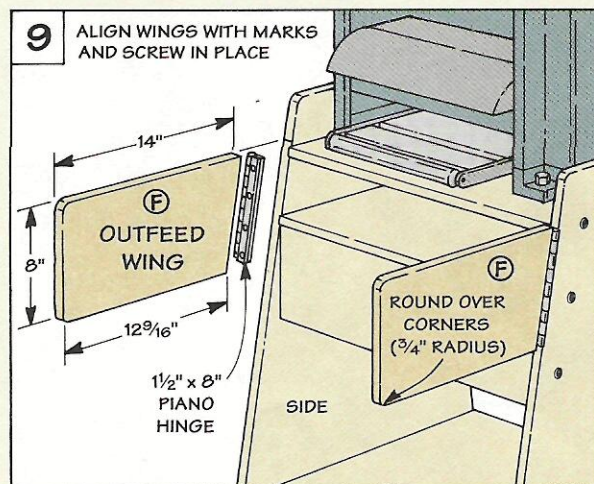
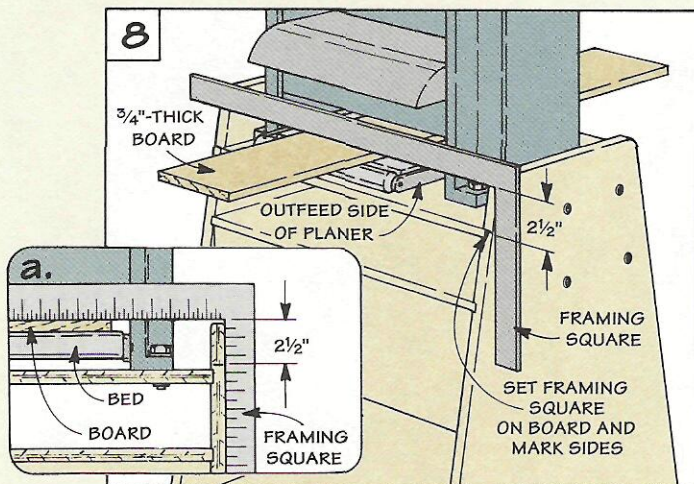
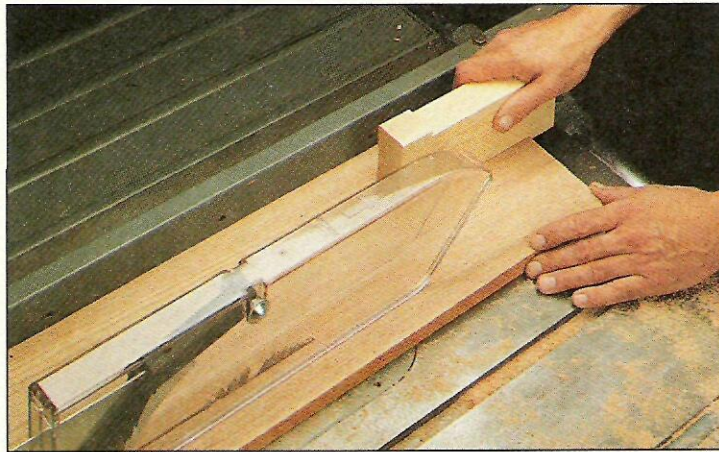

Table Saw: Ripping



How do you prevent binding and kickback? Use the right technique and some simple shop-built accessories.

Ripping stock to width on the table saw is such a common operation that it often becomes instinctive. Set the fence, turn on the saw, and make the cut. But what if the saw binds? Or you need to rip a large or long board?

ADJUSTMENT. The first step to safe, accurate ripping is to make sure your table saw is adjusted properly. With use, the blade and fence can loosen and come out of alignment. It's easy to tell when this happens — the cut binds.

BINDING. Binding occurs when a workpiece is pinched between the saw blade and rip fence. This is caused by a blade and fence

that aren't parallel to each other. To align them, I use a combination square, see photos below.

CHECK LIST. Once the saw is aligned, there are a number of things to check before ripping.

First, take a moment to inspect the wood. To prevent the wood from tilting or rocking as it's cut, make sure it's not warped. And that it's planed flat on one face (for more on this, see page 4) and jointed straight on one edge.

This is also a good time to check your blade guard. Is it positioned and operating properly? (Special Note: The blade guard has been removed for clarity in the draw-

ings shown. You should use the guard whenever possible.) Then slip on your safety glasses and adjust the rip fence.

RULES. There are three simple rules to remember whenever you rip a workpiece.

First: Don't stand directly behind the blade. This way if the stock binds and "kicks back," you're less likely to get injured.

Second: Always follow through — don't let go of the stock until it's completely past the blade.

Third: Feed the workpiece at a steady rate. If you go too fast, the saw can bog down. Too slow and you may burn the workpiece.

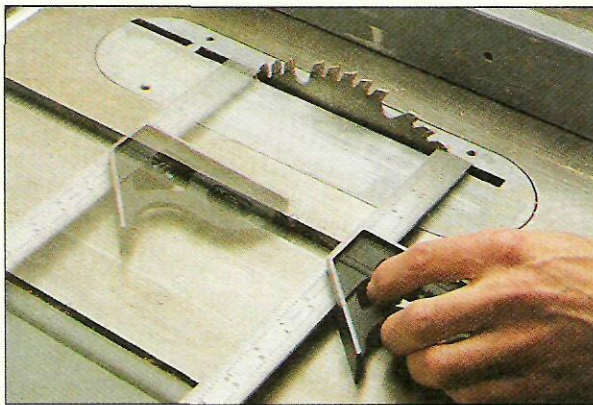

Check Blade. First, place a square in the slot and set it to touch a tooth. Then rotate the blade and push the square to touch the same tooth. If it's not parallel, see your manual to adjust the saw trunnion.

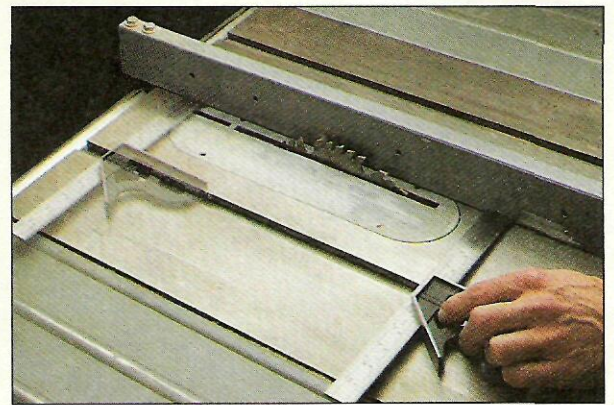

Check Rip Fence. Once the blade is aligned, adjust the square and slide the fence over to touch it. Then, use the same procedure to check if it's parallel. If it's not, see your manual for adjustments.

Accessories

There are a number of simple accessories you can make for your table saw to make ripping safer and more accurate. All the accessories shown below provide you

with more *control* as you rip.

The splitter reduces binding by preventing the saw kerf from closing up on the saw blade. The push block lets you maintain firm

pressure on the workpiece.

The outrigger and the hold-down help control what could be an awkward cut on a large, long, or thin workpiece.

SPLITTER

To prevent the saw kerf from closing on the blade, I made an insert for my saw with a built-in "splitter," see Drawing.

The splitter keeps the kerf open the same width as the blade. To prevent your workpiece from catching on the splitter, sand the end to a point.

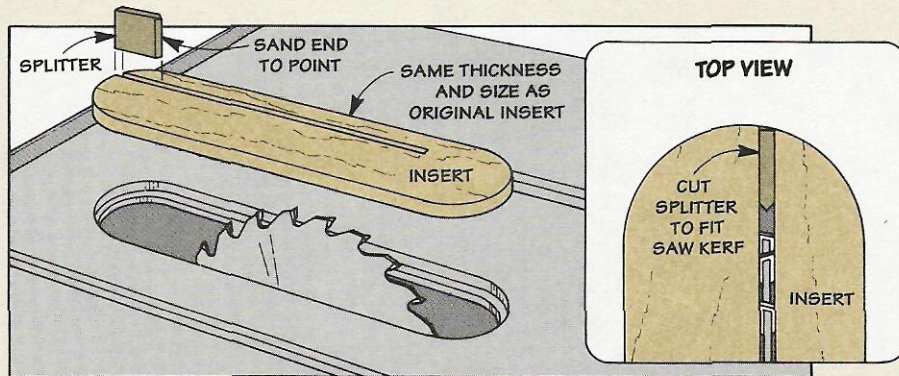

PUSH BLOCK

One of the most important accessories you can use when ripping is a push block. I prefer the type that has a "heel" or lip on the back edge, see Drawing.

The heel pushes both the workpiece *and* the waste through the blade. (This works particularly well when ripping thin strips.)

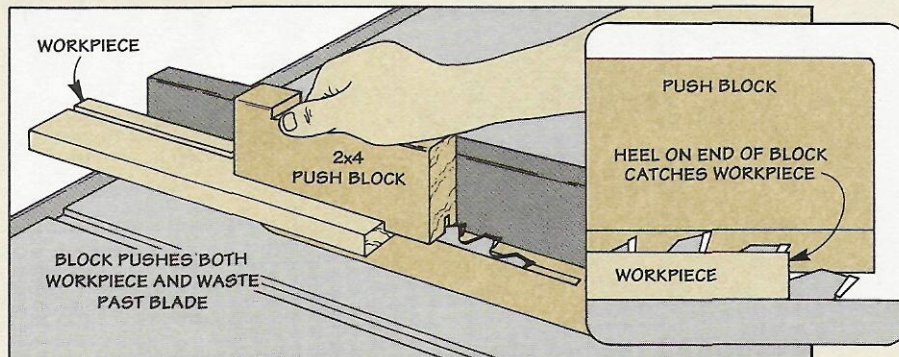

OUTRIGGER

Ripping a long or large workpiece on the table saw can be awkward. To provide additional support to the workpiece, I built a simple "outrigger," see Drawing.

The outrigger clamps to your rip fence and serves as a quick and easy outfeed extension for your table saw.

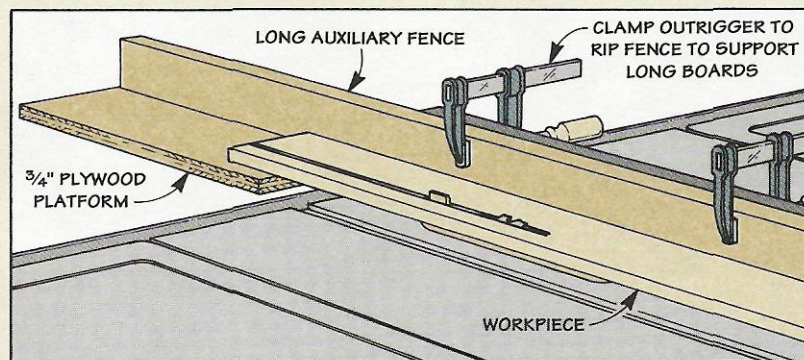

HOLD-DOWN

Ripping thin stock (less than 1/4" thick) on the table saw can be tricky. (Thin stock has a tendency to "ride up" the saw blade and vibrate during the cut.)

To prevent this, I use a scrapwood hold-down, see Drawing. It clamps to your fence and holds the stock flat against the table.

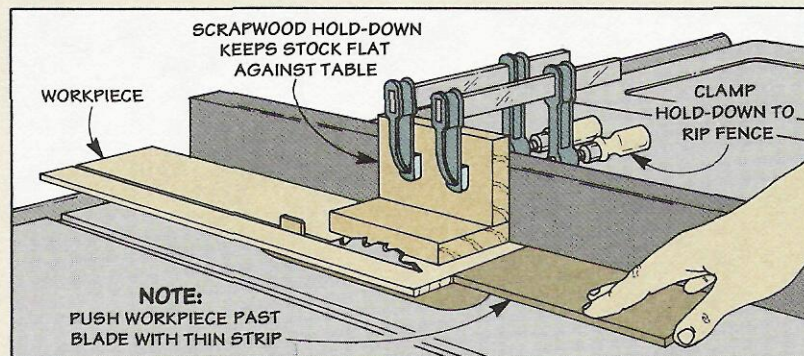

The Case

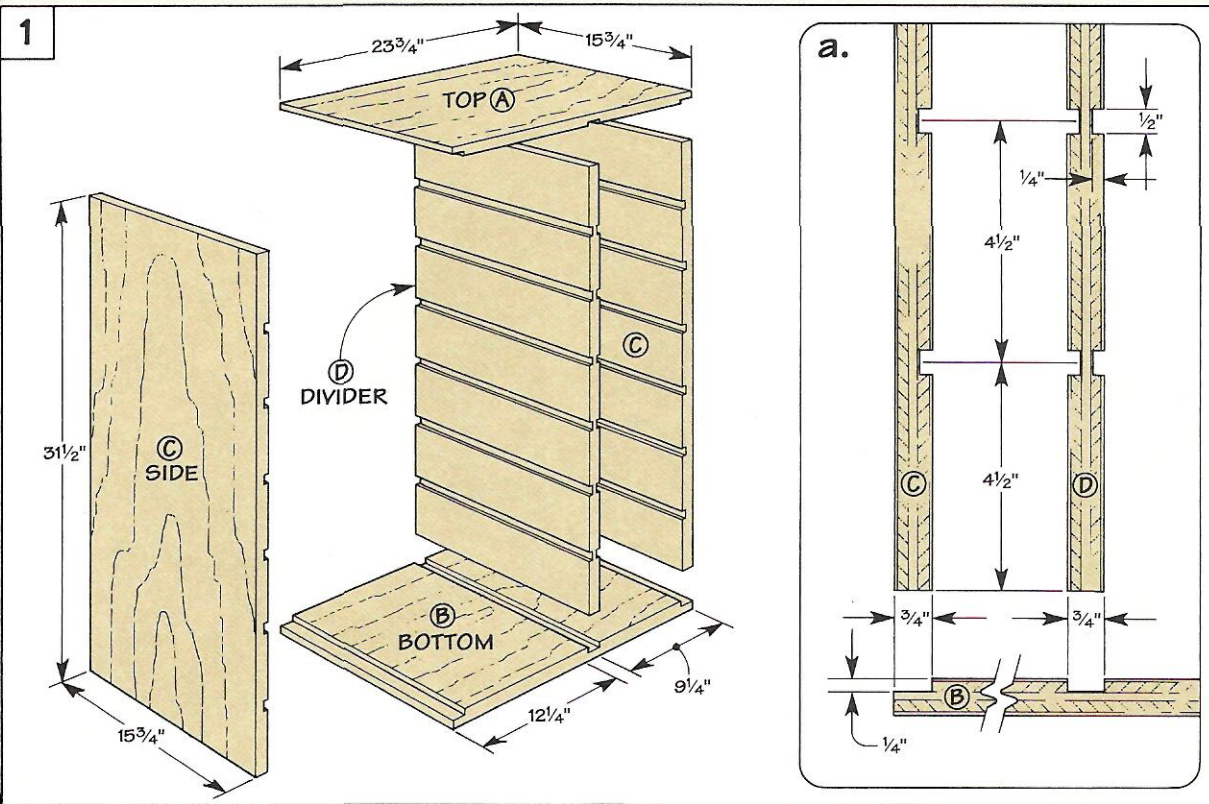

The tool storage system consists of two identical cases. Each case is basically a plywood box with a divider, see Fig. 1.

All of the 3/4"-thick plywood pieces for both cases are cut from a single sheet, see Cutting Diagram. Since these pieces are all the same width (15 3/4"), I started

by ripping the sheet into three 15 3/4"-wide strips.

TOP & BOTTOM. Once the case pieces are cut to width, the *top* (A) and *bottom* (B) pieces can be cut to their finished length (23 3/4"), see Fig. 1.

Then the ends are rabbeted to accept the side pieces, see Fig. 1a.

And a dado is cut in each piece for a divider added later.

SIDES & DIVIDERS. The next step is to cut the *sides* (C) and *dividers* (D) to length (31 1/2"), see Fig. 1. To accept the adjustable shelves (added later), 1/2"-wide dadoes are cut in the *inside* faces of the sides (C), and *both* faces of the dividers (D), see Fig. 1a.

CUT IN PAIRS. That's a lot of dadoes to cut (24 per case). To cut these quickly, I use a special technique. I cut the dadoes in pairs — starting near the ends and working towards the center, see Fig. 2. This cuts your set-up time in half *and* ensures the dadoes will align.

Start by attaching a long auxiliary fence to your miter gauge, see Fig. 2. Then clamp a stop to the fence and cut the first dado. Now just turn the workpiece end for end and cut a second dado.

Do this for both sets of sides and dividers. Note: For the dividers (E), flip the piece over and repeat the cuts on the other side.

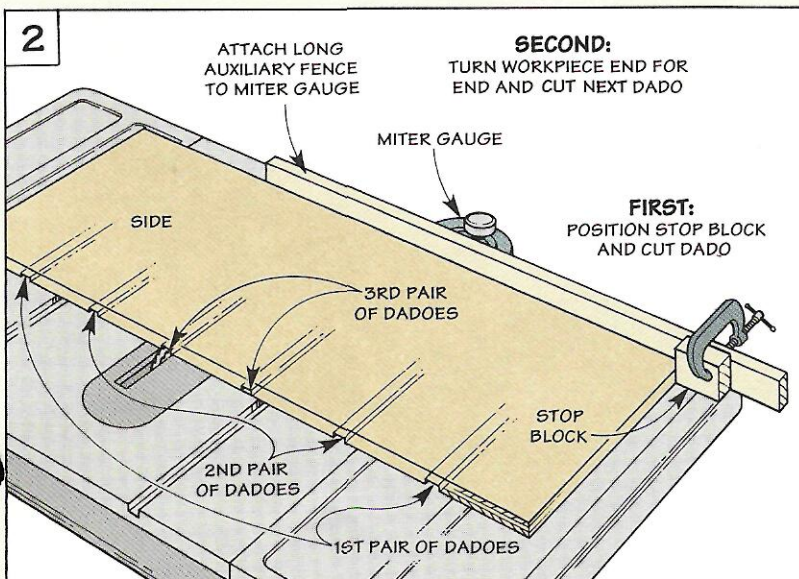

The Back

To strengthen the case and prevent it from racking, I added a $\frac{1}{2}$ " plywood back (E). To hold the back in place, I cut a rabbet on the *inside* edge of the top, bottom, and side pieces (A, B, and C), see Fig. 3.

TRIM DIVIDER. But before you can assemble the case, there's one more thing to do. You'll need to trim $\frac{1}{2}$ " off the width of the divider (D). This way it won't interfere with the back when it's installed later on, see Fig. 3.

ASSEMBLE CASES. Now you're ready to assemble the cases. To do this, apply glue and screw the top and bottom to the sides and divider, see Figs. 3 and 3a.

Note: Make sure that the case is square, and the front of the divider (D) is flush with the front of the case.

ADD THE BACK. Finally, cut a back (E) to fit in the rabbets in each case. Then glue and nail the back in place, see Fig. 3b.

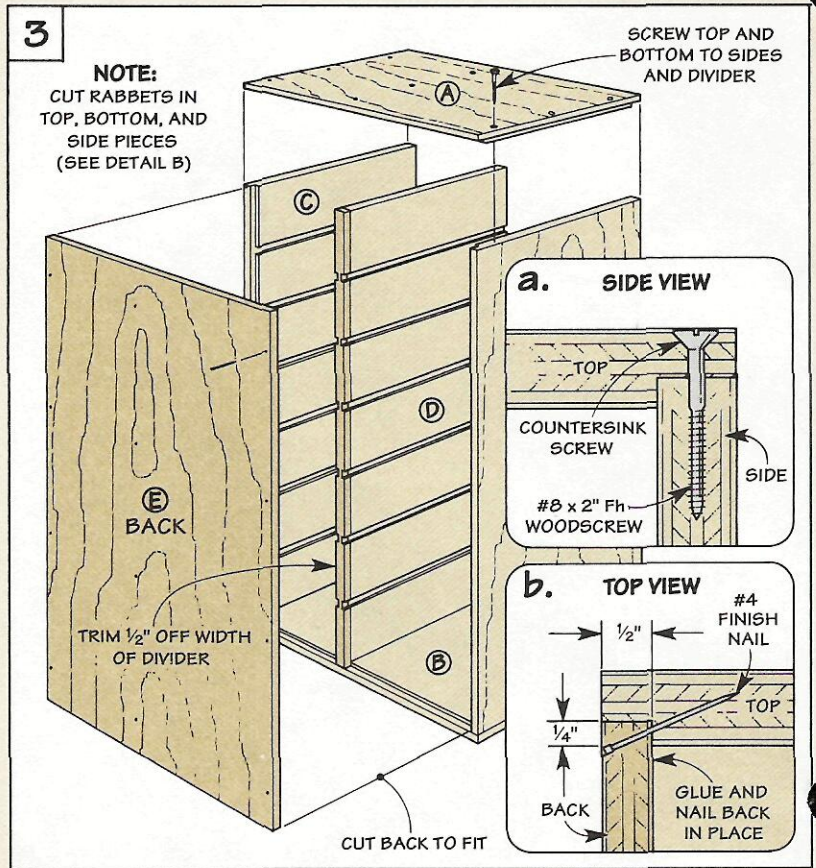

The Base

To make the bottom bin more accessible and keep the case up off a damp floor, I added a base, see Fig. 4.

The base consists of four pieces of 1x4 stock: a front and back (F), and two ends (G). The front and back pieces are rabbeted to accept the ends, see Fig. 4a.

CUT PIECES. The length of the ends is the same ($13\frac{1}{4}$ "). But the length of the front and back depends on how you arrange the cases. If the base is for a single case (or you're going to stack them), the front and back pieces are $21\frac{3}{4}$ " long. If the cases are side by side, they're $45\frac{1}{2}$ " long.

ASSEMBLY. The base is assembled with glue and nails, see Fig. 4a. Then it's centered under the case (this allows a 1" overhang) and screwed in place, see Fig. 4b.

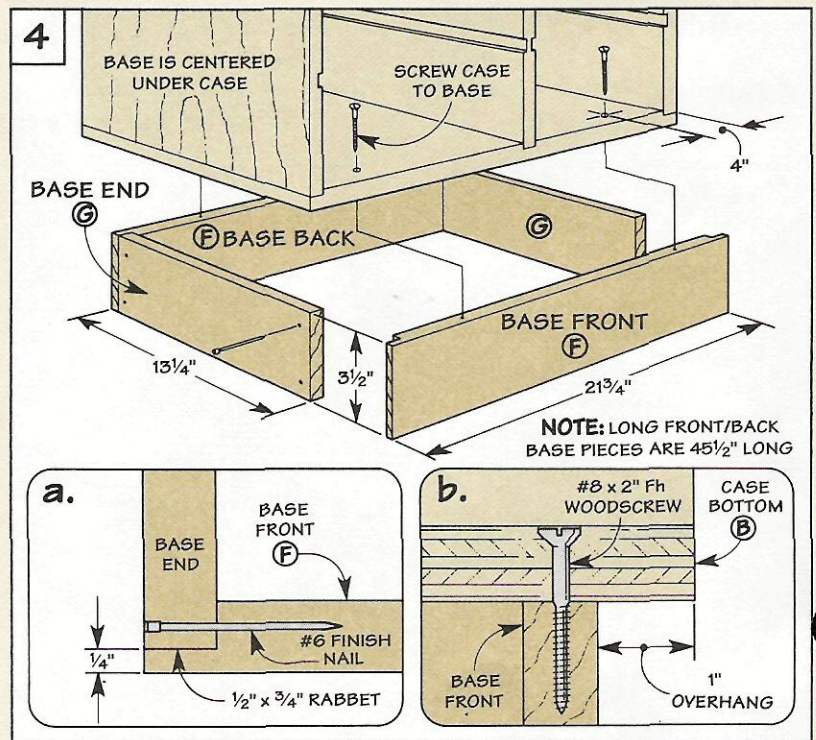

The Shelves

The only thing left to complete the tool storage cases is to add the adjustable shelves, see Fig. 5. These $\frac{1}{2}$ " plywood shelves are cut to fit in between dados in the sides and divider.

TWO SIZES. The depth of the shelves is the same ($15\frac{1}{4}$ "). But the lengths (widths) are different. (Note grain direction.)

In my case, the *wide shelves (H)* are $12\frac{3}{4}$ " long, and the *narrow shelves (I)* are $9\frac{3}{4}$ " long, see Fig. 5 and the Cutting Diagram on page 24.

(Note: The $\frac{1}{2}$ " plywood that remains from cutting the backs (E) will allow for eight shelves of each size.)

To make it easier to slide the shelves in and out, I chamfered the front and back edges of each shelf, see Fig. 5a. Then I beveled (file or sand) the *front edge* of each dado, see Fig. 5a.

CUSTOMIZE SHELVES. Finally, I took the time to customize some of the shelves to hold specific tools, see photos below.

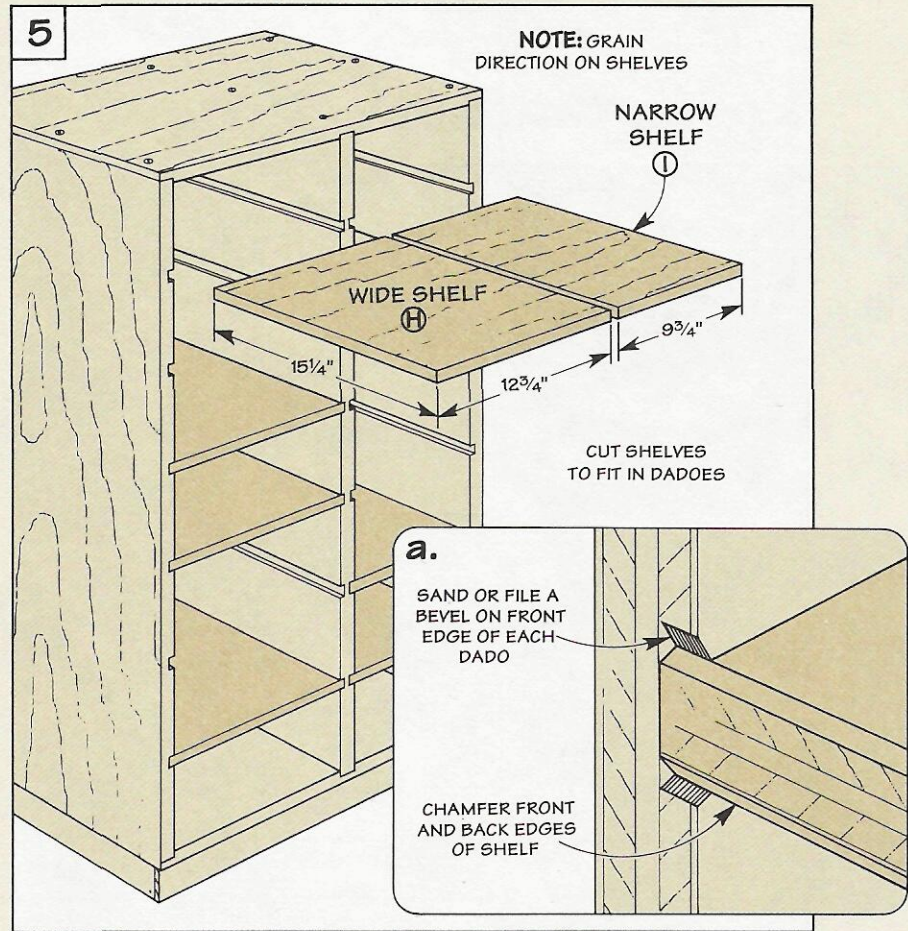

Customizing the Shelves

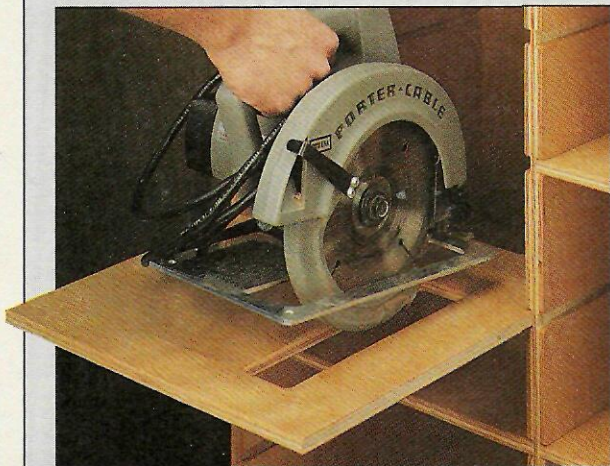

Circular Saw: To keep my circular saw from tilting when I set it on the tool shelf, I cut a long rectangular slot. The slot is cut wide enough to fit the blade guard and allow the saw to sit flat.

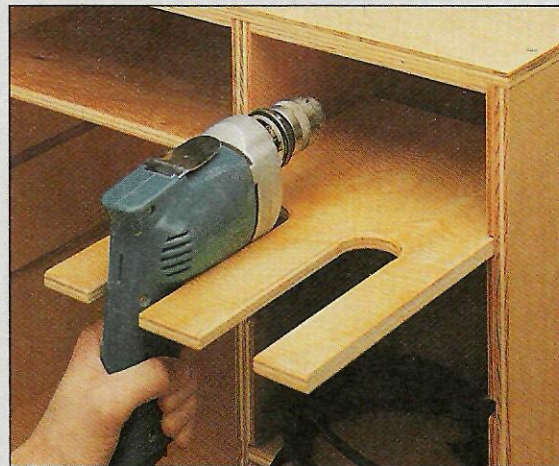

Drills: To make it easy to reach in and grab an electric (or battery powered) hand drill, I notched the front end of one of the shelves. Each notch is cut to fit the handle and holds the drills upright.

Shop Solutions

Router Bit Depth Gauge

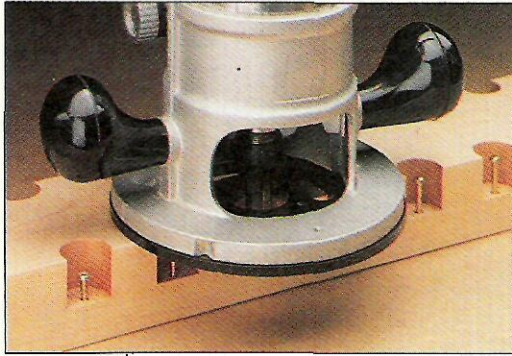

■ Setting the depth of a router bit can involve a lot of trial and error. To get around this, I made a gauge that allows me to precisely set the depth of the bit.

The gauge is made from a short length of 2x4 with a series of brass screws set in half-holes, see Drawing below. The screws can

be “micro-adjusted” to various heights in $\frac{1}{16}$ " increments.

To set a bit, first place the base of the router on the gauge, see photo. Then lower the bit until it just touches the screw that corresponds to the desired depth.

*Lynn B. Stoutner
Ames, Iowa*

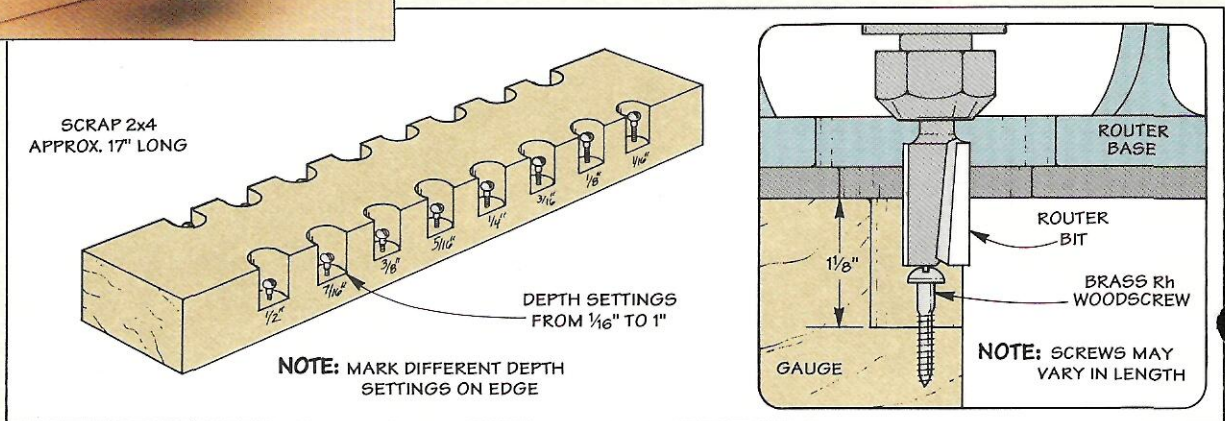

Router Table Adjustment Block

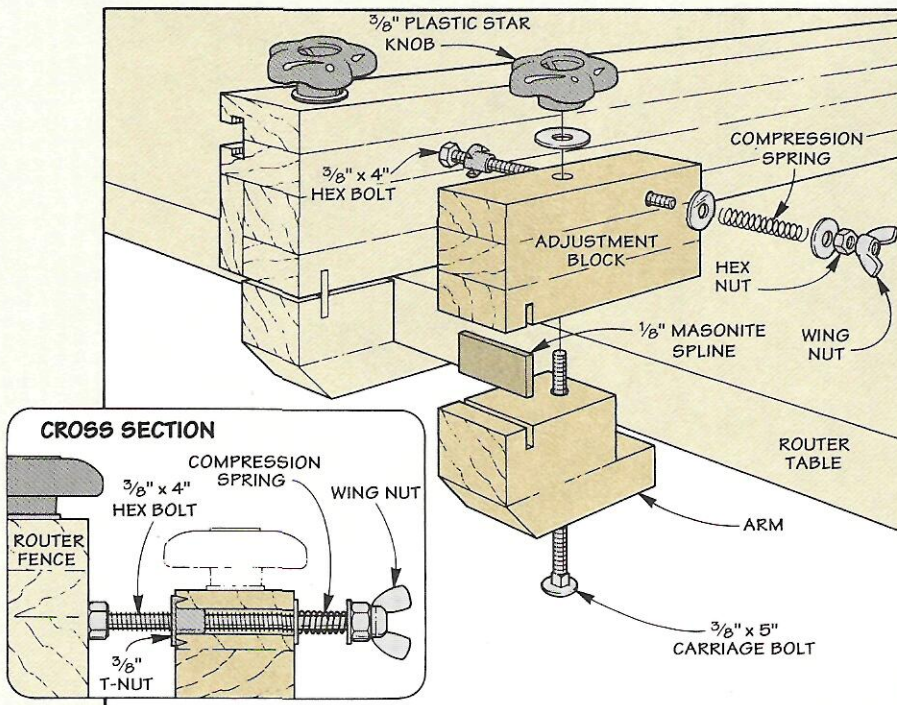

■ There are times when I want to “sneak up” on a final cut on the router table. The problem in doing this is moving the fence in very small increments — and then locking it in place.

To solve this, I clamped an adjustment block behind the fence on my router table. (It clamps to the router table with an L-shaped arm that pinches the table top, see Drawing.)

What makes the whole thing work is a hex bolt that runs through a T-nut in the block. As the bolt is turned, it pushes the fence toward the bit in very small increments. Note: A spring keeps tension on the bolt and prevents it from vibrating loose.

*Nick Yinger
Concord, California*

Installing Threaded Inserts

■ I use a cut-off bolt in a drill press to install threaded inserts. But sometimes in hard woods it can be difficult to turn the chuck by hand.

To get a better grip and apply more torque, I thread a large plastic wing nut onto the bolt, see Fig. 1. The wing nut allows me to use my fingers and thumb to turn the bolt — and give me more leverage to go into the hard wood.

This technique also works great for installing hanger bolts, see Fig. 2. (Just be sure to drill a pilot hole first.)

*Mark Sanner
Old Saybrook, Connecticut*

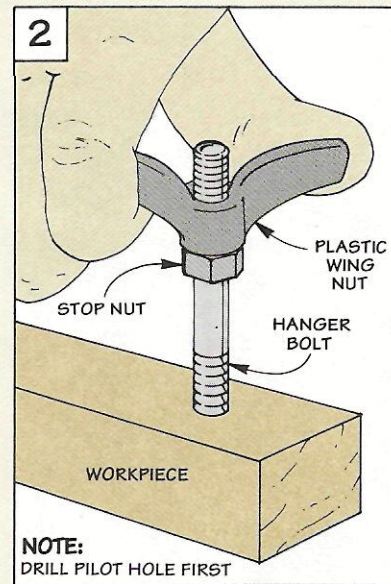
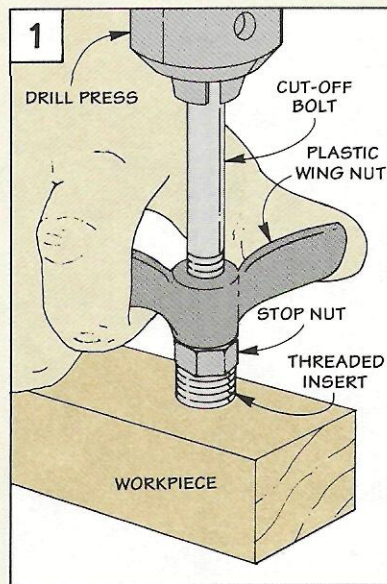

Squaring-Up Large Panels

■ Squaring-up a large glued-up panel on the table saw can be a challenge. Especially if the panel is too large to be supported by the miter gauge. And the ends of the panel are uneven so you can't run them along the rip fence.

The solution is to "fool" the rip fence. One way of doing this is to attach a board along the edge of the panel. But this doesn't ensure a perfect 90° cut. The method I use does. And all that's required is a framing square.

Just carpet tape the framing square flush with the panel's edge so it overhangs the uneven end

slightly, see Drawing.

Then butt the square up against the rip fence to make the cut. Once one end is squared up,

remove the framing square and cut the opposite end.

*Mark Klein
Cardiff-by-the-Sea, California*

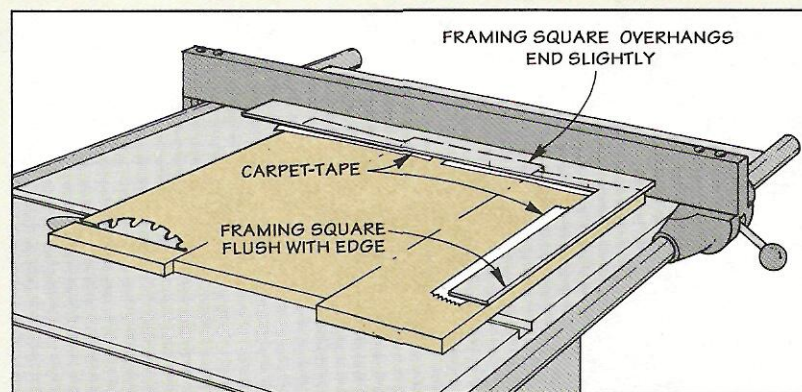

Cork-Bottom Sanding Block

■ Adhesive-backed sandpaper (like 3M's Stikit) and a piece of wood make a great sanding block. The only problem is it's difficult to remove the sandpaper. To prevent this, I glued a piece of cork to the bottom of the block. The cork is porous enough so you can peel the sandpaper right off.

*Thomas E. Bussey
Cedar Falls, Iowa*

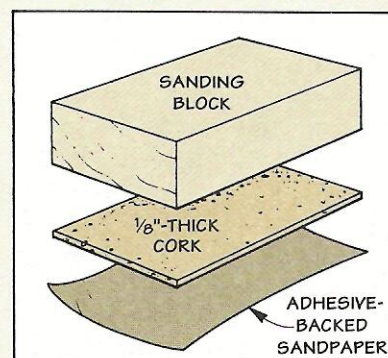

Send in Your Solutions

If you'd like to share original solutions to problems that you've faced, send them to: *ShopNotes*, Attn: Shop Solutions, 2200 Grand Avenue., Des Moines, IA 50312.

We'll pay up to \$200 depending on the published length. Send an explanation along with a photo or sketch. Include a daytime phone number so we can call you if we have questions.

Lumber Grades

■ I've noticed that hardwood lumber is often priced according to its "grade." And the price difference between grades can be considerable. What exactly am I paying for?

Milo Keen
Adel, Iowa

Understanding the different grades of lumber can save you money.

No matter what grade of lumber you buy, all you're paying for is the amount of "usable" wood in each board. This is determined by a professional grader at a mill or lumber yard and is based on what the National Hardwood Lumber Association (NHLA) calls a "clear face cutting."

A clear face cutting is a portion of a board that has one clear or defect-free face and the reverse side is free from unsound defects (such as rot or loose knots). The number and the size of these cuttings will determine the grade of the board.

GRADES

This means the grader has to look at *both* sides of the board to determine which is the good side and which is the poor side.

FAS. For example, the top grade, *FAS* (firsts and seconds) is graded from its *poorest* face. The thought here is that a board is only as good as its poorest face. A board that's graded *FAS* will yield slightly more than 83% clear wood.

SELECT. The next grade, *Select*, will also yield at least 83% clear wood. The difference is a select board is graded from the *good* face. It's basically a combination grade: the good side must grade *FAS*,

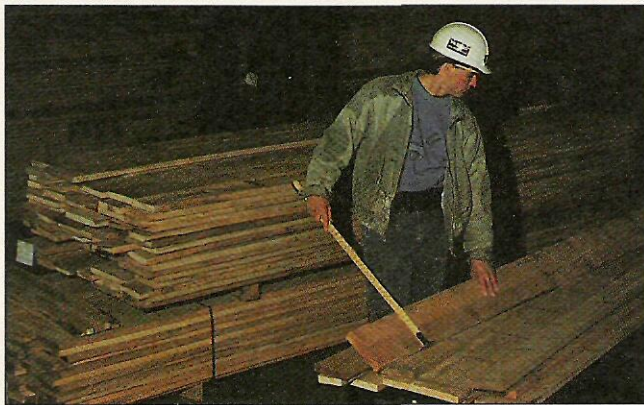

▲ The lumber grader checks each board as it comes off a pallet. He flips the board to look at both faces and then uses a set of lumber guidelines to assign a grade.

and the reverse side allows some slight defects (No. 1 Common).

Boards that are graded *Select* can be used whenever you only need one good face — like the top for a dining room table. You could use *FAS*, but you'd be paying a lot more for wood you'll never see.

NO. 1 COMMON. Like *FAS*, *No. 1 Common* boards are also graded from the poor side — but with more waste. You can only expect about 66% of the board to be clear.

Lower grades of hardwood (2A, 2B, 3A, and 3B) are not readily available. They're generally used by manufacturers to make flooring, pallets, and other wood products.

BOARD SIZE. In addition to the amount of clear wood, the NHLA also sets standards for the overall *size* of a board being graded. For instance, a *FAS* board *must* be at least 6" wide and 8 feet long. While a *No. 1 common* board only has to be 3" wide and 4 feet long.

The important thing to remember is that the *quality* of clear stock in a *No. 1* board is equal to that of a *FAS* board. The only difference is the size (or amount) of the clear cuttings that can be obtained from the board.

BUYING TIPS

So what does all this mean to a woodworker? It means you can save money when you buy lumber if you know the amount of clear wood each grade will yield.

For instance, let's say I'm looking to buy 100 board feet of $\frac{3}{4}$ " red oak. And the *FAS* price is around \$3.00 a board foot. For \$300 I'll get around 83 board feet of clear lumber.

However, if I purchased 125 feet of *No. 1 Common* red oak at \$1.20 a board foot, I'd get about the same amount of clear wood for only \$150 — a savings of \$150.

So I only buy *FAS* when I need long, clear stock. If I need short narrow boards, I save money by buying *No. 1 Common*.

NHLA HANDBOOK. A final note. If you'd like more information about grading, the NHLA (P.O. Box 34518, Memphis, Tennessee 38184) publishes a grading handbook. It costs \$6.00 and reads like income tax instructions — but it contains a wealth of information.

Lumber Questions?

Identifying, selecting, and buying materials for your workshop projects can be a bit confusing.

If you have any questions about lumber or other project materials, send them to: *ShopNotes*, Attn: Lumberyard, 2200 Grand Ave., Des Moines, IA 50312.

Please include a daytime phone number so we can call you if necessary.

Sources

ShopNotes Project Supplies is offering some of the hardware and supplies needed for the projects in this issue.

We've also put together a list of other mail order sources that have the same or similar hardware and supplies.

VERTICAL RAISED PANEL JIG

The shop-built Vertical Raised Panel Jig (shown on page 6) attaches to your router table and makes it easy to rout a decorative raised panel.

Note: The Vertical Raised Panel Jig is sized to fit the Router Table featured in *ShopNotes* No.1. But it can easily be sized to fit any other router table.

ShopNotes Project Supplies is offering a hardware kit that includes all the hardware needed to make the Vertical Raised Panel Jig. All you need to supply is the plywood and 1/4"-thick Masonite.

S6809-100 Vertical Raised Panel Jig Hardware Kit..\$12.95

BITS. What sets this jig apart from other raised panel jigs is the bits used to rout the profile — vertical raised panel bits (see Mail Order Sources below).

On a vertical raised panel bit,

the cutting edges are oriented *vertically*. This means you need to stand the workpiece on *edge* to rout a profile, instead of laying it flat on the router table.

FEATHERBOARD. To rout a consistent profile, it's important that the workpiece be held tight against the jig's fence. One way to do this is to use featherboards. *ShopNotes Projects Supplies* is offering a polycarbonate featherboard separately. (This is the same featherboard we used on the Router Table in *ShopNotes* No. 1.)

S4502-525 Featherboard (two required).....\$14.95ea.

PORTABLE PLANER STAND

One way to make your "portable" planer *truly* portable is to mount it to the Planer Stand shown on page 16. In addition to offering mobility, this stand features an adjustable outfeed extension and an optional drawer.

The outfeed extension provides support to a workpiece as it exits the planer. And the optional drawer is a handy place to store all your planer accessories.

ShopNotes Project Supplies is offering a hardware kit for the Portable Planer Stand. The kit

includes all the hardware to build the stand, along with the 6" rubber utility wheels.

We've also included the bullet catches and screws for the optional drawer. All you need to supply is the plywood and 1/4"-thick Masonite. Note: You'll also need to supply the correct size mounting bolts and T-nuts to attach the planer to the stand.

S6809-200 Planer Stand Hardware Kit \$29.95

EDGEBANDING

Edgebanding (or veneer edging) is one of the quickest and easiest ways to hide a plywood edge.

There are three basic types of edgebanding: glue-on edging, iron-on veneer, and veneer tape. They're all just thin strips of wood. The difference is how they're applied to a plywood edge.

Edgebanding is available at some hardware stores and home centers. It's also available from the Mail Order Sources below.

One challenge to working with edgebanding is trimming the veneer after it's applied. Edge trimmers are designed just for this and do a great job. If you can't find them locally, see sources below.

MAIL ORDER SOURCES

Similar hardware and supplies may be found in the following catalogs. Please call each company for a catalog or for ordering information.

Constantine's

800-223-8087
Veneer Edging, Edge Trimmers, Dry Lubricants

Highland Hardware

800-241-6748
Veneer Edging, Dry Lubricants

Trendlines

800-767-9999
Veneer Edging, Edge Trimmers

Woodhaven

800-344-6657
Vertical Raised Panel Bits, Router Maintenance Kit

Woodcraft

800-225-1153
Veneer Edging, Vertical Raised Panel Bits, Dry Lubricants

Woodworkers Supply

800-645-9292
Veneer Edging, Edge Trimmers, Dry Lubricants

The Woodworkers' Store

612-428-3200
Edge Trimmers, Veneer Edging, Vertical Raised Panel Bits

ORDER INFORMATION

BY MAIL

To order by mail, use the order form that comes with the current issue. The order form includes information on handling and shipping charges, and sales tax.

If the mail order form is not available, please call the toll free number at the right for more information on specific charges and any applicable sales tax.

BY PHONE

For fastest service use our Toll Free order line. Open Monday through Friday, 7:00 AM to 7:00 PM Central Time.

Before calling, have your VISA, MasterCard, or Discover Card ready.

1-800-444-7527

Note: Prices subject to change after July 1, 1993.

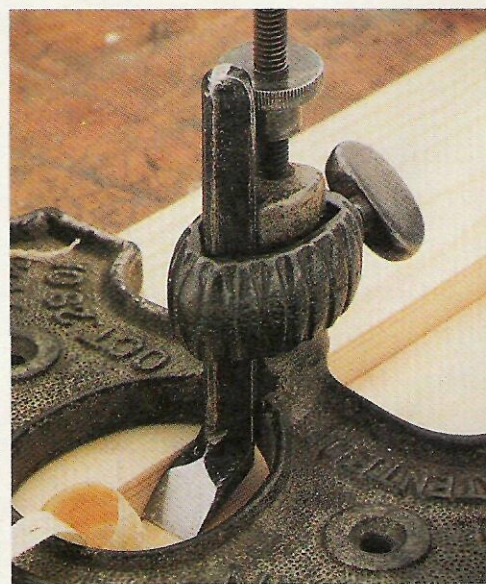
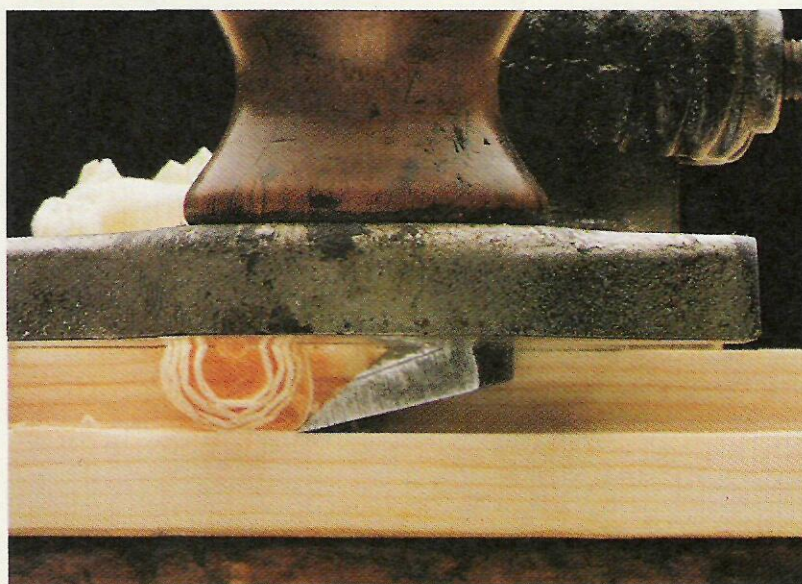
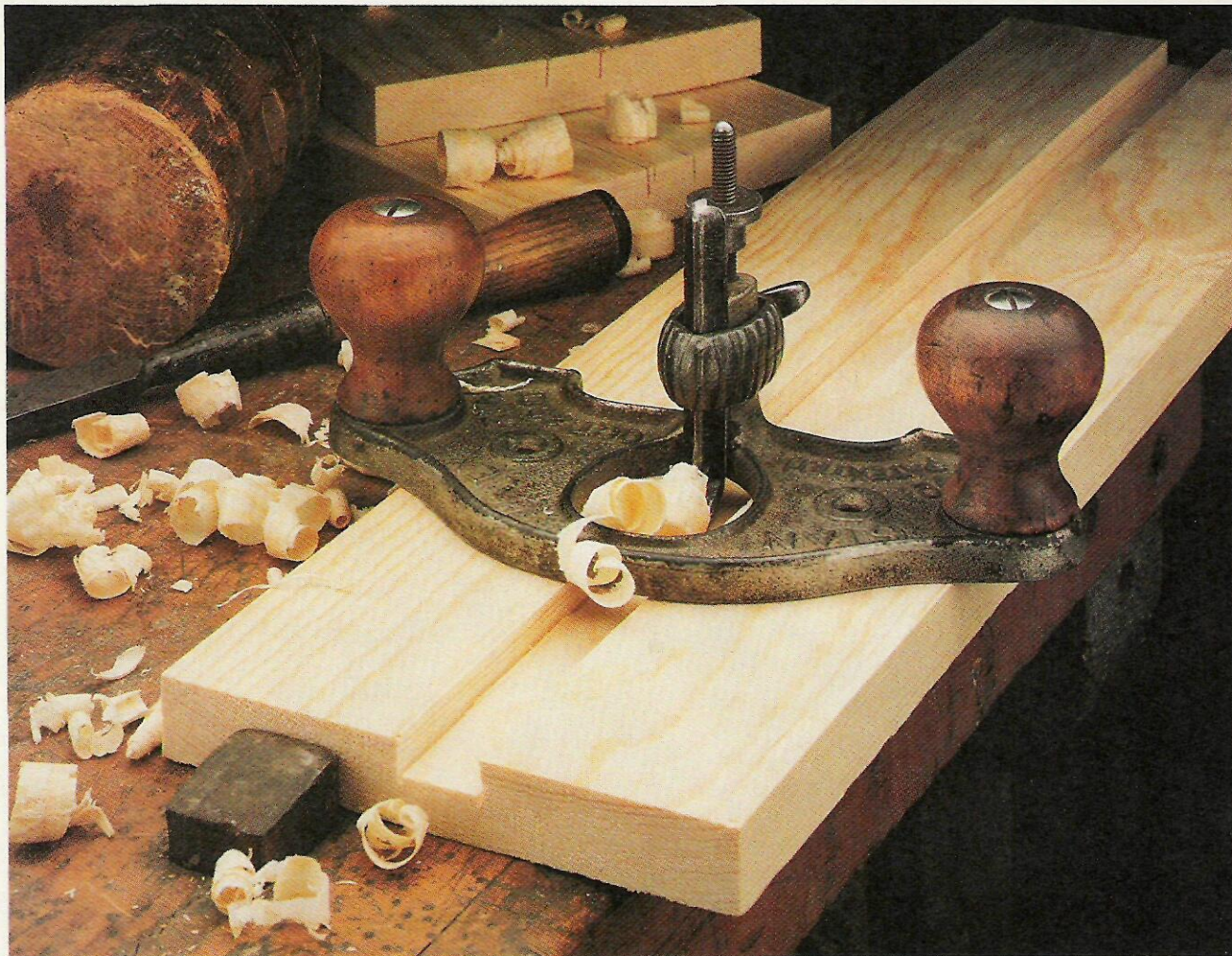

Scenes From the Shop

This Stanley No. 71½ Router Plane was used to create flat-bottomed grooves and dados. First, the sides were cut with a hand saw. Then the rough waste was removed.

(This could have been done with the router plane, but it was often faster to use a chisel.) Finally, the router plane was used to flatten the bottom of the groove.