

TIPS • TOOLS • TECHNIQUES

ShopNotes®

Vol. 2

Issue 10



- Heavy-Duty Lathe Stand
- Cutting Perfect Miters
- Router Table Indexing Jig
- Layout Techniques

EDITOR Donald B. Peschke
EXECUTIVE EDITOR Douglas L. Hicks
MANAGING EDITOR Terry J. Strohmman
ASSOCIATE EDITOR Richard S. Peters
ASSISTANT EDITOR Tim Robertson
CONTRIBUTING EDITOR Philip A. Totten

CREATIVE DIRECTOR Ted Kralicek
ART DIRECTOR Cary Christensen
SENIOR ILLUSTRATOR Kurt Schultz
ILLUSTRATORS Will Niskanen
 Roger Reiland
 Mark Higdon
PHOTOGRAPHER Crayola England

DESIGN DIRECTOR Ken Munkel
SENIOR DESIGNER Jan Hale Svec
DESIGNER Kent Welsh
SHOP MANAGER Steve Curtis

CIRCULATION

Circulation Director: Liz Bredeson • *Subscription Manager:* Phyllis Jessen • *Circulation Analyst:* Rod Cain • *Newsstand Sales:* Kent A. Buckton

PUBLISHING SERVICES

Associate Editor: Gordon C. Gaippe • *Sr. Graphic Designer:* Robert H. Whitmer

CORPORATE SERVICES

Controller: Paul E. Gray • *Accounting:* Laura Thomas • *Bookkeeping:* Julianne Spears • *Info. Services Manager:* Joyce Moore • *Electronic Pub. Coordinator:* Douglas M. Lidster • *Administrative Assts.:* Cheryl Scott, Julia Fish • *Receptionist:* Jeanne Johnson • *Bldg. Maint.:* Ken Griffith

PROJECT SUPPLIES

Marketing Director: Robert Murry • *Catalog Art Director:* Cindy Jackson • *Catalog Products Manager:* Bob Baker • *Project Supplies:* Linda Jones • *Technical Support:* Jeff Fish • *Systems Operator:* Linda Morrow • *Receptionist:* Keri Lee

CUSTOMER SERVICE

Manager: Valerie Wiese • *Supervisor:* Jennie Enos • *Customer Service Representatives:* Jennifer Murphy, Joy Johnson, Sara Kono, Ami Blanshan, Anna Cox, Chris Lo

SHIPPING DEPARTMENT

Supervisor: Jerry Carson • *Fulfillment:* Gloria Sheehan, Don McVey, Chuck Carlson, Sylvia Carey

ShopNotes® (ISSN 1062-9696) is published bimonthly (Jan., March, May, July, Sept., Nov.) by Woodsmith Corporation, 2200 Grand Ave., Des Moines, IA 50312. ShopNotes® is a registered trademark of Woodsmith Corp. ©Copyright 1993 by Woodsmith Corporation. All rights reserved.
 Subscriptions: Single Copy, \$4.95. One year subscription (6 issues), \$19.95. Two years (12 issues), \$35.95. Canada/Foreign, add \$4.00 per year.
 Second Class Postage Paid at Des Moines, IA and at additional offices.
 Postmaster: Send change of address to ShopNotes, Box 11204, Des Moines, IA 50340-1204
 Subscription Questions? Call 1-800-333-5854, 8am to 5pm, Central Time, weekdays.

PRINTED IN U.S.A.

I'm often asked, "Isn't it difficult to come up with new project ideas?" The answer is no — coming up with ideas is easy. The tricky part is working out the details.

The job of working out these details falls on the shoulders of the ShopNotes Design Department (Ken Munkel, Jan Svec, and Kent Welsh).

Sometimes everything about a project falls into place and there are very few problems. But more often, designing projects takes lots of hard work and a fair amount of hair pulling. In fact, Ken Munkel (our Design Director) has almost run out of hair to pull.

LATHE STAND. The Lathe Stand on page 16 is a good example of a project that went together smoothly. The idea was to build a sturdy stand that would absorb the vibration of a bench-top lathe. Within a few days we had ironed out the details and were ready to start building the stand.

The secret to absorbing the vibration of the lathe was to make the stand as heavy as possible. So we made the top and the legs from heavy "slabs" of particleboard and Masonite.

Then, to prevent the stand from racking from side to side, we needed to "tie" the legs together. We were also worried that the stand would be top-heavy once the lathe was mounted.

Here again the solution was simple. We connected the legs with a hollow beam. This prevents the stand from racking. And filling the beam with sand adds weight and keeps the stand from being top-heavy.

Like I said before, designing and building the Lathe Stand went rather smoothly. However it was a different story for the Indexing Jig on page 4.

INDEXING JIG. The idea for this jig came about while I was routing a series of grooves in a workpiece. After each pass I had to readjust the fence and

"tweak" it into position. What I needed was a jig that would allow me to position the fence on a router table in precise increments. But I also wanted some sort of micro-adjuster so I could "fine-tune" the fence. Doesn't sound too complicated, right? Well, talking about a jig is one thing — getting it to work is altogether different.

Designing the Indexing Jig was like knocking down a row of dominoes. The solution to one problem created another problem later on.

For instance, to "index" the fence in precise increments, we used a threaded rod and a coupling nut. But then we needed a way to "lock" these parts together and still be able to position them quickly. The solution was a spring-loaded hold-down. But this caused another problem. And so on...

The good news is that the Indexing Jig turned out even better than I had hoped. In fact, several people here have already started building this jig for their router table at home.

DRILL BIT CASE. Another project that's real popular around here is the Drill Bit Case, see page 10. The unusual thing is the Drill Bit Case didn't start out as a project for the magazine. I made it for myself.

A few days later, I noticed several versions of the Drill Bit Case had appeared in the shop. That's when I decided to feature it in this issue.

HELP WANTED. We're looking for a full-time editor to join our staff here in Des Moines. Candidates should have a first-hand knowledge of woodworking, and a background in writing and communicating ideas. If you're interested, write us a letter explaining what you've been doing in the areas of woodworking and writing.

Send your letter to Doug Hicks, Executive Editor, 2200 Grand Ave., Des Moines, IA 50312. He'll get back to you.

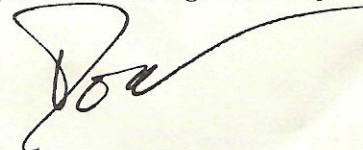

Contents

Indexing Jig _____ 4

This jig for your router table lets you quickly and accurately position the fence. The fence can be moved in precise 1/16" increments or fine-tuned for an exact cut.

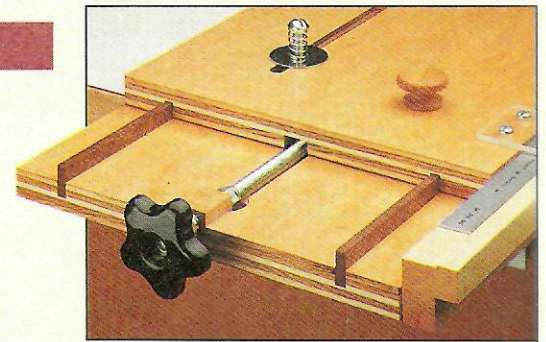

Indexing Jig page 4

Drill Bit Case _____ 10

Protect and organize your twist drill bits with this simple case made from wood salvaged from the scrap bin.

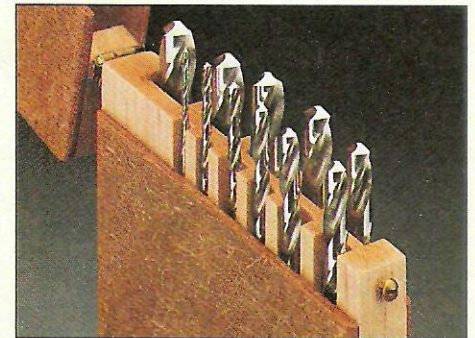

Drill Bit Case page 10

Perfect Miters _____ 12

All it takes to cut perfect miters on the table saw is a few basic adjustments and our simple cutting sequence.

Lathe Stand _____ 16

A heavy bench with a unique sand-filled beam virtually eliminates lathe vibration. Two drawers keep lathe accessories handy. There's even plans for an optional tool rack.

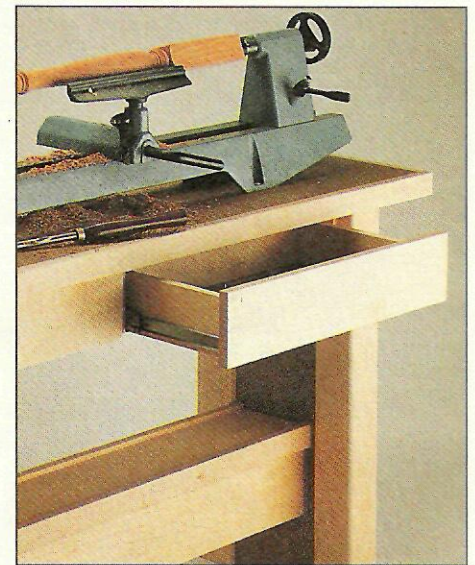

Lathe Stand page 16

Layout Techniques _____ 22

Practical tips and techniques to increase accuracy and simplify measuring and layout.

Sanding Products _____ 26

A look at new sanding products. New types of abrasives. New sanding belts. Even "metal sandpaper."

Shop Solutions _____ 28

Six Shop-Tested Tips: Pipe Clamp Edge Vise, Supports for Cutting Plywood, Auxiliary Band Saw Fence, a Tip for Rust Removal, Glue Brush Tip, and a Shop-Made Cord Tie.

Full-Extension Drawer Slides _____ 30

Adding a pair of full-extension slides is an easy way to increase the usable space of a drawer, tray, or shelf.

Sources _____ 31

Hardware, project supplies, and mail order sources for the projects in this issue.

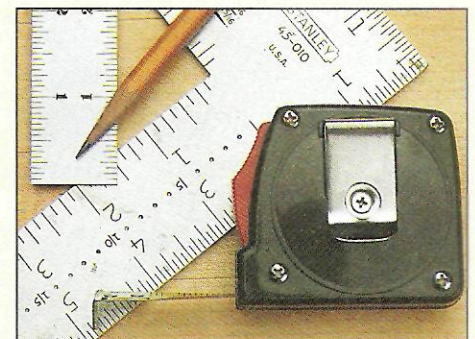

Layout Techniques page 22

Indexing Jig

This shop-made jig eliminates the guesswork when adjusting your router table fence for exact cuts.

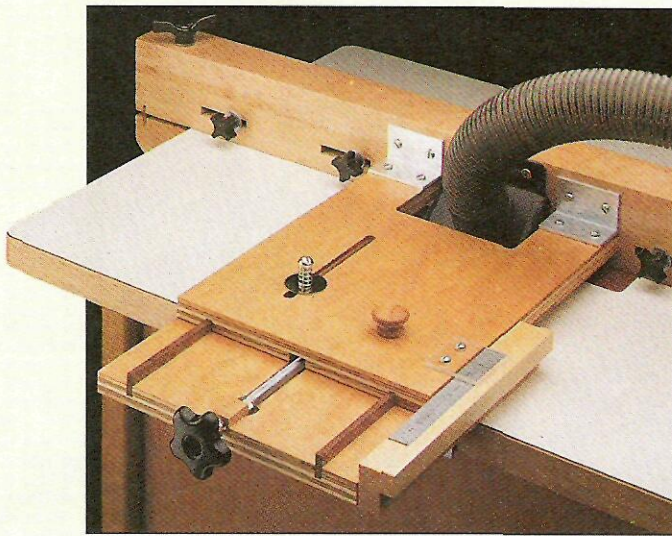

Accuracy. That's the idea behind this micro-adjustable Indexing Jig. It lets you quickly and accurately position the fence on your router table, see photo.

The indexing feature allows you to move the fence in exact $\frac{1}{16}$ " increments and always come back to the *same* setting. This makes it easy to accurately locate grooves and rabbets.

The micro-adjustable feature virtually eliminates guesswork. No more time spent tapping one end of your fence to "sneak up" on a cut. Now you can "dial in" the fence to the perfect setting.

Note: This jig requires 10" to 18 $\frac{1}{2}$ " of space from the center of the bit to the *back* of the table top.

CONSTRUCTION

The indexing jig consists of two basic parts: a base that mounts to your router table, and a sliding platform that attaches to your fence, refer to Exploded View.

GROOVES. To allow the platform to slide on the base without twisting, grooves are cut in both pieces for two $\frac{1}{4}$ "-thick Masonite guide strips, refer to Fig. 2.

To make sure the grooves align in both pieces, start with an extra-long blank (10" x 25") and cut the grooves first, see Fig. 1.

Then trim the *base* (A) and *sliding platform* (B) to their finished lengths, see Fig. 1. Note: A cut-out in one end of the sliding platform provides clearance for a dust hood, see Fig. 2.

THREADED ROD. The next step is to cut a centered groove in the base and sliding platform for a threaded rod and a coupling nut that form the indexing system (these parts are added later), see Fig. 2. The width of each groove

is the same ($\frac{5}{8}$ "). But their depths are different, see Fig. 2a.

GUIDE STRIPS. Finally, two $\frac{3}{4}$ "-tall (wide) Masonite *guide strips* (C) are cut to match the length of the base (10") and then glued in the base, see Fig. 2.

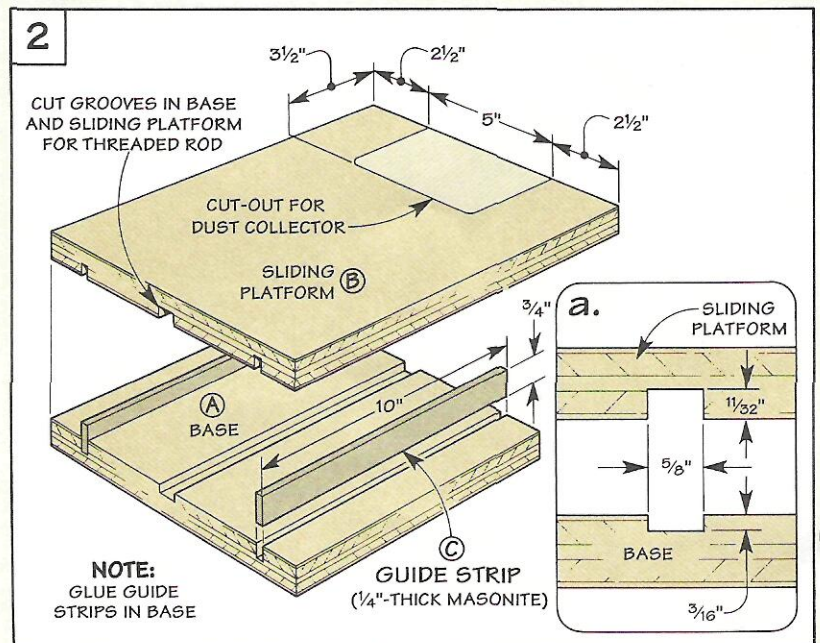
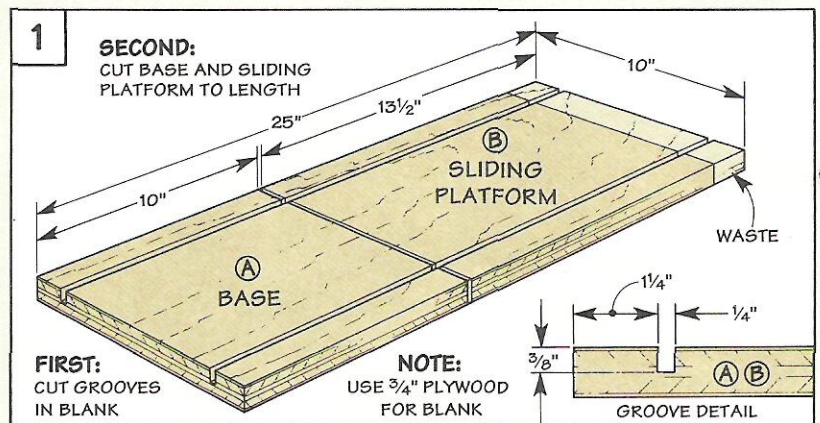

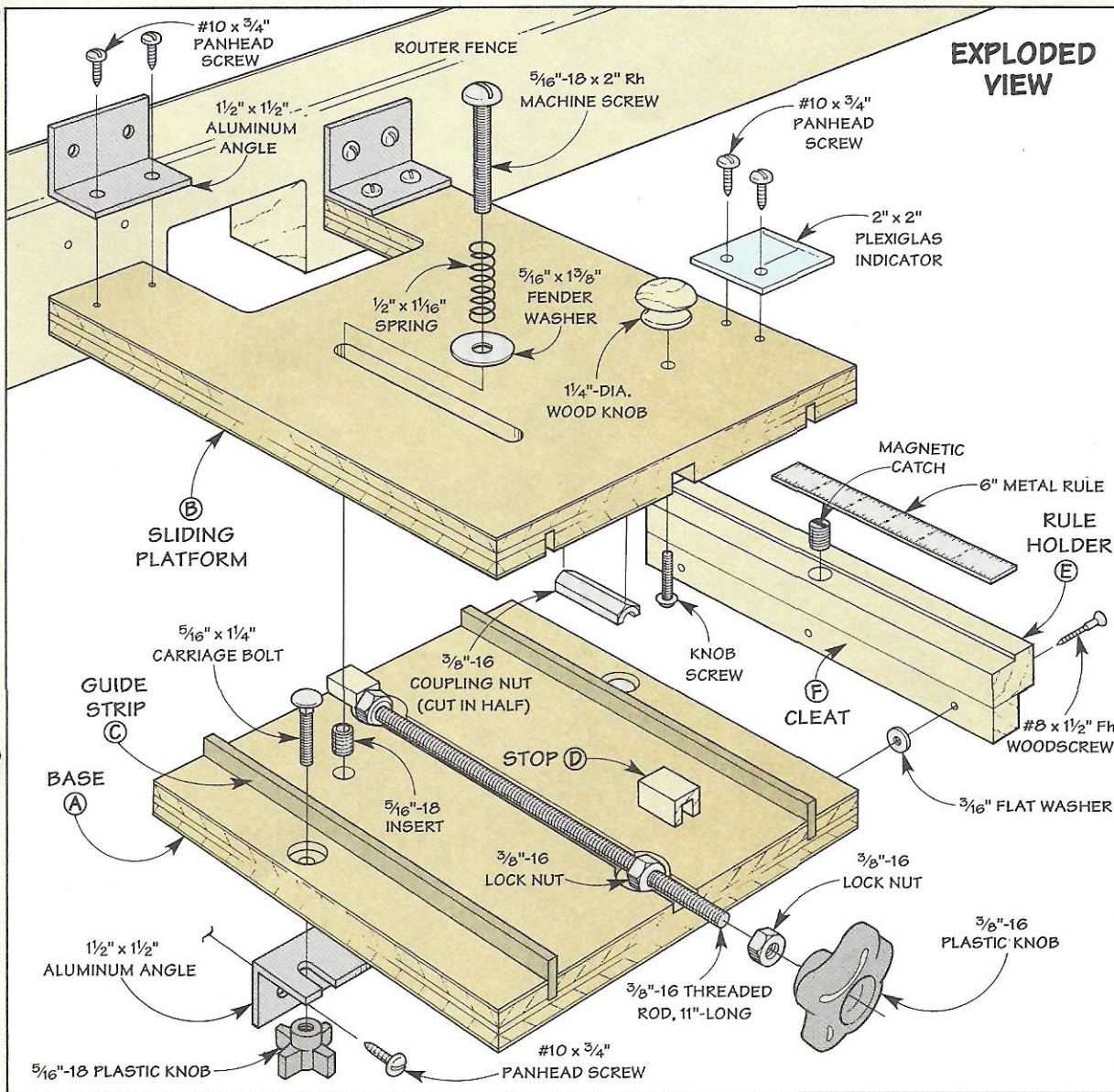

Materials & Hardware

Materials

A Base (1)	10 x 10 - 3/4 plywood
B Sliding Platform (1)	10 x 13 1/2 - 3/4 plywood
C Guide Strips (2)	3/4 x 10 - 1/4 Masonite
D Stops (2)	5/8 x 1/2 - 1
E Rule Holder (1)	3/4 x 1 1/4 - 10
F Cleat (1)	3/4 x 3/4 - 10

Hardware

- (14) #10 x 3/4" Panhead Screws
- (2) 1 1/2" x 1 1/2" - 1/8" Aluminum Angle 2 1/2"-long
- (1) 1 1/2" x 1 1/2" - 1/8" Aluminum Angle 10"-long
- (1) 5/16"-18 x 2" Rh Machine Screw
- (1) 1/2" x 1/16" Compression Spring
- (1) 5/16" x 1 3/8" Fender Washer
- (1) 5/16"-18 Threaded Insert
- (1) 1/4"-dia. Wood Knob
- (1) Knob Screw
- (1) 3/8"-16 Coupling Nut (1 3/4"-long)
- (1) 3/8"-16 x 11" Threaded Rod
- (3) 3/8"-16 Lock Nuts w/Nylon Inserts
- (1) Plastic Knob w/3/8"-16 Through Insert
- (2) 5/16"-18 x 1 1/4" Carriage Bolts
- (2) Plastic Knobs w/5/16"-18 Through Inserts
- (3) #8 x 1 1/2" Fh Woodscrews
- (3) 3/16" Flat Washers
- (1) Round Magnetic Catch
- (1) 2" x 2" - 1/8" Plexiglas

Indexing System

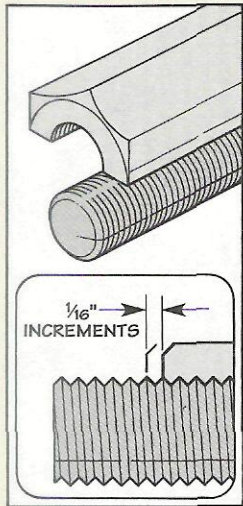

The heart of the indexing jig is a split coupling nut that engages the threads of a rod.

After installing the guide strips, the next step is to add the indexing system. There are two main parts to this: a threaded rod and a split coupling nut. These two parts interlock to create a simple but accurate "rack" that can be moved in precise 1/16" increments, see Drawing at left.

THREADED ROD. The threaded rod sits in the groove you cut earlier in the base (A). A pair of stops (D) and lock nuts will be added later to "capture" this rod, see Fig. 3a. To provide clearance for the lock nuts, shallow "pockets" are drilled near each end of the base, see Fig. 4.

After the pockets are drilled, cut a piece of 3/8"-16 threaded rod to a length of 11". To make it easy to turn the rod by hand, I added a plastic knob (you could also use a wing nut) and a lock nut to one end, refer to Fig. 3.

STOPS. To hold the rod in place, I used a pair of stops (D), see Fig. 5. They're basically small "saddles" that fit over the rod.

Safety Note: To cut the grooves in such small parts, I started with an oversize blank, see Fig. 5.

Begin by resawing or planing the blank to match the width of the groove in the base (5/8"), see Fig. 5. Then cut a 3/8" x 3/8" groove centered on the thickness of the blank, see Fig. 6.

To do this, set your 1/4" dado blade to cut slightly off-center.

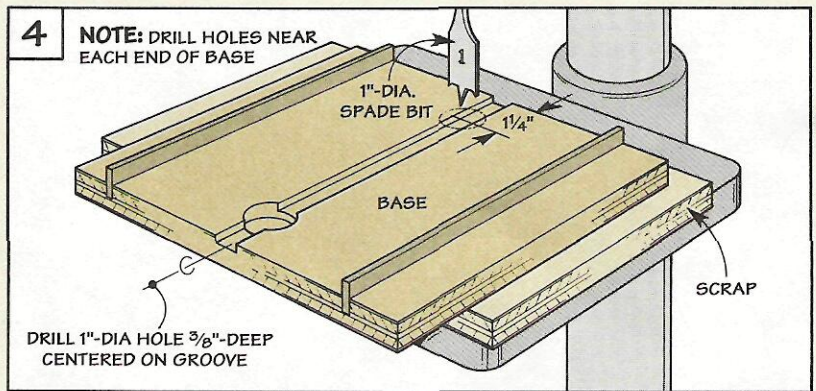
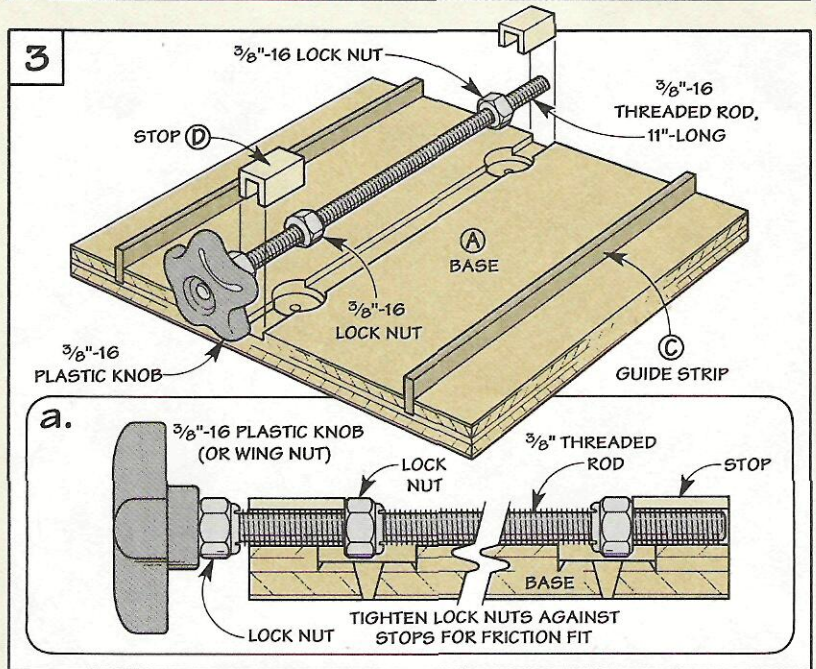

Then make passes flipping the workpiece end for end between cuts. Adjust the fence as needed to produce a 3/8"-wide groove.

Now all that's left is to rip a 1/2"-wide (tall) strip off the blank and cut the two stops (D) to length, refer to Fig. 5.

Finally, slip the stops (D) over the rod and glue them to the base flush with the ends, refer to Fig. 3a. When the glue is dry, adjust the nuts to butt up against the stops. The idea here is to tighten them so they hold the rod in place, yet still allow it to turn freely.

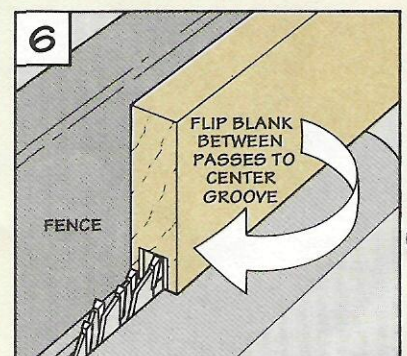
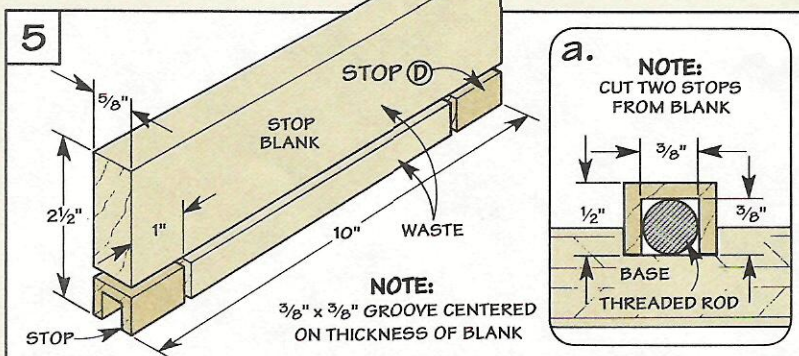

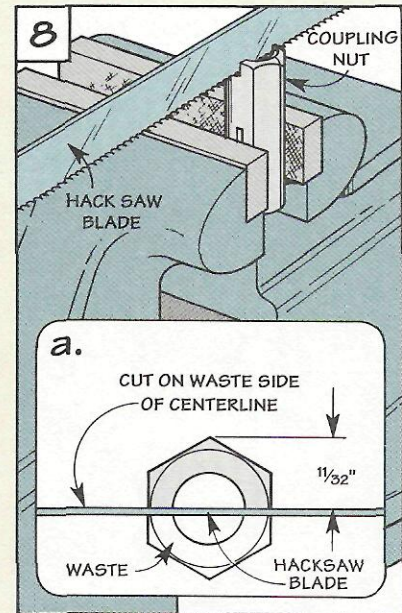
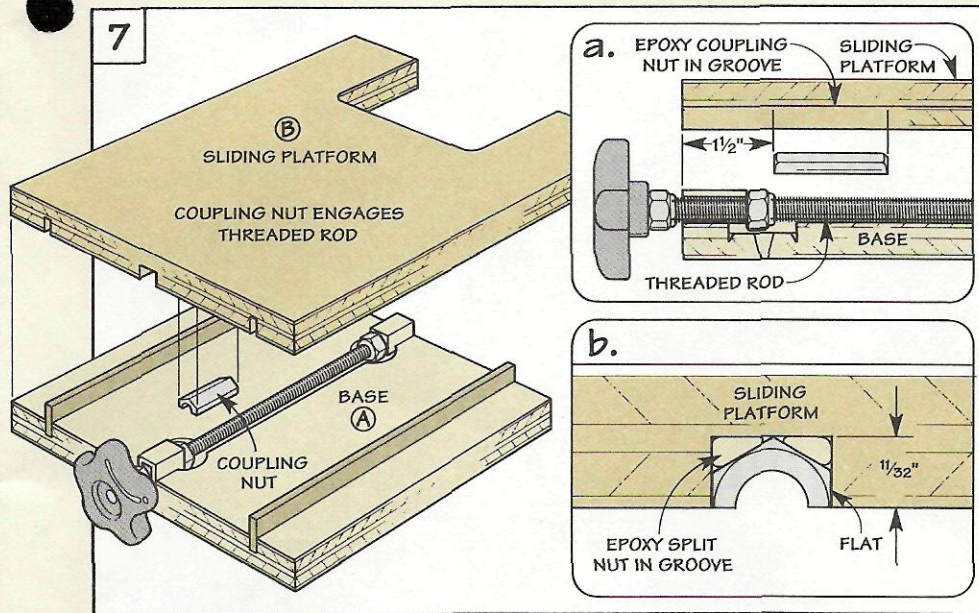

COUPLING NUT. Now you can add the second half of the indexing system — the split coupling nut. It fits in the groove cut in the sliding platform and engages the threads of the rod, see Fig. 7. As the rod is turned, it moves the platform (and the router table fence) back and forth.

To “split” the nut and expose the threads, you’ll need to cut it to one side of the center line, see Figs. 8 and 8a. The idea here is to end up with two “flats” on each side of the nut. These flats press up against the walls of the groove in the sliding platform to lock the nut in the groove, refer to Fig. 7b.

Note: To split the nut without binding on the saw blade, cut half-way through, see Fig. 8. Then flip the nut and finish the cut.

Next, file the rough edges smooth so when the nut sits in the groove, the cut edges are flush with the face of the sliding platform. Then epoxy it in place in the sliding platform, refer to Fig. 7a.

HOLD-DOWN. The indexing system is basically complete at this point. All that’s left is to add a hold-down to “lock” the sliding platform in position, see Fig. 9.

To do this, I used a spring that fits over a screw threaded into

the base, see Figs. 9 and 9a. The spring forces the platform tight against the base and allows you to lift the platform and quickly reposition it for a cut.

CUT SLOT. To allow the platform to slide over a wide range of positions, a slot is cut in it for the screw to pass through, see Fig. 9. This screw then threads into a threaded insert in the base.

To install the insert, position the platform on the base so the ends are flush. Then locate the

hole for the insert on the base. (I inserted a brad point bit in the end of the slot and made a mark.) Now drill a hole to fit the insert and thread it in the base.

Before installing the hold-down hardware, I added a knob to the platform to make it easy to lift it and position the fence, see Fig. 9. Finally, slip on the spring and washer and tighten the screw to “lock” the platform in place. (A complete hardware kit is available, see Sources on page 31.)

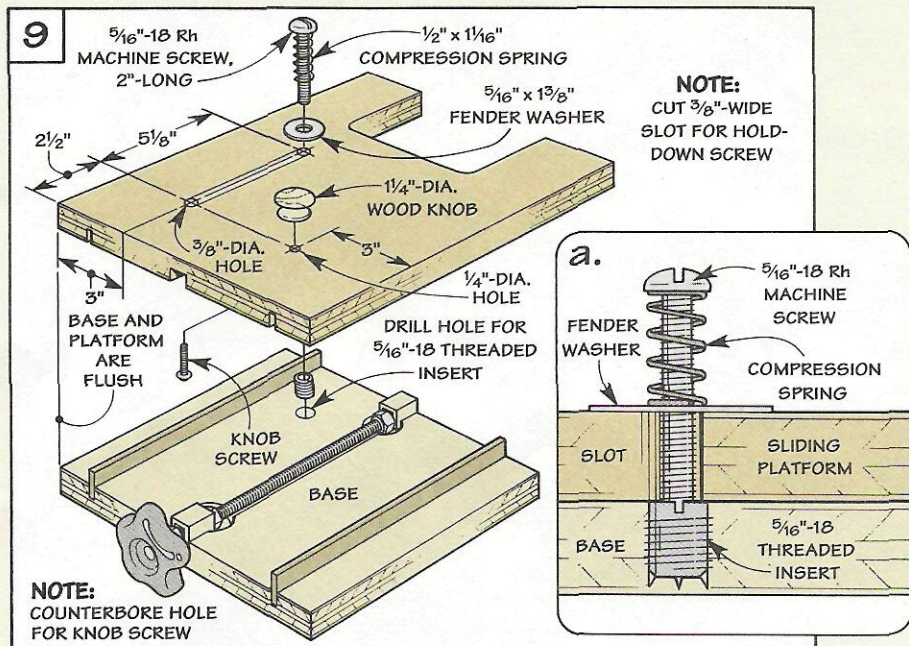

Final Assembly

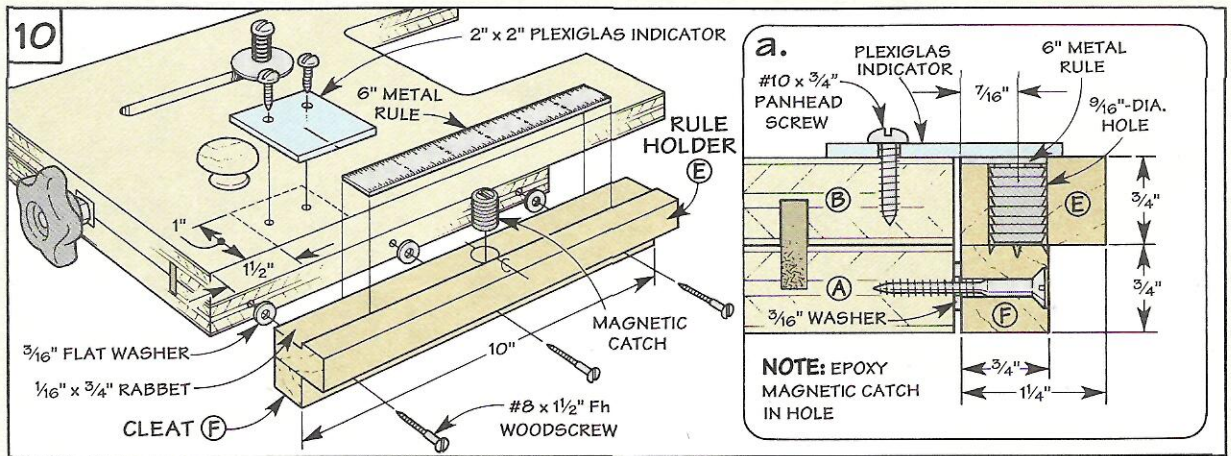

There's one more thing to add to the jig — the positioning gauge.

POSITIONING GAUGE

The positioning gauge lets you see how much you've moved the fence. It consists of a two-piece

rule holder, a metal rule, and a hairline indicator, see Fig. 10.

RULE HOLDER. The top edge of the rule holder (E) is rabbeted to accept a 6" metal rule. A magnetic catch centered on the length of the holder keeps the rule in

position, see Figs. 10 and 10a.

CLEAT. To attach the holder to the base, a cleat (F) is glued to the bottom of the holder, see Fig. 10a. Then, to prevent the platform from binding against the holder, I added washers between the cleat and base, see Fig. 10a.

Finally, I added a Plexiglas indicator to the sliding platform, see Fig. 10 and Drawing in margin. To make it easy to read, I scribed a hairline on the back side.

MOUNTING THE JIG

The indexing jig is fastened to the router table and fence with aluminum angle, see Fig. 11. Two short pieces connect the platform to the fence.

A longer piece is screwed to the back edge of the table and holds the jig in place. Slots allow you to quickly slide the jig off the router table, see Figs. 11 and 11a.

Once these pieces are attached, the next step is to locate holes for the carriage bolts that hold the jig in place. To do this, extend the platform as far as it will go. Then position the front edge of the fence over the hole in your router table, see Fig. 11b.

Now with the jig clamped in place, drill 5/16"-dia. holes up through each slot in the angle. Counterbore these holes and add carriage bolts and plastic knobs (or wing nuts) to secure the jig.

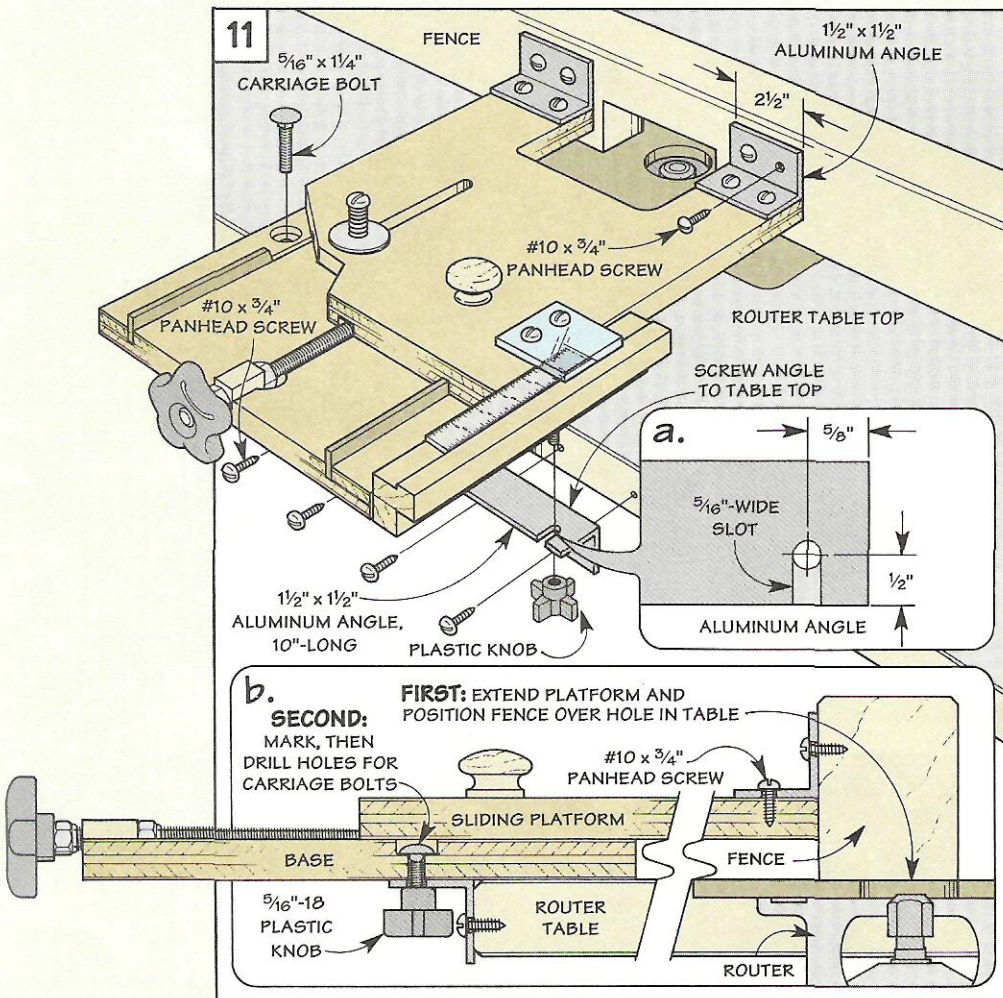

Set-Up

The indexing jig features two basic “modes” of operation. For quick positioning of your fence in precise 1/16” increments, just lift up the sliding platform, move it to the desired location and set it down to make the cut, see photo top right.

Or you can fine-tune the fence by “sneaking up” on a cut. All it takes is a twist of the micro-adjust knob, see photo bottom right.

Regardless of the mode or router bit you’re using, the first step to using the jig is to find the starting point. This is simply a matter of “zeroing” the fence on the bit, see the box below. Then sliding the rule in the holder so the “0” is directly under the hairline indicator. Now simply lift the platform or turn the knob to set the fence to the desired cut.

Safety Note: Although the hold-down on the indexing jig “locks” the sliding platform in place, you should always use your fence clamping system to prevent the fence from shifting once it’s adjusted.

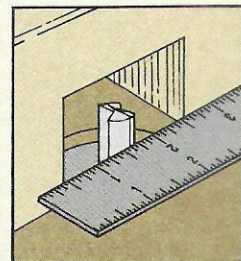
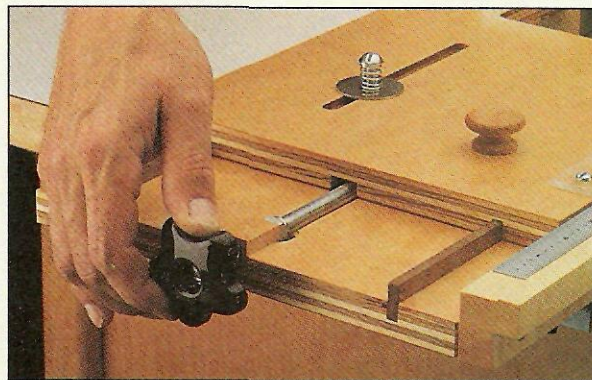
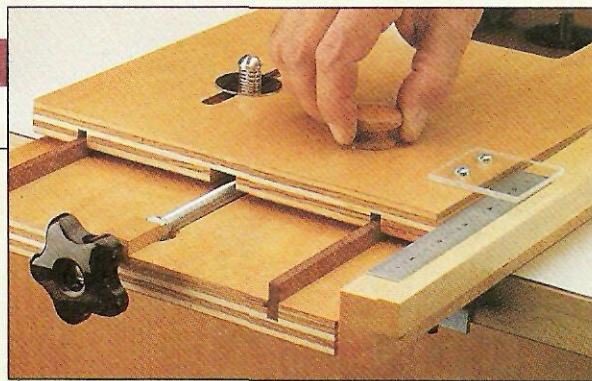

A straightedge makes it easy to set your router bit flush with the fence.

Using the Jig

Setting up the indexing jig for a cut is a two step process: zeroing the fence, then adjusting it for the desired cut.

ZERO THE FENCE. To “zero” the fence, first loosen the clamps that hold the fence to the table. Then lift the platform and slide the fence flush

with the cutting edge of the bit, see Fig. 1. (If needed, use the micro-adjust knob to adjust the fence so it’s perfectly flush.)

The next step is to “zero” the rule. Just slide it under the indicator so one end is directly beneath the hairline.

SET THE FENCE. Now to set the fence for the desired cut, just lift the sliding platform and set it where you want it, see Fig. 2. The indicator shows you how far you’ve moved the fence. And if you want to “sneak up” on a cut, use the micro-adjust knob.

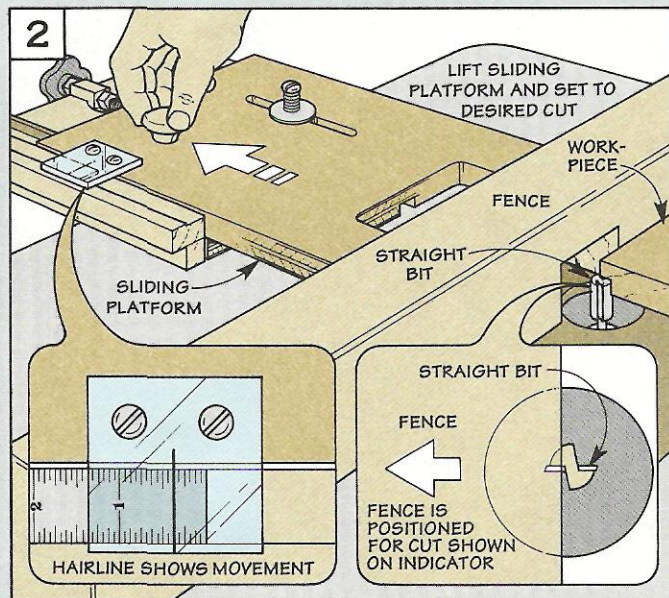
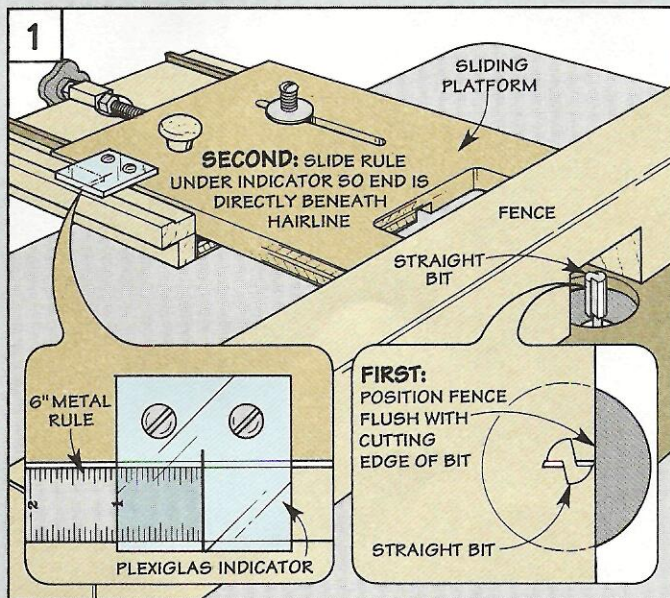

Zero the Fence: Start by lifting the sliding platform and positioning the fence flush with the bit. Then slide the rule under the indicator so the “zero” end is under the hairline.

Set the Fence: After setting the ruler to “zero,” lift the platform and slide the fence into position. The indicator shows exactly how much you’ve moved the fence.

Drill Bit Case

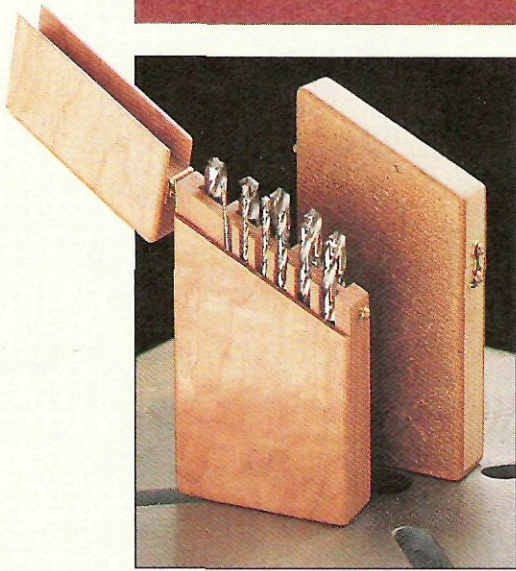

A few scrap pieces of wood and Masonite are all it takes to make a pocket-size case for your drill bits.

I took some ribbing from the guys in the shop while I was making this drill bit case. After all, why make a case when you can go down to the hardware store and buy one? One reason is that even though both do a good job organizing bits, this case gave me a perfect opportunity to use up some of the small scrap pieces I had laying around.

In fact, after I finished the case, I noticed a lot more digging around the scrap bin than usual. About the same time, the kidding quieted down considerably, and drill bit cases started popping up like mushrooms in the shop.

MATERIALS. To build the case, I used scrap pieces of maple and Masonite. But you could make it entirely out of hardwood like the cherry case in the photo at left.

TWIST BITS. The drill bit case is designed to hold eleven twist bits ranging in size from $\frac{1}{16}$ " to $\frac{3}{8}$ " in $\frac{1}{32}$ " increments. To provide room for that many bits in a pocket-size case, I started with a $2\frac{7}{8}$ "-wide blank, see Fig. 1.

CORE PIECES. Since these bits "stairstep" up as the diameter increases, I cut the blank at an angle to match the line formed by the tips of the bits. This produces two core pieces — one for a tray to hold the bits, and the other for a lid, see Fig. 1. Note: Each core piece is cut *extra* long.

TRAY. Now work can begin on the tray (A). To create a "pocket" for each bit, I cut

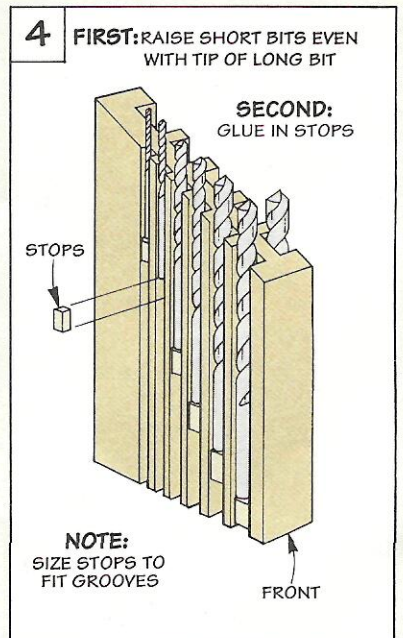
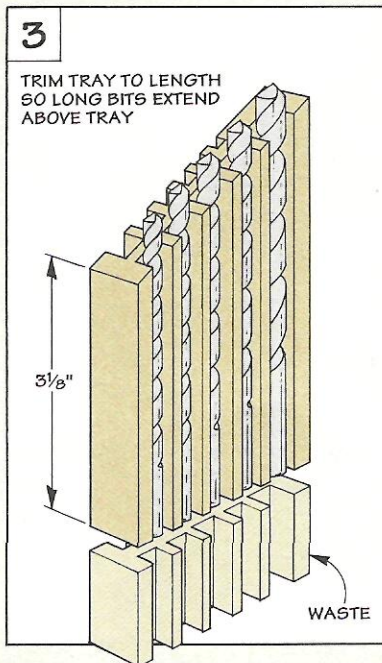
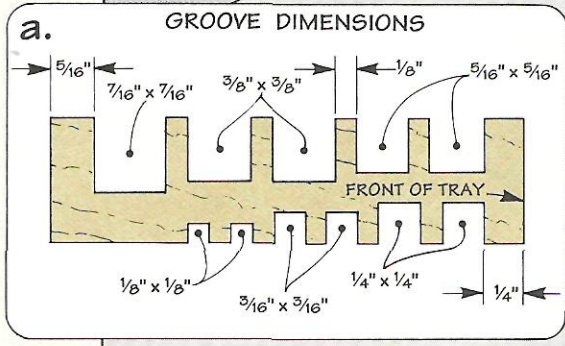
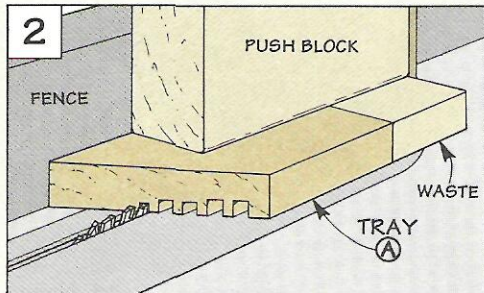
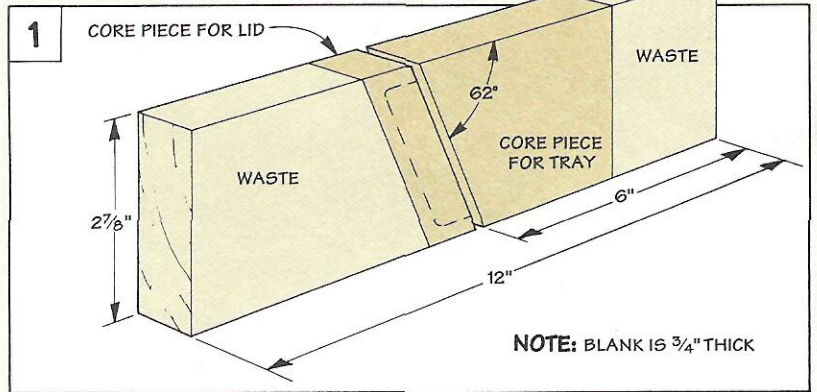

a series of grooves in the tray *slightly* deeper and wider than the diameter of the bits, see Figs. 2 and 2a. Then I trimmed the tray to its finished length, see Fig. 3.

STOPS. To keep the *short* bits from dropping to the bottom of the tray, I added six "stops." These are just short pieces of wood that are glued into the grooves under the end of each bit, see Fig. 4.

The idea is to locate the stops so all the bits stick up the same amount. By placing the end of one of the longer bits flush with the bottom of the tray, you can use the tip as a gauge to raise the short bits to the correct height, see Fig. 4.

LID CORE. After installing the stops, work can begin on the core piece for the lid (B). To provide clearance for the bits when the lid is closed, a recess is cut in the bottom (angled) end, see Fig. 5.

WRAP CASE. The next step is to fit the lid to the tray. To do this, the case is "wrapped" with 1/8"-thick Masonite. Note: You can

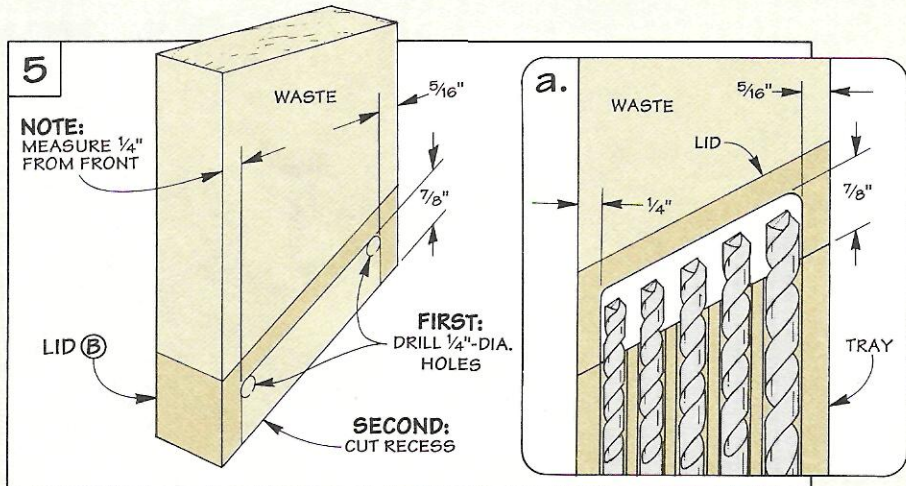

also use thin strips of hardwood.

The bottom (C) is cut to fit and glued on first, see Fig. 6. Then the sides are added. I started with a long blank for each side of the case and cut the side pieces at an angle to match the core pieces.

ATTACH SIDES. Attaching the sides is easy. They're just glued in place. The trick is locating them so the lid fits down snug over the tray like the top on a shoebox.

To do this, a narrow shoulder is formed by attaching the *tray*

sides (D) 3/8" below the top of the tray, see Fig. 6. The lid sides (E) extend the same amount *below* the lid. This creates a lip that allows the lid sides to "seat" over the end of the tray.

FINAL DETAILS. To complete the case, the top of the lid is trimmed to match the angle of the side pieces, see Fig. 6. Then, after softening the sharp edges, I installed a hinge and a small hook, see Figs. 7 and 8. (For mail order sources, see page 31.)

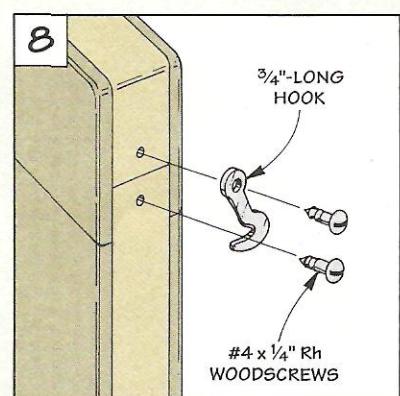
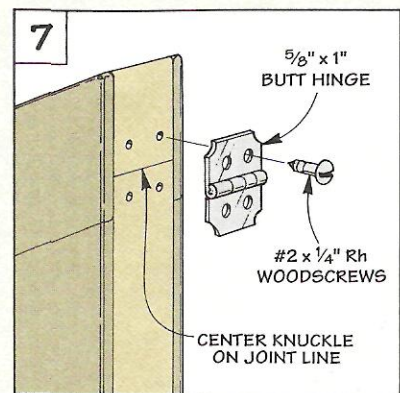
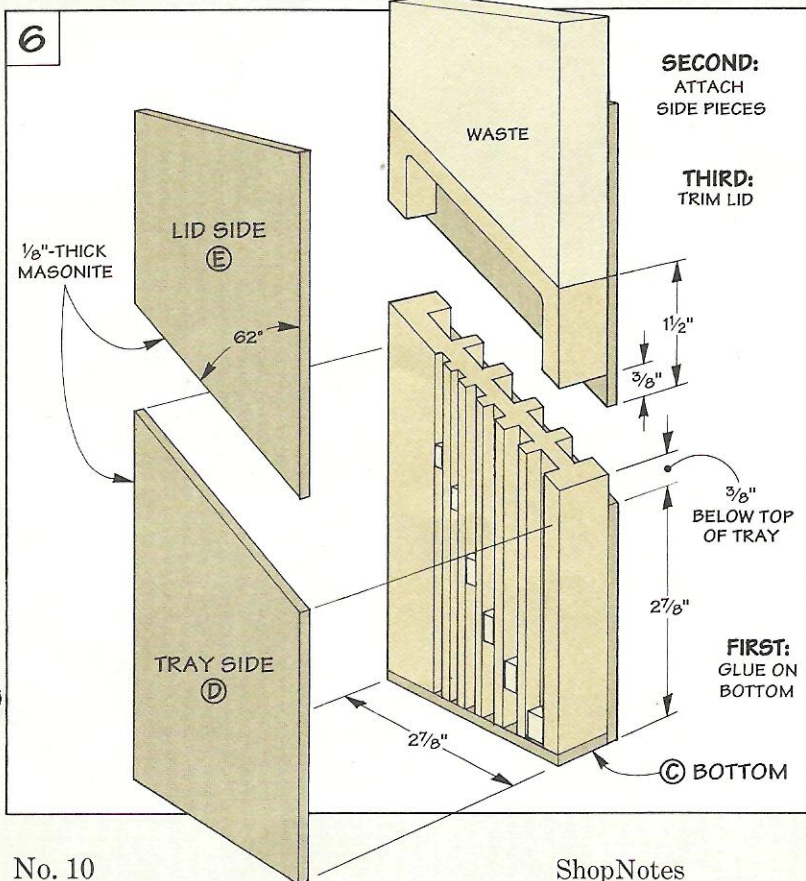

- Hardware**
- (4) #2 x 1/4" Rh Screws (Brass)
 - (1) 5/8" x 1" Butt Hinge (Brass)
 - (2) #4 x 1/4" Rh Screws (Brass)
 - (1) 3/4"-Long Hook (Brass)

Perfect Miters

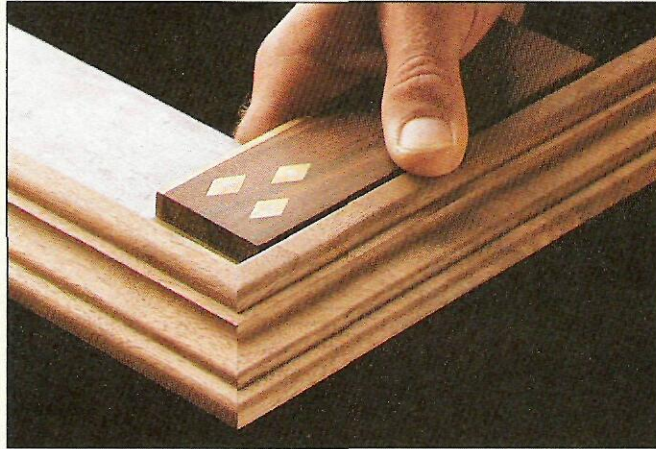

Tips and techniques for cutting perfect miter joints.

If there's one thing that can try the patience of most woodworkers, it's cutting a perfect miter joint on the table saw.

It seems that no matter how carefully the miter gauge is adjusted to get a "perfect" fit, you can still be off just a hair. What's frustrating is you don't even realize it until you've mitered all the pieces, fit them together, and end up with a gap at one of the joints.

Fortunately, there are several things you can do to ensure tight-

fitting miter joints. A few preliminary "tune-ups" before you make your first cut will keep problems from cropping up later.

BLADE. One thing that's often overlooked is the saw blade. To avoid a ragged joint line, it should be sharp. In addition, I always make it a point to check that the blade is square to the saw table, see the box below.

AUXILIARY FENCE. But probably the simplest (and most effective) thing you can do to improve

the accuracy of your miters is to screw an auxiliary fence to the miter gauge, see Fig. 1. There are a couple of reasons for this.

SUPPORT. Since the fence provides more support along the edge of a workpiece than the miter gauge, you can hold the work more securely as a cut is made. Note: I also attach sandpaper to the fence to prevent the workpiece from "creeping," see Fig. 1.

REDUCES CHIPOUT. A second advantage of the fence is it re-

Squaring a Saw Blade

Before cutting a miter joint, I always take a few minutes to square the saw blade to the table.

TRY SQUARE. To get as accurate a reading as possible, I use a try square, see Detail a. Just be sure the blade of the square is tight against the face of the saw blade (not a tooth).

TEST CUT. Even after squaring the blade, it's a good idea to double check it. A quick way to do this is to make a test cut on the end of a scrap piece of wood, see Drawing. Then flip the cut-off piece over and butt the two ends together. If there's a gap where the two ends meet, the blade isn't square and needs to be readjusted, see Detail b.

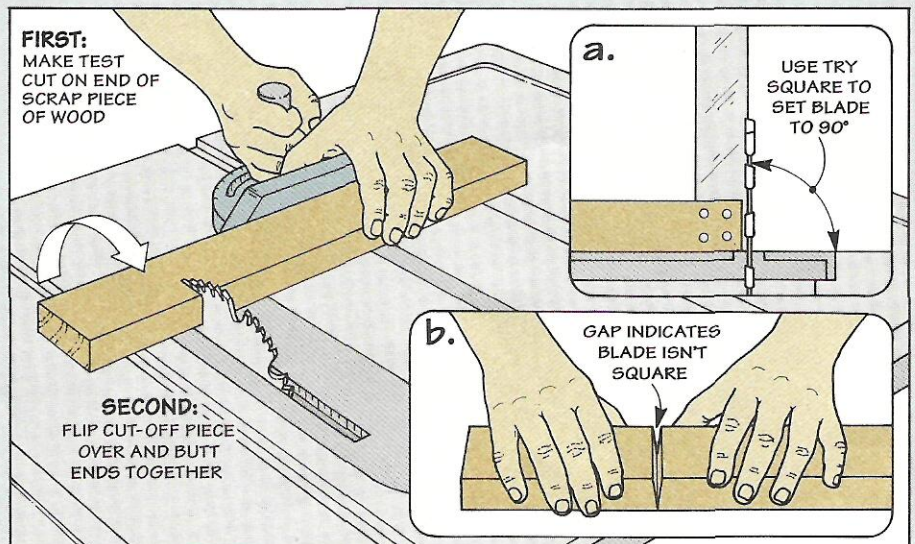

duces chipout by backing up the edge of the workpiece as the blade cuts through. Just make sure it's long enough to support the work and the waste piece, see Fig. 1. And tall enough so the blade doesn't cut all the way through.

Although the fence solves the problem of chipout on the back edge, it doesn't prevent wood fibers on the face from "lifting." To solve this, you need to consider the direction the miter gauge is angled.

ANGLE. To produce a crisp cut, I angle the gauge so the blade exits the long tip of the miter, see Fig. 2. This way the blade cuts with the grain. When the gauge is angled in the opposite direction, the blade cuts against the grain and causes tearout, see Fig. 3. Also, the waste piece can pinch against the fence and get thrown back.

GETTING A PERFECT FIT

So how do you go about getting a tight-fitting joint? One way would be to set the miter gauge once to 45° and then cut all four miters. But this presents a couple of problems.

First, you'd need to flip a workpiece end for end and turn it over between cuts. This not only prevents having one "good" side. But a molded piece "rocks" on the saw table when it's placed face down.

A second problem is if the miter gauge isn't "dead-on" accurate,

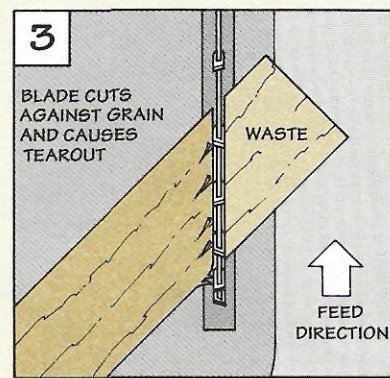
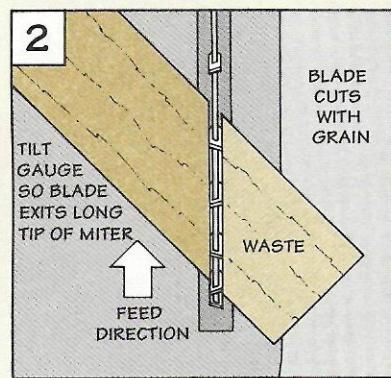
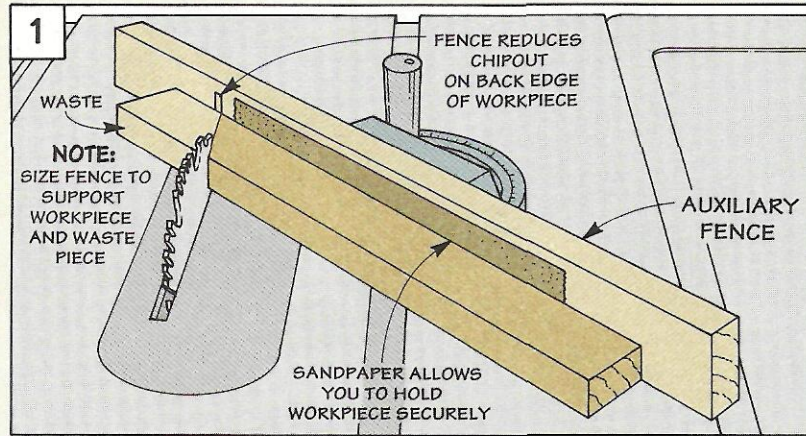

you end up with a corner that's not 90°. Trying to square up the corner creates a gap at the joint.

OVERALL ANGLE. So instead of trying to get a perfect 45° miter, I use a different approach. The idea is to get the mitered pieces to form an overall angle of 90°, see Fig. 4.

To do this, I use the head of a combination square to set the mi-

ter gauge to 45°, see Fig. 4a. Then, after cutting the first miter, I move the gauge to the other side of the blade and angle the head in the opposite direction.

The secret is to make all the adjustments to the miter gauge at this second (complementary) setting. This way, if the first miter is off, the second one can be cut to compensate for the error.

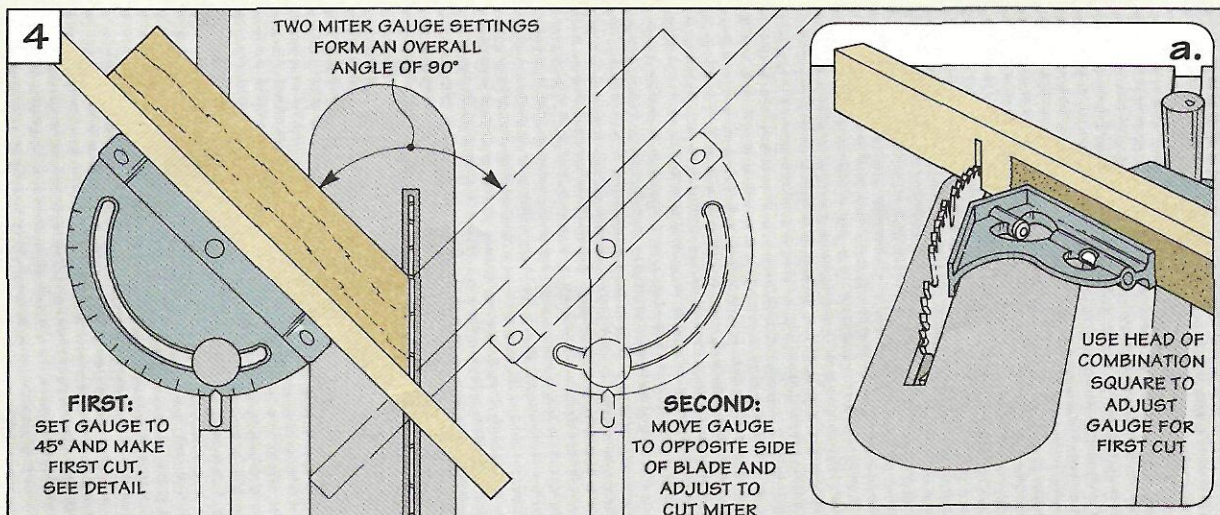

Cutting the Miters

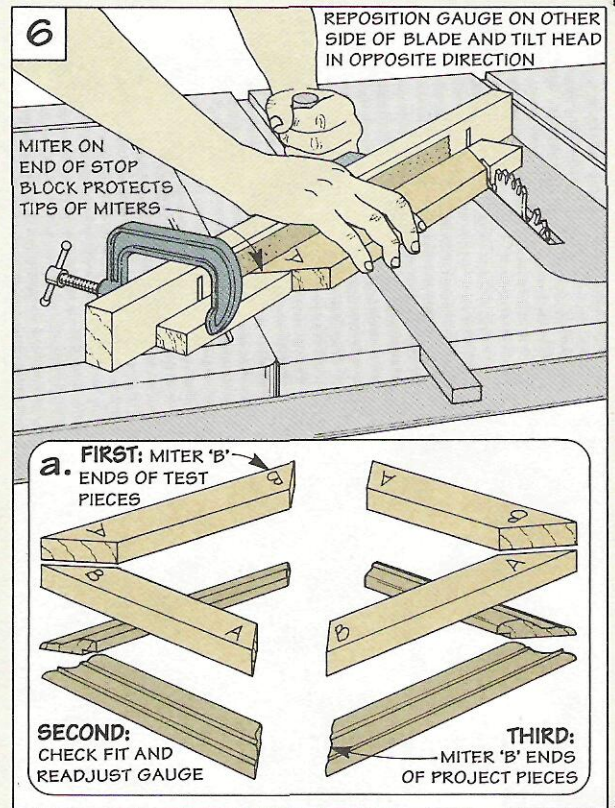
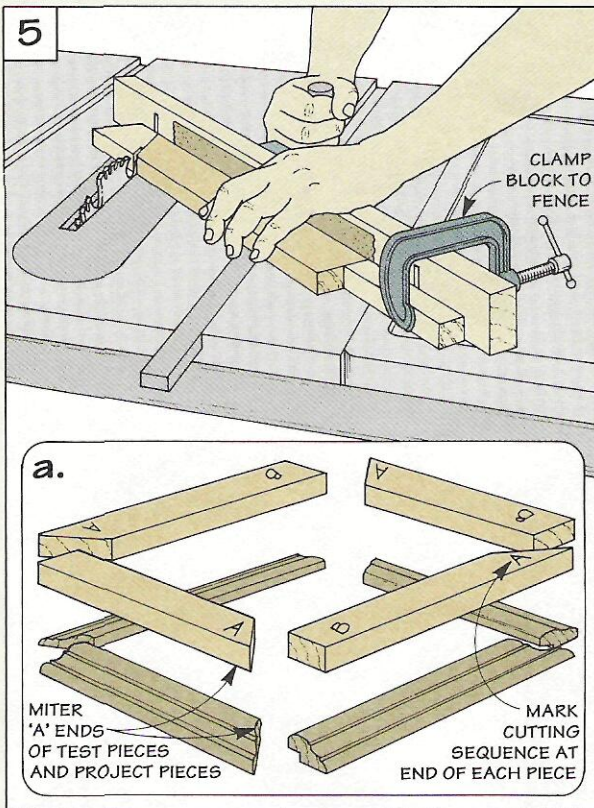

Cutting a perfect miter joint on a single corner is one thing. The trick is getting all *four* corners (on a frame for example) to fit tightly together. To do this, I make two frames: a test frame, and the “real” frame.

The test frame is just four scrap pieces of wood used to adjust the fit of the miters. This way, any problems are ironed out *before* cutting the project pieces. The key is to miter the pieces in the proper sequence.

SEQUENCE. To keep things organized, I lay out all the pieces in their “finished” position and mark the cutting sequence on the ends of the test pieces, see Fig. 5a. Then, with the miter gauge set to 45°, the ‘A’ ends of the test pieces and the matching ends of the project pieces are cut.

Note: To provide insurance against the work creeping, I clamp a block to the fence, see Fig. 5.

MOVE GAUGE. After cutting all the miters on one end, you’ll need

to position the miter gauge on the other side of the blade and angle the head to the opposite 45° setting. It’s okay just to get close, at least for now.

That’s because the idea is to sneak up on the perfect fit by mitering the ‘B’ ends of *all* the test pieces, see Fig. 6a. If there’s a gap when you fit these pieces together, just readjust the gauge and trim the miters again, see Fig. 7.

Note: If the gap is so small that

any adjustment only exaggerates the error, see the tip at left.

COMPLETE MITERS. Finally, once you’re satisfied with the way the test frame fits together, you can miter the opposite ends of the *project* pieces. Since these miters duplicate the test miters, they’re bound to fit tight together.

Note: To protect the tips of the miters, I use a stop block with a mitered end to cut the pieces to exact length, refer to Fig. 6.

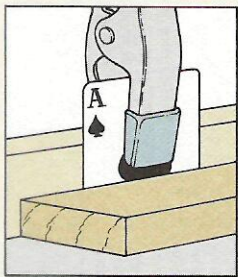

To “micro-adjust” the angle of the miter, use a playing card as a shim.

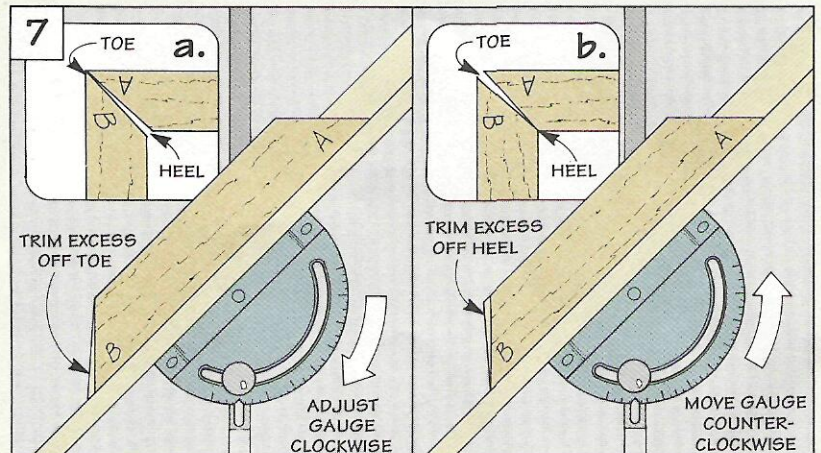

Miter Jig

If you're doing a lot of mitering, it might be worthwhile to build a special jig. Although this jig is used in place of the miter gauge, the basic idea is the same — cutting two complementary miters.

FENCE. The key is a two-part fence that corresponds to the two settings of the miter gauge. Together, the two parts of the fence form a 90° angle, see Step 3 below. As a result, the overall angle

of the miters will also be 90°.

Besides the angle, there's one other thing to consider. If you cut your workpieces to rough length before mitering them, the ends will extend past the blade.

To keep the ends from hitting the opposite fence, the two parts are offset, see photo. Note: This offset determines the *widest* workpiece you can miter with the jig. (In my case, this is 3".)

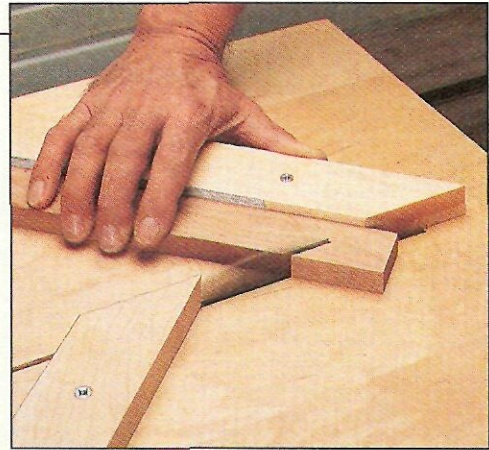

Step 1: Build the Base.

The base consists of a 3/4"-thick piece of plywood and a pair of hardwood runners that slide in the miter gauge slots in the table saw. After cutting the plywood to length to fit the table, it's centered over the blade to mark the location of the slots on the edges of the plywood. These marks are used to position the runners before screwing them in place.

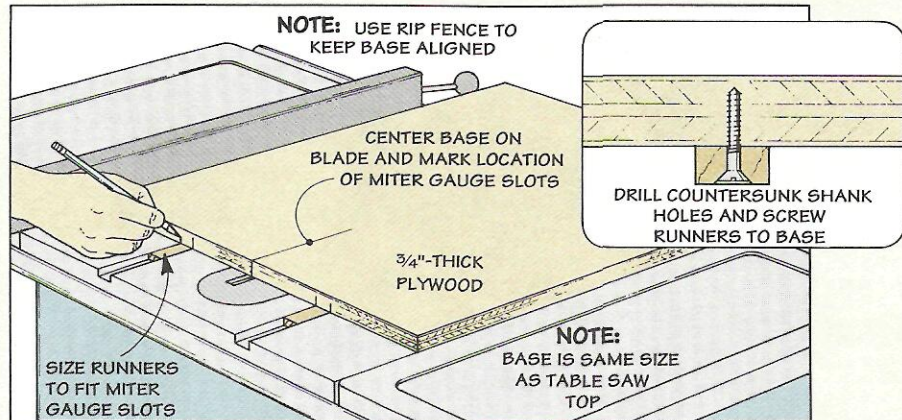

Step 2: Cut Kerf in Base.

The jig is designed to carry a workpiece through the blade by pushing the base across the saw table. This requires cutting a kerf in the base for blade clearance. To prevent the two halves of the base from flapping up and down, a cleat is glued at the front edge before cutting the kerf. The back edge is kept rigid by not pushing the base all the way through the blade.

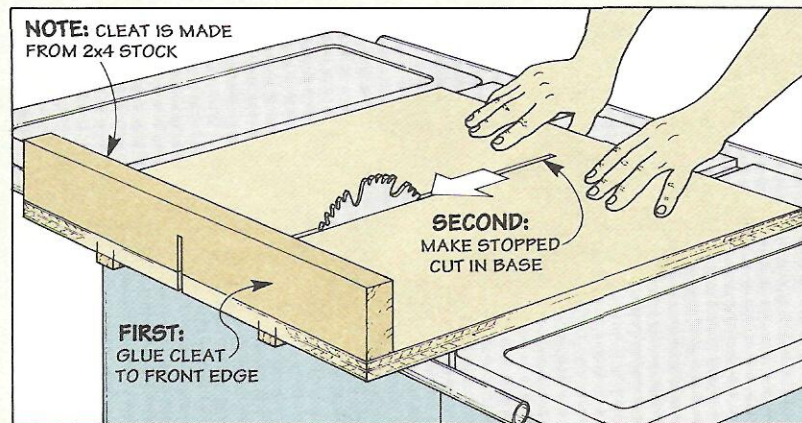

Step 3: Attach Fence.

To ensure the miters form a perfect 90° angle, the two parts of the fence are positioned using a framing square. By offsetting the fence, you can extend pieces that are cut to rough length past the blade. After screwing the fence to the base, it's just a matter of pushing the jig through the blade to trim off the ends.

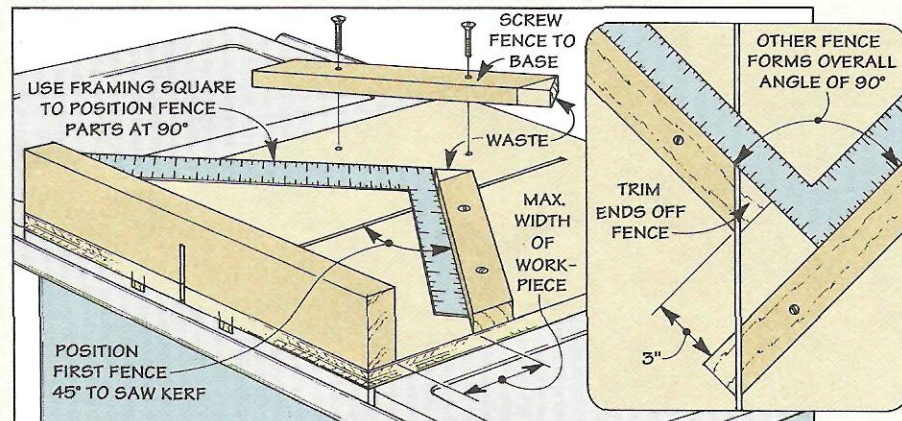

Lathe Stand

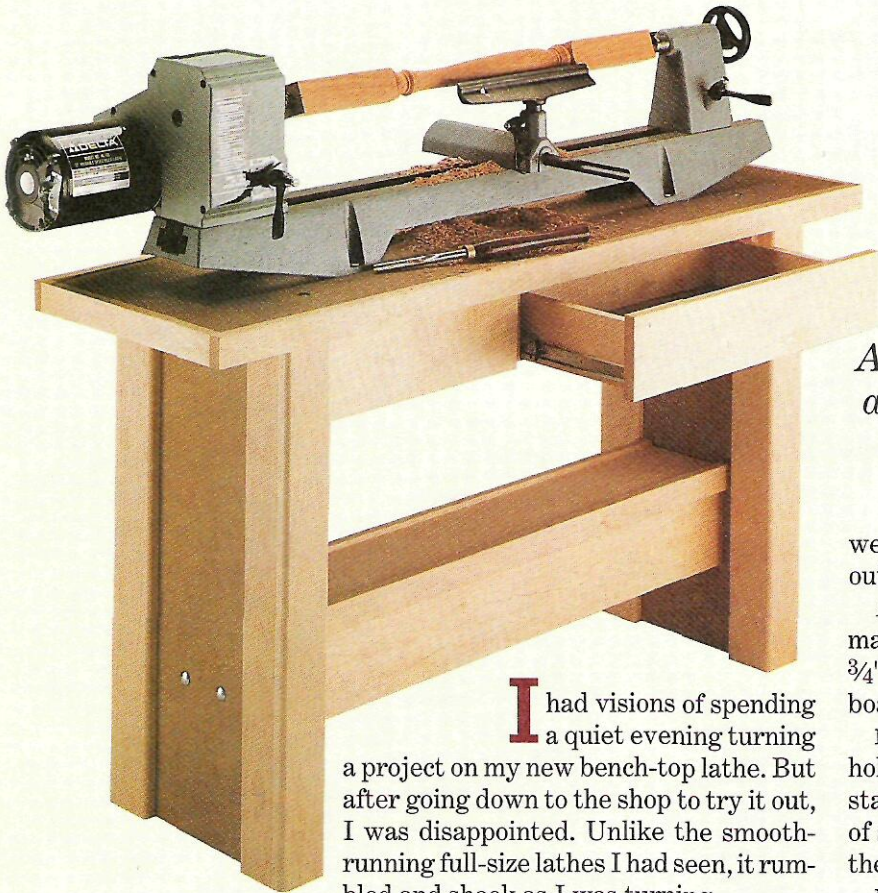

A heavy top supported by solid legs and a "sand box" absorb the vibration set up by a bench-top lathe.

I had visions of spending a quiet evening turning a project on my new bench-top lathe. But after going down to the shop to try it out, I was disappointed. Unlike the smooth-running full-size lathes I had seen, it rumbled and shook as I was turning.

Fortunately, the problem wasn't the lathe at all — it was the *stand* the lathe was mounted on. Even though the stand was fairly rigid, it was still too lightweight to dampen the vibration set up by the spinning workpiece.

SPONGE. To improve the performance of the lathe, I decided to build a *heavy* stand — one that would work like a big sponge to absorb the vibration set up by the lathe. The trick was to add enough

weight to keep the lathe from rattling around without making the stand look like a wood boxcar.

After looking around for the heaviest, densest material I could find, I found just what I needed — $\frac{3}{4}$ "-thick particleboard. Two layers of this particleboard are built *into* the legs and the top of the stand.

BEAM. To add even more weight, there's also a hollow "beam" that spans between the legs of the stand. This beam can be filled with almost 60 pounds of sand to create additional "ballast" that dampens the vibration of the lathe, see photo below.

KNOCKS DOWN. But all this weight can be a mixed blessing when it comes time to move the lathe stand. To keep it from becoming a "permanent" fixture in the shop, the stand is bolted together so it can be easily knocked down.

OTHER FEATURES. While I was at it, I added a pair of drawers to store my lathe accessories. There's also a unique pivoting tool rack that positions your lathe tools within easy reach when you're turning. (For more on this tool rack, see page 21.)

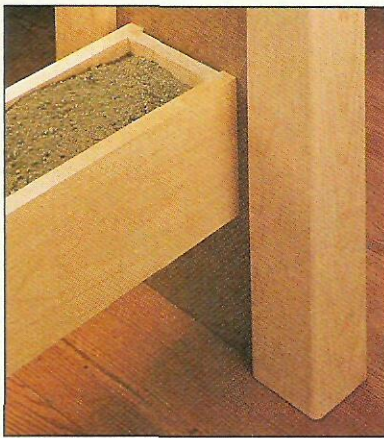

To add stability, a hollow wood beam is filled with sand. This anchors the stand and dampens the vibration of the lathe.

Cutting Diagram

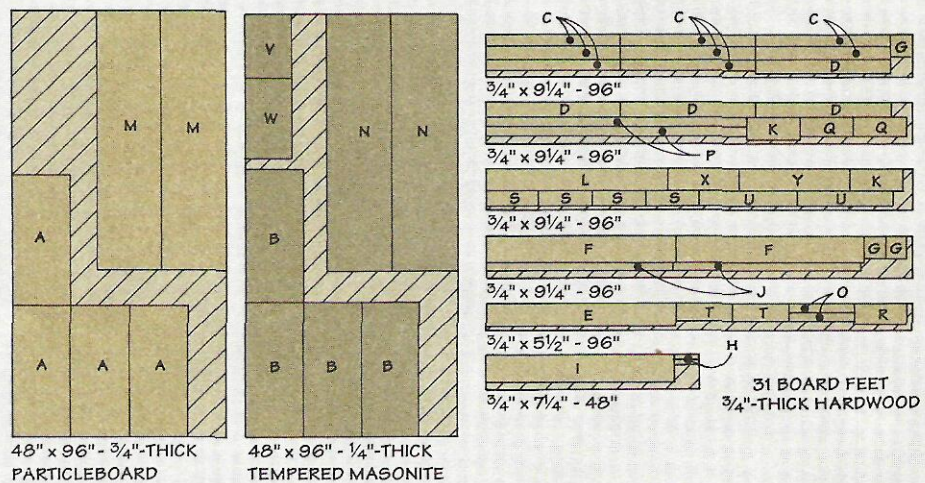

FEATURE PROJECT

EXPLODED VIEW

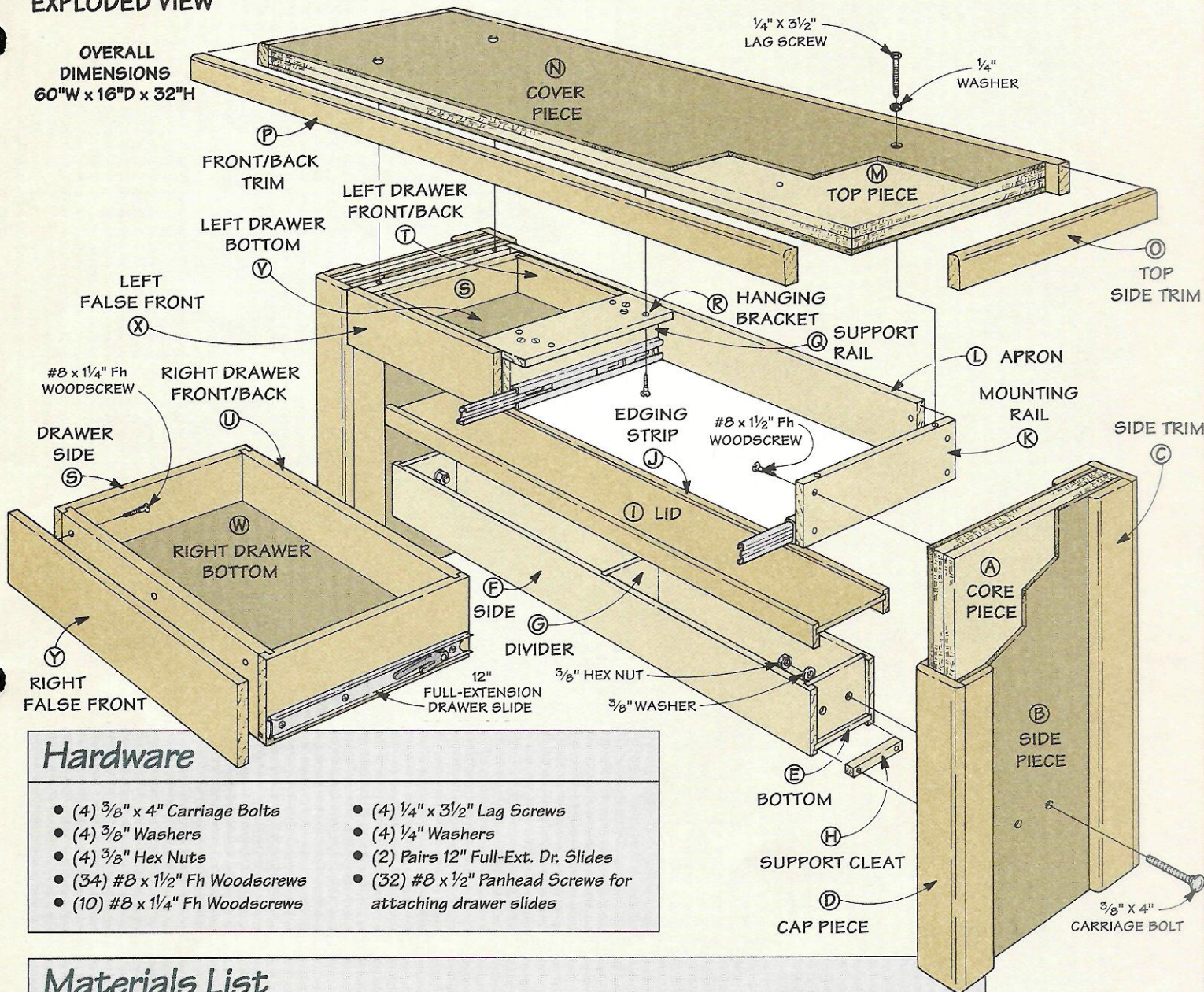

Hardware

- (4) $\frac{3}{8}$ " x 4" Carriage Bolts
- (4) $\frac{3}{8}$ " Washers
- (4) $\frac{3}{8}$ " Hex Nuts
- (34) #8 x $\frac{1}{2}$ " Fh Woodscrews
- (10) #8 x $\frac{1}{4}$ " Fh Woodscrews
- (4) $\frac{1}{4}$ " x $3\frac{1}{2}$ " Lag Screws
- (4) $\frac{1}{4}$ " Washers
- (2) Pairs 12" Full-Ext. Dr. Slides
- (32) #8 x $\frac{1}{2}$ " Panhead Screws for attaching drawer slides

Materials List

Legs

- | | |
|-------------------|---------------------------------------|
| A Core Pieces (4) | 13 x 30 - $\frac{3}{4}$ Particleboard |
| B Side Pieces (4) | 13 x 30 - $\frac{1}{4}$ Masonite |
| C Side Trim (8) | $\frac{3}{4}$ x $2\frac{3}{4}$ - 30 |
| D Cap Pieces (4) | $\frac{3}{4}$ x $3\frac{1}{2}$ - 30 |

Beam

- | | |
|----------------------|--|
| E Bottom (1) | $\frac{3}{4}$ x $5\frac{1}{4}$ - $42\frac{1}{2}$ |
| F Sides (2) | $\frac{3}{4}$ x 6 - $42\frac{1}{2}$ |
| G Dividers (3) | $\frac{3}{4}$ x $5\frac{1}{4}$ - $4\frac{1}{2}$ |
| H Support Cleats (2) | $\frac{3}{4}$ x $\frac{3}{4}$ - $4\frac{1}{2}$ |
| I Lid (1) | $\frac{3}{4}$ x $6\frac{13}{16}$ - $42\frac{1}{4}$ |
| J Edging Strips (2) | $\frac{3}{4}$ x $1\frac{3}{4}$ - $42\frac{1}{4}$ |
| K Mounting Rails (2) | $\frac{3}{4}$ x 5 - 12 |
| L Apron (1) | $\frac{3}{4}$ x 5 - 41 |

Top

- | | |
|-----------------------|---|
| M Top Pieces (2) | $14\frac{1}{2}$ x $58\frac{1}{2}$ - $\frac{3}{4}$ Particlebd. |
| N Cover Pieces (2) | $14\frac{1}{2}$ x $58\frac{1}{2}$ - $\frac{1}{4}$ Masonite |
| O Top Side Trim (2) | $\frac{3}{4}$ x 2 - $14\frac{1}{2}$ |
| P Front/Back Trim (2) | $\frac{3}{4}$ x 2 - 60 |

Drawers

- | | |
|----------------------------|--|
| Q Support Rail (1) | $\frac{3}{4}$ x $4\frac{1}{4}$ - 12 (two pieces) |
| R Hanging Bracket (1) | $\frac{3}{4}$ x $4\frac{1}{2}$ - 12 |
| S Drawer Sides (4) | $\frac{3}{4}$ x 4 - 12 |
| T Left Drawer Fr./Bk. (2) | $\frac{3}{4}$ x 4 - $12\frac{3}{4}$ |
| U Right Drawer Fr./Bk. (2) | $\frac{3}{4}$ x 4 - $21\frac{3}{4}$ |
| V Left Drawer Bottom (1) | $11\frac{1}{4}$ x $12\frac{3}{4}$ - $\frac{1}{4}$ Masonite |
| W Rt. Drawer Bottom (1) | $11\frac{1}{4}$ x $21\frac{3}{4}$ - $\frac{1}{4}$ Masonite |
| X Left False Front (1) | $\frac{3}{4}$ x $4\frac{7}{8}$ - $15\frac{13}{16}$ |
| Y Right False Front (1) | $\frac{3}{4}$ x $4\frac{7}{8}$ - $24\frac{13}{16}$ |

The Legs

I started work by building the legs. The unusual thing about the legs is they're not your ordinary square posts. Instead, they're solid "slabs" that are designed to dampen the vibration set up by the lathe.

SLAB. To make the slabs as heavy as possible, they're built up from two *core pieces* (A) of $\frac{3}{4}$ "-thick particleboard, see Fig. 1. Then they're covered with two $\frac{1}{4}$ "-thick Masonite *side pieces* (B).

Note: The height (length) of the legs determines the finished height of the stand. To position the center of a workpiece about even with my elbow, I made the legs 30" long (high).

CONTACT CEMENT. When gluing up the slabs, I used contact cement to create an "instant" bond. The problem is getting the edges aligned. To do this, I cut one core piece to exact size. Then I built up each layer by attaching an oversized piece and trimming the edges flush, see tip at left.

TRIM PIECES. To cover the front and back edges of the legs, I added $\frac{3}{4}$ "-thick hardwood (maple) trim pieces. After rounding

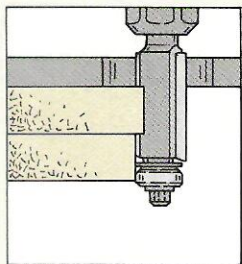

To trim the edges flush, I used a flush trim bit in a hand-held router.

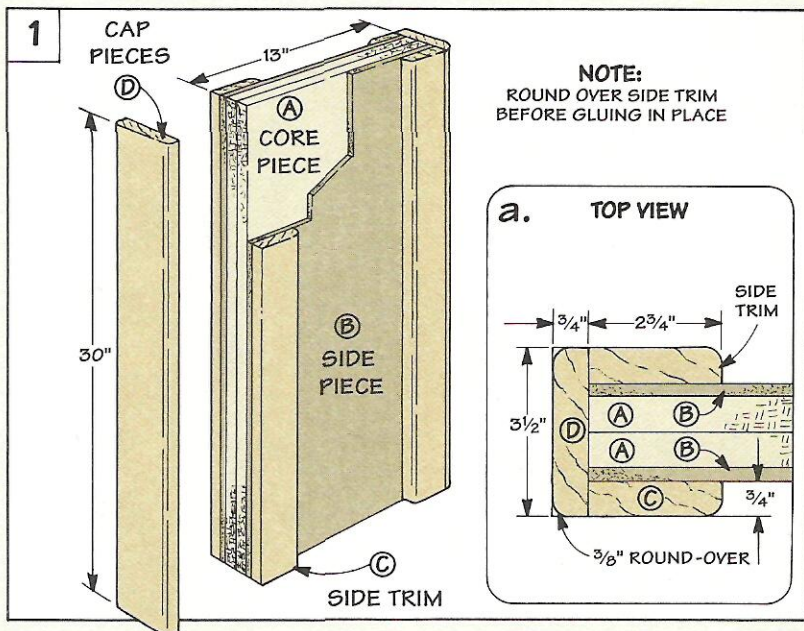

one edge of each *side trim* (C) piece, they're glued in place, see Fig. 1a. Then, to cover the edges of the side trim, the *cap pieces* (D) are glued on, and the outside edges are rounded over.

BEAM

Once the trim is installed, the next step is to build the beam. This is just a box that connects

the legs and can be filled with sand to help absorb vibration.

It consists of a hardwood *bottom* (E) that fits in grooves cut in the *sides* (F), see Fig. 2. The sides are held together with *dividers* (G) that are screwed to the bottom and glued into dadoses cut in the sides, see Figs. 2a and 2b.

ATTACH BEAM. After assembling the beam, you're ready to

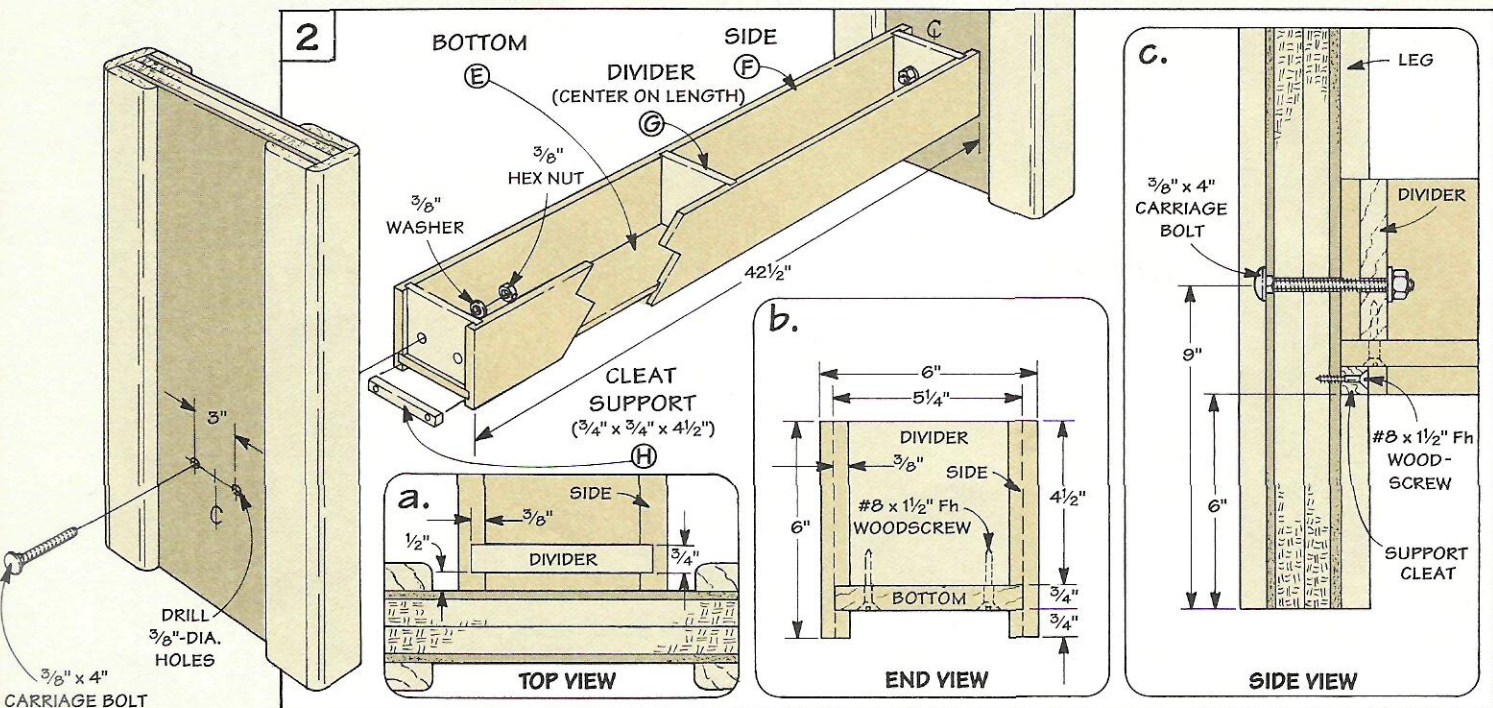

attach it to the legs. The ends of the beam fit over two *support cleats (H)* screwed to the inside of the legs, see Figs. 2 and 2c. To hold the stand together (and to make it easy to knock down), holes are drilled through the legs and the end dividers (G) before bolting the beam in place.

LID. Next, I cut a *lid (I)* from $\frac{3}{4}$ "-thick hardwood. It fits between the legs with a $\frac{1}{4}$ " of clearance for easy removal, see Fig. 3. To hold the lid in place, it's glued into grooves in a pair of *edging strips (J)*, see Fig. 3. This creates a shelf with a lip for temporary storage of lathe accessories.

MOUNTING RAILS. With the lid in place, there are only two things left to do. Two *mounting rails (K)* are screwed to the side trim pieces (C) so you can attach the top later, see Fig. 4. And to support the back edge of the top, an *apron (L)* is screwed to the end of these rails, see Fig. 4 and 4a.

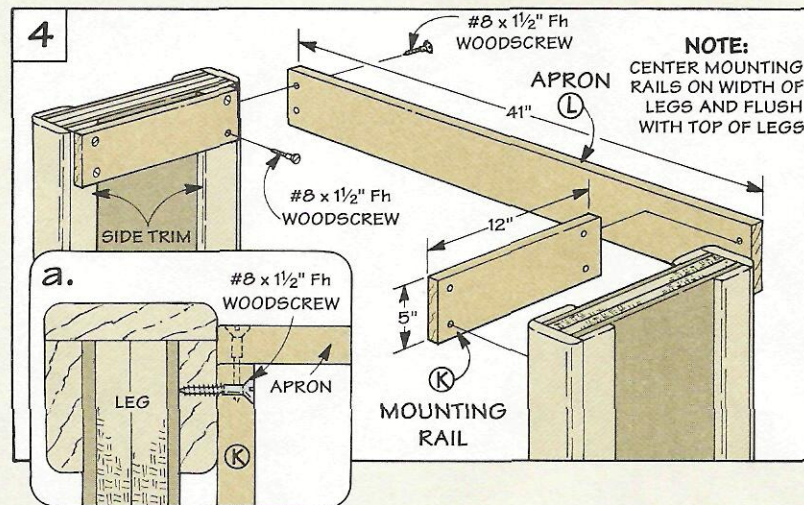
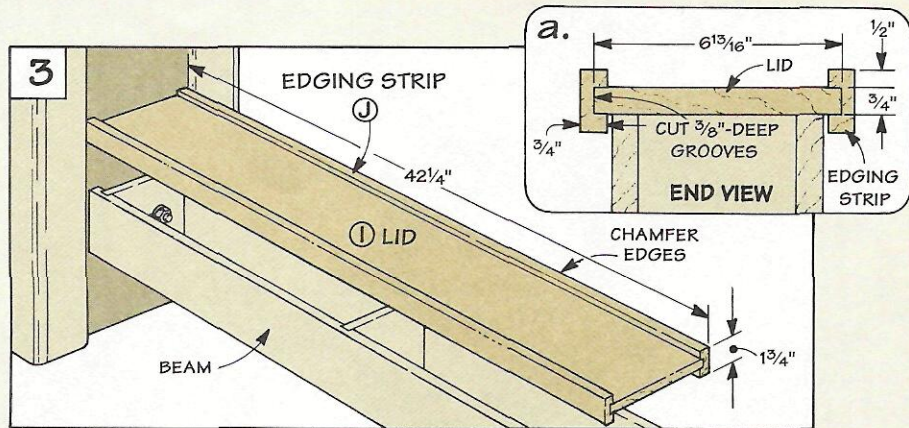

The Top

Like the legs, the top is built up from two layers of $\frac{3}{4}$ "-thick particleboard. Here again, these *top pieces (M)* are "sandwiched" between two *cover pieces (N)* made of $\frac{1}{4}$ "-thick Masonite, see Fig. 5.

TRIM. To cover the exposed edges, I "wrapped" the top with

$\frac{3}{4}$ "-thick hardwood trim pieces. After ripping the pieces to width to match the thickness of the top (2"), the *side trim (O)* and *front/back trim pieces (P)* are glued on. Then the top is completed by chamfering the top edges and corners of the trim pieces.

ATTACH TOP. Now it's just a matter of attaching the top to the base. To do this, center the top from side to side and front to back. Then, after drilling counterbored shank holes, the top is secured to the mounting rails with lag screws, see Fig. 5a.

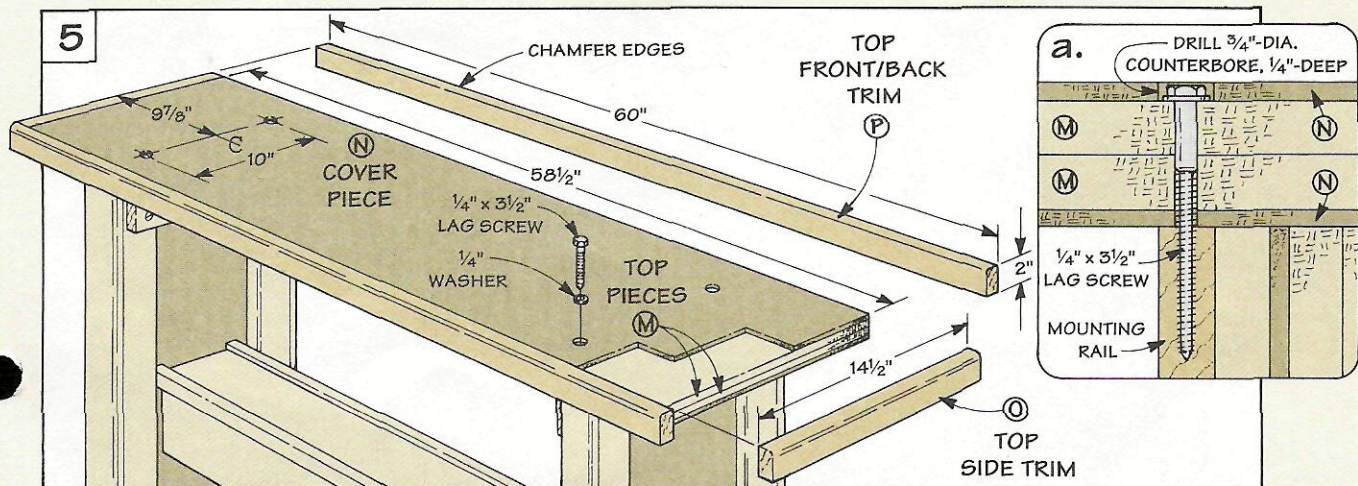

The Drawers

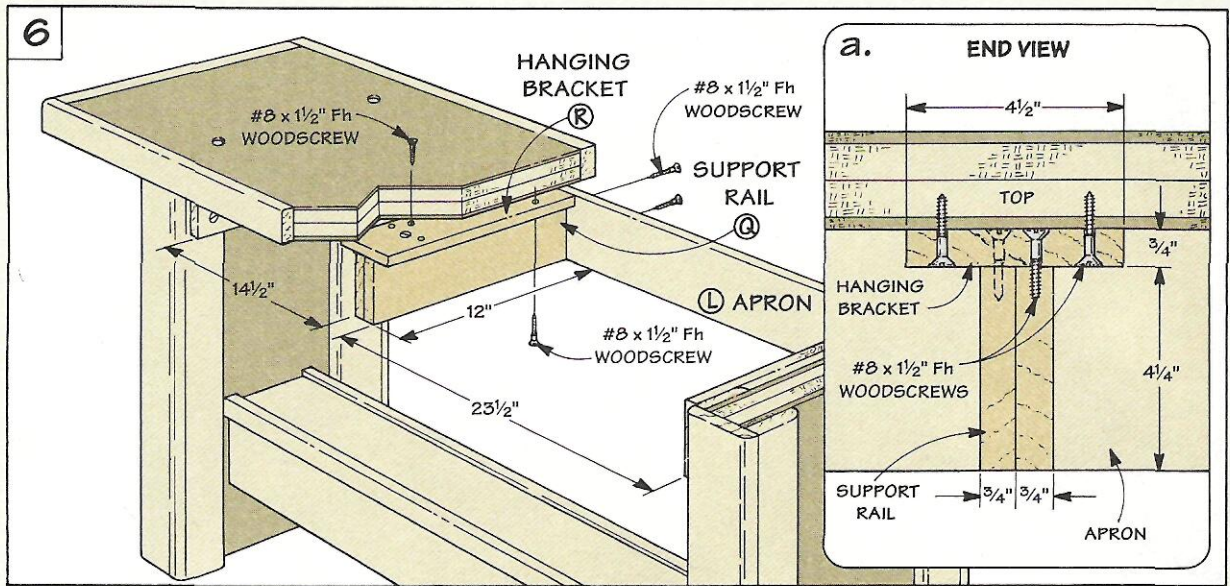

Once the top was in place, I built two drawers — a narrow drawer for chucks and faceplates, and a wide drawer for tool rests and long accessories. To provide easy access, the drawers are mounted on full-extension slides. (For more

on these slides, refer to page 30.) Note: If the motor on your lathe hangs *below* the headstock, you'll need to cut an opening in the top for the belt to fit through.

Whether you build one or both drawers, the openings are cre-

ated by screwing a simple T-shaped piece to the top, see Figs. 6 and 6a. It consists of a *support rail* (Q) that's made by gluing up two 3/4"-thick pieces and a *hanging bracket* (R) which is screwed to the top edge of the support rail.

Note: For additional support, the end of the support rail is screwed to the apron (L).

DRAWERS. After establishing the openings, work can begin on the drawers. They're held together with a simple, but strong joint — a locking rabbet, see Fig. 7b. Before cutting the joints though, you'll need to figure out the size of the drawer pieces.

DETERMINE SIZE. This is easy for the *drawer sides* (S). They're all the same length (12"). The tricky part is determining the length of the *front/back pieces* (T and U) for each drawer.

To do this, start by measuring the width of the opening. (In my case, this was 23 1/2" for the right-hand drawer.) Then subtract the amount of clearance you'll need for the drawer slides. (Each of the slides I used required 1/2" clearance on each side for a total of 1".)

The last thing to take into account is the locking rabbet joints. After subtracting 3/4" (3/8" on each

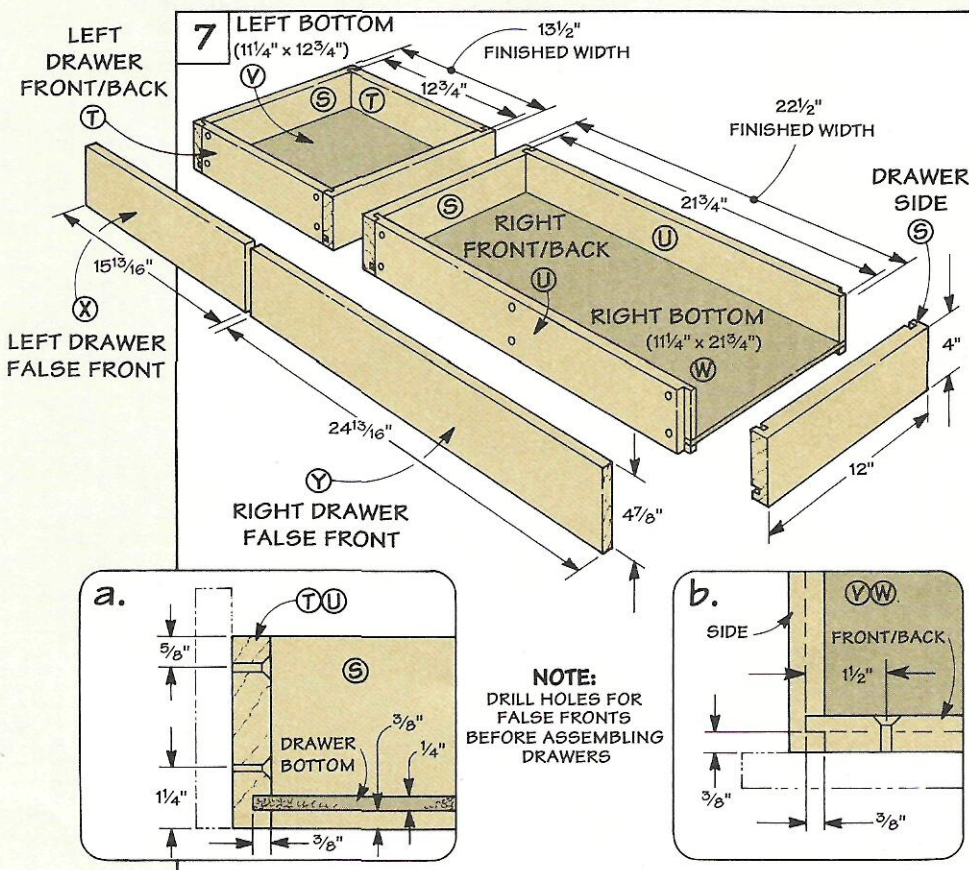

side), I ended up with front/back pieces that were $21\frac{3}{4}$ " long.

LOCKING RABBETS. Now you can cut the locking rabbets. This is just a matter of rabbeting the front/back pieces to form a tongue, see Fig. 7b. Then cutting dadoes in the side pieces to accept the tongue.

Before assembling the drawers, each piece is grooved to accept the *drawer bottoms* (V and W), see Fig. 7a. Then I drilled holes in the drawer fronts for two false fronts which are added later, see Fig. 7.

INSTALL SLIDES. With the drawers assembled, the slides can be installed, see Figs. 8a and 8b. I used a pair of heavy-duty 12" slides for each drawer, see page 31 for sources.

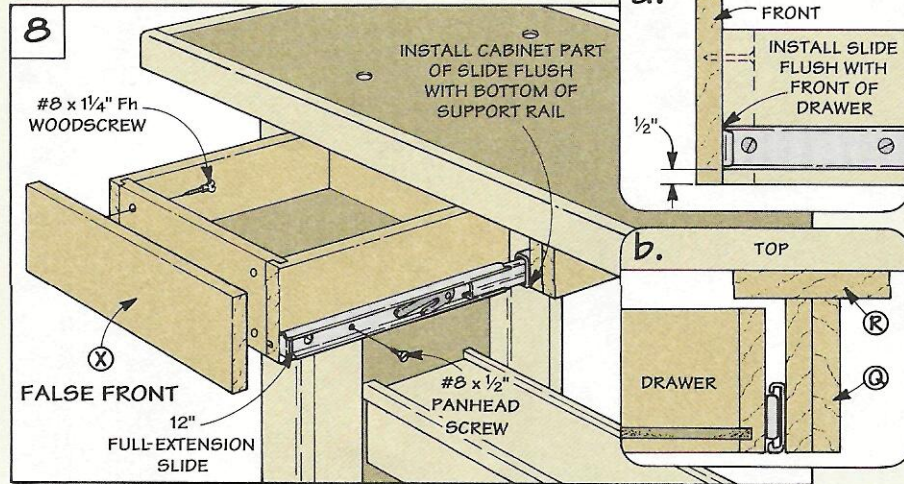

FALSE FRONTS. Next, to cover the slides and provide a uniform look across the front, I added *false fronts* (X and Y) to the drawers, refer to Fig. 7. I cut the fronts to allow $\frac{1}{8}$ " clearance around the

edges and ends. This lets you open and close the drawers without hitting each other. To complete the lathe stand, the false fronts are screwed in place using the holes that were drilled earlier.

Optional Tool Rack

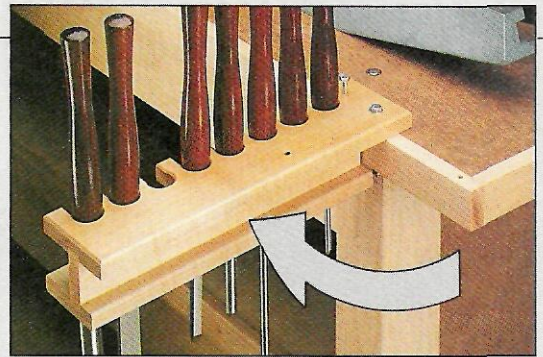
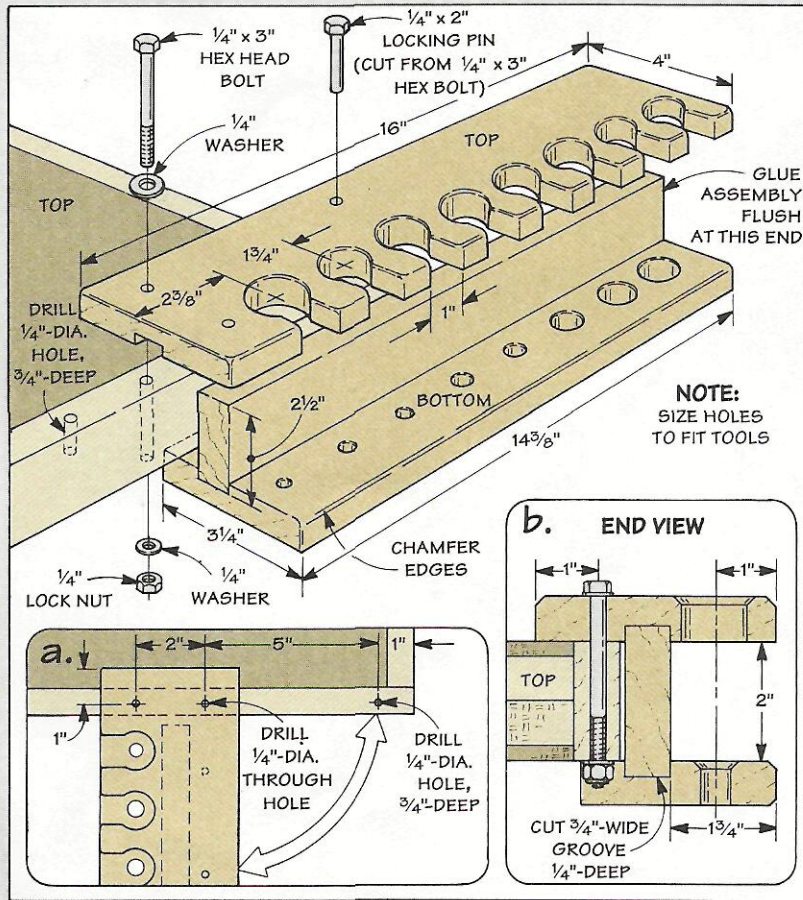

After completing the stand, I built a rack to hold my lathe tools. The unique thing about this rack is it pivots to give me easy access to my tools when I'm turning. And when I'm finished, it swings out of the way.

THREE PARTS. The rack is a three-part assembly that fits over the edge of the stand, see Drawing. To keep tools from falling out, there's a row of open-ended holes in the top that are slightly *smaller* than the thick part of the handles, see photo. The holes in the bottom are slightly *larger* than the diameter of the blades.

PIVOT. The rack pivots on a hex bolt that passes through a hole drilled through the top of the rack and the front trim piece of the lathe stand, see Detail b. Two other holes accept a steel pin that "locks" the rack in either the open or closed position, see Detail a,

Layout Techniques

By using some simple tips and techniques, you can greatly improve the precision of your woodworking.

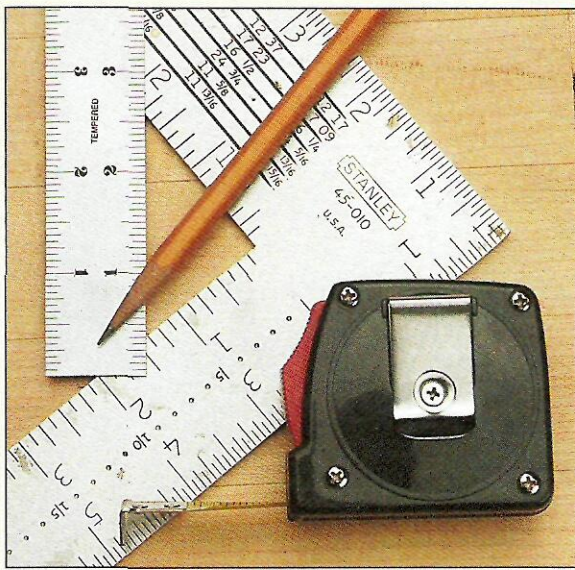

Let's face it, all woodworkers make mistakes. And most can be traced back to an error in measurement or layout. But I've found that many of these can be avoided by using some simple tricks and the right techniques.

The nice thing is none of these tricks require special tools. In fact, most of the layout problems I've come across can be solved with three basic tools: a 12" rule, a tape measure, and a square.

RULE. One tool I find myself reaching for all the time is a 12" rule. A good quality rule should have the markings *etched* into the rule — not just printed on top. Etching actually “cuts” the markings permanently into the surface of the rule. This way they won't wear off over time.

TAPE MEASURE. Another tool I use often is a tape measure. The

problem I've found with lower quality tapes is the markings can *vary* over their length. So before you buy one, check it in the store by extending the tape out a few feet and folding it back on itself, see Fig. 1. Then butt the edges of the tape together and make sure the markings line up.

SQUARES. In addition to a rule and tape measure, the squares in my shop get a lot of use. Regardless of the type, it's important that they be *truly* square.

Here's a quick way to check a square. Place it against a straight-edge and draw a line, see Fig. 2. Now flip the square to see if the blade lines up with the line. If it doesn't, the square isn't accurate.

TIPS. Once you can rely on your basic measuring tools, see the following four pages for tips to simplify almost any layout.

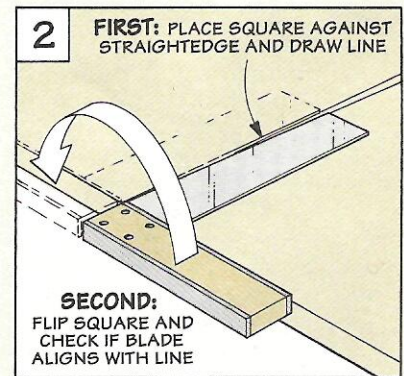
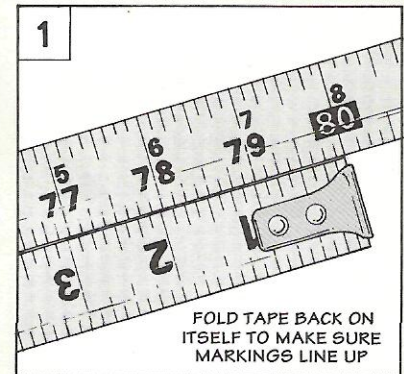

General Layout Tips

ACCURATE READINGS

Getting an accurate reading with a rule can be a challenge. Unless you look at the rule from directly overhead, the thickness of the rule can cause an error as you read the scale.

To prevent this, I stand the rule *on edge*, see Drawing. Holding the rule like this brings the markings flush with the workpiece and eliminates any error.

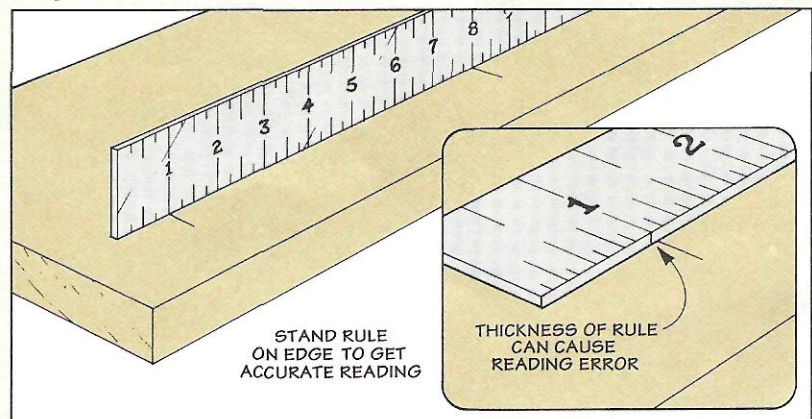

MEASURING TIP

Using a rule to get an accurate measurement on a workpiece can be tricky. The problem is getting the end of the rule to align *exactly* with the edge of the workpiece.

To solve this, I use a stop block, see Drawing. Just hold a scrap of wood up against the workpiece. Then push the rule against the block for an accurate measurement.

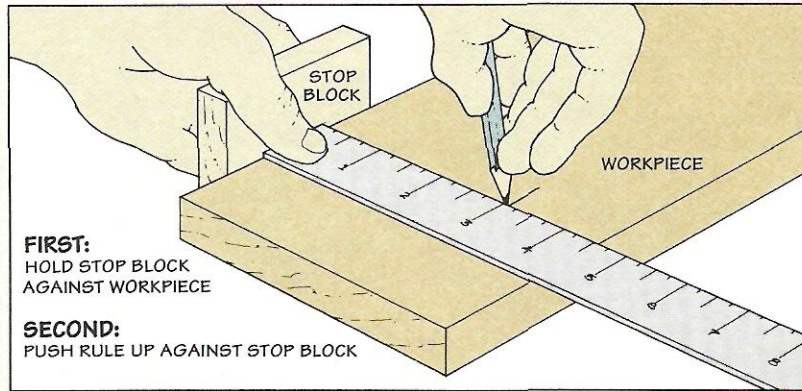

PARALLEL LINES

To quickly draw a line (or lines) parallel to the edge of a board, I use a combination square and a pencil, see Drawing.

Start by setting the square to the desired distance. Then position the head of the square against the board. Now with a pencil at the end of the blade, pull *both* toward you to draw the line.

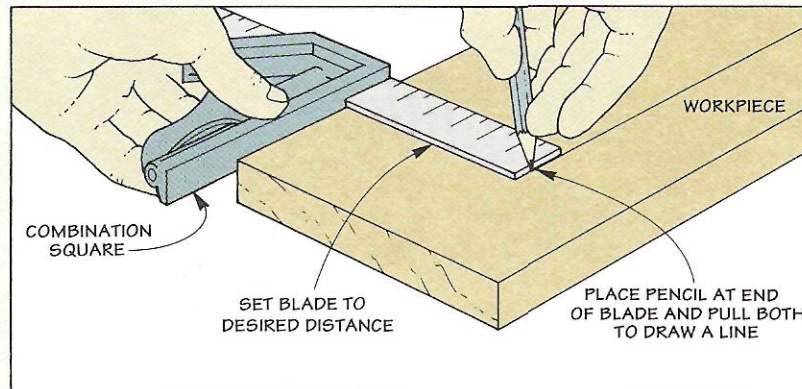

Measuring Inside Dimensions

SCRAP BLOCK

Measuring the inside of a drawer or a box can be a problem since the blade of a tape measure doesn't fit in a corner, see Detail.

One solution is to use a block and a tape measure, see Drawing. Use the tape to measure from the opposite side to the edge of the block, then add the length of the block to this measurement.

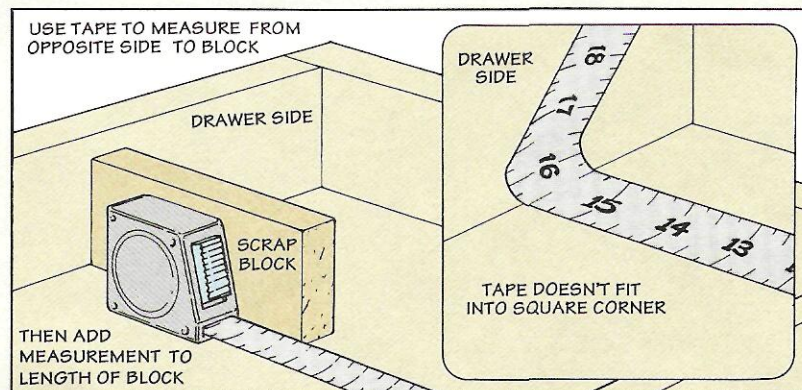

MEASURING STICKS

Another solution to finding an inside dimension is to use "measuring sticks," see Drawing. They're just scrap sticks with pointed ends.

To use them, just slip the sticks inside the box or drawer and extend the ends until the points touch the workpiece. Then clamp the sticks together and lift them out. Now simply measure from point to point.

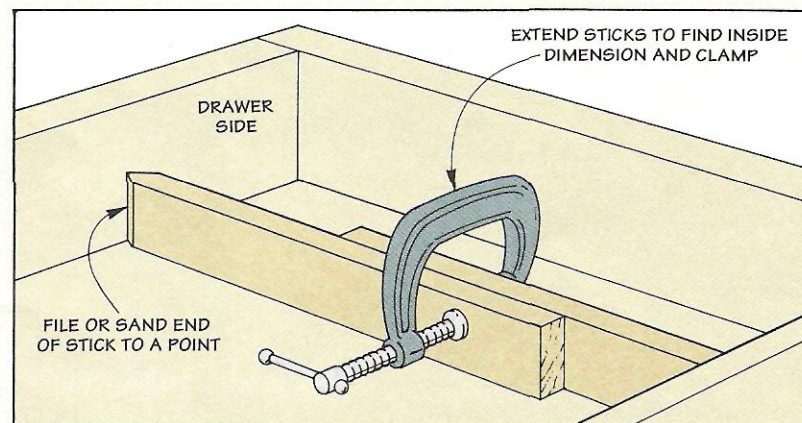

Center Finding Tips

CENTER OF A BOARD

Quick, what's the center of a board that's $5\frac{11}{32}$ "-wide? Or $1\frac{3}{16}$ "-thick? Here's a trick to finding the center without any complicated division.

First, position the "0" end of your rule at one end of the workpiece, see Drawing. Then angle the rule so the other end rests on a number easily divisible by two — the halfway point is the center.

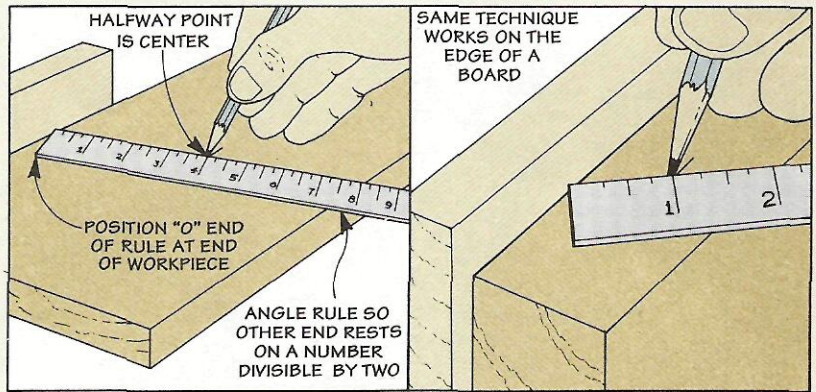

CIRCLES

Finding the center of a something round is easy with this simple jig, see Drawing. Just clamp a combination square to a framing square.

To use it, position the framing square so both "legs" touch the workpiece. Then draw a line along the top edge of the combination square. Now rotate the workpiece and mark another line to locate the center.

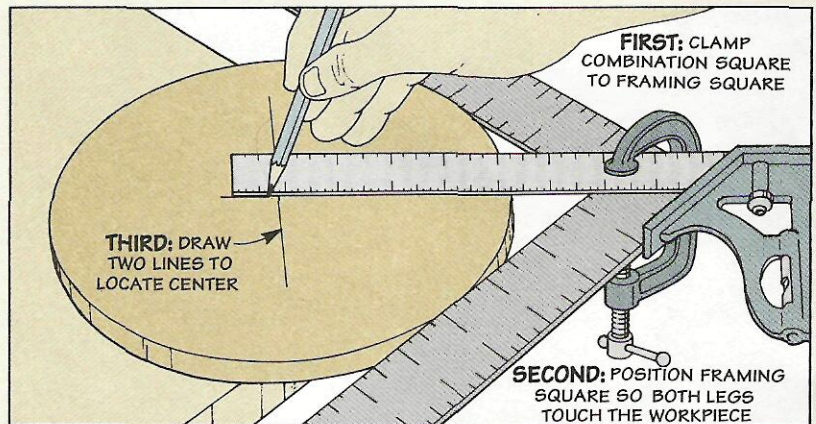

RECTANGLES & SQUARES

If you've ever had to mount a knob centered on a drawer front, you know how tricky it can be to get it *exactly* in the center.

The answer is simple — don't measure anything. Instead, draw a pair of diagonal lines from corner to corner to quickly locate the center. Note: This tip works for both square as well as rectangular workpieces.

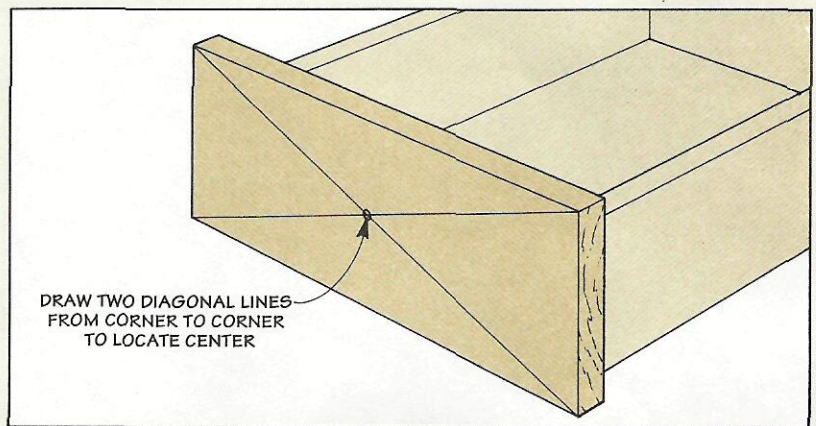

IRREGULAR SHAPES

To locate the center of a workpiece that *isn't* square (such as a turning blank), I use a shop-made template. It's just a piece of Plexiglas with circles scribed on the surface, see Drawing.

To use it, place it on the workpiece so the largest possible circle fits inside the edges of the workpiece. Now use the center of the template to mark the workpiece.

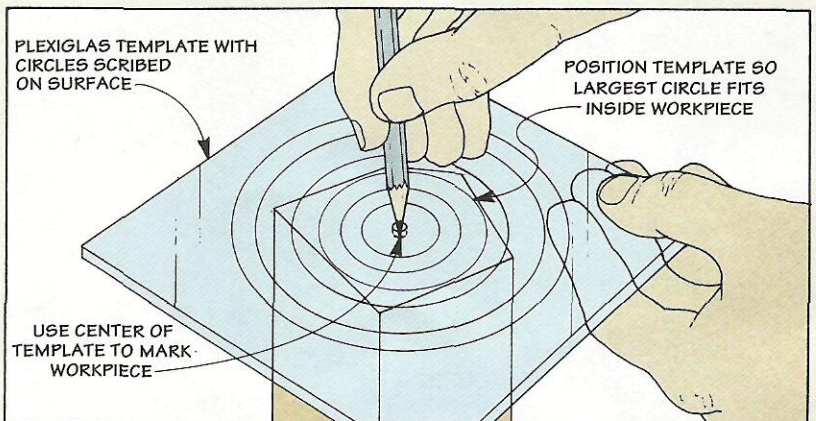

Measuring Round Objects

DIAMETERS

Measuring the diameter of a round object can be difficult. If the object is small, you can make a simple caliper with a rule and a pair of square blocks, see Drawing.

To find the diameter of the object, place it against the rule and butt the blocks up against the part. Then simply read the diameter on the rule.

If the object is large, you can use the same idea. But instead of a rule and blocks, use a framing square and a try square, see Drawing.

PLACE WORKPIECE AGAINST
RULE AND BUTT BLOCKS
UP AGAINST PART

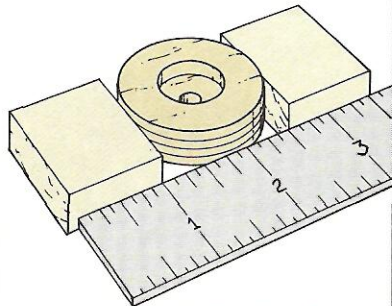

THEN READ THE
DIAMETER ON THE RULE

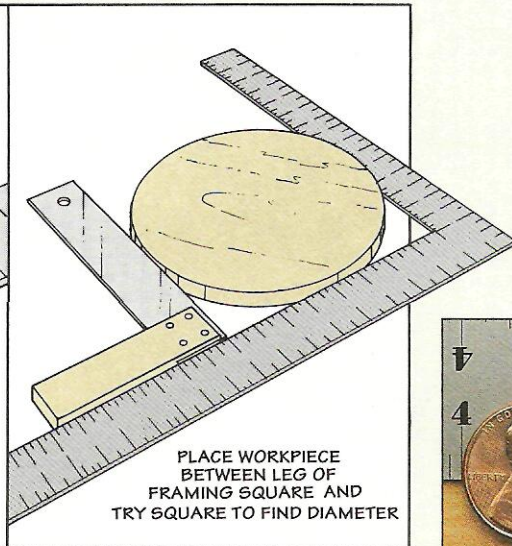

PLACE WORKPIECE
BETWEEN LEG OF
FRAMING SQUARE AND
TRY SQUARE TO FIND DIAMETER



A penny is exactly $\frac{3}{4}$ " It's handy for quick measuring or laying out a $\frac{3}{8}$ " radius on a corner.

CIRCUMFERENCE

How do you cut a piece of veneer tape or T-molding to fit around a round workpiece? A tape measure isn't flexible enough for small objects. And it's awkward to hold one around a large object.

The best way I've found to do this is to use masking tape. I just wrap it around the edge and splice it for an exact fit, see Drawing. Then to determine the circumference, just peel off the tape and measure it with a tape measure or rule, see Detail.

FIRST: WRAP MASKING TAPE AROUND
CIRCLE AND SPLICE ENDS TOGETHER

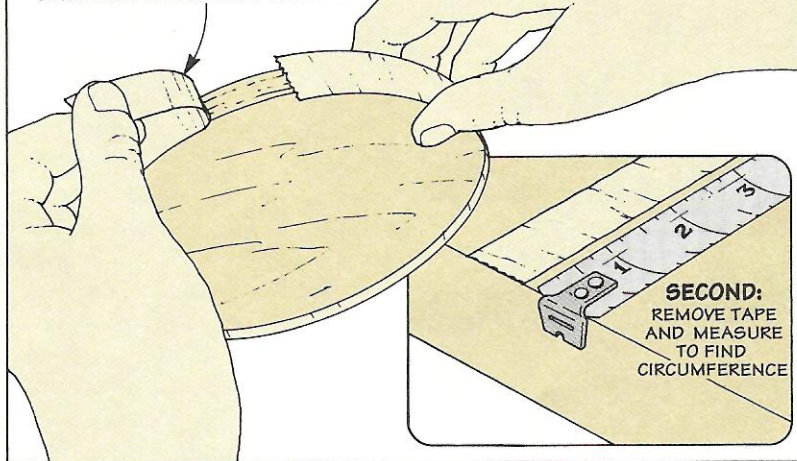

SECOND:
REMOVE TAPE
AND MEASURE
TO FIND
CIRCUMFERENCE

Drafting Tools for Layout

There are a number of drafting tools that I keep on hand in the shop to make working with circles and curves a lot easier.

Circle templates, flexible curves, and French curves can be found at your local art store. (For alternate sources, see page 31.)

A circle template is handy for finding the center on small objects or for laying out a radius, see photo. Flexible curves and French curves make quick work of transferring and laying out curves, see photo.

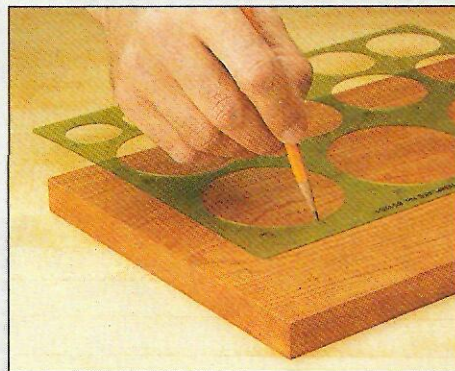

Templates: A circle template is a quick way to accurately lay out a radius or circle, or to find the center of a circle.

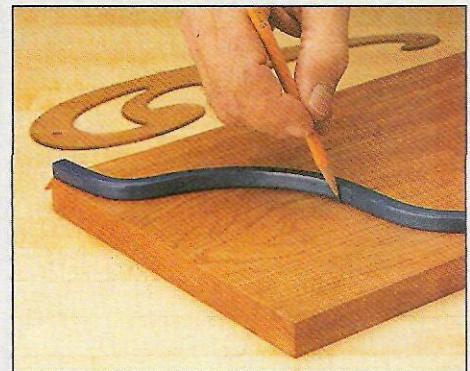

Curves: Flexible curves and French curves are handy for laying out or transferring graceful curves on a workpiece.

Sanding Products

A new breed of sanding products that claim to be longer lasting, maybe even "permanent."



Sometimes it seems that I spend more time changing sandpaper than I spend sanding. So when I came across some new products claiming to be longer-lasting, even "permanent," I was intrigued.

NEW BELTS

One product that has seen a lot of change recently is sanding belts. Two of the big names in abrasives (Norton and 3M) have developed a new line of sanding belts.

Both belts are easy to identify — the Norton belts are blue, and 3M's are purple, see photo below. Each feature a man-made mineral that lasts longer than garnet or aluminum oxide sandpaper.

The mineral Norton has developed is called *Norzon*. As this mineral gets dull with use, part of

the surface shears off to expose new sharp edges. In other words, it's self-sharpening.

3M's man-made mineral, *Regalite*, is a ceramic-like mineral that's harder than other abrasives. It lasts longer simply because it stays sharp longer.

BI-DIRECTIONAL. Besides using longer-lasting minerals, both companies have increased the life of their belts by making them bi-directional. This means you don't have to worry about direction when you load the belt on your sander — it goes on either way.

This provides an additional 15% to 25% more life from a belt that has started to lose its cutting power. Why? Because reversing a worn belt helps clean it by dislodging wood particles stuck in the surface. And at the same time

it exposes fresh minerals for additional sanding.

SPLICE. The secret to making a belt bi-directional is the *splice* that holds the belt together. On a conventional belt, the belt is overlapped and glued together, see Fig. 1. This creates a "bump" in the belt which can only travel in one direction without breaking.

To solve this problem, a butt joint is used, see Fig. 2. It's held together on the back side with heavy tape. This allows the belt to travel in either direction without coming apart. It also means the belt will run smoother with less "bumping."

GRITS. Bi-directional sanding belts are available from both Norton and 3M in grits ranging from 50 to 150 (*Norzon* is available in 180 grit). Note: Norton



◀ Norton's blue sanding belts use a self-sharpening mineral called *Norzon* to last longer.

◀ 3M's purple sanding belts feature a ceramic-like mineral that stays sharp longer than conventional sanding belts.

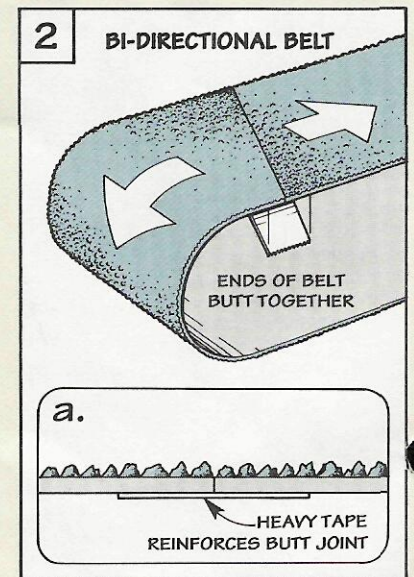
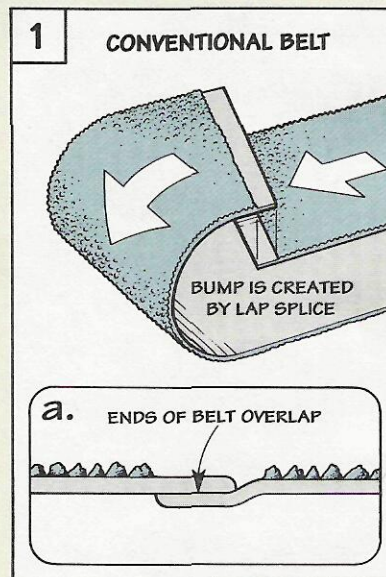

also manufactures *Norzon* in various size sheets and disks.

The *Norzon* belts I've used are aggressive—they take off stock quickly and are a good choice when you need to remove a lot of stock in a short period of time.

The only drawback is they cost three to five times as much as standard sanding belts. But they're worth it when you need to do heavy sanding, like leveling a workbench top.

Like the *Norzon* belts, 3M's *Regalite* belts cost more—but only about twice the price of a standard belt. They're not as aggressive as *Norzon*, but that's okay. For most sanding jobs, I prefer a belt that cuts slower and offers more control.

METAL SANDPAPER

A totally different approach to increasing the life of sanding products has been taken by two other companies: Problem Solvers and Sandvik. Both companies are using *metal* instead of minerals to provide the cutting action.

PERMA-SAND. *Perma-sand* is made by Problem Solvers, Inc., see photo above. It's manufactured by bonding bits of tungsten carbide to a flexible steel backing, see Drawing above. The carbide used is like the tips of your saw blades and router bits. It's

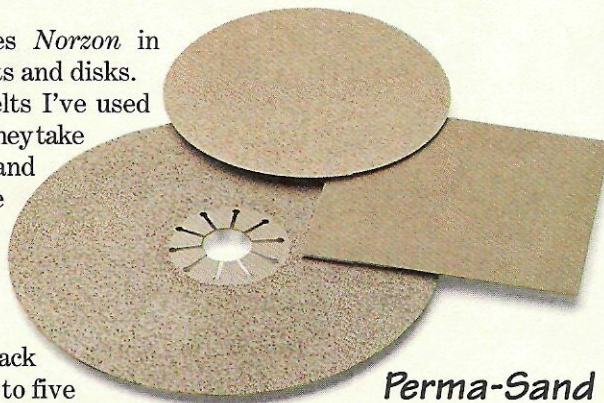

Perma-Sand

heat-resistant, tough, and remains sharp a very long time.

Perma-sand is available in 5", 6", 7", and 8" disks. And in quarter, third, and half sheets. All are available in grits ranging from an extremely coarse 24 to a fine 320.

I found the 60 to 150 grits of

New minerals and metal "sandpaper" create sanding products that last and last.

Perma-sand work best (the finer grits load up). They're especially useful for preliminary shaping and roughing work.

SANDPLATE. Another metal "sandpaper" called *Sandplate* is manufactured by Sandvik, see photo below. But unlike the products mentioned above, *Sandplate* is designed for hand sanding, not power sanding.

Sandplate is a thin steel plate that's etched with acid to create thou-

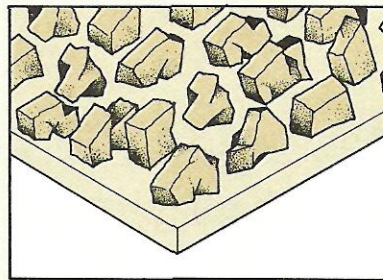

▲ On *Perma-Sand*, bits of tungsten carbide are "brazed" to a metal backing plate.

sands of small points, see Drawing below. If you were to examine *Sandplate* with a magnifying glass, you'd find a surface that resembles a cheese grater. The tiny points shave away material like a rasp.

Sandplate comes in various shapes and in three grits: coarse, medium, and fine. The adhesive-backed plates are designed for holders made by Sandvik, see photo below. But you could just as easily buy a replacement plate and attach it to a shop-made holder. As with *Perma-sand*, I found the lower grit *Sandplates* worked best.

The only drawback I've found to *Perma-sand* and *Sandplate* is they aren't readily available. (For a list of mail-order sources that carry these products, see page 31.)

A FINAL THOUGHT. With these new products you won't be changing sandpaper every few minutes. Now you can spend more of your time in the shop building, and not sanding.

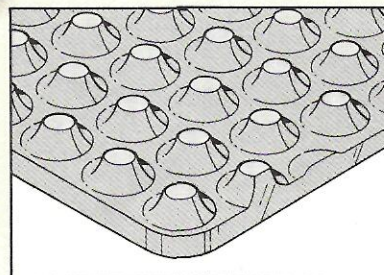

▲ *Sandplate* is made by etching a thin steel plate to produce thousands of small sharp points.

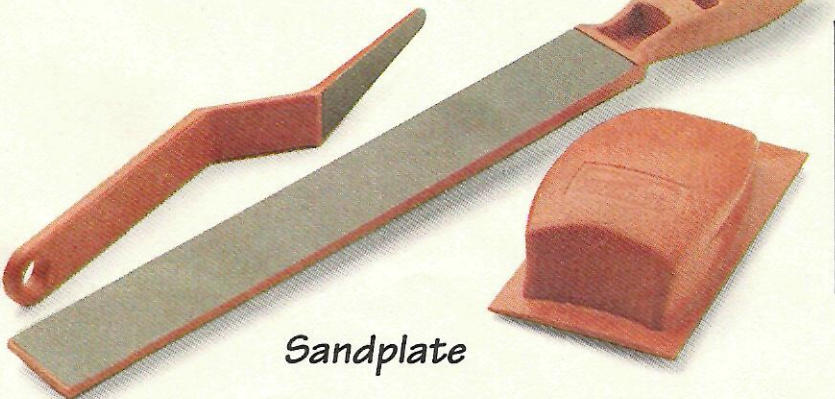

Sandplate

Shop Solutions

Pipe Clamp Edge Vise

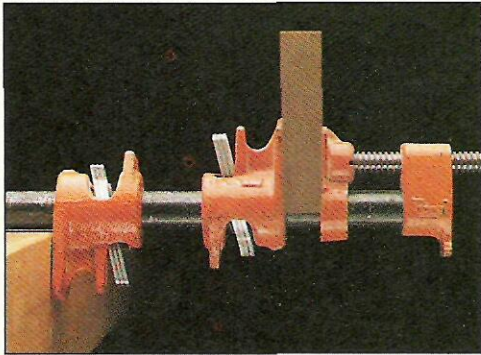

■ My workbench doesn't have a bench vise. So recently when edge jointing a board with a hand plane, I came up with a way to support the board on edge using pipe clamps, see photo.

To do this, you'll need two lengths of pipe threaded on both ends, with both pipes being slightly longer than the width of your bench. Also, you'll need two sets of clamp fixtures for each

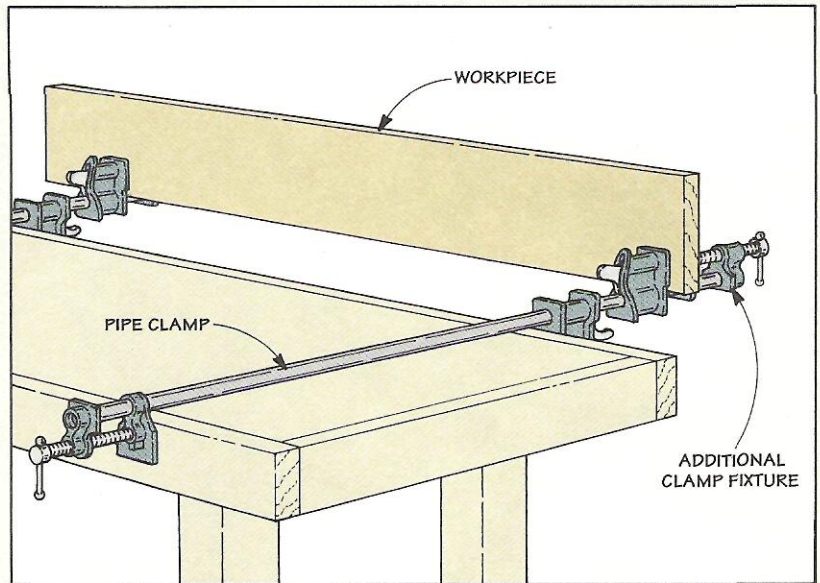

pipe, see Drawing. (If you're using the pipe from your clamps, but it's only threaded on one end, your local hardware store should be able to thread the other end.)

Then to clamp the board in place, just stand it on edge and tighten the clamp.

*Joe Planisky
Phoenix, Arizona*

Supports for Cutting Plywood

■ Cutting a full sheet of plywood by yourself can be quite a challenge. The easy part is guiding the saw — the tricky part is supporting the workpiece *and* catching the waste.

To do this, I use a pair of sawhorses and four pipe clamps, see Drawing. The clamps serve as extra "helpers" to support the workpiece and waste.

Depending on the length of your clamps, you may need to cut a spacer to fill in the gap between the clamp head and the plywood. (I cut my spacers from scrap 2x4.)

Note: Position the clamps far enough back from the cut line so the saw will clear.

*James T. Wypijewski
Tucson, Arizona*

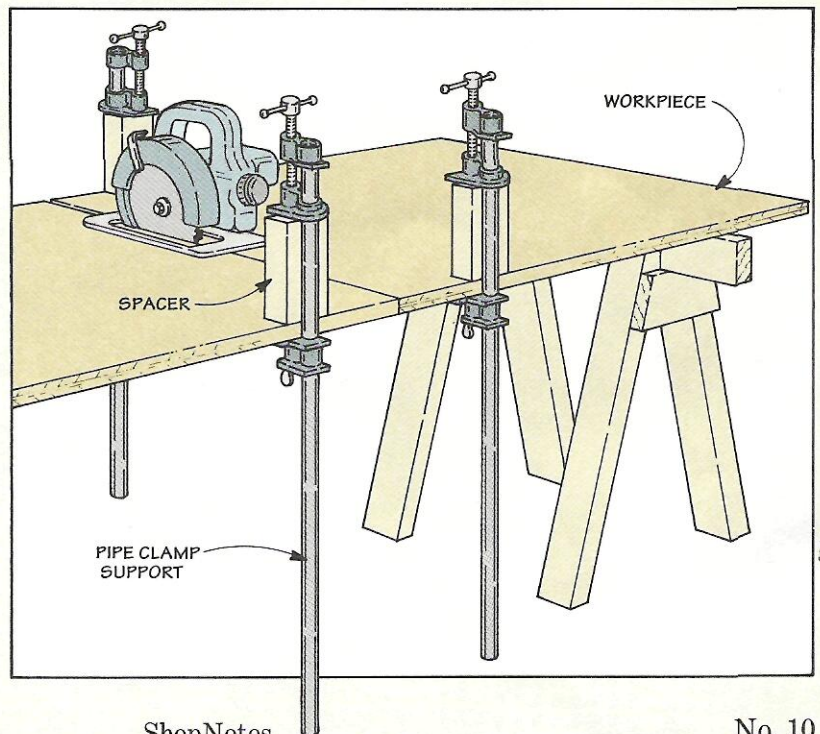

Auxiliary Band Saw Fence

■ Ripping narrow strips safely on my band saw is difficult. The height of the rip fence prevents me from lowering the upper guide assembly down close to the workpiece. This means too much blade ends up being exposed.

So I made an L-shaped auxiliary fence that clamps to the rip fence, see Drawing. The base of the auxiliary fence holds the workpiece out so the guide assembly can be lowered to cover the exposed blade.

*Tim Willis
Athens, Georgia*

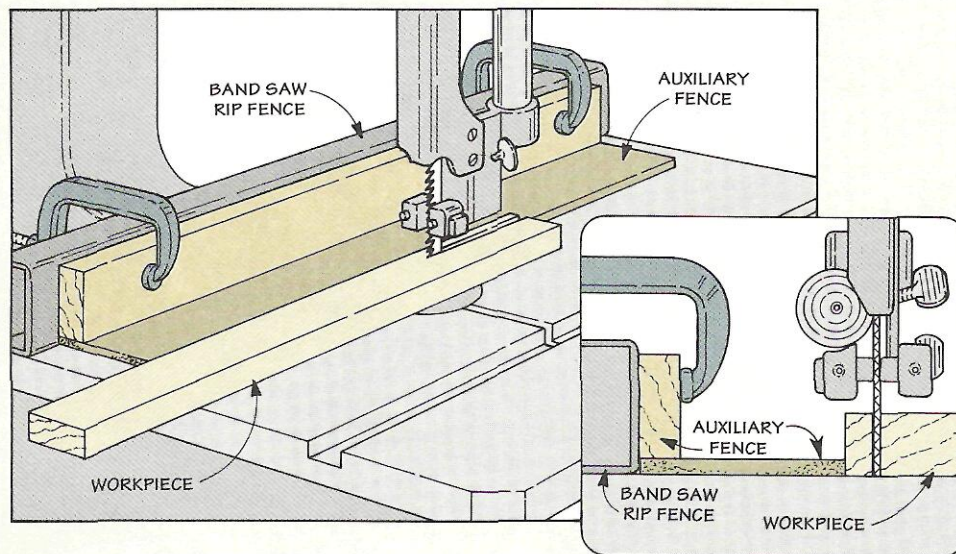

Quick Tips

■ I noticed in the rust removal article in *ShopNotes* No. 7 you didn't mention white vinegar. I've been using it as a rust remover for years on small parts and old tools — with good results.

Just place the rusty part in a sealed container that's filled with white vinegar. Then change the

vinegar daily until the rust is gone. To help speed up the process a little, loosen the rust with a plastic scouring pad between each soaking.

The nice thing is, a gallon of white vinegar costs around \$2.

*Bill Schmidt
Oakdale, California*

■ I've ruined a number of perfectly good glue brushes by forgetting to rinse them out. So now when I'm through with a brush, I'll immediately drop it in a small container full of water that I keep on a shelf in the shop.

*Bruce McCampbell
Rawlins, Wyoming*

Shop-Made Cord Tie

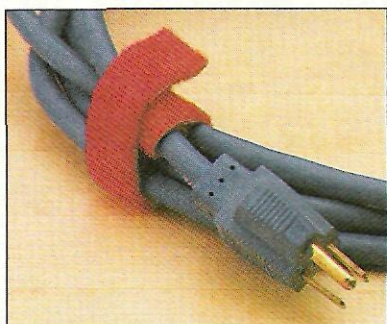

■ To keep the cords on my portable power tools neatly coiled, I secure them with a shop-made tie, see photo. The tie is made from two pieces of adhesive-backed hook and loop fastener (Velcro) and is available at most hardware stores, see Drawing.

The advantage to using this type of tie over a string or a rope

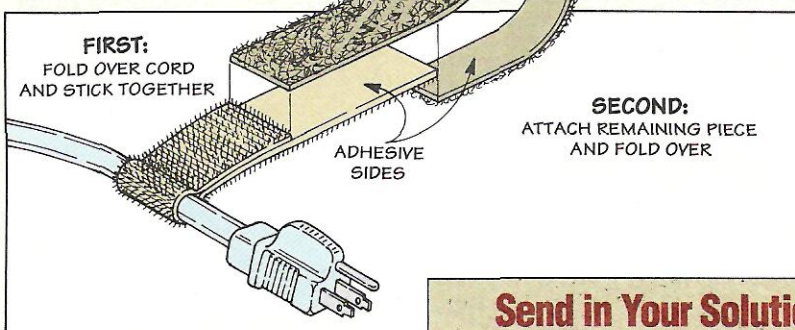

is it's always attached to the end of the power cord — I don't have to hunt around the shop for it. But best of all, a coiled cord can be tied quickly.

For most of my cords, I use 6"-long ties. For longer cords, like extension cords, I use 12" ties.

*Tom McArdle
Miami, Florida*

Send in Your Solutions

If you'd like to share your original solutions to problems you've faced, send them to: *ShopNotes*, Attn: Shop Solutions, 2200 Grand Avenue, Des Moines, IA 50312.

We'll pay up to \$200 depending on the published length. Send an explanation along with a photo or sketch. Include a daytime phone number so we can call you if we have questions.

Full-Extension Drawer Slides

Full-extension slides let you pull a drawer all the way out of a cabinet so there's no wasted space in the back.

One way to increase the usable space in a drawer is to install full-extension drawer slides. These slides let you pull the drawer all the way out of a cabinet which gives you easy access to what's inside — even the small stuff that tends to “migrate” to the back corners.

CHANNELS. The secret is a system of telescoping steel “channels.” As the drawer is opened, these channels cantilever the drawer out in front of the cabinet.

With the channels fully extended, you'd think the drawer would tend to sag. But that's not the case. They're designed to carry loads that range from 75 to 150 pounds — strong enough for a whole drawer full of tools.

BEARINGS. Even with that much weight, the operation is smooth. And the slides are about

as quiet as a caterpillar crawling across a pool table. That's because the channels ride on a line of steel (or nylon) ball bearings.

To prevent the bearings from working their way to one end of the slide, they're held in place with retaining clips, see Fig. 1a. Distributing the bearings evenly like this keeps the drawer from wobbling.

INSTALLATION. Although full-extension slides are precision made, you don't have to be a jeweler to install them. Just press a “quick-release” lever to separate the slide into two parts, see Fig. 1. Then attach one part to the cabinet and the other to the drawer. Note: Cabinets with a

face frame require a slightly different installation, see the box below.

ADJUSTMENT. Once the slides are installed, the horizontal slots in the cabinet part of the slides allow you to move the drawer in or out, see Fig. 1. And the vertical slots in the drawer part let you adjust it up or down.

BRANDS. Full-extension slides are manufactured by several different companies, and are available through a number of woodworking catalogs. (For a list of sources, see page 31.)

Note: Since the clearance requirements vary depending on the slide, it's best to have the slides in hand *before* you build the project.

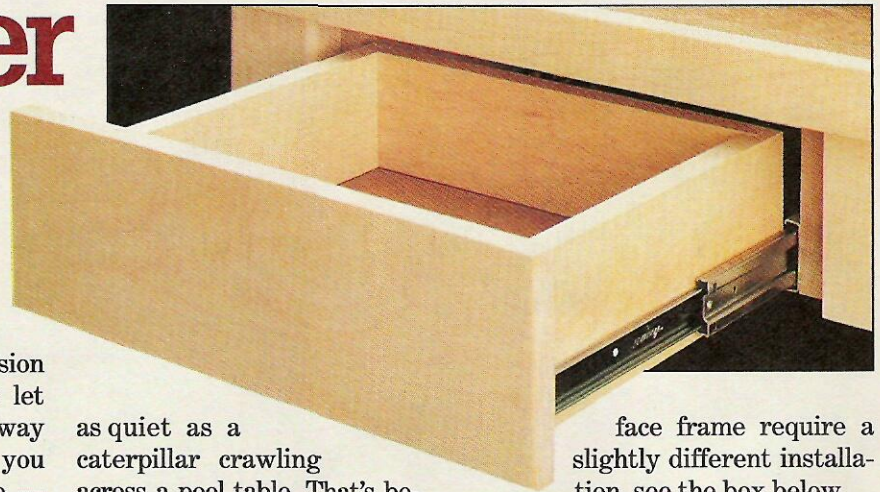

Face-Frame Installation

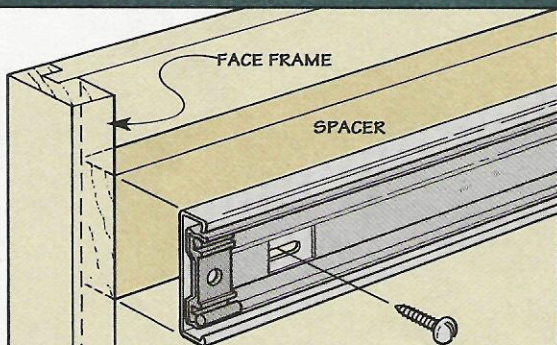

To install a slide on a cabinet with a face frame, use a spacer to “build out” the back of the slide flush with the edge of the frame.

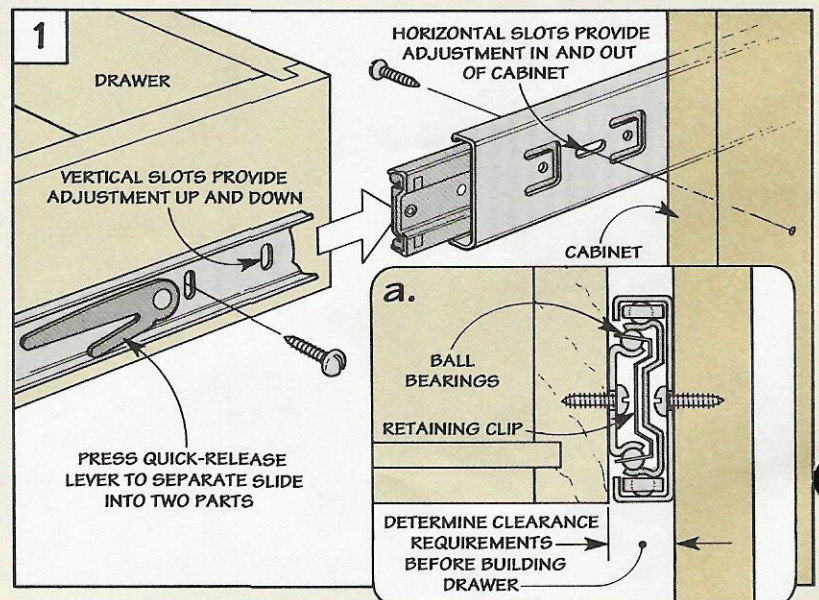

Sources

ShopNotes Project Supplies is offering some of the hardware and supplies needed for the projects in this issue.

We've also put together a list of other mail order sources that have the same or similar hardware and supplies.

INDEXING JIG

The micro-adjustable Indexing Jig (shown on page 4) attaches to the fence on your router table and eliminates the guesswork when positioning the fence.

Note: The Indexing Jig is sized to fit the Router Table featured in *ShopNotes* No. 1. But it will fit any router table that has 10" to 18½" from the center of a router bit to the back edge of the table.

ShopNotes Project Supplies is offering a hardware kit that includes all the hardware needed to make the Indexing Jig. All you need to supply is the plywood, ¼"-thick Masonite, and a 6" metal rule for the indicator.

S10-6810-100 Indexing Jig Hardware Kit\$19.95

LATHE STAND

One of the best ways to improve the performance of a bench-top

lathe is to attach it to a heavy-duty stand like the one shown on page 16. Sturdy construction and extra weight (ballast) combine to effectively deaden any unwanted vibration.

The end result is a lathe that runs smoother and quieter. In addition, this stand features two convenient pull-out drawers and an optional lathe tool rack.

ShopNotes Project Supplies is offering a hardware kit for the Lathe Stand. The kit includes all the hardware needed to build the stand, along with two pairs of 12" Accuride full-extension slides for the drawers.

All you need to supply is the particleboard, ¾"-thick hardwood, ¼"-thick Masonite, and sand for "ballast." Note: You'll also need the correct size mounting bolts, nuts, and washers to attach your lathe to the stand.

S10-6810-200 Lathe Stand Hardware Kit\$39.95

DRAWER SLIDES. We used Accuride slides in the Lathe Stand, but full-extension drawer slides are also made by Blum, Grant, and Knap & Vogt. See Mail Order Sources below for companies that carry full-extension slides.

LAYOUT TOOLS

The article on Layout Techniques (featured on page 22) describes a number of layout tools including: squares, rules, circle templates, and flexible and French curves.

Many of these are available at hardware stores and art centers. They're also available from some of the mail order sources below.

SANDING PRODUCTS

The sanding belts featured on page 26 last longer because they use new man-made minerals and a special splice that makes them bi-directional. They're available at some hardware stores. If you can't find them locally, see Mail Order Sources below.

Note: The "metal" sandpaper described in the article may be available at local woodworking stores. Or it can be ordered from some of the sources listed below.

DRILL BIT CASE

The lid on the Drill Bit Case (shown on page 10) is fastened to the case with a hinge and a hook. This hardware is available at many hardware stores, or from some of the sources listed below.

MAIL ORDER SOURCES

Similar hardware and supplies may be found in the following catalogs. Please call each company for a catalog or for ordering information.

Constantine's
800-223-8087
Full-Extension Drawer Slides, Layout Tools, Hardware

Garrett Wade
800-221-2942
Layout Tools

Trendlines
800-767-9999
Full-Extension Drawer Slides, Layout Tools, 3M Sanding Belts

Problem Solvers, Inc.
800-397-6980
Perma-Sand
Woodcraft
800-225-1153

Full-Extension Drawer Slides, Layout Tools, Norton Sanding Products, Hardware

The Woodsmith Store
515-255-8979
Full-Extension Drawer Slides, Layout Tools, Sandplate, Hardware

Woodwerks
800-243-8665
Layout Tools, Sandplate

The Woodworker's Store
612-428-3200
Full-Extension Drawer Slides, Layout Tools, Hardware

ORDER INFORMATION

BY MAIL

To order by mail, use the order form that comes with the current issue. The order form includes information on handling and shipping charges, and sales tax.

If the mail order form is not available, please call the toll free number at the right for more information on specific charges and any applicable sales tax.

BY PHONE

For fastest service use our Toll Free order line. Open Monday through Friday, 7:00 AM to 7:00 PM Central Time.

Before calling, have your VISA, MasterCard, or Discover Card ready.

1-800-444-7527

Note: Prices subject to change after September 1, 1993.

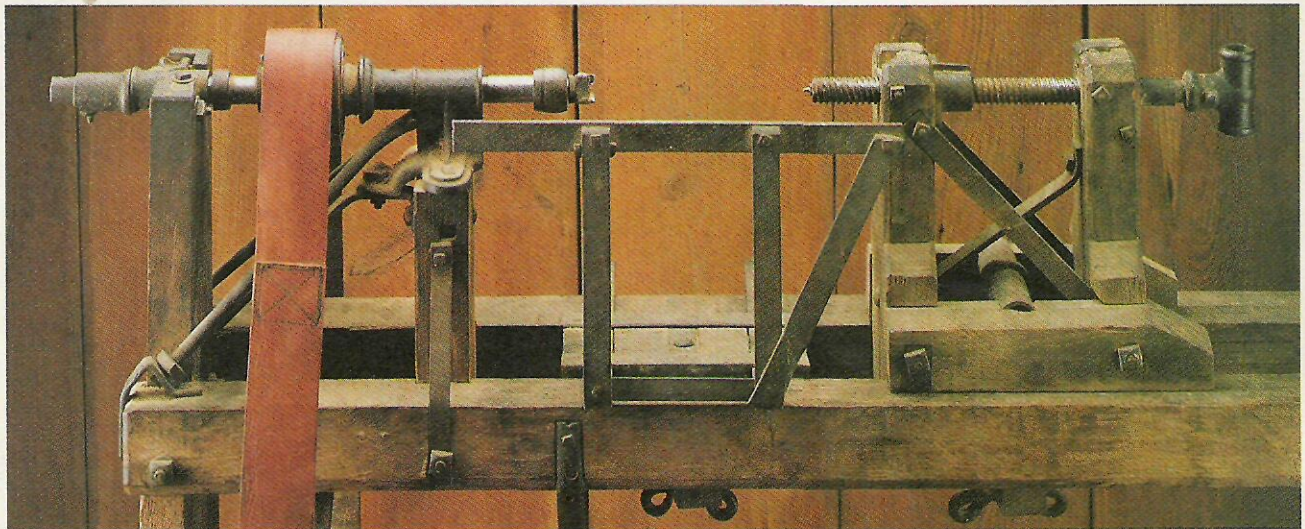
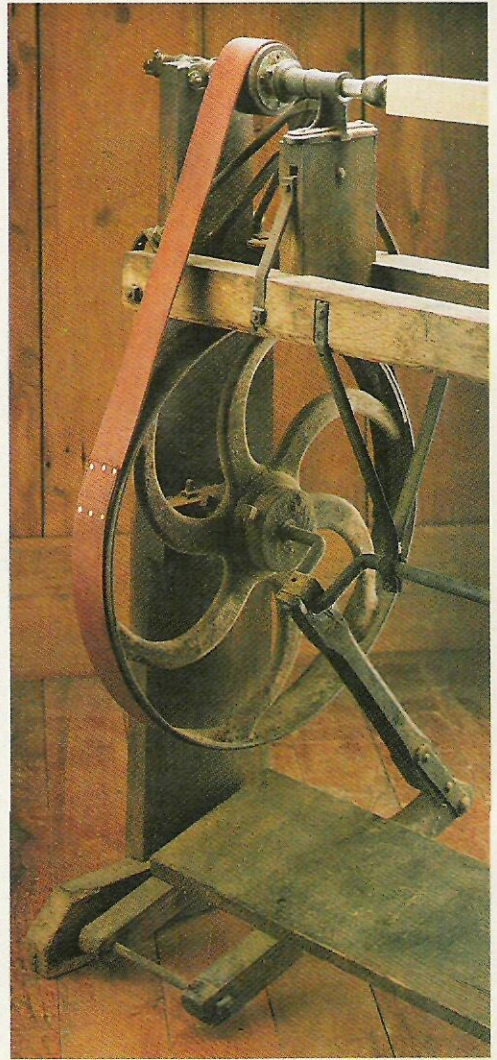
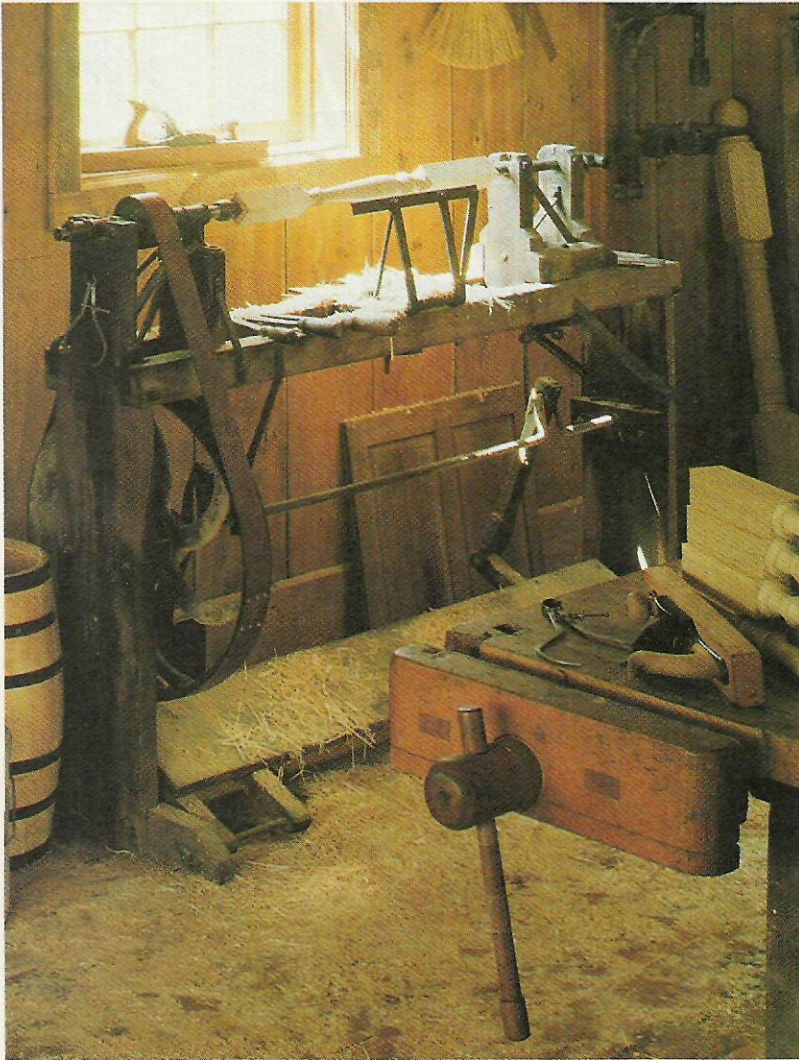

Scenes From the Shop

Before electricity, lathes (like the one shown above) were often driven by a treadle that was pumped by the turner's foot. The cast flywheel was put into motion by

stepping on the treadle. This motion was then transferred to the workpiece (chucked between the fixed head and movable tailstock) by way of a large leather belt.