

TIPS • TOOLS • TECHNIQUES

# ShopNotes®

Vol. 2

Issue 11



- Power Miter Saw Station
- Random-Orbit Sanders
- Sharpening without Stones
- Shop-Made Hand Plane



# ShopNotes®

Issue 11 September 1993

**EDITOR** Donald B. Peschke

**EXECUTIVE EDITOR** Douglas L. Hicks

**MANAGING EDITOR** Terry J. Strohman

**ASSOCIATE EDITOR** Richard S. Peters

**ASSISTANT EDITOR** Tim Robertson

**CONTRIBUTING EDITOR** Philip A. Totten

**CREATIVE DIRECTOR** Ted Kralicek

**ART DIRECTOR** Cary Christensen

**SENIOR ILLUSTRATOR** Kurt Schultz

**ILLUSTRATORS** Will Niskanen  
Roger Reiland  
Mark Higdon

**PHOTOGRAPHER** Crayola England

**DESIGN DIRECTOR** Ken Munkel

**SENIOR DESIGNER** Jan Hale Svec

**DESIGNER** Kent Welsh

**SHOP MANAGER** Steve Curtis

#### CIRCULATION

*Circulation Director:* Liz Bredeson • *Subscription Manager:* Phyllis Jessen • *Circulation Analyst:* Rod Cain • *Newsstand Sales:* Kent A. Buckton

#### PUBLISHING SERVICES

*Associate Editor:* Gordon C. Gaipe • *Sr. Graphic Designer:* Robert H. Whitmer

#### CORPORATE SERVICES

*Controller:* Paul E. Gray • *Accounting:* Laura Thomas • *Bookkeeping:* Julianne Spears • *Info. Services Manager:* Joyce Moore • *Electronic Pub. Coordinator:* Douglas M. Lidster • *Administrative Assts.:* Cheryl Scott, Julia Fish • *Receptionist:* Jeanne Johnson • *Bldg. Maint.:* Ken Griffith

#### PROJECT SUPPLIES

*Marketing Director:* Robert Murry • *Catalog Art Director:* Cindy Jackson • *Catalog Products Manager:* Bob Baker • *Project Supplies:* Linda Jones • *Technical Support:* Jeff Janes • *Systems Operator:* Linda Morrow • *Receptionist:* Keri Lee

#### CUSTOMER SERVICE

*Manager:* Valerie Wiese • *Supervisor:* Jennie Enos • *Customer Service Representatives:* Jennifer Murphy, Joy Johnson, Sara Kono, Ami Blanshan, Anna Cox, Chris Lo

#### SHIPPING DEPARTMENT

*Supervisor:* Jerry Carson • *Fulfillment:* Gloria Sheehan, Don McVey, Chuck Carlson, Sylvia Carey

ShopNotes © (ISSN 1062-9666) is published bimonthly (Jan., March, May, July, Sept., Nov.) by Woodsmith Corporation, 2200 Grand Ave., Des Moines, IA 50312. ShopNotes © is a registered trademark of Woodsmith Corp. ©Copyright 1993 by Woodsmith Corporation. All rights reserved.

Subscriptions: Single Copy, \$4.95. One year subscription (6 issues), \$19.95. Two years (12 issues), \$35.95. Canada/Foreign, add \$4.00 per year.

Second Class Postage Paid at Des Moines, IA and at additional offices.

Postmaster: Send change of address to ShopNotes, Box 11204, Des Moines, IA 50340-1204

Subscription Questions? Call 1-800-333-5854, 8am to 5pm, Central Time, weekdays.

PRINTED IN U.S.A.

## EDITOR'S NOTE

**W**e purchased a portable miter saw for the shop several years ago. And it has proven to be a very popular tool around here. In fact, our miter saw is so popular that it never seems to be in the shop. Someone is always using it for some project at his house.

One reason our miter saw is so popular is it can be easily moved to wherever it's needed. But the size of the saw also creates a problem. Since the table and fence of the saw are relatively short, it can be difficult to work with long pieces of stock.

What we wanted was a way to extend the length of the table and fence and still keep the saw portable. After trying several different approaches we finally came up with the Portable Miter Saw Station shown on page 16.

**MITER SAW STATION.** The miter station features two extension wings that safely support long workpieces. We even came up with a way to extend the saw fence and add a sliding stop system.

But the thing I like best about the Miter Saw Station is the way it works when it's *not* being used.

To make the station portable, the extension wings can be tucked under the saw. The fence system can be knocked down and stored. There are even handle cutouts to make it easy to carry.

**HAND PLANE.** Another project that I've been wanting to tackle for a long time is a shop-made hand plane. So I got together with our designers and explained what I had in mind — a small wood bodied plane that worked well, looked good, and was easy to build.

The trickiest part to building a plane is coming up with a way to hold the blade securely in place. Typically, this is done with a wedge-shaped piece of wood. But it can take a lot of fitting and adjustment to get the wedge to hold the blade securely.

So we decided to take a different approach. Instead of using a wedge to secure the blade, we simply screwed the blade in place. For more on this, see the article on page 10.

Normally, I would tell you more about what's in the rest of this issue. But the last couple of days around here haven't been exactly normal.

**THE FLOOD.** As I write this, we're in the middle of a real crisis. The city of Des Moines is suffering the worst flood on record. We don't have running water. Our Customer Service and Project Supplies Offices were flooded. And water is lapping at the door of our warehouse. Not the best of times.

The strange thing is, I feel lucky. No one that works here was hurt or lost a home to the flood waters.

We were able to save most of the equipment and supplies from our Customer Service and Project Supplies offices. Since the publishing offices didn't receive any major damage, we're moving Customer Service and Project Supplies to this building. Right now things are a bit chaotic, so if you call please be patient. We'll handle your questions and orders as quickly as possible.

The flood has also made me realize how lucky I am to work with such a great group of people.

When the flood waters started to rise, I didn't even have to ask for help. The word just got around. Before I knew it, we had crews of people pitching in to move computer equipment to higher ground. It was good thing, because within a few hours everything was under water.

As the water started to go down, people spent days sloshing through mud and debris to remove the rest of the office equipment and records. To all those people who spent so much of their own time and effort to help, I can't thank you enough.

# Contents

## Drill Press Table Counterweight \_\_\_\_\_ 4

All it takes is finger pressure to move your drill press table once you've installed this simple counterweight.

## Pipe Clamp Rack \_\_\_\_\_ 6

Keep your pipe clamps organized and right at hand with this easy to build wall-mounted rack.

## Radial Arm Saw Return \_\_\_\_\_ 7

Make your radial arm saw safer to use with this accessory. It returns the blade after each cut and keeps it there.

## Random-Orbit Sanders \_\_\_\_\_ 8

A look at random-orbit sanders. What makes them different, how they work, and techniques for sanding.

## Hand Plane \_\_\_\_\_ 10

There's nothing complicated about making your own hand plane. Especially when you start with a special blade set and build the plane around it.

## Portable Miter Saw Station \_\_\_\_\_ 16

You can make your power miter saw safer and more accurate to use with this work station. A unique design offers support for long stock, yet knocks down easily for storage.

## Sharpening with Sandpaper \_\_\_\_\_ 24

You can achieve a razor sharp edge on your hand tools with this quick and inexpensive technique.

## Shop Solutions \_\_\_\_\_ 28

Seven Shop-Tested Tips: Frame and Panel Jig, Sanding Belt Storage Rack, Tip for Clamping Edging, Plugging Mortises, Peel and Stick Veneer Tip, No-slip Waterstones, and a Guide for Power Sanding.

## Plywood Grades \_\_\_\_\_ 30

What the various grades of hardwood plywood mean. And how to use them to your advantage.

## Sources \_\_\_\_\_ 31

Hardware, project supplies, and mail order sources for the projects in this issue.

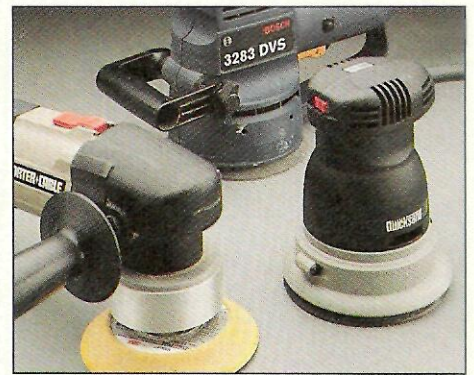

Random-Orbit Sanders page 8

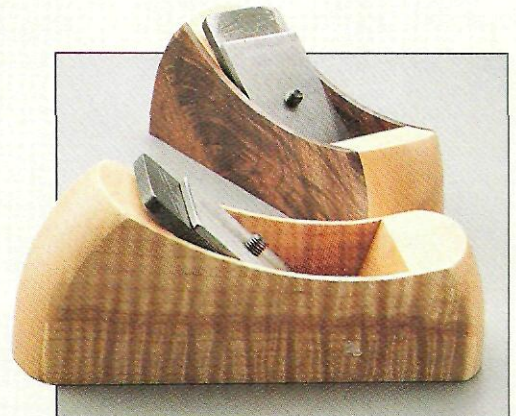

Hand Plane page 10

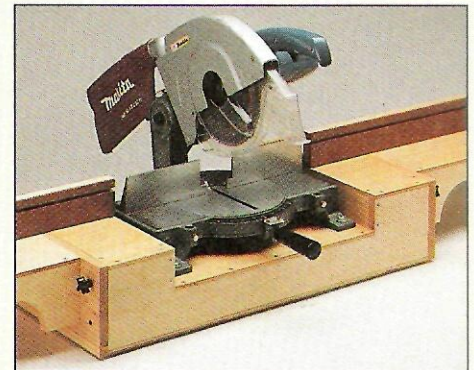

Miter Saw Station page 16

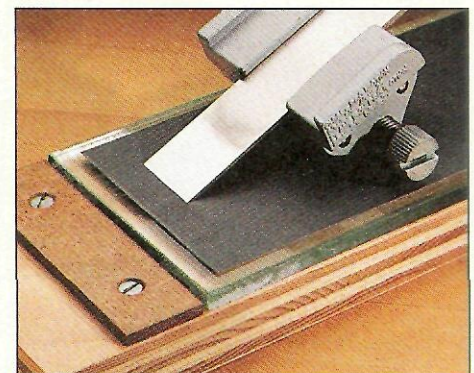

Sharpening page 24

# Drill Press Table Counterweight

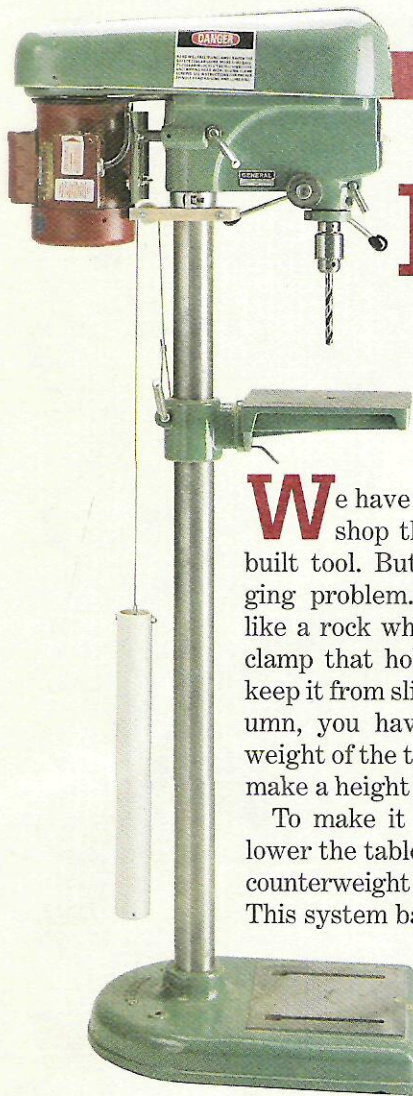

**W**e have a drill press in the shop that's a solid, well-built tool. But there's one nagging problem. The table drops like a rock when you loosen the clamp that holds it in place. To keep it from sliding down the column, you have to support the weight of the table each time you make a height adjustment.

To make it easy to raise and lower the table, I added a simple counterweight system, see photo. This system balances the weight of the table so a small amount of fingertip pressure is enough to position it at the desired height.

*A counterweight system makes it easy to raise and lower the table on a drill press.*

**COLLAR.** Once I'd settled on the idea of using a counterweight, the challenge was figuring out a way to attach it to the drill press. To do this, I added a wood "collar" at the top of the column.

The collar is a piece of  $\frac{3}{4}$ "-thick stock that fits around the column, see Fig. 1. It supports a pulley that allows the counterweight to travel smoothly up and down as you adjust the table height. (The pulley is just a plastic wheel for a sliding glass door that I picked up at the local hardware store.)

With the pulley in hand, the next step is to size the collar (A) so it fits under the head of the drill press. The width of the collar is 5", see Fig. 2a. But the length may vary depending on your motor and mounting brackets. (In my case, this was 7".)

**LAYOUT HOLE.** After cutting the collar to length, you can lay

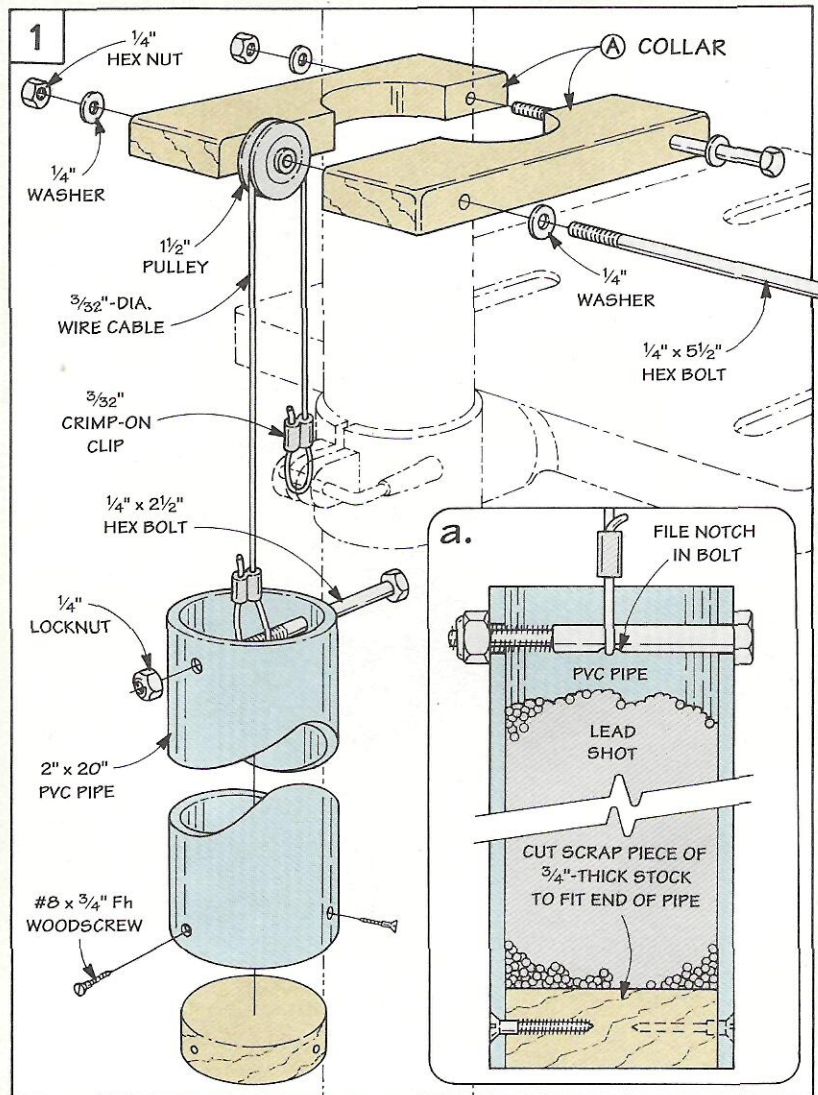

## Hardware

- (2)  $\frac{1}{4}$ " x  $5\frac{1}{2}$ " Hex Bolts
- (4)  $\frac{1}{4}$ " Washers
- (2)  $\frac{1}{4}$ " Hex Nuts
- (1)  $\frac{1}{2}$ " Sliding Glass Door Wheel (for Pulley)
- (1)  $\frac{1}{4}$ " x  $2\frac{1}{2}$ " Hex Bolt
- (1)  $\frac{1}{4}$ " Lock Nut
- (2)  $\frac{3}{32}$ " Crimp-On Clips
- $\frac{3}{32}$ "-Dia. Wire Cable (4 ft.)
- (1) 2" x 20" PVC Pipe
- (3) #8 x  $\frac{3}{4}$ " Fh Woodscrews
- Lead Shot to Match Weight of Drill Press Table

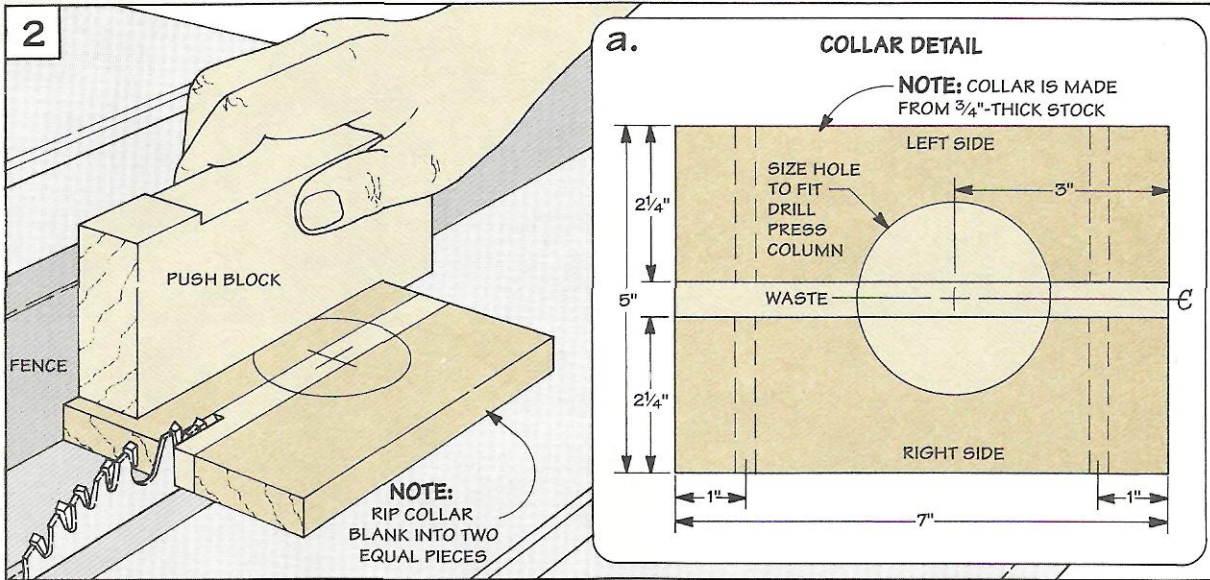

Use a C-clamp to measure the diameter of the drill press column.

out the hole for the drill press column. To do this, measure the diameter of the column and transfer a circle of this size to the collar, see tip in margin and Fig. 2a.

To avoid binding the pulley when the collar is tightened, I ripped a 1/2"-wide "clearance" strip down the center, see Fig. 2. Then it's just a matter of cutting the curved openings for the column.

The collar is held together with bolts. The trick is to align the holes for the bolts in both pieces. To do this, I clamped a fence and stop to the drill press table, and then drilled the holes, see Figs. 3 and 4.

**ATTACH COLLAR.** The next step is to attach the collar by bolting the two halves together with the pulley in between. Tightening hex nuts on the ends of the bolts locks the collar in place.

**COUNTERWEIGHT.** Now you can add the counterweight. To raise and lower the table without exerting a lot of pressure, it needs to be roughly equal to the weight of the table.

What you use for a weight isn't critical. The important thing is it's compact enough so it doesn't bump into the column. I used a length of 2" PVC pipe filled with lead shot, refer to Fig. 1a. To hold the shot, a scrap piece of wood is

cut to fit inside the bottom of the pipe and screwed in place.

**WIRE CABLE.** All that's left is to connect the counterweight to the table by running a wire cable over the pulley. I slipped one end between the column and the table clamp, and used a crimp-on clip to

form a loop, see Fig. 5.

To attach the other end to the counterweight, a bolt is passed through a hole in the pipe and another loop in the cable. Note: Filing a notch in the bolt keeps the wire from sliding side to side, refer to Fig. 1a.

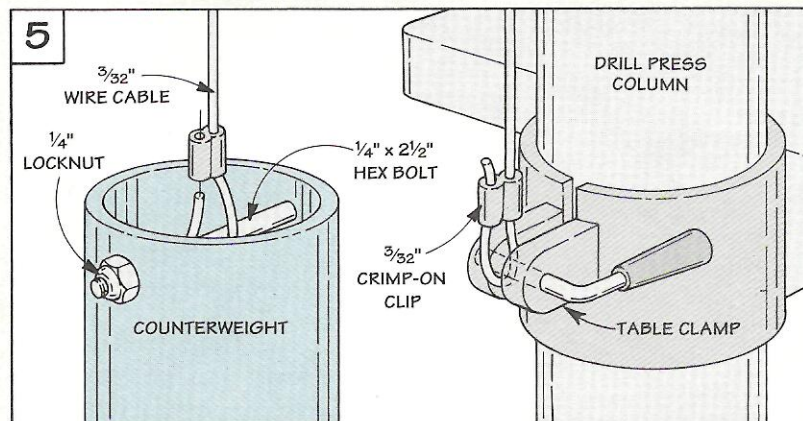
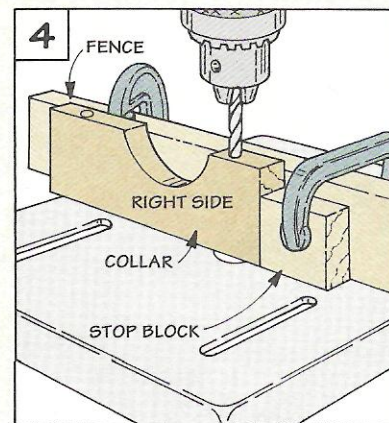
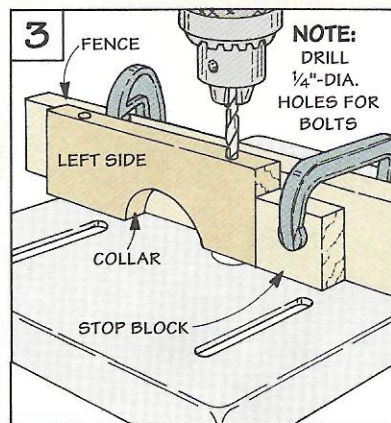

# Pipe Clamp Rack

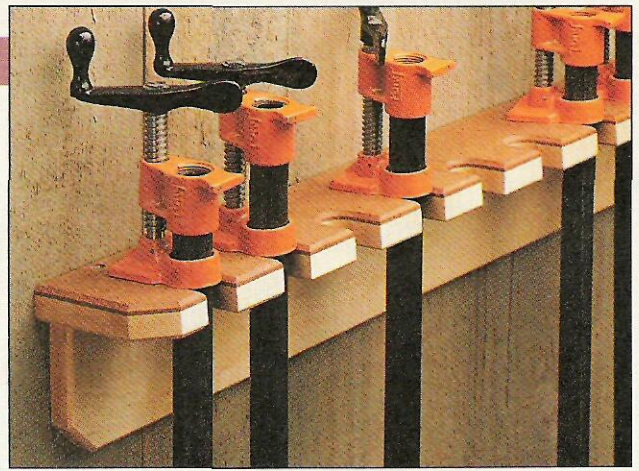

*An easy to build rack that organizes your pipe clamps and keeps them right at hand.*

**P**ipe clamps are one of those tools that when you need them, nothing else will do. But when they're not being used, where do you store them?

One solution is this Clamp Rack, see photo. It mounts to the wall to organize your clamps and keep them right at hand.

**TOP.** To provide a "shelf" for the clamps, I started by making the top (A). Each clamp fits in a notch cut in the front edge. The only problem with this is there's no support for the short sections between the notches. And with use, heavy clamps can break these off.

To strengthen the top, I glued a strip of Masonite to a piece of

$\frac{3}{4}$ "-thick hardwood, see Fig. 1. Next, to prevent clamps from slipping out of the rack, the top is tilted at a slight angle. To allow it to fit tight against the wall, the back edge is beveled, see Fig. 1a.

**NOTCHES.** There are two things to consider when you're ready to cut the notches: the diameter of the pipe, and size of the clamp heads. In order for the clamps to slide easily in and out of the rack, the notches are sized  $\frac{1}{8}$ " larger than the diameter of the pipe. (In my case, this is  $1\frac{1}{8}$ ".)

It's also important to space the notches far enough apart to prevent the clamp heads from hitting each other. For my  $\frac{3}{4}$ " pipe

clamps, I spaced the notches 3" apart, see Fig. 1b.

After the notches are cut, there's one more thing to do. To prevent the edges from splintering when sliding clamps in and out, I routed a slight chamfer on both faces of the top (A), see Fig. 1a.

**BACK.** With the top complete, the next step is to make the back (B). To tilt the top slightly, the top edge is beveled at a  $5^\circ$  angle, see Fig. 1a. Then the top and back are glued and screwed together.

**MOUNT RACK.** All that's left is to mount the rack in a handy location. Because of the weight of the clamps, I used lag screws and fastened them into wall studs.

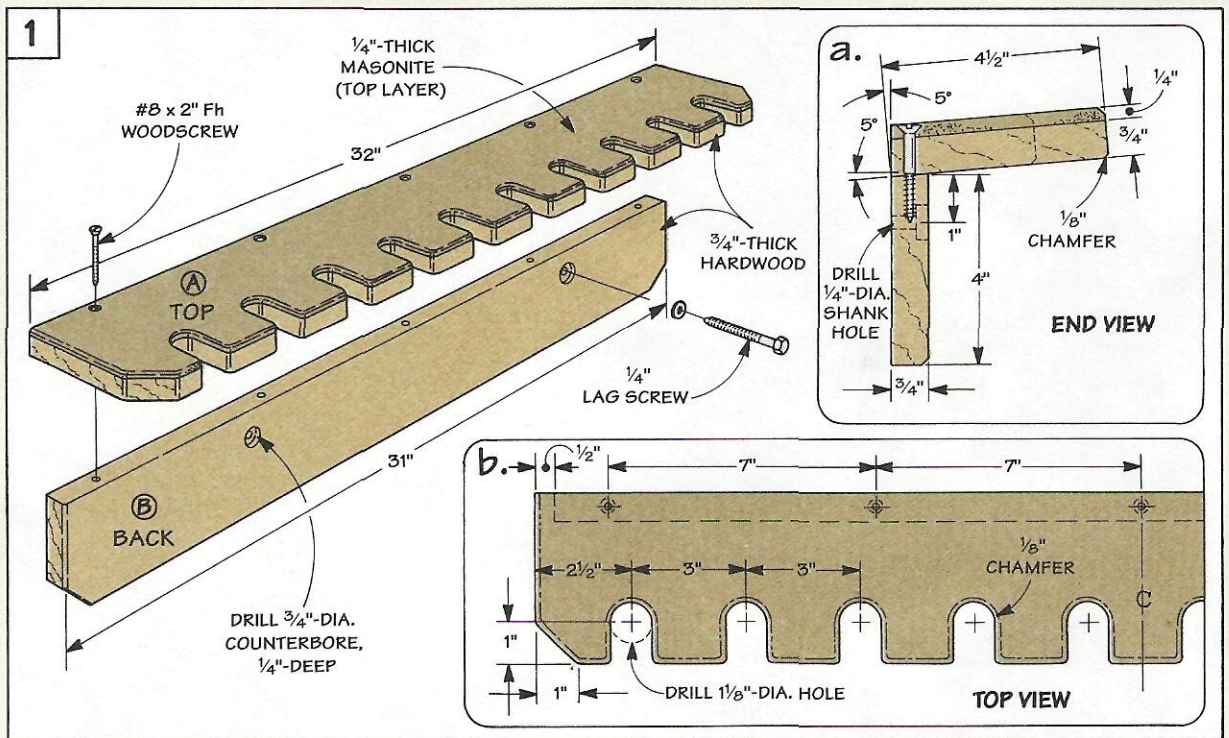

# Radial Arm Saw Return

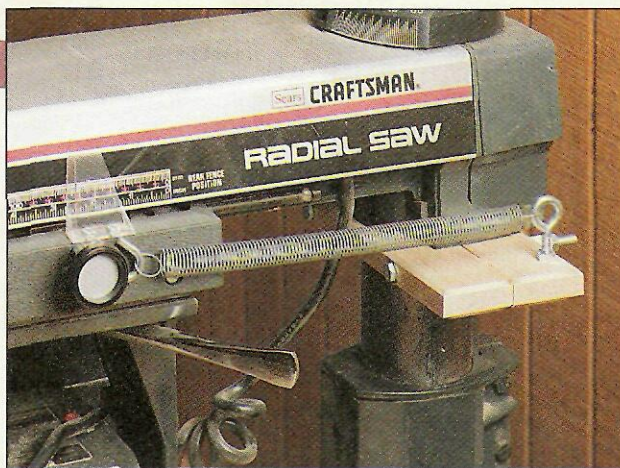

One thing I've noticed about the blade on my radial arm saw is it has a tendency to creep forward when the saw is running.

The thought of the blade accidentally catching the edge of a workpiece and "walking" across the top is downright scary. So I built a simple return to hold the blade in *back* of the fence until I'm ready to make a cut.

**SPRING.** What makes the return work is a spring that attaches to the column of the saw and the carriage, see Fig. 1. The spring

keeps the blade from inching forward. As you pull the blade toward you to make a cut, the tension that's produced draws the blade back to its starting point.

The trick is to get a spring that's strong enough to return the blade, yet not so stiff it's hard to pull. To do this, I measured the *total* travel of the blade. (In my case, this was 17".) Then I bought a spring at the hardware store that extended easily to this distance.

**COLLAR.** To anchor the spring, I added a *collar* (A) to the column

of the saw, see Fig. 2. The collar starts out as a  $\frac{3}{4}$ "-thick piece of hardwood (I used maple).

To fit it to the saw, you'll need to measure the diameter of the column and mark a circle of this size on the collar, see detail in Fig. 2. Then, after ripping it down the center, the curved openings can be cut. Before attaching the collar, I drilled a hole for an eye bolt that secures one end of the spring.

**ATTACH COLLAR.** The collar is held together with bolts. (For a tip on aligning and drilling the holes for these bolts, refer to Figs. 3 and 4 on page 5.) Next, pinch the collar tight around the column by installing the bolts and tightening nuts on the ends.

**INSTALL HARDWARE.** To complete the return, I attached the eye bolt with two hex nuts. One end of the spring is attached to the "eye", and the other to an S-hook which fits over the knob that locks the blade in the rip position.

*Make your radial arm saw safer to use with a scrap of wood and a few pieces of hardware.*

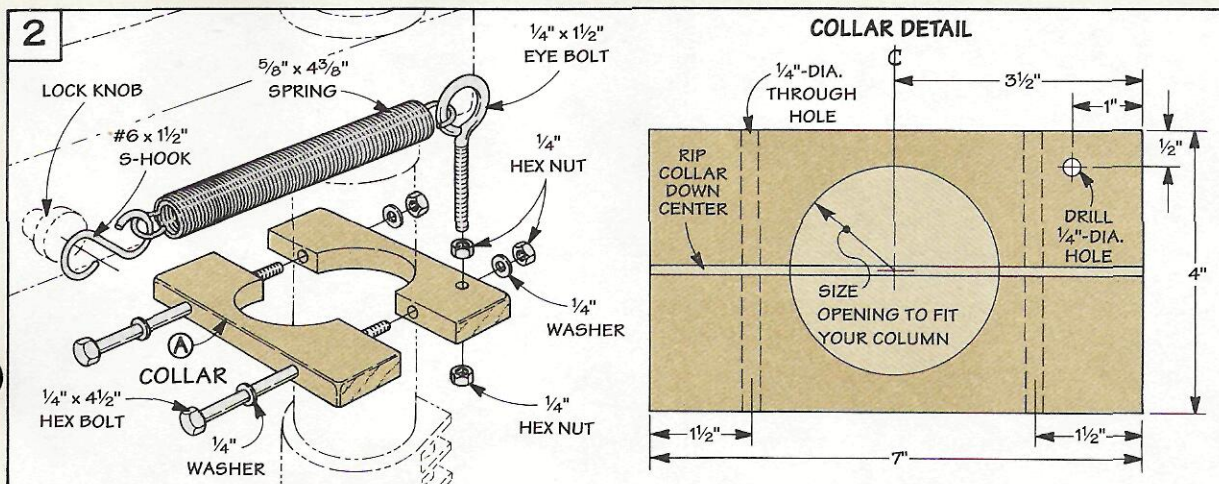
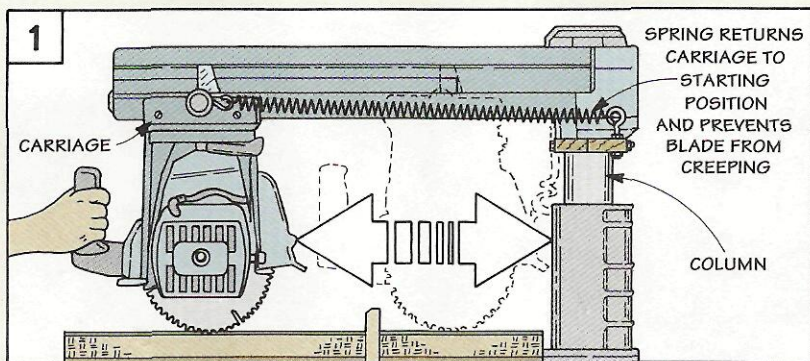

- ### Hardware
- (2)  $\frac{1}{4}$ " x  $\frac{1}{2}$ " Hex Bolts
  - (4)  $\frac{1}{4}$ " Washers
  - (4)  $\frac{1}{4}$ " Hex Nuts
  - (1)  $\frac{1}{4}$ " x  $\frac{1}{2}$ " Eye Bolt
  - (1)  $\frac{5}{8}$ " x  $4\frac{3}{8}$ " Spring
  - (1) #6 x  $\frac{1}{2}$ " S-Hook

# Random-Orbit Sanders

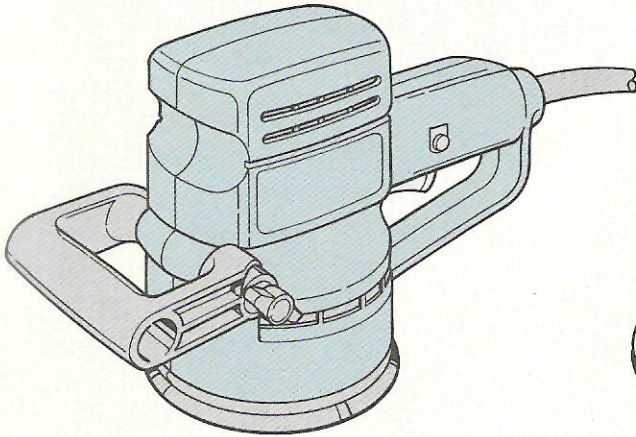

**PISTOL-GRIP**

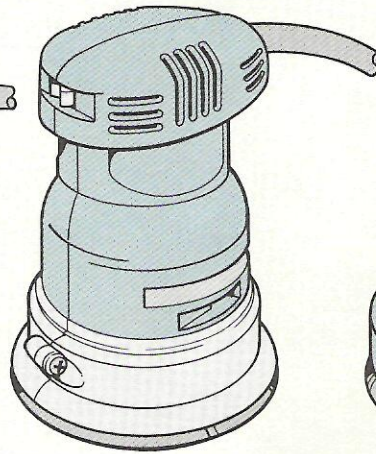

**PALM-GRIP**

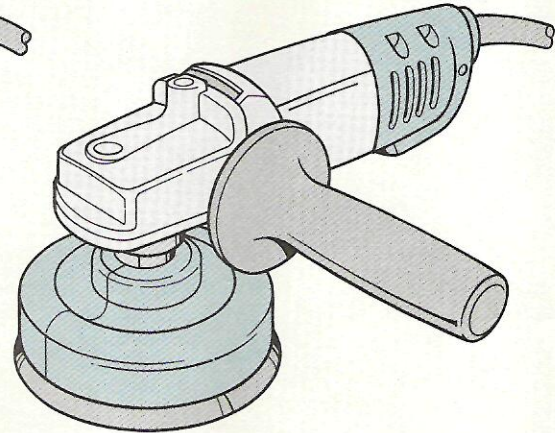

**RIGHT-ANGLE**

*Random-orbit sanders remove stock quickly without creating cross-grain scratches.*

**W**hen random-orbit sanders first appeared in the woodworking catalogs a few years back, I was a bit skeptical. Did I really need another sander? After all, I've built a lot of projects with just a belt and finish sander.

Eventually, I gave in to curiosity and bought one. And I'm glad I did. The random-orbit sander removed material a lot faster than my finish sander. And unlike my belt sander, I could sand in any direction without creating cross-grain scratches.

**DRIVE SYSTEM.** So how can a random-orbit sander do all this? It has to do with the drive system.

A shaft rotates a counter-weighted disk. This disk carries an off-center bearing. And attached to the bearing is a pad that holds sandpaper. In operation, the offset between the shaft and disk creates both rotary and orbital motions, see Drawing at right.

The amount of offset ranges from  $\frac{3}{32}$ " to  $\frac{5}{32}$ " depending on the manufacturer. Generally, larger offsets offer a more aggressive

sanding action — but can be more difficult to control.

### THREE STYLES

Although the motion of all random-orbit sanders is similar, there are three distinct styles: pistol-grip, palm-grip, and right-angle.

**PISTOL GRIP.** Pistol-grip sanders (also called in-line) have their motors *directly* above the sanding disk, see Drawing above. Since the drive motion is transferred directly to the disk, these sanders are very quiet. And the "pistol" style grip makes these sanders the easiest to control — even with one hand.

But putting the motor above the disk does have its drawbacks. A tall motor housing makes it difficult to sand inside cramped cabinets or drawers. There's also a tendency to tip or tilt during sanding which can cause the disk to gouge the workpiece.

**PALM-GRIP.** Palm-grip random-orbit sanders most closely resem-

ble a finish sander, see above. They're small, lightweight, and intended for one-handed use. But as with the pistol-grip style (where the motor is above the disk), these sanders are tall and have a tendency to tilt.

**RIGHT-ANGLE.** The right-angle style sander is basically a right-angle grinder with a random-orbit head, see above.

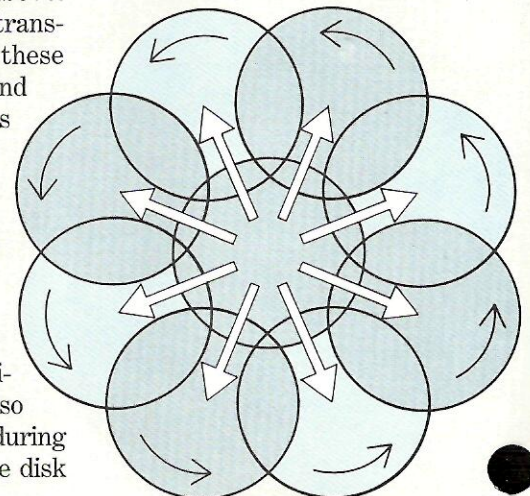

**NOTE: RANDOM OFFSET EXAGGERATED FOR CLARITY**



Though noisy, these sanders generally have large, powerful motors. Which makes them very aggressive — almost like a belt sander. This means they take off stock quickly and are excellent for rough shaping and sanding.

The only drawback to this aggressive sanding style is it makes a right-angle sander harder to control. For best results, I always use two hands. One on the body, and the other on the bicycle-style grip that comes with the sander.

### SANDPAPER OPTIONS

In addition to the different styles, there are also a couple of options for attaching sandpaper to the pad: pressure sensitive adhesive (PSA), and hook and loop (hook and loop is similar to *Velcro*).

**PSA.** A disk backed with a pressure-sensitive adhesive is the

simplest method of attaching sandpaper; see photo at right. Just press the disk on the pad and start sanding. Since the disk is stuck directly to the pad, I've found I get better feedback when sanding — it's easier to "feel" the surface I'm sanding. And when it's worn out, peel it off and throw it away.

**HOOK & LOOP.** With the hook and loop system, disks can be removed and remounted many times, see photo at right. In addition to this, there's another advantage.

A wide range of optional disks are also available (such as buffing and polishing pads). You can even stick a piece of *Scotch-Brite* directly on the disk (or a felt pad) and do some nice finish sanding.

The only disadvantage to hook and loop is (depending on the source), the disks may cost you more than PSA.

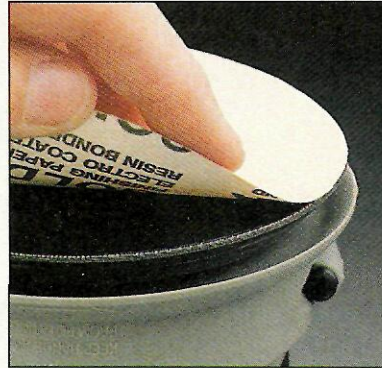

◀ **PSA.** Pressure sensitive adhesive backed disks provide the best "feel" of the work surface. And when the disk wears out, just peel it off and throw it away.

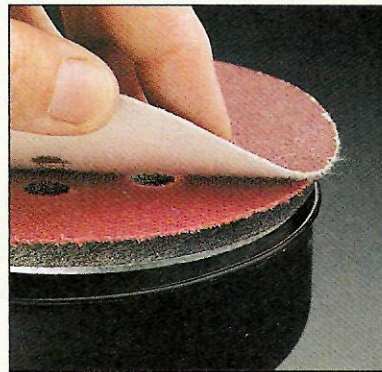

◀ **Hook & Loop.** Sanding disks that attach with the hook and loop system can be removed and remounted many times to increase the life of the disk.

## Sanding Techniques

The first time I used a random-orbit sander the sanding disk skipped over the work surface like a flat stone on a calm pond. I was sure there was something wrong. But there wasn't. The random orbit motion just takes some getting used to.

**START-UP.** The first noticeable difference is how you start up. To reduce the chance of gouging the work when the disk first makes contact, these sanders are best started while *in contact* with the workpiece.

And you should always start the sander with the disk flat, and in *full contact* with the surface (and keep it that way).

**PRESSURE.** Another peculiarity of these sanders is they don't respond to pressure like other sanders where additional pressure results in a more aggressive sanding action.

When you press down on a

random-orbit sander (particularly the pistol and palm-grip styles), you decrease the sanding action. Additional pressure actually slows down the free-wheeling disk and results in *less* sanding. I've found that light to moderate pressure produces the best results.

**LIFT OFF.** When you're finished sanding, some manufacturers suggest you let the sander stop on the workpiece. But I've noticed the disk hops around when I do this and scratches the surface. So instead, I turn the sander off and lift it *straight* up and off.

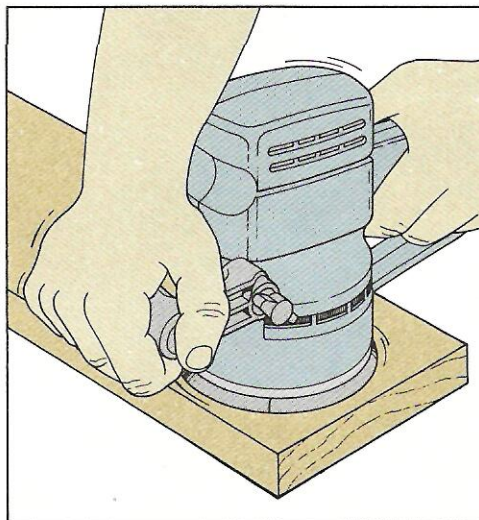

**Step 1: Start-Up.**

Place sander on surface with disk flat and turn it on.

**Step 2: Sanding.**

As you sand, keep disk flat and use even pressure.

**Step 3: Finished.**

Lift sander up to prevent disk from gouging surface.

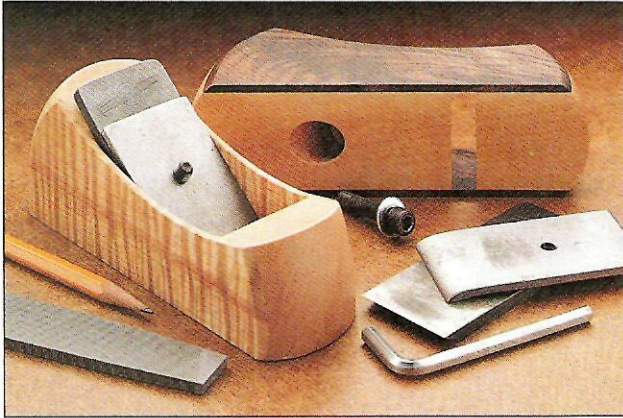

# Hand Plane

*A simple design and a unique method of securing the blade make building this plane an easy alternative to a traditional wood plane.*

**T**here's no question about it. I have an incurable weakness when it comes to hand planes — especially wood planes. There's just something special about the look and "feel" of a wood-bodied plane.

The problem is making a traditional wood plane and fitting the blade correctly can be time consuming work.

So we designed a small hand plane that combines the look and feel of a wood plane with a simple, straightforward method for holding the blade, see photo. The result of all this is you can build the plane in the morning and be making shavings in the afternoon.

**BLADE.** I started with a 1½"-wide blade manufactured by the Hock Company. As with other Hock blades I've used, it's made of high quality steel and holds an edge extremely well. Like most bench plane blades, it comes with a cap iron as part of a matched set. (For sources, see page 31.)

But even a good blade won't work well unless it's sharp. So I took a few minutes to get a nice, sharp edge. (For more on sharpening, see page 24.)

**CORE.** After sharpening the blade, I started work on the core of the plane. It consists of two wedge-shaped blocks, see Exploded View. When the sides are added later, the blade fits in the opening created by the two blocks.

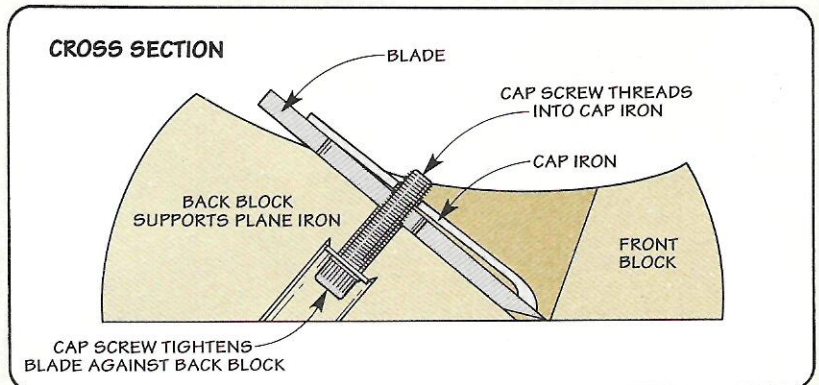
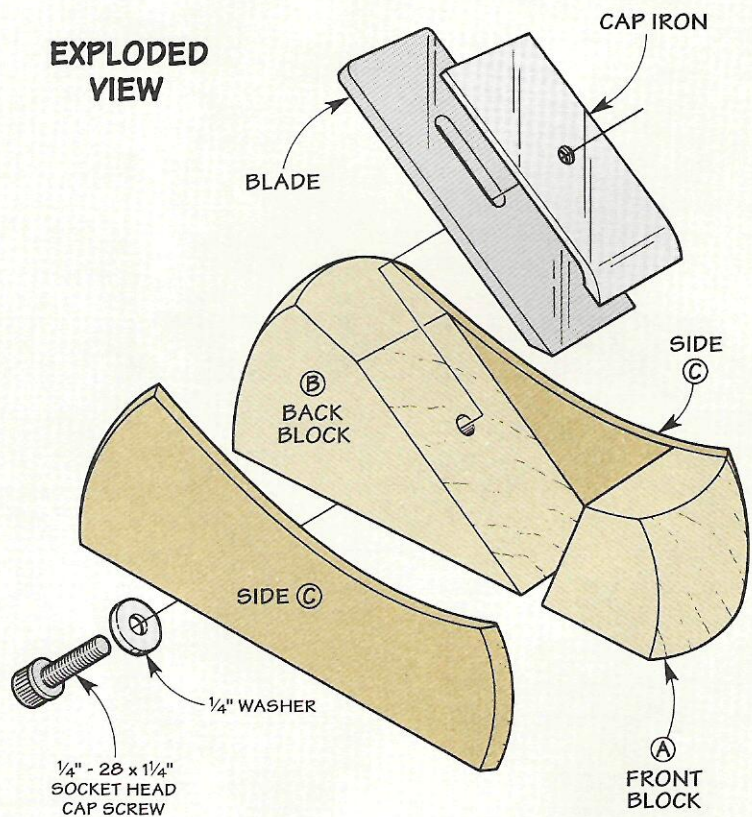

Both blocks start out as a single hardwood blank, see Fig. 1. (I used a piece of hard maple.) The thickness of this blank determines the width of the opening for the blade. To allow for some side to side blade adjustment, the blank is  $\frac{1}{16}$ " thicker ( $\frac{19}{16}$ " ) than the width of the blade ( $1\frac{1}{2}$ " ).

**CUT BLOCKS.** To provide room inside the plane for the shavings, the *front block* (A) is cut at a  $70^\circ$  angle, see Figs. 1 and 2. The angle of the *back block* (B) determines the cutting angle of the blade. For all-around use, I cut it at a  $40^\circ$  angle, and then trimmed the block to length, see Figs. 1 and 2.

**MOUNTING SYSTEM**

The next step is to provide a way to mount the blade. This is where I took a slight detour from the traditional approach. Instead of a wood wedge that exerts pressure from *above*, the blade is "screwed" to the back block from *below*.

The secret is a socket head cap screw. It passes through a hole in the back block, and into the threaded hole in the cap iron, see Cross Section on page 10. Tightening the screw draws the cap iron tight against the blade and locks it in place.

**EXIT HOLE.** In addition to securing the blade with a screw, the procedure for locating the hole is

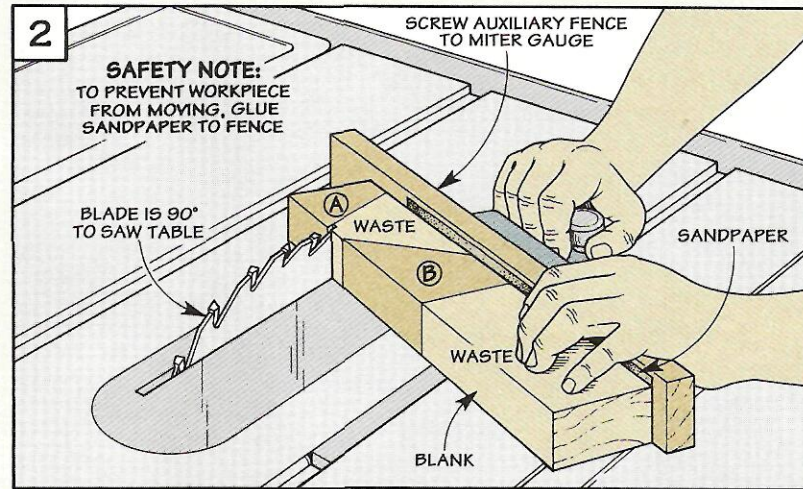
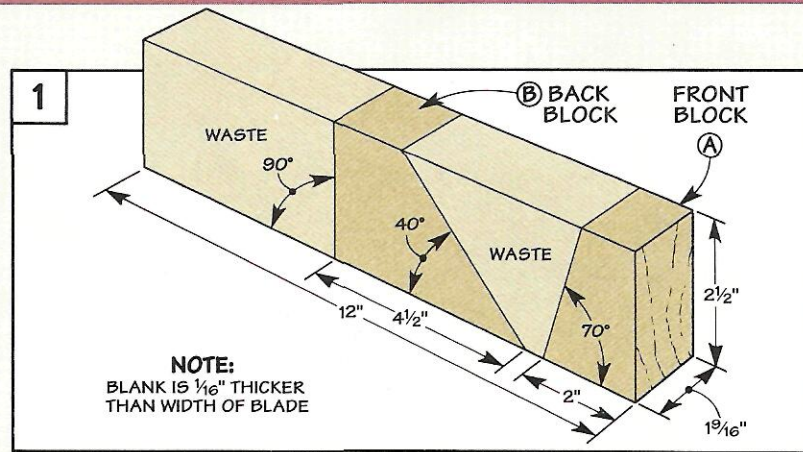

also a bit unusual. The first step is to find the point where the drill bit will *exit*. To do this, position the cap iron so the tip is located just *behind* the cutting edge, see Fig. 3. Then mark the location of the hole with a brad point bit.

Once the exit point is established, the trick is knowing where

to *start* drilling in the bottom of the block. This depends on the distance from the tip of the block to the mark. The idea is to clamp a fence this same distance away from the centerpoint of a bit, see Fig. 4. Then, with the tip of the block against the fence, drill a counterbored shank hole.

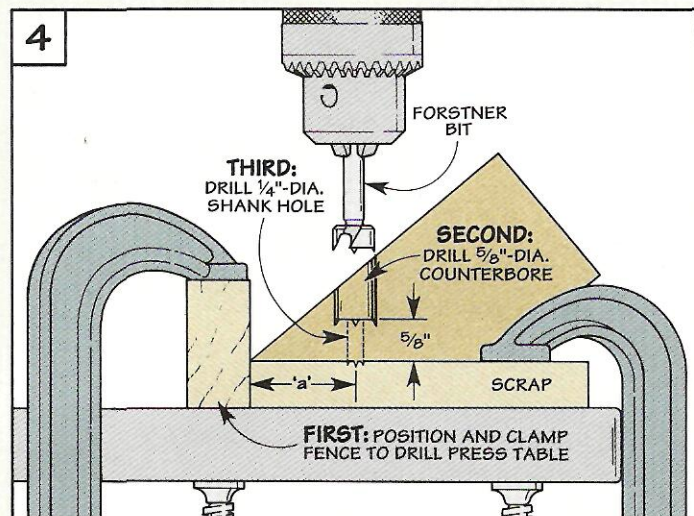
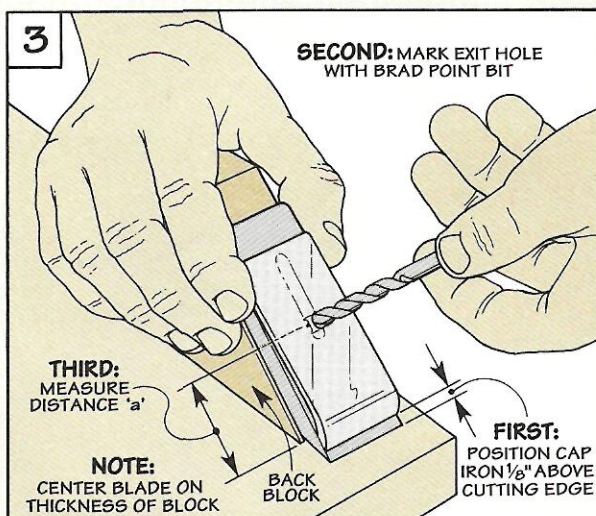

## The Sides

After completing the core, work can begin on the sides of the plane. The sides are just thin strips of hardwood that hold the front and back blocks together.

Although any hardwood would work here, it's a perfect opportunity to experiment with an unusual or highly figured piece of wood. I chose a piece of curly maple for the sides. We also built another plane with sides made of walnut, refer to photo on page 10.

Regardless of the wood you use, each *side* (C) starts out as an  $\frac{1}{8}$ "-thick blank that's cut to a rough length of 7", see Fig. 5. Attaching these blanks to the front and back blocks does two things. First, it creates the opening for the blade. Second, it forms the sole (bottom) of the plane.

**SOLE.** The sole keeps the blade a consistent distance from the workpiece. So in order to produce an even cut, it needs to be as flat as possible. To ensure that it's flat, I used the top of my table saw to align the bottom edges of the sides and blocks, see Fig. 6. Note: A piece of wax paper protects the top from glue squeeze-out.

### ASSEMBLY

To avoid having to align all the parts at once, I assembled the plane one block at a time. This

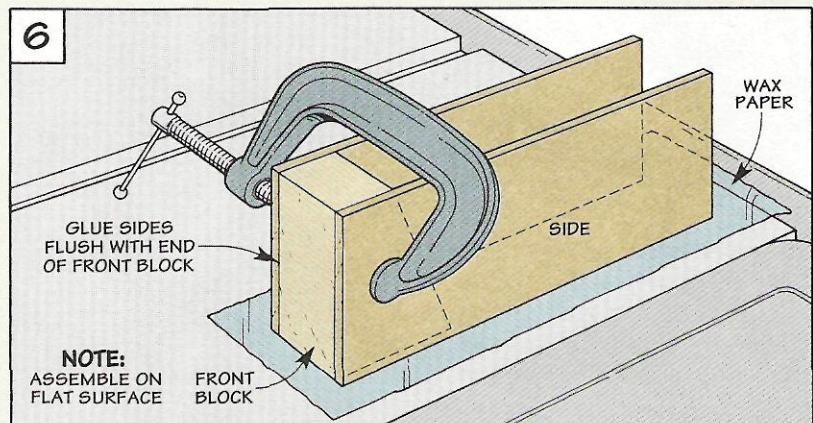
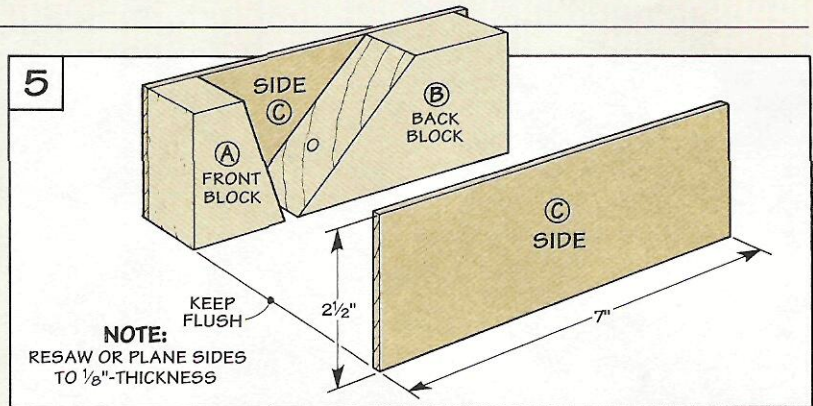

makes it easier to check that the sides are straight and square.

**FRONT BLOCK.** I attached the front block (A) first. After applying glue to the sides of the block, it's just a matter of clamping the sides (C) around it so they're flush at the end, see Fig. 6.

**THROAT OPENING.** When the glue dries, you're ready to add the back block (B). The position of

this block creates an opening or "throat" in the sole of the plane for the blade, see Fig. 7a. The idea is to make this opening large enough so shavings don't clog it up. Yet small enough to produce a clean cut.

**SET OPENING.** An easy way to establish this opening is to use the blade as a "gauge." To do this, temporarily install the blade so the cut-

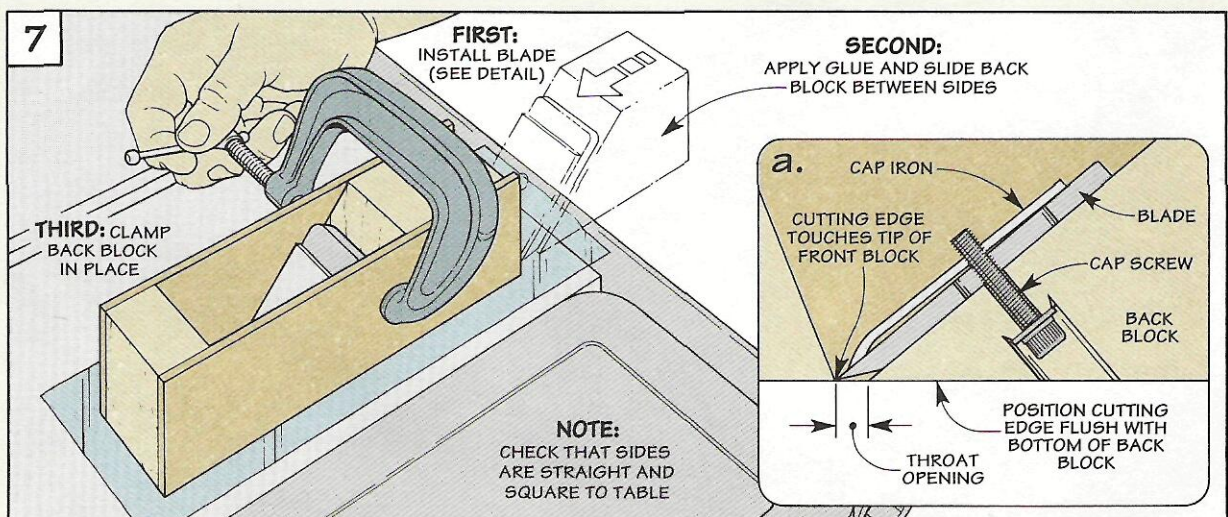

## FULL-SIZE PATTERN

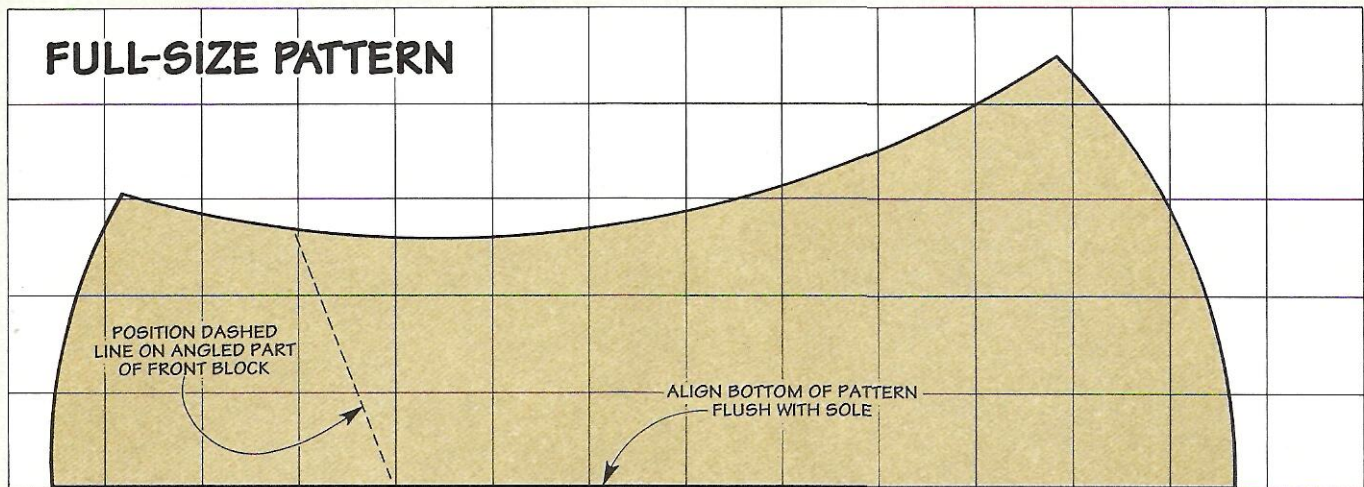

ting edge is flush with the bottom of the back block, see Fig. 7a.

To attach the back block (B), apply glue to the sides of the block. Then spread the sides (C) apart just a bit as you slide the block forward, see Fig. 7.

When the cutting edge touches the tip of the front block, clamp the block in place. Then remove the blade, and clean up any glue that squeezed out.

## SHAPING THE PLANE

With the sides in place, the next step is to shape the body of the plane. I experimented with several different shapes to find the most comfortable grip.

The one I liked best has a rounded back that fits in the palm of my hand. And the gentle curve on the top of the plane lets me apply pressure without having my finger slip off the front block, see Full-Size Pattern above.

*Editor's Note:* You may prefer to customize your own shape. But if you want to use the pattern shown above without cutting it out of the issue, you can reproduce it on a photocopy machine.

**PATTERN.** To position the pattern on the side of the plane, there's a dashed line representing the angled part of the front block. The pattern can be attached to the side of the plane with either a spray-on adhesive (like 3M's Spray Mount) or rubber cement.

**CUT TO SHAPE.** With the pattern in place, the plane is ready to cut to *rough* shape. Start by cutting to within  $\frac{1}{16}$ " of the line on the band saw, see Fig. 8. Then use the drum sander on the drill press to sand up to the line.

**CROWN.** There's just one more thing to do to complete the basic shape. That's to file the sharp corners off both ends of the plane to

form a gradual crown, see Crown Detail below. To raise the plane to a comfortable working height, I clamped it in a handscrew that's tightened in a vise, see Fig. 9.

**SAND SMOOTH.** All that's left to do is to sand the plane smooth. An easy way to sand the ends is to use a strip of sandpaper and "buff" the plane as if you're shining a pair of shoes, see Fig. 10.

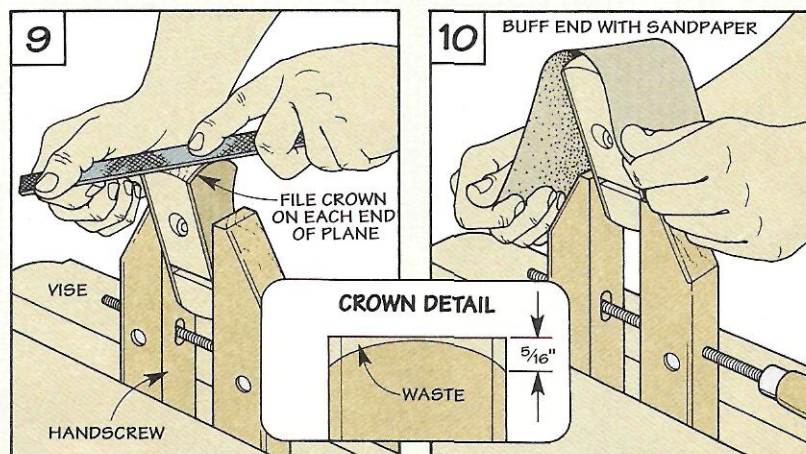
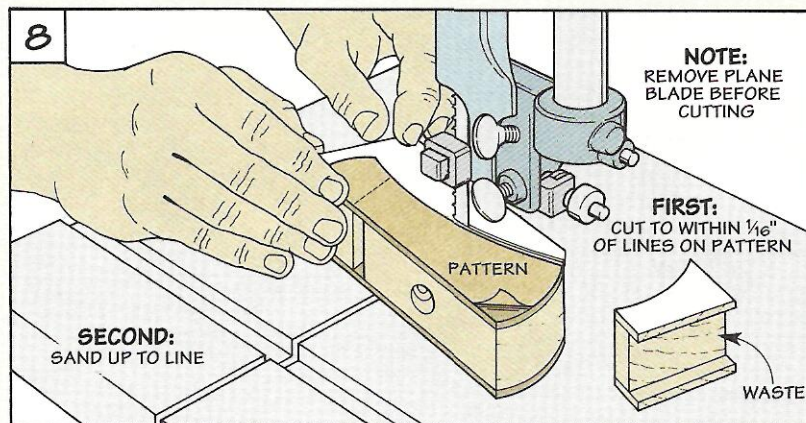

# Tuning Up the Plane

Like any plane (wood or metal), this hand plane needs to be tuned up before you can use it. This takes a little patience. But the satisfaction you'll get seeing thin shavings curl off a workpiece is worth the effort.

## TRUE THE SOLE

The key to this tune-up is to "true" the sole (bottom) of the plane so it's good and flat. This does two things.

First, it ensures that the plane rides evenly across a workpiece, so you end up with a smooth, consistent cut. Second, it enlarges the throat opening for the blade.

**SAND BOTTOM.** To flatten the sole, I place a piece of fine grit sandpaper on a flat surface (like a saw table). Note: To prevent the plane from rocking, clamp a board 90° to the saw table, see Fig. 11.

Now it's simply a matter of

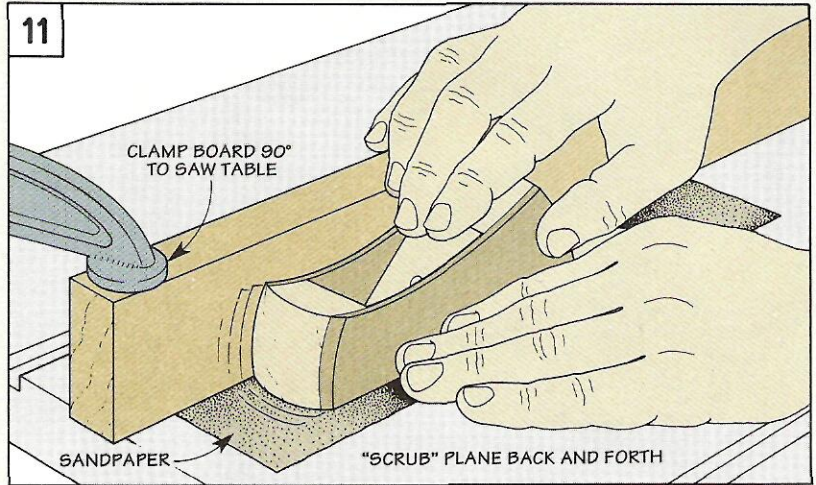

"scrubbing" the plane back and forth across the sandpaper. To avoid sanding too much (and opening up the throat too far), it's a good idea to check your progress frequently.

**CHECK OPENING.** The idea is to make the throat opening just large enough so shavings don't

clog up the plane. To check this, install the blade so the cutting edge is flush with the sole, see Fig. 12. What you're looking for here is a  $\frac{1}{16}$ " gap between the tip of the front block and the blade, see Fig. 12a. If the gap isn't wide enough, remove the blade and continue sanding.

**SQUARE OPENING.** Once the throat opening is established, there's just one more thing to check. That's to see if the front edge of the opening is square to the sides, see Fig. 13. If it's not square, remove the blade and carefully make a few *light* passes with a file, see Fig. 14.

**FINISH.** Finally, to complete the plane and protect the surface from getting dirty, I applied a couple of coats of an oil finish.

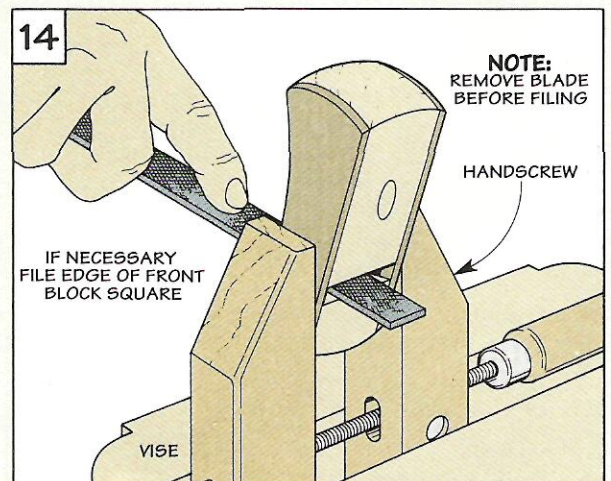
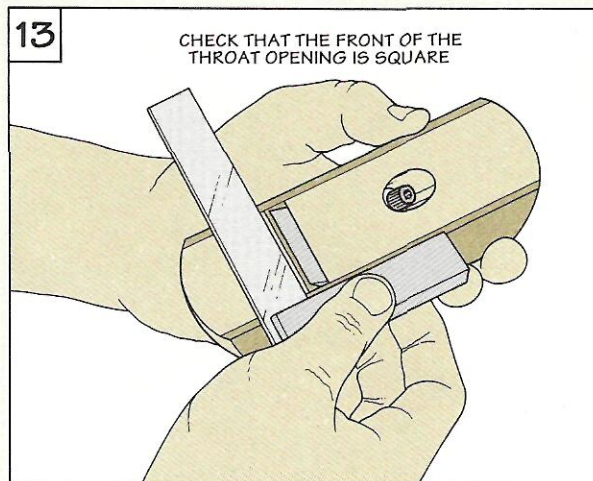
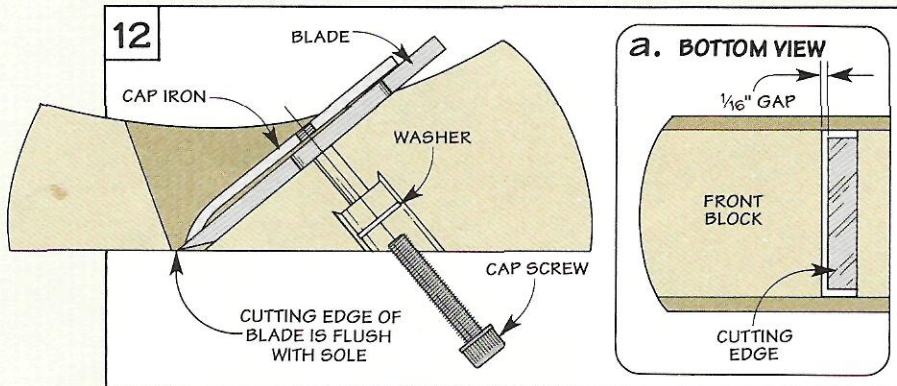

## Adjusting the Blade

As with any plane, the secret to getting paper-thin shavings is to use a sharp blade, and adjust it so the cutting edge is just a whisker below the sole of the plane.

I start by roughly positioning the blade, see Step 1. To hold it in place, the cap screw is tightened with an Allen wrench so the blade is snug, see photo.

**FINE TUNING.** Before fine tuning the blade, I make a trial cut. Depending on the thickness of the shaving, the blade can be raised (or lowered) by tapping the plane

with a mallet. Note: To avoid damaging the plane, use either a wood or a *No-Mar* mallet.

To make a shallower cut, tap the back of the plane to move the blade back, see Step 2. Tapping the front of the plane moves the blade forward for a deeper cut.

**SQUARE BLADE.** If you need to square the blade, the process is slightly different. The “high” corner of the blade is dropped into the cutting position by tapping on the opposite side of the plane, see Step 3.



The blade is held in place by tightening the socket head cap screw with an Allen wrench.

### Step 1: Position the Blade.

The blade is positioned so the cutting edge is flush with the sole. Then the cap screw is tightened with an Allen wrench until the blade is snug. This pulls the cutting edge down just below the sole of the plane.

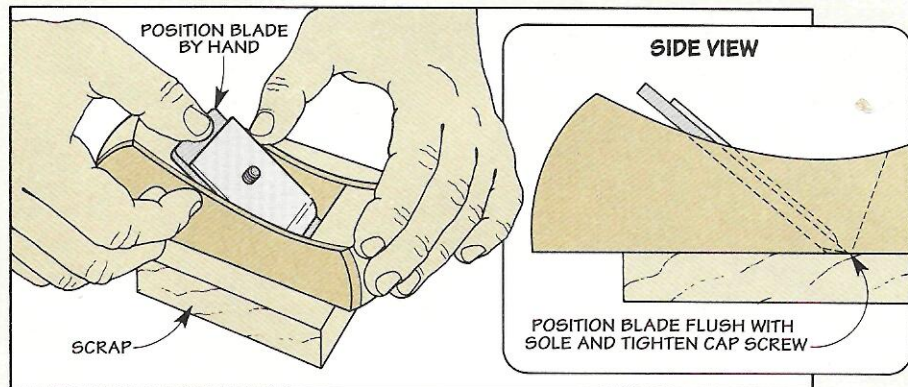

### Step 2: Adjust Depth of Cut.

After making a trial cut, you may need to adjust the depth of cut. To make a shallower cut, tap on the back of the plane with a mallet. To make a deeper cut, tap the front of the plane.

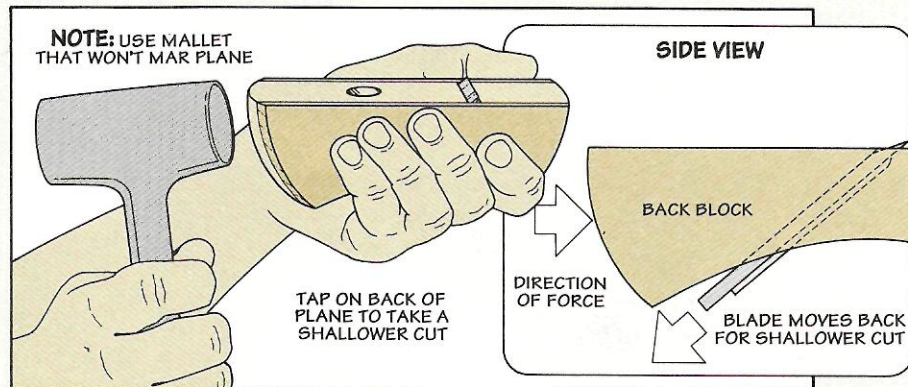

### Step 3: Square the Blade.

To maintain a consistent depth of cut across the width of the blade, the cutting edge should be parallel with the sole. Striking the opposite side of the “high” corner drops the blade into the cutting position.

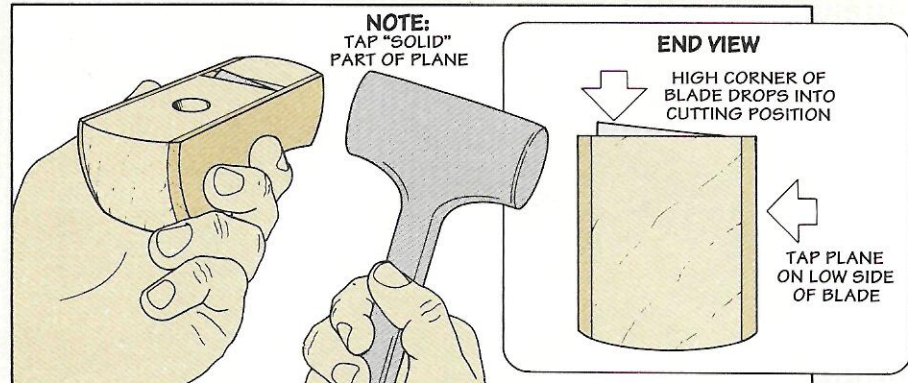

# Portable Miter Saw Station

*The unique design of this work station makes your miter saw safer and more accurate to use.*

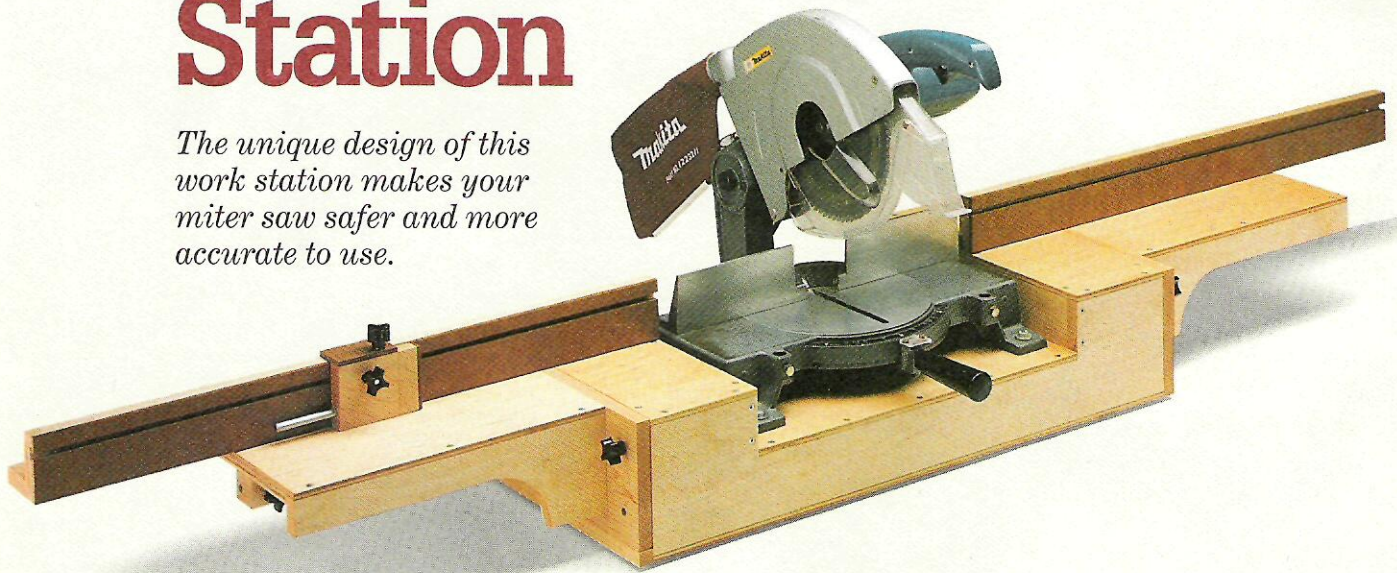

**W**here's the power miter saw? It's one of the most often asked questions in our shop. That's because the miter saw is one shop tool that's never in the shop. Someone has always borrowed it to use at home. What else would you expect with a power tool that's both accurate *and* portable?

And every time the miter saw comes back into the workshop, there's always talk about building a work station for it. Something that would support long stock. And some sort of a stop system for making accurate repeat cuts.

The challenge was to incorporate all these ideas without sacrificing portability. Our answer is this Miter Saw Station, see photo above.

**EXTENSION WINGS.** To support long workpieces, we designed a pair of extension wings that attach to the ends of the station. For portability, these wings can be "tucked" away inside the case, see photo A. And when stored, the wings provide built-in handles to make it easy to lift and move the miter saw, see photo B.

**FENCE SYSTEM.** One problem with most miter saws is they have short fences. And this makes it difficult to position a long workpiece for an accurate cut. To solve this, we added a pair of rails to extend the fences, see photo above. And for accurate repeat cuts, there's even a stop system that slides in slots cut in the fence rails, see photo C.

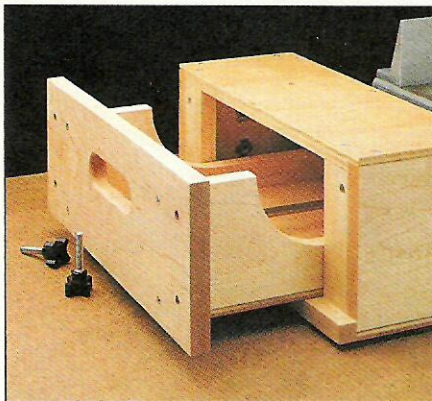

**A. Wings:** A pair of wings offer support to long stock and then "tuck" away inside the case for storage.

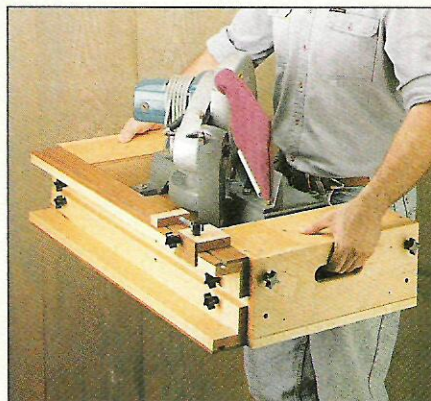

**B. Portable:** To make it easy to lift and carry the miter saw station, the wings have built-in handles.

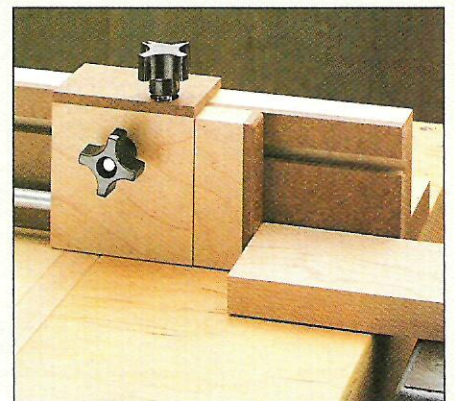

**C. Stop System:** For accurate repeat cuts, an adjustable stop slides in slots cut in the fence rails.



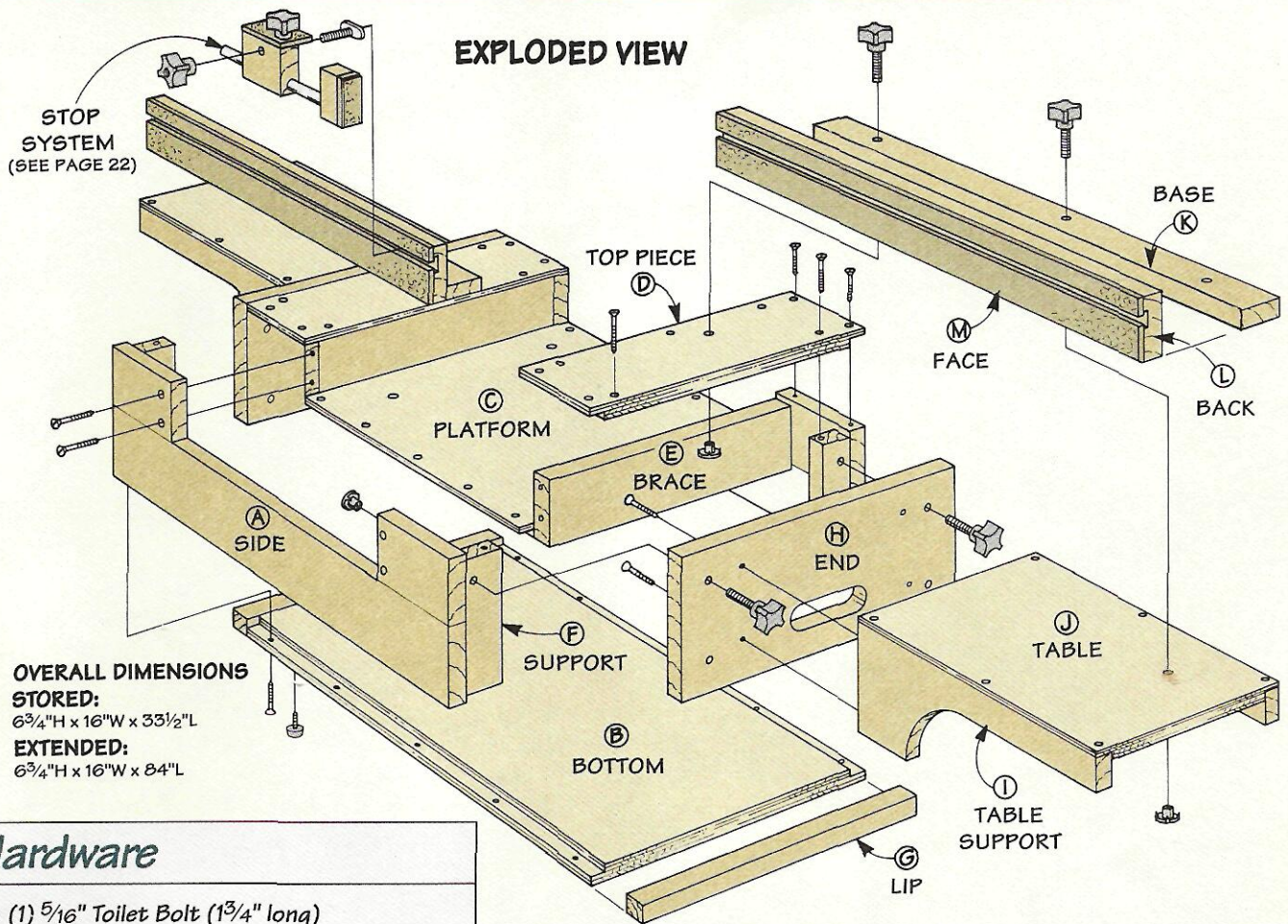

**OVERALL DIMENSIONS STORED:**  
 $6\frac{3}{4}$ "H x 16"W x  $33\frac{1}{2}$ "L  
**EXTENDED:**  
 $6\frac{3}{4}$ "H x 16"W x 84"L

### Hardware

- (1)  $\frac{5}{16}$ " Toilet Bolt ( $1\frac{3}{4}$ " long)
- (1)  $\frac{5}{16}$ " Plastic Knob
- (12)  $\frac{5}{16}$ " T-nuts
- (8)  $\frac{5}{16}$ " x  $1\frac{1}{2}$ " Threaded Knobs
- (2)  $\frac{5}{16}$ " Threaded Inserts
- (1)  $\frac{5}{16}$ " x  $2\frac{1}{4}$ " Threaded Knob
- (1)  $\frac{5}{16}$ " x 1" Threaded Knob
- (1)  $\frac{3}{8}$ "-dia. x 36"-long Steel Rod
- (4) Rubber Feet  $\frac{5}{16}$ " x  $\frac{3}{4}$ "
- (4) Bolts and T-nuts to Mount Miter Saw
- (46) No. 8 x 1" Flathead Woodscrews
- (26) No. 8 x  $1\frac{3}{4}$ " Flathead Woodscrews

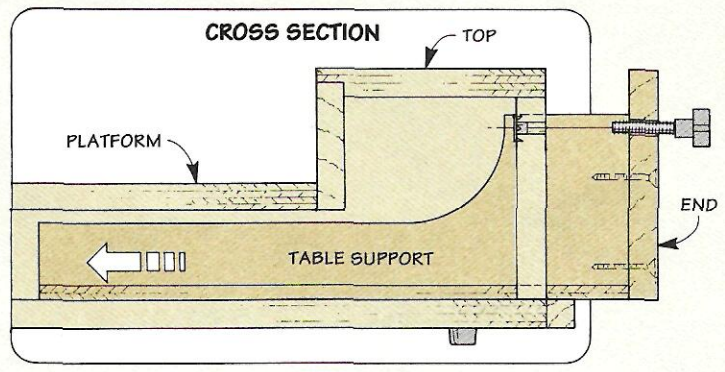

### Materials

#### CASE

A Sides (2)	$\frac{3}{4}$ x 6 - 32
B Bottom (1)	16 x 32 - $\frac{3}{4}$ plywood
C Platform (1)	16 x 20 - $\frac{3}{4}$ plywood
D Top Pieces (2)	6 x 16 - $\frac{3}{4}$ plywood
E Braces (2)	$\frac{3}{4}$ x $3\frac{3}{8}$ - $14\frac{1}{2}$
F Supports (4)	$\frac{3}{4}$ x $1\frac{3}{4}$ - $5\frac{1}{4}$
G Lips (2)	$\frac{3}{4}$ x $\frac{3}{4}$ - 16
H Ends (2)	$\frac{3}{4}$ x 6 - 16
I Table Supports (4)	$\frac{3}{4}$ x $4\frac{1}{8}$ - $15\frac{7}{8}$
J Tables (2)	$10\frac{7}{8}$ x $15\frac{7}{8}$ - $\frac{3}{4}$ plywood

#### FENCE & STOP SYSTEM

K Bases (2)	$\frac{3}{4}$ x 2 - 32
L Backs (2)	$\frac{3}{4}$ x 3 - 32
M Faces (2)	3 x 32 - $\frac{1}{4}$ Masonite
N Clamp Block (1)	$\frac{3}{4}$ x 3 - 3
O Cap (1)	$1\frac{3}{4}$ x 3 - $\frac{1}{4}$ Masonite
P Stop (1)	$\frac{3}{4}$ x 1 - 3
Q Stop Face (1)	$\frac{3}{4}$ x 3 - $\frac{1}{4}$ Masonite
R Rod Clamp (1)	$1\frac{3}{8}$ x $1\frac{1}{2}$ - 3 (optional)
S Block (1)	$\frac{3}{4}$ x 1 - 4 (optional)
T Block Face (1)	$\frac{3}{4}$ x 4 - $\frac{1}{4}$ Mas. (optional)

# The Case

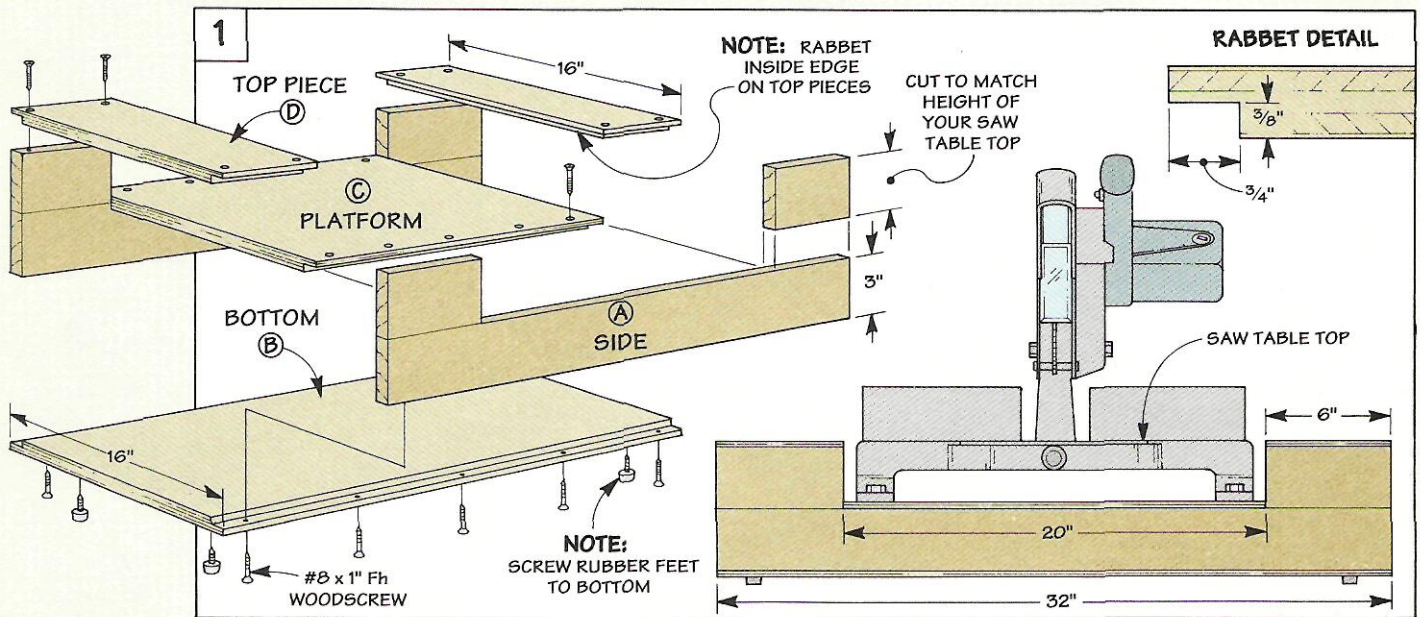

I started work on the Miter Saw Station by making the case. It's basically an open-ended box with U-shaped sides, see Fig. 1.

**SIDES.** The U-shape forms a recess for the miter saw to sit in, see Fig. 1. At the same time, this creates a work support surface on either side of the saw, see Fig. 1.

To fit most 10" miter saws, the recess in each *side (A)* is 20" wide. (Note: For a sliding compound or large miter saw, you may need to adjust the case dimensions.)

The important thing is that the top of the case end up flush with the table of your saw. For this to happen, the height (width) of the short pieces that form the sides of the "U" must match the height of the saw table top, see Fig. 1.

**BOTTOM, PLATFORM, & TOP.** The *bottom (B)*, *platform (C)*, and *top pieces (D)* are all the same width (16"). But the lengths of these pieces vary, see Fig. 1. To keep the pieces aligned, I cut rabbets on the edges, see Fig. 1. Then I glued and screwed the case together.

**BRACES.** Next, to strengthen the case and help prevent it from racking, I added two hardwood *braces (E)*, see Fig. 2. They fit between the sides and under the

top pieces (D), see Fig. 2.

**MOUNT SAW.** At this point the saw can be attached to the case. To do this, center the saw from side to side on the platform. And slide it as close to the *front* edge as possible. Then drill holes and secure the saw with T-nuts and hex bolts, see Fig. 2a.

**SUPPORTS.** Next, two *supports*

(F) are glued in each end of the case, see Fig. 3. These supports are used later to mount the wings. Note: I found it easiest to drill holes in the supports (for the wings) before gluing and screwing them in place, see Fig. 3.

To complete the case, I screwed four rubber feet to the bottom, refer to Fig. 1.

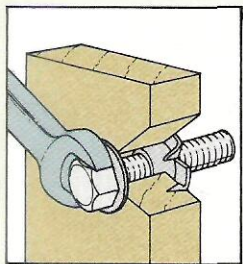

An easy way to "draw" a T-nut into hardwood is to use a wrench and a hex-head bolt.

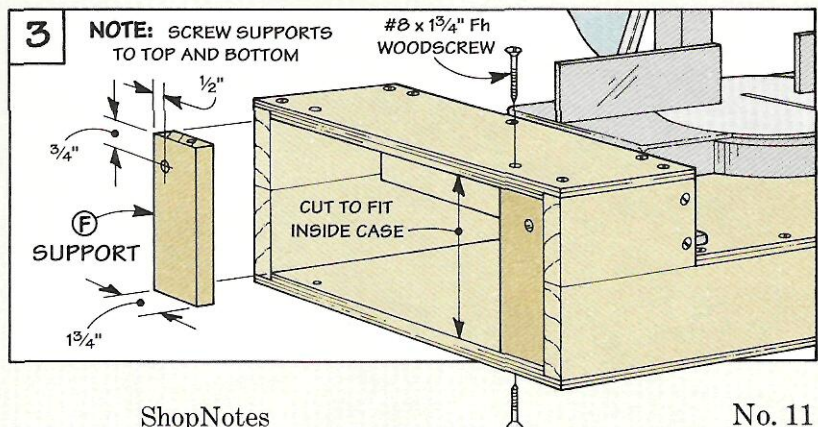
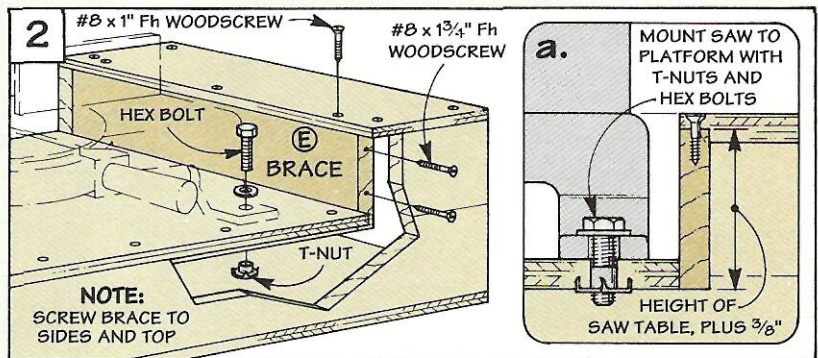

# The Wings

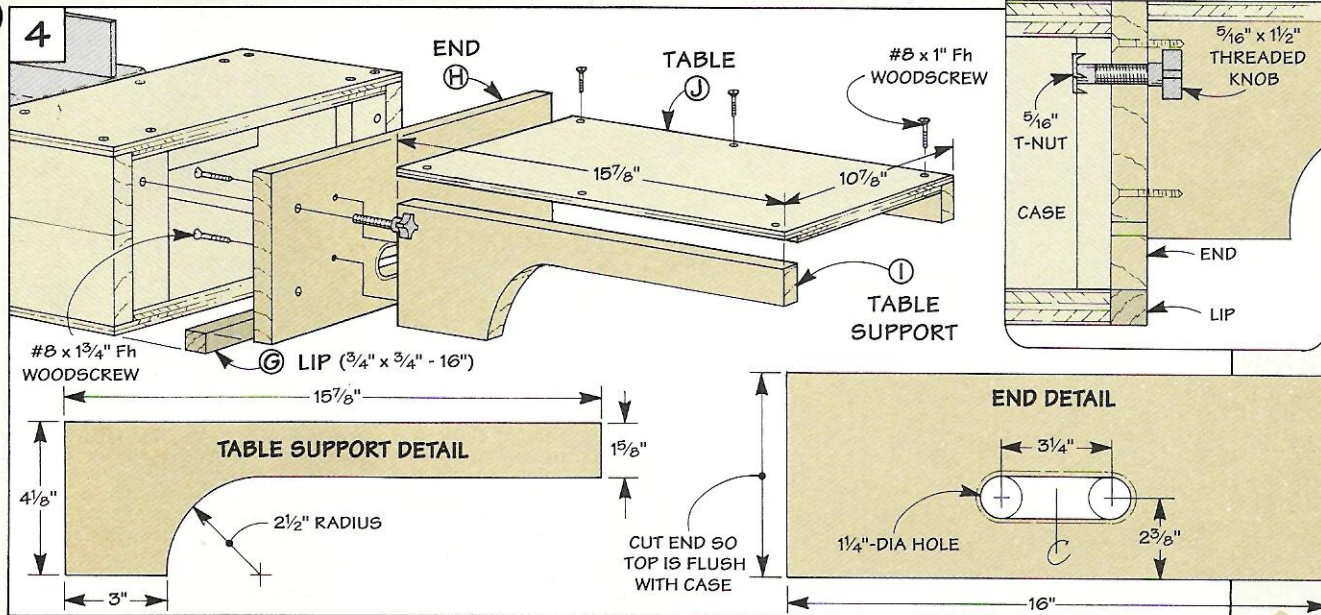

After completing the case, I added a pair of wings to support long workpieces, see Fig. 4.

**LIP.** But before work can begin on the wings, you'll need to glue a hardwood lip (G) across each end of the case, see Fig. 4. This lip covers the edge of the plywood bottom (B) and helps to support the wings.

**WINGS.** With the lips glued in place, you can make the wings. Each wing consists of an end, two supports, and a table, see Fig. 4.

The first step is to make the ends. To prevent a workpiece from catching on the wings, it's important that the ends (H) be flush with the top of the case. The height of the ends (H) is the distance from the top of the lip to the top of the case (in my case, 6").

To complete the ends (H), I cut a handle hole in each to make it easy to move the saw, see Fig. 4.

**SUPPORTS & TABLE.** Attached to each end (H) are two table supports (I) and a table (J), see Fig. 4. To size the table so the wings will fit inside the case, measure between the supports (F) and subtract 1/8" for clearance (10 7/8"). Then rabbet the edges and glue and screw the wings together.

**ATTACH THE WINGS.** In order to knock down and set up the wings quickly, they're held in place with threaded knobs (or thumbscrews) and T-nuts. (For hardware sources, see page 31.) The threaded knobs pass through the holes you drilled earlier in the supports (F) and thread into T-nuts, see Fig. 4a.

Two sets of holes in each wing

allow you to use the same knobs to secure the wing in either the open or stored position. The tricky part is aligning these holes with the ones you drilled in the supports (F). To do this, I used dowel centers, see Figs. 5 and 6.

After drilling the holes, install the T-nuts. Finally, position the wings and thread in the knobs.

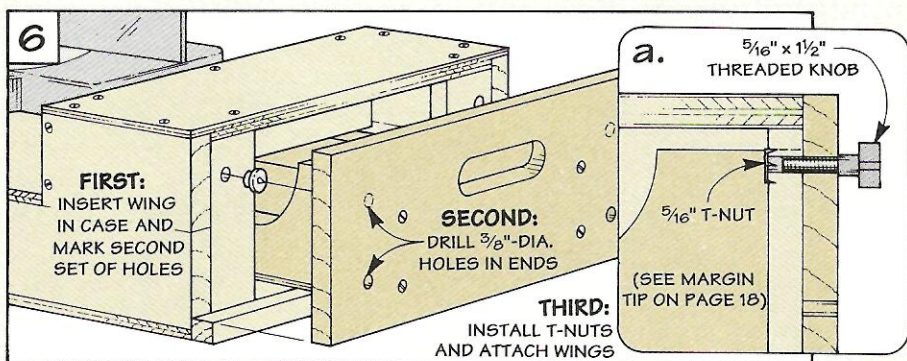
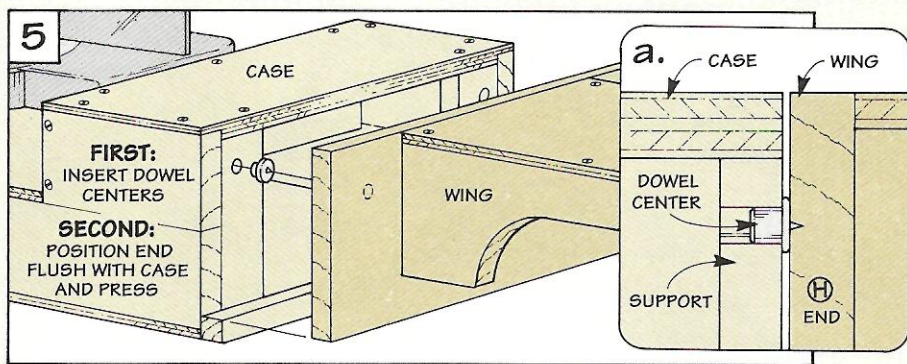

# The Fence Rails

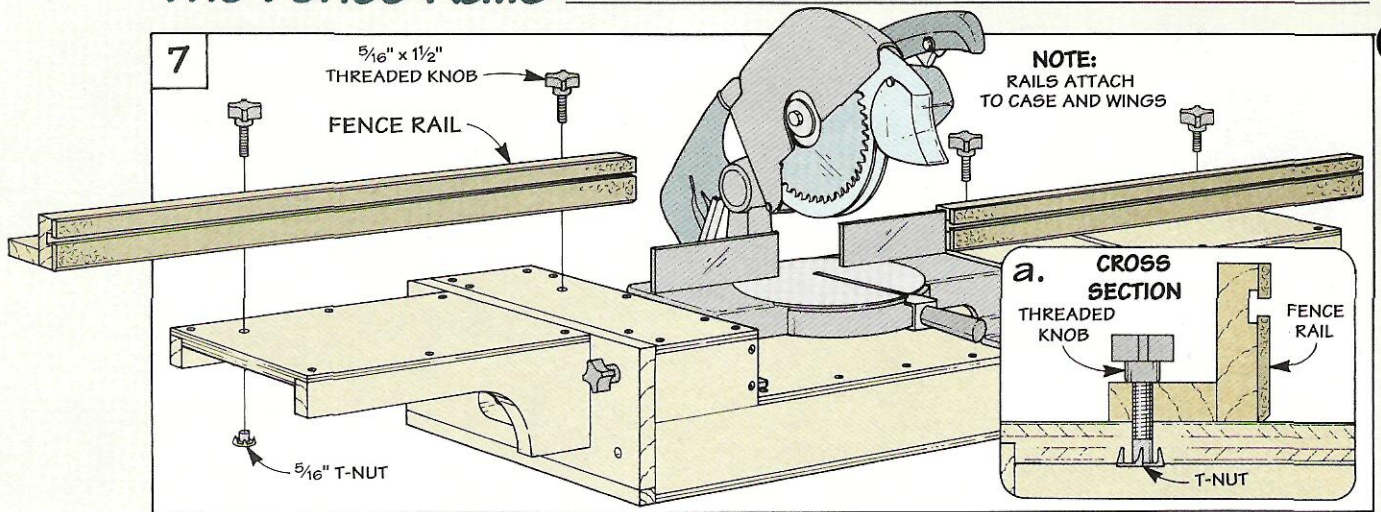

Once the wings are complete, the station is ready to use. But I've never been satisfied with the short fences on my miter saw. It's awkward to position and hold a long workpiece. And for repeat cuts, there's nothing to clamp a stop block to.

To solve both of these prob-

lems, I added a pair of shop-built rails, see Fig. 7. They feature a built-in T-slot for a stop system added later. And just like the wings, the rails attach to the case with threaded knobs. This way they can be easily removed (and stored, see page 21).

**THREE PARTS.** Each fence rail

is made up of three parts: a base, back, and face, see Fig. 8. The *base* (K) provides a foundation for the back. And two mounting holes drilled in each piece allow you to attach the rails to the case later, see Figs. 7 and 8.

Each *back* (L) supports the workpiece and is grooved for the stop system added later, see Fig. 8. After each groove is cut, a back is glued to a base to form an "L," see Fig. 8.

For accurate cuts, it's important that the back is 90° to the base. So before you glue these pieces up, dry clamp them and check for square.

Note: Make sure to glue on each base (K) to create a *right* and a *left* fence rail. (The end of each base with the mounting hole should face *in* toward the saw, see Figs. 7 and 8.)

**FACE.** The next step is to add the face pieces. Each *face* (M) is cut from 1/4" -thick Masonite and is glued on top of the groove in each back, see Fig. 8.

Note: After gluing on the faces, sand or rout a chamfer on the bottom *front* edge for sawdust relief, see Fig. 8.

**T-SLOT.** Finally, to create the "T" and provide a rock-solid way to lock the stop system in place, a slot is cut in each face, see Figs. 9 and 9a.

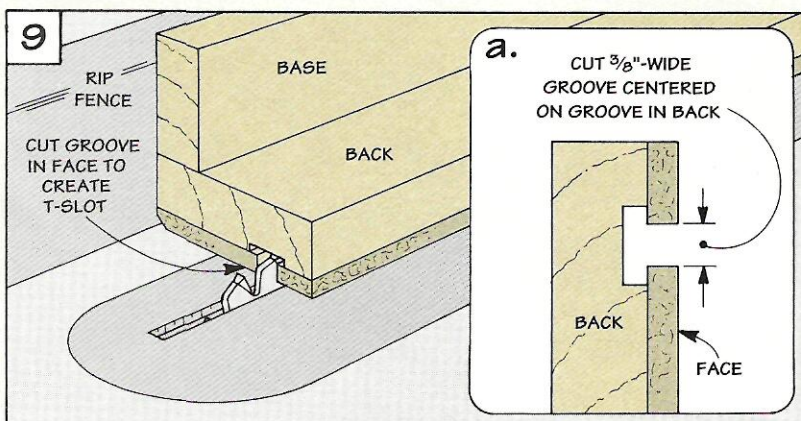
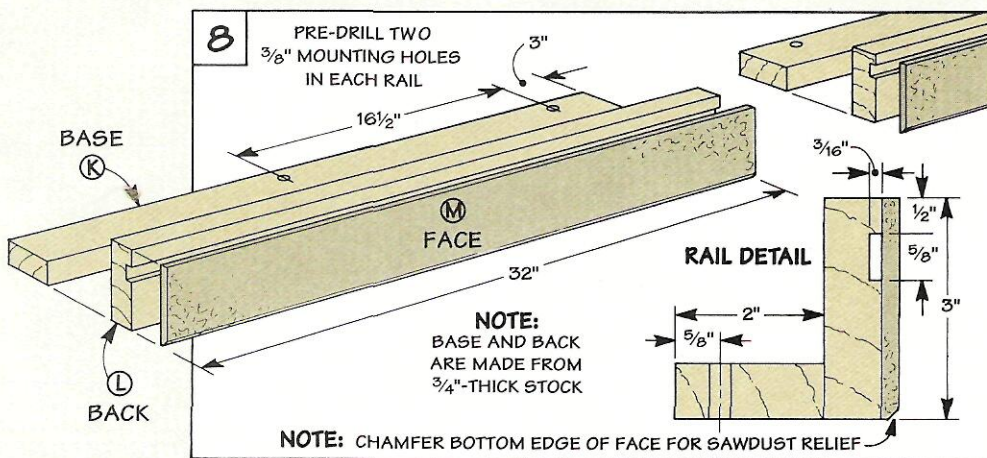

# Mounting the Rails

After the fence rails are finished, they can be attached to the case. Just like the wings, the rails are held in place with threaded knobs and T-nuts, see Fig. 10.

The tricky part is mounting the rails so they're in line with the miter saw fence. To do this, I use a long straightedge (in my case, a four foot level) to position the rails, see Fig. 10.

**MOUNTING HOLES.** To locate the holes for the T-nuts, clamp the straightedge to the saw fence, and the fence rail to the wing, see Fig. 10. Then hold the other end of the rail in place and drill through the holes in the fence base and into the case and wings, see Fig. 10a.

Note: To make it easy to realign the rails whenever they're removed, see margin tip at right.

**T-NUTS.** All that's left is to add T-nuts and threaded knobs and screw the rails in place.

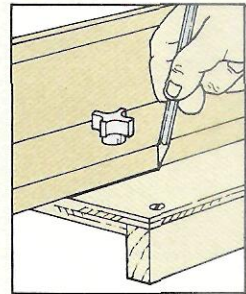
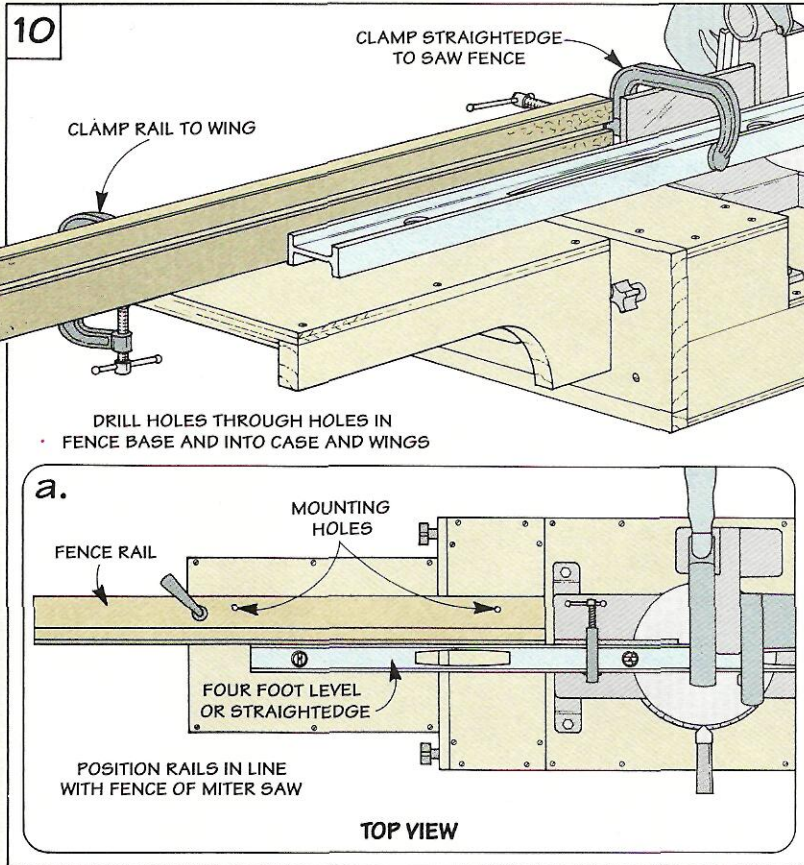

To make it easy to reposition the rails, mark a reference line on the table.

# Storing the Fence Rails

To make it as convenient as possible to lift and move the Miter Saw Station, the rails can be mounted out of the way on the rear of the case, see Drawing. They're held in place with the same knobs used to mount them on top of the case, see Drawing.

**THIRD HOLE.** To bolt both rail ends to the case, you'll need to drill a third  $\frac{3}{8}$ "-dia. mounting hole in each fence rail, see Drawing.

Then, to locate the matching holes in the case for the T-nuts, just hold each rail up against the case. And drill

through the hole in each end of the rail and into the side, see Drawing and Cross Section.

**MOUNT RAILS.** Finally, to secure the fence rails, insert the T-nuts and screw the rails to the case with the threaded knobs, see Drawing.

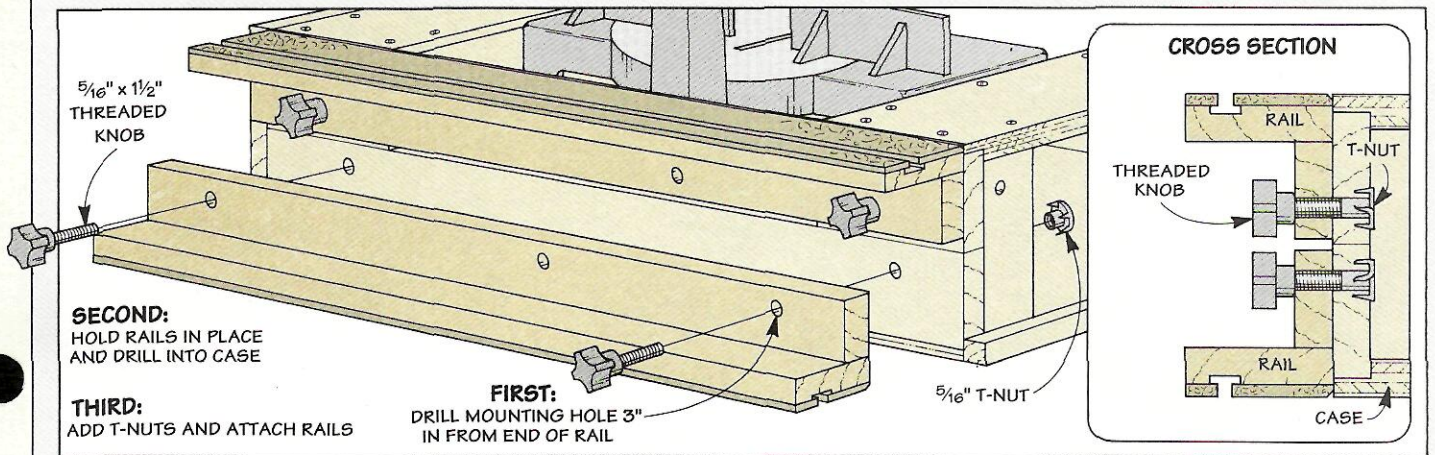

# The Stop System

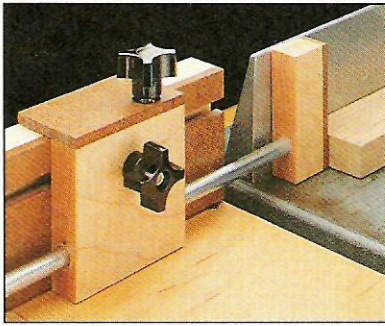

With the fence rails mounted, work can begin on the stop system. To allow you to make quick and accurate repeat cuts, the stop system slides in the T-slot in the fence rails, see Fig. 11.

**THREE PARTS.** The only problem is there isn't a T-slot in the miter saw fence. In order to use the stop close to the saw blade, the stop is made up of three parts: a clamp block, a length of steel rod, and a sliding stop. This way you can extend the stop out over the table of the miter saw, see photo above.

**CLAMP BLOCK.** I started work by making the *clamp block* (N), see Fig. 12. The clamping action is provided by a toilet bolt (available at most hardware stores). It passes through the block and fits in the T-slot in the fence rail, see Fig. 11a. Tightening a plastic knob (or wing nut) on the end of the bolt pinches the bolt in the slot and locks the stop in place.

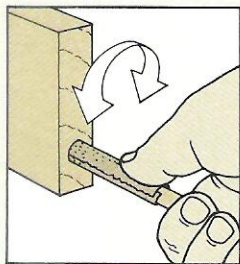

To prevent the steel rod from binding, use a dowel wrapped with sandpaper to enlarge the hole.

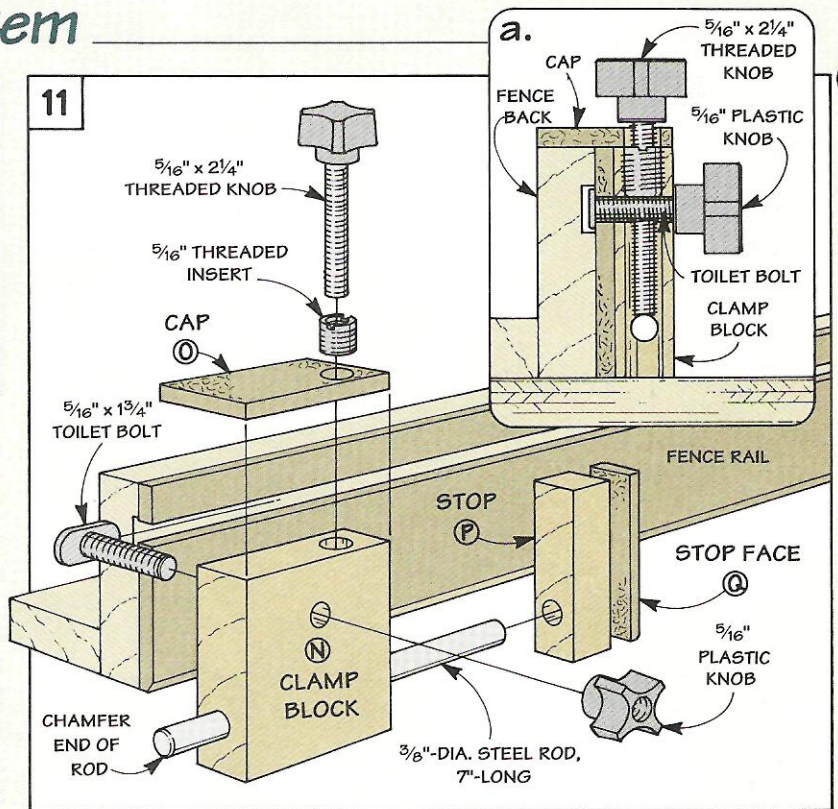

Next, a hole is drilled the length of the block to accept a steel rod, see Fig. 12 and margin tip at left.

To help prevent the clamp block from twisting and binding as it slides back and forth, I glued a 1/4"-thick Masonite *cap* (O) to the top of the block, see Fig. 12.

**THREADED INSERT.** In use, the steel rod is locked in place with a threaded knob (or thumbscrew). It runs through a threaded insert in the clamp body to pinch the rod in the hole, see Figs. 12 and 12a.

**STOP.** Next, I added a *stop* (P) to the end of the rod, see Fig. 13. Safety Note: To keep your hands away from the blade, the stop doesn't extend all the way to the blade — it stops 6" away from it.

To strengthen the stop, I glued a Masonite *face* (Q) to one end, see Fig. 13. And for sawdust relief, I sanded a chamfer on all edges.

Finally, epoxy the steel rod in the stop. When it's dry, slide it into the clamp body and attach the stop system to the fence rail.

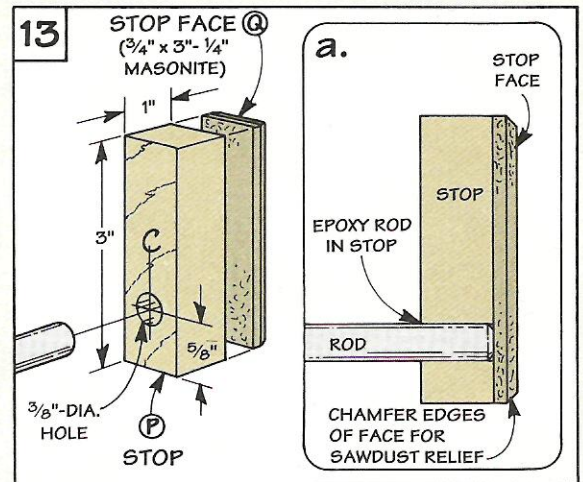
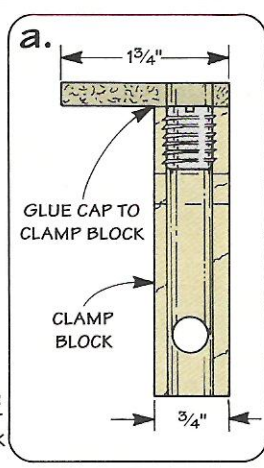
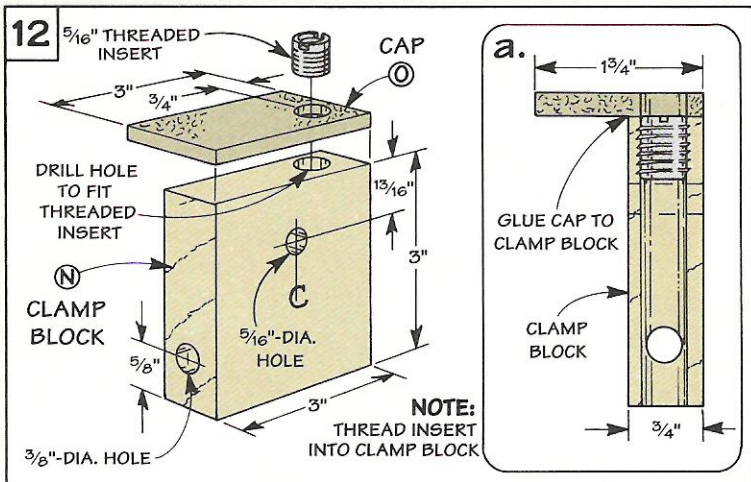

# Using the Stop

## Closed

For the majority of cuts I make, I butt the stop (P) up against the clamp block (N) and lock it in place, see Drawing.

Now to set the stop for a repeat cut, first loosen the plastic knob on the clamp block. Then slide the entire assembly for the desired cut and lock it in place.

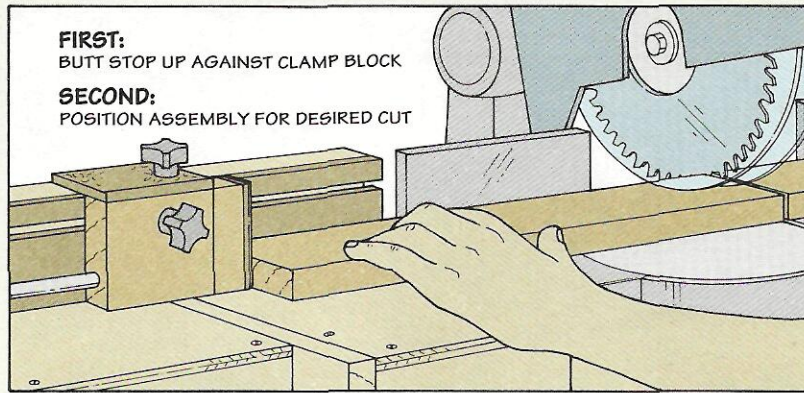

## Extended

To cut shorter workpieces, slide the stop near the end of the rail and lock it in place, see Drawing.

Then loosen the threaded knob on top of the clamp block and extend the stop (P) out for the desired cut. Safety Note: The stop should always be at least 6" away from the blade.

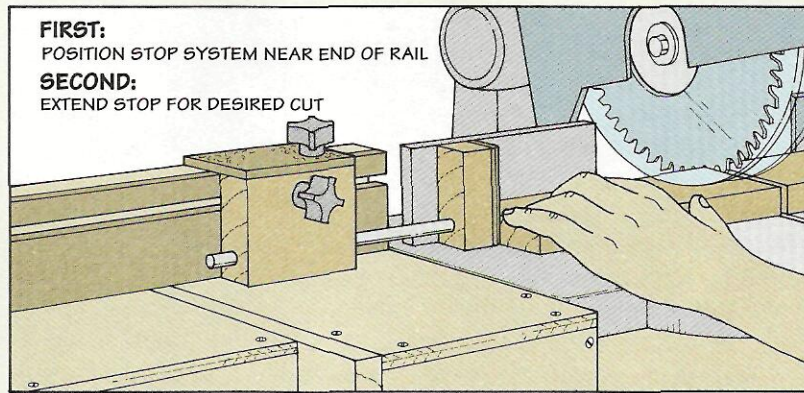

## Optional Stop for Long Stock

To make repeat cuts on stock longer than the fence rails, I added an optional stop, see photo. It's similar to the fence system except it fits *under* the left wing.

The optional stop consists of a rod clamp (R) and a two-piece stop, see Figs. 1 and 2. These two parts are connected with a 3/8"-diameter steel rod.

Note: Since I wanted to store the stop in the case and still get the maximum extension, the steel rod is cut 22" long.

**MOUNT STOP.** To mount the assembled stop, position it under the wing so it butts up against the *face* of the fence rail. Then glue and screw the clamp block to the wing table (J), refer to Fig. 1.

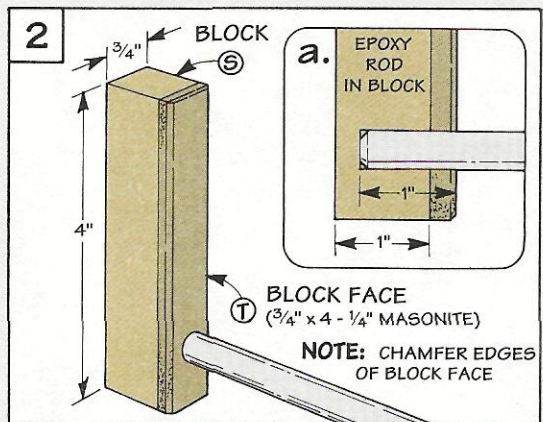
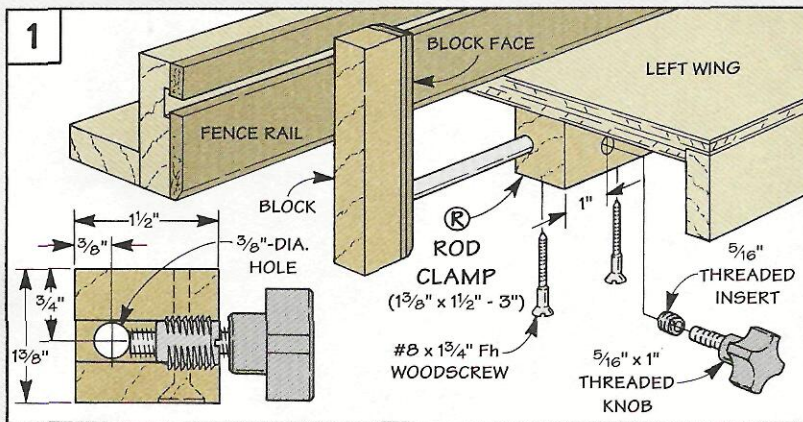
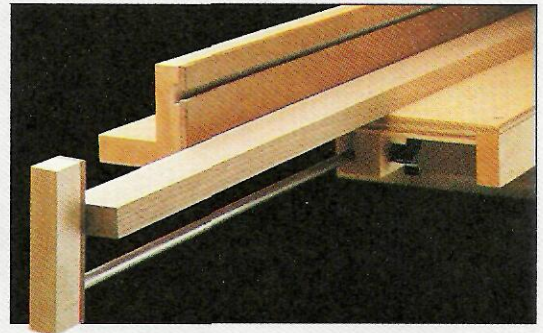

# Sharpening with Sandpaper

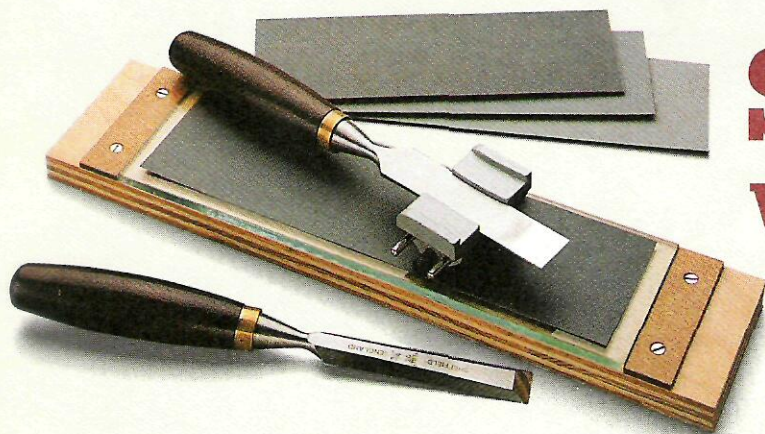

*Silicon carbide sandpaper provides a quick and inexpensive way to get a razor sharp edge on a chisel or plane iron.*

One thing I've learned over the years is there's more than one way to get a job done right. Take sharpening a chisel or plane iron for example. Lately, I've been experimenting with a slightly "offbeat" technique that doesn't even require a sharpening stone. Yet it produces a sharp edge in a matter of minutes.

**SANDPAPER.** The key to this system is an inexpensive (yet effective) abrasive that's available at most hardware stores — *Wet or Dry* silicon carbide sandpaper. What makes it such a good choice for sharpening is the particles of silicon carbide that are bonded to the paper. They're extremely hard and sharp, so they cut quickly.

Another advantage to silicon carbide paper is it can be used

either wet or dry. I prefer to use it "wet" by spraying water on the sandpaper. (I mist it with a spray bottle.) This floats the filings away and keeps the paper from clogging up. And since it has a waterproof backing, the paper won't fall apart as you're sharpening.

**THE EDGE.** Whether you use the paper wet or dry, the thing to keep in mind as you're sharpening is the geometry of the cutting edge. It's formed by the intersection of two surfaces — the *back* and the *bevel*, see Fig. 1. To create a sharp edge, the secret is to make both of these surfaces as smooth and flat as possible.

**GLASS.** The only way to ensure a perfectly flat back (or bevel) is to work off a surface that you know is flat. I use a piece of 1/4"-

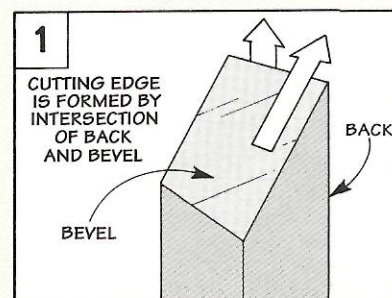

thick glass, see box below. But the bed of a jointer or a table saw would also work. Note: If you're using the paper "wet," be sure to use a lubricant like WD-40 to prevent rust.

## FLATTEN THE BACK

Although flattening the back requires a little elbow grease, the nice thing about it is you only need to do it one time. Once it's

## Sharpening Platform

A piece of glass provides an ideal surface for flattening the back or bevel of a blade. But it has a tendency to slide back and forth as you're sharpening.

To hold the glass in place, I use a simple sharpening platform, see Drawing. This is just a scrap piece of plywood with Masonite cleats attached at each end of the glass.

Another advantage of the platform is it keeps metal filings from spreading out onto your work area.

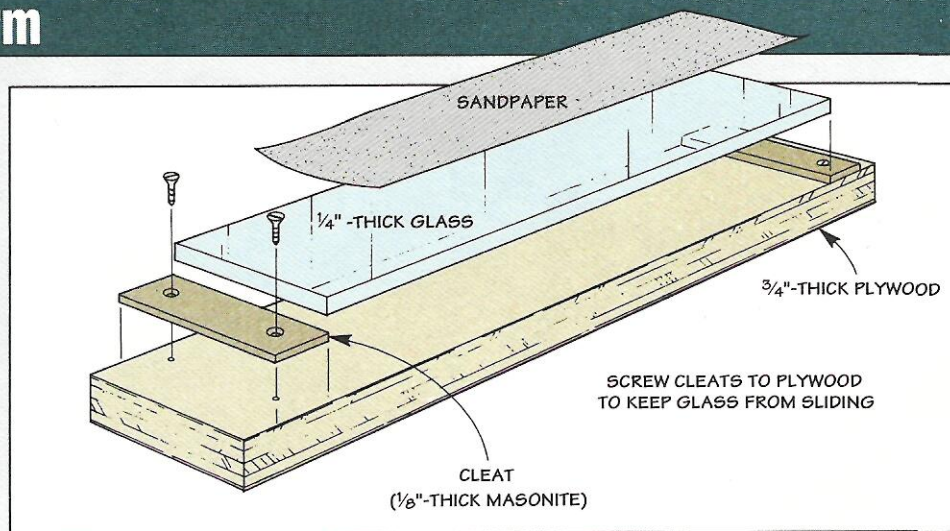



flat, you just need to concentrate on the bevel the next time you sharpen the blade.

So why bother with the back at all? Because even with a brand new chisel, it may not be perfectly flat. If the back has a slight hollow, you end up with a "dished" cutting edge, see Fig. 2. A crown on the back results in a curved edge.

To eliminate these problems, I start with a piece of 240 grit sandpaper and work on about a 1"-long area behind the cutting edge. Note: Spraying some water on the glass before positioning the paper creates a surface tension that helps keep the paper from sliding back and forth.

When flattening the back, the idea is to apply pressure over the beveled end of the blade and make firm, even strokes across the sandpaper, see Fig. 3. As the sanding progresses, you'll begin to see a shiny surface develop on the back of the blade. When it extends clear across the blade, the back is flat.

**POLISH BACK.** Even when the back is flat, it still needs some work. That's because the coarse grit paper leaves large scratches behind. Each of these scratches forms a tiny nick where it meets

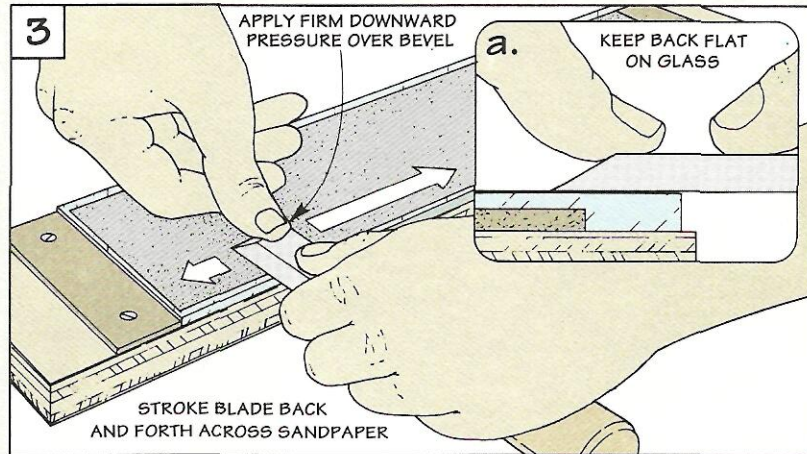
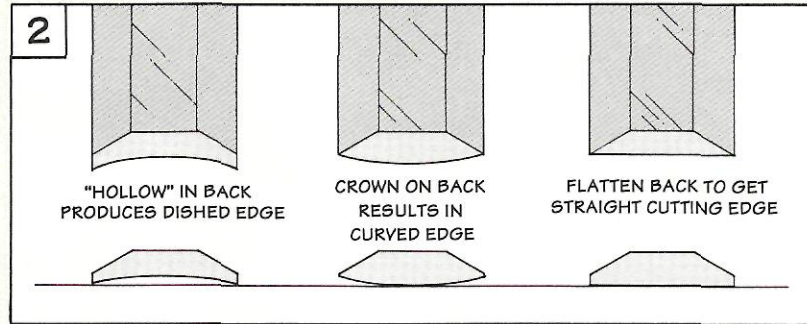

the cutting edge of the blade.

**RANGE OF GRITS.** To remove these scratches, I polish the back with a progression of finer grits. I move on to 400 grit next, and then follow it up with 800 and 1,000 grit sandpaper.

While this produces a serviceable edge, I like to continue polishing with 1,500 and 2,000 grit

paper to get a mirror smooth finish. (I found these extra fine grits of sandpaper at an auto body parts store.)

**SQUARE THE EDGE.** Once the back is flat and smooth, there's one more thing to do before you begin work on the bevel. That's to check that the edge is square, see the box below.

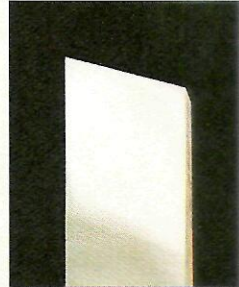

To lay the groundwork for a sharp edge, the back of the blade is polished to a mirror smooth finish.

## Squaring the Edge

After flattening the back, I make it a habit to check that the cutting edge is square to the sides.

This is especially important when sharpening a plane iron. That's because most planes are designed to hold a blade with an edge that's 90° to the sides.

Fortunately, there's nothing complicated about reshaping the edge. Start by squaring a line across the back of the blade, see Drawing. Note: To keep the line from rubbing off, I use a fine tip

permanent marker.

If a lot of material needs to be removed to square up the edge, I make a few *light* passes across the high corner with a file. But if the edge is reasonably close, I use a slightly different approach.

Basically, the idea here is to square up the edge *and* flatten the bevel at the same time. This is just a matter of applying more pressure to the high corner as you're sharpening. (For more on this technique, refer to page 26.)

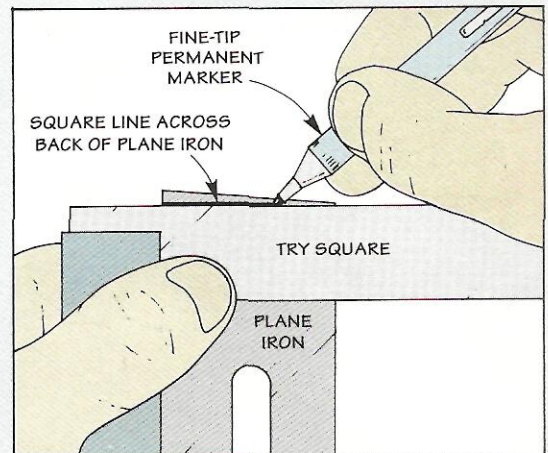

## Flattening the Bevel

Once the back is flat and you've polished it to a smooth finish, you're halfway to a sharp edge. Now you can concentrate on the bevel. The goal here is to make the surface of the bevel as flat and smooth as the back.

**CONSISTENT ANGLE.** The key to getting a smooth, flat bevel is to hold the chisel (or plane iron) at a consistent angle to the sharpening surface. The problem is it's difficult to hold the blade at the correct angle as you sharpen it.

**HONING GUIDE.** To solve this, I mount the blade in a honing guide, see Fig. 4. There are several different styles of honing guides available. The one I prefer to use is nothing more than a rolling clamp that holds the blade at the desired angle: (For information on this guide, see box below.)

**FLATTEN THE BEVEL.** With the blade mounted in the honing guide, you're ready to flatten the bevel. Here again, the idea is to use silicon carbide paper and proceed from a coarse to a fine grit. The trick is knowing where to start.

**GRITS.** Basically, this requires matching the grit to the condition of the bevel. To remove a nick in

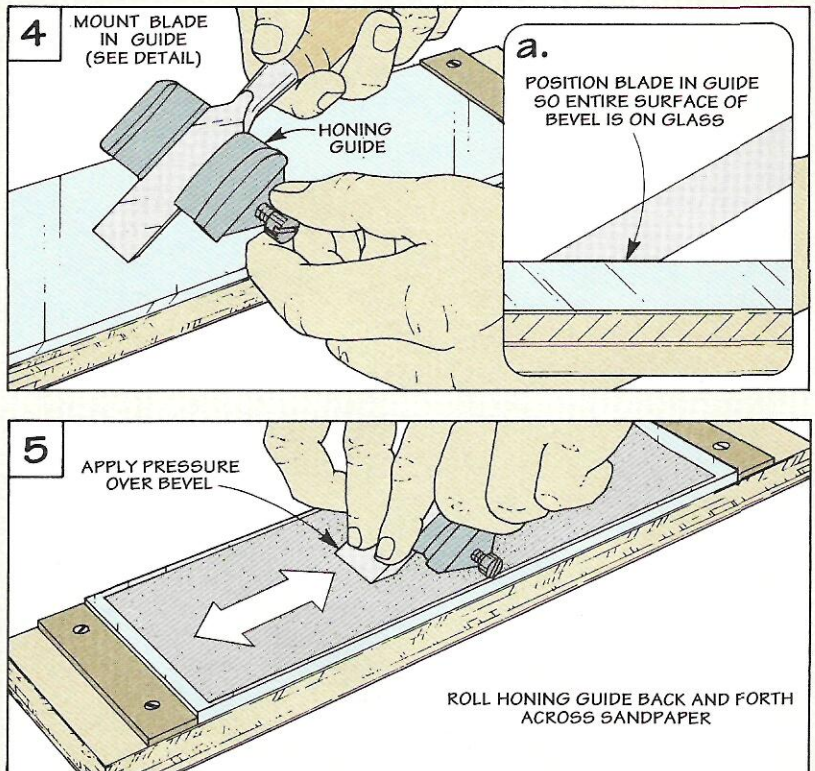

the edge, I "rough shape" the bevel with a piece of 180 grit paper. But for most work, this is just too coarse.

For example, if I'm sharpening a brand new chisel for the first time, I'll start with a piece of 240 grit paper. Or, if I'm just touching up an edge, a few strokes on a

piece of fine grit sandpaper is all that's needed.

**EVEN PRESSURE.** Regardless of the grit, the important thing is to apply *even* pressure on the blade. To keep the honing guide from rocking side to side, I place my thumbs behind the guide and press my fingertips down on the

## Honing Guide

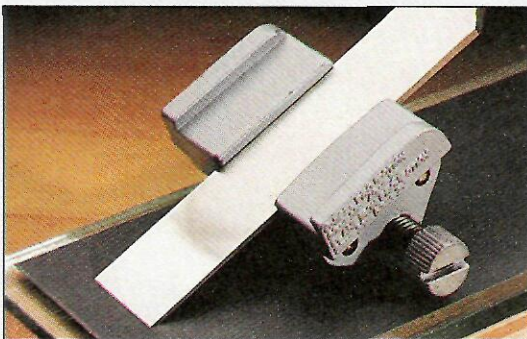

By holding a chisel (or plane iron) at a consistent angle to the sharpening surface, this honing guide ensures that the bevel remains flat as you're sharpening.

This honing guide solves the biggest problem of getting a perfectly flat bevel — holding the chisel or plane iron at a consistent angle.

To secure the blade, there are two pairs of adjustable jaws: a wide set for plane irons, and a narrow set for chisels, see Drawing.

Regardless of which set of jaws you're using, the angle of the bevel depends on how far the blade projects in front of the guide. I match the existing angle by positioning the blade in the jaws so the entire surface of the bevel is flat.

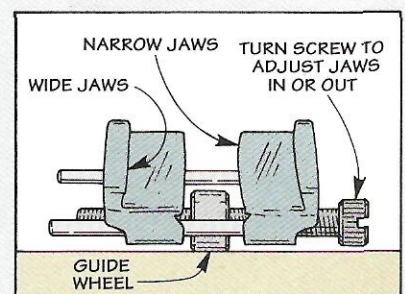

Then just tighten the screw that locks the jaws, and apply pressure to the blade as you roll the guide across the sharpening surface. (For sources, see page 31.)

back of the blade right over the bevel, see Fig. 5. Now it's simply a matter of rolling the guide back and forth across the sandpaper.

As you're sharpening, it's a good idea to check your progress frequently. You're looking for two things here: a square cutting edge and a small metal "hook" or burr that forms when the back meets the surface of the bevel, see Fig. 6a.

**SQUARE.** The edge is easy to check for square. I either use a small try square or compare the edge to the line drawn across the back of the blade earlier, refer to box on page 25. If one corner is higher than the other, just continue sharpening and apply more pressure over the high corner.

**BURR.** Another good indicator of your progress is the burr. Since it's too small to see, you'll need to feel it by drawing your finger up the back of the blade, see Fig. 6. Safety Note: Don't pull your finger along the edge. The idea is to keep sharpening until there's a nice *even* burr across the entire width of the blade.

**REMOVE BURR.** When you can feel a burr across the back of the blade, the next step is to remove it with a piece of sandpaper. To

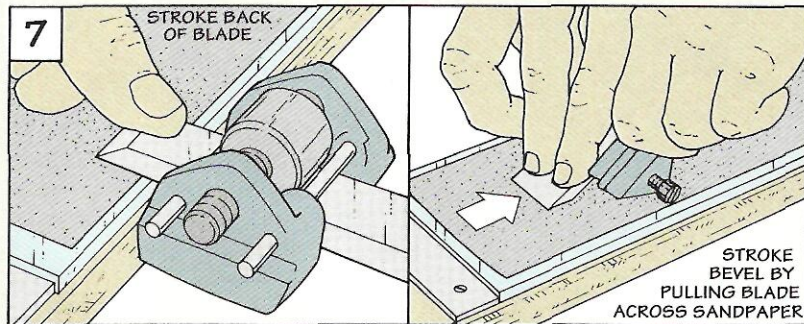
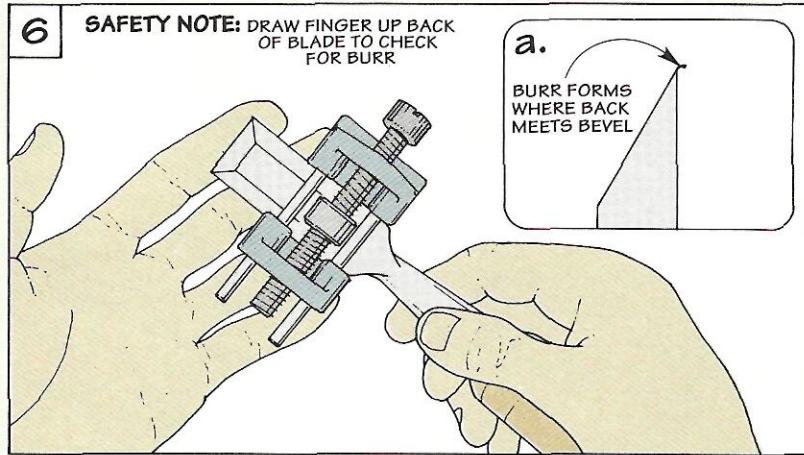

avoid putting deep scratches in the back, I switch to the *final* grit paper that was used to polish the back.

Now, without taking the blade out of the honing guide, alternately stroke the back and the bevel across the sandpaper, see Fig. 7. This bends the burr back

and forth until it breaks off.

**POLISH BEVEL.** All that's left to produce a razor sharp edge is to continue polishing the bevel using progressively finer grits of paper. As before, check the edge for square, and remove the burr at each stage before going on to the next grit.

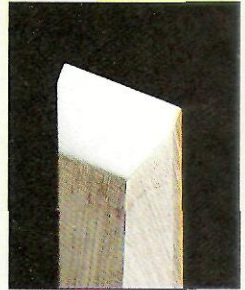

To create a razor sharp edge, the bevel is flattened so it's perfectly smooth and flat.

## Touch-Up Paddle

Sometimes all I need to do is touch up the edge of a chisel or plane iron. Rather than go through the entire sharpening process, I use a "touch-up" paddle.

This is just a piece of hardwood with fine grit silicon carbide sandpaper glued on, see Drawing. (I use a spray adhesive like 3M's Spray Mount.)

The idea here is to rest the bevel flat on the paddle. Then pull the blade toward you a couple of times. This creates a very fine burr that's easily removed.

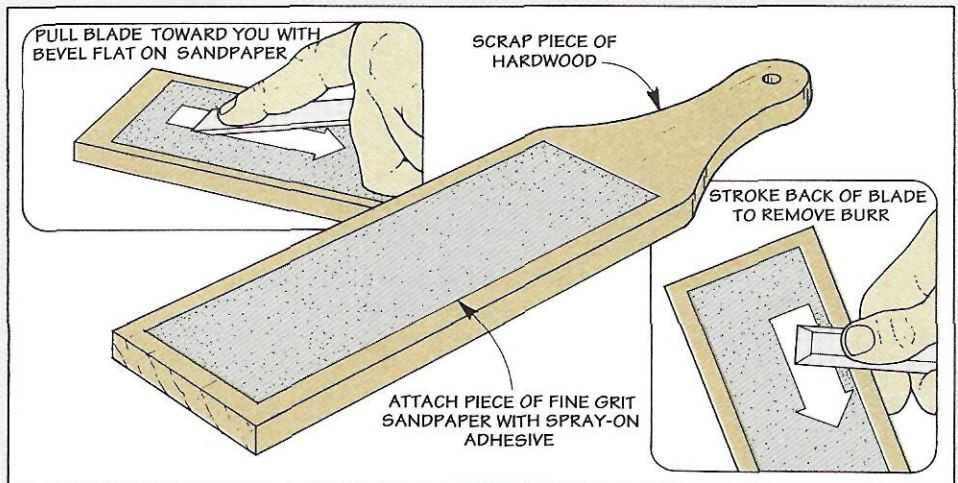

# Shop Solutions

## Frame and Panel Jig

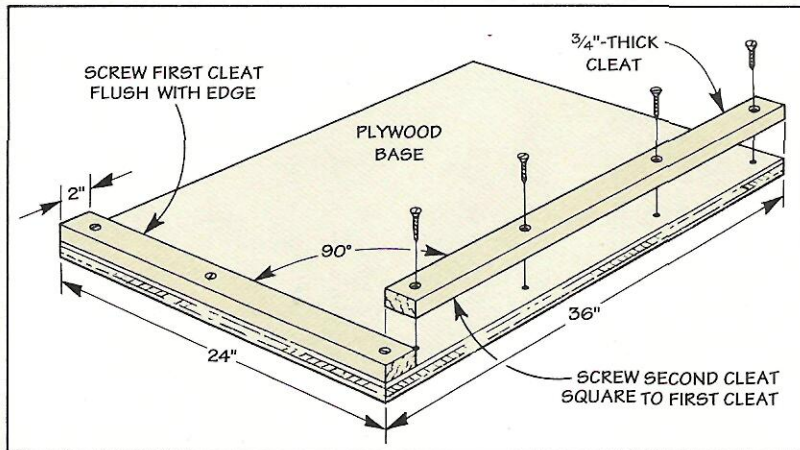
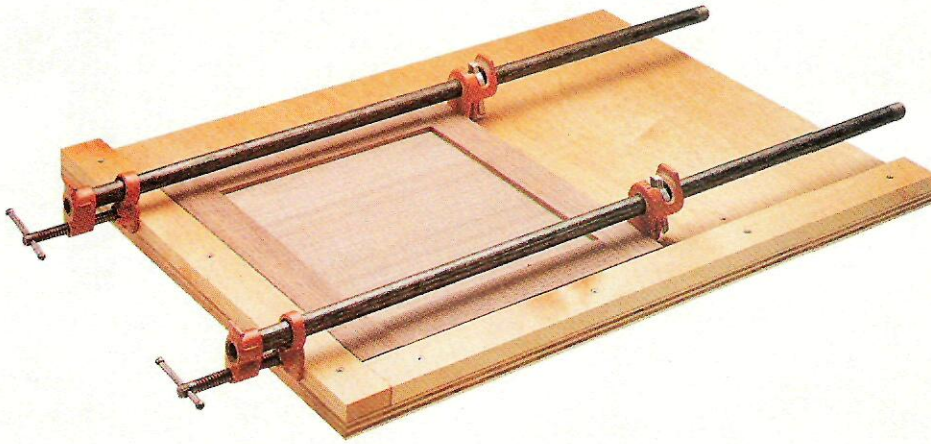

■ Gluing up a frame and panel door so it ends up perfectly square can be difficult. The pieces always seem to slip out of square during glue-up.

To get around this, I built a simple jig that provides an accurate reference when gluing up panels, see photo.

The jig consists of a plywood base and two cleats, see Drawing. To provide an accurate reference, it's important that the cleats are screwed to base so they're 90° to each other.

To use the jig, start by placing each clamp directly over (and parallel to) the rails of the frame. Then, adjust the pressure and position of the clamps until the frame sits square in the jig.

Note: To prevent any glue squeeze-out from sticking to the jig, I brushed on several coats of polyurethane finish to the base and cleats.

*Lonnie R. Baxter  
Murfreesboro, Tennessee*

## Sanding Belt Storage Rack

■ I used to store my sanding belts in a drawer. But every time I needed to change a belt, I ended up emptying out the entire drawer to find the one I wanted. To avoid this, I made a wall-mounted storage rack for my sanding belts, see Drawing.

The rack consists of a 3/4"-thick base with dowels, see Drawing.

The dowels are spaced far enough apart so the belts hang without touching each other. And to take up the least amount of space, I mounted the rack at 45°.

*Lionel Fishman  
Los Angeles, California*

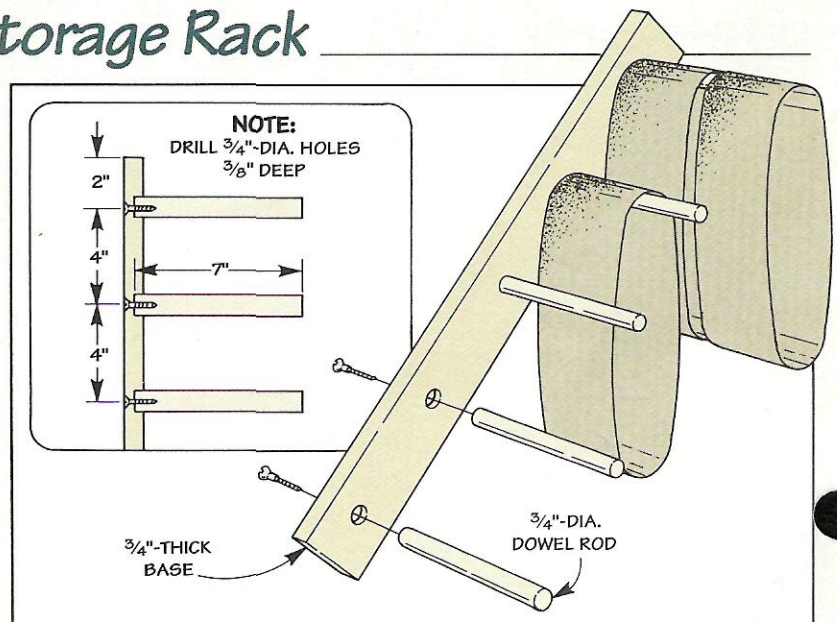

## Clamping Edging

■ I came across a problem recently when I needed to glue edging to the ends of a long table. The problem was the table was longer than my pipe clamps. So I came up with this simple technique that uses C-clamps and wedges to hold the edging in place while the glue dries, see Drawing.

To do this, first attach the C-clamps to the edge of the table

top. (To ensure a good glue joint, space the clamps evenly about 6" apart.) And to get the proper clamping pressure on the joint line, tap a small wedge between the edging and each clamp until the edging is tight.

*Spike Lacombe  
Pahrump, Nevada*

**Editor's Note:** This also works for attaching counter top edging.

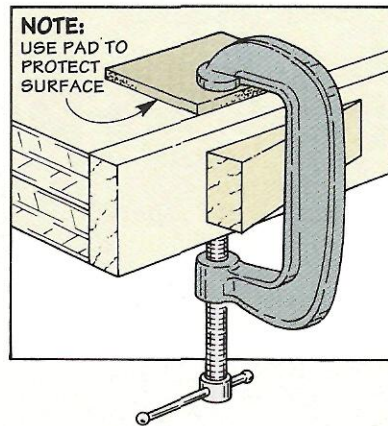

## Plugging Mortises

■ Recently I was working on a project that had a series of slats that fit in mortises. Because of the way the project was designed, it was easier to apply the finish before assembling all the pieces. The trick was keeping the finish out of the mortises — I wanted good glue joints later on.

To do this, I plugged each mor-

tise temporarily with foam caulking rod, see photo. (The caulking rod I used was slightly wider than the mortises.) After the finish dries, just remove the foam rod.

A twenty foot length of  $\frac{3}{8}$ "-dia. caulking rod purchased from my local hardware store cost \$2.50.

*Gail Jeager  
Rochester, New York*



## Quick Tips

■ Occasionally, I use adhesive-backed veneer. In the past, I'd just press the veneer down on the workpiece and roll it out until the air bubbles were gone. But sometimes after a few days the veneer would bubble back up. The surface was too porous for the veneer to stick.

To prevent this, I first seal the

workpiece with a coat of varnish. The varnish helps fill in the porous surface. And this provides a smoother work surface for the veneer to stick to.

After the varnish is completely dry, just apply the veneer as you normally would.

*Gus Klubal  
Williamstown, New Jersey*

■ To prevent a waterstone from sliding around on the workbench when sharpening a chisel or plane iron, place it on a damp cloth. The cloth sticks to the workbench and the waterstone stays on the cloth.

*James Moon  
East Point, Georgia*

**Editor's Note:** A few damp paper towels also works well.

## Sanding Guide

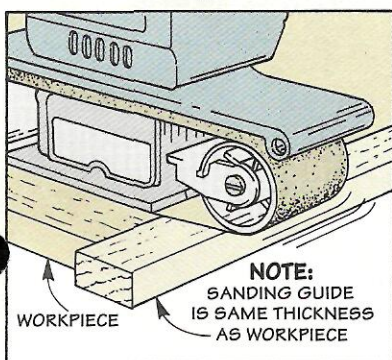

■ To prevent a power sander (particularly a belt sander) from tilting near the edge of a workpiece and rounding it over, I place another board that's the same thickness up against the workpiece, see Drawing. This way, the sander rides across the edge instead of rounding it over.

*Kent Hester  
Kremmling, Colorado*

## Send in Your Solutions

If you'd like to share your original solutions to problems you've faced, send them to: *ShopNotes*, Attn: Shop Solutions, 2200 Grand Avenue, Des Moines, IA 50312. (Or if it's easier, FAX them to us at: 515-282-6741.)

We'll pay up to \$200 depending on the published length. Please include a daytime phone number so we can call you if we have questions.

# Plywood Grades



*It's the selection of the face veneers at the factory that determines the grade of every sheet of hardwood plywood you buy.*

■ *Could you explain the coding system that's used to grade hardwood plywood? What does it all mean?*

*J. F. Swain  
Sudbury, Massachusetts*

*You can use the different grades of plywood to your advantage.*

Hardwood plywood is graded using a two part letter-number code (such as A-2). This code indicates the *appearance* of the outer plies so you can compare “apples to apples” when shopping for plywood.

The letter indicates the quality of the *face* veneer. And the number describes the *back* veneer. (Note: The grade describes appearance only — it doesn't indicate core type or strength.)

**FACE VENEERS.** The grades for face veneers range from AA to E. The highest in quality is AA, with virtually no defects. All the way down to E which is the poorest and allows the largest amount of defects (such as knots, holes, and splits). Note: D and E grade plywoods are typically used only for shipping crates and pallets.

**BACK VENEERS.** The system that's used to describe the back

veneer is similar to what's used to grade the face. The only difference is that numbers are used instead of letters. A “1” indicates best quality, and a “4” the poorest.

## BUYING TIPS

Once you understand the grading system for plywood, you can use it to your advantage.

**USE LOWER GRADES.** One trick that I've learned is to only pay for what I need.

For example, say you're building a table that has a plywood top — don't buy A-1 plywood. Since only one side of the plywood will show, you don't need two good sides. Instead, save 20% to 30% and buy a sheet of A-3 or B-4.

**REJECT BACK.** Or if you're going to build a cabinet and use plywood for the back, you can save money by buying a sheet of “reject back” or “good one side.” This non-official designation is often used to describe thin (usually ¼" thick or less) plywood.

It's typically used on imported plywood that hasn't been graded

to U.S. standards. The back veneer is usually very low quality, and can even be a different species than the face veneer — but it usually costs 30% to 40% less than a sheet of A-1.

**SHOP GRADE.** Another “grade” which doesn't appear in the official rule book is “shop” grade. A sheet of shop grade plywood is basically a factory second and is priced accordingly.

In many cases, a high quality panel is down-graded to shop grade for a very small defect (such as a split in the face veneer). In other panels there may be a larger flaw. But in every case, there's always a defect.

Over the years, I've saved a lot of money by buying shop grade plywood. (It typically costs 20% to 30% less than the higher grades.) It takes a little more time poking around the stacks of plywood at the lumber store, but that's okay, I enjoy it.

## What Grade is that Plywood?

Unlike softwood plywood, hardwood plywood is generally *not* stamped to show its grade.

Why? Because the ink used for the stamp would stain the veneer. And the edge of the plywood is usually too thin. Note: Some companies stamp the edge of their thicker plywood, see photo.

If you need a particular grade, you'll have to ask for it — and rely on your supplier.

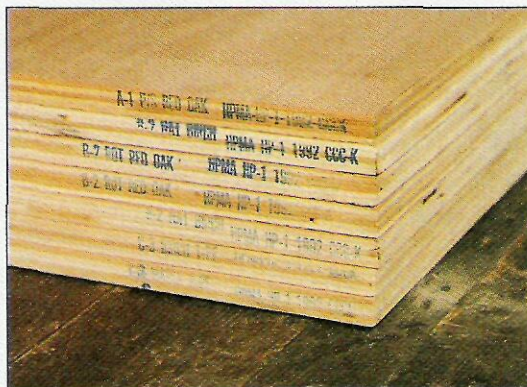

## Lumber Questions?

Identifying, selecting, and buying materials for your workshop projects can be a bit confusing.

If you have any questions about lumber or other project materials, send them to: *ShopNotes*, Attn: Lumberyard, 2200 Grand Ave., Des Moines, IA 50312.

Please include a daytime phone number so we can call you if necessary.

# Sources

*ShopNotes Project Supplies* is offering some of the hardware and supplies needed for the projects in this issue.

We've also put together a list of other mail order sources that have the same or similar hardware and supplies.

## HAND PLANE

Using a hand plane that you've made yourself is satisfying and rewarding. And the simple design of the hand plane shown on page 10 makes it easy to build your own.



The heart of the plane is a blade set manufactured by Hock, see photo above. The set is made up of a thick blade for improved stability, and a matching chipbreaker that adds rigidity to the blade as it helps reduce tear-out.

*ShopNotes Project Supplies* is offering a hardware kit for the

Hand Plane. The kit includes a 1½"-wide Hock plane blade set, washer, and socket head screw. All you need to supply is the hardwood.

**S11-6811-100** Hand Plane Hardware Kit.....\$26.50

## MITER SAW STATION

The Miter Saw Station featured on page 16 will make your miter saw safer and more accurate to use — without sacrificing any portability.

A unique design allows a pair of extension wings to knock-down and slip into the station for storage. Fence rails help position long stock and are slotted to accept a stop system. This stop system allows you to make quick and accurate repeat cuts.

*ShopNotes Project Supplies* is offering a hardware kit for the Miter Saw Station. The kit includes all the hardware needed to build the station. All you need to supply is ¾"-thick hardwood and plywood. Note: You'll also need to supply the correct size mounting bolts and T-nuts to attach your miter saw to the station.

**S11-6811-200** Miter Saw Station Hardware Kit.....\$23.95

## SHARPENING

The Sharpening with Sandpaper article shown on page 24 describes a method of sharpening that uses silicon carbide sandpaper instead of water or oil stones. The grit of the sandpaper used ranges from 240 to 2000.

Most hardware stores carry silicon carbide paper up to 600 grit. The finer grits (up to 2000) can be found at most auto body shops and supply stores. If you can't find this sandpaper locally, see the mail order sources below.

## RANDOM-ORBIT SANDERS

The article on random-orbit sanders shown on page 8 explains what makes these sanders different from other sanders, and describes how they work.

They're more aggressive than an orbital (finishing) sander. And you don't have to worry about creating cross-grain scratches if you sand across grain (or joint lines) like you do with a belt sander.

Random-orbit sanders can be found at many hardware stores and home centers. If you can't find them locally, see the mail order sources listed below.

## MAIL ORDER SOURCES

Similar hardware and supplies may be found in the following catalogs. Please call each company for a catalog or for ordering information.

### Constantine's

800-223-8087  
Honing Guides, Random-Orbit Sanders, 1200 Grit Sandpaper

### Garrett Wade

800-221-2942  
Honing Guides, 1200 and 1500 Grit Sandpaper

### Highland Hardware

800-537-7820  
Honing Guides, Random-Orbit Sanders

### Japan Woodworker

800-537-7820  
Hock Plane Blades, Honing Guides

### Sanding Catalogue

800-228-0000  
Random-Orbit Sanders, 800, 1000, and 1200 Grit Sandpaper

### Trendlines

800-767-9999  
Random-Orbit Sanders

### Woodcraft

800-225-1153  
Honing Guides, Random-Orbit Sanders

### The Woodworkers' Store

612-428-3200  
Honing Guides, Random-Orbit Sanders

### Woodworker's Supply

800-645-9292  
Honing Guides, Random-Orbit Sanders

## ORDER INFORMATION

### BY MAIL

To order by mail, use the order form that comes with the current issue. The order form includes information on handling and shipping charges, and sales tax.

If the mail order form is not available, please call the toll free number at the right for more information on specific charges and any applicable sales tax.

### BY PHONE

For fastest service use our Toll Free order line. Open Monday through Friday, 7:00 AM to 7:00 PM Central Time.

Before calling, have your VISA, MasterCard, or Discover Card ready.

**1-800-444-7527**

Note: Prices subject to change after November 1, 1993.



## Scenes From the Shop

Often referred to as a "transitional" plane, this Stanley No. 35 features a cast iron frame with an accurate blade setting mechanism. And a wooden sole that many pre-

ferred (over all-metal planes) for the better "feel" it provided when planing. And to protect their investment, the owner often stamped their name on one end.