

TIPS • TOOLS • TECHNIQUES

ShopNotes®

Vol. 3

Issue 13



Build Your Own **DUST COLLECTOR**

- Router Bit Storage Cabinet
- Scroll Saw Blades
- Band Saw Blade Set-Up
- Six Shop-Tested Tips



ShopNotes®

Issue 13 January 1994

- EDITOR** Donald B. Peschke
EXECUTIVE EDITOR Douglas L. Hicks
MANAGING EDITOR Terry J. Strohman
ASSOCIATE EDITOR Richard S. Peters
ASSISTANT EDITOR Tim Robertson
CONTRIBUTING EDITOR Philip A. Totten
- CREATIVE DIRECTOR** Ted Kralicek
ART DIRECTOR Cary Christensen
SENIOR ILLUSTRATOR Kurt Schultz
ILLUSTRATORS Will Niskanen
 Roger Reiland
 Mark Higdon
PHOTOGRAPHER Crayola England
- DESIGN DIRECTOR** Ken Munkel
SENIOR DESIGNERS Jan Hale Svec
 Kent Welsh
SHOP MANAGER Steve Curtis
SHOP ASST./FACILITIES Steve Johnson

CIRCULATION

Circulation Director: Liz Bredeson • *Subscription Manager:* Phyllis Jessen • *Circulation Analyst:* Rod Cain • *Newsstand Sales:* Kent A. Buckton

PUBLISHING SERVICES

Associate Editor: Gordon C. Gaippe • *Sr. Graphic Designer:* Robert H. Whitmer • *Graphic Artist:* Cheryl L. Cynor

CORPORATE SERVICES

Controller: Robin Hutchinson • *Accounting:* Laura Thomas • *Bookkeeping:* Julie Greenlee • *Info. Services Manager:* Joyce Moore • *Elect. Pub. Coordinator:* Douglas M. Lidster • *Admin. Assistants:* Cheryl Scott, Julia Fish • *Receptionist:* Jeanne Johnson • *Building Maint.:* Ken Griffith

PROJECT SUPPLIES

Marketing Director: Robert Murry • *Catalog Art Director:* Cindy Jackson • *Fulfillment Manager:* Valerie Wiese • *Catalog Products Manager:* Bob Baker • *Project Supplies:* Linda Jones • *Technical Support:* Jeff Janes • *Application Specialist:* Linda Morrow • *Receptionist:* Cynthia Kerman

CUSTOMER SERVICE

Supervisor: Jennie Enos • *Customer Service Representatives:* Jennifer Murphy, Joy Johnson, Sara Kono, Ami Blanshan, Anna Cox, Tammi Aldini, Kristi Andrews, Stephanie Hagen

SHIPPING DEPARTMENT

Supervisor: Jerry Carson • *Fulfillment:* Gloria Sheehan, Don McVey, Chuck Carlson, Sylvia Carey

ShopNotes® (ISSN 1062-9696) is published bimonthly (Jan., March, May, July, Sept., Nov.) by Woodsmith Corporation, 2200 Grand Ave., Des Moines, IA 50312. ShopNotes® is a registered trademark of Woodsmith Corp. ©Copyright 1994 by Woodsmith Corporation. All rights reserved.
Subscriptions: Single Copy, \$4.95. One year subscription (6 issues), \$19.95. Two years (12 issues), \$35.95. Canada/Foreign, add \$5.00 per year.
Second Class Postage Paid at Des Moines, IA and at additional offices.
Postmaster: Send change of address to ShopNotes, Box 11204, Des Moines, IA 50340-1204
Subscription Questions? Call 1-800-333-5854, 8am to 5pm, Central Time, weekdays.

PRINTED IN U.S.A.

EDITOR'S NOTE

Sawdust. It's a problem for every woodworker I know. It can cause health problems. It clogs up machinery. And it eventually covers everything in the shop (and often the rest of the house) with a fine layer of dust.

For years, professional woodworking shops have used specially designed collection systems to deal with sawdust. Unfortunately, these systems are too large and too expensive for most home workshops.

DUST COLLECTION SYSTEM. So we decided to design a smaller shop-built version of a professional system. (For more on this, see page 14.) Like a professional system, our version uses a special canister (cyclone) to separate the large chips from the fine dust.

But instead of buying an expensive all-metal cyclone, we built our own. It's a hybrid — part wood, part metal. The woodworking part was easy. However when it came time to making the sheet

metal parts, I was a bit apprehensive. (I should have paid more attention in my eighth grade metal shop class.)

SHEET METAL. But armed with a pair of tin snips and a pair of gloves, I decided to try it once again. I soon found that working with sheet metal wasn't difficult. In fact, much of it was similar to woodworking. Careful layout and planning. And a bit of patience when cutting. That's all it takes regardless of the material — metal or wood.

PUBLISHER'S STATEMENT. As you may have noticed, the bottom half of this page is filled with an official looking document. Every year the post office requires we print a Publisher's Statement. It lets them know the number of issues we send out and where they go.

The good news is that we're still growing. The average single issue circulation is up 129,000 from last year. Thank you. Without your support this growth would not be possible.

STATEMENT OF OWNERSHIP, MANAGEMENT AND CIRCULATION (Required by 39 U.S.C. 3685)

1. Title of Publication: ShopNotes. 1a. Publication No.: 10629696. 2. Date of Filing: September 22, 1993. 3. Frequency of issue: Bimonthly. 3a. No. of issues published annually: 6 (six). 3b. Annual subscription price: \$19.95. 4. Complete mailing address of known office of publication: 2200 Grand Avenue, Des Moines, (Polk County), Iowa 50312-5306. 5. Complete mailing address of the headquarters of general business offices of the publisher: 2200 Grand Avenue, Des Moines, Iowa 50312-5306. 6. Full names and complete mailing address of publisher, editor, and managing editor: Publisher and Editor: Donald B. Peschke, 2200 Grand Avenue, Des Moines, Iowa 50312; Managing Editor: Terry J. Strohman, 2200 Grand Avenue, Des Moines, Iowa 50312. 7. Owner: Woodsmith Corporation, 2200 Grand Avenue, Des Moines, Iowa 50312; Donald B. Peschke, 2200 Grand Avenue, Des Moines, Iowa 50312. 8. Known bondholders, mortgagees, and other security holders owning 1 percent or more of total amount of bonds, mortgages or other securities: None. 9. (Does not apply.) 10. Extent and nature of circulation:

	Average no. copies each issue during preceding 12 months	Average no. copies of single issue published nearest to filing date
A. Total no. copies printed (net press run)	279,983	305,000
B. Paid and/or requested circulation:		
1. Sales through dealers, street vendors and counter sales	14,745	22,151
2. Mail subscriptions (paid and/or requested)	239,600	272,490
C. Total paid and/or requested circulation	254,345	294,641
D. Free distribution by mail, carrier or other means, samples, complimentary, and other free copies	25	20
E. Total distribution	254,370	294,661
F. Copies not distributed		
1. Office use, left over, unaccounted, spoiled after printing	13,941	9,467
2. Returns from news agents	11,672	872
G. Total	279,983	305,000
11. I certify that the statements made by me above are correct and complete. (signed) Donald B. Peschke, Publisher/Editor		

Contents

Router Bit Storage Cabinet _____ 4

You can both protect and organize your router bits by building this handy storage cabinet.

Scroll Saw Blades _____ 8

A look at the different types, styles, and sizes of blades that give the best results when using a scroll saw.

Band Saw Set-Up _____ 10

Changing the blade on a band saw is easy when you follow these step by step instructions. We'll take you through tracking, tensioning, and adjusting the blade guides.

Dust Collection System _____ 14

This shop-made dust collector features a two-stage system. The first stage removes large chips. And the second stage filters out fine dust particles.

Cyclone _____ 15

Plywood and metal flashing combine to make the first stage of the dust collector — a cyclone that funnels large chips into a roll-around chip bin.

Filter Box _____ 22

By wrapping an inexpensive fabric around a simple frame, you can form the second stage of the dust collection system which filters out fine dust particles.

Pipe & Hook-Ups _____ 24

All it takes to connect your power tools to our dust collector or your existing collector is a system of pipes and these shop-built hook-ups.

Shop Solutions _____ 28

Six Shop-Tested Tips: Toggle Clamp Stop Block, Shop-Made Utility Knife, Measurement Tip, a Tip for Rubbing Out a Finish, Sawhorse with Insert, and a Tip for Installing a Strike Plate.

Plywood Veneers _____ 30

The appearance and cost of a sheet of plywood can vary greatly depending on how the face veneer is cut.

Sources _____ 31

Hardware, project supplies, and mail order sources for the projects in this issue.

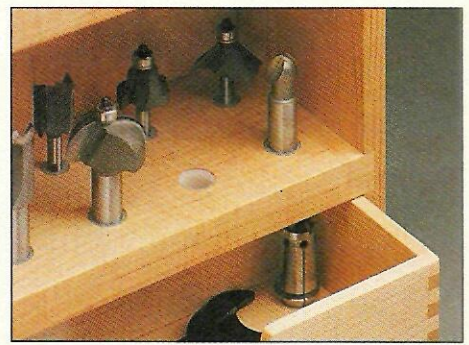

Router Bit Storage page 4

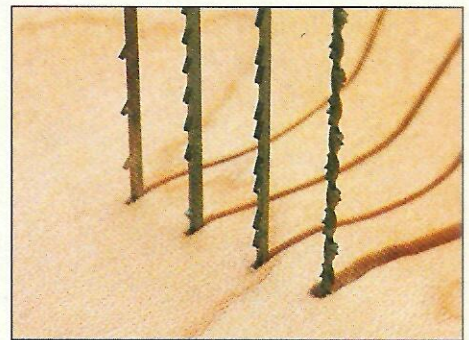

Scroll Saw Blades page 8

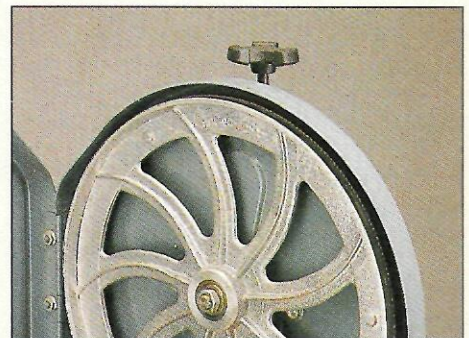

Band Saw Set-Up page 10

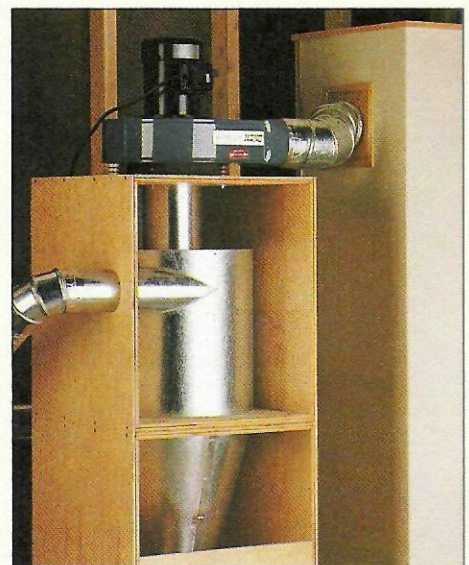

Dust Collector page 14

Router Bit Storage Cabinet

Protect and organize your router bits with this sturdy storage cabinet. It features a unique bit holding system and a handy pull-out drawer.

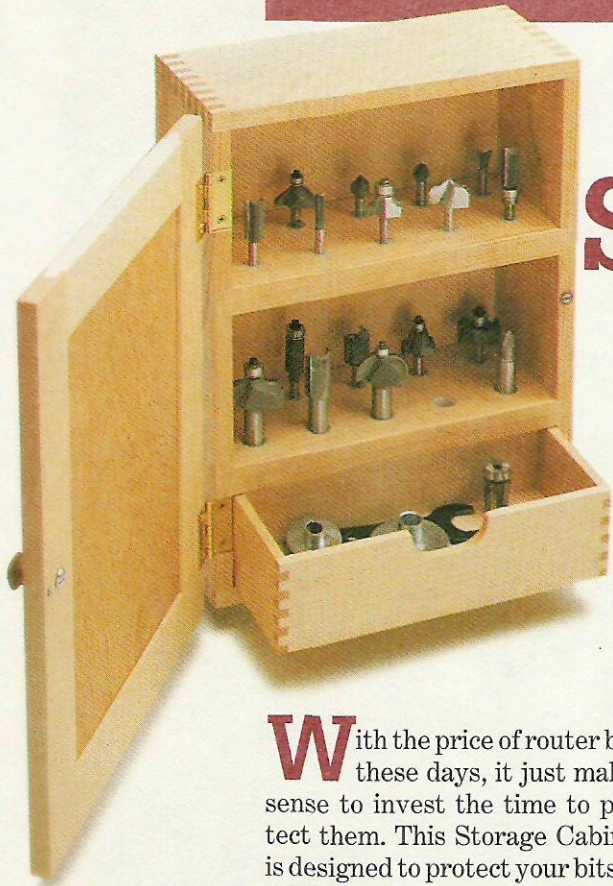

With the price of router bits these days, it just makes sense to invest the time to protect them. This Storage Cabinet is designed to protect your bits—and keep them organized too.

To keep from nicking sharp cutting edges, the bits are spaced apart and held upright in a pair of shelves, see photo. There's even a unique system to hold the bits. (For more on this, see page 5.)

This cabinet also has a door to keep the bits clean and free from dust and dirt. And I added a pull-out drawer inside the cabinet to store and protect large bits, wrenches, and other accessories.

THE CASE

I started work on the Storage Cabinet by making the case. It's just a shallow box consisting of two *sides* (A) and a *top/bottom* (B), see Fig. 1. I cut these pieces from 1/2"-thick stock and used box joints for them to hold them together, see Figs. 1 and 1a. (If you haven't made box joints before, you can find information and plans for a jig in *ShopNotes* No. 8.)

SHELF DADOES. Once the box

joints are cut, dados are cut in the sides for the shelves that hold the bits, see Fig. 1. These dados are 3/4"-wide and cut across the full width (depth) of the sides.

BACK. Next, to seal up the rear of the cabinet, I added a *back* (C), see Fig. 1. It's just a piece of 1/4"-thick plywood that fits into 1/4" x 1/4" grooves cut in the sides and top/bottom pieces, see Fig. 1b.

ASSEMBLY. With the back cut to size, the case can be glued and clamped together. When the glue dries, you'll need to plug the small square holes in the top and bottom of the cabinet left from cutting the grooves in the sides. (For detailed instructions on how to do this, see page 6.)

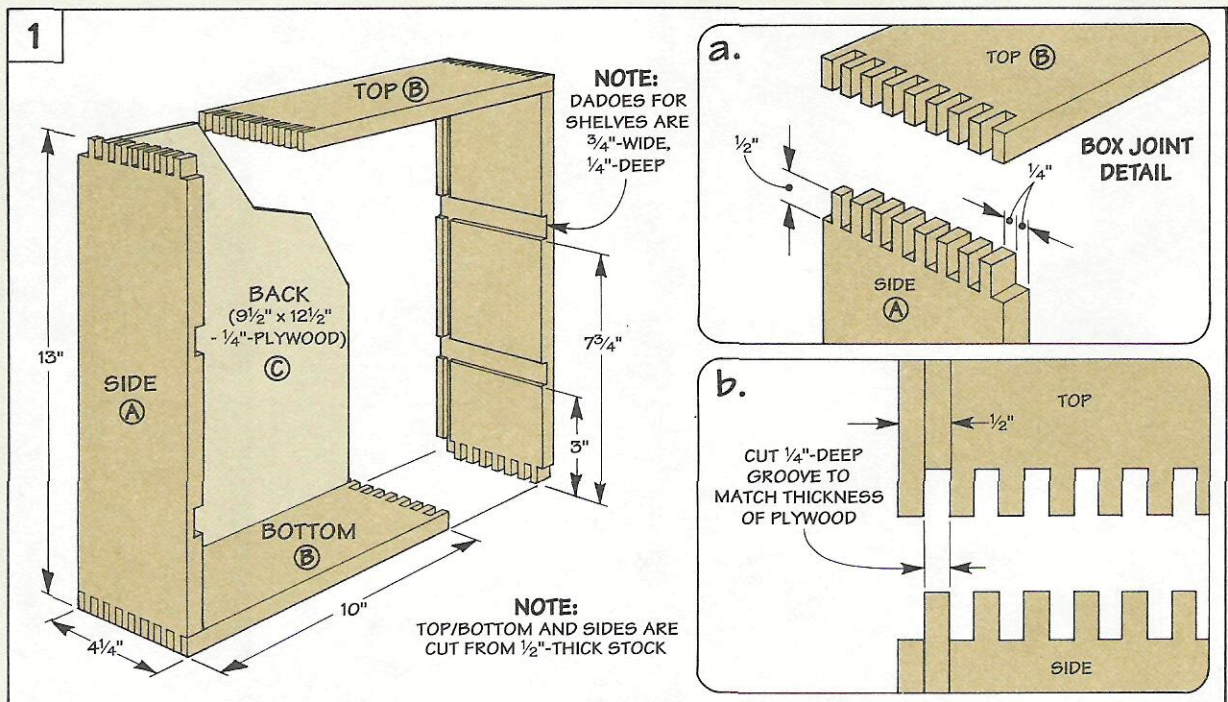

Shelves

After the case is assembled, the next step is to make the shelves that hold the router bits. These shelves fit into the dados you cut earlier in the case sides.

CUT TO FIT. The shelves (D) are cut to length from 3/4"-thick stock to fit between the sides. As for the width, trim them so they end up flush with the front edge, see Fig. 2. (In my case, they're 3 3/4" wide and 9 1/2" long.)

BIT HOLES. After cutting the shelves to size, the holes for the router bits can be laid out, see Fig. 2b. But there's a problem here. If you just drill holes in the shelves and insert a bit, you may not be able to get it out. That's because humidity can cause the wood to swell and "lock" it in place.

SLEEVES. To prevent this from happening, I used nylon sleeves, see photo below. They're just nylon spacers I found at a local hardware store. Since the nylon doesn't swell up like wood does, your router bits will always slip in and out easily.

TWO SIZES. Although the layout for the holes in the shelves is the same (see Fig. 2b), the diameter of the holes may be different.

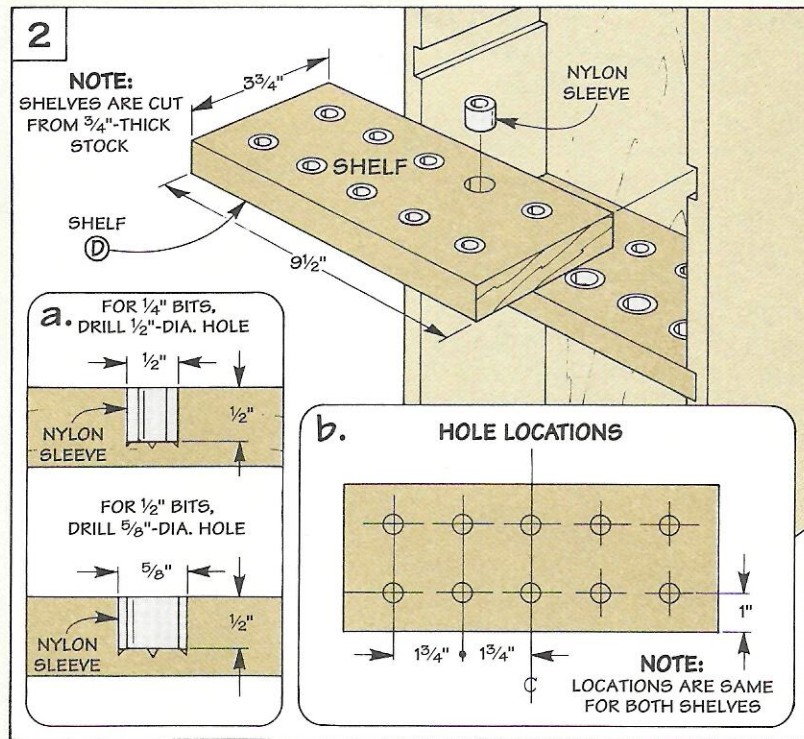

The size of each hole is determined by the shank size of the router bit, see Fig. 2a.

If you have 1/4"-shank bits, you'll need to drill 1/2"-dia holes, see Fig. 2a. If they're 1/2"-shank bits, drill 5/8"-dia. holes. Note: Before you drill, it's a good idea to first buy the nylon sleeves you'll

need. (A hardware kit is available, see Sources on page 31.)

ASSEMBLY. Once the holes are drilled, the next step is to glue in the nylon sleeves. To do this, I squirt "instant" glue in each hole and insert a sleeve. Then to complete the case, glue and clamp the shelves flush with the front edge.

Materials

- | | |
|----------------------|-------------------------------|
| A Sides (2) | 1/2 x 4 1/4 - 13 |
| B Top/Bottom (2) | 1/2 x 4 1/4 - 10 |
| C Back (1) | 9 1/2 x 12 1/2 - 1/4 plywood |
| D Shelves (2) | 3/4 x 3 3/4 - 9 1/2 |
| E Drawer Ft./Bk. (2) | 1/4 x 2 1/2 - 8 15/16 |
| F Drawer Sides (2) | 1/4 x 2 1/2 - 3 3/4 |
| G Drawer Bottom (1) | 3 1/2 x 8 11/16 - 1/4 plywood |
| H Door Stiles (2) | 1/2 x 1 1/2 - 13 |
| I Door Rails (2) | 1/2 x 1 1/2 - 7 3/4 |
| J Door Panel (1) | 7 3/4 x 10 3/4 - 1/4 plywood |
| K Cabinet Cleat (1) | 1/4 x 2 1/2 - 9 |
| L Wall Cleat (1) | 1/4 x 2 1/2 - 8 15/16 |
- (1) 3/4"-dia. Wood Knob w/screw
 - (1) 5/16"-dia. Magnetic Catch w/screw
 - (2) 1 1/2" x 1 1/4" Brass Hinges w/screws
 - 1/4" ID, 1/2"-long Nylon Spacers
 - 1/2" ID, 1/2"-long Nylon Spacers

Nylon Sleeves

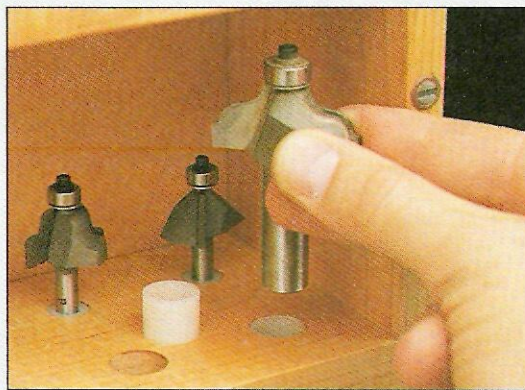

To make it easy to slip bits in and out, nylon sleeves fit into holes drilled in each shelf. This way when the humidity changes, the wood can't swell and "lock" the bits in place.

Drawer

After completing the case, I added a small drawer that slides into the bottom opening of the case, see Fig. 3. This makes a handy place to store larger bits, wrenches, and other accessories.

BOX JOINTS. The drawer is made up of a front and back (E) and two sides (F), see Fig. 3. Here again I used box joints. But since the drawer pieces are cut from 1/4"-thick stock, the box joints are 1/4" x 1/4" (instead of 1/4" x 1/2" as with the case), see Fig. 3a.

DRAWER PIECES. To find the height (width) of all the drawer pieces, measure the height of the opening (2 1/2"). Normally at this point I would subtract a 1/16" for clearance. But this would mess up the 1/4" spacing for the box joints. So instead, I cut the pieces to full height (2 1/2"). And then sanded the drawer to fit the opening after it was assembled.

To determine the length of the front and back (E) pieces, measure the width of the drawer opening and subtract 1/16" for clearance (8 15/16"), see Fig. 3. Next, since I wanted the drawer to be flush with the front of the case, the sides (F) are cut to match the depth of the opening (3 3/4").

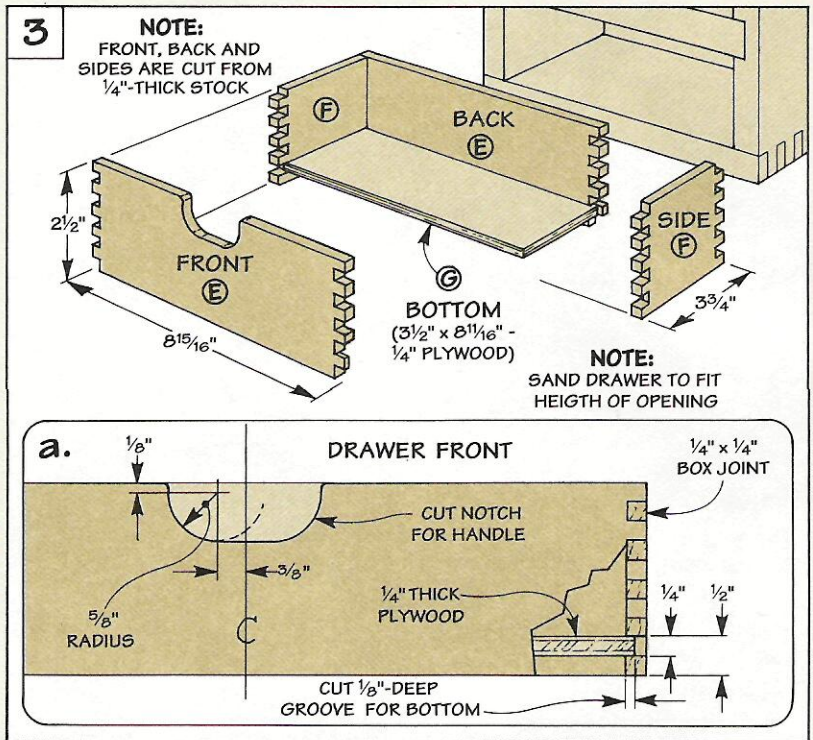

NOTCH. To make a simple "handle" for the drawer, I cut a centered notch in the top edge of the drawer front, see Figs. 3 and 3a. Once this notch is cut out, box joints can be cut to join the drawer pieces together, see Fig. 3a.

BOTTOM. The next step is to cut 1/8"-deep grooves in all the drawer pieces for a 1/4"-thick bot-

tom (G), see Figs. 3 and 3a. Here again, you'll need to plug these holes after you've glued up the drawer, refer to box below.

TEST FIT. After filling the holes, test the fit of the drawer in the case. If necessary, sand the top or bottom edges of the drawer to achieve a fit that's snug but still slides in and out without binding.

Hiding the Groove in a Box Joint

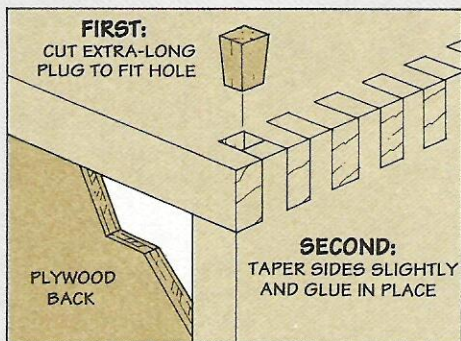

Step 1: Plug the hole. Start by cutting an extra-long square plug to fit the hole. Then taper the sides slightly to get a snug fit, and glue the plug in place.

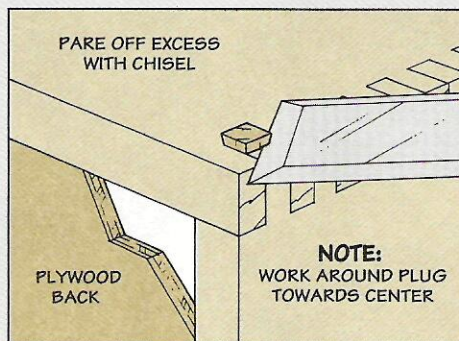

Step 2: Trim the plug. After the glue has dried, use a chisel to pare off excess by working around the plug towards the center. Then sand it smooth.

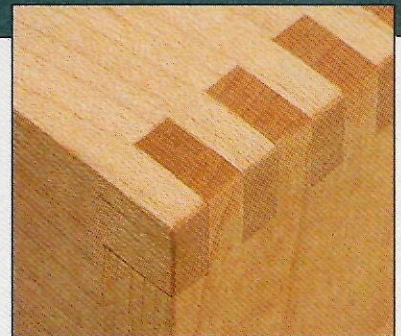

▲ Whenever you cut a full-length groove in project with box joints, you'll end up with a small square hole. But you can fill this with a small end grain plug and make the hole virtually disappear.

Door

With the drawer complete, the next thing is to add a door to keep your router bits free from dust and dirt. The door is just a hardwood frame that fits around a plywood panel, see Fig. 4.

FRAME PIECES. All the frame pieces are the same width (1½"). The only difference is their length. The *stiles* (H) are 13" long. And the *rails* (I) are 7¾" long.

STUB TENON & GROOVE. The frame (and panel) is held together with a simple joint — a stub tenon and groove. A ⅜"-deep, ¼"-wide groove is cut centered in each piece, see Fig. 4a. This groove accepts a ¼"-thick plywood *panel* (J). And it also serves as the mortise for the short (stub) tenons cut on the ends of the rails, see Figs. 4 and 4a.

ASSEMBLY. After the stub tenons are cut, the door can be glued and clamped up. When the glue is dry, you can mount the door on the case. It attaches to one side with a pair of hinges, see Fig. 5.

Note: The hinge mortises are cut in the case to match the thickness of *one* hinge flap. This leaves about ⅛" clearance between the door and the case for a magnetic catch that's added later.

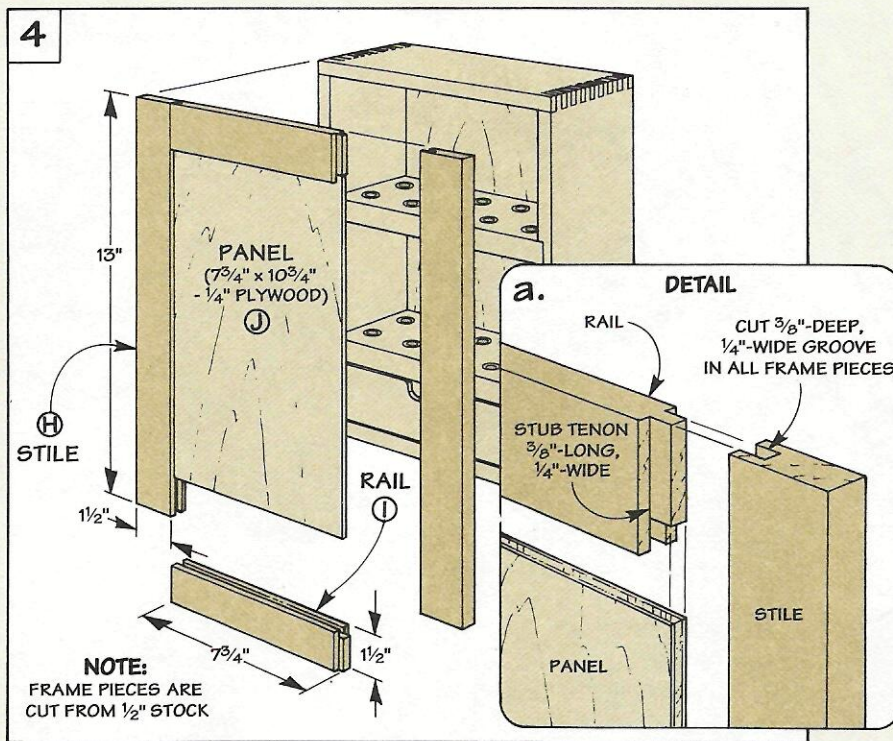

With the door in place, the next step is to add a knob and a magnetic catch, see Fig. 5a. To keep the gap between the door and case to a minimum, I used a No. 4 x ⅜" flathead woodscrew instead of the thick strike plate that comes with the catch, see Fig. 5a. It still provides plenty of "pull" and can be easily adjusted in or out.

HANGING SYSTEM. Finally, to mount the case to a wall, I used a unique two-piece system, see Fig. 5b. A *cabinet cleat* (K) is glued to the back of the case. And a *wall cleat* (L) is screwed to the wall. The advantage of this system is it allows you to lift off the cabinet and take it wherever you need it in the shop.

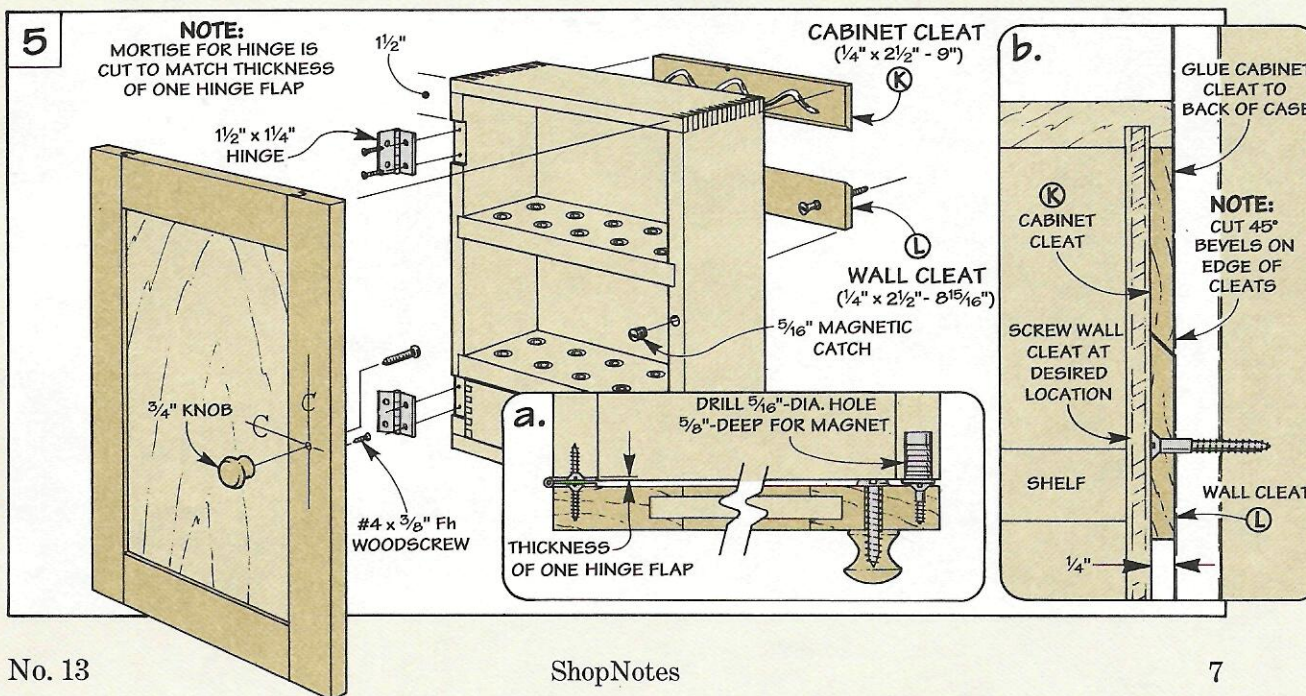

Scroll Saw Blades

At first glance, all scroll saw blades look the same. But there's a big difference in how they perform. The trick is to match the type, style, and size of the blade to the job.

TYPES

Scroll saw blades come in two basic types — pin end and plain end, see Fig. 1. The type you use will depend on your saw.

PIN END. A *pin end* blade is held in place by two small metal pins at each end. This makes it possible to quickly change blades without using a wrench or a screwdriver. To make room for the pin, these blades are wider than plain end blades, see Fig. 1. This extra width is useful whenever you need to cut along a straight line or a gradual curve.

PLAIN END. *Plain end* blades slip into slotted clamp heads. Then a screw or bolt is tightened to pinch the blade in place. Since

there's no pin, these blades can be manufactured in very narrow widths. This is a big advantage when you're cutting tight curves or intricate patterns.

STYLES

The type of blade you use (pin or plain end) depends on your saw. But the *style* of blade you choose is up to you. There are basically five styles to choose from.

"I've found that the number 5, 7, and 9 size blades will handle 90% of most scroll saw jobs."

All of these styles are modifications of the traditional scroll blade style. These blades have evenly spaced teeth like a hand saw, see Fig. 2. And for years this style of blade was all I used.

But now manufacturers are producing blades with a wide variety of tooth shapes and spacing patterns. After experimenting

with the different styles, I've found that each offers one or more advantages over the traditional blades. For more on this, see the opposite page. (Mail-order sources of scroll saw blades can be found on page 31.)

SIZES

In addition to the style of the blade, you'll also need to pick a specific *size* blade to use. The size of a scroll saw blade is determined by its width, thickness, and the number of teeth per inch.

Most blades are sized according to a numbering system that ranges from 0 to 12. Basically, the higher the number, the fewer the teeth. And the fewer the teeth, the coarser the cut will be.

Although each size blade is designed to cut materials of different thicknesses (see box below), I've found that the number 5, 7, and 9 size blades will handle 90% of most scroll saw jobs.

What size blade should I use?

- **Veneer:** I use blade sizes 1 through 3 when cutting veneer or other thin stock. The high number of teeth (25 to 20 per inch) produces a clean cut with minimal chipout.
- **1/4"-thick or less:** As the material gets thicker, I move up to a less fragile blade with fewer teeth. Here, I use numbers 4 through 6 that range from 18 to 15 teeth per inch.
- **Stock up to 3/4" thick:** The blades I use most often are the numbers 7 through 9. These heavier blades break less, yet the teeth (around 14 per inch) still leave a smooth cut.
- **Stock thicker than 3/4":** When I cut thick stock, I switch to numbers 10 through 12 (around 12 teeth per inch). These blades also work well for gradual curves or straight cuts.

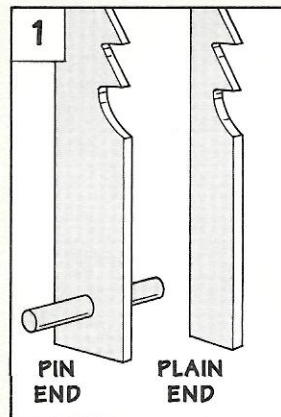

▲ Scroll saw blades have either pinned or plain ends. The type you use will depend on your saw.

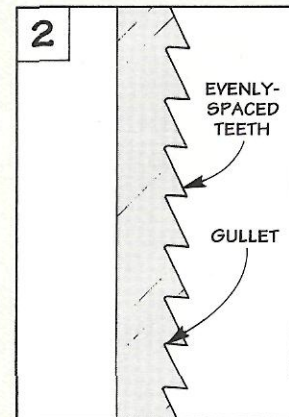

▲ The traditional scroll blade has evenly spaced teeth that point down when mounted in a saw.

Blade Styles

Skip Tooth

Skip tooth blades are the most commonly used style of scroll saw blade. They're available in either pin end or plain end.

As the name implies, every other tooth on the blade is skipped (missing). This creates a deep gullet between each tooth and provides more room for sawdust to be carried out of the kerf.

The faster the sawdust is removed from the blade, the faster you can cut, and the cooler the blade will be. The end result is a blade that lasts longer.

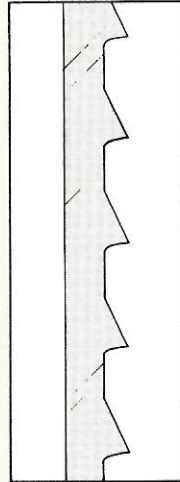

Double Tooth

The double tooth style blade is similar to a skip tooth blade. The difference is the tooth pattern.

Instead of every other tooth being skipped, these blades have two teeth in a row, then a space, and so on. This pattern combines the smooth cut of a scroll blade and the faster cutting ability of a skip tooth blade.

The additional teeth create a very smooth cut with little tear-out. I like to use this style blade whenever I work with very thin stock (such as veneer).

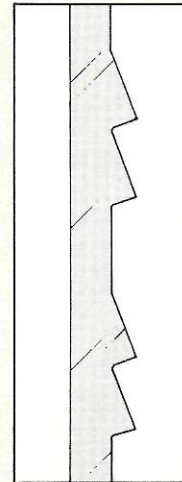

Reverse Tooth

With a name like reverse tooth, you'd expect all the teeth on this blade to be reversed. But that's not the case.

It's only the last few teeth near the bottom of the blade that are reversed (point up).

Reversing the last few teeth reduces splintering on the bottom side of the workpiece. This is particularly important when you're working with plywood. The thin face veneers are sheared on the upstroke by the reversed teeth which helps prevent chipout.

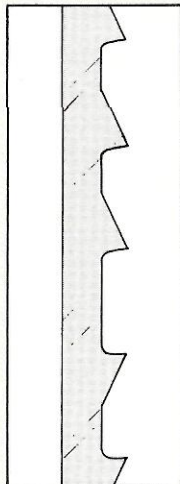

Spiral Blade

Spiral blades are just scroll saw blades that are twisted so the teeth point in different directions.

This offers two advantages. First, you can saw in any direction *without* rotating the workpiece. And second, these blades don't bow like other blades when you cut thick stock.

The only problems with these blades are they cut a wide kerf, and they tend to follow the grain direction. This means it isn't as easy to follow a pattern line as it is with the other blades.

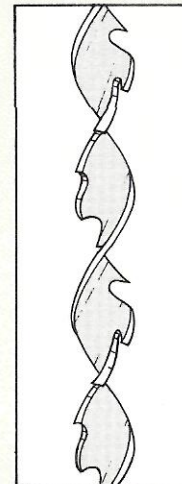

Quick Tip

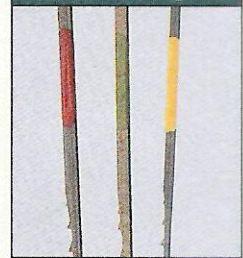

To help identify different sizes and styles of scroll saw blades, I color code the ends.

Ultra Blades

The first time I used an *Ultra* blade, I was really impressed. It cut right through a scrap of 3/4"-thick ash in seconds and left the edges satin smooth.

I found out from Ron King at Advanced Machinery Imports that the secret to this blade is the teeth. They're ground (honed) with a grinding wheel (not stamped out like other blades).

This creates very sharp teeth with a unique tooth pattern to efficiently eject sawdust from the kerf, see Drawing. Another feature of these blades is they're also reverse tooth — which means minimal chipout on the bottom of a workpiece. (For a mail-order source, see page 31.)

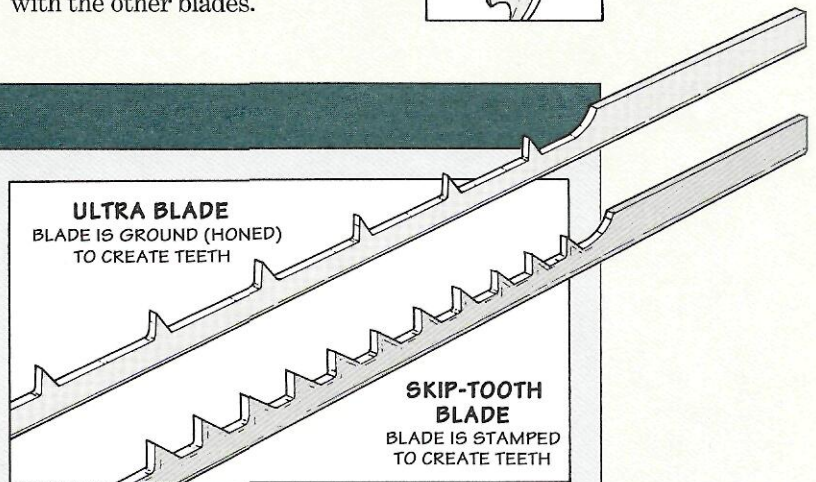

▲ To eject sawdust and create a smooth cut, the teeth on the Ultra blade (top) are spaced much farther apart than a skip tooth blade (bottom).

Band Saw Set-Up

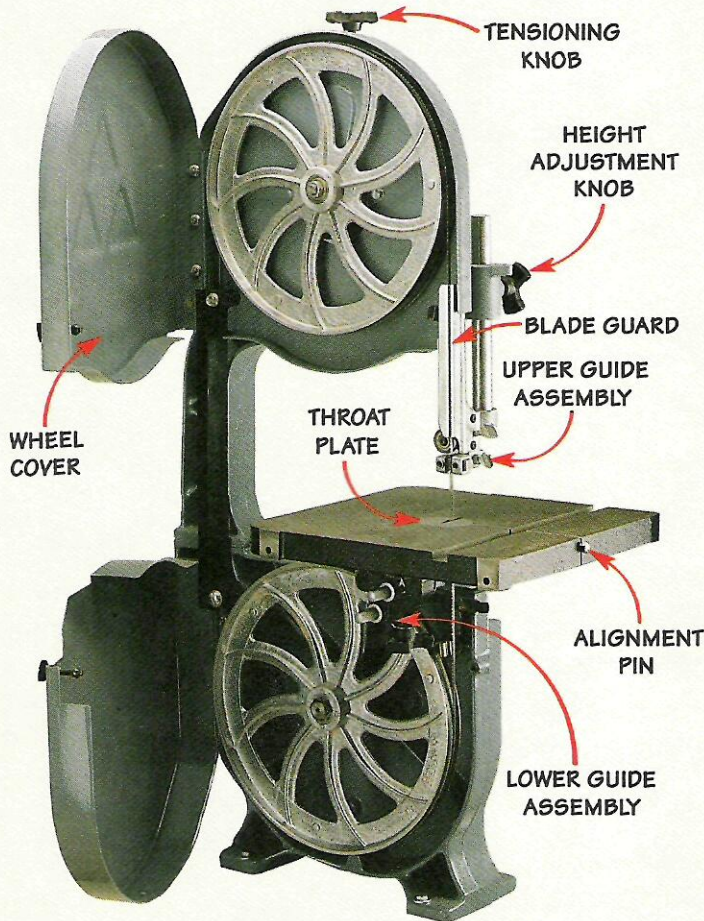

Changing a blade on the band saw doesn't have to be a chore. The secret is to break it down into simple steps. And then use the same routine everytime.

I've finally found it. A foolproof way to clear out the shop on a lazy Friday afternoon. All I have to do is suggest that someone replace the dull blade in the band saw. Within seconds, I'm all alone.

It's amazing what even experienced woodworkers will do to avoid changing a band saw blade. But changing blades doesn't have to be a chore. All it takes is a simple routine. And if you stick with this routine, it'll become second nature — just like changing the blade on a table saw.

TEN STEPS. Changing and setting up a band saw blade can be broken down into a simple ten-step routine. To make it easier to remember, we've condensed these steps and listed them in sequence in a handy reference guide, see page 13.

REMOVE THE BLADE

The first part to changing a blade in a band saw is to remove the old one. This can be broken down into three easy steps.

First, unplug the band saw and remove the guards that cover the blade, see Step 1 below. Then release the tension that stretches the blade and holds it on the band saw wheels, see Step 2 below. And finally, retract the guide assemblies which help to support the blade during a cut, and then remove the blade, see Step 3 below.

Removing a Blade

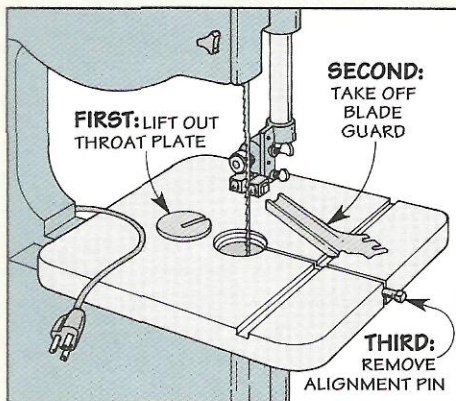

1. Remove the Guards: The first step is to remove the throat plate, the blade guard, and the pin (or fence) that aligns the two halves of the table.

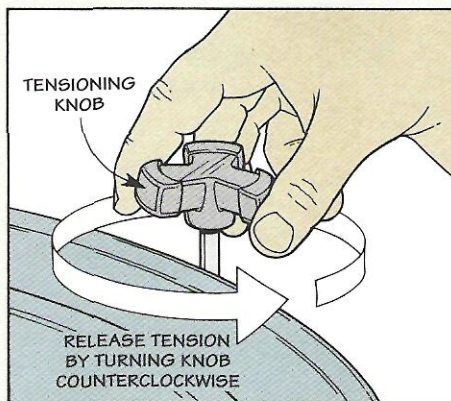

2. Release the Tension: Next, release the tension on the blade by turning the tensioning knob on top of the saw. Now you can safely take off the cover.

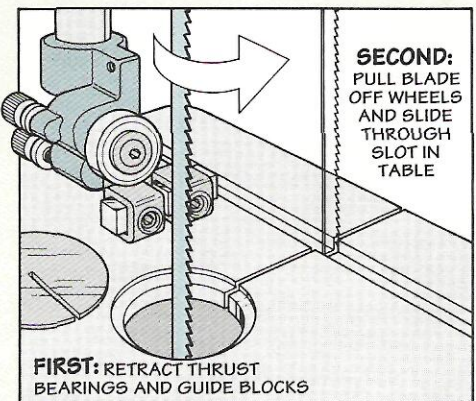

3. Retract Guide Assemblies: All that's left is to back off the upper and lower guide assemblies. Then slip the blade off the wheels and pull it out through the slot.

Installing a Blade

After the blade has been removed, the next thing I do is clean the wheels. With use, sawdust and gummy resin deposits can build up and cause the blade to shift and even come off.

CLEANING. To prevent this, I clean the rubber tires that are stretched over each wheel, see photo above. And then to keep the tires as clean as possible, I clean the blade, see photo at right.

When everything is clean, slip the blade on the wheels so it's roughly centered. And apply just enough tension to keep it in place. (Final tensioning is done later.)

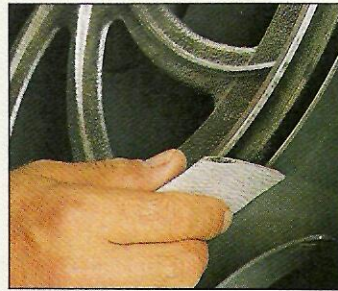

◀ **Clean the wheels:** Before you put on a new blade, scrub the wheels with denatured alcohol and a clean rag. If this doesn't get everything, try an abrasive pad (like Scotch-Brite).

◀ **Clean the blade:** It's a good idea to clean the blade before you put it on the wheels. This is especially true for new blades which are often coated with grease to inhibit rust.

TRACKING

With the blade in place, the next step is to check to see if it tracks (shifts) toward the front or rear of the wheels. To do this, turn one of the wheels a couple of times by hand, see margin tip at right. If the blade tracks true (doesn't shift), proceed to tensioning.

If it does shift, it's easy to correct. Most band saws have a tracking knob (or screw) that allows you to tilt the angle of the upper wheel, see Fig. 1. Tilt the wheel back if the blade tends to move forward. Or tilt it towards the front if it shifts backwards.

TENSIONING

Once the blade tracks true, the next step is to apply full tension. This is done by raising the upper wheel to stretch the blade, see Fig. 2. Most saws have a tension gauge which indicates an approximate setting. But I've found these indicators aren't accurate.

I usually apply more tension to a blade than the gauge suggests. When I put a 1/4" blade in my saw and tension it, the gauge reads as if it would for a 3/4" blade.

To tension a blade, slowly increase the tension and "pluck" the blade occasionally. It should ring with a clear tone, not a dull thud.



To prevent catching your finger on a sharp edge, use a length of dowel to spin the wheel.

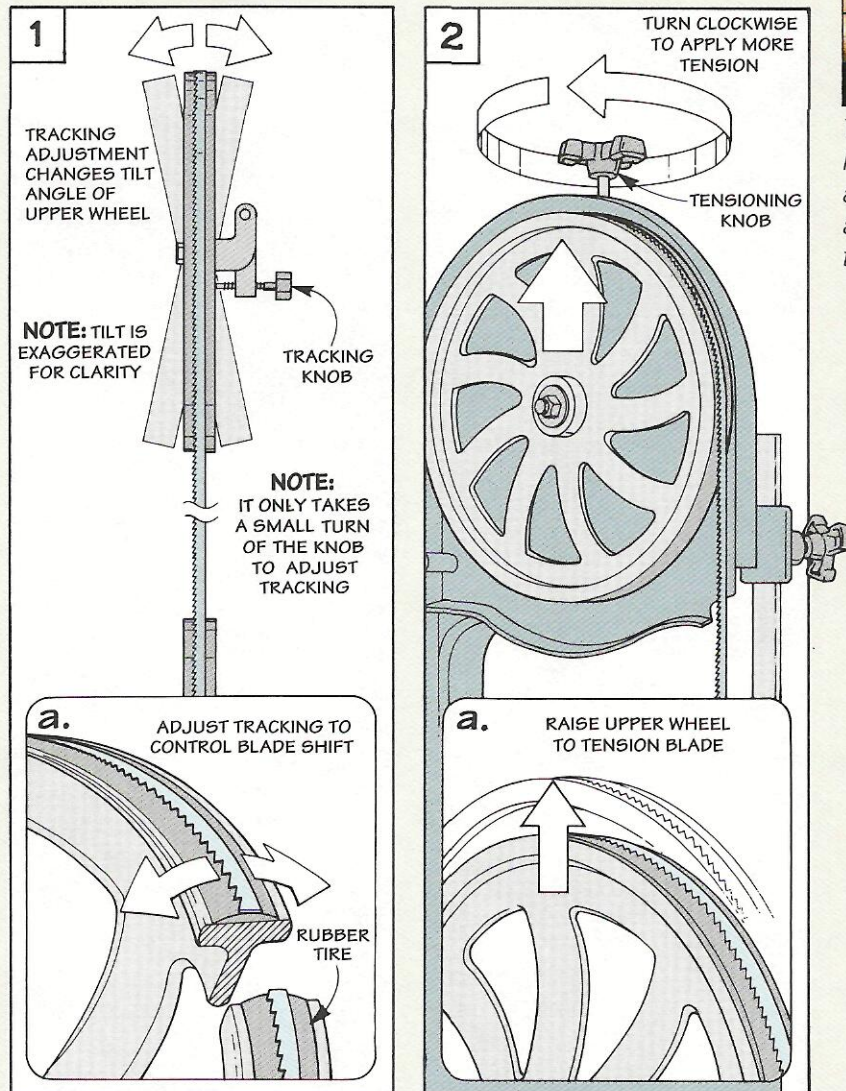

Adjusting the Guide Assemblies

Once the blade is tracking and tensioned correctly, the upper and lower guide assemblies that keep the blade on a steady path can be adjusted, see Fig. 3. Each assembly consists of a thrust bearing and a pair of guide blocks.

THRUST BEARINGS

The job of the thrust bearings is to prevent a workpiece from pushing the blade backwards as you make a cut. This way the teeth can't come in contact with the guide blocks and ruin the blade.

Adjusting the thrust bearings is simple. The idea is to position them so they are *not* touching the blade when you're not cutting (even if the saw is running), see Fig. 4a. The blade should only touch the bearings and cause them to spin when the blade flexes back during a cut.

Note: On some saws, these bearings can be adjusted with a knob. Others must be slid in or out by hand. In either case, once in position, they're locked in place with a set screw or thumbscrew.

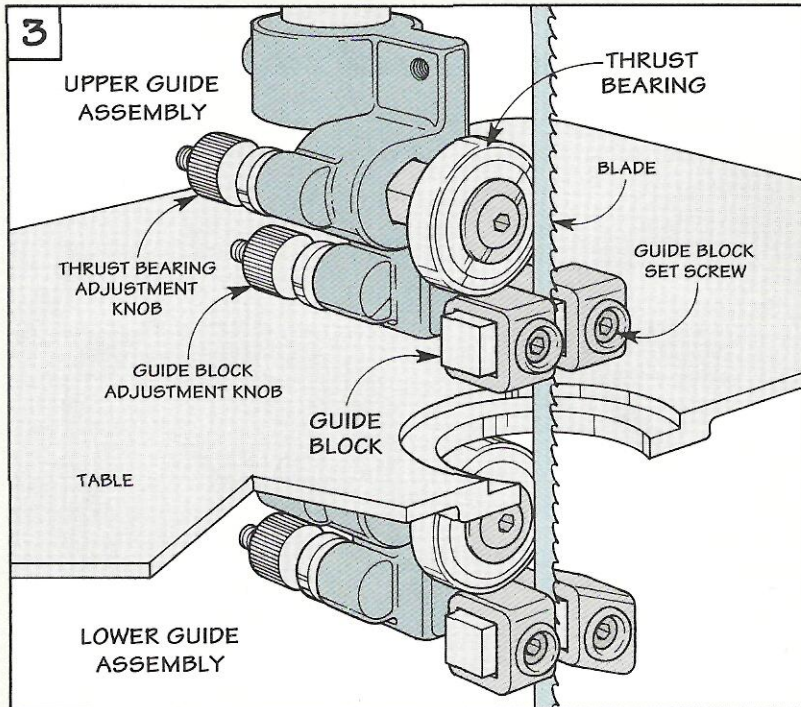

GUIDE BLOCKS

After setting the thrust bearings, the guide blocks can be positioned. These blocks help keep the blade from twisting as you make a cut.

The guide blocks are positioned in two ways: front to back and side to side. (Before you make any adjustments, it's a good idea to inspect your guide blocks for wear; see margin tip at left.)

FRONT TO BACK. For the guide blocks to do their job, they need to support as much of the blade as possible. The idea is to move them *forward* so the front edge of the block is about $\frac{1}{32}$ " behind the gullets of the teeth, see Fig. 5a. On most saws, this can be done by turning a knob at the rear of the guide assembly.

SIDE TO SIDE. The next step is to bring each guide block in close to, *but not touching* the blade. To do this, I use a piece of notebook paper as a spacer and adjust the guide blocks in pairs, see Fig. 6.

One way to do this would be to insert paper spacers on each side of the blade. Then pinch the guide blocks up against them. But this can cause a problem.

When you pinch the guide blocks together, it's easy to accidentally shift the blade slightly to the left or right. And even a small



To smooth a rough metal guide block, just rub it on a piece of silicon-carbide sandpaper.

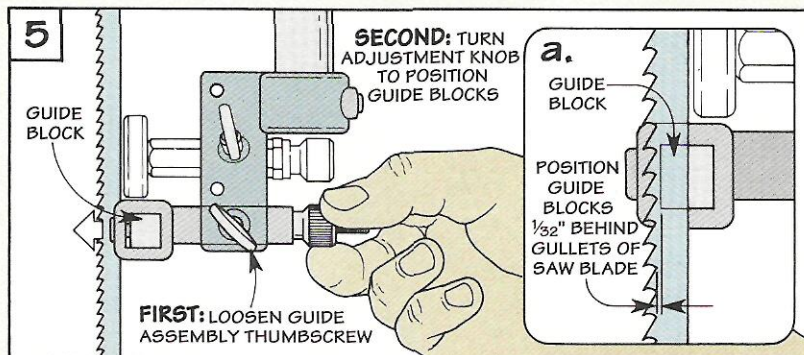
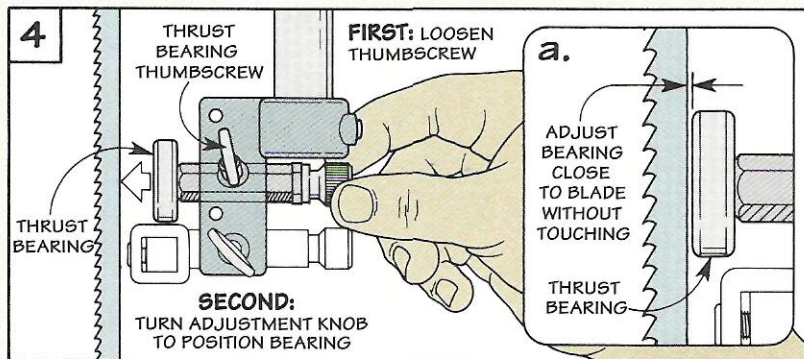

BAND SAW SET-UP STEP-BY-STEP

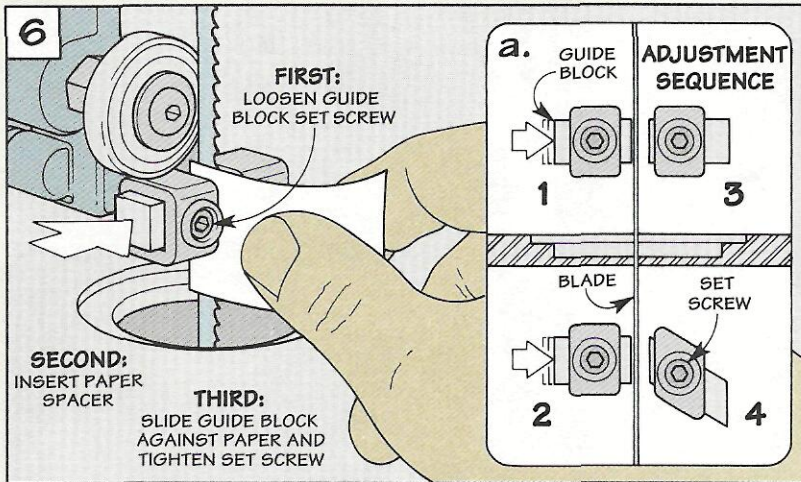

amount of offset can cause the blade to bind, overheat, and break prematurely.

ADJUST SIDES. So instead of adjusting the upper or lower guide blocks as a pair, I adjust the guide blocks on one *side* of the blade, then the other, see Fig. 6a. This way the blade doesn't get pinched and can't shift out of alignment.

To do this, loosen the set screws that hold the guide blocks on one side of the blade. Then insert a piece of paper between each block and the blade, see Fig. 6. Now slide the guide blocks over until they just touch the paper. (Make sure you don't move the blade as you do this.) Then tighten the set screws.

After you've adjusted one side, move to the other side. When you've adjusted all four guide blocks, give the wheels a couple

of turns to make sure the blade doesn't bind.

DYNAMIC TEST

At this point the saw is almost ready to test under power. But first you'll need to re-install all the safety devices. Take a moment to attach the blade guard, cover, throat plate, and table alignment pin, see Fig. 7.

Now you can plug in the saw and check to make sure the blade tracks correctly. To do this, I start by turning the saw on for just a second. If everything looks good, turn the power on and watch the blade for a couple of minutes.

If the blade doesn't wander, turn off the saw and adjust the upper blade guide assembly for a test cut, see Fig. 8. To do this, lower it as close to the workpiece as possible, but still allow enough

clearance so that you can see the cut line. Then take a cut and check that the blade just barely touches the thrust bearings as you make the cut.

1 Remove the throat plate, the blade guard, and the table alignment pin (or fence).

2 Release the tension on the blade by loosening the tension knob. Then remove the covers of the saw.

3 Back off the thrust bearing and guide blocks on both the upper and lower guide assemblies.

4 Remove the old blade. Then clean the rubber tires on the wheels and clean the new blade.

5 Install a new blade so it's roughly centered on the tires. Then apply tension to keep it in place.

6 Adjust the tracking to keep the blade from shifting to the front or back of the wheels.

7 Increase the tension slowly until the blade produces a crisp, clear tone when "plucked."

8 Position the thrust bearings just slightly away from the back of the blade and lock them in place.

9 Adjust the guide blocks to support the blade from side to side and keep it from wandering.

10 Install the safety devices you removed in Step 1 and then make a test cut on a scrap of wood.

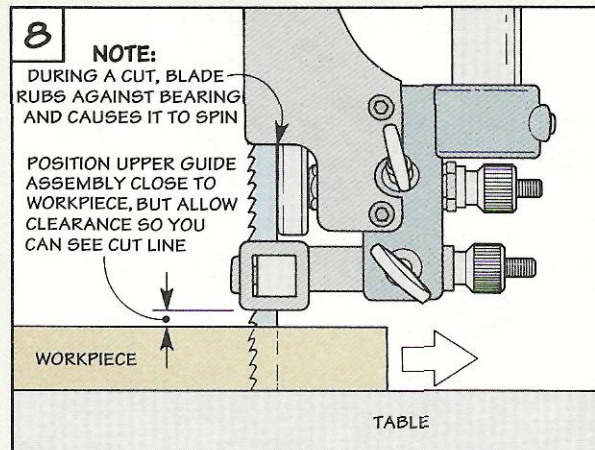
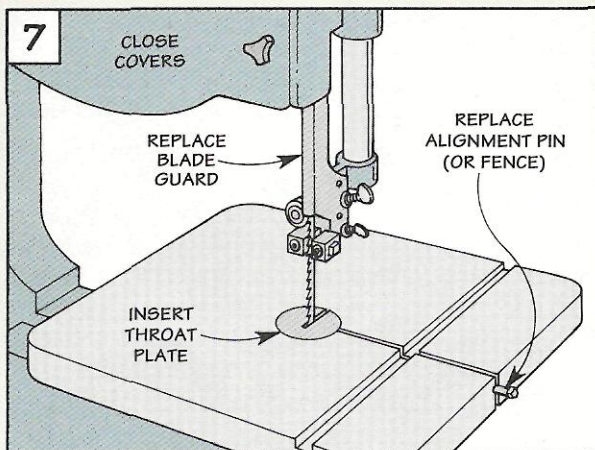

Dust Collection System

Spend more time making sawdust and less time cleaning it up with this shop-built dust collection system.

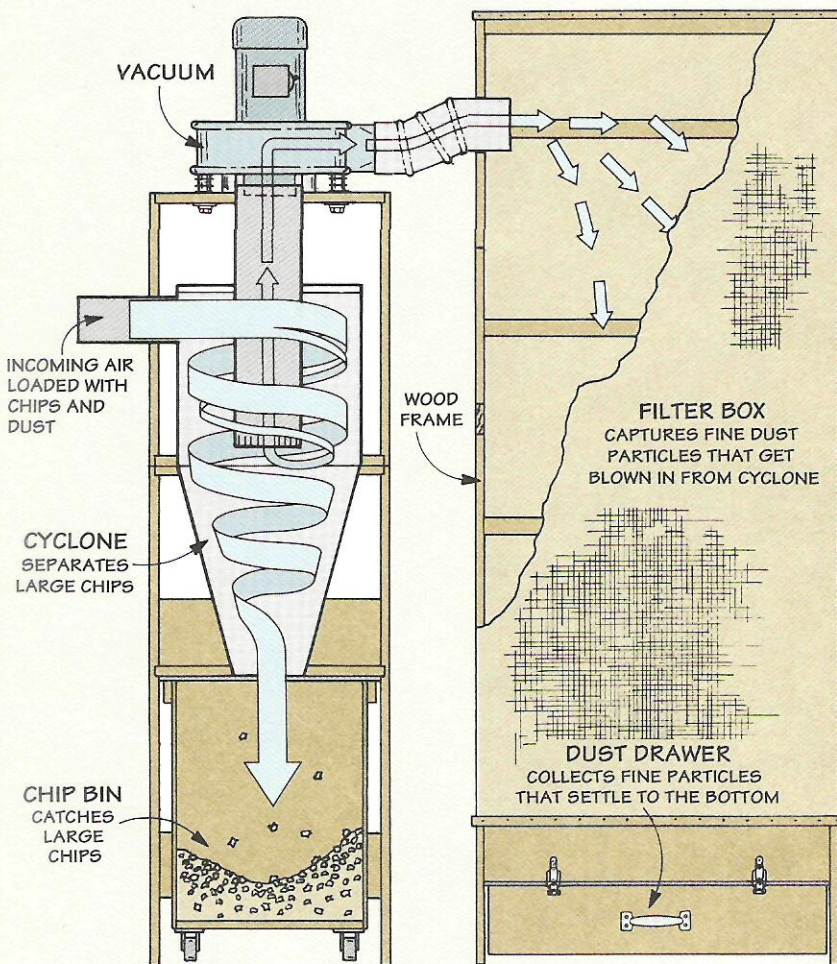
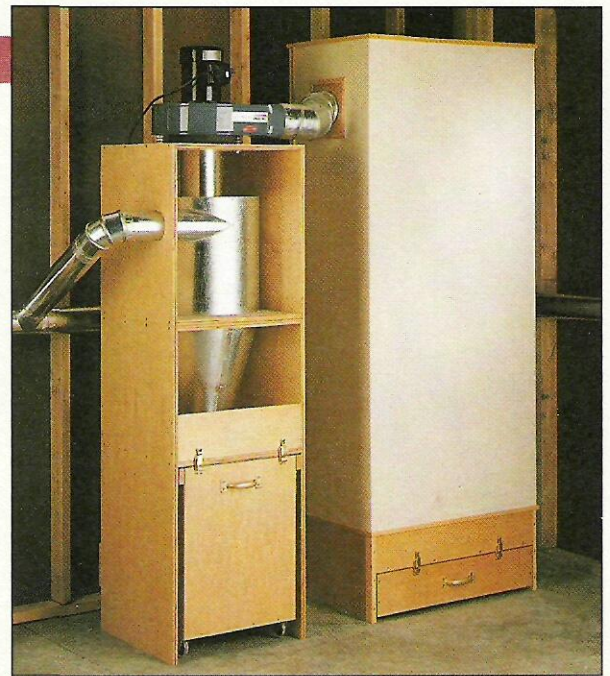

Cyclone: The whirling motion set up by the cyclone separates large chips out of the incoming air.

Chip Bin: As these chips funnel down, they drop into a bin that rolls out for easy emptying.

Filter Box: Cotton fabric stretched around a wood frame filters fine dust particles out of the air.

Dust Drawer: Fine dust particles settle out of the air into a drawer at the bottom of the filter box.

There's nothing I like better than making sawdust. What I don't like is breathing it in and sweeping it up at the end of the day. So recently I decided to get serious about a project that's been on the back burner for some time now — a shop-built dust collection system.

What I had in mind was a scaled-down version of a large commercial system. One that would sit off to one side of the shop and use a vacuum unit and a system of pipes to pick up chips and dust at individual tools. Like commercial dust collectors, this system has *two* stages.

CYCLONE. The first stage is a metal separator that removes large chips from the air by setting up a whirling motion like a cyclone, see Drawing at left.

Because the cyclone removes the chips *before* they pass through the vacuum, you don't get big chunks of material hitting the fan blades inside the vacuum. As a result, the vacuum runs quiet and the fan isn't as likely to get damaged.

FILTER BOX. The second stage of this system is a filter box that screens out the fine dust particles. Since only fine dust gets blown into the box, it doesn't fill up very quickly. So there's more filter area to do what it's intended to do — clean the air before it recirculates in the shop. (For more on building the filter box, see page 22.)

EASY TO EMPTY. The design of this system also makes it easy to empty the chips and dust. A roll-around bin collects chips under the cyclone. And there's a dust drawer to catch the fine dust particles that settle to the bottom of the filter box.

HOOK-UPS. But no dust collector is complete without a way to connect individual tools into the system. To control the flow of air at each tool and direct chips into the system, we've added several shop-made hook-ups, refer to the article on page 24.

Cyclone

The heart of the dust collection system is a cyclone that separates the large chips out of the incoming air. The cyclone is designed to work together with a vacuum that draws air into the system.

VACUUM. There are a couple of options for the vacuum. You can hook an existing portable dust collector up to the cyclone, refer to photo on page 21. Or you can buy a vacuum. (I bought a vacuum that draws 500 cubic feet of air per minute, see page 31 for sources.)

CYCLONE. Regardless of the vacuum, what causes the chips to settle out is the *shape* of the cyclone. This cyclone is built up from two shapes — a cylinder and a cone. Both shapes are formed from sheet metal. I used 20"-wide galvanized steel flashing. (For a complete hardware kit, see page 31.)

The cylinder and cone are held in place by two plywood frames that are stacked on top of each other like building blocks. The bottom frame houses the cone and a bin for the chips; the top frame supports the cylinder and the vacuum.

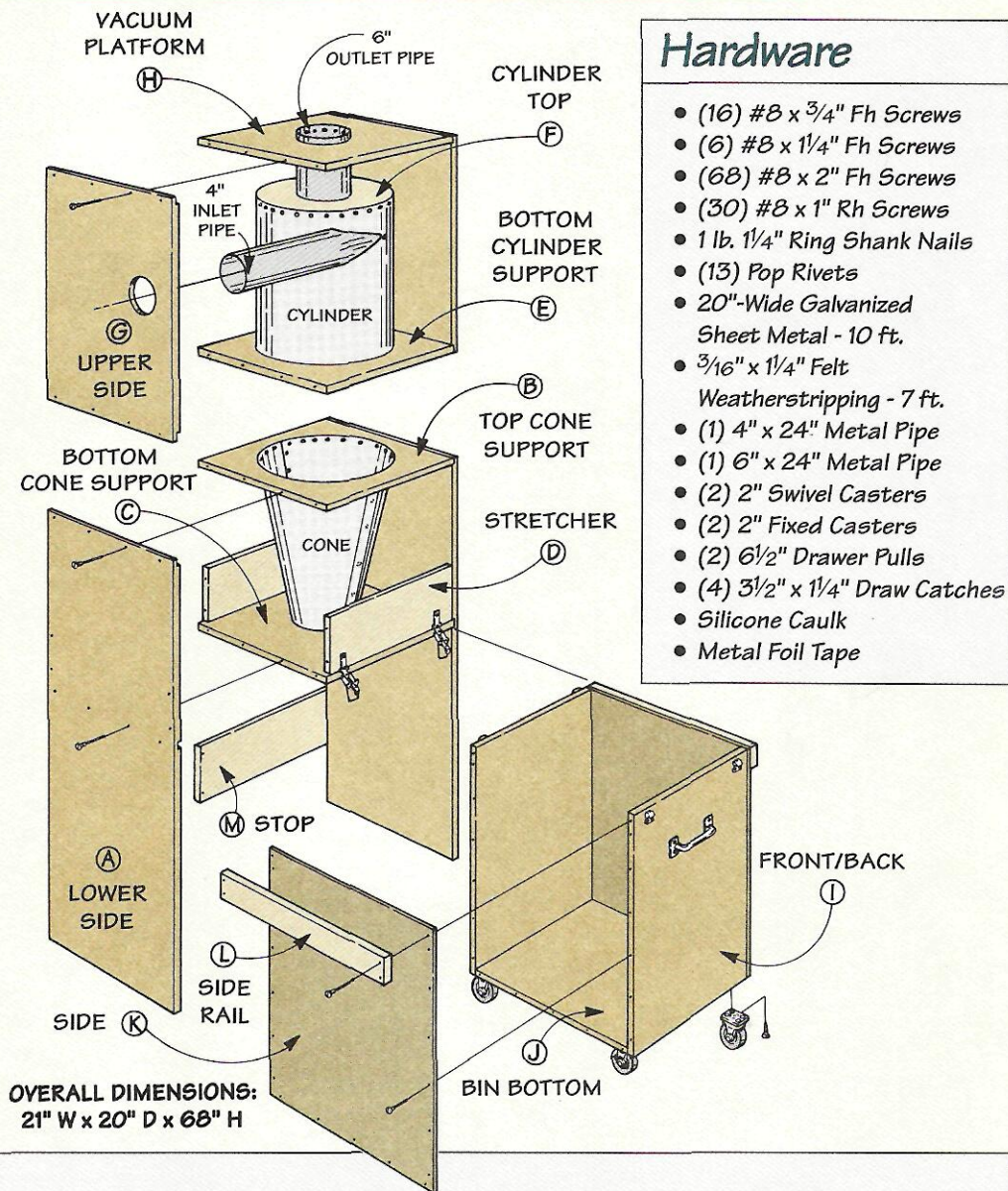

- ### Hardware
- (16) #8 x 3/4" Fh Screws
 - (6) #8 x 1/4" Fh Screws
 - (68) #8 x 2" Fh Screws
 - (30) #8 x 1" Rh Screws
 - 1 lb. 1/4" Ring Shank Nails
 - (13) Pop Rivets
 - 20"-Wide Galvanized Sheet Metal - 10 ft.
 - 3/16" x 1/4" Felt
 - Weatherstripping - 7 ft.
 - (1) 4" x 24" Metal Pipe
 - (1) 6" x 24" Metal Pipe
 - (2) 2" Swivel Casters
 - (2) 2" Fixed Casters
 - (2) 6 1/2" Drawer Pulls
 - (4) 3 1/2" x 1 1/4" Draw Catches
 - Silicone Caulk
 - Metal Foil Tape

OVERALL DIMENSIONS:
21" W x 20" D x 68" H

Materials

Cone

- A Lower Sides (2) 20 x 44 - 3/4 Ply
- B Top Cone Support (1) 20 x 20 - 3/4 Ply
- C Bottom Cone Sppt. (1) 20 x 20 - 3/4 Ply
- D Stretchers (2) 6 x 19 1/2 - 3/4 Ply

Cylinder

- E Bottom Cyl. Sppt. (1) 20 x 20 - 3/4 Ply
- F Cylinder Top (1) 16"-Dia. Disk - 3/4 Ply
- G Upper Sides (2) 20 x 24 - 3/4 Ply
- H Vacuum Platform (1) 20 x 20 - 3/4 Ply

Chip Bin

- I Front/Back Pieces (2) 17 1/2 x 22 3/8 - 3/4 Ply
- J Bin Bottom (1) 17 1/2 x 18 1/2 - 3/4 Ply
- K Sides (2) 20 x 22 3/8 - 1/8 Masonite
- L Side Rails (2) 3/4 x 2 - 20
- M Stop (1) 6 x 21 - 3/4 Ply

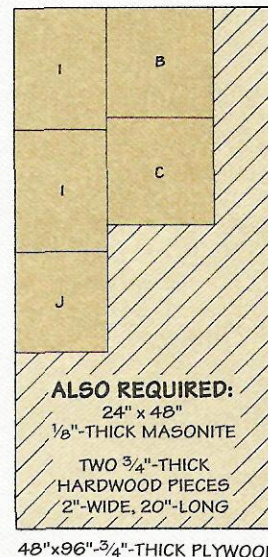
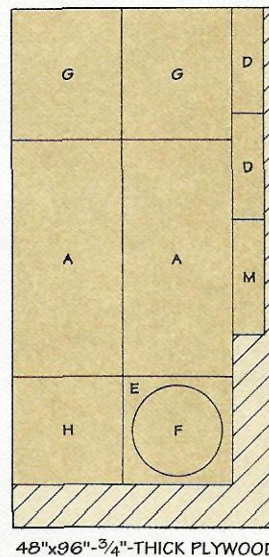

ALSO REQUIRED:

- 24" x 48"
- 1/8"-THICK MASONITE
- TWO 3/4"-THICK HARDWOOD PIECES 2"-WIDE, 20"-LONG

The Cone

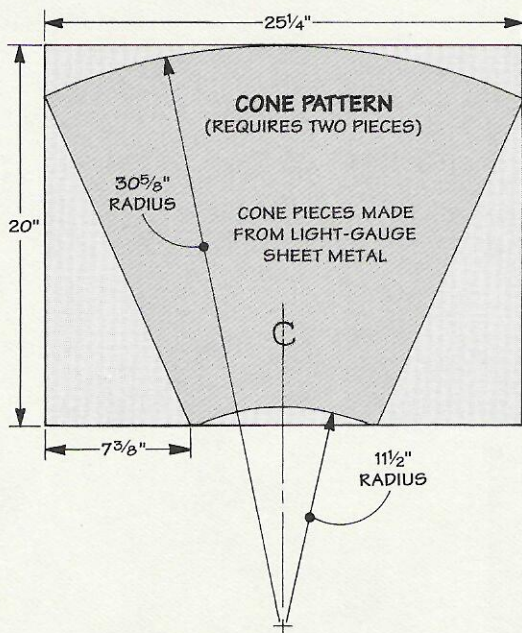

■ I started work by making a plywood frame for the lower half of the cyclone separator. To provide room for the chip bin, the *lower sides (A)* of this frame are 44" long (tall), see Fig. 1. After cutting the sides to length, I cut a

rabbet and a dado in each piece to accept two plywood support pieces, see Fig. 1a.

SUPPORTS. The supports are just square pieces of plywood with holes cut in the center to serve as a form for the cone. Because the cone is larger at the top than the bottom, the holes are different sizes.

There's a 16"-diameter hole in the *top cone support (B)*, and a 6 3/8"-diameter hole in the *bottom cone support (C)*, see Fig. 2. Because the walls of the cone taper, the edges of these holes are cut at an angle. To do this, I cut both holes with a sabre saw tilted to 15°, see Fig. 2a.

ASSEMBLY. After cutting the holes, the next step is to assemble the frame. This is just a matter of gluing and screwing the top and bottom cone supports to the sides, refer to Fig. 1.

CONE. With the frame assembled, work can begin on the cone. It's made from two wedge-

shaped pieces of sheet metal.

To lay out each piece, you can make a pattern like the one shown at left. Or there's a full-size pattern available, see page 31.

After cutting out the cone pieces with a pair of tin snips, they're fastened together along one edge. To hold these pieces together, I used pop rivets that I picked up at the local hardware store. (For more on using pop rivets, see the box on page 17.)

DRILL HOLES. With the rivets in hand, the next step is to drill holes that match the diameter of the rivets. I found it easiest to lay the pieces out flat so there's 1" overlap down the center seam, see Fig. 3a. The only problem is keeping the pieces from moving while you drill the holes.

To solve this, I aligned the top and bottom edges so they're flush, and temporarily taped the seam together, see Fig. 3. Then it's just a matter of drilling a series of holes and installing the

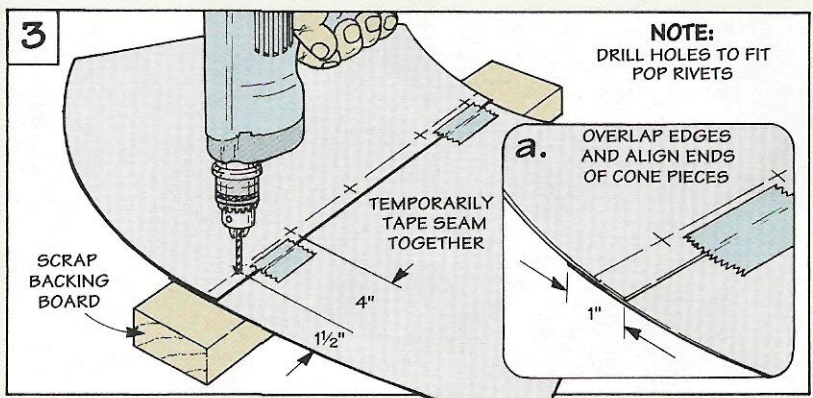
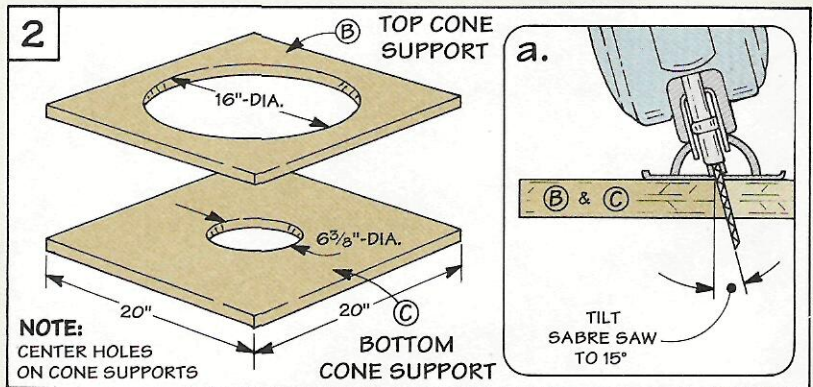
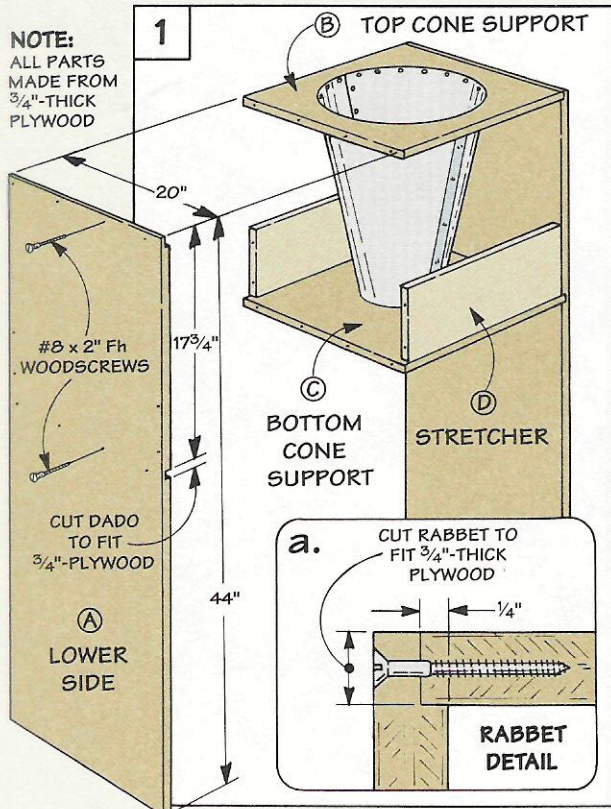

rivets. Note: I used a scrap 2x4 as a backing board when drilling the holes.

FORM CONE. Now you're ready to put the cone in place. At this point, it's no big deal if it's not a perfect cone. Just as long as it's rolled up tight enough to slip the metal down through the top and bottom cone supports.

The thing to keep in mind here is where the seam that's *not* riveted together is located. To ensure that it faces an open end of the frame (instead of the side), I centered the *riveted* seam on an open end of the cone supports, see Fig. 4.

Although this *roughly* positions the metal, you'll still need to slide it up or down a bit to get the top and bottom edges flush with the cone supports. The trick is to keep both edges aligned while you attach the metal to the supports.

ATTACH METAL. What worked best for me is to tackle a small section at a time. So I started at the riveted seam and worked both ways, nailing the top and bottom edges in place, see Fig. 4a. Note: I used hardened ring-shank nails to punch through the metal.

RIVET SEAM. After nailing the cone all the way around, the last

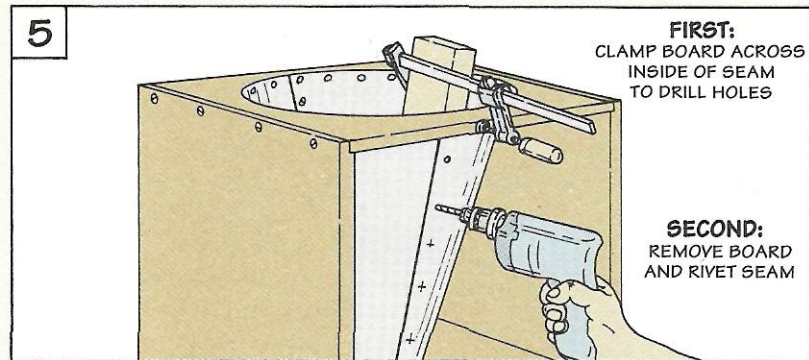
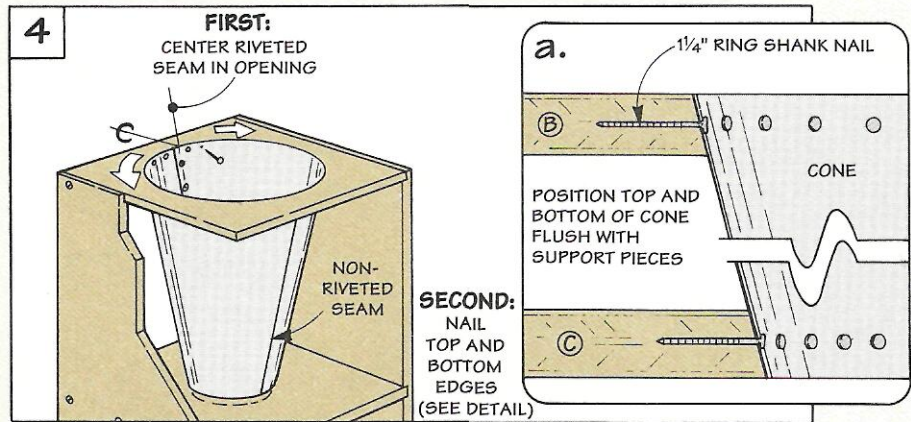

seam can be riveted. To prevent the metal from crumpling when drilling the holes for these rivets, I clamped a board over the inside of the seam, see Fig. 5.

SEAL SEAMS. All that's needed to complete the cone is to seal the seams. To do this, I covered each seam with a strip of metal foil tape. (You could also use duct

tape.) Then apply a thin bead of silicone caulk where the metal cone meets the plywood supports, see Fig. 6.

STRETCHERS. Finally, to keep the frame from racking, I added two *stretchers* (D). These are just pieces of plywood that are cut to fit between the sides and screwed in place, see Fig. 6.

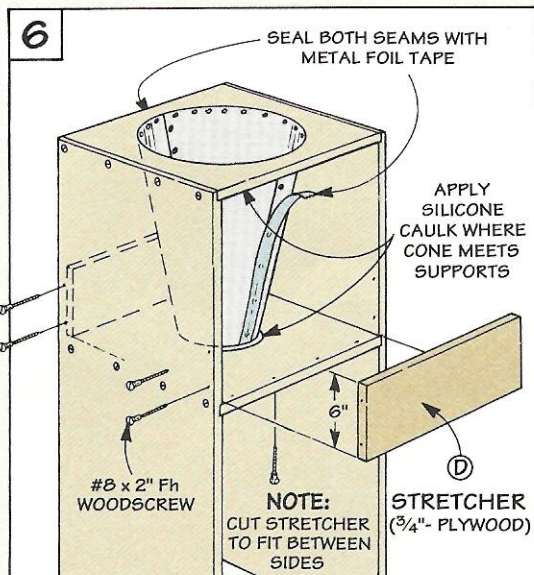

Pop Rivets

Pop rivets provide a quick and easy way to securely fasten two pieces of metal together. After drilling a hole to fit the rivet, a rivet tool or "gun" is used to compress the rivet, see photo at right.

What makes this work is a pin that passes through a hole in the rivet, see photo above. The long end of this pin is gripped tightly in the gun. The opposite end has a mushroom-shaped "ball" that's *larger* than the hole in the rivet.

When you squeeze the handles

of the gun, the pin pulls back and draws the ball against the rivet. This flares the end of the rivet. Once the rivet is permanently set, the pin breaks off or "pops."

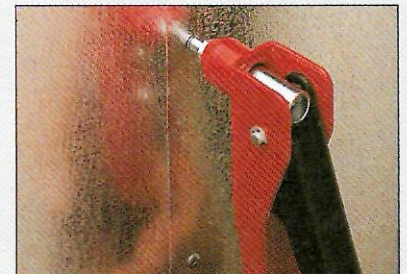

The Cylinder

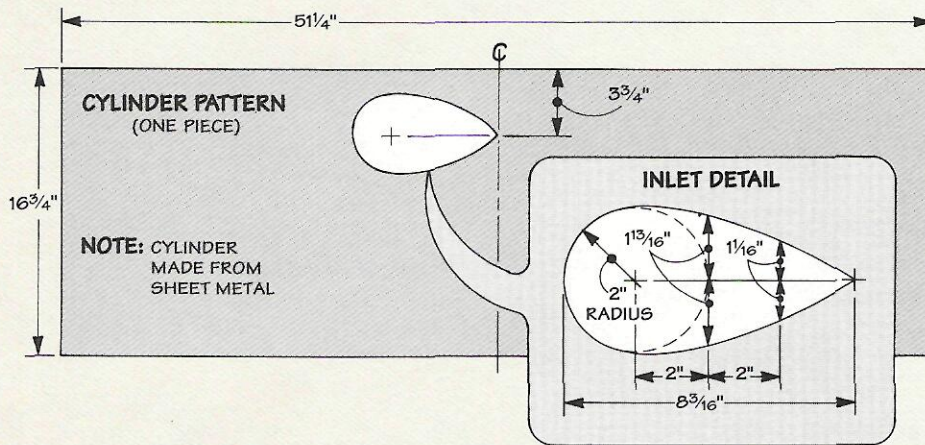

CYLINDER. Now work can begin on the cylinder. Basically, it's just a rectangular piece of sheet metal. The only unusual thing is a teardrop-shaped opening near the top, see pattern at left. (For a full-size pattern, see page 31.)

The reason for this opening is simple. Once the metal is formed into a cylinder, it allows an inlet pipe to fit tightly inside. The thing to be aware of is the *tip* of the opening is located on a line that's centered on the length of the metal. Later, this provides a reference for positioning the cylinder.

After completing the cone, the next step is to add the cylinder above it. Here again, the cylinder is made from a piece of light-gauge sheet metal that's supported by a plywood frame.

FORMS. As with the cone, I used two plywood pieces as a "form" for the cylinder. To match the opening in the top of the cone, the *bottom cylinder support* (E)

has a 16"-diameter hole cut in it, see Figs. 7 and 8. And the round disk that's removed is the perfect size for the *cylinder top* (F).

To cut out the top, I drilled a series of small holes along the circle as an entry point for the sabre saw blade, see Fig. 8a. While I was at it, I also cut a 6"-diameter opening for an outlet pipe into the vacuum, see Fig. 8.

FORM CYLINDER. After cutting the metal to shape, you can form the cylinder. Start by wrapping the metal around the top (F), nailing it in place as you work your way around, see Fig. 9.

Now the metal can be fit in the opening in the bottom support (E). This is just a matter of matching the centerline drawn

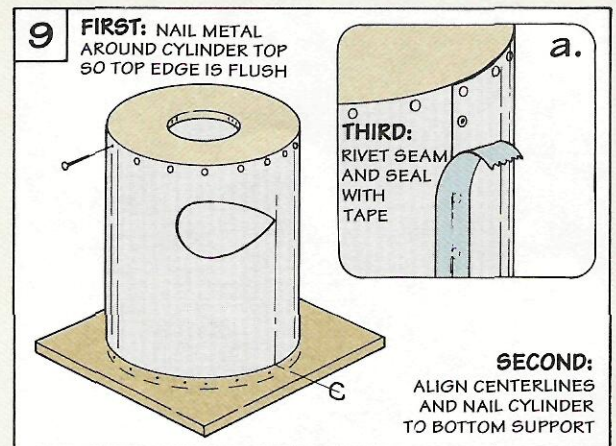
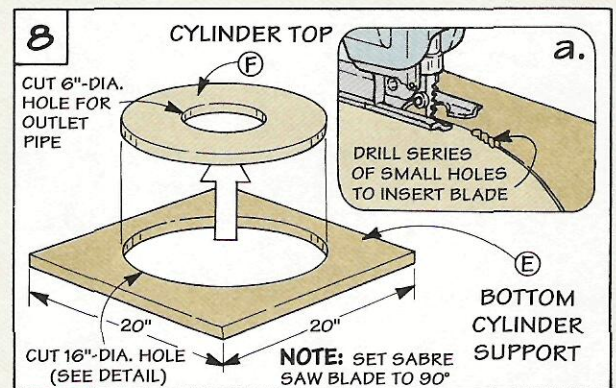
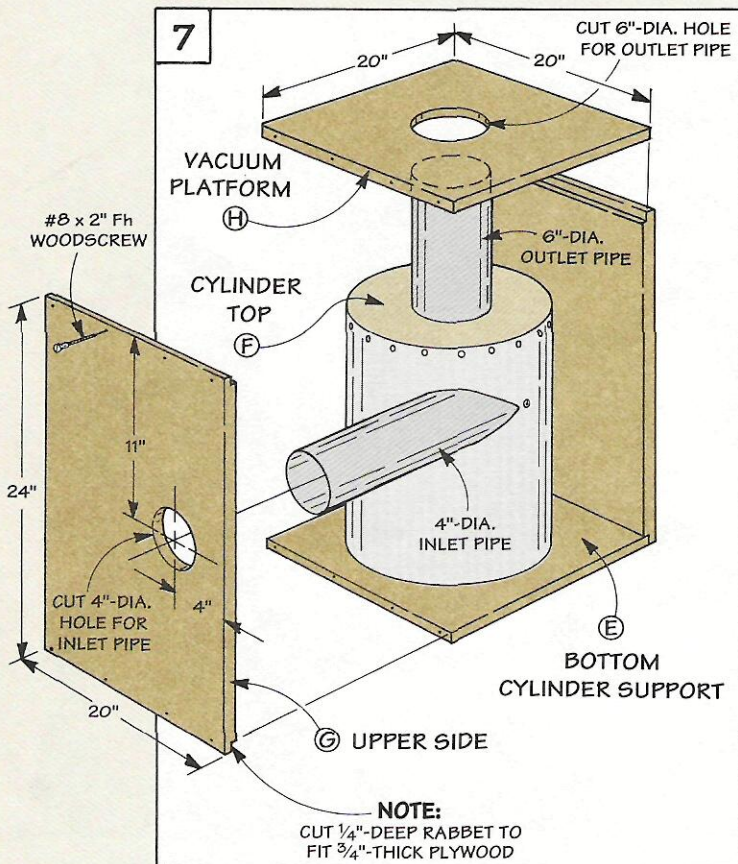

earlier with a line centered on the support, then nailing the metal in place, see Fig. 9.

RIVET SEAM. The next step is to rivet the seam. As with the cone, I used a backing board to support the metal when drilling the holes. Then, after installing the rivets, seal the seam with a strip of metal foil tape, see Fig. 9a.

TOP FRAME. At this point, the top frame can be built around the cylinder. This frame consists of two *upper sides* (G) and a *vacuum platform* (H), refer to Fig. 7. Each side is rabbeted at the top and bottom ends to accept the vacuum platform and the bottom cylinder support.

To allow the inlet pipe to pass through the frame, there's a 4"-diameter hole cut in one side piece. Also, before screwing the frame together, cut a 6"-diameter hole in the vacuum platform for an outlet pipe that's added later.

INLET. After assembling the frame, I installed the *inlet* pipe. This is a 4"-diameter metal pipe that passes through the hole in the side and into the cylinder. To reduce the amount of pipe that sticks inside, the end is trimmed to match the opening in the cylinder.

An easy way to do this is to

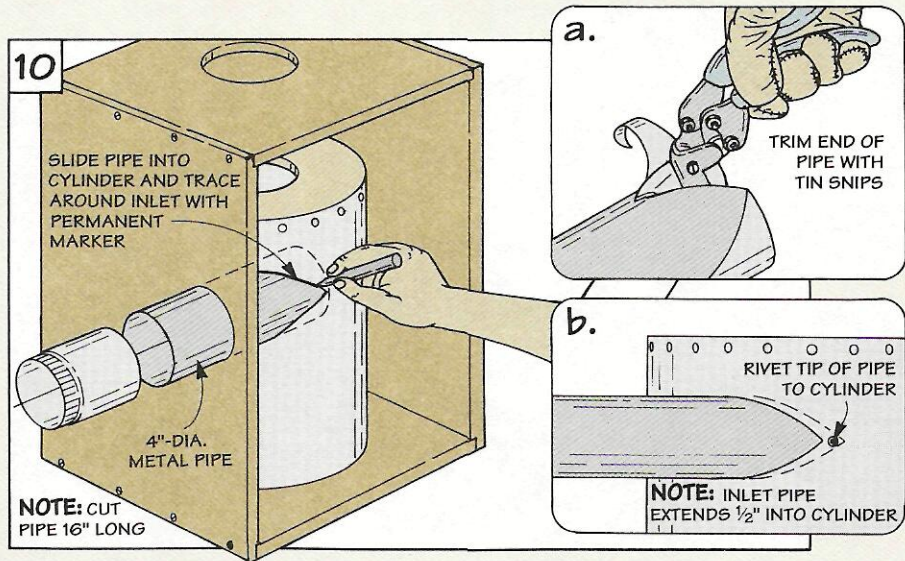

trace the shape of the opening onto the pipe with a permanent marker, see Fig. 10. Then, after trimming the pipe with a pair of tin snips, sneak the end just past the cylinder wall and rivet the tip in place, see Figs. 10a and 10b.

OUTLET. In addition to the inlet, there's a 6"-dia. *outlet* pipe that directs the fine dust into the vacuum. The idea here is to locate the bottom end of this pipe so the vacuum won't suck up large chips that are coming into the cyclone.

To do this, I slipped a 24" length of pipe through the holes in the cylinder top and the vacuum platform, see Fig. 11. The top end of

the pipe is nailed in place so it extends 1" above the vacuum platform. This way, the bottom end extends far enough into the cylinder so it carries off only the fine dust particles.

CAULK. Once the outlet is installed, the cylinder can be sealed as shown in Fig. 11a. Except for one place, I caulked around the *outside* of the metal (or pipe). But where the cylinder top meets the metal, you'll need to apply a bead of caulk on the *inside*.

STACK FRAMES. Now all that's left is to screw the top and bottom frames together so they're flush all the way around, see Fig. 12.

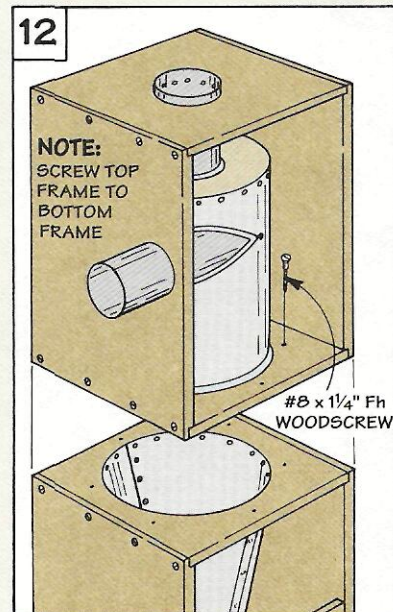
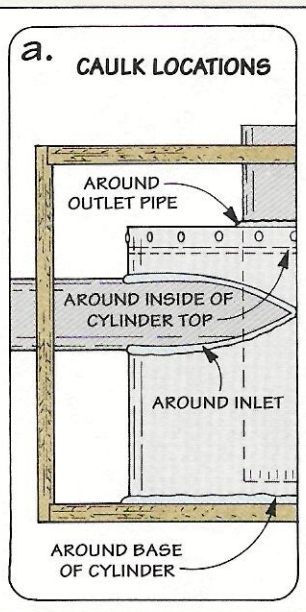
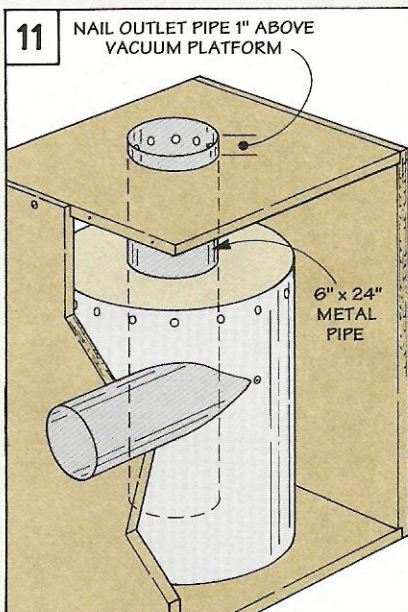

Chip Bin

One handy feature of this cyclone is a roll-around chip bin. When the bin fills up with chips, just roll it out and empty it in the trash.

There's nothing complicated about the bin. The *front/back pieces (I)* are made from $\frac{3}{4}$ "-thick plywood, and are simply glued and screwed to the *bottom (J)*, see Fig. 13. To make the bin as lightweight as possible, the *sides (K)* are made from $\frac{1}{8}$ "-thick Masonite. Here again, they're just glued and screwed in place.

SIDE RAILS. Next, to help stiffen the sides, I attached a pair of hardwood *side rails (L)* with glue and screws. These rails also act as "bumpers" when you roll the cart in and out of the cyclone.

CASTERS. After attaching the rails, I added a set of four casters. To help steer the bin, two swivel casters are screwed in place along the front edge, and a pair of fixed casters along the back.

STOP. Next, to center the bin under the cyclone, I screwed a plywood *stop (M)* to the back of the lower sides (A), see Fig. 13. This way, you just push the bin in until it hits against the stop.

But just rolling the bin under the cyclone isn't enough. The key is to seal it so chips don't blow out.

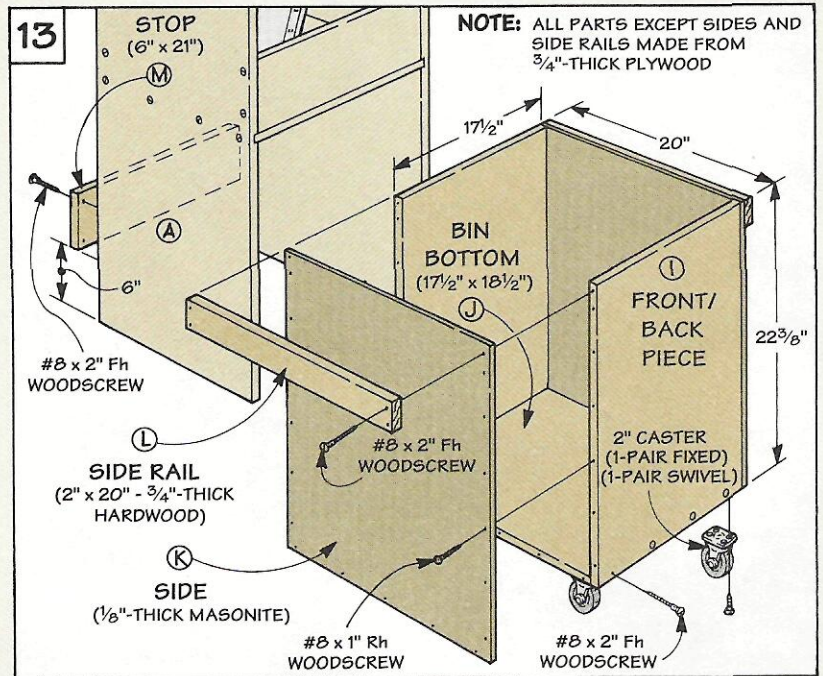

To do this, I used a two-part system.

GASKET. The first part is a "gasket" made from pieces of felt weatherstripping, see Fig. 14. After cutting strips of this felt to fit under the bottom cone support (C), they're stapled in place.

But to produce a good seal, the bin needs to draw up tight against the felt. That's where the second part of the system comes in.

DRAW CATCHES. To raise the bin off the floor, there's a pair of

draw catches on the front and back of the cyclone, see Fig. 15. When you snap the catches shut, the bin compresses the felt and creates an airtight seal. To locate the catches, I clamped the bin in the "closed" position and screwed them in place, see Figs. 15 and 15a.

DRAWER PULLS. Finally, to make it easy to lift and empty the bin, I screwed a heavy-duty drawer pull on the front and back of the bin.

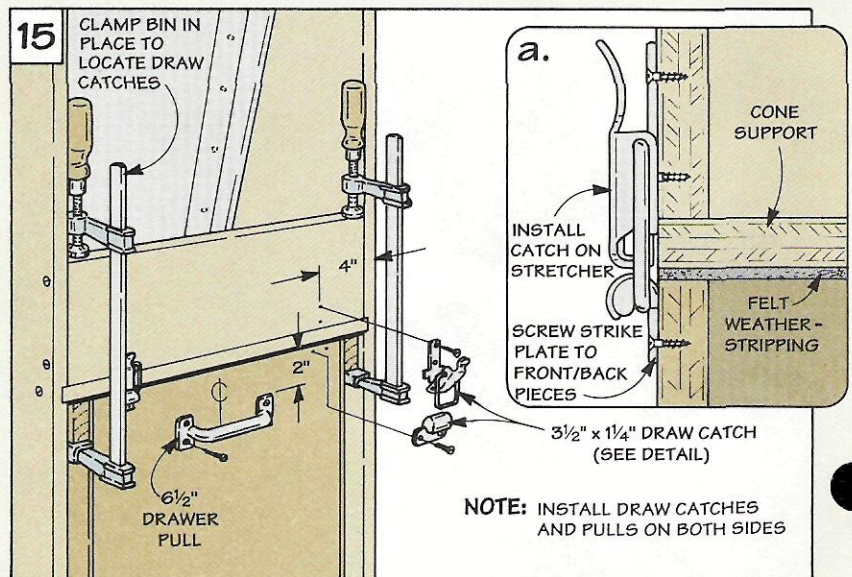
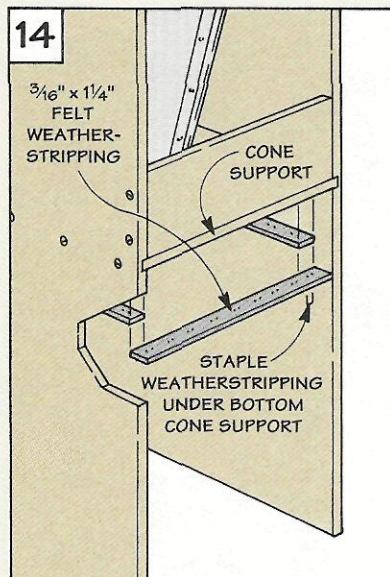

Connecting the Vacuum

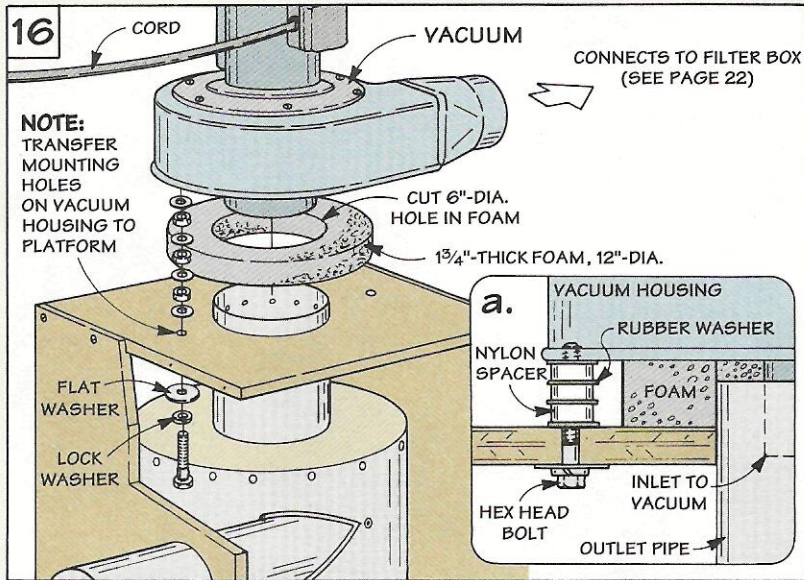

At this point, all that's left to complete the cyclone is to connect the vacuum and motor.

If you're using a portable dust collector, run a length of flexible hose from the inlet to the outlet pipe from the cyclone, see photo. Note: You'll need a reducer and a hose clamp to attach the hose.

PLATFORM MOUNT. A more compact setup is to mount the vacuum on top of the vacuum platform. Here, the inlet of the vacuum fits loosely *inside* the outlet pipe from the cyclone. To keep the vacuum from sucking in outside air, you need to make an airtight seal between the inlet and the outlet.

DOUGHNUT. What worked well for me was to cut a "doughnut" from a piece of 1 3/4"-thick soft foam (like the kind available at fabric stores). The doughnut fits around the outlet pipe. This way, when you mount the vacuum, its weight squeezes down the foam and forms a gasket around the outlet.

The trick is to compress the foam *without* having the vacuum "bottom out" on the pipe. This requires raising the vacuum off the platform. To do this, I used a stack of nylon spacers and rubber washers at each mounting point, see Fig. 16a.

Depending on your vacuum, the location of these mounting points (and the fasteners) will vary. The vacuum I used had threaded holes in the housing, so I attached it with hex bolts. But you may need to drill holes and use self-tapping screws. Either way, slipping on a

Optional Hook-Up

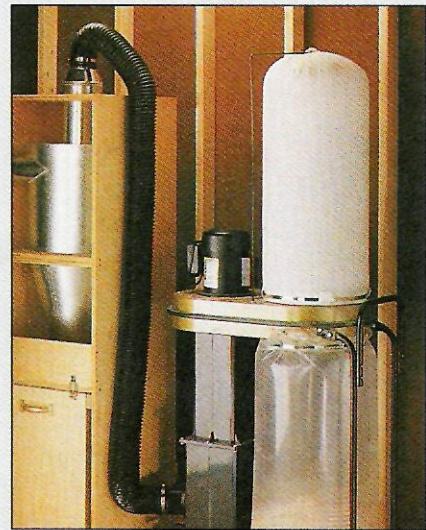

To connect a portable dust collector, run a flexible hose from the inlet of the vacuum to the cyclone.

lock washer keeps the bolts (or screws) from vibrating loose.

ELECTRICAL HOOK-UP. One final note. You can either plug the vacuum into an outlet and use the switch to turn it on and off. Or, a better solution is a remote control switch, see the box below.

Remote Control

Walking across the shop to turn the vacuum on (or off) each time you use a tool can be a nuisance. And the alternative (installing a separate switch at each tool) can involve a lot of complicated wiring.

So when I ran across an article about a remote control switch, I decided to give it a try. It was just what I wanted — an inexpensive system that didn't require a lot of wiring. (For more information, see Sources on page 31.)

Like a garage door opener, the system uses a battery-operated control that sends a radio signal, see Drawing. This signal is picked up by a transceiver which plugs into a special outlet. Note: This outlet replaces an existing outlet.

SPLIT RECEPTACLE. What makes this outlet different is that the top and bot-

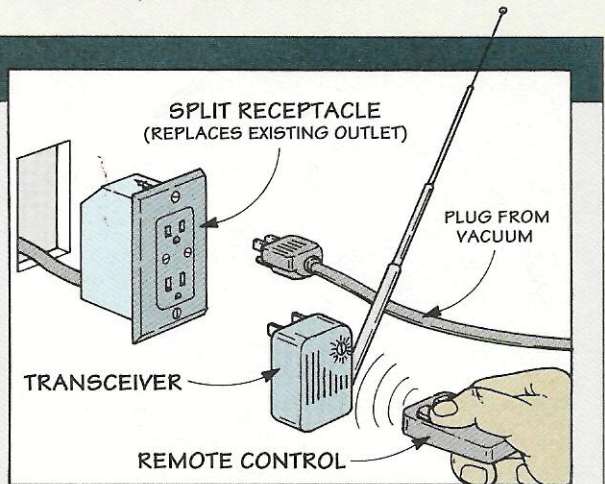

tom receptacles are "split." This means that the bottom plug-in is always "on," while the top plug-in has a built-in switch that can be turned on or off.

To control the switch, just plug the transceiver in at the bottom, and the vacuum into the top. When the transceiver gets the signal from the remote control, it sends it to the switch which turns the vacuum on or off.

Filter Box

A wood frame wrapped with fabric filters the fine dust particles out of the air.

Most dust collection systems rely on fabric bags to filter out fine dust particles. But there are a couple of problems with these. First, they're expensive. And second, I've found that most bags are too small for the system. When it's turned on, the filter bag quickly inflates, producing a cloud of fine dust that settles over the entire shop.

To solve both these problems, I didn't use a bag. Instead, I built a large filter box, see photo. It's just a wood frame wrapped with inexpensive fabric. Since the fabric is stretched around the frame, it can't

collapse. So when the system is turned on — no more dust cloud.

FILTER MATERIAL. In designing the filter box, the first thing I had to figure out was what to use for fabric. I found just what I needed at a local fabric store — 10 oz. cotton duck.

SIZE. The only other thing to decide was how big to make the frame. The height was easy. I sized the frame to fit the width of the fabric (72"). All that was left was to figure out how much filter area I needed.

If the filter area is too small, the dust gets forced right

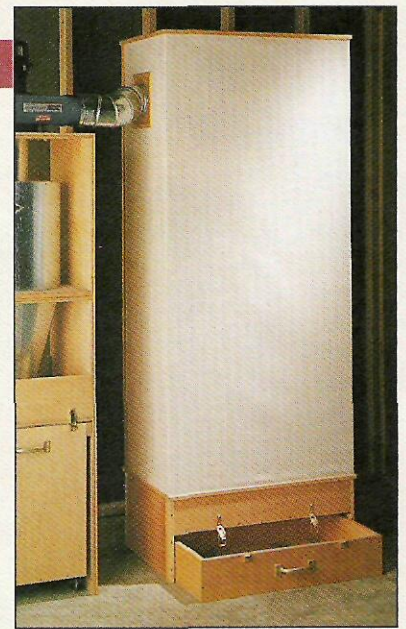

through the fabric like a clogged bag on a vacuum cleaner. So after taking into account the size of my vacuum (500 CFM), I came up with the design shown in Fig. 1.

Materials

Frame

A Uprights (4)	$\frac{3}{4}$ x $\frac{1}{2}$ - 83 $\frac{1}{4}$
B Bottom Plates (2)	12 $\frac{3}{4}$ x 17 - $\frac{3}{4}$ Ply
C Rails (6)	$\frac{3}{4}$ x $\frac{1}{2}$ - 17
D Inlet Plate (1)	19 $\frac{1}{8}$ x 17 - $\frac{3}{4}$ Ply
E Stretchers (10)	$\frac{3}{4}$ x $\frac{1}{2}$ - 30 $\frac{1}{2}$
F Top (1)	20 x 32 - $\frac{3}{4}$ Ply
G Support Pieces (2)	5 $\frac{3}{4}$ x 30 $\frac{1}{2}$ - $\frac{3}{4}$ Ply
H Side Pieces (2)	$\frac{3}{4}$ x $\frac{1}{2}$ - 30 $\frac{1}{2}$
I End Pieces (2)	$\frac{3}{4}$ x $\frac{1}{2}$ - 15 $\frac{1}{2}$

Dust Drawer

J Front/Back Pieces (2)	6 x 30 - $\frac{3}{4}$ Ply
K Drawer Sides (2)	6 x 19 - $\frac{3}{4}$ Ply
L Drawer Bottom (1)	19 x 29 - $\frac{1}{8}$ Masonite

Also needed: 26 feet of $\frac{1}{4}$ x $\frac{3}{4}$ screen molding

Hardware

- (66) #8 x 2" Fh Woodscrews
- (30) #8 x 3" Fh Woodscrews
- (4) $3\frac{1}{2}$ " x $\frac{1}{4}$ " Draw Catches w/Screws
- $\frac{3}{16}$ " x $\frac{1}{4}$ " Felt Weatherstripping - 9 feet
- (1) 6 $\frac{1}{2}$ " Drawer Pull w/Screws
- 3 yds. 10 oz. Cotton Duck Fabric - 72" wide
- #18 x 1" Wire Brads - 2 oz. package
- 5"-Dia. Metal Duct for Inlet

Also needed: $\frac{3}{8}$ " Staples

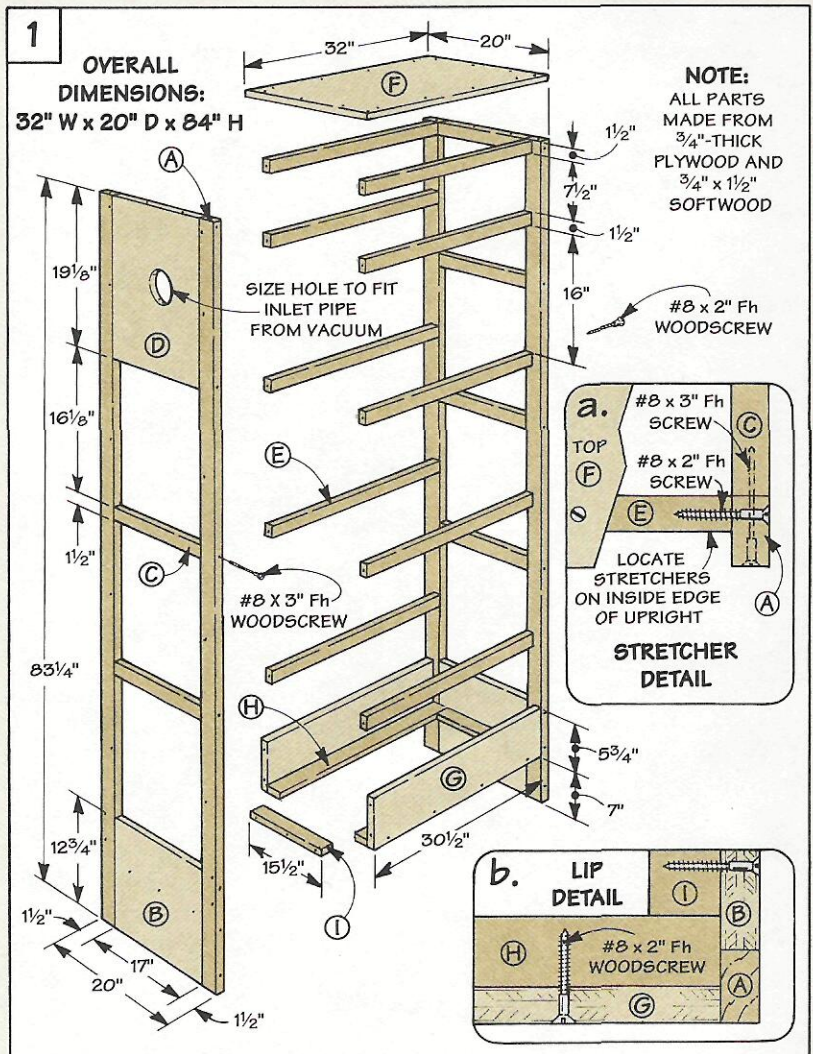

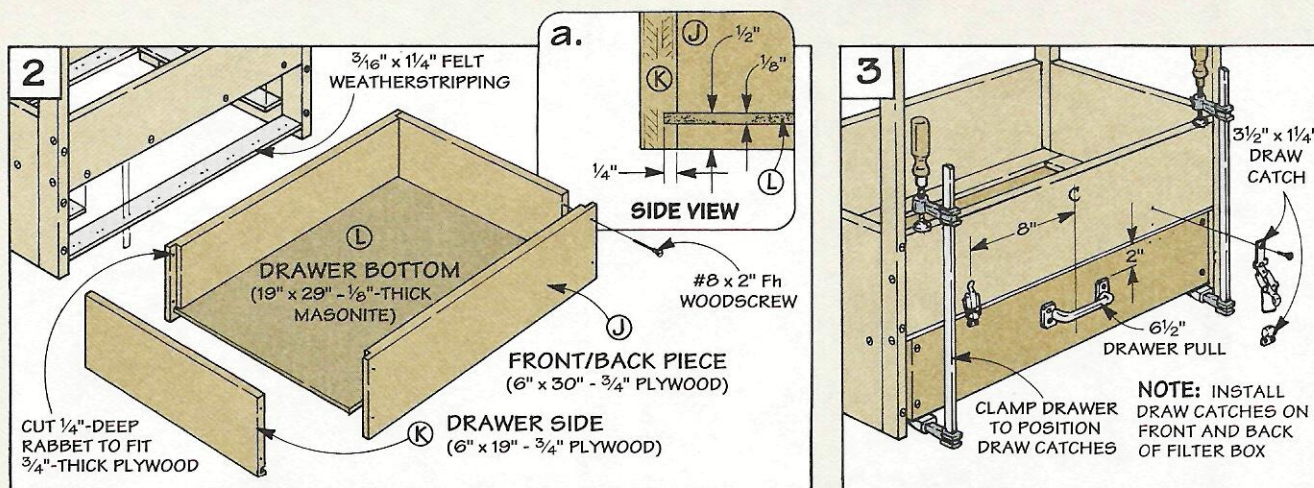

LADDERS. I started work on the frame by building two ladder-shaped end units, see Fig. 1. Each end unit consists of two *uprights* (A), a *bottom plate* (B), and several *rails* (C) screwed in between.

But these two end units aren't identical. To provide support for the pipe that comes into the box from the vacuum, there's an *inlet plate* (D) made from plywood, see Fig. 1. After cutting a hole in this plate to fit the diameter of the pipe (5") coming from the vacuum, the plate is screwed in place.

STRETCHERS. The next step is to connect the end units with *stretchers* (E), see Fig. 1. They're attached to the inside edge of the uprights with screws, see Fig. 1a.

To add rigidity to the frame, I screwed on a plywood *top* (F), see Fig. 1a. Also, two *support pieces* (G) are screwed between the uprights at the bottom to help stiffen the end of the frame.

LIP. All that's left to complete the basic frame is to add a lip around the bottom. Later, weatherstripping is attached to the lip to seal the dust drawer. This lip consists of two *side pieces* (H) screwed to the supports (G) and two *end pieces* (I) attached to the bottom plate, see Fig. 1b.

DUST DRAWER. After completing the basic frame, I made a simple drawer to catch the dust. The ends of the *front/back pieces* (J) are rabbeted to accept a pair of

sides (K), see Fig. 2. Before screwing the drawer together, a groove is cut in each piece for a 1/8"-thick Masonite *bottom* (L), see Fig 2a.

WEATHERSTRIPPING. Next, to prevent sawdust from leaking out of the drawer, I added a seal made from strips of felt weatherstripping. These strips are stapled under the lip installed earlier, see Fig. 2.

DRAW CATCHES. As with the chip bin, the drawer needs to be pulled up tight against the felt for it to seal. To do this, I installed a pair of draw catches on the front and back of the box, see Fig. 3. Here again, clamping the drawer in the "closed" position helps locate the catches so they snap tightly shut.

STRETCH FABRIC. Now you're ready to stretch the fabric around the box. The easiest way to do this is to align the edge of the fabric flush at the top, and staple one end to an upright, see Fig. 4.

Then, keeping the fabric taut, staple the top and bottom edges (not the uprights) as you work your way around. When you return to the starting point, staple the remaining end of the fabric to the same upright.

MOLDING. To keep the staples from working loose, I attached strips of screen molding over the stapled edges and the upright. Finally, after tacking strips of molding around the inlet hole, cut out the small square of fabric inside the frame, see Fig. 4a.

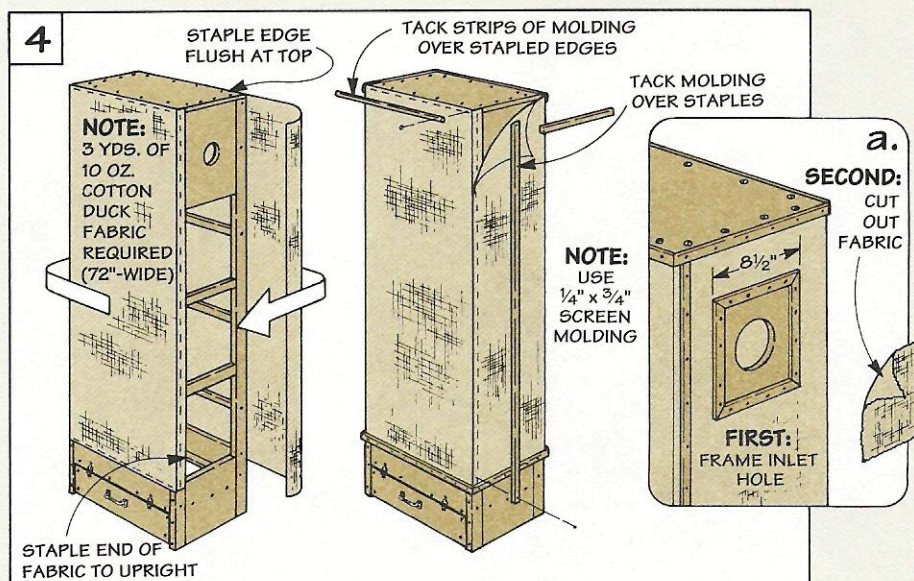

Dust Collection Pipe & Hook-Ups

Metal pipes and shop-made hook-ups direct chips through your dust collection system.

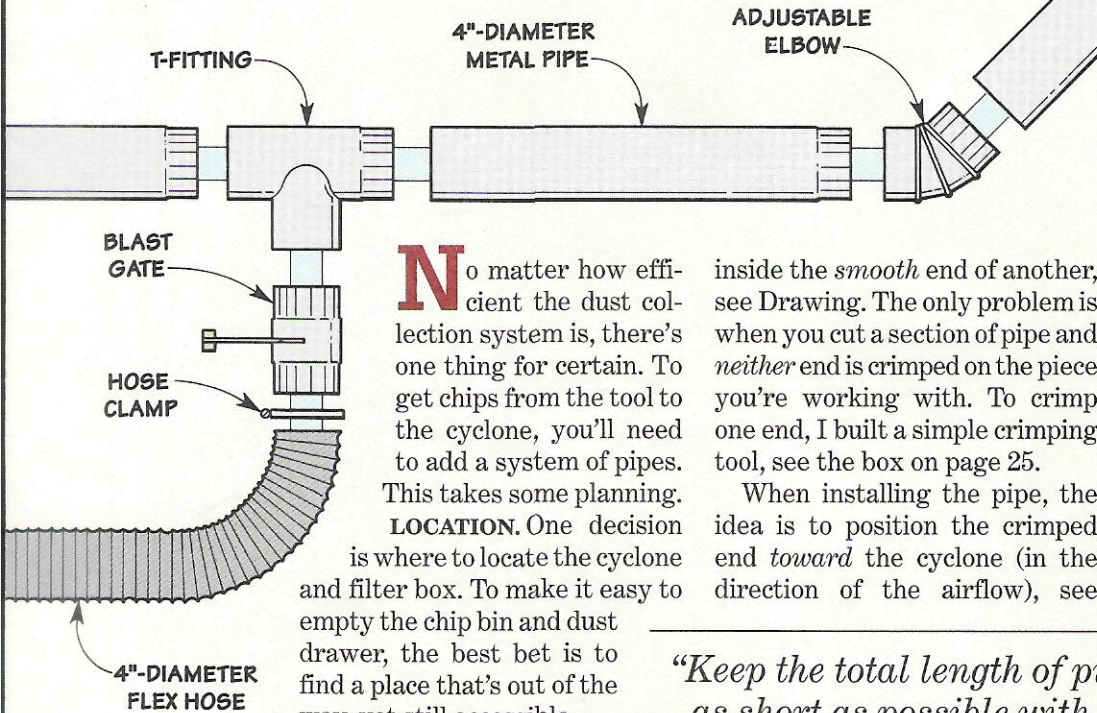
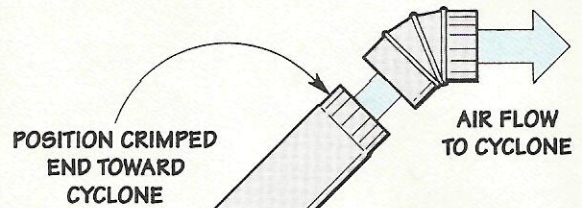

No matter how efficient the dust collection system is, there's one thing for certain. To get chips from the tool to the cyclone, you'll need to add a system of pipes. This takes some planning.

LOCATION. One decision is where to locate the cyclone and filter box. To make it easy to empty the chip bin and dust drawer, the best bet is to find a place that's out of the way, yet still accessible.

Still, you don't want to get carried away and put them in the farthest corner of the shop. That's because the longer the run, the more pressure is lost along the way, and the less suction you get at each tool.

To maintain pressure, a good rule of thumb is to keep the total length of pipe as short as possible with a minimum number of turns. Note: I used 4"-diameter metal pipe from the local hardware store.

CRIMPED END. Each section of pipe has one *crimped* end that fits

inside the *smooth* end of another, see Drawing. The only problem is when you cut a section of pipe and *neither* end is crimped on the piece you're working with. To crimp one end, I built a simple crimping tool, see the box on page 25.

When installing the pipe, the idea is to position the crimped end *toward* the cyclone (in the direction of the airflow), see

"Keep the total length of pipe as short as possible with a minimum number of turns."

Drawing. This way, chips don't catch on the end, and the air flows smoothly through the pipe.

FITTINGS. In addition to the pipe, you'll need a couple of different fittings to change the direction of the airflow. I used a 90° "T" to branch off toward individual tools, and an adjustable elbow to create a gradual turn in the pipe.

SEAL SEAMS. To ensure that the system is airtight, I ran a strip

of metal foil tape around each seam. Also, applying a bead of silicone caulk around each T-fitting keeps them from leaking.

FLEX HOSE. Another thing to consider is how to connect individual tools into the system. What I've found works best is 4"-dia. rubber-coated "flex" hose.

Because it's flexible, it makes it easy to run a line between the pipe and the tool. And once it's in place, you can move the tool without having to cut new pipe or install different fittings. (Flex hose is available through several different woodworking catalogs, see page 31 for sources.)

HOOK-UPS

But there's more to getting the system working than just pipe. You still need a way to hook up individual tools to the system.

Although there are a number of manufactured hook-ups available, their cost can add up quickly (especially if you're connecting three or four tools). So I decided to make my own.

Basically, I needed two types of hook-ups: blast gates and dust hoods. The blast gates shut the flow of air on and off at each tool. This prevents the vacuum from pulling air from more than one tool. And the dust hoods direct chips and dust into the system.

Blast Gates

To control the flow of air in the system so there's only one tool on line at a time, I added a blast gate at each tool, see photo at right. This way, I can turn the suction on (or off) at a tool simply by opening (or closing) the blast gate.

Basically, the blast gate is just a short section of 4"-dia. pipe with a slot cut in it so you can slide a piece of sheet metal in and out, see Drawing at right.

DISKS. To support the walls of the pipe when cutting the slot, I cut two plywood disks to fit inside, see Fig. 1. Then just tighten the pipe in a vise and cut the slot halfway through.

GATE. After removing the disks, the gate can be cut to fit in the slot. It's just a strip of sheet metal that's cut to the same width as the diameter of the pipe, see Drawing.

To keep air from leaking when the gate is closed, the end needs to fit tight against the curved wall of the pipe. To do this, scribe the shape of the pipe on the metal and trim the end to fit, see Fig. 2.

HANDLE. Next, I sandwiched the gate between two blocks of hardwood and tacked them to-

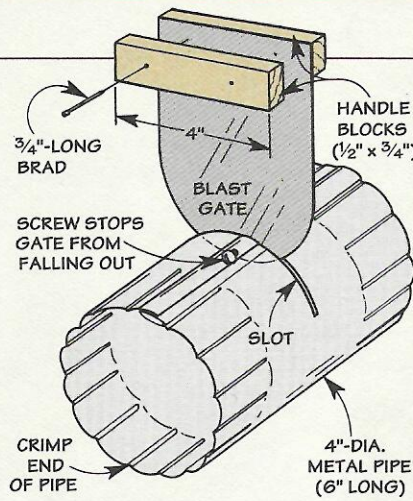

Sliding a shop-made blast gate in and out of a pipe turns the suction off (or on) at each tool.

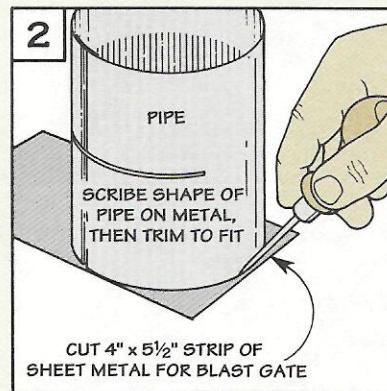
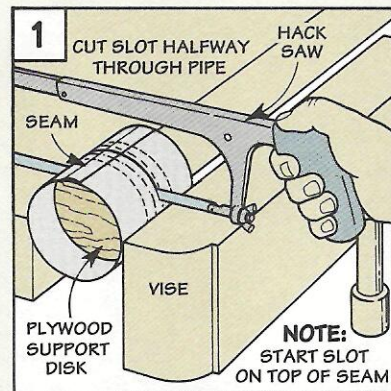

gether to serve as a handle, see Drawing above. Also, to keep the gate from falling out when it's opened, I drilled a hole and installed a screw near the curved

end of the gate.

CRIMP ENDS. Finally, I crimped both ends of the pipe and installed the blast gate between the metal pipe and the flex hose.

Crimping Tool

This shop-made crimping tool is just the ticket for crimping the end of a pipe, see photo.

It consists of three strips of 1/8"-thick steel with an angled notch cut in one end, see Detail a. The notches in the two side pieces face the opposite direction of the notch in the center piece, see Drawing.

To form a crimp in the metal, these notches need to be beveled. I filed a bevel on both sides of the center piece, and the inside edge on each of the side pieces, see Detail b.

Then drill holes, and using washers as spacers, assemble the crimping tool with bolts and lock nuts.

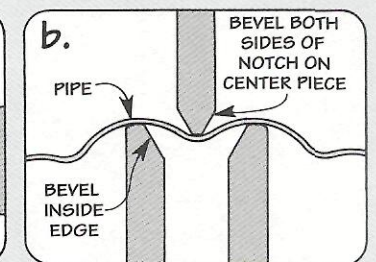
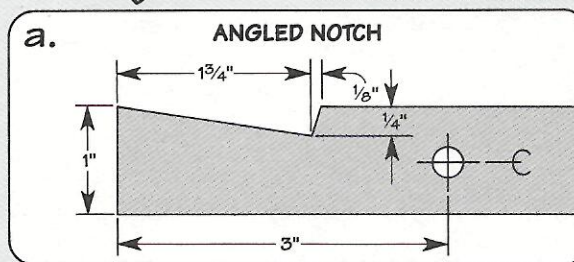
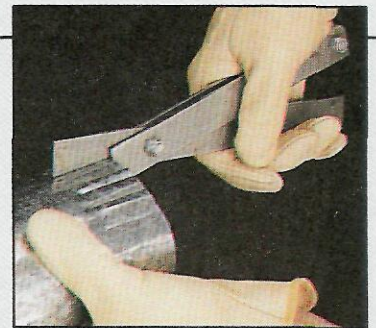
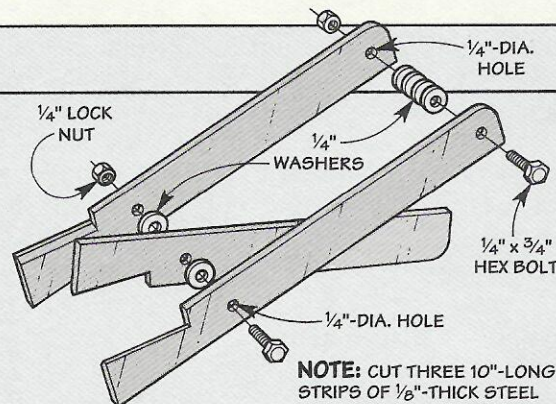

Radial Arm Saw Dust Hood

To catch the dust that scatters behind the blade of my radial arm saw, I screwed a scoop-shaped dust hood to the metal stand.

The base of this hood has a hole cut in it for a short "stub" of 4"-diameter pipe, see Drawing. Fitting a 4"-diameter flex hose over this stub connects the hood to the

dust collection system.

After nailing the stub into the base, a piece of light-gauge sheet metal is cut and bent to fit around the plywood, see pattern. Then the hood is nailed onto the base.

Note: To create a crisp corner at each of the fold lines, see the margin tip at left.

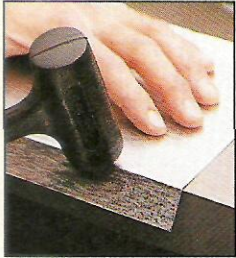
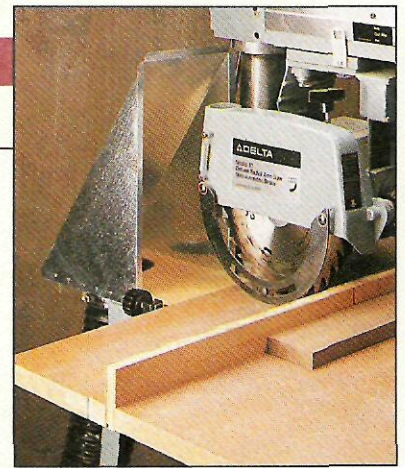

To create a sharp corner, bend the metal over the edge of your saw table with a mallet.

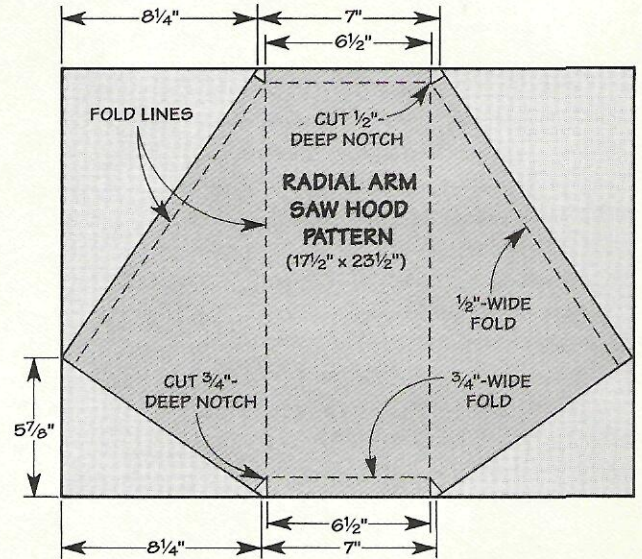
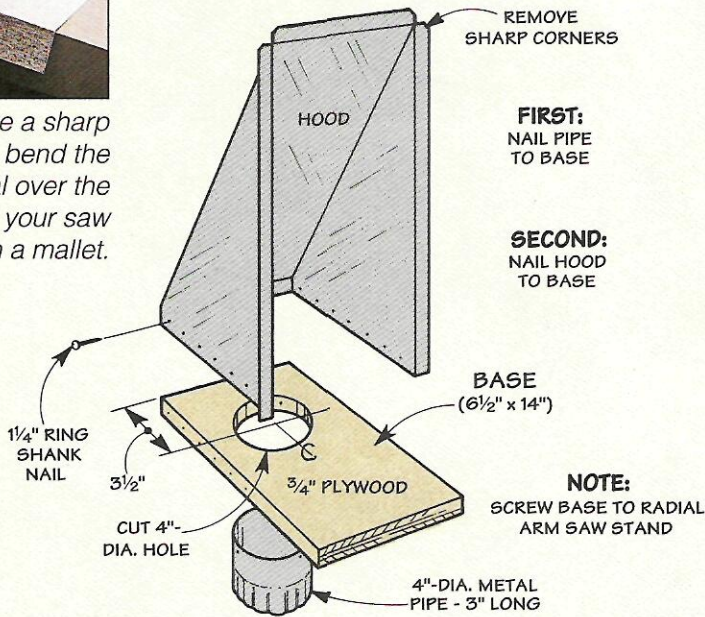

Table Saw Dust Hood

The dust created by the table saw presents a different problem. That's because the rotation of the blade carries it *below* the saw table.

To direct this dust into the system, I added a dust hood that sits in the opening below the blade. Here again, a piece of sheet metal fits around a piece of plywood and

deflects dust into the pipe, see pattern and Drawing below.

But in this case, the dust hood is attached by screwing the metal flanges to the base of the saw. Note: Depending on your saw, you may need to fit the hood into an opening cut in a plywood plate, and screw the plate to the saw base.

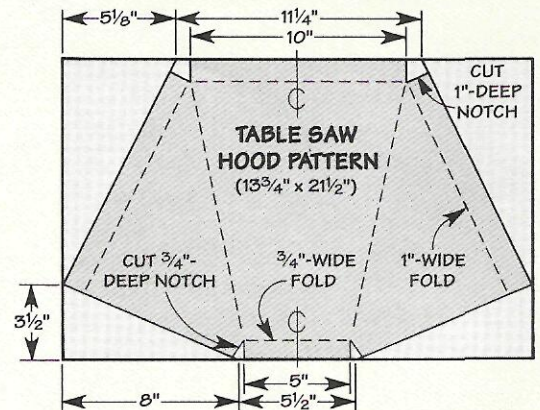
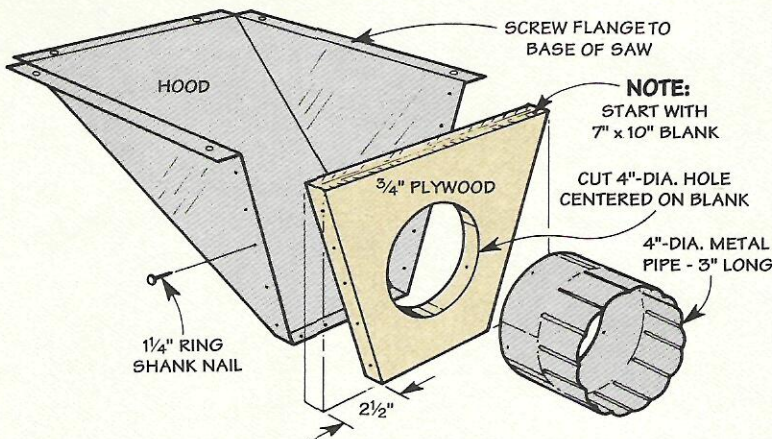

Router Table Collection Box

When using a router table, chips get thrown above *and* below the table. To pull chips into the system at both places, I built a simple collection box, see photo.

Note: Although it's designed to be screwed under the open-base router table featured in *ShopNotes* No. 1, this box can be easily adapted to other router tables as well.

Either way, the chips that get kicked out *below* the table are drawn into a narrow opening in the top of the box, refer to Fig. 2.

To collect chips *above* the table, I screwed a fence attachment to the back of the fence. It's made by

gluing a Masonite plate with a hole cut in it to two triangular pieces of hardwood, see Fig. 1.

To hook up the collection box, run a 2"-dia. hose between the fence attachment and the box. (I used the hose from my shop vacuum.) Then fit a 4"-dia. hose over the pipe stub nailed into the box.

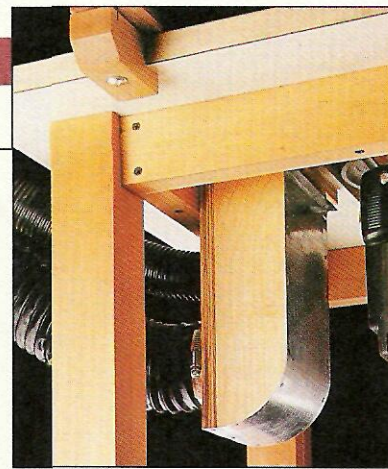

NOTE:
SCREW TO
BOTTOM OF
ROUTER TABLE

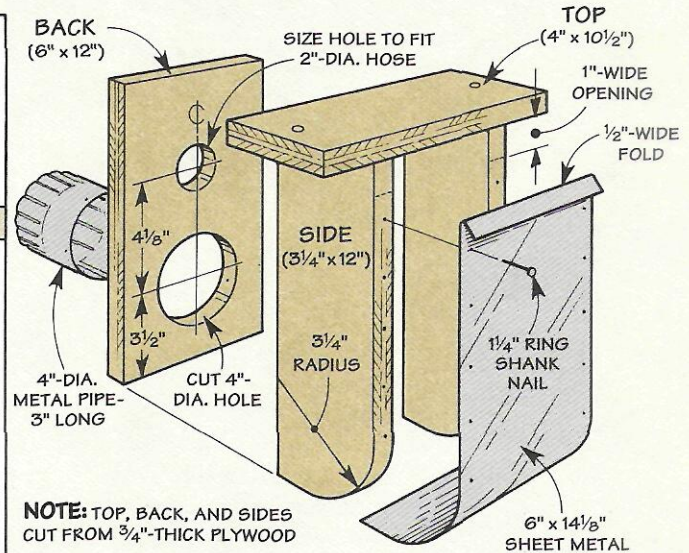
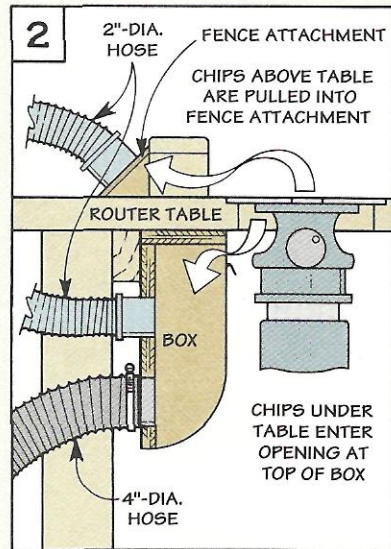
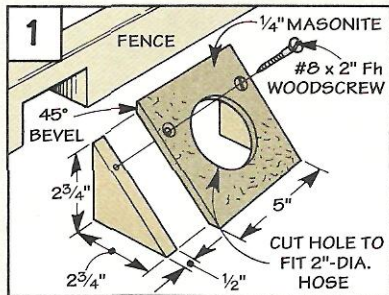

NOTE: TOP, BACK, AND SIDES
CUT FROM 3/4"-THICK PLYWOOD

Bench Pick-Up

A hand-held power sander is one of the worst culprits when it comes to filling the air in the shop with fine dust. To capture this dust, I made a pick-up that clamps to the end of my bench, see photo.

Basically, this pick-up works like a funnel. As you sand across a board, dust is drawn into the wide "mouth" at the front of the pick-up. Then it's directed into the outlet by two converging sides, see Drawing.

Like the other hook-ups, this bench pick-up is made by bending a piece of light-gauge sheet metal so it fits around pieces of plywood, see the pattern at right. And as before, a 4"-dia. pipe stub is nailed into the base which lets you connect it to the

dust collection system.

But in spite of these similarities, there are a couple of twists. First, to provide room to attach the clamps, there's an "ear" on each side of the base. Second, the ends of each of the side pieces are mitered so they're flush with the base, see Drawing.

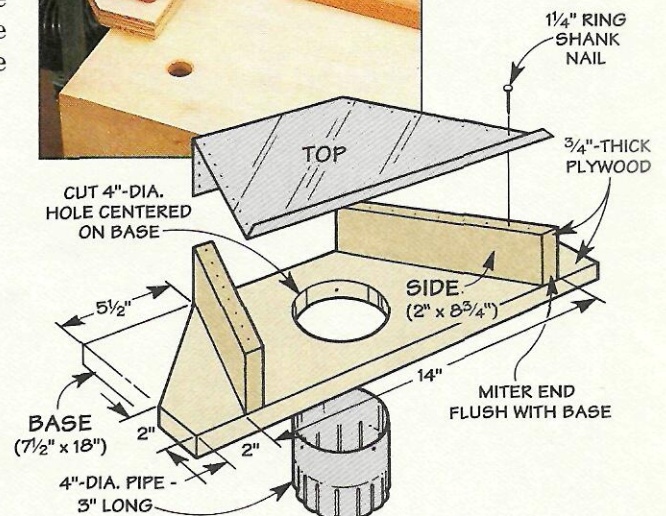
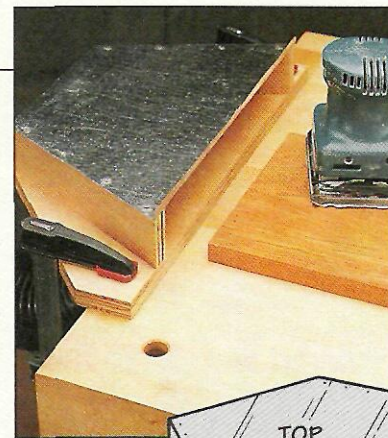
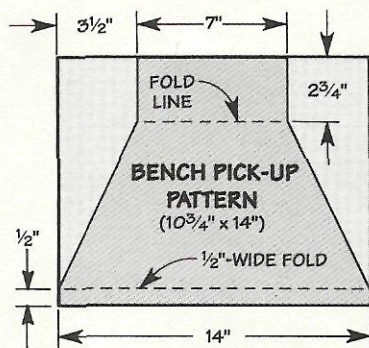

Shop Solutions

Toggle Clamp Stop Block

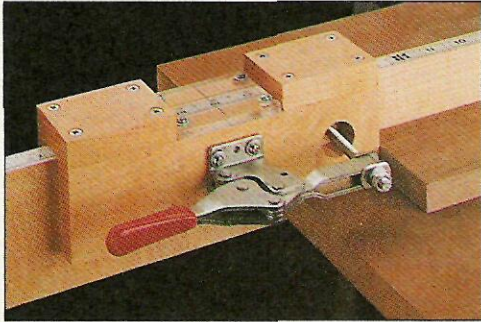

■ Accurately making repetitive cuts on a radial arm saw can be time consuming. To speed up the process, I made a sliding stop block for the fence on my radial arm saw. The stop block allows me to set up for an exact measurement quickly and accurately.

The heart of the stop block is a hold-down toggle clamp, see Drawing. The clamp is screwed to a U-shape block that fits over the fence like a saddle on a horse.

A hole in the front piece allows the spindle on the clamp to pinch against the fence. This allows the stop to lock tightly in place.

To be able to quickly and accurately position the stop, I added a self-adhesive tape measure to the top of the fence. Then I screwed

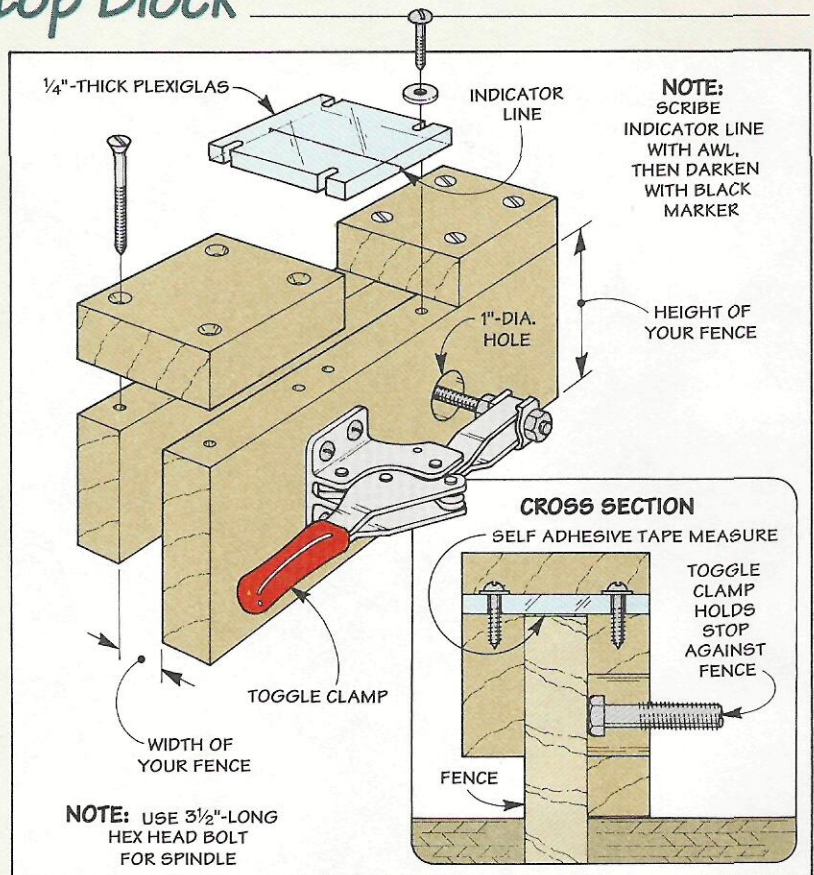

a Plexiglas indicator to the top of the stop, see Drawing.

For my stop block, I used a De-Sta-Co toggle clamp, model 227-U. And a Starret self-adhe-

sive tape measure. Both are available through most woodworking mail-order catalogs.

*Charles Gray
Lyons, Colorado*

Shop-Made Utility Knife

■ Rather than throw away used hack saw blades, I recycle them into utility knives. To make a utility knife, I just sandwich a 6" length of hack saw blade between two scrap pieces of hardwood, see Drawing. Then I wrap tape around the parts to keep them together.

After a good sharpening on my bench grinder, the hack saw blade is just about as sharp as a razor.

*David W. Hiester
Highland Falls, New York*

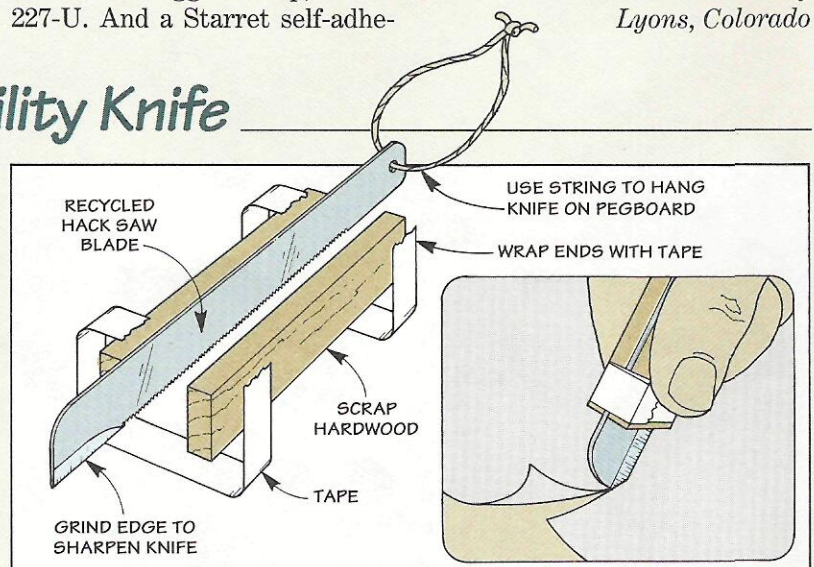

Quick Tips

■ It seems I'm always forgetting the dimensions of a workpiece before I can set up the machine. To avoid this, I write the dimensions on a chalkboard hanging behind my workbench. This way, I don't have to walk back to the workbench to recheck the plans. (A dry-erase board will also work.)

Robert DiTucci
Wayne, New Jersey

■ When finishing a project, I like to rub out each coat with an abrasive pad. But getting even pressure on the pad can be difficult. To solve this, I use the push block that came with my jointer, see photo. The foam bottom on the push block keeps the pad in place. And the handle makes it easy to control.

Herb Arndt
Ocala, Florida

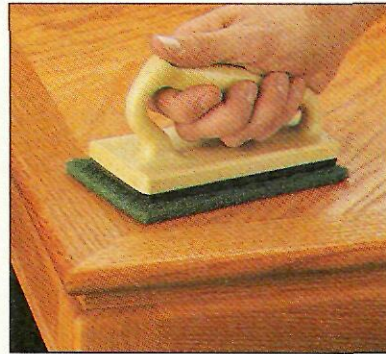

Sawhorse with Insert

■ The top of a sawhorse is always the first thing to wear out. To avoid early retirement for my horses, I made them with a replaceable insert.

To keep cost down, I used construction grade lumber and scrap plywood for all the parts.

When building my horses, I started by bevel ripping a 2x4 down the middle for the stretchers, see Drawing. Then I cut a 2x4 to length for the insert.

Next, a stretcher support (cut from a length of 2x4), is cut to fit across the bottom edge of both stretchers and the insert, see Cross Section. The ends of this support are beveled to match the angle of the stretchers.

Finally, add the legs, the upper supports, and the lower supports.

Richard Koch
Arvada, Colorado

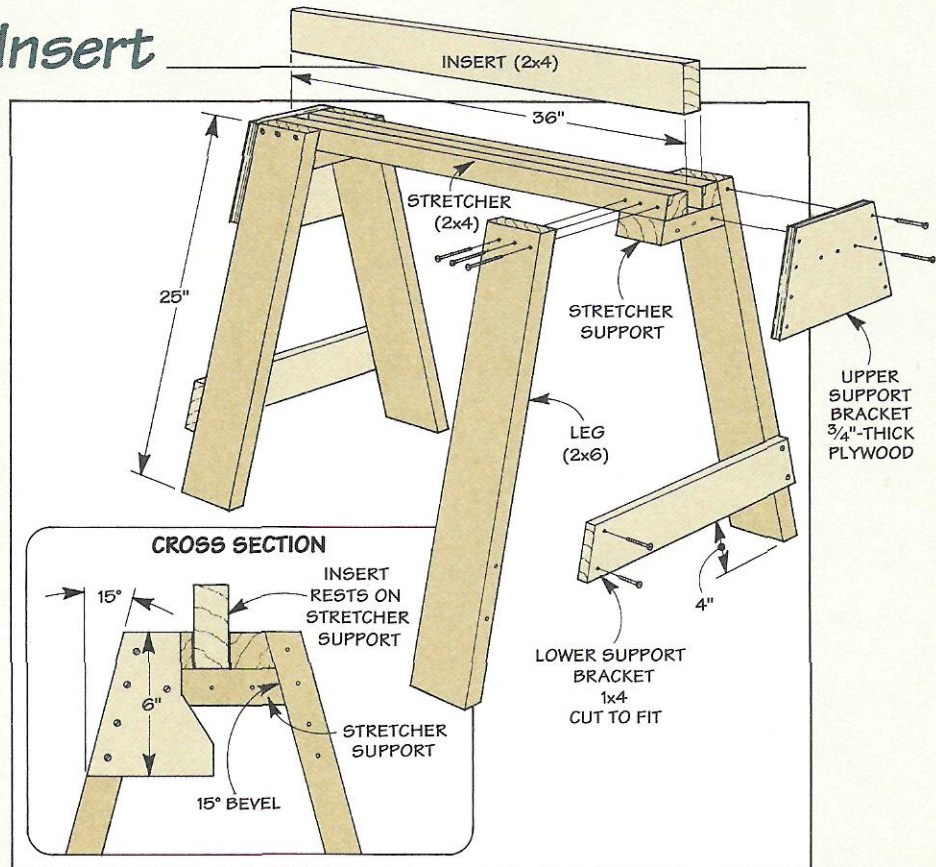

Installing a Strike Plate

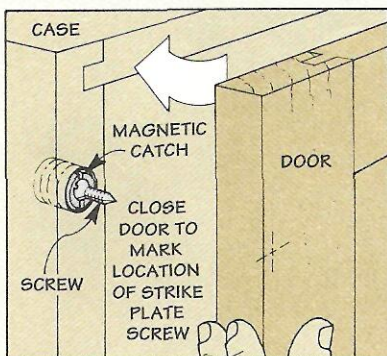

■ When installing a magnetic catch, a quick and simple way to mark the location for the strike plate is to use a screw. After installing the catch, place a short screw in the center of the magnet, see Drawing. Then close the door. The screw marks the door where the plate is to be located.

John Talley
Topeka, Kansas

Send in Your Solutions

If you'd like to share your original solutions to problems you've faced, send them to: *ShopNotes*, Attn: Shop Solutions, 2200 Grand Avenue, Des Moines, IA 50312. (Or if it's easier, FAX them to us at: 515-282-6741.)

We'll pay up to \$200 depending on the published length. Please include a daytime phone number so we can call you if we have questions.

Plywood Veneers

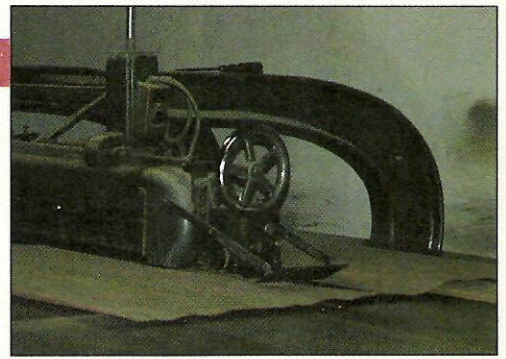

▲ A veneer splicer is used at the plywood plant to edge glue together pieces of flat-sliced veneer into a single sheet.

I recently stopped at a local building center to buy a couple sheets of red oak plywood. As I was flipping through the stack, I noticed the appearance (and price) of the sheets varied greatly — even though they were the same wood. What's the difference?

Jim Niehoff
Riverside, California

The cost and appearance of plywood is affected by how veneer is cut and spliced.

The difference is the thin layer of wood (or face veneer) that's glued to the plywood core. The appearance and price of the plywood will vary depending on how the veneer is cut. Hardwood plywood manufacturers use two basic techniques to cut veneer for plywood: rotary and slicing.

ROTARY CUT

Rotary cut plywood is the most common plywood available (eighty to ninety percent of all veneer is rotary cut). It's made by mounting a log in a lathe and turning it against a razor sharp blade, see Drawing. This way the veneer is "peeled" off the log like paper off a roll of towels.

ROTARY CUT

VENEER IS PEELLED OFF WHOLE LOG

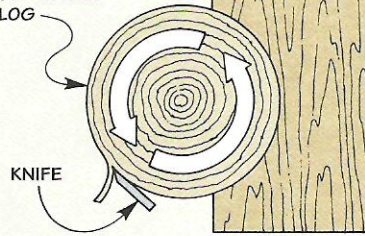

est priced. The only disadvantage is the grain appears widely spaced or "stretched" out, see Drawing. This makes it a good choice for the bottom for a drawer, or the back of a cabinet.

SLICING

With *slicing*, a log is cut in half and mounted onto a frame that moves up and down against a stationary knife, see Drawing.

As they're cut, the veneer slices are kept in sequence so they can be stacked like a deck of

cards in the original order of cutting. Then a variety of patterns can be created by arranging the slices differently, see box below.

When the veneer is spliced together, it resembles glued-up boards. This way you get the look of a wide board without the work.

FLAT SLICED

VENEERS ARE SLICED OFF HALF LOG

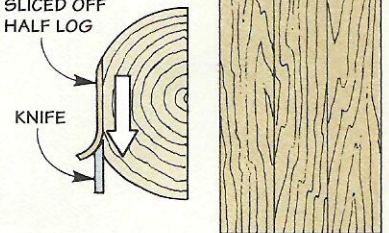

But the slicing process is slow, creates more waste than peeling, and requires work to splice the veneer into sheets, see photo. Because of this, sliced plywood costs forty to fifty percent more than plywood that's rotary cut.

Sliced Veneer Options

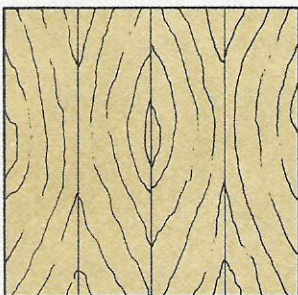

Book Matched: Veneers are opened like the pages of a book for splicing.

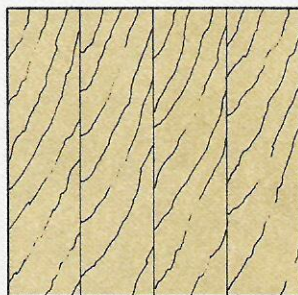

Slip Matched: Each veneer is taken off the "deck" in sequence for splicing.

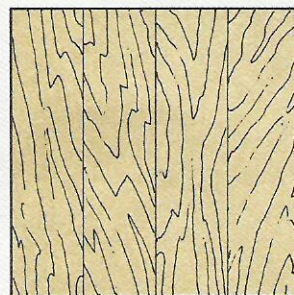

Random Match: No order or pattern is used when veneers are spliced.

Lumber Questions?

Identifying, selecting, and buying materials for your workshop projects can be a bit confusing.

If you have any questions about lumber or other project materials, send them to: *ShopNotes*, Attn: Lumberyard, 2200 Grand Ave., Des Moines, IA 50312.

Please include a daytime phone number so we can call you if necessary.

Sources

ShopNotes Project Supplies is offering some of the hardware and supplies needed for the projects in this issue.

We've also put together a list of other mail order sources that have the same or similar hardware and supplies.

ROUTER BIT STORAGE

The Router Bit Storage Cabinet (shown on page 4) is the perfect way to protect your router bits — and organize them too.

Each bit is stored upright in a shelf that uses a unique holding system. To make it easy to lift bits in and out without binding, each bit slips into a nylon sleeve. In addition, there's a door to keep out dust and dirt. And even a pull-out drawer to store large bits, wrenches, and other accessories.

ShopNotes Project Supplies is offering a hardware kit for the Storage Cabinet. The kit includes all of the hardware necessary to build the cabinet, including nylon sleeves for both 1/4" and 1/2" shank bits (25 of each). All that you need to supply is the 3/4"-thick hardwood and 1/4"-thick plywood.

S13-6813-100 Router Bit Storage Cabinet\$6.95

DUST COLLECTOR

The shop-made Dust Collection System shown on page 14 is a scaled-down version of a commercial model. It features a cyclone separator to remove the big chips. And a filter box to screen out the fine dust.

CYCLONE. The heart of the system is a cyclone. Its unique shape slows down chips and funnels them into a bin. The cyclone consists of a metal cylinder and cone supported by a plywood frame.

ShopNotes Project Supplies is offering a hardware kit for the Cyclone. It includes all the hardware, along with the sheet metal, metal foil tape, weatherstripping, and sealant. (We've also included a full-size pattern for the metal parts.) All you need to supply is plywood and a few pieces of hardwood and Masonite.

S13-6813-200 Cyclone Hardware Kit\$119.95

FULL-SIZE PATTERN. The full-size pattern for the metal parts of the cyclone is available separately.

800-5208 Full-size Pattern for the Cyclone.....\$6.95

FILTER BOX. After the big chips are removed by the cyclone, the

filter box screens out the fine dust. It's just a simple wood frame with cotton fabric stretched around it.

ShopNotes Project Supplies is offering a hardware kit for the Filter Box. It includes all of the hardware and fabric you'll need.

S13-6813-250 Filter Box Hardware Kit\$69.95

VACUUM. The cyclone is designed for a vacuum that moves 500 cubic feet of air per minute. I purchased a *Reliant* 1HP portable dust collector from *Trendlines*. But similar models are available from the sources below.

REMOTE CONTROL. Instead of wearing a path over to the dust collector to turn it on and off, I use a remote control. The one I purchased is made by *X-10*.

You'll need a SR-227 Split Receptacle, and a RC-6500 Wireless Remote Control and Transceiver. (The approximate cost for both of these is \$45.) They're available from the sources listed below.

SCROLL SAW BLADES

The scroll saw blades described in the article on page 8 can be found at many home and building centers. If you can't find them locally, see the sources below.

MAIL ORDER SOURCES

Similar hardware and supplies may be found in the following catalogs. Please call each company for a catalog or for ordering information.

AMI 800-220-4264 <i>Scroll Saw Blades</i>	Penn State Industries 800-377-7297 <i>X-10 Remote Controls</i>	Upper Midwest Satellite 800-637-2398 <i>X-10 Remote Controls</i>
Capital Sales 800-467-8255 <i>X-10 Remote Controls</i>	R.A.L. Technologies 616-538-3028 <i>X-10 Remote Controls</i>	Woodcraft 800-225-1153 <i>Scroll saw Blades</i>
Highland Hardware 800-537-7820 <i>Dust Collectors, Scroll Saw Blades</i>	Sears 800-377-7414 <i>Scroll Saw Blades</i>	Woodworker's Supply 800-645-9292 <i>Scroll Saw Blades</i>
OCS 800-634-4047 <i>Scroll Saw Blades</i>	Trendlines 800-767-9999 <i>Dust Collectors, Scroll Saw Blades</i>	Woodworkers' Store 800-279-4441 <i>Scroll Saw Blades</i>

ORDER INFORMATION

BY MAIL

To order by mail, use the order form that comes with the current issue. The order form includes information on handling and shipping charges, and sales tax.

If the mail order form is not available, please call the toll free number at the right for more information on specific charges and any applicable sales tax.

BY PHONE

For fastest service use our Toll Free order line. Open Monday through Friday, 7:00 AM to 7:00 PM Central Time.

Before calling, have your VISA, MasterCard, or Discover Card ready.

1-800-444-7527

Note: Prices subject to change after March 1, 1994.

Scenes From the Shop

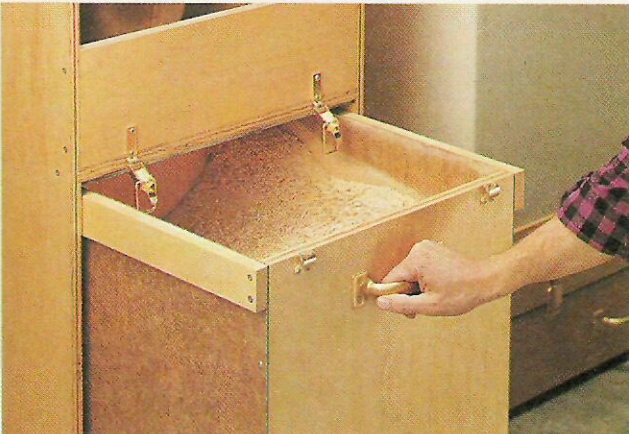

▲ A removable bin collects the large chips that get drawn into the dust collection system. When the chip bin fills up, just release the draw catches and roll it out.



▲ A pair of adjustable elbows connects the vacuum to a large wood frame stretched with fabric. This filter box screens the fine dust particles out of the air.

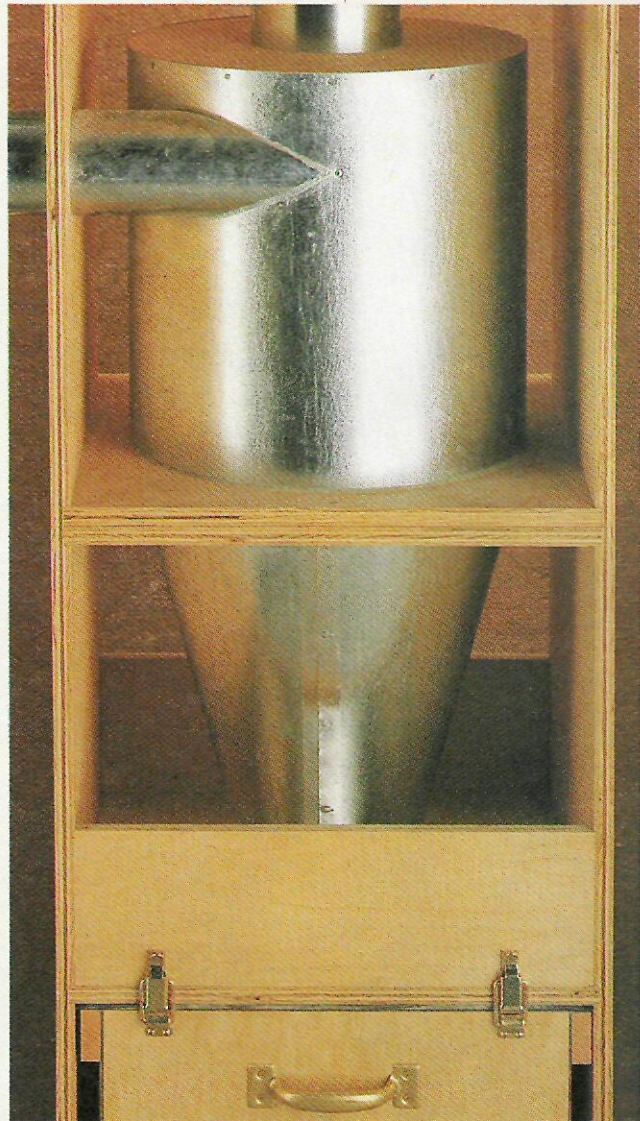

▲ The shape of this metal separator sets up a whirling motion like a cyclone. This funnels the large chips out of the air into a chip bin that sits underneath.



▲ Rather than beat a path between your tools and the dust collector, this remote control switch turns the vacuum on or off with the touch of a button.