

ShopNotes[®]

Vol. 3

Issue 14



FOLD-DOWN WORK CENTER

- Miter Gauge Fence
- Anti-Kickback Router Bits
- Make Your Own Chisel Plane
- Stock Preparation



ShopNotes®

Issue 14

March 1994

EDITOR Donald B. Peschke
EXECUTIVE EDITOR Douglas L. Hicks
MANAGING EDITOR Terry J. Strohmman
ASSOCIATE EDITOR Richard S. Peters
ASSISTANT EDITOR Tim Robertson
CONTRIBUTING EDITOR Philip A. Totten

CREATIVE DIRECTOR Ted Kralicek
ART DIRECTOR Cary Christensen
SENIOR ILLUSTRATOR Kurt Schultz
ILLUSTRATORS Will Niskanen
 Roger Reiland
 Mark Higdon
PHOTOGRAPHER Crayola England

DESIGN DIRECTOR Ken Munkel
SENIOR DESIGNERS Jan Hale Svec
 Kent Welsh
SHOP MANAGER Steve Curtis
SHOP ASST./FACILITIES Steve Johnson

CIRCULATION

Circulation Director: Liz Bredeson • *Subscription Manager:* Phyllis Jessen • *Circulation Analyst:* Rod Cain • *Newsstand Sales:* Kent A. Buckton

PUBLISHING SERVICES

Associate Editor: Gordon C. Gaippe • *Sr. Graphic Designer:* Robert H. Whitmer • *Graphic Artist:* Cheryl L. Cynor

CORPORATE SERVICES

Controller: Robin Hutchinson • *Accounting:* Laura Thomas • *Bookkeeping:* Julie Greenlee • *Production Manager:* Carol Quijano • *Info. Services Manager:* Joyce Moore • *Elect. Pub. Coordinator:* Douglas M. Lidster • *App. Specialist:* Linda Morrow • *Admin. Assistants:* Cheryl Scott, Julia Fish • *Recept.:* Jeanne Johnson • *Building Maint.:* Ken Griffith

PROJECT SUPPLIES

Marketing Director: Robert Murry • *Catalog Art Director:* Cindy Jackson • *Fulfillment Manager:* Valerie Wiese • *Catalog Products Manager:* Bob Baker • *Project Supplies:* Linda Jones • *Technical Support:* Jeff Janes • *Recept.:* Cynthia Kerman

CUSTOMER SERVICE

Supervisor: Jennie Enos • *Customer Service Representatives:* Jennifer Murphy, Joy Johnson, Sara Kono, Anna Cox, Tammi Aldini, Kristi Andrews, Stephanie Hagen

SHIPPING DEPARTMENT

Supervisor: Jerry Carson • *Fulfillment:* Gloria Sheehan, Don McVey, Chuck Carlson, Sylvia Carey

ShopNotes® (ISSN 1062-9696) is published bimonthly (Jan., March, May, July, Sept., Nov.) by Woodsmith Corporation, 2200 Grand Ave., Des Moines, IA 50312.

ShopNotes® is a registered trademark of Woodsmith Corp. ©Copyright 1994 by Woodsmith Corporation. All rights reserved.

Subscriptions: Single Copy, \$4.95. One year subscription (6 issues), \$19.95. Two years (12 issues), \$35.95. Canada/Foreign, add \$5.00 per year.

Second Class Postage Paid at Des Moines, IA and at additional offices.

Postmaster: Send change of address to ShopNotes, Box 11204, Des Moines, IA 50340-1204

Subscription Questions? Call 1-800-333-5854, Sam to 5pm, Central Time, weekdays.

PRINTED IN U.S.A.

EDITOR'S NOTE

It's not unusual to see people wearing hearing protectors around here. We all wear them when working in the shop. But lately many of us have taken to wearing them in the office as well. (As I write this, I'm wearing ear plugs and "ear muff" protectors.)

If you think this sounds funny, believe me, it looks even funnier. But we're not doing this for fun. We're doing it out of necessity. Let me explain.

REMODELING. Like a growing family that needs a larger house, our "family" has grown to a point where we need more room. So a few months back we started a remodeling project.

The plan included adding another floor to the back part of our building, constructing new stairways, and installing an elevator.

Except for a few minor problems (like the backhoe that tried to take a short cut through one of the windows), work seemed to progress quickly. The weather was good. The walls went up, and the new roof went on.

Then winter set in. And when the weather turned cold, work began on the *inside* of the building.

So what does this have to do with wearing hearing protectors? Well, remodeling the inside of the building means lots of drilling, hammering, and cutting — most of it in concrete. And for the last few days the drilling and pounding has been going non-stop. So hearing protectors have become the "in" thing to wear around here.

The surprising thing is, I've heard very few complaints (even without my hearing protectors). Everyone is dealing with the noise and confusion the best way possible. If that means looking a little silly for a while, that's okay.

The end result will be worth it. I'll keep you posted on the progress.

While the new construction has been a bit inconvenient, it hasn't stopped us from putting together a couple of new projects for this issue.

WORK CENTER. Like many of the projects we design, the work center started out as a solution to an everyday problem. In this case, we were looking for a way to provide work space and storage space *without* taking up room.

Our first version wasn't much more than a hinged slab attached to a wall. A good work area, but there wasn't any storage. The second was similar to a locker — lots of storage, but it took up too much space.

It wasn't until we decided to mount it up out of the way on a wall that things started to click. Then we combined both ideas and added a couple of other unique features. The final result is shown on page 16.

CHISEL PLANE. The chisel plane that is shown on page 8 is also a solution to a common problem. But this time it's finding a simple way to clean up hard to reach places like the corners of a drawer, door, or panel.

NEW FEATURE. Projects aren't the only thing new in this issue. We've also added a new feature — the Finish Room. Here we'll take an in-depth look at finishing problems and their solutions. We'll also talk about new products and show tips and techniques for using them. This time we give gel stains a try (see page 30).

NEW FACE. As I mentioned earlier, we're growing rapidly. Carol Quijano is our new production manager. She's here to make sure we're on schedule and the issue is printed on time.

*New construction.
 New projects.
 And a new feature.*

Contents

Miter Gauge Fence _____ 4

Make quick and accurate cuts on the table saw with this shop-built fence for your miter gauge.

Anti-Kickback Bits _____ 6

An in-depth look at how anti-kickback router bits work. Also, a comparison of the different bits available.

Chisel Plane _____ 8

Cleaning up hard to reach places (like the corners of a drawer or panel) is easy with a chisel plane. All it takes to make your own is some simple hardware, a blade, and a scrap of wood.

Stock Preparation _____ 12

The foundation of a quality project can be traced back to how carefully the stock is prepared before the actual building begins.

Fold-Down Work Center _____ 16

This wall-mounted work center offers plenty of built-in storage to keep your tools right at hand. It also features a bench that folds down to provide a solid work surface. And a flip-up door holds an optional shop light.

Drill Press Tips _____ 24

Solutions to some of the most common drilling problems in the shop. Also, simple jigs you can make to increase your accuracy when working with a drill press.

Shop Solutions _____ 28

Five Shop-Tested Tips: Pipe Clamp Caddy, Bench-Mounted Belt Sander, Shop-Made Chisel Holder, Foot Pedal Modification, and a Tip for Mixing Powdered Glue.

Gel Stains _____ 30

The thicker consistency of gel stains offers a number of advantages over liquid stains.

Sources _____ 31

Hardware, project supplies, and mail order sources for the projects in this issue.

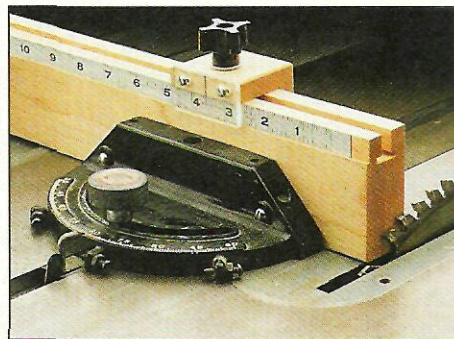

Miter Gauge Fence page 4



Chisel Plane page 8

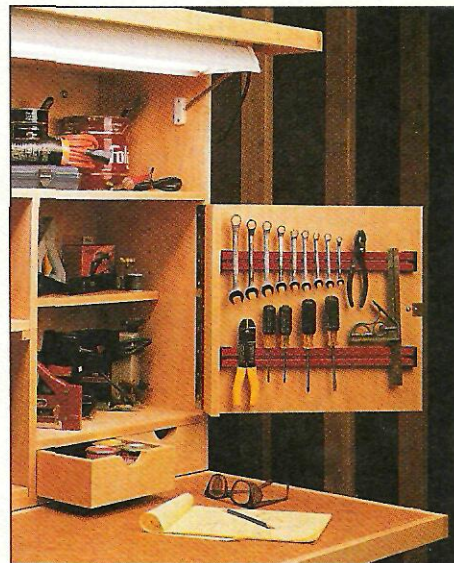

Work Center page 16

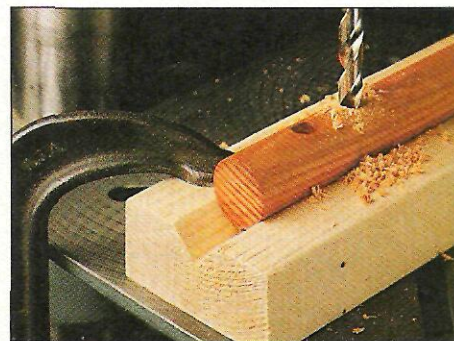

Drill Press Tips page 24

Miter Gauge Fence

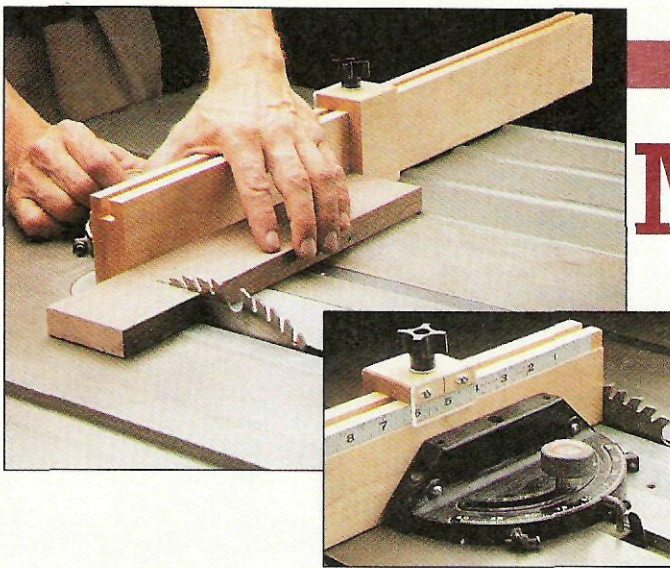

A built-in stop block and measuring tape provide quick and accurate set-ups when crosscutting.

Shop Tip

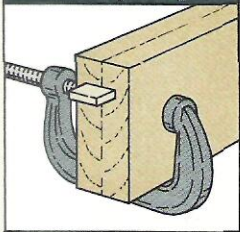

A waxed "key" aligns the kerfs when gluing the fence up the fence.

Like many woodworkers, I attach an auxiliary fence to the miter gauge when crosscutting a board on the table saw. This provides more support for the board than the miter gauge by itself.

But what I like best about an auxiliary fence is you can clamp a stop block to it and cut several pieces to the same length. The only problem is it can be a bit frustrating to clamp the block exactly where you want it.

To set up repeat cuts quickly

and accurately, I made a miter gauge fence with a built-in stop block, see photo. A measuring tape attached to the back of the fence makes it easy to accurately position the stop block, see inset photo.

FENCE. The fence consists of two pieces of $\frac{5}{8}$ "-thick hardwood, see Fig. 1. Although the fence can be as long as you want, make sure it's not so long that it's awkward to use. (I cut each piece 26" long.)

T-SLOT. To allow the stop block to slide back and forth, there's a

T-slot in the top of the fence. The bottom part of this slot is cut before gluing the fence pieces together, see Fig. 1a. To keep these kerfs aligned when gluing up the fence, see tip in margin at left.

When the glue dries, the T-slot can be completed by cutting a centered slot in the edge of the fence, see Figs. 2 and 2a. Next, I cut a shallow rabbet for the measuring tape (Fig. 2b), and chamfered the bottom edges of the fence for sawdust relief.

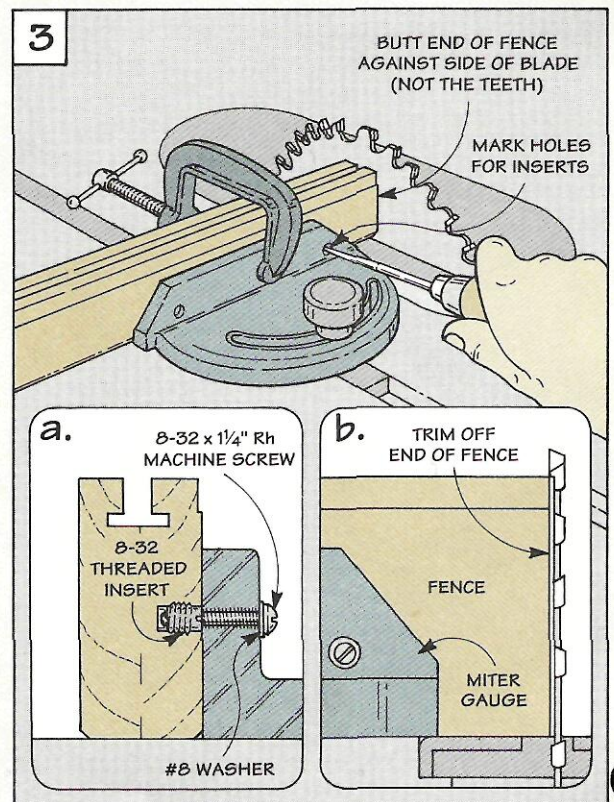
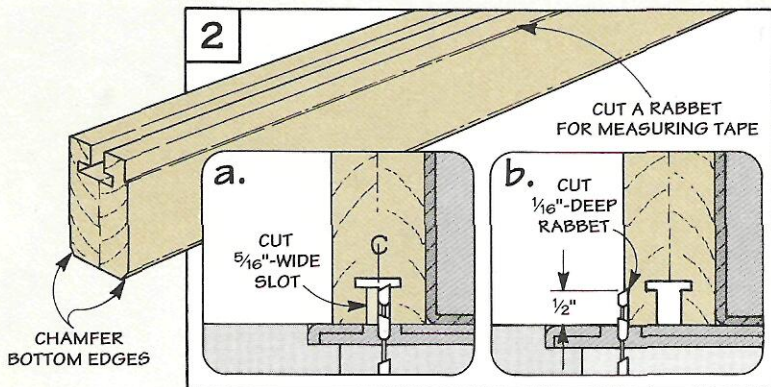
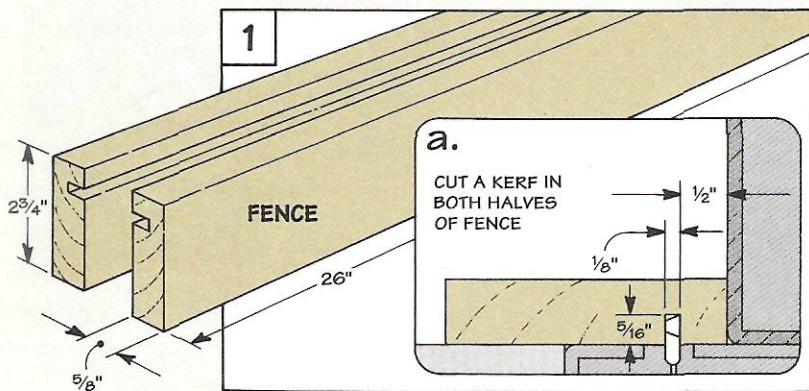

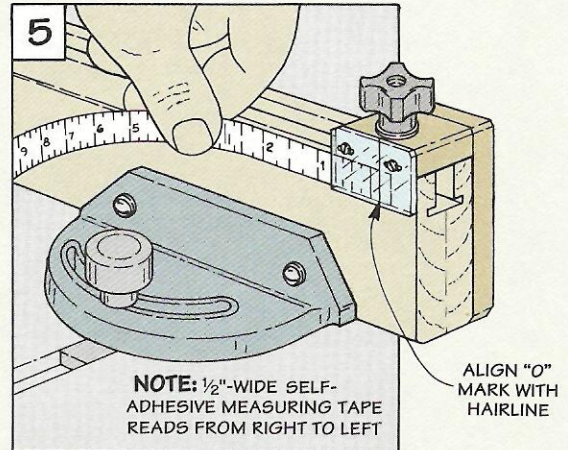
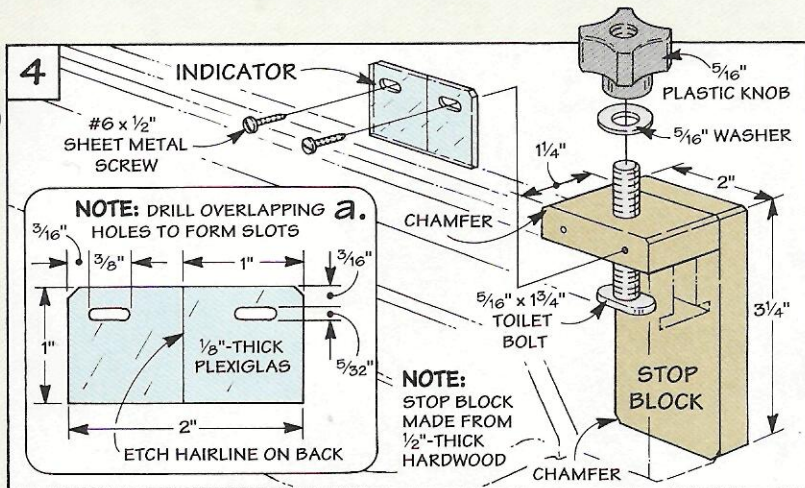

ATTACH FENCE. The fence is held in place with machine screws that pass through the head of the miter gauge and into threaded inserts in the back of the fence, see Fig. 3a.

The location of the holes for these inserts determines the position of the fence on the miter gauge. I wanted the end of the fence to be right up against the blade. This requires shaving off just a bit of the fence *after* it's attached to the miter gauge.

Start by placing the miter gauge in the slot in the saw table. Then, with the fence clamped to the miter gauge so the end butts against the side of the blade (not the teeth), mark the location of the holes, see Fig. 3.

Now it's just a matter of drilling the holes and installing the inserts. After attaching the fence, trim off the end, see Fig. 3b. (To reposition the fence for 45° cuts, see the box at right.)

STOP BLOCK. With the fence in place, the next step is to add the stop block. It's made from two 1/2"-thick pieces of hardwood that are glued together in an L-shape. Both pieces are 2" wide, but their lengths are different, see Fig. 4.

The long (3 1/4") piece hangs in front of the fence and acts as the "stop." Note: The bottom corners are chamfered for sawdust relief. And the short (1 1/4") piece holds the stop block's locking mechanism.

This is nothing more than a toilet bolt that passes through a centered hole drilled in the short piece. When you tighten a knob on the end of the bolt, the head pinches against the T-slot and locks the stop block in place.

INDICATOR. To position the stop block accurately, I added an indicator. This is just a piece of 1/8"-thick Plexiglas with a "hairline" etched in the back side with a utility knife, see Fig. 4a. To make the line easier to see, see tip in margin at right.

To attach the indicator and allow it to be adjusted later, there are two slots near the top. (I made these slots by drilling a series of overlapping holes.) Then, after screwing it in place, I sanded a chamfer on the top edges of the

indicator and stop block.

INSTALL TAPE. The next step is to install the measuring tape. Note: Because I place the miter gauge on the *left* side of the blade, I used a self-adhesive measuring tape that reads from *right to left*, see Sources on page 31.

To install the tape, lock the stop block flush with the end of the fence, see Fig. 5. Then slide the tape under the indicator so the "0" mark aligns with the hairline and press it in place.

FINE TUNING. After trimming off the excess tape, the last step is to "fine tune" the indicator. This requires making a test cut and comparing the length of the piece with the position of the hairline. If necessary, loosen the screws and adjust the indicator.



After filling in the line with ink from a permanent marker, wipe off the excess.

45° Miter Cuts

To keep the blade from cutting through the fence when making a 45° cut, you'll need to reposition the fence on the miter gauge.

This requires adding another pair of threaded inserts. The holes for these inserts are located by tilting the miter gauge to 45°, then positioning the fence so the back corner is 1/16" away from the blade.

Note: Since the tape is set up for 90° cuts, it won't provide accurate readings when making 45° cuts.

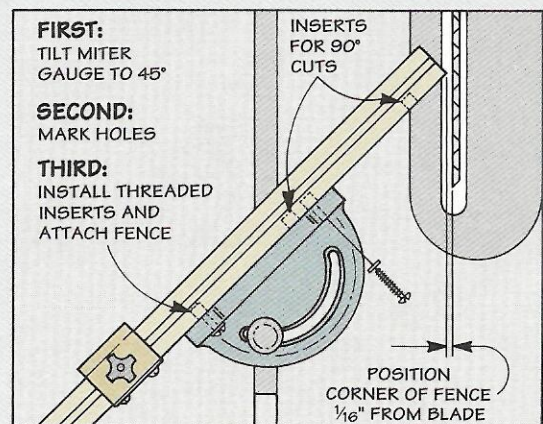

Anti-Kickback Bits

In addition to reducing the chance of a dangerous kickback, the large-bodied design of these anti-kickback router bits offer a number of other advantages.

Any tool or accessory that makes working with wood safer is something I want to know about. So when I first read about router “anti-kickback” bits, I was intrigued.

WHAT'S DIFFERENT?

The most noticeable difference between an anti-kickback router bit and a conventional router bit is the *shape*, see Drawings below.

On a conventional router bit, the carbide cutters are supported by a pair of thin steel wings, see Drawing below left. But on an anti-kickback bit, the cutters are attached to a large body that wraps around in *front* of the cutter, see Drawing below right.

THE GULLET. Basically this reduces the gullet (opening) in front of each cutter. By creating this “shoulder,” you limit the size of the chip that you can take. In fact, these bits are often referred to as chip-limiting bits.

DO THEY WORK? Since the gul-

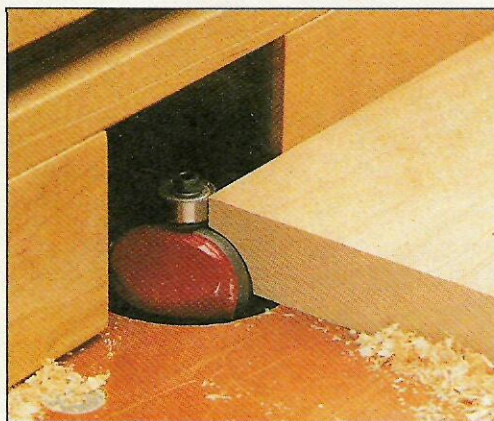

let in front of each cutter is smaller, I assumed that I'd have to feed the workpiece *slower*. But I didn't. There wasn't any noticeable difference in feed rate between an anti-kickback and a conventional router bit when I tested them.

ANTI-KICKBACK FEATURE

Now I was a little confused as to just how the anti-kickback feature worked (if it doesn't limit the feed rate). To find out more information about these router bits, I gave Jim Brewer (Research and

Marketing Manager) at Freud a call.

He said that the anti-kickback bits won't limit your feed rate under *normal* circumstances. But that the anti-kickback feature only really figures in when something *unexpected* happens.

CONVENTIONAL BIT. For example, say you're getting ready to rout the edge of a workpiece with a conventional router bit. If you were

to accidentally slip and jam the workpiece into the bit, you could force it in between the cutters, see Fig. 1.

If this were to happen, the cutter would slam into the workpiece, taking a large bite. And the resulting force would create a dangerous kickback.

ANTI-KICKBACK BIT. With an anti-kickback bit, the workpiece would actually ram the *shoulder* and only a small chip would be removed, see Fig. 2. And the force of the kickback (if any) would be *greatly* reduced.

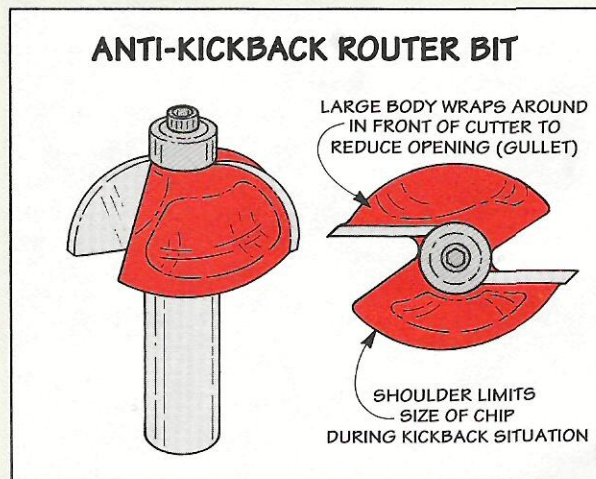
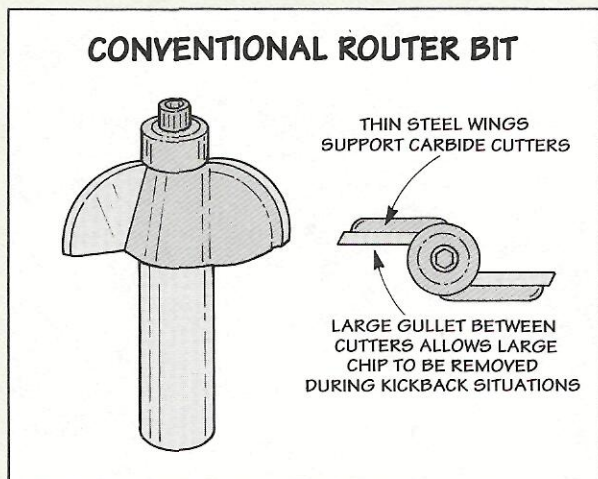

This is particularly important with a larger bit (like a horizontal raised panel bit). The larger the bit is, the greater the possibility of a kickback. And the more forceful and dangerous the kickback can be.

Another case where these bits can reduce kickback is if you were to hit a knot. When this happens, the knot can break free and slam back into the bit. With an anti-kickback bit, the knot would hit the shoulder — reducing kickback.

ARE THEY ALL THE SAME?

Once I understood how the anti-kickback feature worked, I tested bits from four companies (CMT, Freud, Leichtung, and Oldham) to see how they would perform in a kickback situation.

Although, none of the bits eliminated kickback completely, they did reduce the force of the kickback *considerably* if it did occur.

What I didn't expect was that the large-bodied design also helped to dampen vibration. And because of this, all of the bits that I tested ran smooth and chatter free.

DIFFERENCES. At first glance, all of the bits look the same, see photos below. But on closer in-

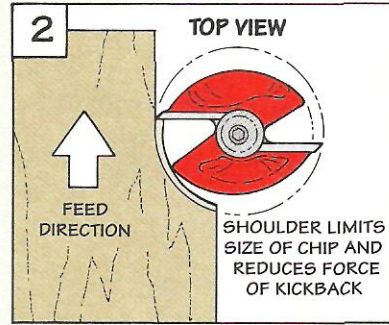
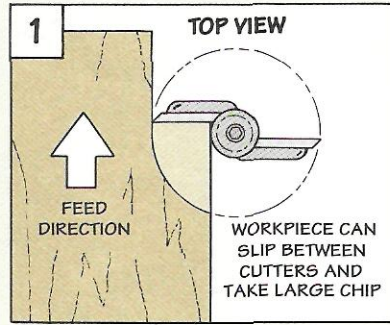

spection, I noticed the bits manufactured by Freud were different.

When you look at one straight on, the cutting edge protrudes past the shoulder a *uniform* distance (about 1/16"), see Drawing below. On the other bits, the

PROFILES

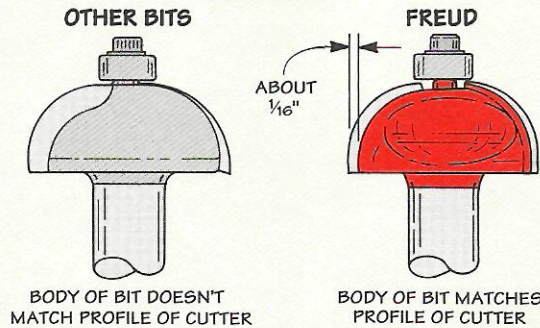

shoulder doesn't match the cutter profile exactly.

So what? According to Freud, this means their bits will take a smaller bite in a kickback situation. Which means the force of the kickback should be less. In

theory, I'm sure this is so — I just hope I never have to find out.

OTHER BENEFITS. In addition to reducing kickback and running smoother, the large-bodied design of these bits also helps to dissipate heat faster and keep them cooler. And in the long run, this can prevent the bit from getting too hot and burning (or even losing its sharp cutting edges).

ARE THEY WORTH IT?

If I were in the market for a new bit (or a set of bits), I'd buy bits that offer the anti-kickback feature. (Note: Most anti-kickback router bits are available with either 1/4" or 1/2" diameter shanks.) They don't cost any more than other high-quality carbide router bits. And when it comes to safety in the shop, every little bit helps (pun intended).

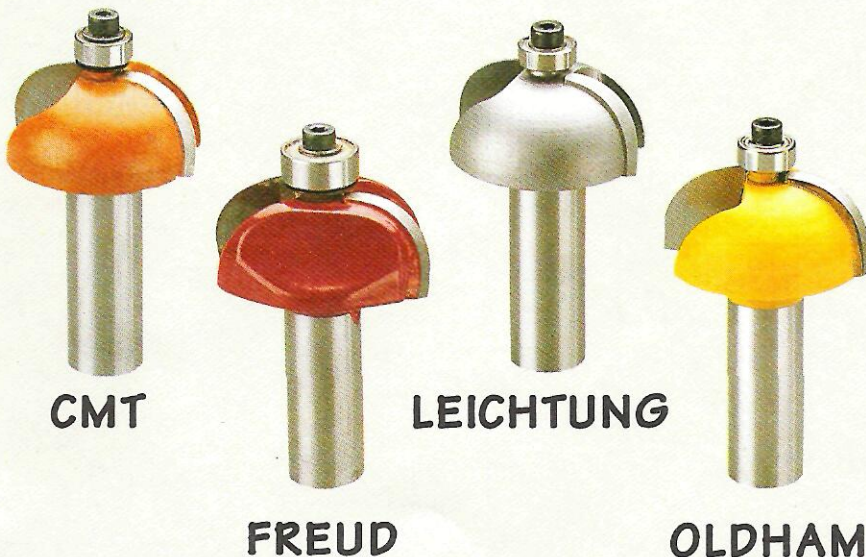

◀ **Anti-Kickback Bits:** I tested router bits from four different companies: CMT, Freud, Leichtung, and Oldham/U.S. Saw. All of these bits offer a large-bodied design that runs smooth and chatter free.

Some of the bits (CMT, Freud, and Oldham) also feature a colorful anti-stick heat resistant coating that makes them more visible. And at the same time helps to keep the bits clean and cool.

Chisel Plane

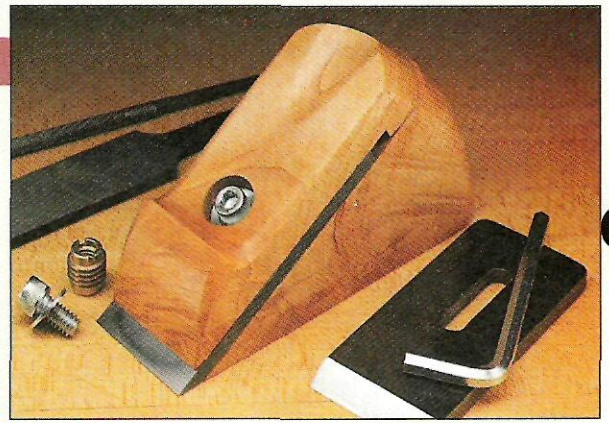

A blade that extends in front of this chisel plane lets you work into hard-to-reach corners.

Sometimes when you need to plane into a tight corner, an ordinary hand plane just won't "cut" it. What happens is the front of the plane bumps into the workpiece and stops the blade short.

The solution is a special type of plane where the blade sticks out in front of the body like a chisel.

This lets you get into hard-to-reach places without having the body of the plane get in the way. The only drawback to these chisel planes is the cost — \$75 and up. So rather than buy one, I decided to make my own, see photo.

BLADE. As with any plane, the important thing is to start with a

good blade. I used a 1½"-wide blade manufactured by the Hock Company, see page 31 for sources.

TWO PARTS. Basically, this chisel plane consists of two parts: a wedge-shaped body that supports the blade, and a cap to hold the blade tight against the body, see the Full-Size Patterns at left.

Editor's Note: To use the patterns without cutting them out of the issue, you can reproduce them on a photocopy machine and then cut the pieces apart.

BODY. Now work can begin on the body of the plane. To match the width of the blade, I started with a 1½"-thick hardwood blank (maple). Then I attached the pattern with spray adhesive so the sole (bottom) is flush with the edge of the blank, see drawing above left.

SLED. Once the pattern is attached, the challenge is to safely cut the steep angle of the body. To do this, I used a Masonite "sled" that carries the blank through the saw blade, see Fig. 1.

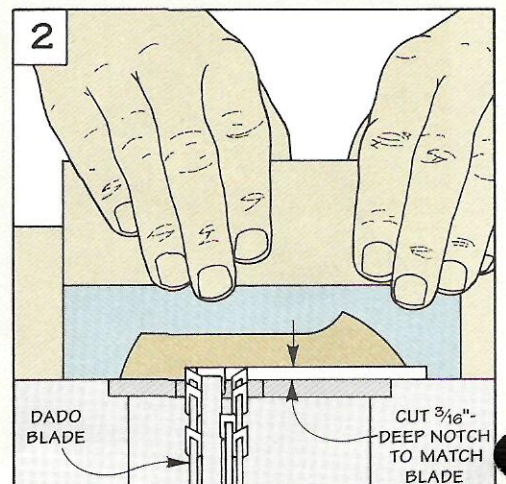
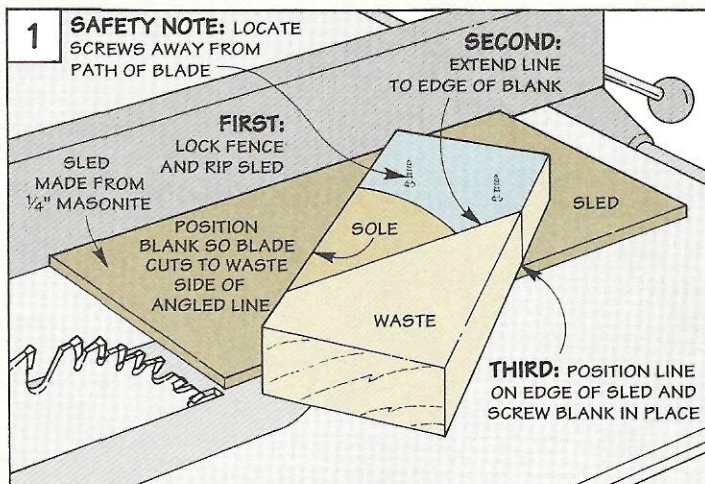
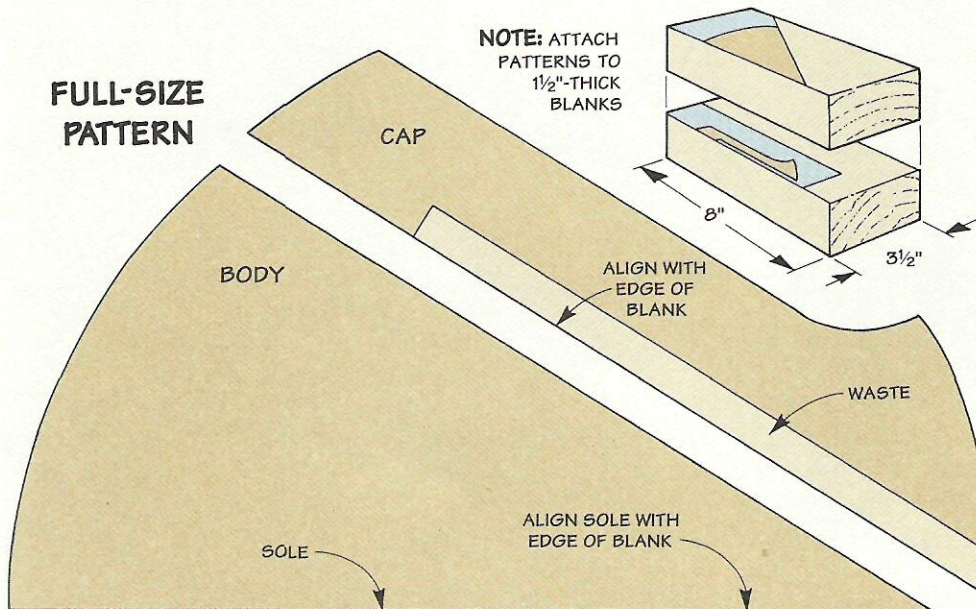

This requires positioning the blank on the sled so the saw blade cuts to the *waste* side of the angled line on the pattern, see Fig. 1. To do this, I ripped the sled to a width of about 7" and used the edge as a reference to indicate the path of the blade.

Now it's simply a matter of aligning the angled line with the edge of the sled. Note: You'll need to extend this line to the edge of the blank. Then screw the blank to the sled and make the cut.

To complete the rough shape of the body, I cut the gentle curve on the back with the band saw.

CAP. Now you're ready to make the cap. Here again, the pattern is glued to a 1½"-thick blank. To fit the cap over the blade, I cut a notch in the bottom that's the same height (⅜") as the thickness

EXPLODED VIEW

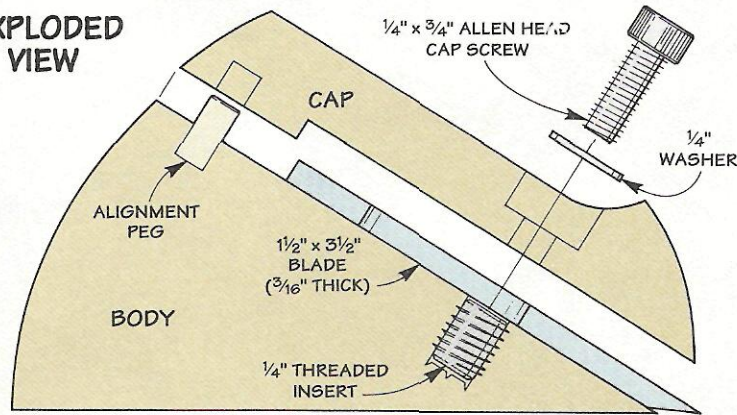

of the blade, see Fig. 2. Then, like the body, the cap is cut to rough shape on the band saw.

MOUNTING SYSTEM

This chisel plane is designed with a simple, yet effective system to hold the blade tight against the body.

CAP SCREW. The key to making this work is an Allen head cap screw. It passes through a hole in the cap and tightens into a threaded insert in the body, see Exploded View.

CRADLE. The trick is to get the hole in the cap aligned with the hole for the insert. To do this, I made a "cradle" that prevents the pieces from slipping around when drilling. The cradle is just a scrap

2x4 with the shape of the body cut out of it, see Figs. 3 and 4.

DRILL HOLES. Once the cradle is complete, you can drill the holes. Start by laying out the location of the hole on the side of the body, see Figs. 4 and 4a.

Before extending this line to the cap, I fit a spacer in the notch for the blade and carpet taped it between the cap and body.

After slipping this assembly into a tall fence, the next step is to drill a counterbored shank hole in the cap. Then simply remove the cap and drill a hole in the body for the threaded insert, see Figs. 5 and 5a. Note: While the setup was in place, I installed the threaded insert, see tip in margin.

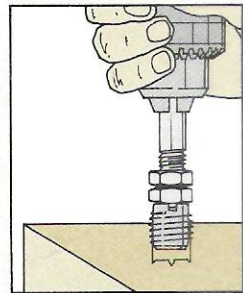

I use a cut-off bolt chucked in a drill press to turn a threaded insert in by hand.

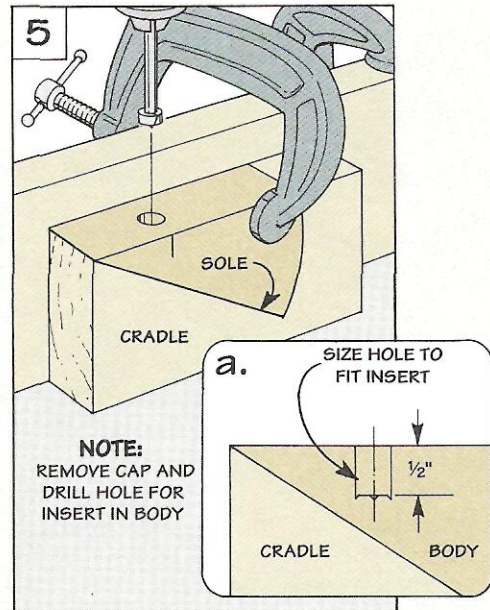
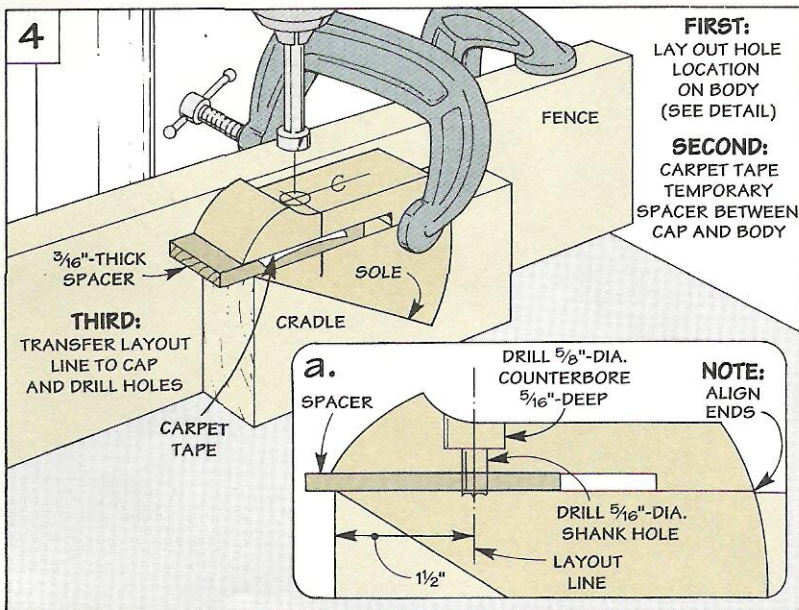
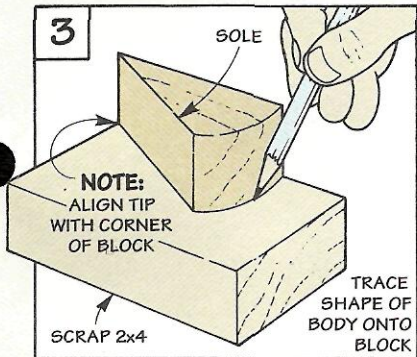

Alignment Peg

After installing the insert, the next step is to add an alignment peg. This peg provides a quick way to position the cap on the body. And it keeps the cap from spinning when you tighten the screw into the insert.

DOWEL. The alignment peg is just a hardwood dowel that sticks up above the body, see Fig. 6. A mating hole in the bottom of the cap allows it to fit down over the end of the peg.

ALIGN HOLES. To make this work, the holes in the body and the cap need to line up. This is a simple two-step process. First, the hole for the peg is drilled in the body. Then it's used to help locate the corresponding hole in the cap.

There's no need to move the fence when drilling the hole for the peg. And you can use the same cradle as before. Only this time, slide it along the fence to reposition the body of the plane under the drill bit, see Fig. 7. Then just drill a shallow hole for the dowel, see Fig. 7a.

DOWEL CENTER. To align the mating hole in the cap, I used a dowel center, see Fig. 8. The trick is positioning the cap so the point of the dowel center "dents" it in the right place, see Fig. 8a. To do this, I used the spacer again and

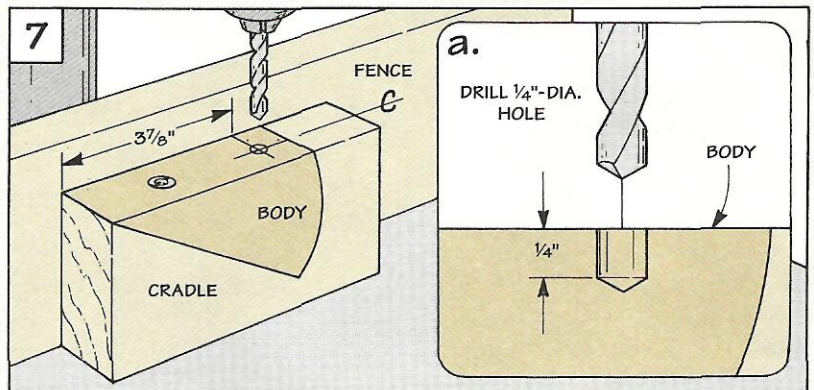
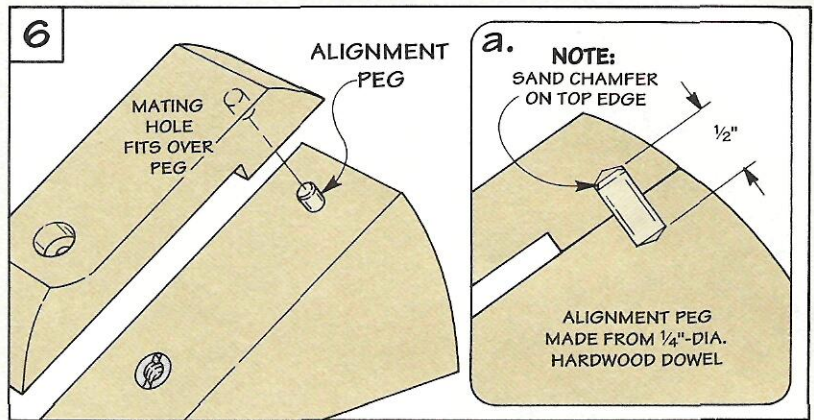

tightened the cap down over it with the Allen screw.

DRILL HOLE. Once the location is pinpointed, you can drill the mating hole. The problem is the finger stop on the cap prevents it from sitting flat on the drill press table. To keep it from rocking, I supported the flat end of the cap

with a piece of plywood while drilling the hole, see Figs. 9 and 9a.

INSTALL PEG. After cutting a short (1/2") length of dowel, the peg is simply glued into the hole in the body. To make it easy to fit the hole in the peg, I sanded a slight chamfer on the top edge, refer to Fig. 6.

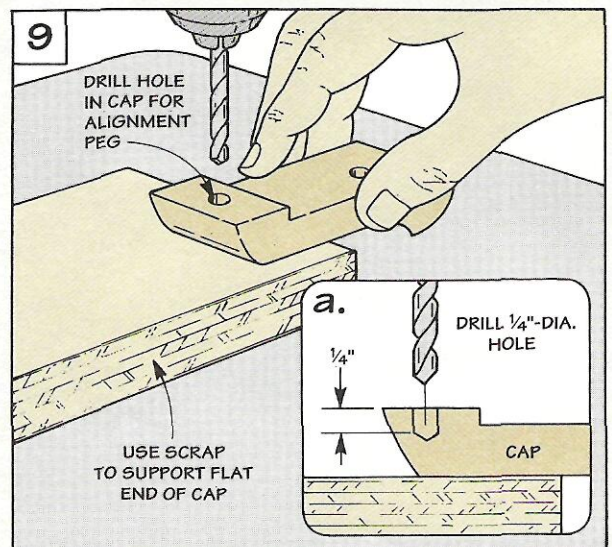
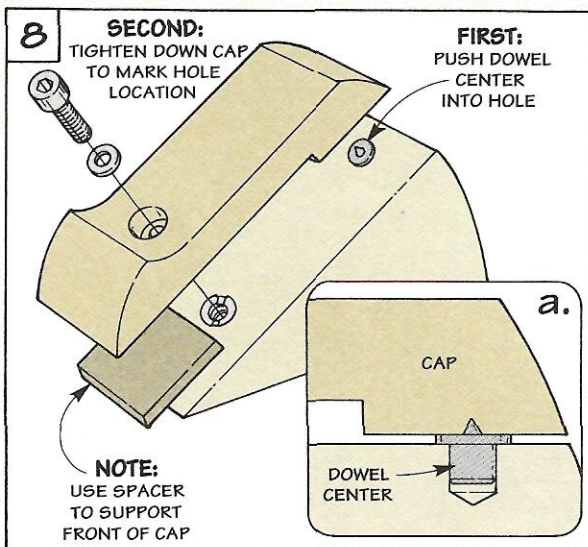

Final Shaping

All that's left to complete the plane is a bit of final shaping.

CROWN. To provide a comfortable grip, I filed a gradual "crown" on the back of the plane, see Crown Detail and Fig. 10. But first, I tightened the cap down to ensure that the curve on the body matches the one on the cap.

Note: To raise the plane to a comfortable working height, clamp it in a handscrew that's tightened in a vise. This setup also works well when sanding the end smooth, see Fig. 11.

FINGER RECESS. Next, I made a recess in the top of the cap to provide a resting place for my index finger, see Figs. 12 and 12a. Here, I removed most of the material with a round file. Then I used a dowel wrapped with sandpaper to remove the file marks.

CHAMFER EDGES. The final shaping is to chamfer the edges. I filed and sanded a *tapered* chamfer on the top edges of the cap, see Fig. 12. This chamfer is *widest* at the finger stop, then narrows toward the front and back.

There's also a chamfer where the cap and body meet at the back of the plane, see Figs. 12 and 12a. This chamfer "wraps" around the back of the plane and stops where the notch for the blade begins.

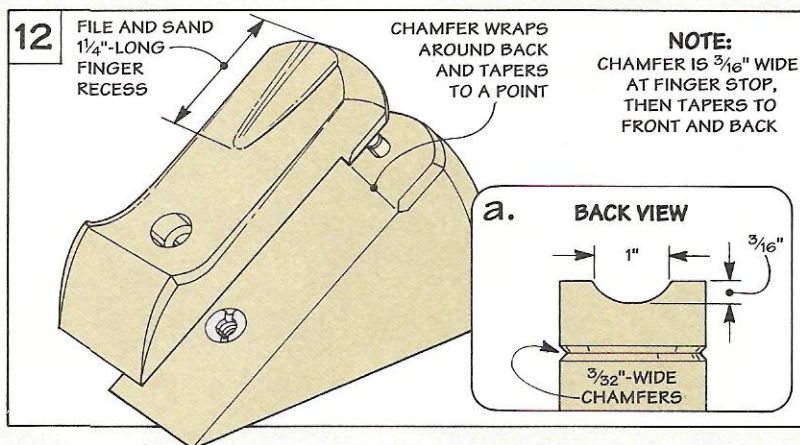
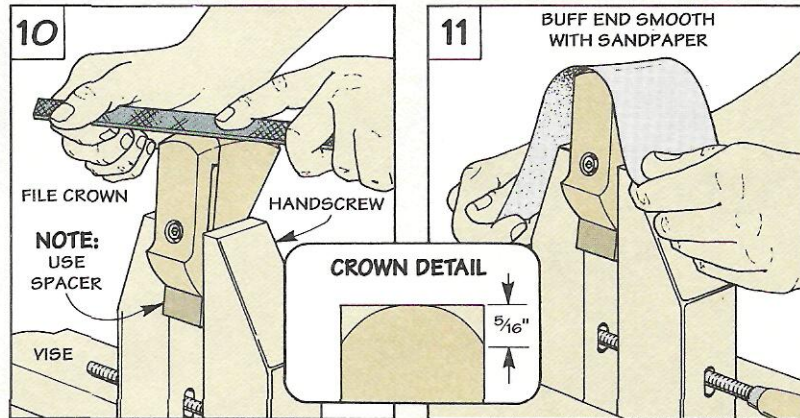

ASSEMBLY. Assembling the plane is easy. Just sandwich the blade between the cap and body, and tighten the cap screw so it's snug. The trick is to adjust the blade to produce a fine shaving.

ADJUSTMENT. What I found worked best is to start with the

plane on a flat board so the cutting edge is flush with the sole, see Figs. 13 and 13a. Then tighten the cap down with an Allen wrench and make a test cut. If you need to readjust the blade, "nudge" it down so the cutting edge is just a hair below the sole.

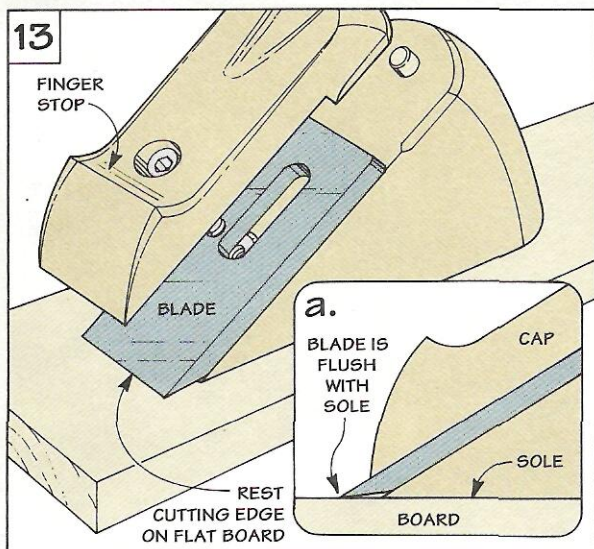

Using the Chisel Plane

There are a couple of things to keep in mind when using the chisel plane.

HAND POSITION. To make a cut, grasp the plane and push forward with the palm of your hand. At the same time, use the finger stop to apply downward pressure on the blade.

SHORT STROKES. Instead of making a long pass, I've found that short, paring strokes work best to produce a smooth cut.



Use short strokes and apply downward pressure on the cutting edge to pare off a thin shaving with the chisel plane.

Stock Preparation

What's the secret to a successful project? Starting with the surfaces of each board flat, straight, and square to each other.



It's no secret that working with stock that's flat, straight, and square makes building a project easier. Nevertheless, it's one of the things that often gets overlooked in the early stages of a project.

Like the actual building of the project, careful stock preparation doesn't just happen by accident. It requires time and planning. To ensure accurate results, I follow a simple five-step process, see the box below and pages 13 through 15.

WAIT. It's tempting to start right in as soon as you haul the boards into the shop. But there's one thing I always do first — *wait*. The reason for this is simple. It gives the wood some time to adjust to the moisture level of the air in the shop. This way, if there's a problem with the board caused by the movement of the wood (say it checks for example), you can plan around it when laying out the pieces.

To ensure that the wood adjusts evenly, I "sticker" the boards. This is nothing more than stacking the boards with strips of wood in between to allow air to circulate on all four sides, see photo below.

LAYOUT. After waiting for the wood to adjust (about a week or two), you can begin laying out the pieces of the project. To get the best use out of each board, I lay the pieces out around two things: the figure (grain) of the wood, and defects in the board (like sapwood or knots), refer to Fig. 1 on the opposite page.

Once you've decided the best way to lay out each board, make a chalk (or pencil) mark to identify the pieces, see the photo above. Just be sure to allow a bit "extra." As a rule of thumb, I lay out the pieces about 1" *wider* and 2" *longer* than their finished size.

One exception to this rule is if the project involves a lot of small pieces. In this case, I group them together as a single "piece." This saves time by not having to machine each piece separately. And the larger pieces are safer to work with.

TEST PIECES. Another thing I like to do when preparing stock is to make a number of test pieces that are the same thickness (or width) as the "real" pieces. These pieces come in handy when setting up your tools. And they allow you to check the fit of a joint before cutting the project pieces.

Step-by-Step

- 1 Cut to Rough Size.** Lay out the project pieces on the board to allow for extra length and width. Then cut them to rough size.
- 2 Joint One Face.** Use a jointer to get one face perfectly flat. This face becomes a reference for the remaining surfaces.
- 3 Joint One Edge.** To produce an edge that's straight and square, run the face that's flat against the fence on the jointer.
- 4 Thickness Stock.** A planer reduces the thickness of the board and creates a face that's flat and parallel to the jointed face.
- 5 Cut to Finished Size.** True up the final edge by ripping the board to width on the table saw. Then cut the piece to length.



Stacking the boards with small strips in between allows the wood to adjust to the moisture level of the air in the shop.

Cut to Rough Size

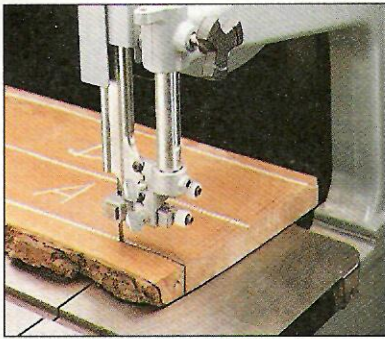

To make the pieces more manageable and easier to handle, cut them to rough size using the chalked layout lines as a guide.

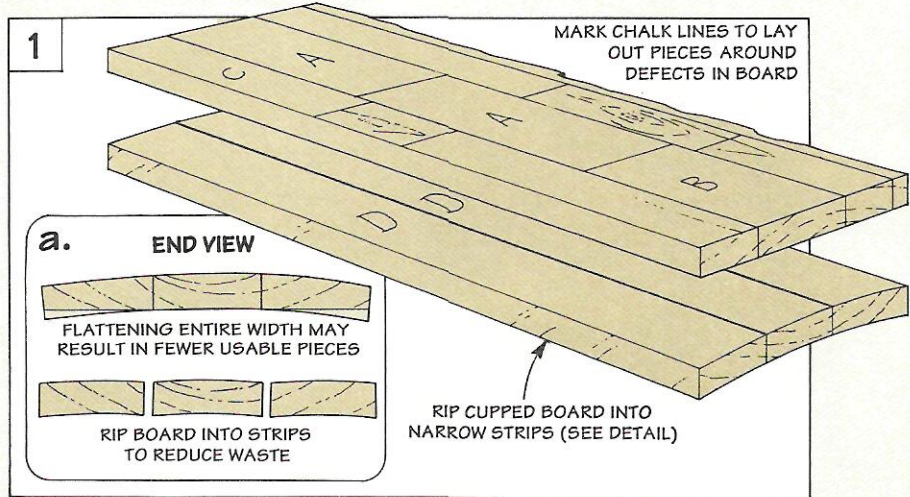

■ The first step is to use the layout lines to cut the pieces to rough size. Depending on how the pieces lay out, I use a band saw (or sabre saw) to rip them to rough width. And a radial arm saw (or circular saw) works well

to cut them to rough length.

Regardless of the tool you use, rough cutting lets you work around the knots or other defects in the wood, see Fig. 1. But more importantly, it increases the amount of *usable* wood.

Take a board that's cupped for example. To remove the cup across the entire width of the board would waste a lot of material, see Fig. 1a. But if the board is first ripped into narrow pieces, there's less waste.



Joint One Face

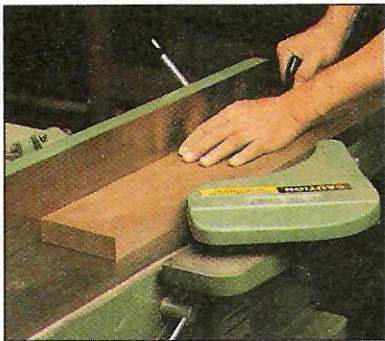

Use a jointer to get one face flat. This lays the groundwork for a board with surfaces that are flat, straight, and square.

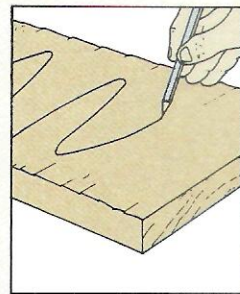
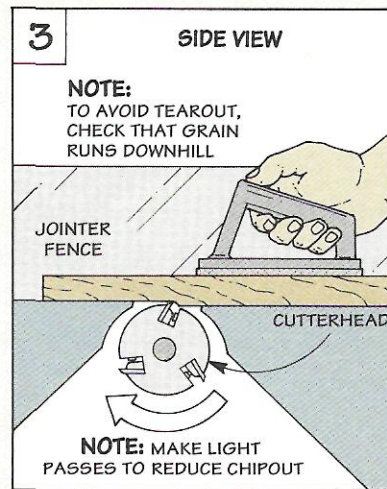
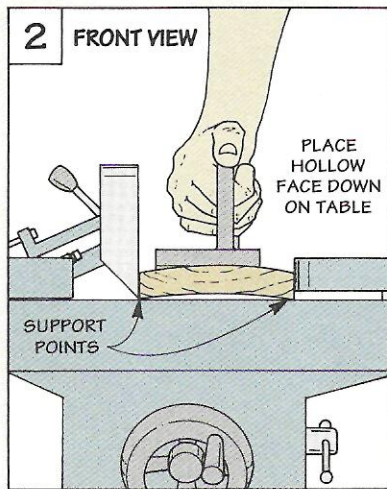

To tell when the face is flat, scribe a line across the board and continue jointing until all the marks disappear.

■ Getting one face of each board flat is the "cornerstone" of stock preparation. That's because this face serves as a reference for squaring up the rest of the board.

JOINTER. Although you can use a hand plane to create this flat surface, a jointer saves a lot of time and energy. Still, there are a few things to keep in mind before

you joint the face.

CUPPED BOARD. If the board is cupped, I place the "hollow" face down on the bed, see Fig. 2. This provides two support points which keep the board from rocking.

GRAIN DIRECTION. Another thing to be aware of is the grain direction. I feed the board into the cutterhead so the edge grain

runs "downhill," see Fig. 3. This way, the jointer knives won't catch the wood fibers and cause tearout.

DEPTH OF CUT. A clean cut also depends on the *depth* of cut. A series of light passes ($1/32$ ") works better than trying to remove a lot of material with a single cut. Also, there's a simple tip to tell if the surface is truly flat, see margin.

Joint One Edge

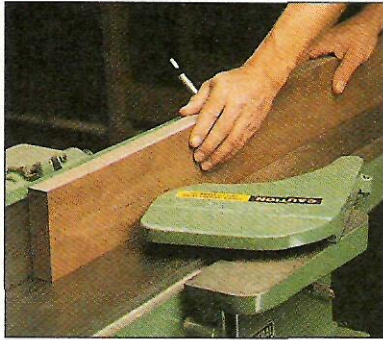

To produce an edge that's straight and square, run the face of the board that's already flat against the fence on the jointer.

■ Once the face is flat, the next step is to joint one *edge* of the board. The goal here is to create a straight edge that's 90° to the face you've already jointed.

To produce a square edge, check that the fence is 90° to the table. Then, with the flat face against the fence, apply pressure in *two* directions at the same time — *inward* against the fence, and *downward* against the table, see Fig. 4.

GRAIN DIRECTION. As before, feeding the board into the cutterhead so the grain runs down-

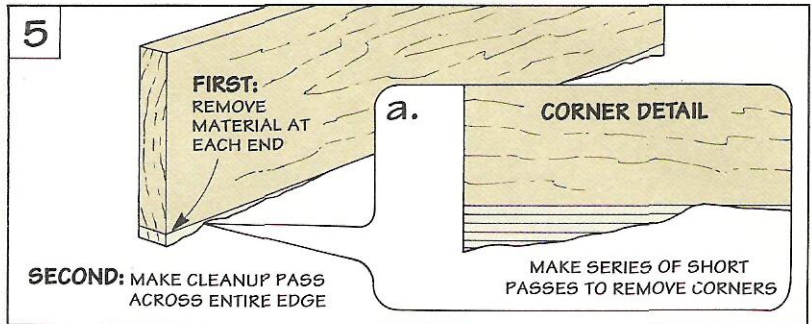
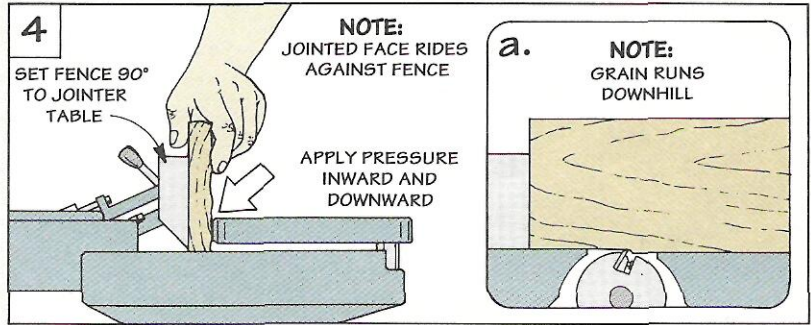

hill helps reduce chipout. But here, I check the grain direction on the face of the board, see Fig. 4a.

The only problem is when the grain changes direction in the middle of the board. To get a clean cut, I set the jointer for a *very* light pass and feed the board slowly across the cutterhead.

CROOKED EDGE. Another thing that often crops up is a board that has a particularly crooked edge, see Fig. 5. In this case, I make several short passes to nibble off the “corners” at each end. Then, make a final cleanup pass (or passes) across the entire length of the edge, see Fig. 5a.

Ripping Jig

If the edge of a board is especially crooked (or you don't have a jointer), you can *rip* a straight edge on the table saw.

Because there's no straight edge to run against the rip fence, this requires a simple jig. This is nothing more than a plywood “sled” that carries the board through the saw blade, see Drawing.

To position the board, the idea is to use the *edge* of the sled as a reference that shows where the blade will cut through. To do this, start by ripping the ply-

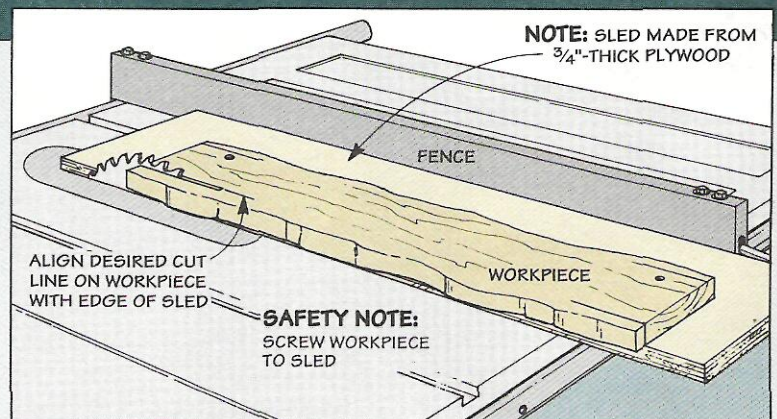

wood so it's wider than the workpiece. Then (without moving the rip fence), position the workpiece so the edge you want to

remove hangs over the plywood.

To attach the workpiece securely to the sled, I fasten it in place with screws.

Thickness Stock

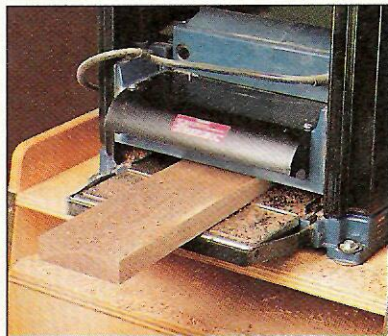

A planer not only reduces the thickness of the board. It creates a face that's flat and parallel to the jointed face.

■ With one edge straight and square, you can concentrate on the one remaining face. What you're looking for here is a flat surface. But to make the board a uniform thickness, this surface also needs to be parallel to the opposite face.

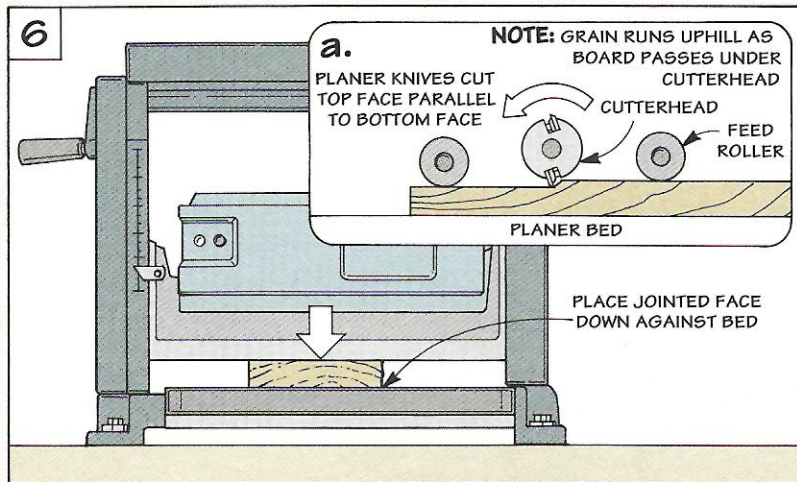

PLANER. The ideal tool for this job is a thickness planer. As the bottom (flat) face is held tight against a machined bed, the planer knives cut the top face flat and parallel, see Fig. 6. To get a clean cut, the edge grain should

run uphill as the board passes under the cutterhead, see Fig. 6a.

Shop Tip: Plane all the boards of the same thickness at one setting before changing it. Then add thinner boards into the works as you adjust the depth of cut.

Cut to Finished Size

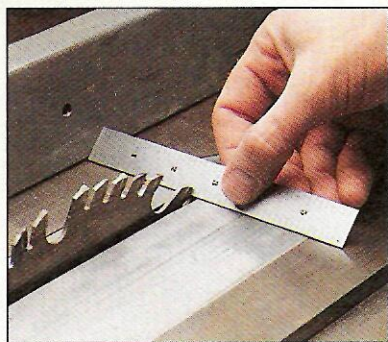

After locking down the rip fence the same distance away from the blade as the desired width of cut, rip the board to final width.

■ The last step is to cut each board to finished size. First the width, then the length.

WIDTH. Cutting the boards to width is simply a matter of ripping them on the table saw. Just make sure to run the jointed edge against the rip fence, see Fig. 7.

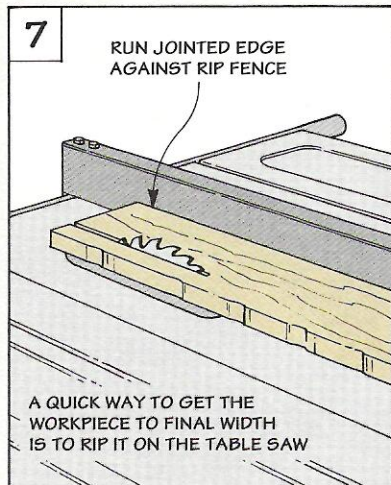

The problem is the blade sometimes leaves saw marks or burns the edge. These marks can be removed by sanding or scraping. But a quicker way is to use the jointer.

In this case, I rip the board so it's $\frac{1}{32}$ " wider than the final width. Then make a light pass on the

Planing an Edge

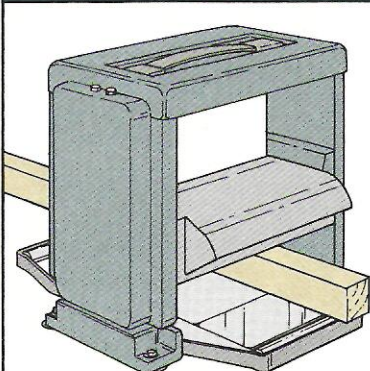

Sometimes you can use a thickness planer to trim a board to width. **Safety Note:** To keep the workpiece from tipping, I only do this with pieces that are nearly square.

jointer. (For an alternative method, see the box above.)

LENGTH. Now all that's left is to trim each board to its finished length. To do this, I start by squaring up one end. Then square up the opposite end as you cut the board to length.

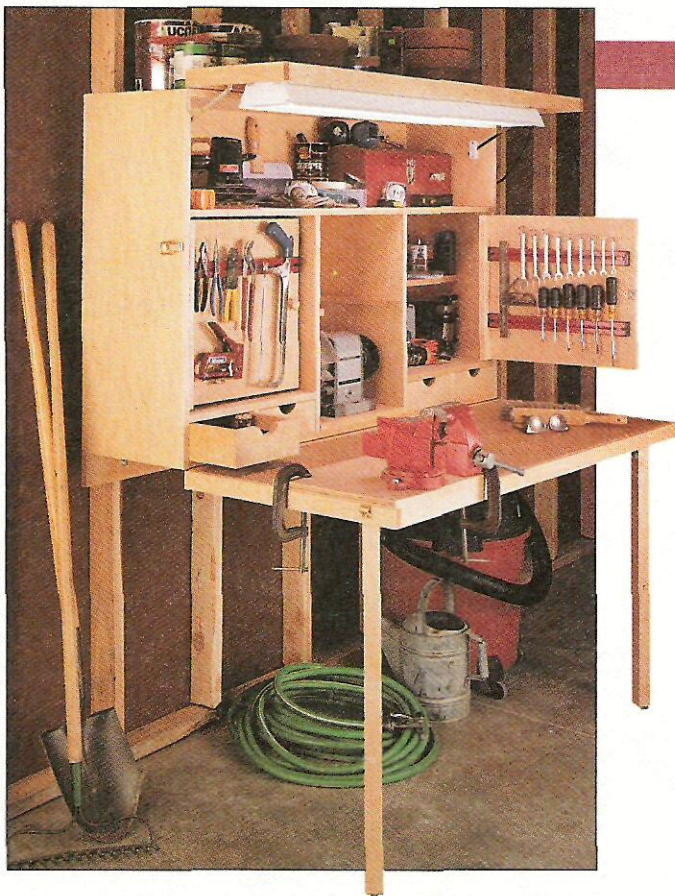

Fold-Down Work Center

A wall-mounted work center that takes up little space but offers lots of storage. And a fold-down bench that provides a large work surface.

even an extra work center in the shop for sanding, clamping, or finishing. The possibilities are almost endless. (See the back cover for some examples.)

FOLD-DOWN. To take up minimal space wherever it's used, this work center mounts up out of the way on the wall, see photo on bottom of page 17. When it's time to work, the front folds down to create a large, stable workbench, see photo at left.

STORAGE. To keep your tools right at hand, there are a pair of tool boards that swing out for easy access. Inside the case there are shelves and tool platforms designed to hold a vise, grinder, or other tools. There's even a set of drawers to help organize hardware, tools, and accessories.

SIMPLE CONSTRUCTION. And best of all, this fold-down work center features simple, straightforward construction. So in no time, you can have a compact work center for almost any purpose wherever you need one.

The reaction to this project was surprising. Although we originally designed this work center for a garage (where you need a work surface but don't have a lot of extra space), some of the guys in the shop had some different and interesting ideas.

Ken, our Design Director, said it was the perfect size for model making. And Steve, the Shop Manager, commented that it would be great for carvers. Others mentioned using it as a potting station or

Materials & Hardware

Case

A Top (1)	13 ³ / ₄ x 58 ¹ / ₄ - ³ / ₄ ply.
B Bottom (1)	13 ³ / ₄ x 58 ¹ / ₄ - ³ / ₄ ply.
C Sides (2)	13 ³ / ₄ x 36 - ³ / ₄ ply.
D Back (1)	35 ³ / ₄ x 58 ¹ / ₄ - ³ / ₄ ply.
E Top Shelf (1)	13 x 57 ¹ / ₂ - ³ / ₄ ply.
F Vertical Dividers (2)	13 x 23 ⁷ / ₁₆ - ³ / ₄ ply.
G Drawer Shelves (2)	13 x 20 ¹ / ₄ - ³ / ₄ ply.
H Drawer Dividers (2)	4 x 13 - ³ / ₄ ply.

Storage

I Drawer Fronts (4)	³ / ₄ x 37 ¹ / ₁₆ - 9 ⁷ / ₁₆
J Drawer Backs (4)	3 ⁷ / ₁₆ x 9 ⁷ / ₁₆ - ³ / ₄ ply.
K Drawer Sides (8)	3 ⁷ / ₁₆ x 12 ³ / ₄ - ³ / ₄ ply.
L Drawer Btms. (4)	8 ⁷ / ₁₆ x 12 ¹ / ₄ - ¹ / ₄ Mas.
M Panels (2)	18 ¹ / ₂ x 18 - ³ / ₄ ply.
N Hinge Plates (2)	3 ³ / ₄ x 18 - ³ / ₄ ply.
O Catch Blocks (2)	³ / ₈ x 1 ¹ / ₂ - 2
P Shelves (2)	7 ³ / ₄ x 19 ⁵ / ₈ - ³ / ₄ ply.
Q Tool Platforms (2)	13 x 15 ⁵ / ₈ - ³ / ₄ ply.
R Platform Cleats (2)	³ / ₄ x ³ / ₄ - 13 ¹ / ₄

Bench

S Bench Cores (2)	22 ¹ / ₂ x 57 - ³ / ₄ ply.
T Bench Skin (1)	22 ¹ / ₂ x 57 - ¹ / ₄ Mas.
U Edging, long (2)	³ / ₄ x 1 ³ / ₄ - 57
V Edging, short (2)	³ / ₄ x 1 ³ / ₄ - 24

Flip-Up Door

W Door (1)	10 ³ / ₈ x 57 - ³ / ₄ ply.
X Edging, long (2)	³ / ₄ x 1 ³ / ₄ - 57
Y Edging, short (2)	³ / ₄ x 1 ³ / ₄ 11 ⁷ / ₈
Z Support Block (2)	³ / ₄ x 1 - 3
AA Legs (2)	1 ¹ / ₂ x 1 ¹ / ₂ - 31 ¹ / ₄

Also needed:

- 12 board feet of ³/₄"-thick hardwood. This includes 48 lin. ft. of ¹/₄"-thick by ³/₄"-wide hardwood trim, and the cleat for attaching the case to the wall.
- (1) 48" x 96" sheet of ¹/₄" Masonite
- (1) Optional four foot shop light

Hardware

- (58) #8 x 2" Fh Woodscrews
- (6) #8 x 1¹/₄" Fh Woodscrews
- (1lb.) #4 Finish Nails
- (2 oz.) 1" x #18 Wire Brads
- (2) 1¹/₂" x 30" Piano Hinges
- (2) 1¹/₂" x 28" Piano Hinges
- (2) 1¹/₂" x 18" Piano Hinges
- (8) Shelf Rests
- (2) Mag. Catches w/Screws
- (2) Folding Leg Brackets
- (1) #10 x 1¹/₄" Rh Woodscrews
- (2) Draw Catches w/Screws
- (4) #6 x 1" Fh Woodscrews
- (6) #6 x ³/₈" Fh Woodscrews
- (2) ³/₈" x 1¹/₂" Lag Bolts
- (2) 1¹/₄" Wood Knobs w/Screws
- (2) Self-locking Lid Supports (one left and one right)
- Appropriate mounting hardware to attach work center to wall

FEATURE PROJECT

OVERALL DIMENSIONS:
 CLOSED: 69½"H x 58½"W x 15¾"D
 OPEN: 69½"H x 58½"W x 38"D

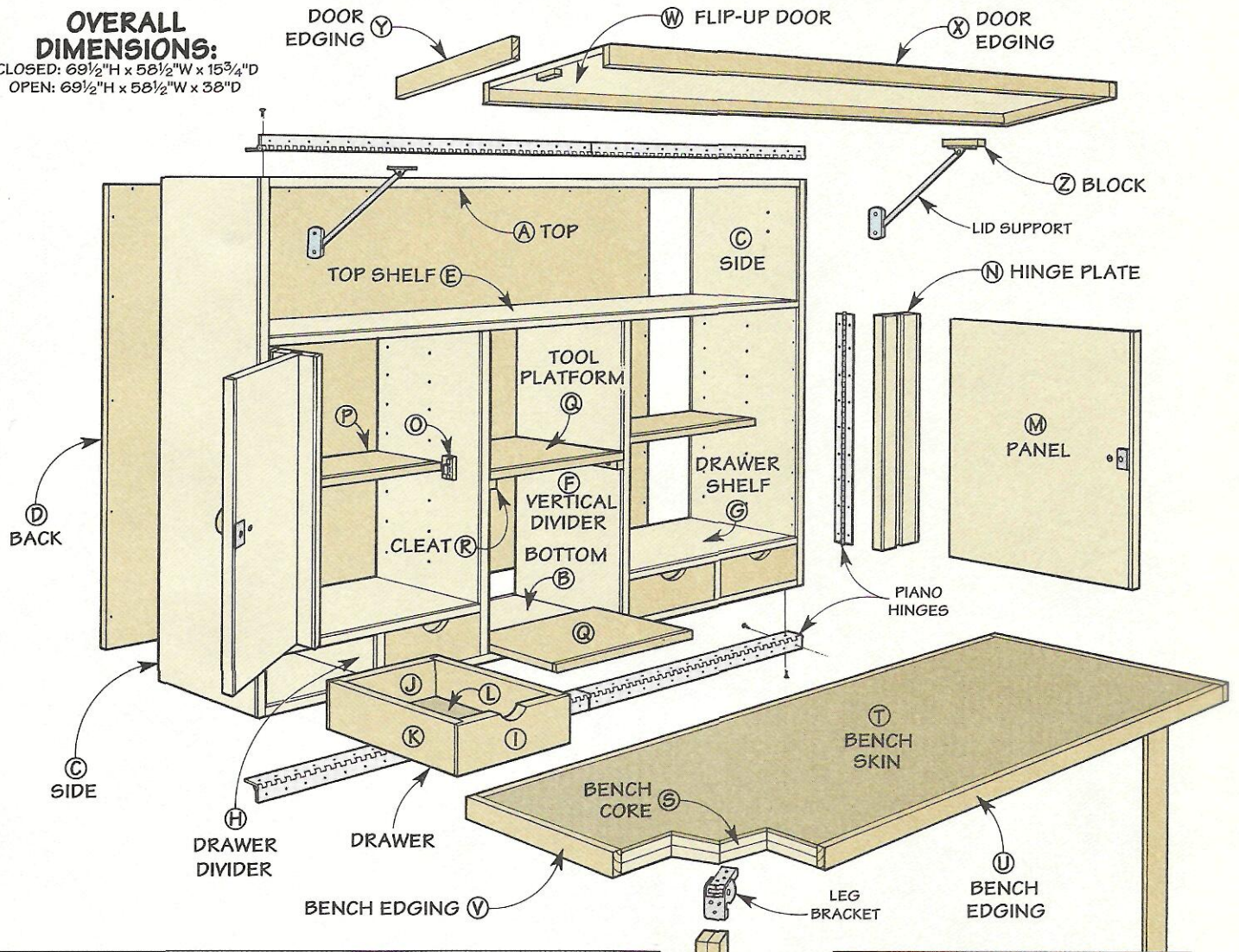

Plywood Cutting Diagram

48" x 96" - ¾" PLYWOOD 48" x 96" - ¾" PLYWOOD 48" x 96" - ¾" PLYWOOD

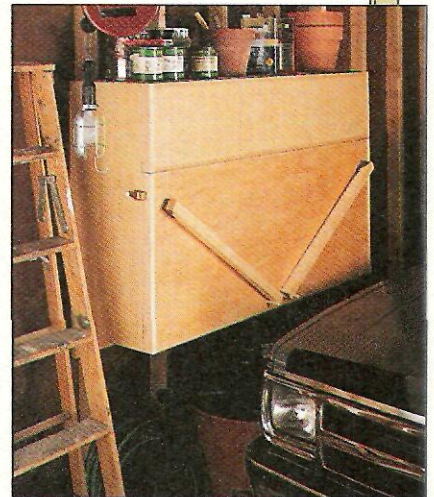
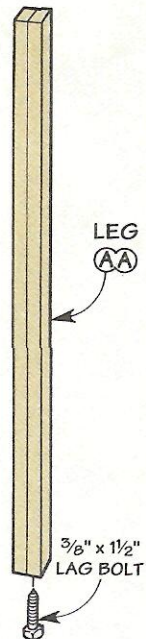
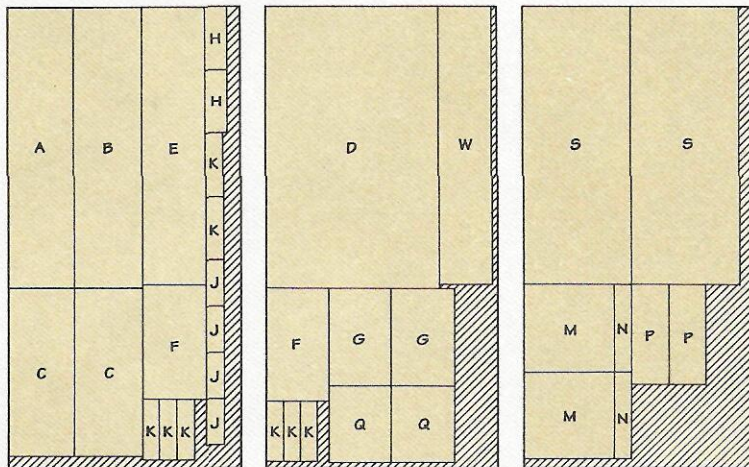

▲ Compact Design: This work center is designed to take up minimal space wherever it's used. The bench lifts up to lock in place, and the legs fold up like a card table.

The Case

The work center basically consists of a case, a fold-down bench, and a flip-up door. I started by building the case. It's just an open box with dividers, see Drawing.

CASE

To make the case, begin by cutting the pieces to make the open box, see Fig. 1. The top (A), bottom (B), and sides (C) are all cut from $\frac{3}{4}$ "-thick plywood (I used maple). The bottom (B) and sides (C) have dadoes cut in them to accept shelves and dividers that are added later, see margin Detail at left.

DADOES. To make it easy to slip the shelves and dividers into the basic box after it's assembled, it's best to cut these dadoes slightly wider than the thickness of your plywood. (In my case, they're $\frac{3}{4}$ " wide.)

RABBETS. Since I planned on screwing the top and bottom to the sides, the next step is to cut rabbets on both ends of the side pieces, see Fig. 1. These rabbets are cut extra deep ($\frac{5}{8}$ "), see Fig. 1a. This way, I could use long screws (for strength) and run them straight in.

But before you can assemble the case, there's one more thing to do. You'll need to cut $\frac{5}{8}$ "-deep rabbets on the back edges of all the case pieces (A, B, and C). These rabbets are for a plywood back that's added after the case is assembled, see Fig. 1b.

ASSEMBLY. Once all of the rabbets are cut, glue and screw the top and bottom to the sides, see Figs. 1 and 1a. Then cut a back (D) from $\frac{3}{4}$ " plywood to fit the case and glue and screw it in place.

SHELVES & DIVIDERS

With the basic box complete, you can start adding the shelves

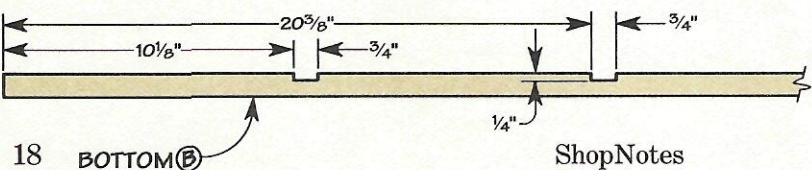
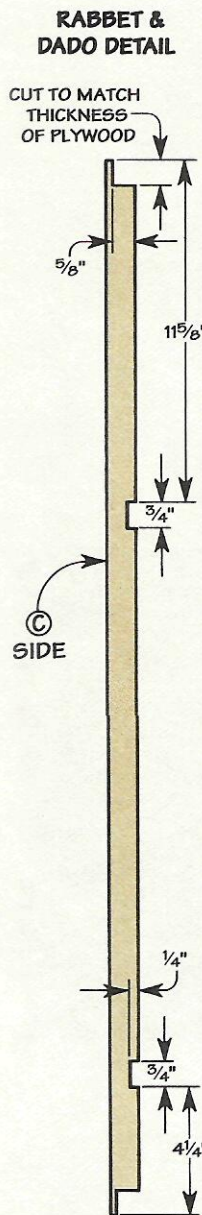
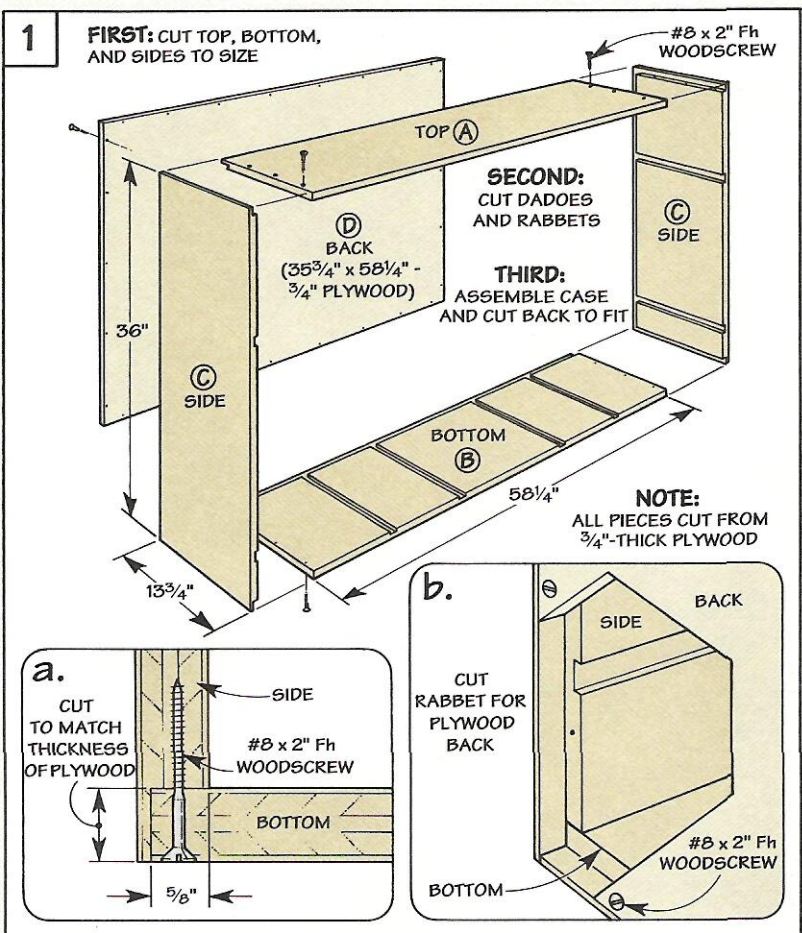
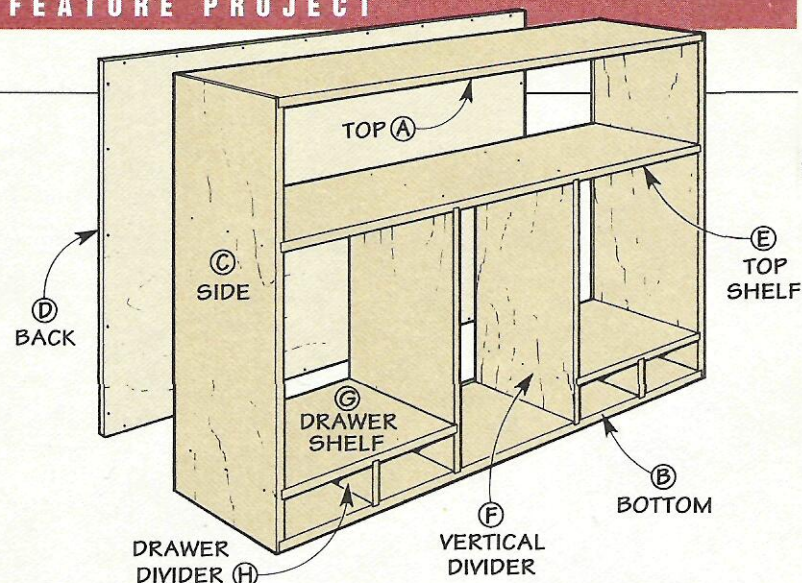

and dividers, see Figs. 2 and 3. Since most of these pieces will have dadoes cut in them to match those in the case, they need to be cut in order using a simple method

to locate the dadoes. The trick is to slip each piece into the case and mark the dado locations with it in place. Then the piece can be removed and the dadoes cut.

TOP SHELF. Start by cutting a top shelf (E) to fit between the upper dadoes in the sides, see Fig. 2. The next step is to cut

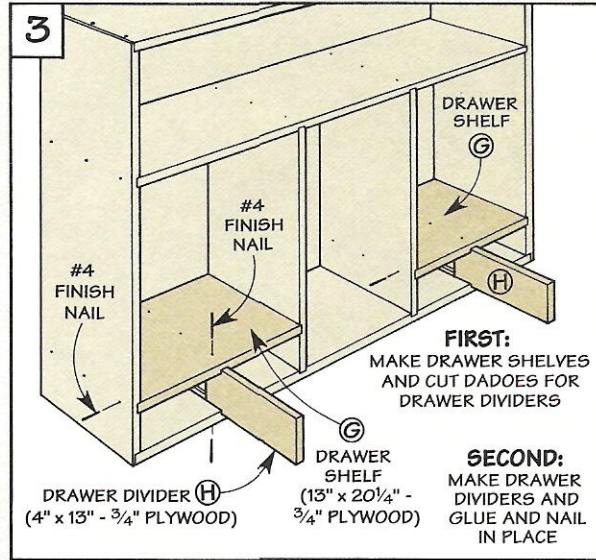
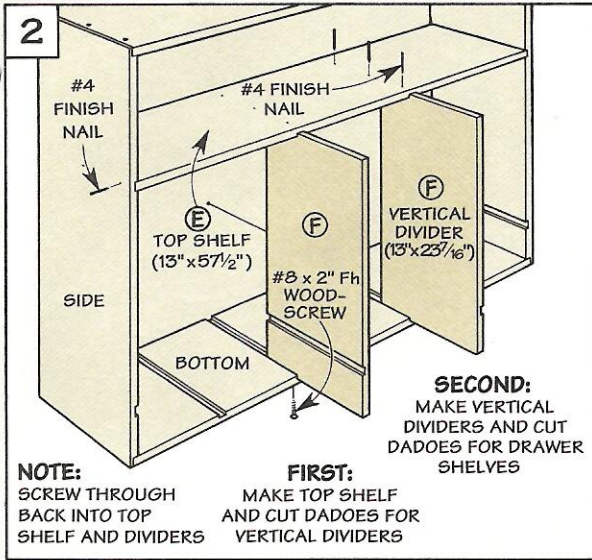

dadoes in this shelf for the vertical dividers that fit between the top shelf and the bottom, see Fig. 2. Since you've already cut the dadoes in the bottom (B), the tricky part is cutting a matching set in the top shelf.

STORY STICK. The easiest way I've found to do this is to use a story stick, see box below. This way, you don't have to measure anything. Instead, mark the stick and transfer the dado locations.

Once the dadoes have been cut in the top shelf, you can glue and nail it in place. Note: For extra strength, I screwed through the back (D) and into the edge of the top shelf (E).

VERTICAL DIVIDERS. Now you can cut a pair of vertical dividers (F) to fit between the top shelf (E) and bottom (B), see Fig. 2. Before you install them, use the story stick again to locate dadoes for the drawer shelves. Then, glue and screw the dividers to the back and bottom of the case. (I used nails to secure the top shelf.)

DRAWER SHELVES & DIVIDERS. With the vertical dividers installed, use the same procedure along with the story stick to cut two drawer shelves (G) first and then two drawer dividers (H). When they're cut to size, glue and nail them in place.

TRIM

All that's left to complete the case is to cover all of the exposed plywood edges on the front of the

case with trim (I used maple), see Fig. 4. The trim is 1/4"-thick and cut to match the thickness of the plywood. Then it's attached to the case with glue and brads.

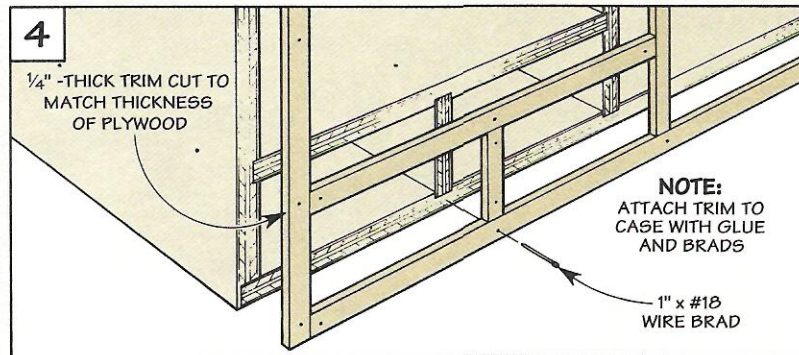

Transferring Dado Locations

FIRST:
MARK LOCATION OF DADO ON STICK

NOTE:
BUTT END OF STICK AGAINST INSIDE OF CASE

SECOND:
USE STICK TO TRANSFER DADO LOCATION TO WORKPIECE

Step 1: Mark Stick. To transfer dado locations, butt one end of a scrap wood stick against the inside of the case and mark the exact locations of the dadoes.

Step 2: Mark Workpiece. Then with the same end of the stick against the case, move the stick to where the dadoes need to be cut and transfer the marks.

Drawers

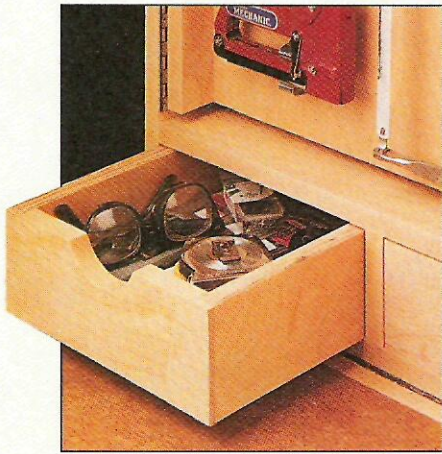

With the case complete, I began work on a set of pull-out drawers that fit in the openings near the bottom of the case, see photo.

Each drawer consists of a hardwood *front* (I), and a *back* (J) and two *sides* (K) cut from 3/4"-thick plywood. For clearance, each piece is cut 1/16" less than the height of the opening (3 7/16"). Likewise, the front and back are cut 1/16" narrower than the width of the opening (9 7/16", in my case).

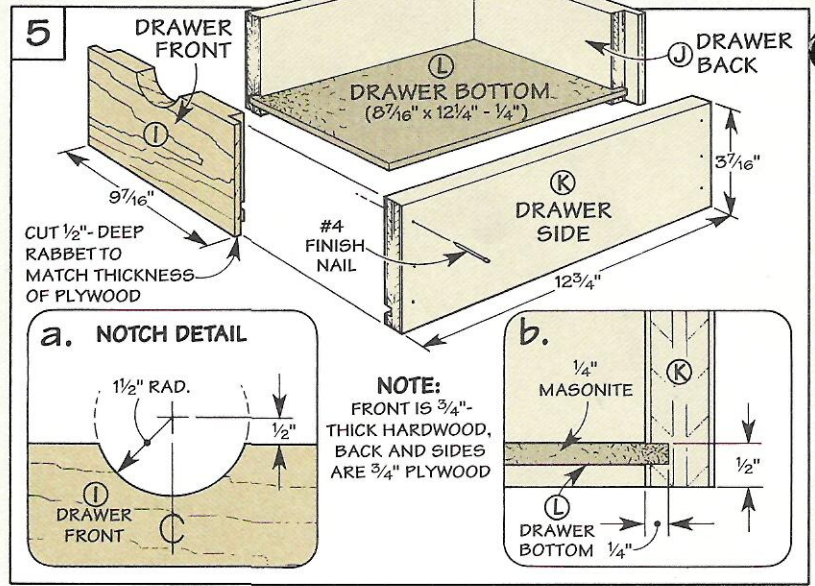

RABBETS. To join the drawers together, 1/2"-deep rabbets are cut in the ends of each front and back piece, see Fig. 5.

CUT NOTCH. Before you can assemble each drawer with glue and nails, there are two more things to do. First, to make the drawers easy to pull out, a cen-

tered notch is cut in each drawer front (I), see Fig. 5a.

ADD BOTTOM. Second, a 1/4" x 1/4" groove is cut near the bottom inside edge of each drawer piece, see Fig. 5b. This groove is for a *bottom* (L) made from 1/4"-thick Masonite that's cut to fit inside each of the drawers, see Fig. 5.

Tool Boards



To keep my tools handy, I mount them on T-shaped tool boards that swing out of the large openings on each side of the case, see photo above.

Each tool board consists of a panel for mounting the tools and

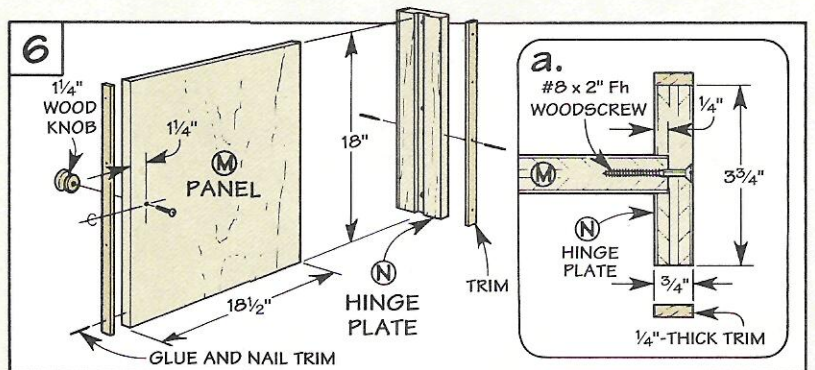

a hinge plate for attaching the panel to the case, see Fig. 6.

PANELS. Both *panels* (M) are cut from 3/4" plywood to a length (height) of 18". As for the width, measure the width of your opening and subtract 1 1/4" for clearance. (In my case, it's 18 1/2" wide.)

HINGE PLATES. The plywood *hinge plate* (N) is 3 3/4" wide and

cut to match the height of the panel (18"). Then a 1/4"-deep groove is cut centered on the plate to accept the panel, see Fig. 6a.

ASSEMBLY. Once the grooves are cut, glue and screw one hinge plate to each panel. Then cover the exposed plywood edges by gluing and nailing on 1/4"-thick trim, see Fig. 6.

MOUNT BOARDS. I used an 18" length of piano hinge to attach each tool board to the case, see Fig. 7. To do this, center a hinge in between the top shelf and the drawer shelf with the knuckle flush with the front of the case,

see Fig. 7a. Then screw it in place.

Next, for each tool board to swing open completely, insert a temporary 1/8" spacer between the board and case before screwing the hinge in place, see Fig. 7a.

Finally, to pull open the boards,

a wood knob is screwed to the front of each board, see Fig. 6. And to keep the boards closed, I used a magnetic catch, see Fig. 8. Note: Each catch is screwed to a catch block (O) that's glued to the case, see Fig. 8a.

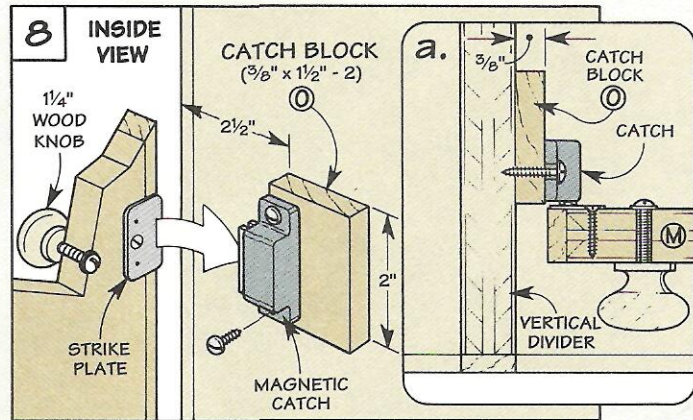
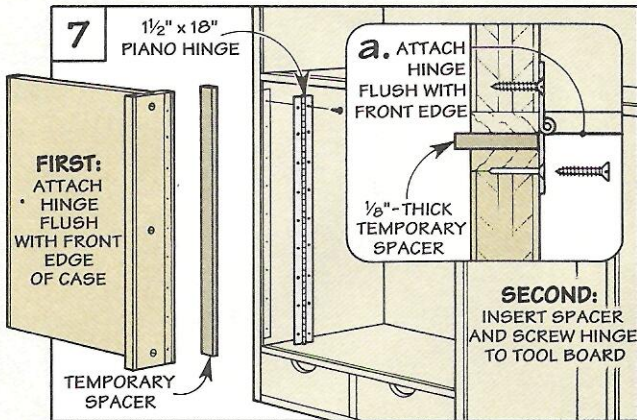

Shelves

For additional storage, I added an adjustable shelf behind each tool board, see photo.

SHELF. Each plywood shelf (P) is 7 3/4" wide (deep) and cut to fit between the sides and vertical dividers, less an 1/8" for clearance (19 5/8"), see Fig. 9. Once they're cut to size, the front edge is covered with 1/4"-thick trim.

SHELF RESTS. The shelves sit on metal shelf rests that fit into holes in the case. To drill the holes so they're evenly spaced, I made a template, see Fig. 10.

The template is just a scrap of

3/4"-thick plywood with a series of 1/4" holes. To use it, just press it against the case (or vertical divider) and with the aid of a depth stop, drill the holes. Note: Make sure to always butt the same edge against the back (D).

TOOL PLATFORMS. Finally, to make it easy to clamp a vise or grinder to the bench, I mount them on tool platforms (Q) that fit in the center opening of the case, see photo.

The lower tool platform is designed to rest in the bottom of the case. But the upper tool platform

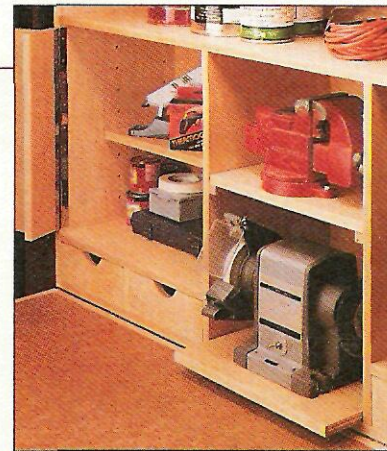

sits on a pair of 3/4"-square tool platform cleats (R) that are screwed to the vertical dividers, see Figs. 9 and 9a.

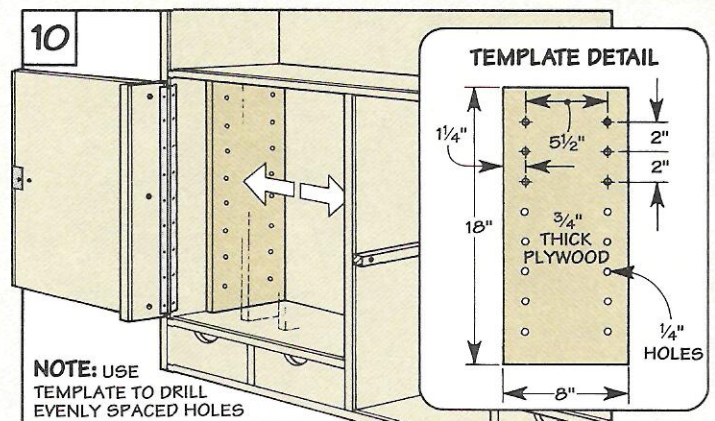
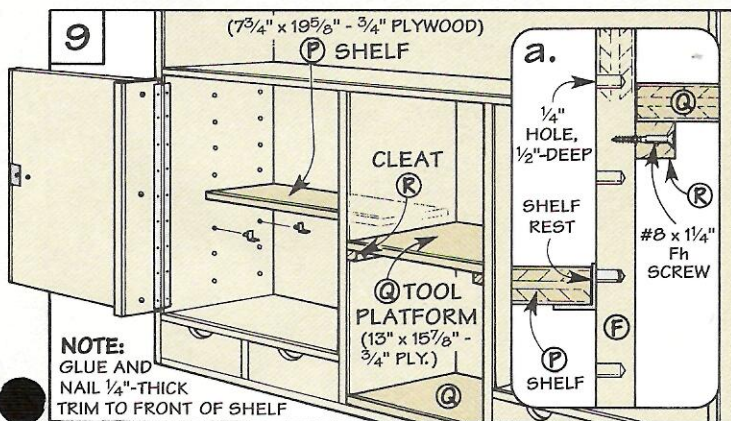

Case Front

After completing work on the inside of the case, work can begin on the case front. The front consists of a fold-down bench and a flip-up door, see Fig. 11. I started by making the bench.

BENCH. To create a bench top that's solid and durable, I glued up a three layer slab. Two pieces of $\frac{3}{4}$ " plywood form a solid core (S). And a $\frac{1}{4}$ "-thick Masonite skin (T) provides a durable work surface, see Figs. 11 and 11b. The width of the slab is $22\frac{1}{2}$ ".

But its length is $1\frac{1}{2}$ " less than the overall width of the case, see Fig. 11. This allows for $\frac{3}{4}$ "-thick edging (U,V) to be glued to the slab, see Figs. 11 and 11a.

DOOR. Once the bench is complete, the next step is to add the door. It covers the storage area at the top of the case. And it flips up to provide a handy place to mount a shop light, see photo below.

The door (W) is just a single piece of $\frac{3}{4}$ "-thick plywood, see Fig. 11. And just like the bench, it's wrapped with hardwood edging (X,Y), see Fig. 11b.

ASSEMBLY. With the bench and door complete, they can now be attached to the case. To provide as much support as possible, I used piano hinges. The easiest way to mount these hinges is to lay the case down on its back and clamp the bench and door in place, see Figs. 12 and 12a.

While I was at it, I installed two draw catches to hold the bench tight against the case, see Fig. 12a. Then to hold the door open, I used a pair of special self-locking lid supports, see Fig. 13. One end is screwed inside the case. The other screws into a support block (Z) glued to the door, see Fig. 13a.

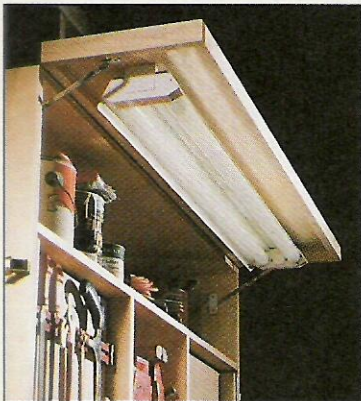

▲ **Optional Light.** The flip-up door is sized to accept a standard four foot shop light.

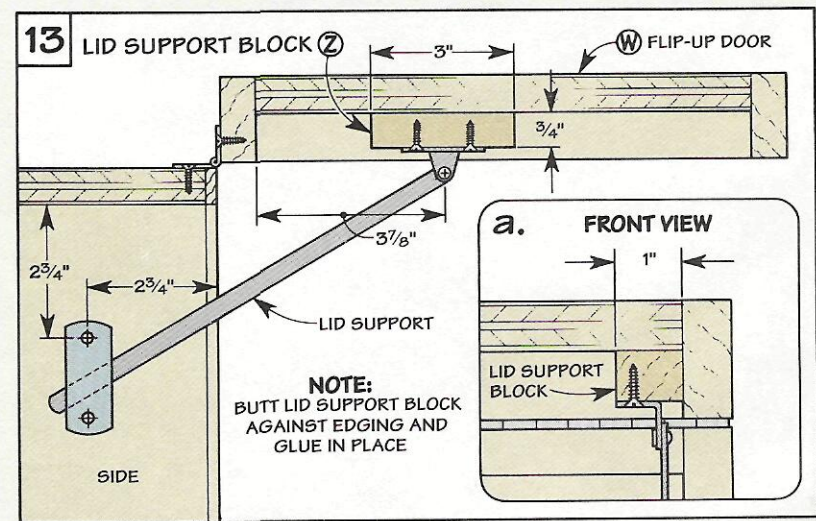
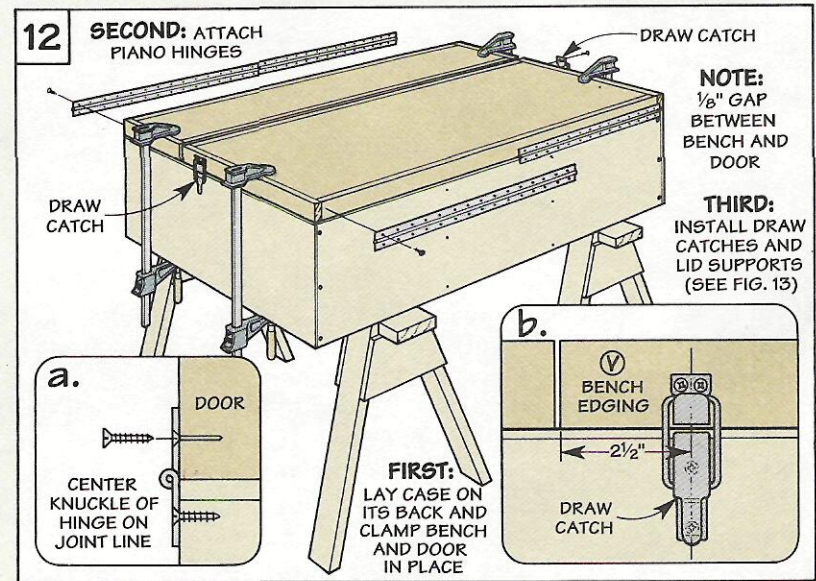
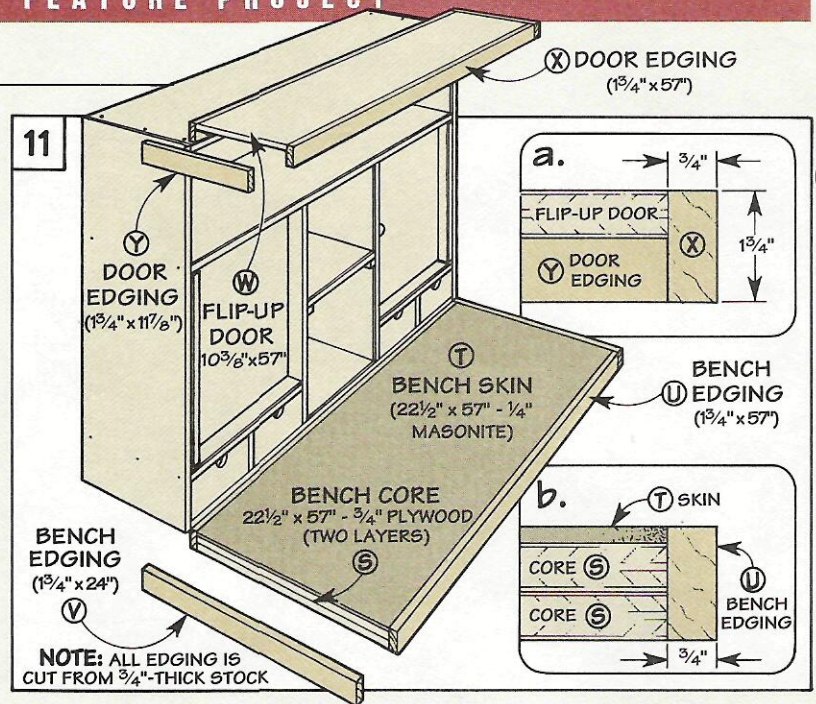

The Legs

To support the bench in the open position, I added a pair of folding legs, see Fig. 14. The *legs (AA)* are glued up from two pieces of 3/4"-thick stock, see Fig. 14. Then I screwed lag bolts in the bottom of each leg to act as levelers on uneven floors, see Fig. 14b.

MOUNT LEGS. With the levelers in place, the next step is to mount the legs. The legs attach to the bench with heavy-duty folding brackets that work similar to those found on a card table, see margin photo. (For more information, see sources on page 31.)

To attach the brackets, first screw one to each leg, see Fig. 14a. Then position the legs and screw them in place, see Fig. 14b. Finally, I added a pair of stops to support the legs when they're folded up, see Figs. 14 and 14b.

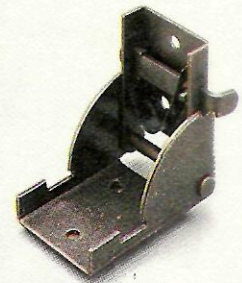
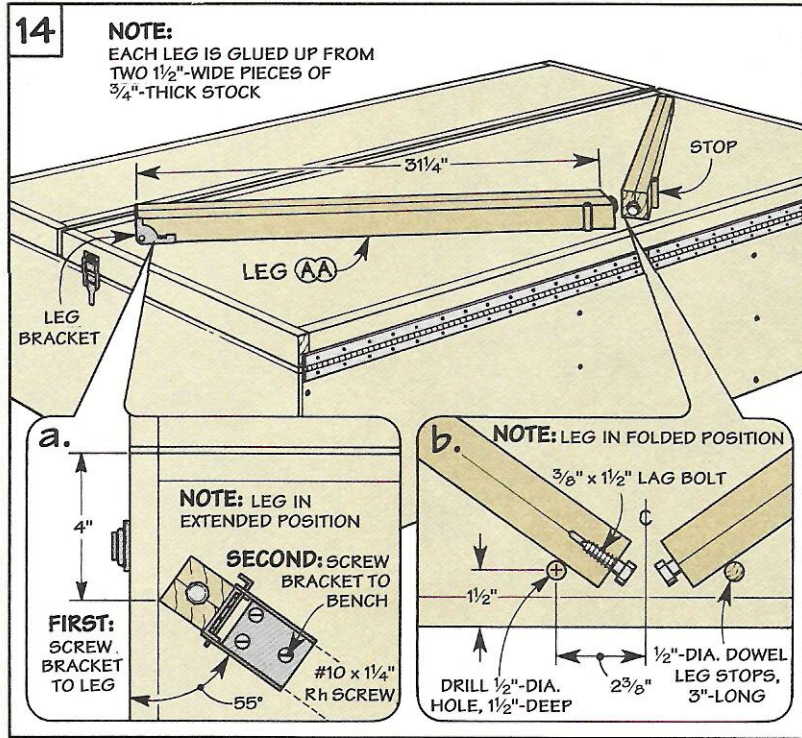

▲ This heavy-duty folding leg bracket locks securely in either the open or closed position.

Mounting the Work Center

Now that the work center is complete, it can be mounted to a wall. To support the case while attaching it to the wall, I used a cleat. This cleat also allows you to accurately position the height of the work center and keep it level.

WALL CLEAT. The cleat is just a piece of 3/4"-thick hardwood cut to match the width of the case (58 1/2"), see Fig. 15. Then bolt it to the wall so it's level and the top edge is 33 1/2" from the floor, see Figs. 15 and 15a.

Note: If you're mounting the cleat to a wood framed wall, make sure that you screw into the wall studs. Then, with the help of a friend, lift up the case and set it on the cleat.

Finally, to attach the case to the wall, lower the bench and lift up the door. Now it's just a matter of drilling holes in the case, and installing lag bolts and washers. (Here again, make sure you hit the wall studs.)

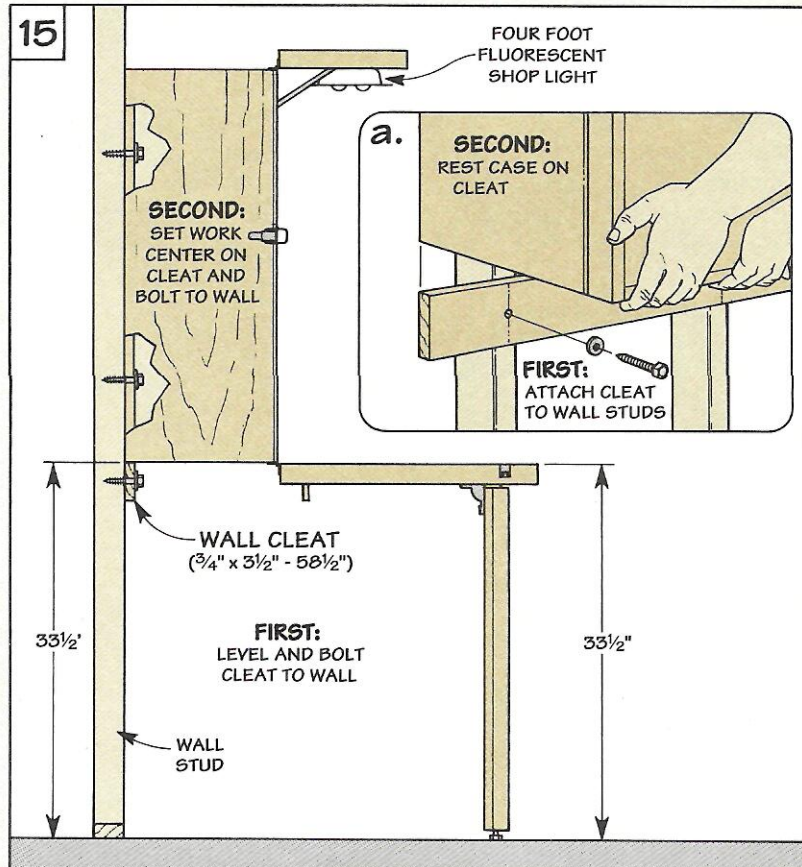

Drill Press Tips

Quick and simple solutions to the everyday problems you can encounter when boring holes with a drill press.

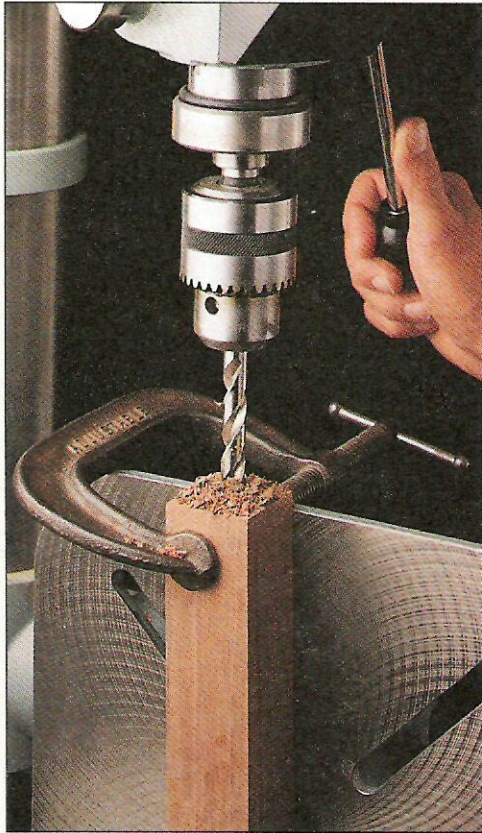

Drilling a hole in a workpiece is simple. It's not until you're faced with an odd-shaped workpiece, or drilling multiple holes that it becomes difficult.

Whenever these situations arise, you're usually faced with two different challenges. First, there's the problem of positioning and aligning the workpiece. Then

you have to figure out a way to hold or clamp the workpiece in place for drilling.

Over the years, we've encountered these same problems in the shop. And the solutions to most are simple — usually just a scrap-wood jig. The next four pages describe our solutions to the most common shop drilling problems.

Table and Fence

One of the simplest ways you can improve the performance of your drill press is to add an auxiliary table and a fence, see Fig. 1.

TABLE. Clamping or screwing a wood table to your drill press protects the metal table (and your bits) as you drill through a workpiece. It also backs up the hole and reduces

splintering and chip out.

FENCE. Attaching a fence to the table allows you to quickly and accurately position a workpiece. This is particularly useful whenever you need to drill similar holes in multiple workpieces.

TWO STYLES. I use two different styles of auxiliary table in my

shop. One is large to provide extra support to a workpiece and is screwed (or clamped) to the table, see Fig. 1.

The other style is smaller and features a built-in fence, see Fig. 2. To use it, just place it at the desired location, and then use spring clamps to hold it in place.

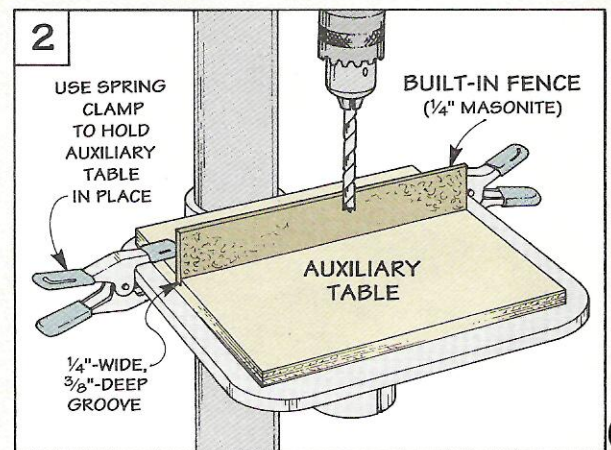
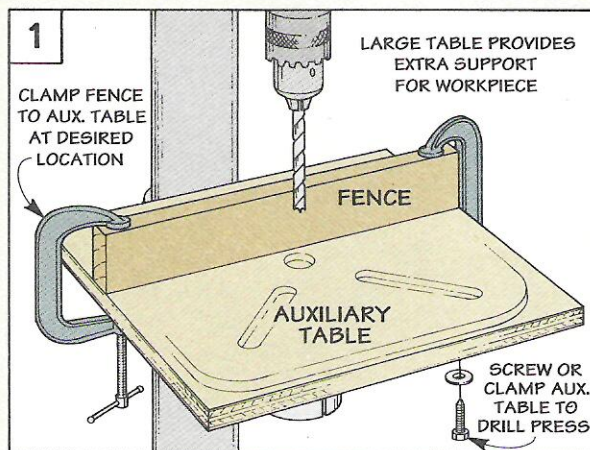

Drilling Deep Holes

Index Pin

Drilling a hole in a workpiece can be tricky when the hole is deeper than the length of the bit. One simple solution is to drill from opposite ends of the workpiece.

But then you're faced with aligning the two holes. To solve this, I use an index pin, see Figs. 1 and 2. This method guarantees that the holes will line up.

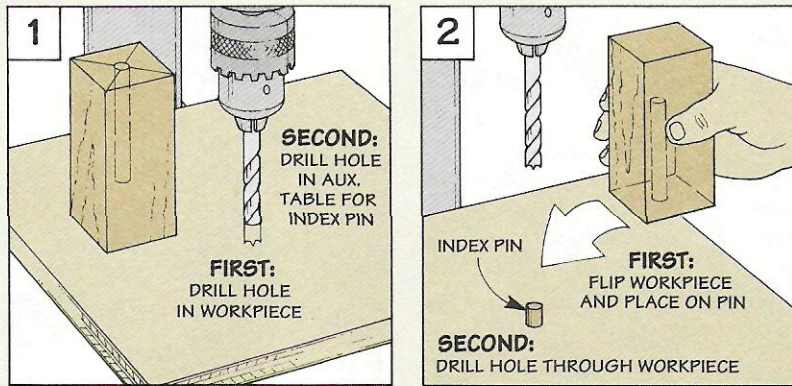

Riser Block

A different problem occurs when the bit is long enough to drill the hole, but the spindle travel of the quill limits the depth you can drill.

You could drill as far as possible, then raise the table. But then the workpiece has shifted. My solution is simple. Instead of raising the table, lift the workpiece with a riser block, see Figs. 1 and 2.

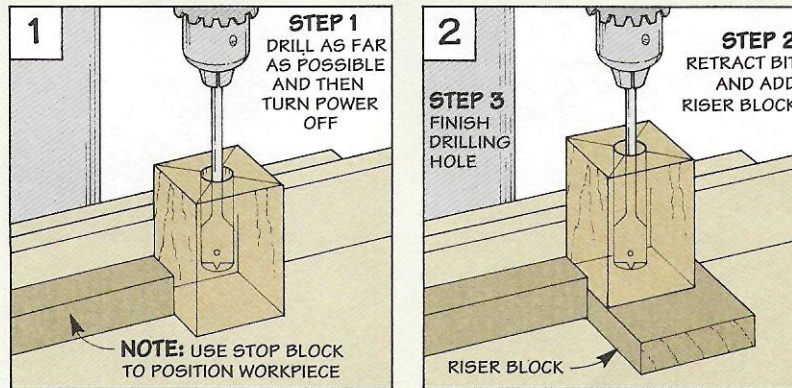

Drilling Holes in Dowels

Alignment Jig

Centering a hole in the end of a short dowel is a challenge. But holding it in place to drill the hole can be even trickier.

To solve both problems, I use an alignment jig, see Fig. 1. It automatically centers the bit in the dowel end. And with the help of a handscrew, it makes it easy to hold the dowel, see Fig. 2.

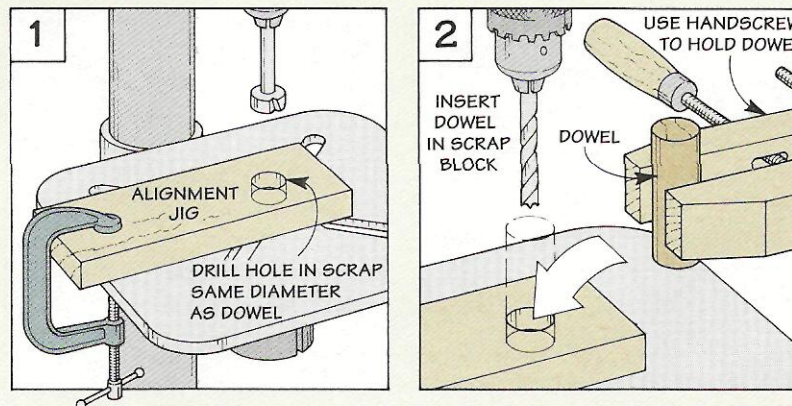

V-Block

It takes a different jig to center a hole in the side of a dowel and keep it from rolling around. Here, I use a V-block, see Drawing.

To center a bit on the block, I insert a pointed rod in the chuck and align the point with the bottom of the V-block, see Detail. Then just clamp the V-block to the table and drill the hole.

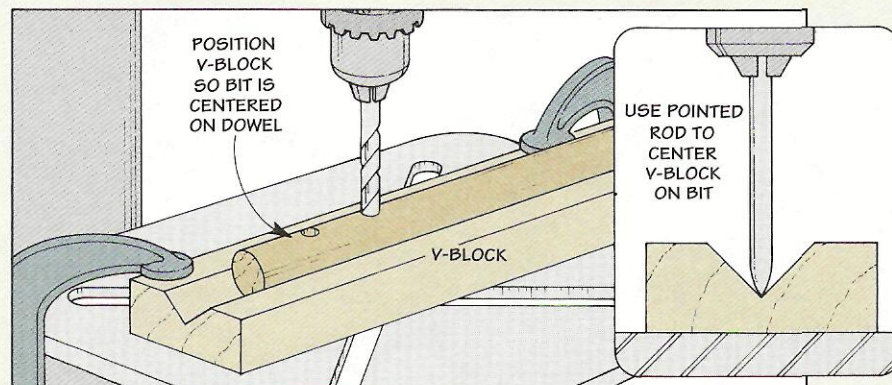

Drilling in Long Objects

Vertical Drilling

Occasionally, you may need to drill into the end of a workpiece that's too long to sit on the table. One solution is to tilt the table of your drill press to 90° and clamp the workpiece to it, see Fig. 1.

If your table doesn't tilt, you can build a right-angle jig, see Fig. 2. Then secure the jig and clamp the workpiece to it.

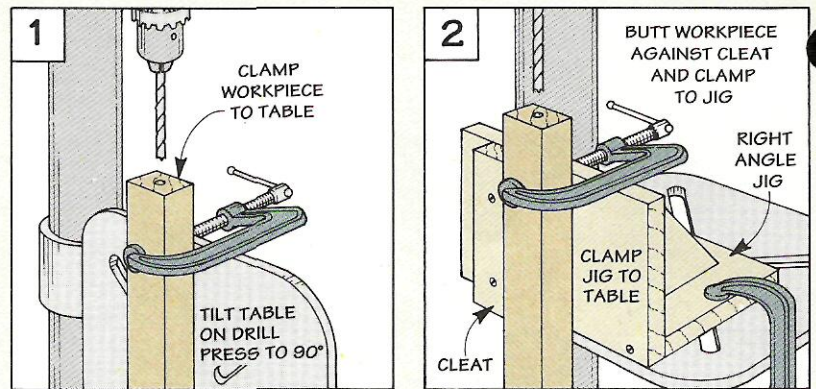

Handscrew

Another way to position a long workpiece for drilling is to use a handscrew, see Drawing.

A small guide strip screwed to the top of the handscrew helps square up the workpiece, see Detail. And at the same time it allows you to drill holes of the same depth in multiple workpieces (such as the legs of a table).

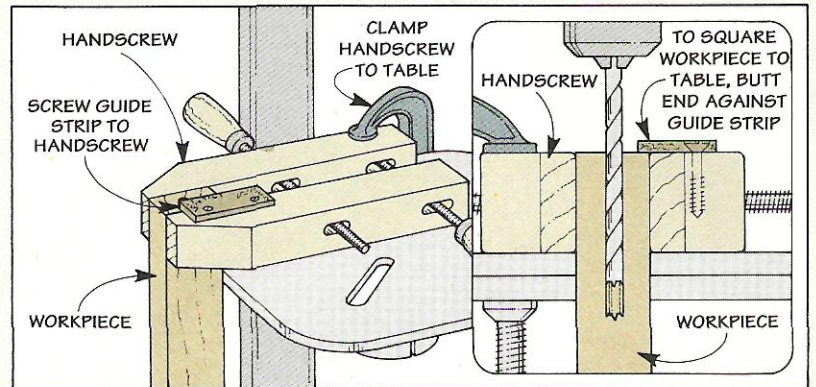

Enlarging Holes

How many times have you drilled a hole only to discover that you needed a larger one? Or needed to drill a counterbore *after* the pilot hole was already drilled?

The problem with either situation is the drill bit will drift off center or wobble because there's nothing to support the point of the bit as it enters the hole.

Plugging the hole with a dowel will give you the support you need. But how do you make sure that the bit is centered exactly to drill the second hole?

The answer is to use the same method. To do this, start by chucking a bit the same size as the first hole in the drill. Then with the power off, lower this bit into the

hole, see Fig. 1. Now clamp the workpiece to the table and retract the bit from the hole.

Next, replace the first bit with the one for the larger hole, see Fig. 2. (Note: To support the point of spade bit, insert a tight-fitting dowel in the first hole, see Fig. 2.) Then just drill the hole — it won't drift off center or wobble.

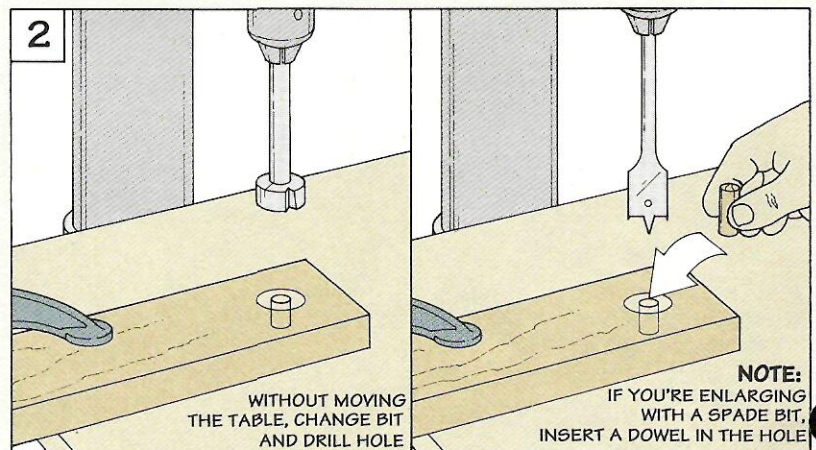
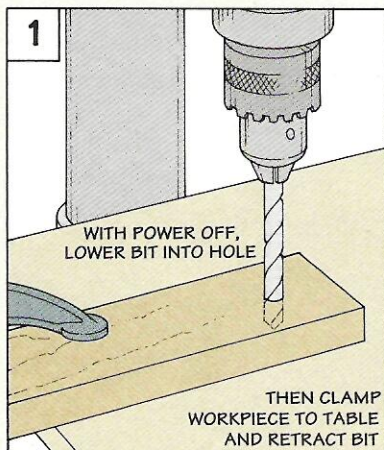

Drilling Evenly Spaced Holes

Indexing Jig

Whenever I'm faced with drilling a series of evenly spaced holes (such as shelf supports), I use a simple indexing jig, see Drawing.

It's just a scrap fence with a set of holes drilled to match those of the project. An index pin (a dowel) fits in the holes to position the workpiece at even increments.

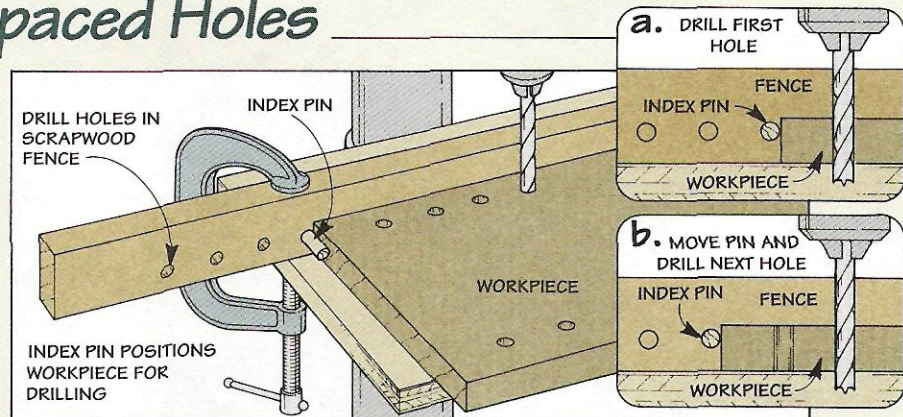

Corner Jig

A lot of projects I build require holes in all four corners of a workpiece (such as pilot holes for assembly or hardware).

You could spend the time to lay them all out. Or you can build a jig that automatically positions the workpiece to drill an identical hole in each corner, see Drawing.

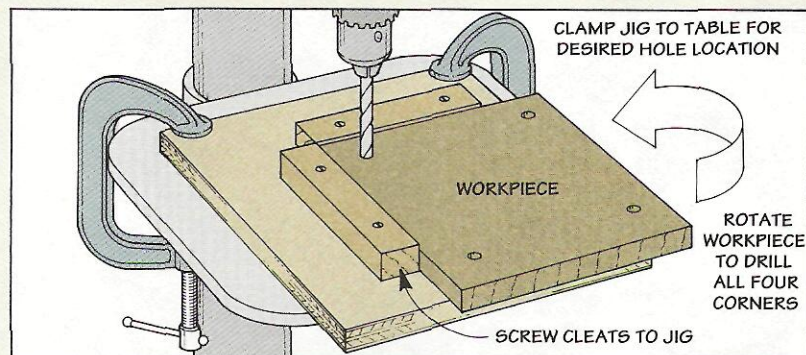

Contour Jig

Unusual Shapes

Whenever I need to drill accurate holes in odd-shaped pieces, I make a jig to hold the workpiece securely in position on the drill press table, see Drawing.

Just trace the contour of the workpiece on the jig and cut it out. A shoulder on the end keeps the workpiece from sliding.

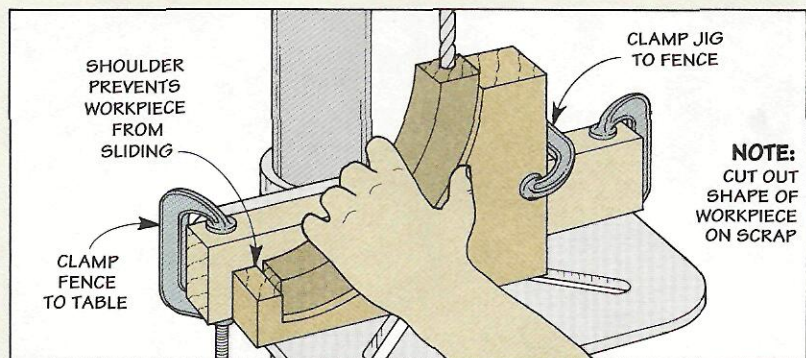

What speed should I drill?

In addition to the tips in this article, one of the best ways to get the most out of your drill press is to select the correct speed for the bit and material you're using.

As a general rule of thumb, I use the *slowest* speed available. This is especially true when using large bits and whenever you're drilling into hardwood.

- **Forstner Bits:** These bits were never designed to be run in a drill press. Run them below 400 RPM or they'll overheat and burn.
- **Spade Bits:** Since these bits scrape and don't cut, they create friction. Run below 500 RPM to reduce heat and keep them sharp.
- **Brad Point Bits:** The best policy for these bits is to ignore speed charts on drill presses. For best results, I use 500 to 1000 RPM.
- **Twist Bits:** Designed to drill into metal, these bits can take the heat. I usually run twist bits between 1000 to 2000 RPM.

Shop Solutions

Pipe Clamp Caddy

■ I used to store my pipe clamps on the wall. But I got tired of trying to juggle an armful of clamps every time I glued up a project. To avoid this, I made a pipe clamp caddy that can be rolled around to wherever I'm



gluing up a project, see photo. And it serves to store and organize my clamps as well.

The clamp caddy consists of a plywood box with "sleeves" (1 1/4"-dia. PVC pipe) to hold the clamps upright, see Drawing. To keep the sleeves vertical, I added a plywood support panel in the middle of the box.

Since the holes in the support panel and the top must align perfectly,

I carpet taped two of the panels together before laying out and drilling the holes.

Once all the wood parts are glued and screwed together, four heavy-duty swivel casters are screwed to the bottom, near the corners. Finally, cut the PVC sleeves to length and slide them in place.

*Richard J. Gotz
Plymouth, Minnesota*

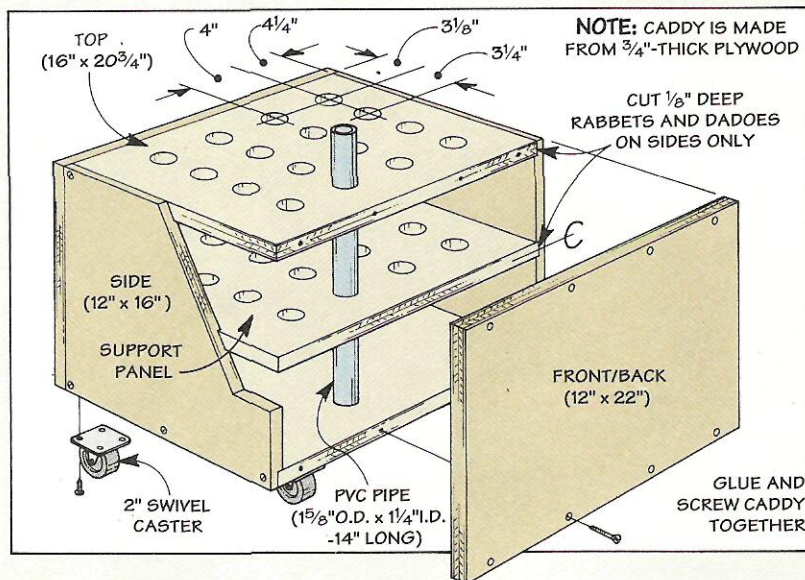

Foot Pedal Modification

■ I modified the foot pedal in *ShopNotes* No. 12 to solve two other problems I had with my drill press. First, it doesn't have a depth stop. And second, the quill doesn't lock in place.

By cutting a slot down both side pieces, you can insert a carriage bolt either above or below the pedal, see Drawing. When it's above the pedal, the bolt serves as a quill lock. To control the depth, place the bolt below the pedal.

*Jeffery D. Everling
Sylvan Lake, Michigan*

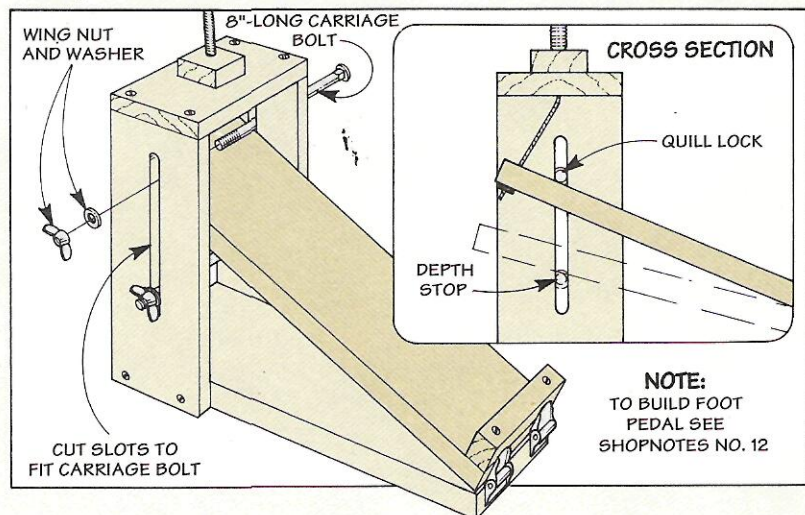

Bench-Top Belt Sander

Occasionally I need a bench-top belt sander. But rather than buy one, I made a simple jig that allows me to clamp my hand-held belt sander upside down in my bench vise.

The jig is just a short length of 2x6 with two holes for hose clamps, see photo. To use the jig, first clamp the 2x6 to the handle of the belt sander with the hose clamps. Then clamp the sander upside down in the bench vise.

To use the sander, lock the power switch in the "on" position. This frees up both of my hands so I can safely hold the workpiece against the spinning belt.

Wayne Beedy

Buckley, Washington

Editor's Note: Not all belt sanders have a flat handle. So it may be necessary for you to file or bandsaw one edge of the 2x6 to match the shape of the handle on your sander.

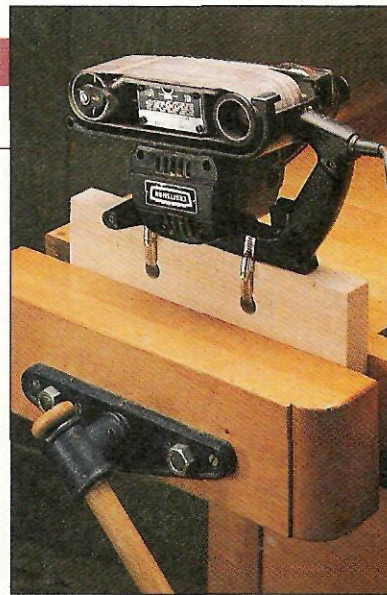

Chisel Block

I like to have my chisels within easy reach. To do this, I store them on my workbench in a shop-made chisel block that's similar to those used to store knives in the kitchen.

The chisel block consists of seven pieces of $\frac{3}{4}$ "-thick stock, see Drawing. Three pieces have grooves cut in them that form individual pockets for each chisel. And to make it easy to pull a chisel from a pocket, I cut one end of each piece at 80° so the block is angled at the top.

Before gluing up the chisel block, I added a small block of wood in the bottom of each groove. This prevents the chisel from gouging the workbench as it's dropped back in the slot.

Also, as your chisel collection

grows, you can easily add on to the block to extend its size.

Charles Gray
Lyons, Colorado

Editor's Note: When gluing-up

the block, it's a good idea to only glue up two pieces at a time. If you glue up more than two, they could slide around as you apply clamping pressure.

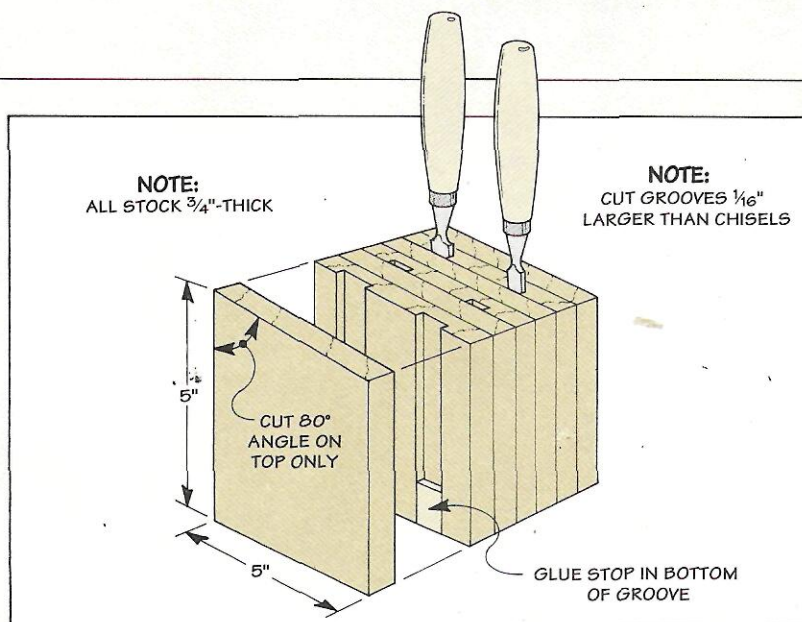

Mixing Resin Glue

When mixing up powdered resin glue, I always end up with a batch that's either too runny or too lumpy. The problem is, it's difficult to gauge exactly how much water to mix in with the powder.

I've tried mixing in a little water at a time. But when I add the water, it lumps up — even when it's poured in gradually.

The solution is to quit pouring

water into the powder altogether. The trick to getting a creamy consistency is to mist the water into the powder. To do this, I use a spray bottle (like the type used to mist plants).

The misting eliminates the large water droplets that seem to cause the clumping.

Merritt Brown Jr.
Panama City, Florida

Send in Your Solutions

If you'd like to share your original solutions to problems you've faced, send them to: *ShopNotes*, Attn: Shop Solutions, 2200 Grand Avenue, Des Moines, IA 50312. (Or if it's easier, FAX them to us at: 515-282-6741.)

We'll pay up to \$200 depending on the published length. Please include a daytime phone number so we can call you if we have questions.

Gel Stains

■ *I'm considering using a gel stain on a project I'm working on. How do they compare with the liquid stains I've used in the past?*

*Mark Osterberg
Red Wing, Minnesota*

Like their name implies, gel stains have a much *thicker* consistency than liquid stains. Because of this, a gel stain doesn't run all over the workpiece and the floor — even when you apply it to a vertical surface like a chair leg, see photo above.

The thickness of a gel stain depends on the brand you use. Some have the consistency of a milk shake and are squeezed out of a bottle, while others are more like a thick malt.

NO STIR. One other nice thing about gel stains is you don't have to keep stirring them as you work. Because they're thicker, the color pigment stays suspended instead of settling out in the bottom of the can. This means you get a consistent color from the top to the bottom of the can.

REDUCES BLOTCHING. But the real test of a stain is whether or not it creates a nice, even color when it's applied to the workpiece. Unlike the light and dark

blotches you sometimes get with liquid stains, gel stains produce a much more uniform color.

The reason is simple. There's less solvent in a gel stain. (Both oil and water-based gel stains are available). Because this solvent is what carries the color into the wood, the stain doesn't penetrate as deeply. As a result, you don't get as many splotches — especially on end grain.

APPLICATION. There's nothing complicated about applying a gel stain. The best way I've found is

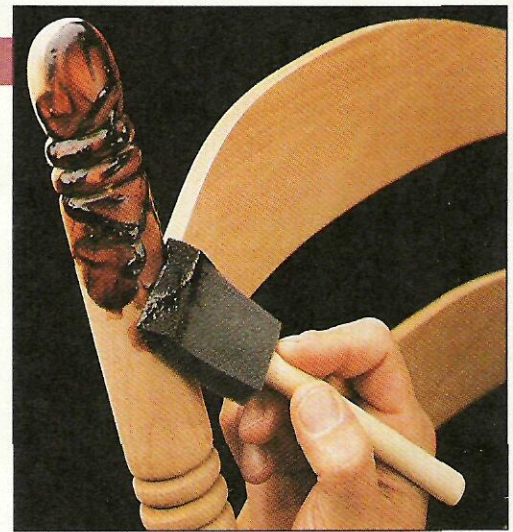

brush over it, you'll get lap marks where the wet stain covers a section that's already dry.

WIPE OFF. So once the surface is covered, I use a clean rag to wipe off as much of the excess stain as possible, see photo below right. To prevent streaking, the idea is to wipe in the direction of

the grain until the workpiece is almost "dry." Note: When working on flat areas, you may want to save some of the stain before wiping it off, see margin tip at left.

WET EDGE. To prevent lap marks when working on large areas, I divide it into smaller sections and keep a "wet edge" between each section. Unfortunately, this doesn't always work.

In this case, you can remove some of the stain with a cloth dampened in mineral spirits (or water if it's a water-based stain). Then apply more stain as you work both sections together.

A thick consistency not only keeps gel stains from running. It results in a more even color as well.



To recycle stain, scrape off the excess with a squeegee.

to use a foam brush, see photo below left. Don't be dainty here. Just load up the brush (or squeeze the stain onto the wood). As you brush the stain around, the gel flows across the workpiece.

Just because the gel doesn't soak into the wood as much, don't be fooled into thinking you have a lot of time to work the stain. Like liquid stains, if you leave it on too long in one place and then

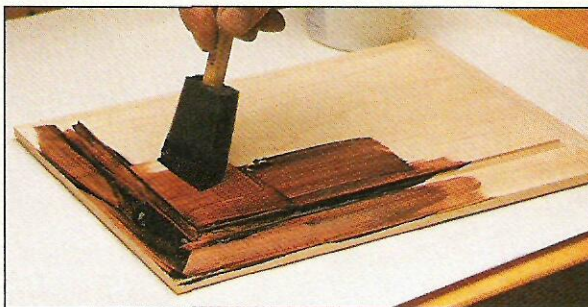

▲ *When you spread a gel stain around with a foam brush, it flows across the workpiece. Stop brushing, and it changes back to its gel consistency.*



▲ *After covering the surface of the workpiece, wipe off the excess stain with a rag. To avoid streaks, wipe in the direction of the grain.*

Sources

ShopNotes Project Supplies is offering some of the hardware and supplies needed for the projects in this issue. We've also put together a list of other mail order sources that have the same or similar hardware and supplies.

MITER GAUGE FENCE

The Miter Gauge Fence (shown on page 4) helps to increase accuracy whenever you crosscut on the table saw. An adjustable stop block slides in a T-slot in the fence and quickly locks into position. The built-in indicator and measuring tape allow you to accurately set up and make repeat cuts.

ShopNotes Project Supplies is offering a hardware kit for the Miter Gauge Fence. The kit has all the hardware you'll need, including the measuring tape and indicator. All you need to supply is 1/2" and 5/8"-thick hardwood.

S14-6814-100 Miter Gauge Fence Kit.....\$17.95

CHISEL PLANE

A chisel plane is the perfect tool to clean up those hard to reach places (like the corners of a cabinet, drawer, or door). Our shop-made version shown on page 8

features an extra-thick Hock blade that extends out in front of the plane body.

ShopNotes Project Supplies is offering a hardware kit for the Chisel Plane. It includes all the hardware you'll need including the Hock blade. All you need to supply is 1 1/2"-thick hardwood.

(Note: You can also order the Hock blade from the sources below. But be aware that these blades come with a cap iron that isn't used for the chisel plane.)

S14-6814-200 Chisel Plane Hardware Kit.....\$27.95

FOLD-DOWN WORK CENTER

Compact storage. And a large, solid work surface. Those were the two things I had in mind when I designed the Fold-Down Work Center shown on page 16.

To take up minimal space, the work center is mounted to a wall. Then I added tool boards, drawers, and shelves to provide plenty of built-in storage.

But best of all, the front of the case folds down to create a stable work surface that's large enough to handle almost any job.

LEG BRACKETS. To make this work surface as sturdy as possi-

ble, it rests on a pair of legs that fold up and down on special leg brackets. These heavy-duty metal brackets are designed to lock in either the open or closed position.

LID SUPPORTS. Above the work surface, there's a flip-up door for an optional shop light. It's held in place with special lid supports that lock automatically when you lift up the door.

ShopNotes Project Supplies is offering a complete hardware kit for the Fold-Down Work Center. (The shop light is *not* included.)

All you need to supply is 3/4"-thick plywood, 1/4" Masonite, and 3/4"-thick hardwood. Note: You'll also need mounting hardware to attach the work center to a wall.

S14-6814-300 Work Center Hardware Kit \$46.95

ANTI-KICKBACK BITS

The article on anti-kickback router bits (shown on page 6) describes how these new bits work. And it provides a look at the various bits currently available.

You may find these bits at woodworking stores and home building centers. If you can't find them locally, see the mail order sources listed below.

MAIL ORDER SOURCES

Similar hardware and supplies may be found in the following catalogs. Please call each company for a catalog or for ordering information.

CMT Tools
800-531-5559
Anti-kickback Router Bits

Constantine's
800-223-8087
Folding Leg Brackets

Japan Woodworker
800-537-7820
Hock Plane Blades

Leichtung
800-321-6840
Anti-kickback Router Bits

Trendlines
800-767-9999
Threaded Inserts, Plastic Knobs

Woodsmith Store
515-255-8979
Hock Plane Blades

Woodworker's Supply
800-645-9292
Anti-kickback Router Bits

Woodworkers' Store
800-279-4441
Threaded Inserts, Plastic Knobs

ORDER INFORMATION

BY MAIL

To order by mail, use the order form that comes with the current issue. The order form includes information on handling and shipping charges, and sales tax.

If the mail order form is not available, please call the toll free number at the right for more information on specific charges and any applicable sales tax.

BY PHONE

For fastest service use our Toll Free order line. Open Monday through Friday, 7:00 AM to 7:00 PM Central Time.

Before calling, have your VISA, MasterCard, or Discover Card ready.

1-800-444-7527

Note: Prices subject to change after May 1, 1994.

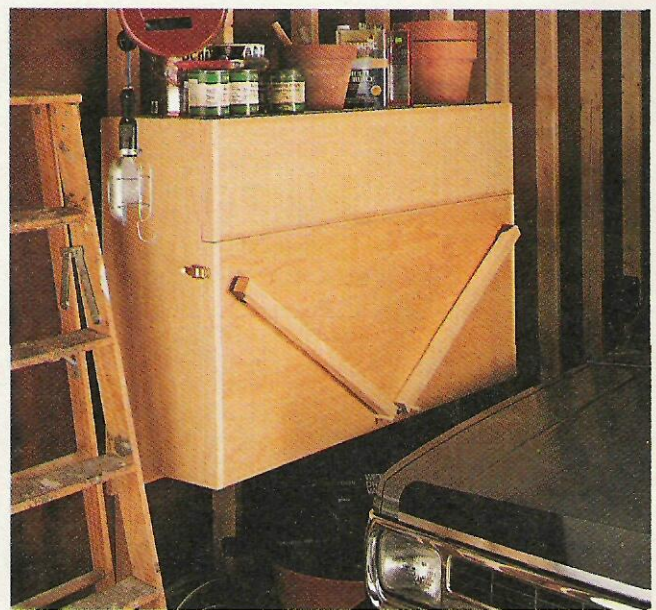
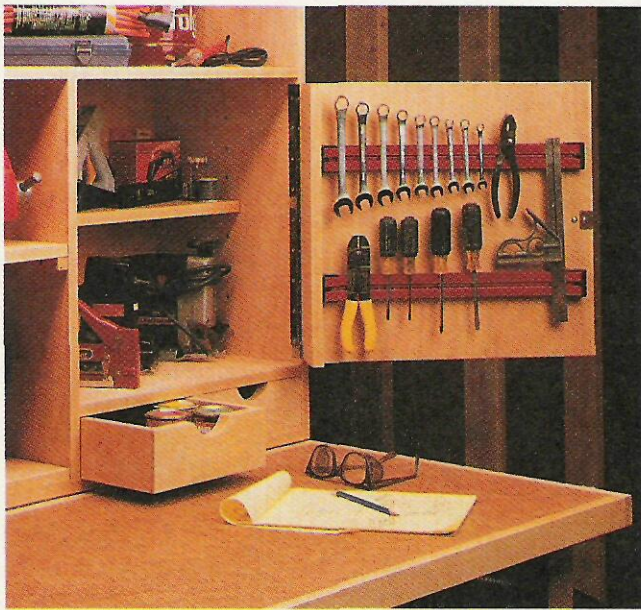

Scenes From the Shop

Whether it's used out in the garage as a workbench, or down in the basement for your favorite hobby, this Fold-Down Work Center offers a large work surface, a

built-in shop light, and plenty of storage. And best of all, to "close up" shop at the end of the day, all you have to do is just lift up the front and fold in the legs.