

TIPS • TOOLS • TECHNIQUES

# ShopNotes®

Vol. 3

Issue 17

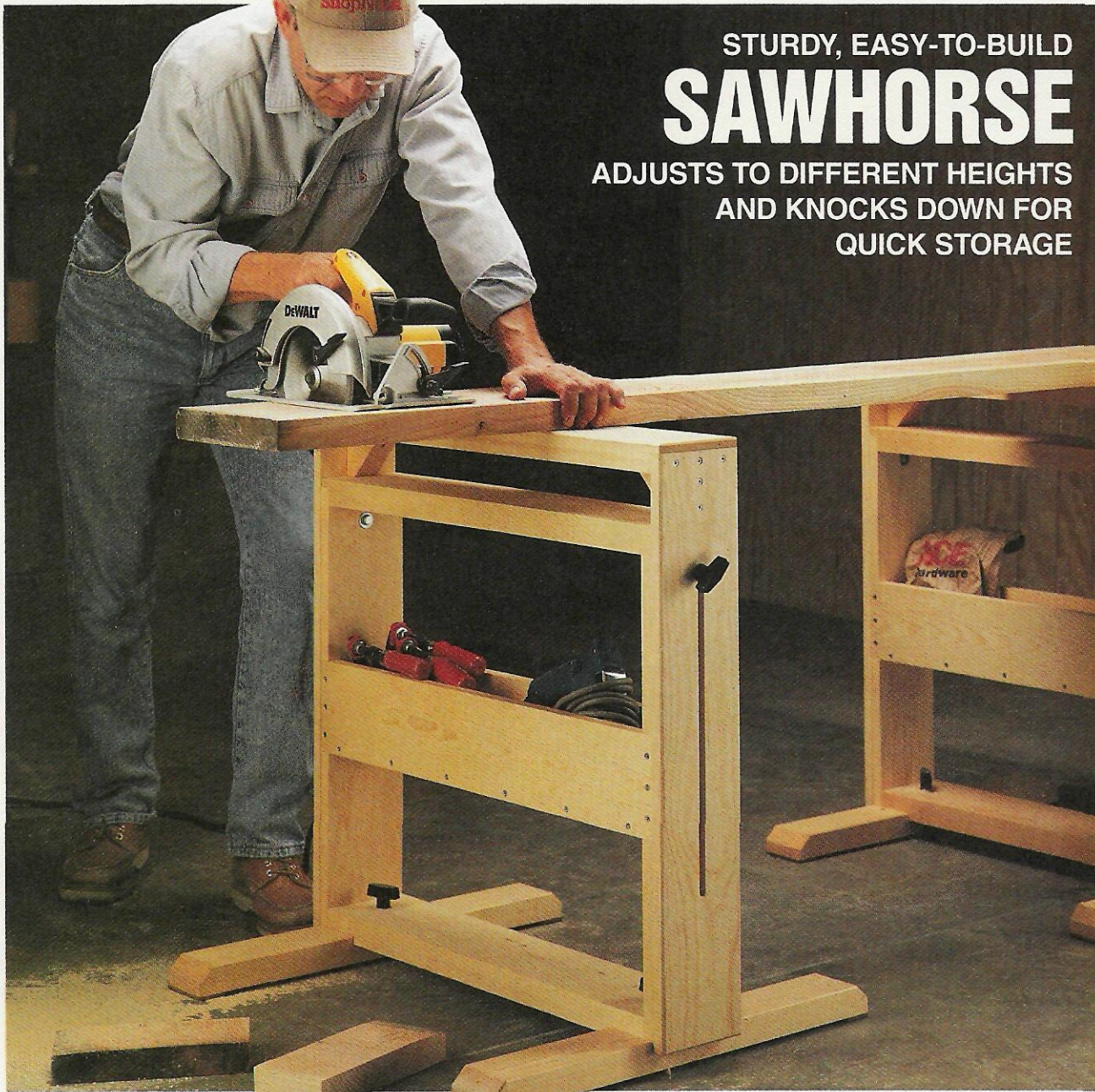

STURDY, EASY-TO-BUILD  
**SAWHORSE**

ADJUSTS TO DIFFERENT HEIGHTS  
AND KNOCKS DOWN FOR  
QUICK STORAGE

- Combination Layout Tool
- Containing Shop Noise
- Lumber Storage Rack
- Cutting Tapers on a Jointer



# ShopNotes

Issue 17 September 1994

**EDITOR** Donald B. Peschke  
**EXECUTIVE EDITOR** Douglas L. Hicks  
**MANAGING EDITOR** Richard S. Peters  
**ASSOCIATE EDITOR** Tim Robertson  
**ASSISTANT EDITOR** Phil Totten  
**CONTRIBUTING EDITOR** Mark A. Williams

**CREATIVE DIRECTOR** Ted Kralicek  
**ART DIRECTOR** Cary Christensen  
**SENIOR ILLUSTRATOR** Kurt Schultz  
**ILLUSTRATORS** Will Niskanen  
 Roger Reiland  
 Mark Higdon  
**PHOTOGRAPHER** Crayola England

**DESIGN DIRECTOR** Ken Munkel  
**SENIOR DESIGNERS** Jan Hale Svec  
 Kent Welsh  
**SHOP MANAGER** Steve Curtis  
**SHOP ASST./FACILITIES** Steve Johnson

#### CIRCULATION

*Circulation Director:* Liz Bredeson • *Subscription Manager:* Phyllis Jessen • *Circulation Analyst:* Rod Cain • *Newsstand Sales:* Kent A. Buckton

#### PUBLISHING SERVICES

*Manager:* Gordon C. Gaippe • *Graphic Artist:* Cheryl L. Cynor

#### CORPORATE SERVICES

*Controller:* Robin Hutchinson • *Accounting:* Laura Thomas • *Bookkeeping:* Julie Greenlee • *Production Manager:* Carol Quijano • *Info. Services Manager:* Joyce Moore • *Elect. Pub. Coordinator:* Douglas M. Lidster • *App. Specialist:* Linda Morrow • *Support Assistant:* Nick Thielen • *Admin. Assistants:* Cheryl Scott, Julia Fish • *Recept.:* Jeanne Johnson • *Building Maint.:* Ken Griffith

#### PROJECT SUPPLIES

*Marketing Director:* Robert Murry • *Art Director:* Cindy Jackson • *Fulfillment Mgr.:* Valerie Wiese • *Catalog Products Manager:* Bob Baker • *Inventory Control/Prod. Manager:* Mark Mattussi • *Project Supplies:* Linda Jones • *Tech. Support:* Jeff Janes • *Recept.:* Cynthia Kerman

#### CUSTOMER SERVICE

*Supr.:* Jennie Enos • *Cust. Serv. Reps.:* Jennifer Murphy, Joy Krause, Sara Kono, Anna Cox, Kristi Andrews, Lonnie Algreen, Karla Cronin

#### SHIPPING DEPARTMENT

*Supervisor:* Nancy Johnson • *Fulfillment:* Gloria Sheehan, Don McVey, Chuck Carlson, Sylvia Carey

ShopNotes® (ISSN 1062-9696) is published bimonthly (Jan., March, May, July, Sept., Nov.) by Woodsmith Corporation, 2200 Grand Ave., Des Moines, IA 50312. ShopNotes® is a registered trademark of Woodsmith Corp. ©Copyright 1994 by Woodsmith Corporation. All rights reserved.

**Subscriptions:** Single Copy, \$4.95. One year subscription (6 issues), \$19.95. Two years (12 issues), \$35.95. Canada/Foreign, add \$5.00 per year.

**Second Class Postage Paid** at Des Moines, IA and at additional offices.

**Postmaster:** Send change of address to ShopNotes, Box 11204, Des Moines, IA 50340-1204

**Subscription Questions?** Call 1-800-333-5854, 8am to 5pm, Central Time, weekdays.

PRINTED IN U.S.A.

## EDITOR'S NOTE

# Cutoffs

**A**n inner voice. Over time, many woodworkers develop a voice that “speaks” to them about safety. It occurs whenever a hand tool is picked up, or a machine is turned on.

**TAKE A STEP BACK.** Usually it happens when you’re getting ready to make a cut on a small or narrow workpiece. And just as you reach to turn on the power, something inside tells you to stop and take a step back. You begin to wonder if there isn’t another way to make this cut — a safer way.

It’s ironic that most of the craftsmen I know who have hurt themselves in the shop have heard this voice. And unfor-

tunately (for one reason or another) — chose to ignore it. For some it was late in the day. “I’ll just make this last quick cut.” And for others it was, “I know this isn’t safe, but I’m experienced.”

**LISTEN.** The secret to developing a voice like this is simple. Listen to it every time you hear it. Even if what you’re doing is something you’ve done a thousand times before. Maybe there’s a loose knot that you didn’t pay attention to. But your subconscious did. And if you make the cut, the knot could explode and cause an injury.

**A SIDE BENEFIT.** In addition to keeping all your fingers, there can be (and often is) an unexpected side benefit to being safety conscious. A good example of this is the Combination Layout Tool shown on page 12.

It started out as just a simple marking gauge. Two short pieces of hardwood held together with a sliding dovetail. When it came time to rout the dovetail in these small pieces, something inside me said it was unsafe.

So I decided to cut extra-long pieces to provide a better, safer grip when routing. Then after I was done, I’d just trim the pieces to length. Nothing mind-boggling here. Just common sense.

**THE SCRAPS.** But what about those scraps? It seemed a real shame to pitch them into the trash can. After all, there was a perfectly good sliding dovetail cut in them. That’s when it hit me. By sliding the head of the marking gauge onto the long cutoff bottom piece, it would make a nice beam compass.

All it would take would be a couple of holes and a simple pivot point. The resulting tool ended up as two tools in one — a

marking gauge and a beam compass.

Not only that, when I trimmed the top piece to length, I ended up with a cutoff that could be used as a spare head. Instead of holding a pencil, I drilled a hole in this spare head to accept an X-Acto knife. Now I can score a line on a workpiece. And even cut circles and arcs in posterboard for patterns. (For more on this, see page 12.)

**CUTOFFS.** Just as I find it hard to discard little bits and scraps of wood, I also find it difficult to throw away tidbits of information.

There are always a number of interesting “scraps or cutoffs” that don’t make it into the articles in an issue. The inside story on how and why a project or jig was designed — like the Combination Layout Tool.

But I feel that the story is worth telling. And so just like those scraps in my shop, I save the “Cutoffs” from the articles in each issue, and they find a place here. That’s how this column ended up with its name.

*Develop an inner voice  
about safety . . . listen to it  
every time you hear it.*

# Contents

## Jigs & Accessories

### Combination Layout Tool \_\_\_\_\_ 12

*This unique tool combines a marking gauge to lay out joinery, and a beam compass to draw large arcs and circles.*

### Band Clamp \_\_\_\_\_ 26

*All it takes is a few hours to build this shop-made band clamp. It's ideal for clamping large or odd-shaped projects.*

## Projects

### Adjustable Sawhorse \_\_\_\_\_ 4

*A versatile sawhorse that raises up and down to handle almost any job. Then knocks down for compact storage.*

### Lumber Storage Rack \_\_\_\_\_ 16

*This sturdy storage rack provides easy access to all your long boards, short cutoffs, and sheet goods.*

## In the Shop

### Cutting Tapers on a Jointer \_\_\_\_\_ 8

*Get crisp, clean tapers on a jointer without using any special jigs or complicated layout procedures.*

### Containing Noise in the Shop \_\_\_\_\_ 22

*A step-by-step approach to treating ceilings and walls so noise from the shop won't slip through.*

### Aniline Dyes \_\_\_\_\_ 30

*Clear, bright colors that can be mixed to match an existing color make aniline dyes worth a close look.*

## Departments

### Shop Solutions \_\_\_\_\_ 28

*Six shop-tested tips from our readers.*

### Sources \_\_\_\_\_ 31

*Hardware and supplies for projects in this issue.*

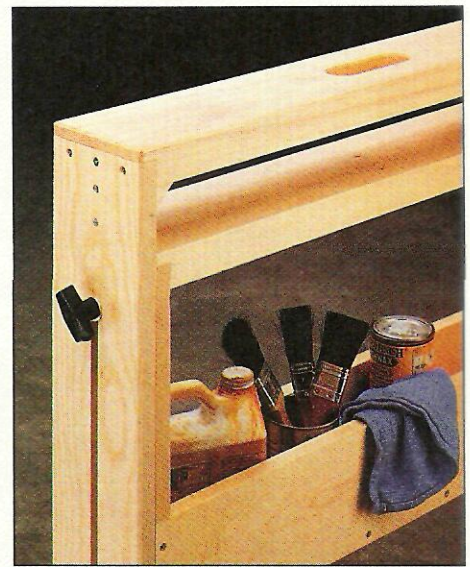

Adjustable Sawhorse page 4

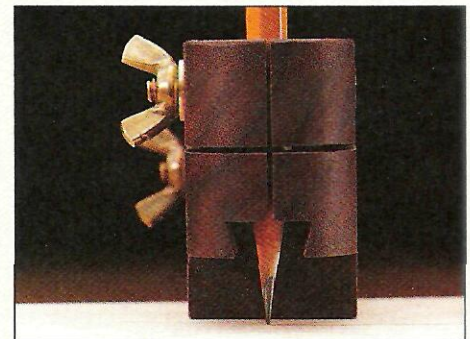

Layout Tool page 12



Lumber Storage Rack page 16

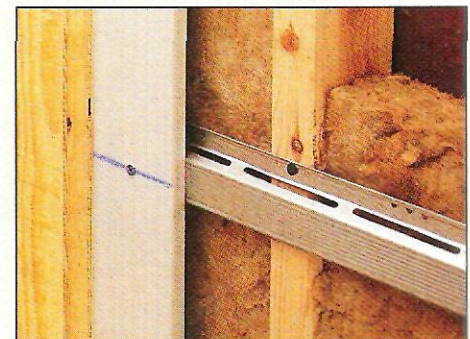

Containing Noise page 22

# Adjustable Sawhorse

*This sturdy, yet lightweight sawhorse is adjustable over a wide range of heights. And can be knocked down for compact storage in just a few seconds.*

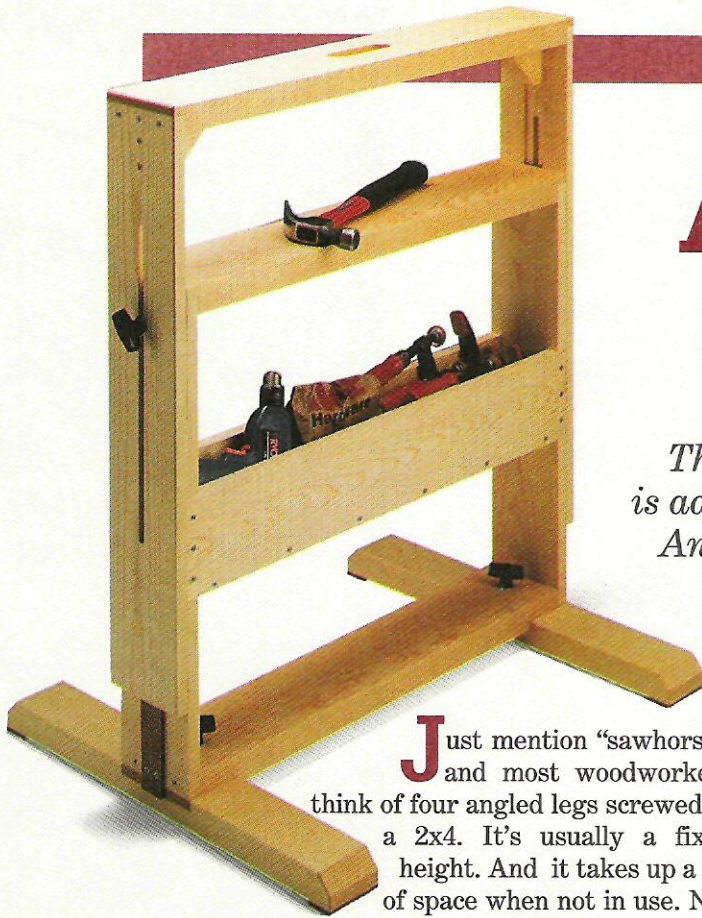

Just mention “sawhorse,” and most woodworkers think of four angled legs screwed to a 2x4. It’s usually a fixed height. And it takes up a lot of space when not in use. Not exactly the handiest thing for a shop.

But when Steve Johnson (our shop assistant) needed a new pair of sawhorses, he got together with Kent Welsh (one of our project designers) to come up with a different design, see photo above.

**ADJUSTABLE.** There were a couple features Steve wanted on the new sawhorse that our old sawhorse didn’t have. First it had to be adjustable so it could double as a “third hand” to support longer workpieces when working with the drill press or band saw, see photo A.

Kent solved this with a design that allows the sawhorse to be lowered or raised for heights rang-

ing from around 30" to 45", see photo B.

**COMPACT.** Also, because our shop is beginning to get crowded, Steve wanted a sawhorse that would take up the least amount of space when not in use.

Kent’s solution was a design that allowed the feet to be quickly removed. When knocked down, the sawhorse is narrow enough to hang on the wall or lean against it, see photo C. And to store the feet when the sawhorse isn’t being used, Kent added a tray centered between the legs that’s large enough to hold both feet. When assembled, the tray can be used to hold tools or containers of finish.

**PORTABLE.** Another nice thing about this sawhorse is it’s made from common construction lumber. This type of lumber makes it sturdy and strong, yet light enough to be portable. And to make it even easier to move from one power tool to the next (or out to the driveway), Kent added a handy slot in the top to serve as a handle.

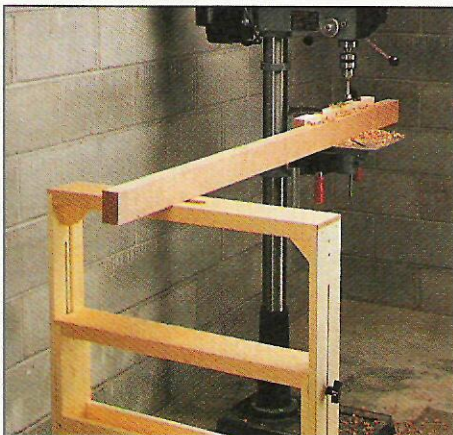

**A. Work Support.** This sawhorse can support a long workpiece when working at the drill press or band saw.



**B. Adjustable Height.** To adjust the height, just loosen the knobs on the sides and raise or lower the sawhorse.

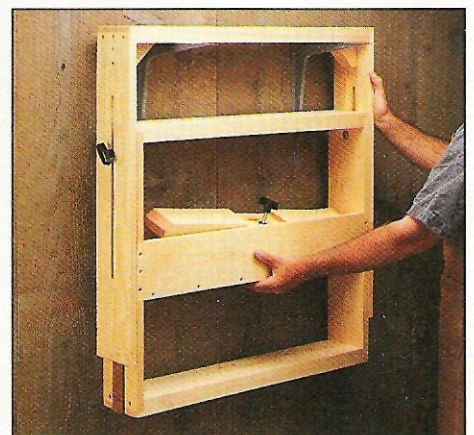

**C. Compact Storage.** When it’s not in use, you can knock down the sawhorse and store the feet in the tray.

**EXPLODED VIEW**  
**OVERALL DIMENSIONS:**  
 24"W x 30<sup>1</sup>/<sub>16</sub>"L x 30"H

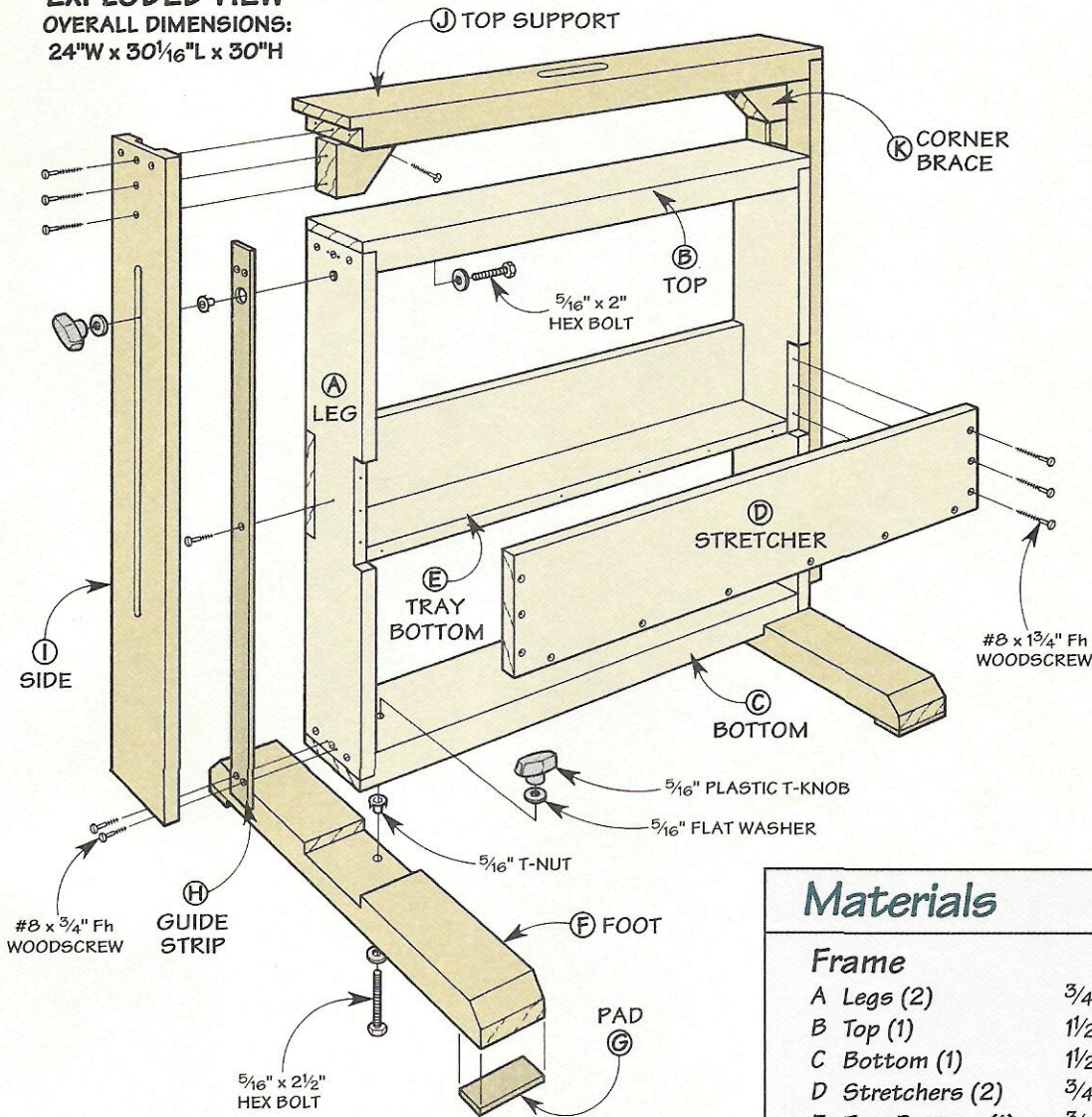

**Hardware**

- (10) #8 x 3/4" Fh Woodscrews
- (48) #8 x 1<sup>3</sup>/<sub>4</sub>" Fh Woodscrews
- (2) 5/16" x 2" Hex Bolts
- (2) 5/16" x 2<sup>1</sup>/<sub>2</sub>" Hex Bolts
- (4) 5/16" T-nuts
- (8) 5/16" Flat Washers
- (4) 5/16" Plastic T-knobs

**Materials**

**Frame**

- |                   |  |
|-------------------|--|
| A Legs (2)        | 3/4 x 5 - 24                                       |
| B Top (1)         | 1/2 x 5 - 28 <sup>1</sup> / <sub>2</sub>           |
| C Bottom (1)      | 1/2 x 5 - 28 <sup>1</sup> / <sub>2</sub>           |
| D Stretchers (2)  | 3/4 x 5 - 28 <sup>1</sup> / <sub>2</sub>           |
| E Tray Bottom (1) | 3/4 x 3 <sup>1</sup> / <sub>2</sub> - 27           |
| F Feet (2)        | 1/2 x 3 <sup>1</sup> / <sub>4</sub> - 24           |
| G Pads (4)        | 1/2 x 3 <sup>1</sup> / <sub>4</sub> - 1/4 Masonite |

**Support**

- |                     |   |
|---------------------|---|
| H Guide Strips (2)  | 1/2 x 25 - 1/4 Masonite   |
| I Sides (2)         | 3/4 x 5 - 28 <sup>1</sup> / <sub>2</sub>                            |
| J Top Support (1)   | 1/2 x 5 - 30 <sup>1</sup> / <sub>16</sub>                           |
| K Corner Braces (2) | 1/2 x 2 <sup>1</sup> / <sub>2</sub> - 3 <sup>1</sup> / <sub>2</sub> |

5" x 25" - 1/4" MASONITE

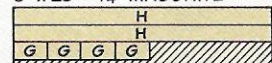

**Cutting Diagram**

**NOTE:** ALL PARTS MADE FROM CONSTRUCTION GRADE LUMBER OR NO. 2 PINE.

2 x 4 - 5' LONG

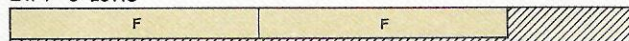

1 x 6 - 7' LONG



2 x 6 - 8' LONG

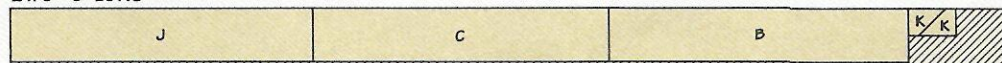

1 x 6 - 10' LONG



# Frame & Feet

The sawhorse consists of two main parts: a rectangular frame that provides a stable platform, and an adjustable support that slides over the frame to allow you to adjust to different heights.

**FRAME PARTS.** The frame is a simple four-sided box that consists of two *legs* (A), a *top* (B), and a *bottom* (C), see Fig. 1.

To make a sawhorse that was both strong and lightweight, I used 3/4"-thick No. 2 pine for the top and bottom.

The legs sit in rabbets cut in the ends of the top and bottom, see Fig. 1a.

Before gluing and screwing them in place, there's one more thing to do. You need to cut two notches centered on the length of the legs for a pair of stretchers (D) added later, see Fig. 2. These notches are 5" long and cut to match the thickness of the stretchers, see Fig. 2a.

**TRAY.** Next, to add lateral support to the frame, I cut two *stretchers* (D) from 3/4"-thick stock to fit the notches in the legs. These stretchers also create the sides of a storage tray that's a handy place to store hand tools and hardware.

To complete the tray, just cut a 3/4"-thick *tray bottom* (E) to fit between the stretchers (D) and

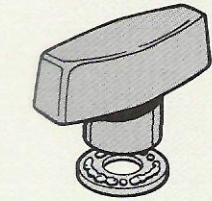
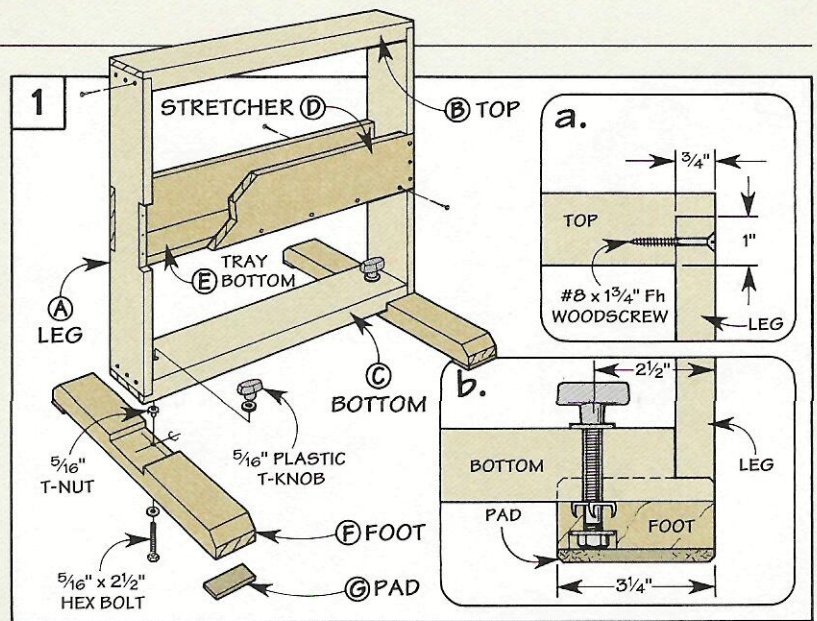

To avoid losing the washer, epoxy it to the T-knob.

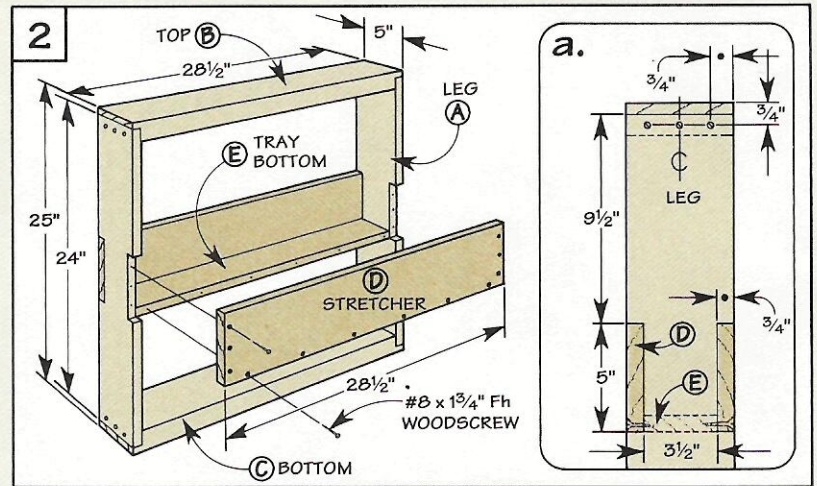

the legs (A), see Fig. 2. Then glue and screw it in place.

**FEET.** With the frame complete, all that's left is to add a pair of feet, see Fig. 3. The feet sup-

port the sawhorse and prevent it from tipping over during use. The *feet* (F) are just short lengths of 2x4 notched to fit under the frame.

To prevent the sawhorse from rocking on an uneven floor, *pads* (G) cut from 1/4" Masonite are glued to the bottom of each foot, see Fig. 3. To eliminate the sharp corners on the feet, a 3/4" chamfer is cut on each end, see Fig. 3.

Since I wanted to be able to quickly attach or remove the feet, each foot is held in place with a hex head bolt and a plastic T-knob (or a wing nut), see Fig. 3a.

Finally, I added a T-nut to prevent the bolt from turning as the knob is tightened.

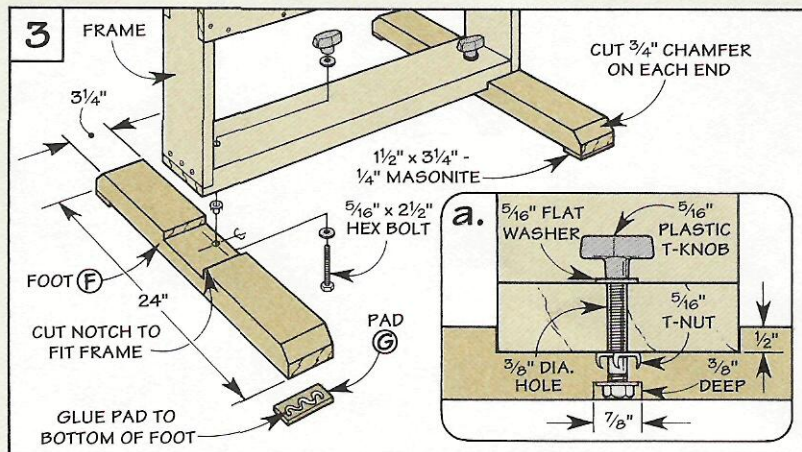

# Support

With the frame complete, you could stop now if all you need is a fixed-height sawhorse.

But since I wanted one that adjusted to different heights I added a U-shaped support that slips over the frame, see Fig. 4.

**GUIDES.** The support rides on two *guide strips* (H) screwed to the sides of the frame. They're cut from 1/4" Masonite to match the height of the frame, see Fig. 5.

**SIDES.** Once the guide strips are in place, you can begin work on the support. It consists of two sides and a top support. The *sides* (I) are the same width as the legs. But to allow room for two corner braces added later, they're 3 1/2" longer than the height of the frame (28 1/2"), see Fig. 4.

**SLOTS & GROOVES.** The next step is to cut a groove and a slot in each side, see Fig. 4. The groove is cut to fit over the guide strip and allows you to raise or lower the support without twisting. The slot is for a bolt and T-knob that are used to lock the support at the desired height.

**TOP SUPPORT.** The sides are attached to a *top support* (J) that's cut 1 9/16" longer than the

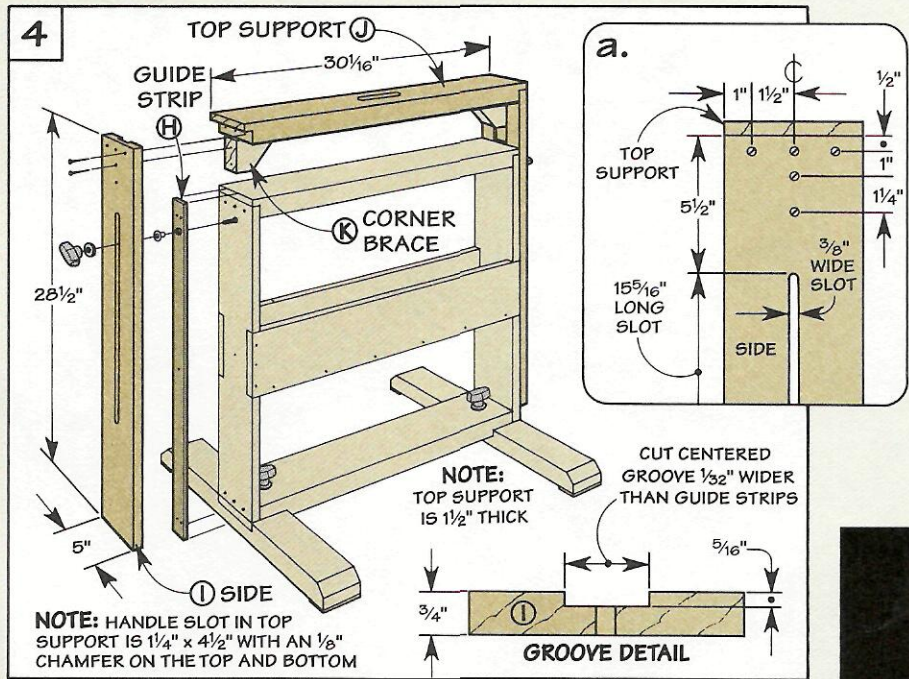

width of the frame, see Fig. 4. This allows for rabbets that are cut to join the top support to the sides. And 1/16" for clearance so it'll slide easily, see Fig. 6.

Finally, to prevent the support from racking, I added a *brace* (K) in each corner, see Figs. 6 and 6a.

**ASSEMBLY.** Now you can attach the hardware that allows you to adjust the height, see Fig. 6a.

Start by first sliding the support over the frame. Then locate and drill a hole through each leg (A) for the 5/16" hex bolt, see Fig. 6a and margin tip at right.

Here again, I used a T-nut to keep the bolt from spinning. It sits in a counterbored hole drilled in each Masonite guide strip (H).

Finally, replace the support and install the hardware.



With the support pushed all the way down, use a brad point drill bit to locate the hole for each hex bolt.

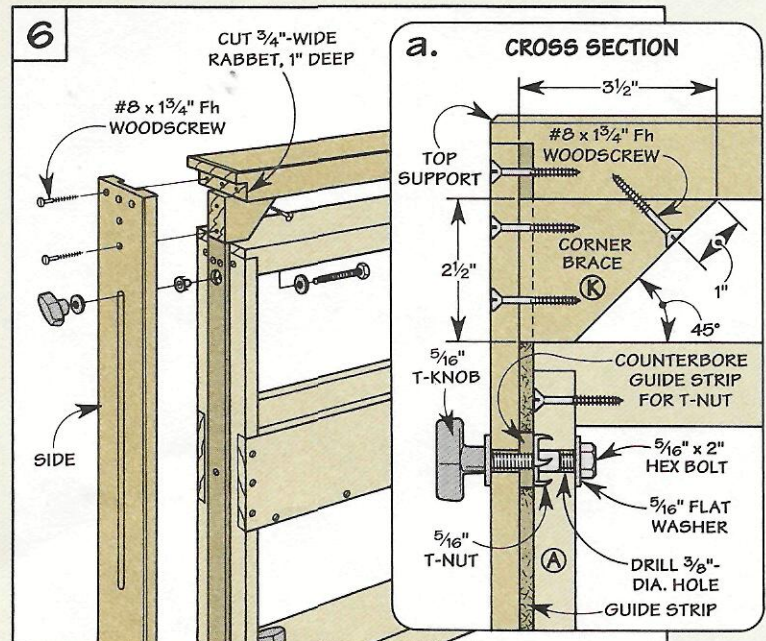
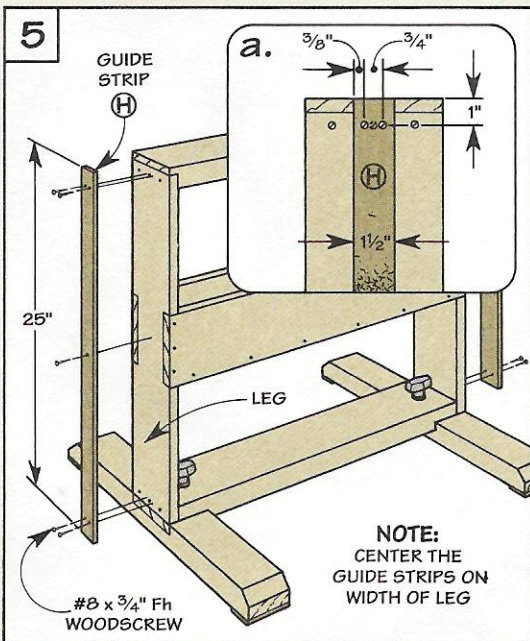

# Cutting Tapers

## on a Jointer

*No special jigs and a simple layout make it easy to cut perfect tapers on a jointer.*

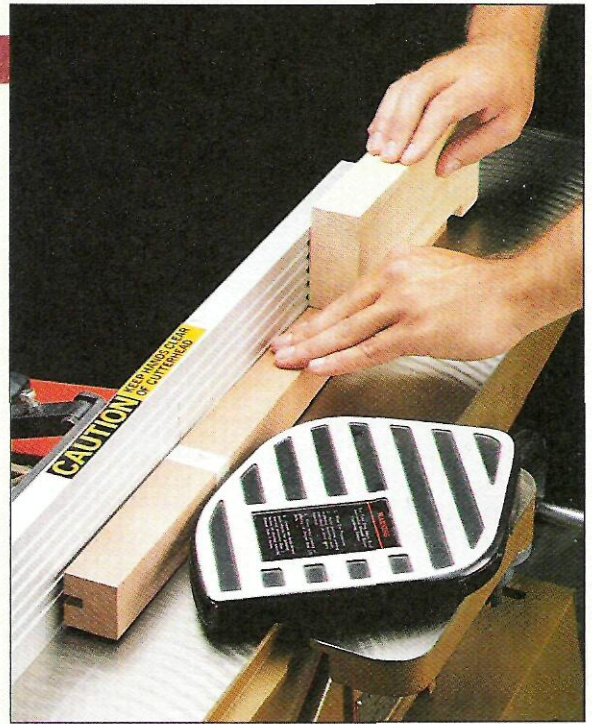

**N**ormally you think of using a jointer to get a straight edge on a workpiece. But it's also an ideal tool for cutting perfect tapers.

One reason is a jointer produces a clean, crisp cut that needs little (if any) sanding. And unlike a table saw, it doesn't require any special jigs or complicated layout procedures.

Depending on the design of the project, I typically cut two different types of tapers. One is a long, graceful taper that extends most of the way down the leg, see photo at left. The other is a short taper on the bottom end of the

leg. (For more on cutting short tapers, refer to page 10.)

### LONG TAPERS

When cutting a long taper, I don't taper the entire leg. Instead, there's a flat at the top where the leg is joined to another piece. Note: It's best to complete any joinery on the leg *before* it's tapered.

**LOWER WORKPIECE.** With the joinery complete, you're ready to taper the leg. The basic idea is simple. Instead of starting the cut at the end of the workpiece, it's lifted up, pushed forward, then *lowered* onto the cutterhead. The trick is knowing where

to lower the workpiece on the table to start the cut.

**REFERENCE LINES.** To do this, I make *two* reference lines. One marks the start of the taper, see Step 1. And to allow for a final clean-up pass later, the other line indicates the *front* edge of the outfeed table, see Step 2. When the two marks align, the workpiece is lowered onto the cutterhead.

**SNIBE.** Since the workpiece is coming down at an angle, the thing to be aware of is the knives will create a dished cut (snipe) at the beginning of the cut. To prevent this, I wrap two layers of masking tape around the leg, see

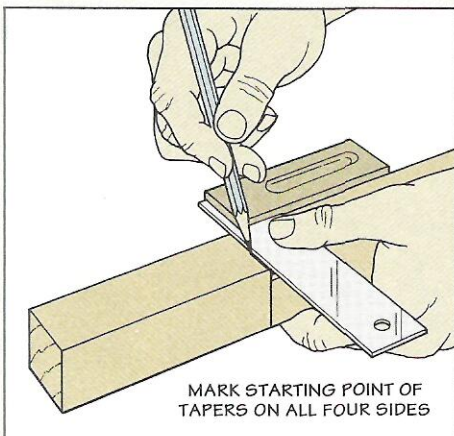

**Step 1:** Using a try square, lay out the starting point of the tapers around all four sides of the leg.

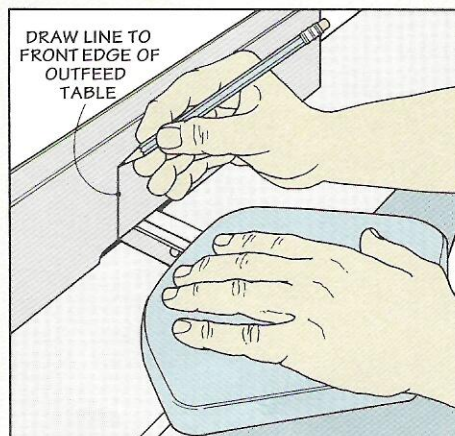

**Step 2:** Now make a pencil mark on the jointer fence to indicate the front edge of the outfeed table.

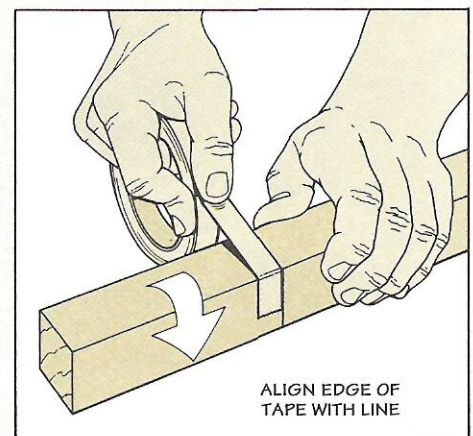

**Step 3:** To prevent the jointer knives from making a "dished" cut, wrap two layers of masking tape around the leg.



Step 3. This raises the workpiece just enough above the cutterhead to produce a smooth cut.

**DEPTH OF CUT.** Another thing to keep in mind is the depth of cut. In theory, start with the amount of taper you want at the end of the leg and divide it by the number of cuts you plan to make. (For example, to produce a 1/4" taper, make two 1/8"-deep cuts.)

But in practice, to allow for the clean-up pass, I adjust the infeed table so the cut is a hair less (1/64"). (For a tip on setting the depth of cut, see top margin at right.)

**CUTTERGUARD.** Before making your first cut, it's a good idea to get a feel for opening the cutterguard with a workpiece. This takes some practice — with the jointer turned off. What I've found works best is to raise the end of the workpiece off the table and use it to nudge the cutterguard open, see Step 4.

**TEST CUT.** Once you get the feel of opening the cutterguard, check the setup by making a test cut. **Safety Note:** Be sure to hook a push block over the end of the leg when you make the cut.

**CUT TAPER.** Now you're ready to taper the actual workpiece. Depending on the depth of cut, you'll need to make several passes on each side, see Step 5. Since it's easy to lose track of the cutting sequence, I use a simple trick, see bottom margin at right.

**CLEAN-UP PASS.** All that's left to complete the tapers is to make a clean-up pass on each tapered side. The goal is to take as light a pass as possible, yet still cut the taper right up to the layout line.

To do this, remove the tape and raise the infeed table until the knives just graze the line at the start of the taper, see Step 6.

Finally, instead of lowering the workpiece onto the cutterhead, make a full-length pass with the leg riding on the tapered side, see Step 6.

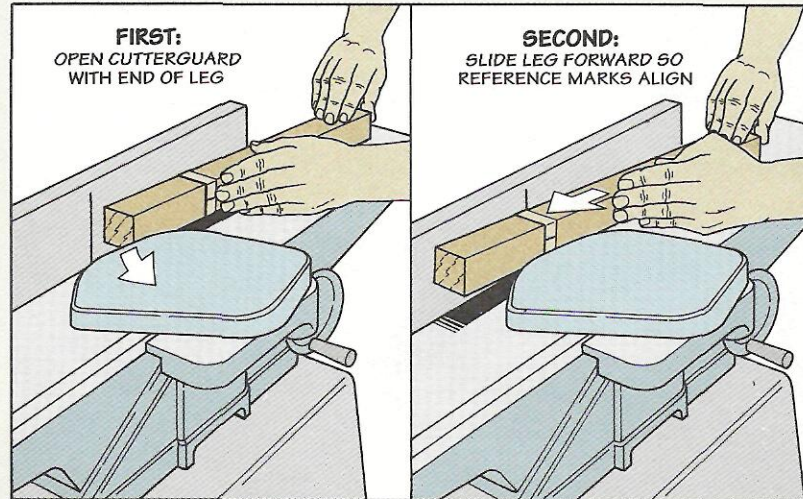

**Step 4:** With the leg against the fence, raise the end slightly above the table. Now nudge the cutter-guard open with the end of the leg and slide the workpiece forward until the reference marks align.

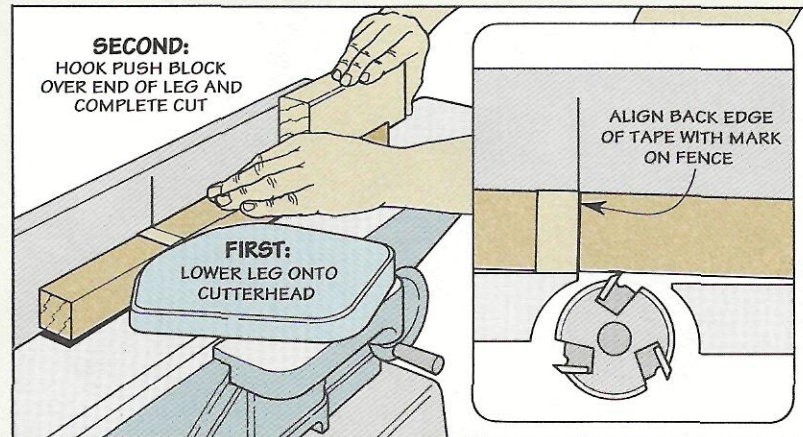

**Step 5:** When the back edge of the tape aligns with the mark on the fence, lower the leg down onto the cutterhead. Then hook a push block over the end of the leg and complete the cut.

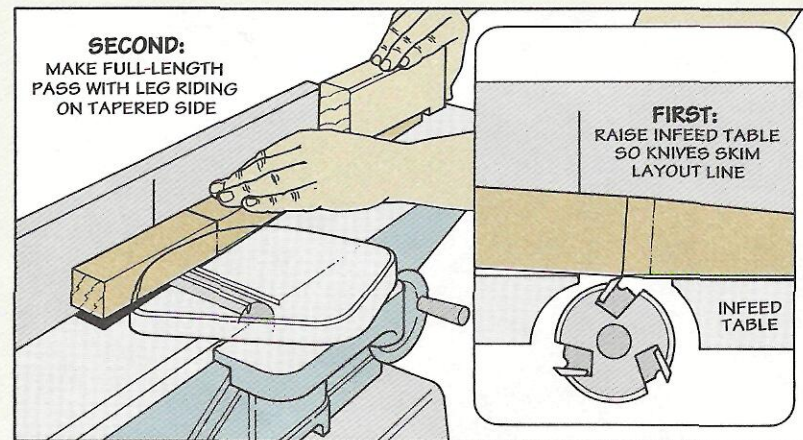

**Step 6:** With the tape removed, center the layout line on the workpiece across the opening in the jointer table. After raising the infeed table until the knives just graze the line, make a full-length pass.

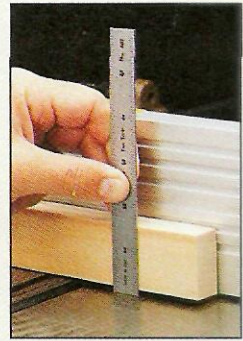

To determine the depth of cut, measure the gap between the infeed table and a straight stick laid across the outfeed table.



Marking numbers on the tape provides an easy way to keep track of the cutting sequence.

## Short Tapers

A second type of taper that's easy to cut on the jointer is a short taper. Here, the taper starts near the *bottom* of the leg and extends down to the end, see photo at left. To get a balanced look, I usually taper the two inside faces of a leg.

**LENGTH.** The length of the taper depends on two things: the throat opening of your jointer and the design of the project.

To keep the end of the leg from dropping down into the cutterhead, the taper must be *longer* than the throat opening of the jointer, see Step 1. Once you've established this, the length is just a matter of personal preference.

When cutting a short taper, you'd expect to repeat the same process as with a long taper. But since the taper starts so close to the bottom of the leg, this means my fingers would get too close to the cutterhead to make a safe cut. So I use a different approach.

**NIBBLE.** After marking the taper on the leg (Step 1), a series of passes is made to nibble away the material up to the line. Unlike a long taper, the amount of material removed with each pass isn't critical. Just don't get carried away — a shallow cut ( $\frac{1}{16}$ " or less) is best.

When making each pass, the untapered end of the leg is raised



▲ To cut a short taper, a block of wood raises the untapered end of the workpiece off the jointer while the opposite end rides across the cutterhead.

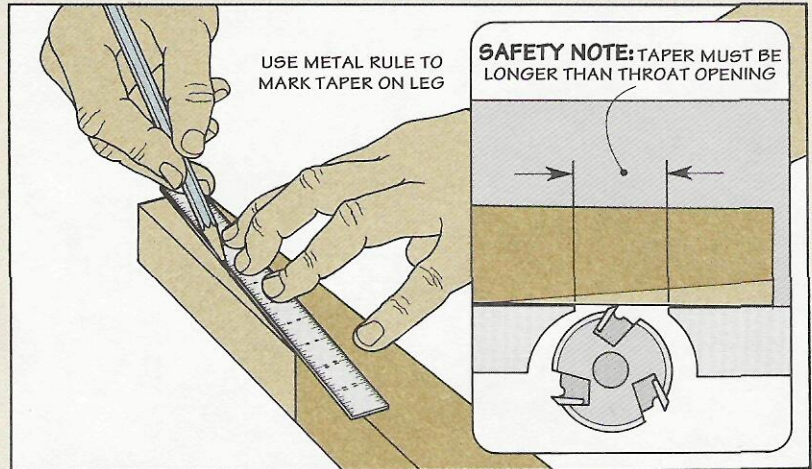

**Step 1:** Start by laying out the taper on the workpiece. Safety Note: To prevent the leg from dropping into the throat opening of the jointer table, the taper needs to be longer than the opening.

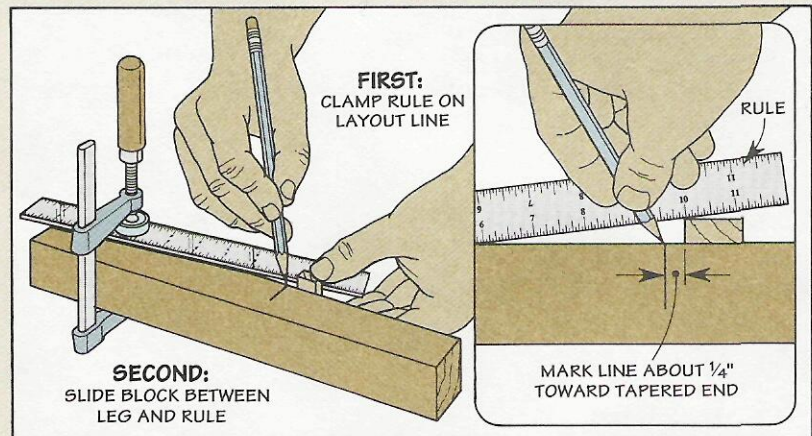

**Step 2:** Now slide a block between the leg and a metal rule clamped across the layout line. To leave the cut a bit short of the layout line, mark the leg about  $\frac{1}{4}$ " toward the end to be tapered.

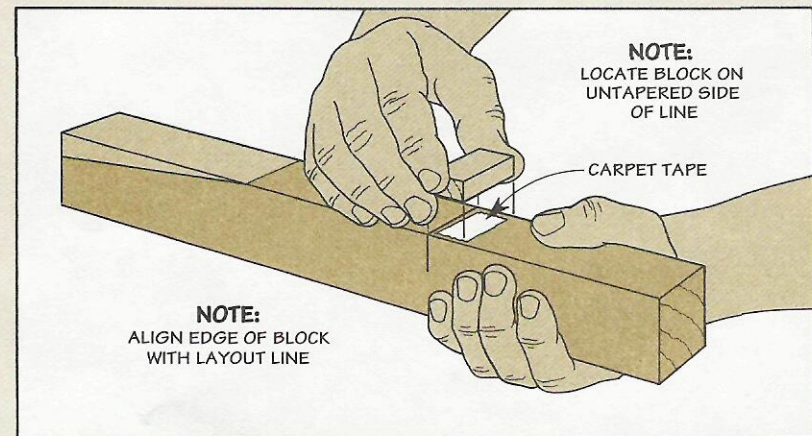

**Step 3:** The guide block is positioned on the untapered side of the layout line. With the edge of the block aligned with the mark, it's attached to the leg with double-sided carpet tape.

off the table at an angle, see bottom photo on opposite page. And the tapered end rides across the cutterhead.

**GUIDE BLOCK.** The key to making this work is to hold the leg at a *consistent* angle for each pass. To do this, I use a guide block that raises the leg off the table and maintains the angle.

There's no hard and fast rule about the thickness of this block. And the location is determined by clamping a metal rule across the layout line on the leg and slipping the block in between, see Steps 2 and 3. Note: To sneak up to the final taper (sanded later), the block is offset about 1/4".

**FLAT.** With the guide block in place, the next step is to cut a flat on the tapered end, see Step 4. To support the leg as it passes across the cutterhead, this flat needs to be long enough to span the opening in the jointer table.

**POSITION WORKPIECE.** Now you can position the leg on the jointer. *With the jointer turned off*, open the cutterguard and set the leg down so it straddles the opening, see Step 5. The important thing here is to make sure the knives won't contact the leg when you turn on the jointer.

**MULTIPLE PASSES.** Once the leg is positioned, it's just a matter of hooking a push block over the end and making as many passes as necessary to cut the taper, see Step 6. **Safety Note:** Make sure you turn the jointer off when repositioning the leg for each pass.

As you approach the layout line, the idea is to raise the infeed table to take a shallower cut. The final cut should just skim the line.

**CLEAN-UP.** Since the guide block was positioned to cut the taper a bit short of the layout line, you'll need to clean up the remaining material by sanding up to the line.

**TWO SIDES.** To taper the second side, simply reposition the block and repeat the process.

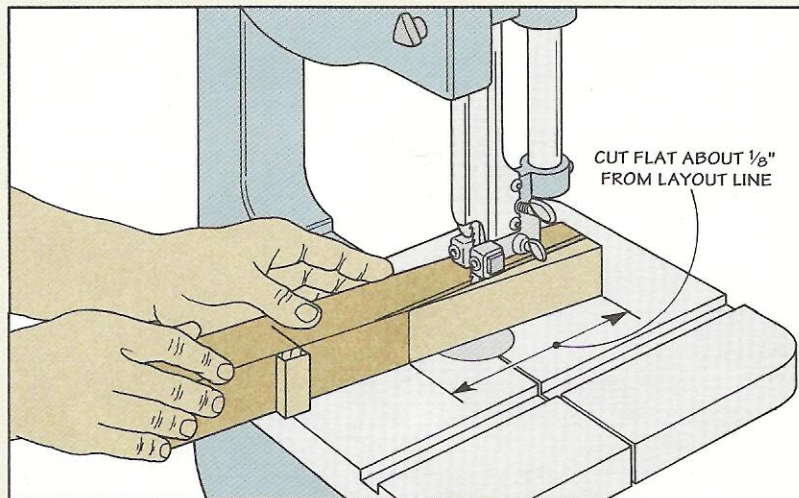

**Step 4:** Using a band saw (or hand saw) rough cut a flat on the leg that's about 1/8" from the layout line. This flat creates a support that spans the throat opening of the jointer table.

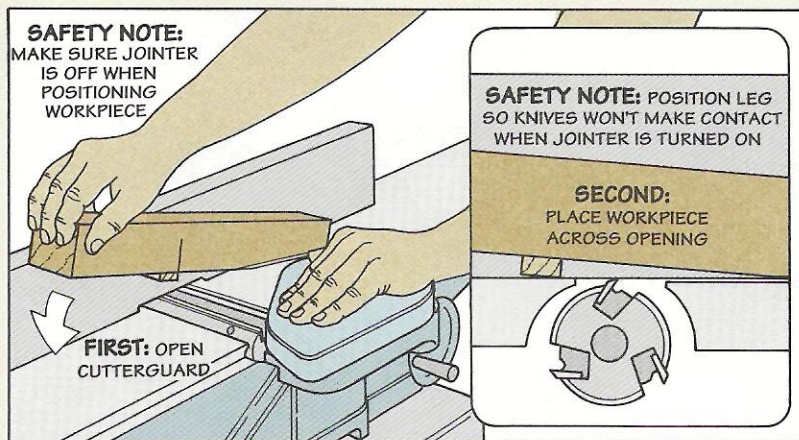

**Step 5:** With the jointer turned off, open the cutterguard and place the leg on the table so it straddles the opening. Then check that the knives won't contact the leg when the jointer is turned on.

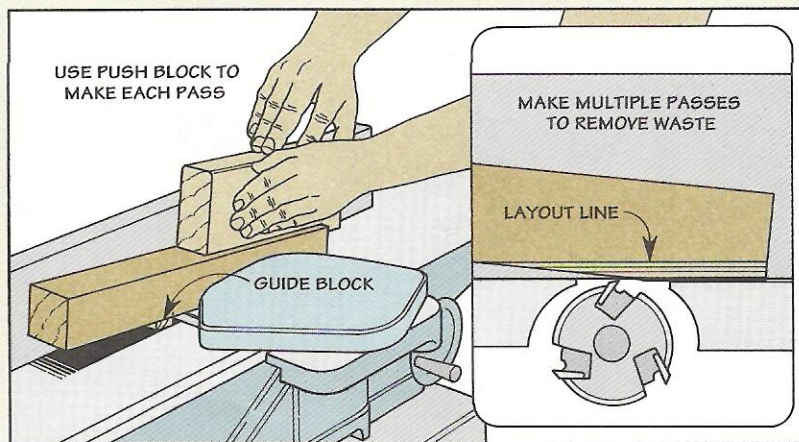

**Step 6:** Using a push block, successive passes are made to nibble away the waste material. As you approach the layout line, raise the infeed table to take a shallow cut that just skims the line.

# Combination Layout Tool

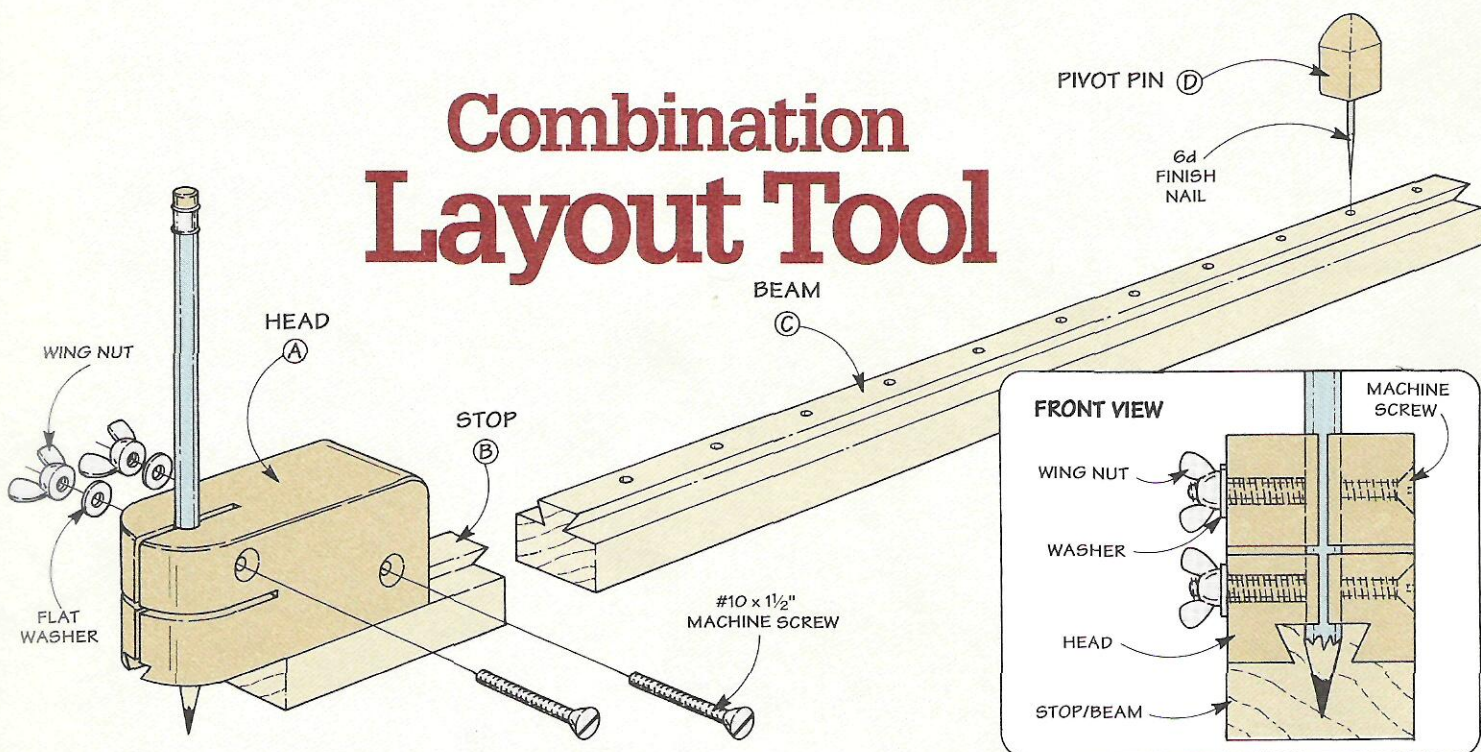

*This single tool serves as both a marking gauge and a beam compass.*

**A** marking gauge has always been my tool of choice when laying out joinery. It allows me to quickly and accurately lay out dovetails, mortises, and tenons. But a traditional marking gauge uses a steel pin to score the layout lines.

And this pin can sometimes catch and tear up the wood. Once the wood is scored, it's difficult to remove the line. So I decided it was time to improve on an old classic and make a new layout tool that would eliminate this problem.

**PENCIL.** The solution was simple. Replace the steel pin with pencil lead. This way, the line can be erased or sanded away quickly and easily. And it doesn't catch and tear the surface.

But I didn't want to fiddle around changing and

adjusting tiny pieces of pencil lead that break easily. So the head of the tool is designed to accept an ordinary pencil, see Drawing above and photo A.

**BEAM COMPASS.** When making the marking gauge, I discovered a unique use for the extra-long leftover scraps. (For more on this, see Cutoffs on page 2.) The end result was a marking gauge that could also be used as a beam compass — a combination layout tool. If you've never used one, a beam compass is great for laying out large arcs and large-diameter circles, see photo B.

**A KNIFE.** And if there's ever an occasion where you want to *score* a layout line or cut out a cardboard circle for a template, there's enough leftover material to make an extra head to hold an X-Acto knife, see photo C.



**A. Marking Gauge.** This marking gauge fits in the palm of your hand (or the pocket of your shop apron) and uses a pencil to produce highly visible lines.

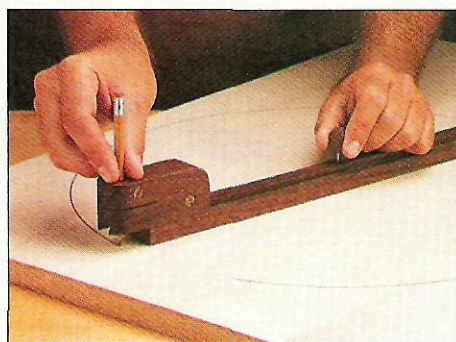

**B. Beam Compass.** When used as a beam compass, the layout tool allows you to lay out just about any size arc or circle you'll need.

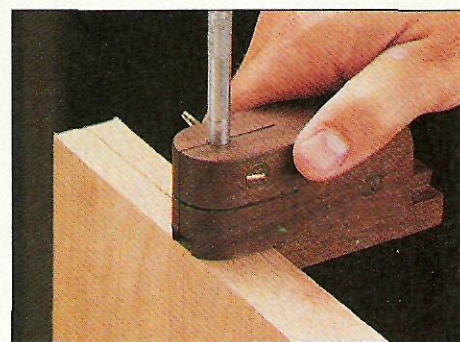

**C. Cutting Gauge.** Using the leftover material, you can make a second head to hold an X-Acto knife. This will allow you to score layout lines.

# Head

There are just four parts to the layout tool. A *head* and *stop* make up the marking gauge. And a long *beam* and a *pivot pin* convert the marking gauge into a beam compass, see Drawing on page 12.

**HEAD.** I started by making the head. It holds the pencil (or knife) and is grooved on the bottom to accept the stop or the beam.

**SLIDING DOVETAIL.** To hold the stop (or beam) to the head and still allow it to slide, I used a sliding dovetail. It's just a dovetailed groove (in the head) that mates with a dovetailed tongue (routed later on the stop and beam).

**EXTRA-LONG BLANK.** Because the head is so small, I started with an extra-long blank, see Fig. 1. Then use a 1/2" dovetail bit in the router table to rout the groove.

To keep the groove centered, it's best to rout the groove in two passes, flipping the workpiece in between each pass, see Steps 1 and 2 in Fig. 1.

Once the groove is cut, trim the head (A) to length, see Fig. 1.

**PENCIL.** The next step is to drill three holes in the head. The first is for the pencil and is drilled so it slides smoothly, see Fig. 2a.

The last two holes are for the machine screws added later. And drilling these is a little trickier.

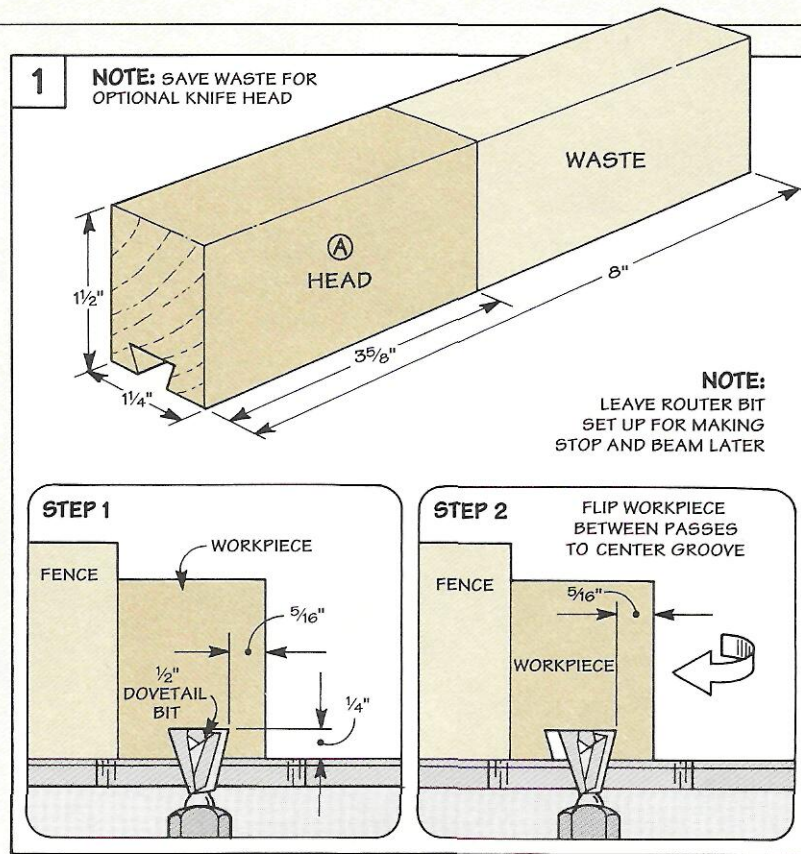

**MACHINE SCREWS.** When a wing nut on the end of each screw is tightened, kerfs (cut later) close up and cause the head to pinch the pencil and the stop.

To prevent the screws from turning when the wing nuts are tightened, pilot holes slightly smaller than the diameter of the screw are drilled through the

head, see Fig. 2a. This way, the head will cut it's own threads as it's installed.

Next, enlarge each hole halfway through the head, see Fig. 2a. (This allows the head to flex as the wing nuts are loosened or tightened.)

Finally, countersink each hole for the head of the screw.

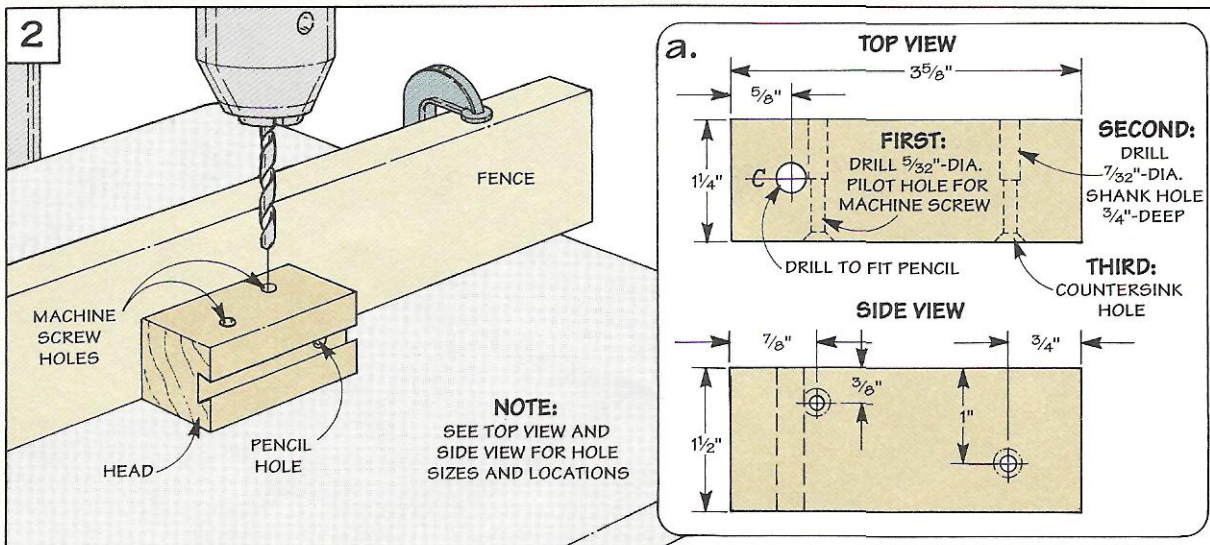

# Cutting the Kerfs

All that's left to complete the head is to cut kerfs so it can flex around the pencil and the stop (or beam), see Fig. 3. And shape the head to soften the corners.

## THREE KERFS

There are three kerfs to cut. The first allows the bottom half of the head to pinch the tongue on the stop (or beam) and lock it in place. The second kerf lets you pinch the pencil. And the third kerf splits the head into two sections so you can pinch the pencil without affecting the stop.

**FIRST KERF.** I found the best way to cut the kerfs was to use a hand saw. But you could use a hand saw.

The first kerf is centered on the dovetailed groove in the bottom of the head, see Fig. 3a. To cut this kerf, I used a stop block to control the depth of the cut, see Step 1. **Safety Note:** Use a push block to help guide the workpiece as you cut the kerfs.

**SECOND KERF.** To cut the second kerf, leave the fence in the same position. But adjust the stop block for a deeper cut, see Step 2 and refer to Fig. 3b.

Note: To keep the second kerf

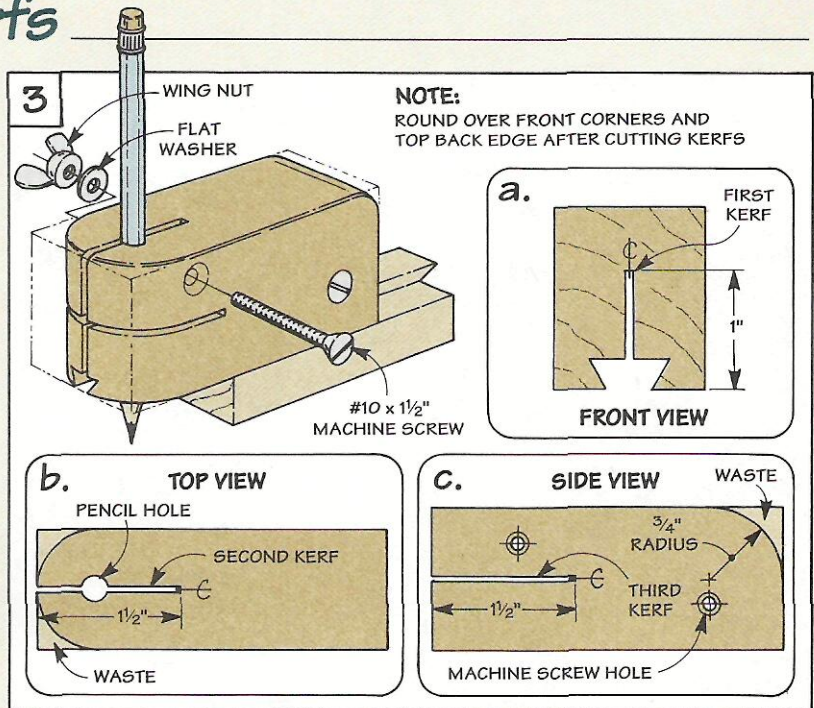

aligned with the first kerf, place the same side of the workpiece against the fence as you did when cutting the first kerf.

**THIRD KERF.** Now the kerf that splits the head can be cut. To do this, I first laid the head on its side so the pencil hole was parallel to the table top, see Step 3 and refer to Fig. 3c.

Then with the stop block in the same position as in Step 2, adjust the fence so the blade splits the

head into two equal sections.

**CONTOUR HEAD.** All that's left to complete the head is to soften the sharp edges and shape it to fit your palm, refer to Fig. 3.

To do this, first knock off the front corners and top back edge with the band saw. Then round over the edges with a drum sander or sanding block.

Finally, thread in the machine screws, and add the washers, wing nuts, and pencil.

## Step-By-Step

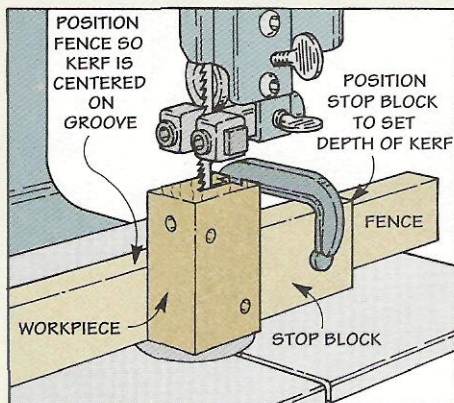

**Step 1.** The first kerf is centered on the dovetailed groove in the bottom of the head. I used a fence to center the kerf, and a stop block to set the depth of cut.

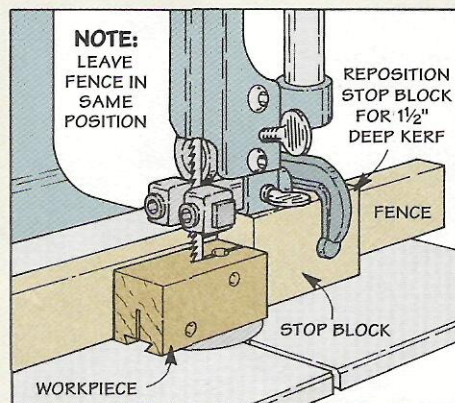

**Step 2.** To cut the second kerf, leave fence in same position, but adjust stop so kerf stops 1/2" from front of head. Place groove side of head on table top.

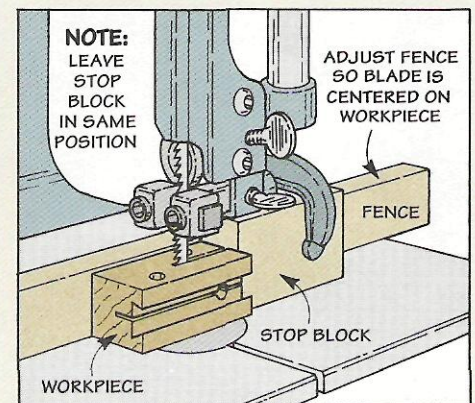

**Step 3.** Now the third kerf can be cut. Leave the stop block in the same position. But adjust fence so blade splits workpiece into two equal sections.

# Stop & Beam

With the head complete, the next step is to make the stop and beam. The stop and beam have a dovetailed tongue that fits into the dovetailed groove routed earlier in the head (A).

Again for safety, I made the stop and beam at the same time from an oversized blank, see Fig. 4.

**TONGUE.** The trick to getting the stop and beam to slide smoothly is to rout the tongue to fit the groove. What you want to end up with is a tongue that slides smoothly without a lot of play.

To get a perfect fitting tongue, I used the same setup used earlier when routing the groove and snuck up on the final fit. The height of the bit is the same, but for safety I "buried" the bit in the fence, see Fig. 5.

To sneak up on the tongue, start by routing one that's slightly wider than the width of the groove. Then sneak up on the finished width of the tongue until it fits the groove. Here again, it's best to flip the workpiece between passes so the tongue ends up centered on the blank.

When you're done routing the tongue, cut the 3"-long stop (B) from the blank to complete the

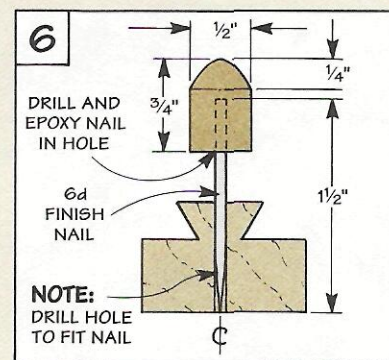
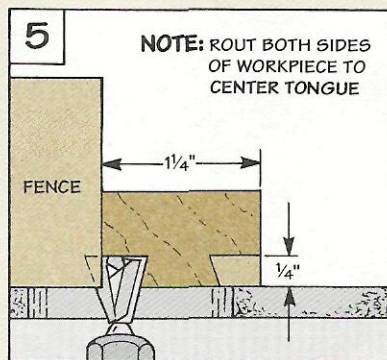
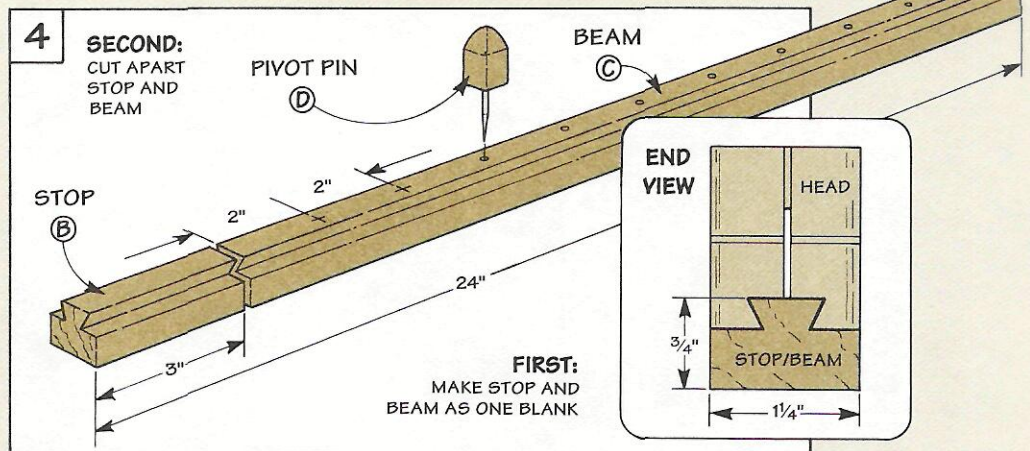

marking gauge, see Fig. 4.

The remaining part of the blank is the beam (C) for the compass. To complete the beam, drill a series of holes 2" apart to fit a pivot pin (D), see Fig. 4. (The last hole will end up 1" from the end.)

Now all that's left is the pivot pin.

**PIVOT PIN.** The *pivot pin* (D) is just a scrap block with a 6d finish nail epoxied in it, see Fig. 6. The top of the block is sanded to a gradual curve. And the nail is filed to a sharp point.

## Using the Combination Tool

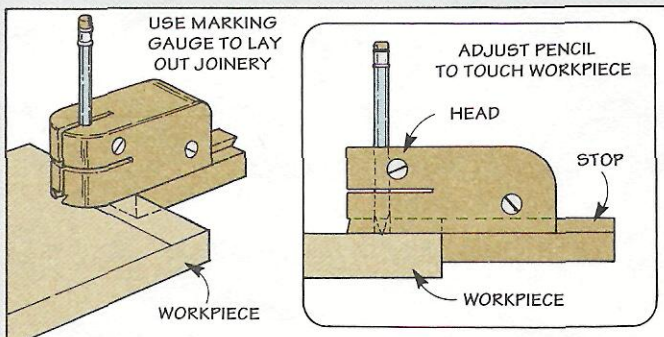

**Marking Gauge.** To set up the marking gauge, first adjust the pencil so lead just touches the surface of the workpiece. Then adjust the stop until it's the correct distance from the lead. Tighten the wing nuts after each step.

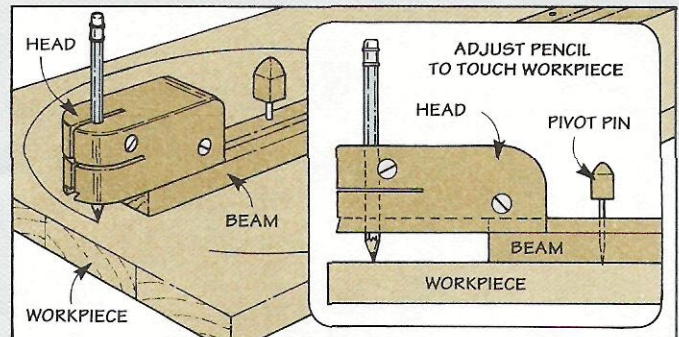

**Beam Compass.** To convert the marking gauge into a beam compass, replace the stop with the beam. Then place the pivot pin in the hole closest to the desired radius and adjust the head to mark the desired radius.

# Lumber Storage Rack

*This lumber rack provides a complete storage system with easy access to long boards, cutoffs, and sheet goods.*



**W**hen it comes to lumber, I'm like a squirrel storing nuts away for the winter. Whether it's a long board, a short cutoff, or a piece of hardwood plywood that's too valuable to throw away, it all ends up in my "storeroom."

Needless to say, storage is a problem. I'm either working around a stack of wood on the floor or sorting through it to find the right board. Not to mention bracing sheets of plywood against my leg while trying to pull out a piece from behind.

To get my lumber and plywood up off the floor, I built a simple rack, see photo above. Although it provides plenty of storage, the best thing about this rack is it organizes all my cutoffs and pro-

vides easy access to the piece I need.

**PIPES.** The key is a number of sturdy metal pipes that are supported by a wood frame, see Exploded View. A series of holes allows you to move the pipes up or down so you can customize the rack to fit your needs.

**STORAGE.** I laid my long boards flat across the top row of pipes. And to keep short pieces from falling through, they're stored on shelves supported by the other two rows of pipes. To create even more storage, I ran stretch cords across the bottom compartments, refer to page 20.

**OPTIONAL BIN.** Although you can build the rack as a separate unit (see the photo on the opposite page), there's also an optional bin that swings out to provide storage for plywood and sheet goods.

This bin is designed to hold pieces on edge. This way, you can shuffle through the pieces like you're looking through a filing cabinet and select the piece you need, see the photo above.

## Cutting Diagram

48" x 96" - 1/2" PLYWOOD

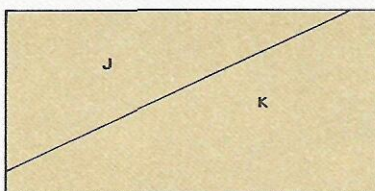

48" x 96" - 1/2" PLYWOOD

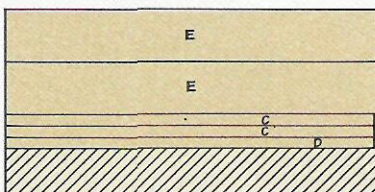

2 x 4 - 96" (TWO PIECES)



2 x 4 - CUSTOM LENGTH (FOUR PIECES)



1 x 6 - 96"

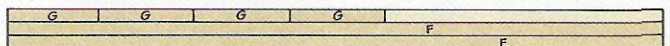

2 x 6 - 48"

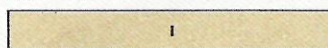

2 x 6 - 96"

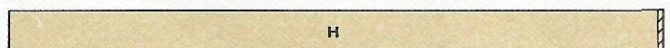



## EXPLODED VIEW

OVERALL DIMENSIONS:  
17½" W x 95½" L x CUSTOM HEIGHT

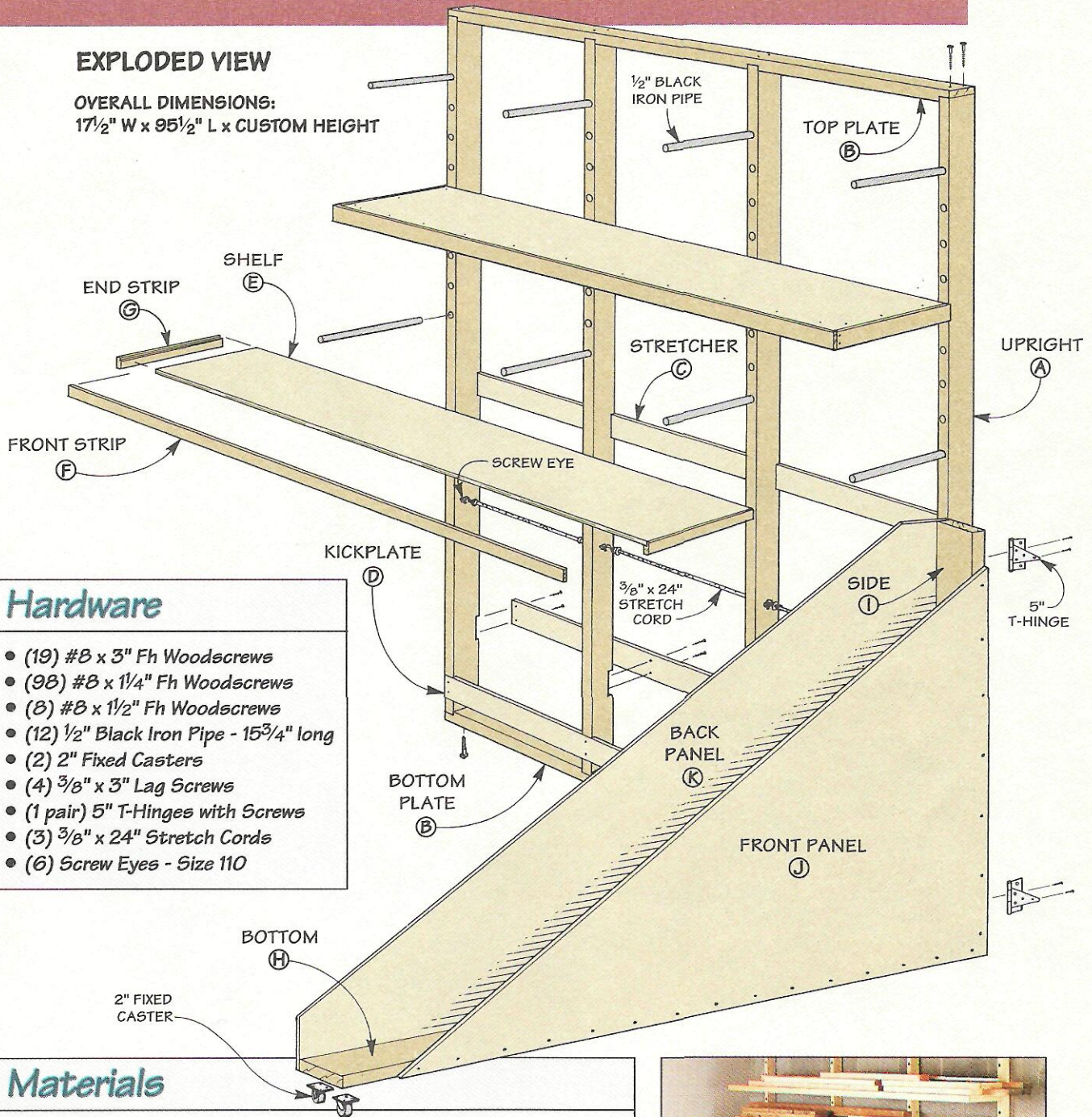

## Hardware

- (19) #8 x 3" Fh Woodscrews
- (98) #8 x 1¼" Fh Woodscrews
- (8) #8 x 1½" Fh Woodscrews
- (12) ½" Black Iron Pipe - 15¾" long
- (2) 2" Fixed Casters
- (4) ⅜" x 3" Lag Screws
- (1 pair) 5" T-Hinges with Screws
- (3) ⅜" x 24" Stretch Cords
- (6) Screw Eyes - Size 110

## Materials

### Lumber Rack

- |                          |                         |
|--------------------------|-------------------------|
| (A) Uprights (4)         | 1½ x 3½ - custom length |
| (B) Top/Bottom Plate (2) | 1½ x 3½ - 94½           |
| (C) Stretchers (2)       | 3 x 94½ - ½ Ply         |
| (D) Kickplate (1)        | 3 x 94½ - ½ Ply         |
| (E) Shelves (2)          | 13¾ x 95 - ½ Ply        |
| (F) Front Strips (2)     | ¾ x 15½ - 95½           |
| (G) End Strips (4)       | ¾ x 15½ - 13¾           |

### Plywood Bin

- |                     |                                  |
|---------------------|----------------------------------|
| (H) Bottom (1)      | 1½ x 5½ - 95                     |
| (I) Side (1)        | 1½ x 5½ - 48                     |
| (J) Front Panel (1) | 42 x 90 - ½ Ply (cut diagonally) |
| (K) Back Panel (1)  | 48 x 96 - ½ Ply (cut diagonally) |

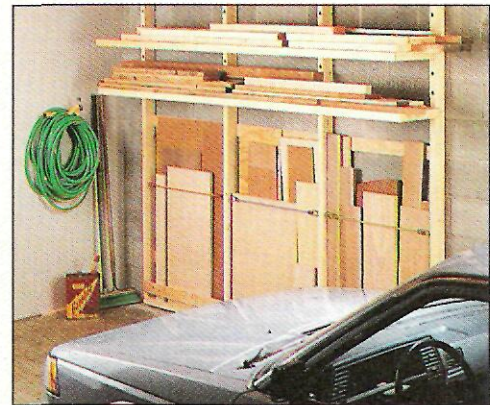

▲ If space is limited, you can build the storage rack as a separate unit. Even without the swing-out bin, the rack still provides plenty of storage.

# The Rack

The "backbone" of the lumber storage rack is a 2x4 stud wall that supports the pipes. You can either build a separate frame for this wall. Or, you can drill holes for the pipes in an existing stud wall, see box on opposite page.

**FRAME.** Basically, the frame consists of four *uprights* (A) that are held together by a *top* and *bottom plate* (B), see Drawing at right. (I used Douglas fir.)

Before determining the length of the uprights, you'll need to decide on the location of the lumber rack. Then, measure the shortest distance between the floor and the joists (or ceiling) and subtract 2½". This allows ½" for levelers (added later) and 2" for the thickness of the top and bottom plates after cutting the joinery that holds the frame together.

A pair of dados cut in the top and bottom plates accept the inside uprights, see Drawing in margin. And the outside uprights fit into rabbets cut in the ends of the plates.

**DRILL HOLES.** The next step is to drill holes in each upright to hold the pipes. These holes are drilled at a 3° angle, see Detail 'a' in Drawing above right. This way, when you install the pipes, they're raised at a slight angle to help keep the boards tight against the frame.

The size of the holes depends on the diameter of the pipe. Since I used ½" black iron pipe, I drilled ⅞"-dia. holes to accept the outside diameter of the pipe. (This pipe is available at most hardware stores.)

**STRETCHERS.** To keep the frame from racking (and to help secure

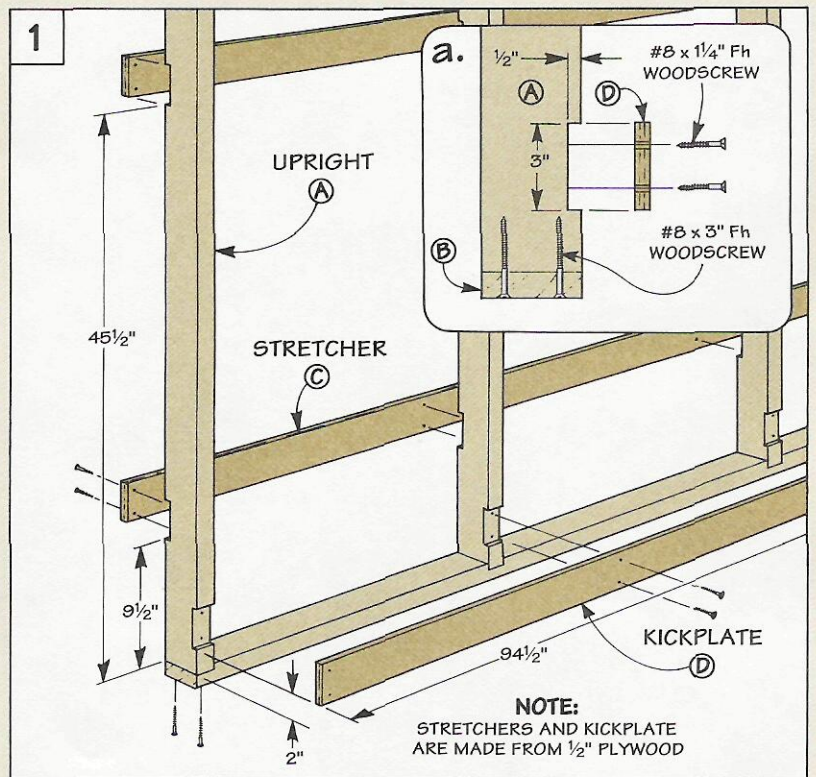
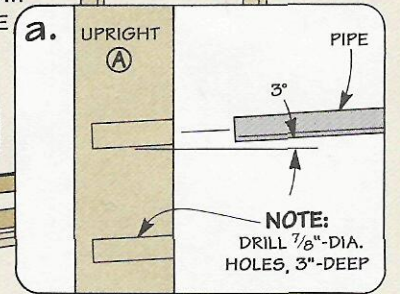
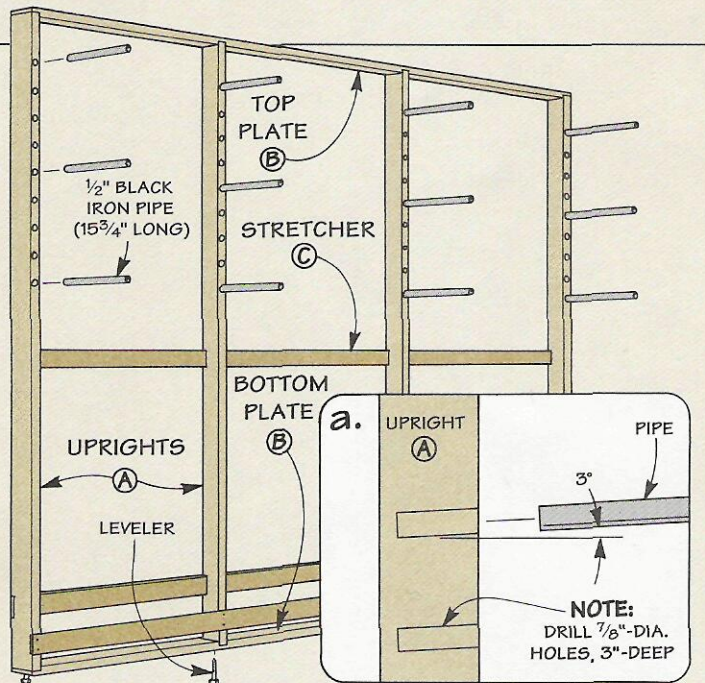
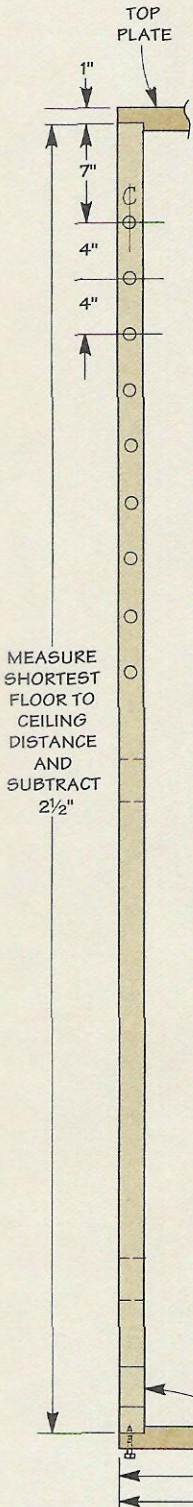

**NOTE:** STRETCHERS AND KICKPLATE ARE MADE FROM ½" PLYWOOD

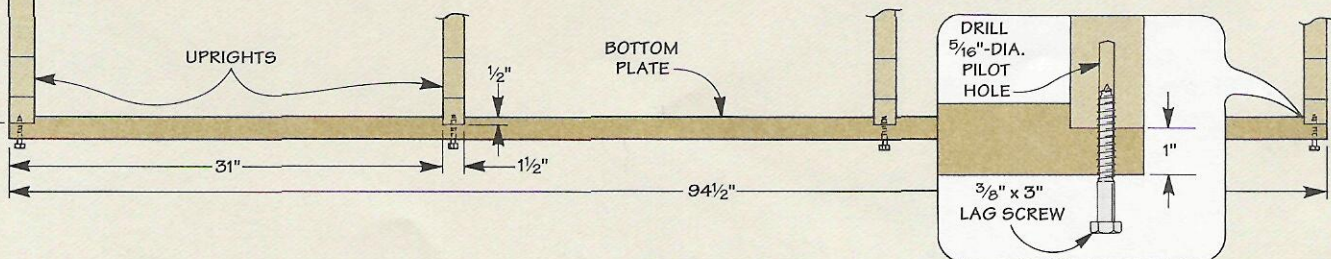

it against a wall later), the next step is to cut a pair of 1/2"-thick plywood *stretchers* (C), see Fig. 1. These stretchers fit in shallow dadoes that are cut in the back edge of each upright, see Fig. 1a.

**KICKPLATE.** While I was at it, I cut a 1/2" plywood *kickplate* (D), see Fig. 1. It holds short cutoffs in place when you stand them on end between the uprights. Here again, the kickplate fits in dadoes cut on the front edges of the uprights.

**ASSEMBLY.** Now you're ready to assemble the frame. This is just a matter of screwing the uprights to the top and bottom plates, see Fig. 1a. Then screw the stretchers and kickplate in place.

**LEVELERS.** To compensate for an uneven floor, I attached a leveler under each upright. These are nothing more than lag screws centered on the bottom ends of the uprights, see Margin Detail on page 18.

**INSTALLATION**

With the frame complete, it can be mounted to the ceiling and wall. The frame is held in place

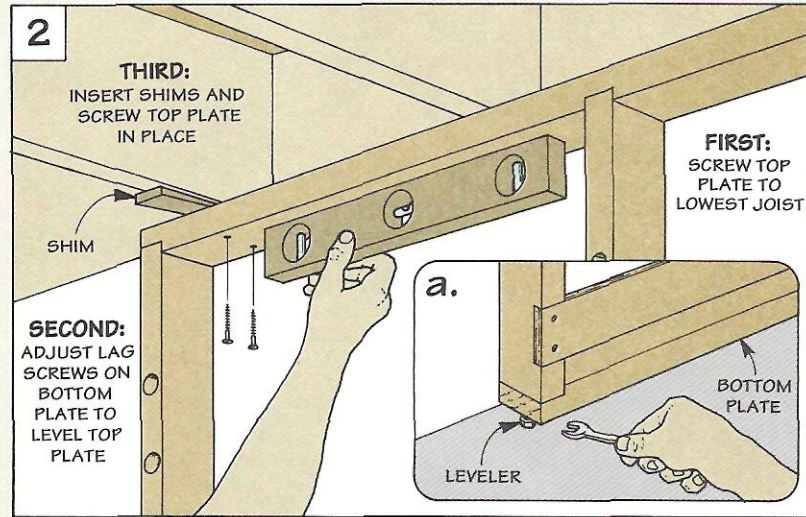

with screws that pass through the top plate into the ceiling joists.

The only problem is if the joists aren't all level across the bottom, the frame would end up out of square. The solution is simple — level the top plate.

Start by screwing the top plate to the *lowest* joist. Then level the top plate by adjusting the lag screws on the bottom of the frame, see Figs. 2 and 2a. Now just fit shims between the top plate and the "high" joists and

screw the frame in place.

For additional support, I also screwed the plywood stretchers (C) into the existing wall studs.

**PIPE.** All that's left is to add the lengths of black pipe. To provide three separate storage sections, I used twelve pieces of pipe (four for each section).

Note: Most hardware stores will cut the pipe to length for a small charge. Or you can buy longer lengths and cut it yourself with a hacksaw.

**Drilling Guide**

To drill a series of consistently angled holes with an electric hand drill, I use a simple guide that starts the bit at the correct angle. It's just a scrap 2x4 with a piece of Masonite glued to one side, see the Drawing at right.

First, a *straight* hole is drilled through the block. Then the back edge is cut at the desired angle. When you clamp the guide to the workpiece, the back edge tilts the hole at the same angle, see photo.

To help position the guide on a workpiece, the idea is to align *two* reference marks. These lines represent the centerlines of the holes in the workpiece and the drilling guide.

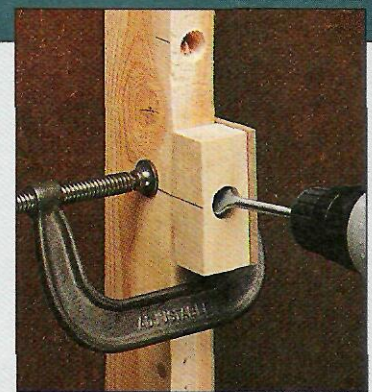
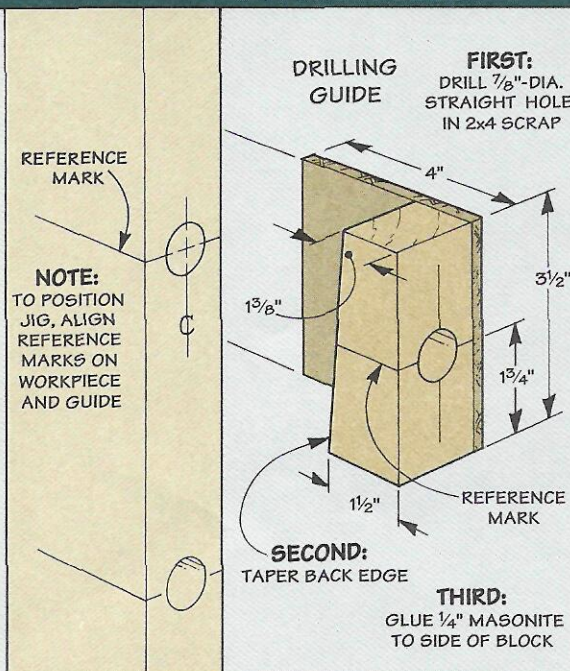

▲ When drilling an angled hole, this simple guide makes it easy to start the bit at the correct angle. Just clamp the guide in place so the angled back edge is against the stud. This raises the hole in the guide at a slight angle which helps position the drill bit.

# Shelves & Storage Compartments

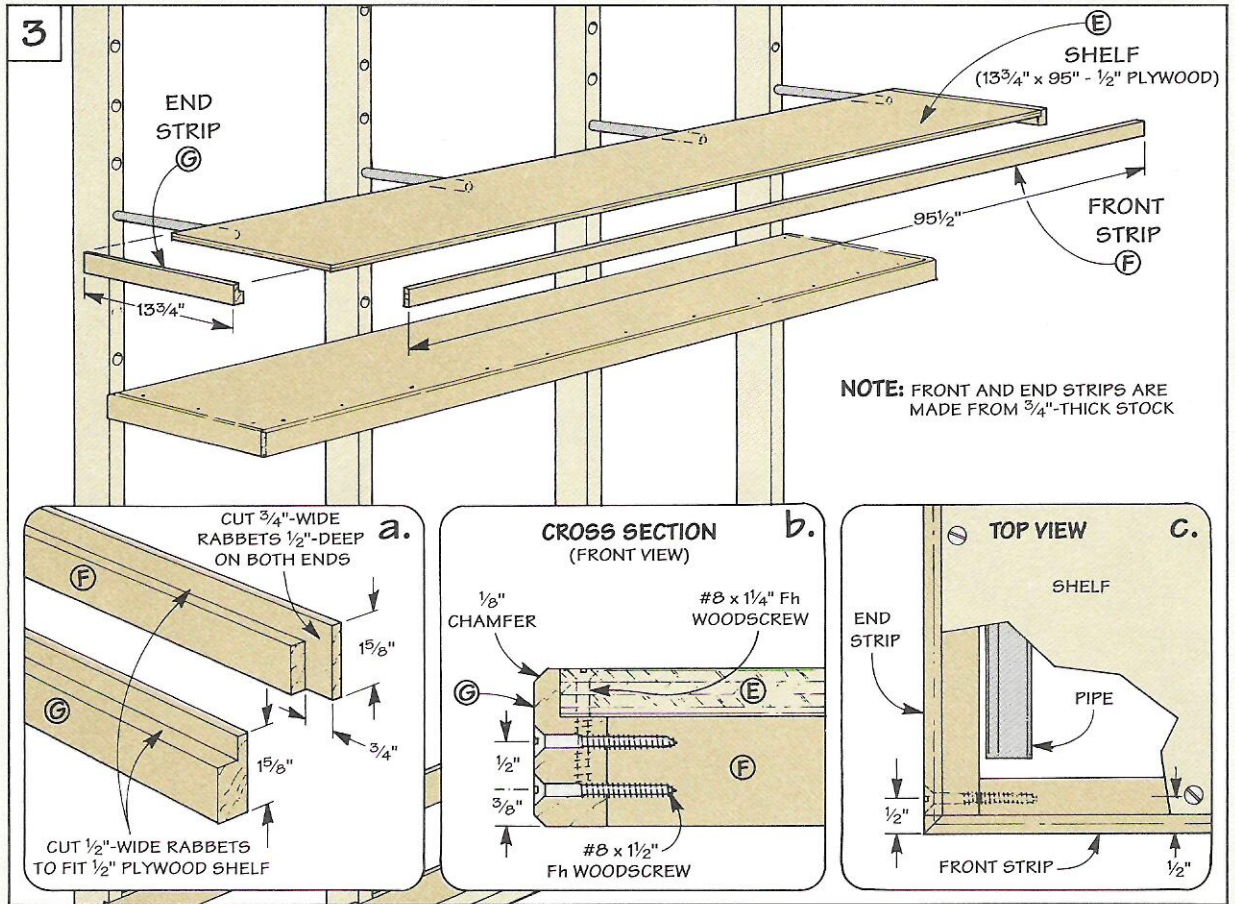

■ Although long boards can be stored easily across a row of pipes, short pieces can fall in between. So I added two plywood shelves that slip over the pipes.

**SHELVES.** Each shelf (E) is made from a piece of 1/2"-thick plywood, see Fig. 3. To help

strengthen the plywood and keep the shelves from sliding across the pipes when loading (or removing) a board, I added trim pieces on the front and ends of each shelf. Note: To allow the shelves to sit flat on the pipes, there's no trim piece on the back.

**TRIM.** The front (F) and end strips (G) are just pieces of 3/4"-thick stock, see Fig. 3. (I used pine.) Each strip has a rabbet cut in the top edge to accept the shelves, see Figs. 3a and 3b. But before attaching the shelves, there's one more thing to do.

**RABBET JOINT.** The strips are held together with a simple rabbet joint. This requires cutting a rabbet on each end of the front strip (F) to accept the end strips (G), see Fig. 3a and 3c.

**ASSEMBLY.** Now you're ready to assemble the shelves. After screwing the front and end strips

together, just set the shelves down in the rabbets and screw them in place, see Figs. 3b and 3c. Finally, to keep from accidentally "catching" the strips when loading a board, I routed a 1/8" chamfer on the top and bottom edges and set the shelves on the pipes.

## STORAGE COMPARTMENTS

In addition to the shelves, there's one other place that can be used for storage — the "compartments" between the uprights at the bottom of the rack.

These compartments are ideal for storing "shorts" or small pieces of plywood. While the kickplate (D) keeps these pieces from falling out of the bottom, you'll still need a way to secure the top ends. To hold these pieces in place (yet still make them easy to remove), I used a simple trick, see the photo at left.

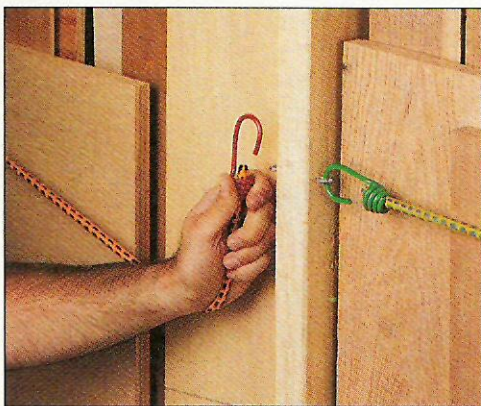

▲ To hold "shorts" in place, I installed screw eyes in the uprights and ran stretch cords across the storage compartments.

# Optional Bin

If you work with a lot of sheet stock, you can add the optional bin. It has an open, triangular shape that lets you shuffle through the pieces to find the one you want. And it swings out from the frame for easy loading and unloading.

Basically, the bin has two main parts: an L-shaped frame and two plywood panels, see Fig. 4.

**FRAME.** The frame consists of a *bottom (H)* and *side piece (I)* that are made from 2x6's (Douglas fir), see Fig. 4. After cutting a rabbet in the bottom end of the side piece, the frame is simply screwed together, see Fig. 4a.

**PANELS.** To form the sides of the bin, the next step is to add the *front (J)* and *back panels (K)*. Both panels are cut from a single sheet of 1/2"-thick plywood, see Fig. 5. Note: To make it easy to see what's in the bin, the front panel is *smaller* than the back.

**ATTACH PANELS.** After cutting the panels to size, I applied a bead of construction adhesive to the edges of the frame and screwed the panels in place. Note: To swing the bin out opposite the way it's shown in Fig. 6, turn the L-shaped frame end for end and reverse the direction of the panels.

**CASTERS AND HINGES.** To allow the bin to swing out, the open end

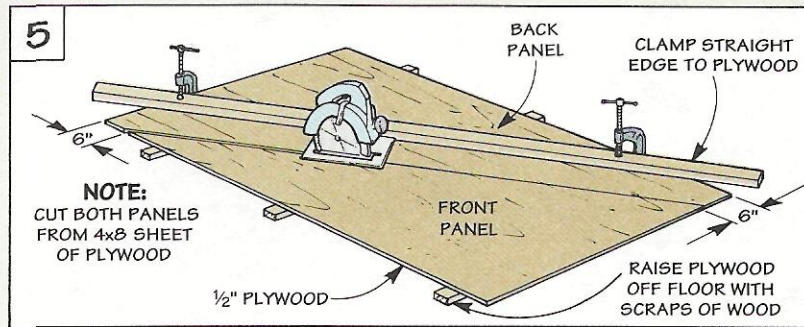
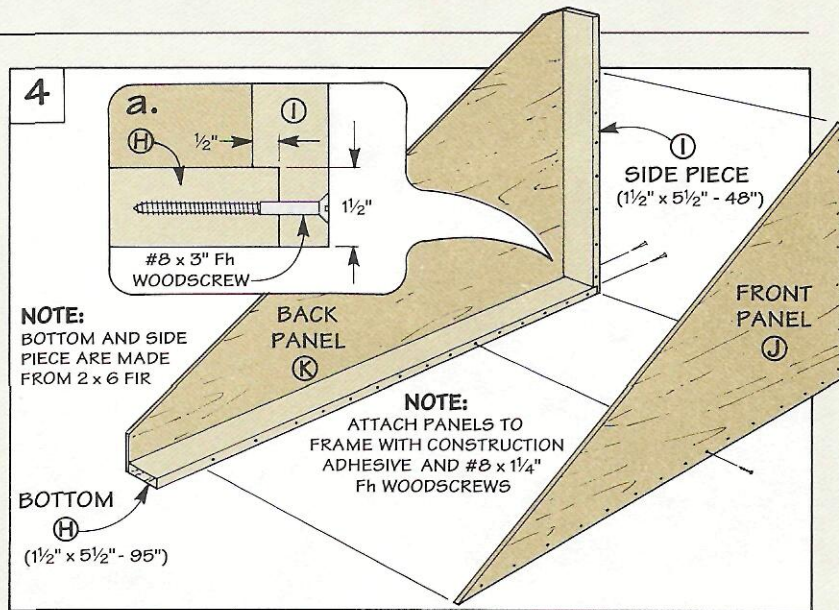

rides on a pair of fixed casters, see Fig. 6. And the closed end is attached to the lumber rack with two T-hinges, see Fig. 6a. I found it easiest to support the hinged end with a temporary spacer cut to match the height of the casters

when screwing the hinges in place.

**LOAD BIN.** Now it's just a matter of loading up the bin. Since the pieces are stored on edge, the bin is easy to pull out when you need one. Just grab one of the pieces and use it as a "handle."

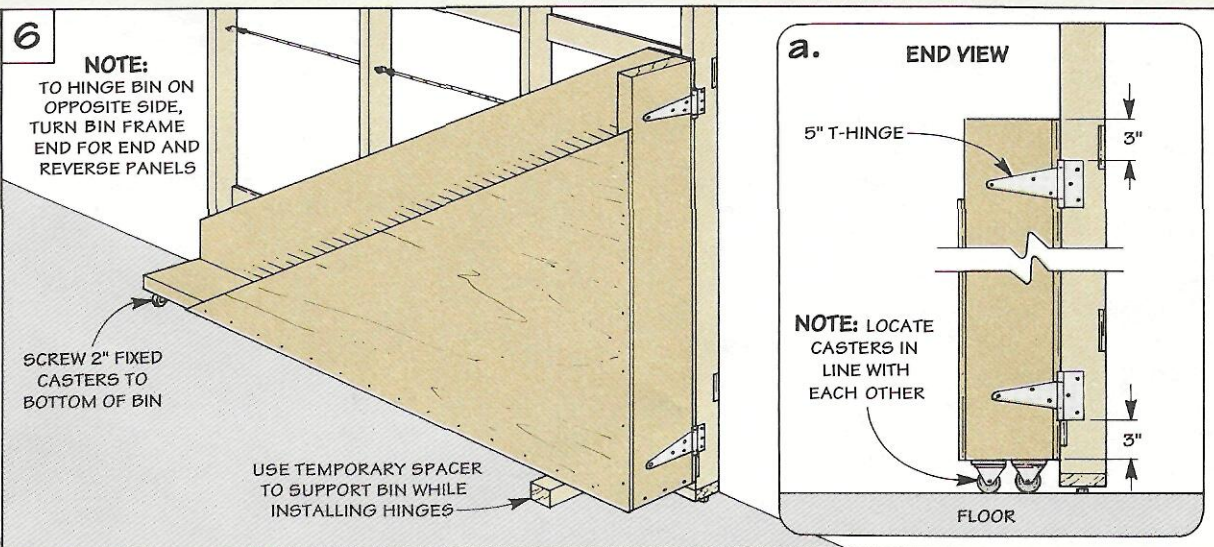

# Containing Noise in the Shop

*It's easy to deal with chips and sawdust. But how do you handle the noise your shop produces?*



**W**henever I work in my shop, dealing with noise isn't a problem for me. I've taken the time to reduce the noise my tools produce. (For more on this, see *ShopNotes* No. 16.) And I always wear hearing protection. But for the members of my family and my neighbors, the noise is a problem.

To make the noise more bearable for everyone, I decided to take a look at what could be done about reducing the amount of noise *leaving* my shop. What I discovered was quite interesting.

**FREQUENCY.** First, every sound has a specific pitch or frequency. And each tool produces a different frequency. Second, different materials for ceilings and walls (and how they're configured) block some frequencies better than others, see graph below.

This means that no one material can block every sound. The challenge is selecting the best *combination* of materials to block the most noise.

Fortunately, acoustical engineers have already studied this problem and can offer some help.

**STC.** Over the years, they've tested just about every type of ceiling and wall imaginable to see how they block sound. Ceilings and walls made of drywall, concrete, wood, and lead. With insulation, without insulation.

First, they bombard each ceiling and wall with noise made up of different frequencies at different intensities. Some frequencies penetrate more than others. The amount of sound that passes is then measured and recorded.

After some mathematical wizardry, they end up with a rating that's referred to as the wall's Sound Transmission Class (STC). As a general rule, the higher the rating, the more noise a ceiling or wall blocks (keeping in mind that certain frequencies can pass through a wall even with a high STC).

For instance, a 2x4 stud wall with 5/8" drywall on both sides has an STC of 35 (add three points if it's filled with fiberglass insulation). A drywall ceiling with carpet on the floor above is rated around 37.

**IN THE SHOP.** These are fine for normal household noise. But you'll need a higher STC to reduce shop noise to a reasonable level. Typically you should strive for an STC of at least 50 to 55 (the higher the better). The nice thing is this can be done with commonly available building materials.

Keep in mind though, your shop won't be totally soundproof. But your family and neighbors should be able to watch TV again without having to constantly raise or lower the volume each time a tool is turned on or off.

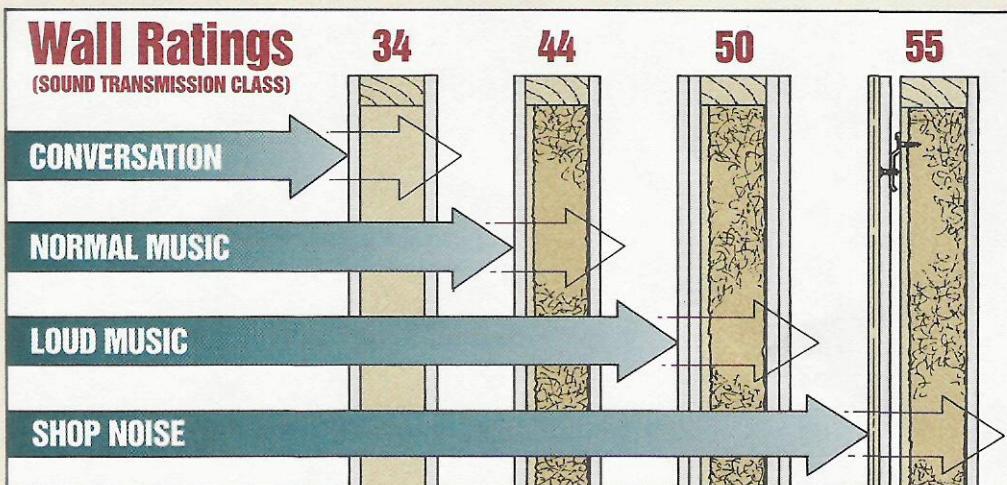

# Openings

## DOORS

One of the most important things you can do to contain noise is to have a tightly sealed entry door (and overhead door if your shop is in the garage), see photos at right.

Also, if your shop door has a hollow core (STC 17), it's a good idea to replace it with one that has a solid core (STC 28). Then add a threshold (or door sweep) to the bottom. And seal around the edges with weather stripping.

Note: If your door jamb is wide enough, you can create a double-door airlock (STC 56) by installing two sealed doors in the opening.



▲ **Entry Doors.** To help sound-proof a door, install a threshold (or door sweep) and apply weather stripping to the edges.

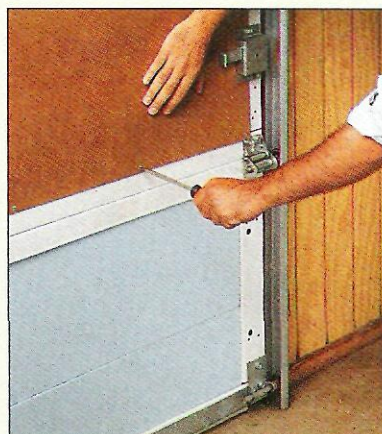

▲ **Overhead Doors.** You can increase the STC of a garage door by filling the panels with insulation and covering it with Masonite.

## WINDOWS

An inexpensive way to reduce the noise that passes through a closed window is with glazing and weather stripping, see photos at right. (If money isn't a concern, you can replace your old windows with double-insulated windows or add storm windows.)

Then to help break up and dissipate the noise before it passes through the glass, cover the window with shades or curtains. These won't stop the noise completely, but they will muffle it so it's not as loud.

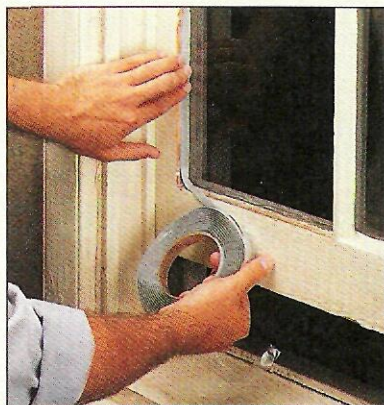

▲ **Repair Windows.** To seal windows for noise, first replace any broken glass and repair cracked or missing window glazing.

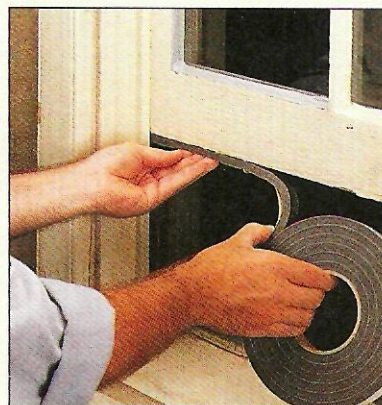

▲ **Seal Windows.** To reduce the amount of noise passing through a window, install weather stripping around the edges of the window.

## ELECTRICAL BOXES

In addition to the doors and windows in your shop, the electrical boxes may need some attention. If you're planning on installing the wall treatment described on page 24, you'll need to extend the boxes out so they end up flush with the wall, see photos at right.

Also, just like heat in your shop, noise will find its way out the smallest opening. That's why it's important to caulk the gaps between the electrical boxes and the finished wall before installing the outlet and switch covers.

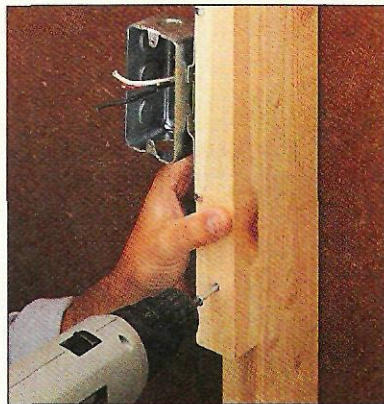

▲ **Stud Extension.** Extend electrical fixtures so they're flush with your new wall by widening studs with scrap "two-by" material.



▲ **Box Extension.** An easier way to extend electrical boxes is with extensions. They're available at most home centers.

# Ceilings & Walls

When looking into ways to quiet a shop, I found there were many choices. What I settled on was a design that was the most practical for the money — and used commonly available building materials. It provides a ceiling or a wall with an STC rating around 55, see Figs. 1 and 2.

**FIXTURES.** The first step was to determine how much thickness this would add to a ceiling or wall. For this design, it's 1½" (but it may vary depending on your materials). Then in order for the electrical boxes to end up flush with the wall, each box is extended this same distance, see Step 1 below and Electrical Boxes on page 23.

**SOUND BLANKET.** One of the simplest ways to increase the STC of an existing wall is to add a *sound blanket*, see Step 2.

The sound blanket that I use (Therma Fiber — United States Gypsum Company) is very similar to the mineral wool used years ago to insulate ceilings and walls.

Filling a stud wall with a 3"-thick sound blanket increases the STC to 44. And it insulates almost

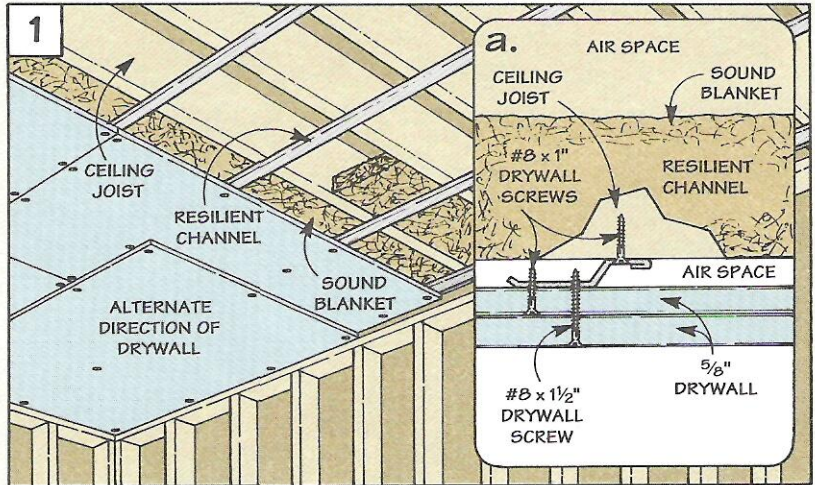

as well as a 3½"-thick blanket of fiberglass insulation — at about the same cost. (Note: Since sound blanket doesn't have a vapor barrier, you'll need to install one on your exterior ceilings and walls.)

When installing a sound blanket, more is not necessarily better. You don't want to stuff the space between the joists or studs. Pockets of air within a ceiling or wall help deflect and break up sound. That's why sound blanket isn't as thick as 3½" fiberglass insulation, refer to Fig. 2a.

**RESILIENT CHANNEL.** Next, to bring the STC of a ceiling or wall up to around 50, I add *resilient channel* in between the studs (or joists) and the drywall, see Figs. 1 and 2 and Steps 3 and 4 below. (Resilient channel is an S-shaped length of galvanized steel.)

When sound waves hit the drywall, the resilient channel allows the ceiling and wall to work like a large, flat shock absorber. As the sound waves strike the drywall, the channel absorbs the shock. (When drywall is screwed directly

## Containing Noise: Step-By-Step

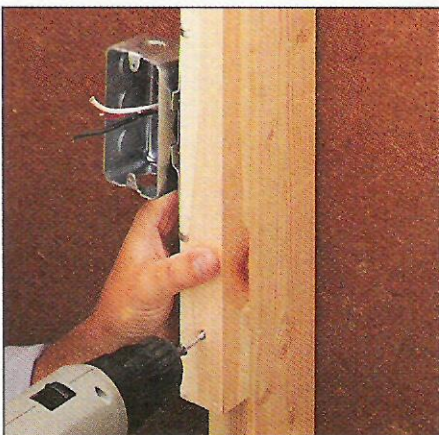

**Step 1.** Before you begin work on the ceiling or walls, you'll need to extend all of your electrical boxes.

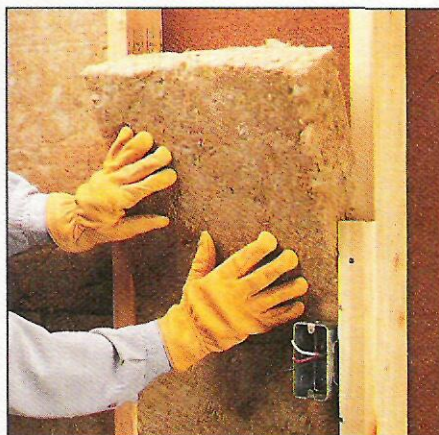

**Step 2.** A quick and inexpensive way to increase the STC of a wall is to tuck a sound blanket between the studs.

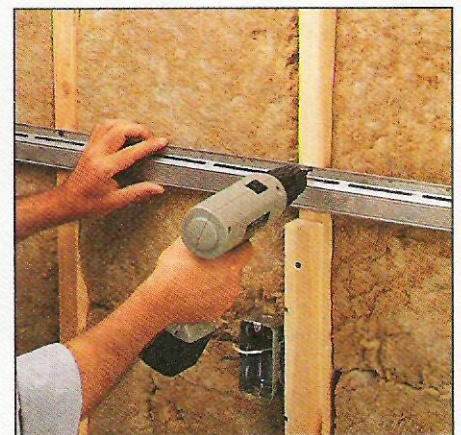

**Step 3.** With the sound blanket in place, screw lengths of resilient channel to the studs or joists.



to the joists or studs, sound waves vibrate through the studs to the wall on the other side.)

The resilient channel I use (RC-1) is manufactured by Unimast Incorporated for United States Gypsum Company. It's 2½" wide and comes pre-drilled with holes for drywall screws. It costs around \$1.75 for a 12-foot length and is available from most commercial drywall suppliers.

**TWO LAYERS.** Next, to increase the STC even further (55), all you have to do is add a second layer (drywall or paneling), see Step 5.

**NOISE INTENSITY.** The only problem with drywall and resilient channel is it can do *too* good a job. It stops so much sound that you may find the noise level *inside* the shop increases.

That's because drywall creates a smooth, flat surface that allows sound waves to bounce around a number of times before they're absorbed or muffled.

Fortunately, there are a number of ways to reduce the noise intensity. The simplest is to fill the shop with tools and storage cabinets. But to muffle the noise

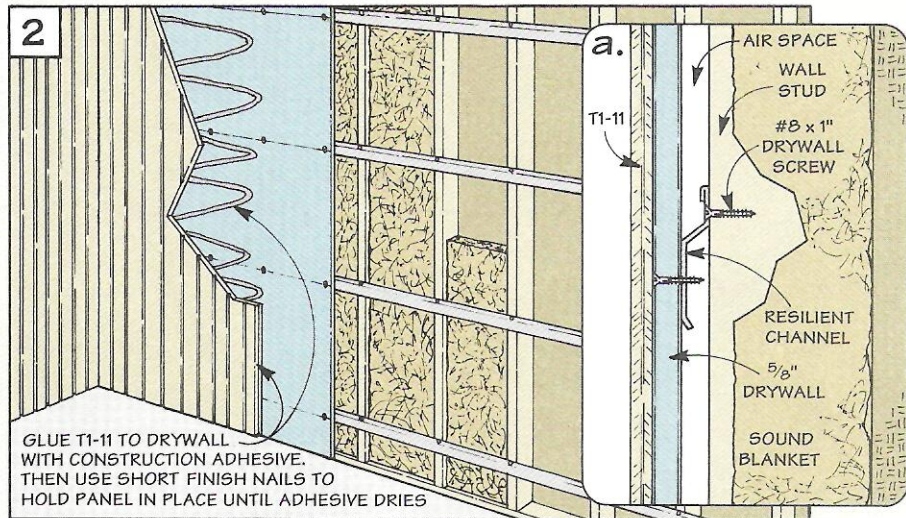

even more, I like to add a layer of textured wood paneling (such as T1-11 exterior siding) to the walls, see Step 5 and Fig. 2.

T1-11 (available in ¾" and 5/8"-thicknesses) has vertical grooves in it to help break up the sound. And because it's wood, it holds screws much better than drywall. This makes it ideal for mounting tool racks and shelving.

**MOVE FREELY.** There are two things you'll need to keep in mind when working with the drywall and T1-11. First, to allow the ceil-

ing and walls to move independently (and provide the shock absorber action) they can't touch the floor, ceiling, and boxes. So leave about an 1/8" gap. Then to prevent noise from leaking to the outside, seal these gaps with a flexible silicone caulk, see Step 6.

And second, you can't nail trim or molding to the studs as you would normally. So instead, glue it in place with construction adhesive. Shop Tip: To keep trim in place while the adhesive dries, tack it on with short finish nails.

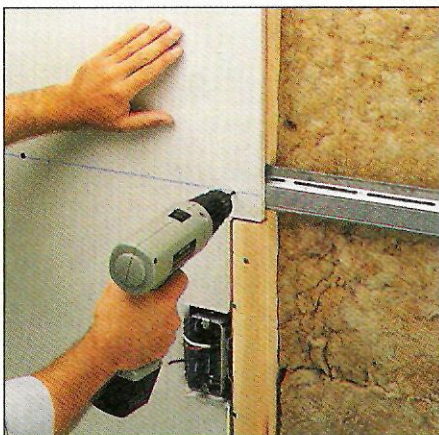

**Step 4.** Now you can screw a layer of drywall to the resilient channel. Use short screws so they don't hit the studs.

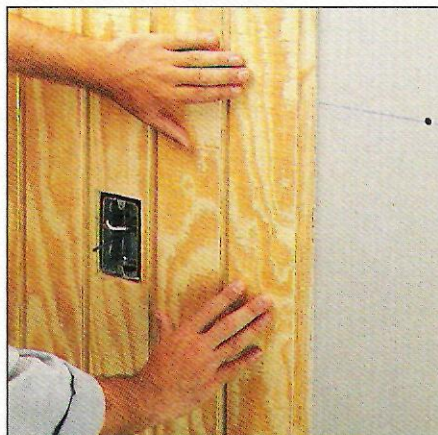

**Step 5.** A second layer (either drywall or T1-11) will help further increase the STC of the wall and block noise.

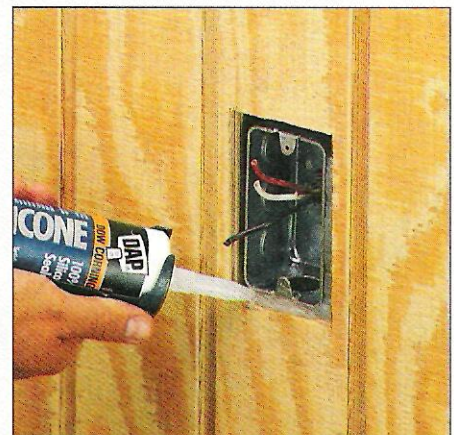

**Step 6.** To seal noise in, and still allow the walls to flex, fill in any gaps with a high-quality silicone caulk.

# Band Clamp

*A simple design makes this shop-built band clamp as easy to build as it is to use.*

**H**ere's an inexpensive band clamp that you can make in an hour or two. But don't let that fool you. It's a heavy-duty clamp that applies even pressure on large projects, see photo. And its unique design allows you to clamp small projects as well, see inset photo.

## BODY

The wood body of the clamp houses the clamp mechanism, see Exploded View. And its V-shaped jaws help position the clamp on the corner of a workpiece.

**SIDES.** The body starts out as a hardwood *top* and *bottom* (A), see

Fig. 1. Each piece has three holes in it. To ensure all these holes align, I carpet-taped the top and bottom together before drilling the holes.

Two of the holes are sized to fit a pair of dowels (added later). And a large hole creates a curved opening at the corner of the jaws. This keeps all the stress from concentrating at one point when the clamp is tightened. And it serves as a "relief" for glue squeeze-out.

**JAWS.** After drilling the holes, you can cut the jaws. What I found worked best is to tilt the blade on the table saw to 45° and

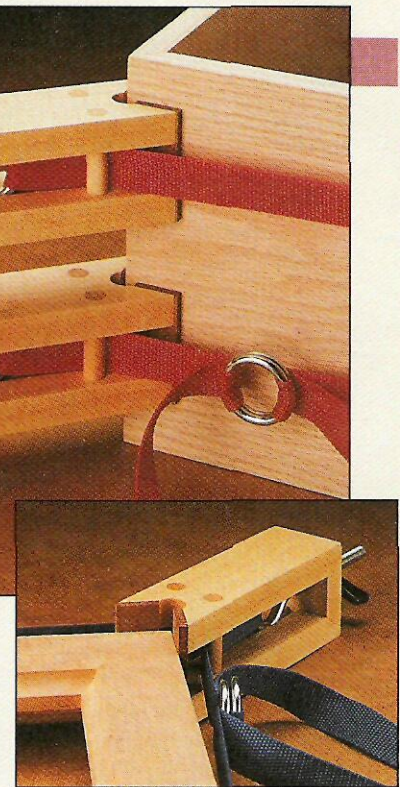

make two passes, see Fig. 1a. **GROOVES.** To provide a "track" for an eye bolt that's part of the clamp mechanism, the next step is to cut a groove in the top and bottom, see Fig. 2 and Detail 'a' in Exploded View. And there's a rabbet on one end of each piece to accept an end piece, see Detail 'b.'

**END PIECE.** The *end piece* (B) is just a block of 3/4"-thick hard-

## EXPLODED VIEW

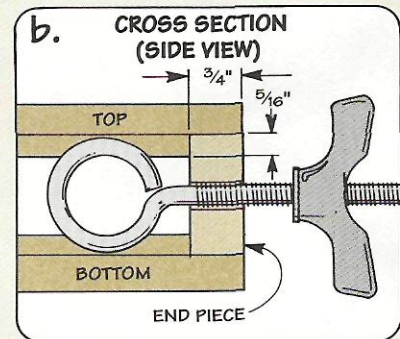
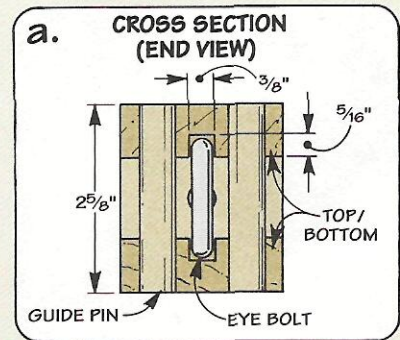
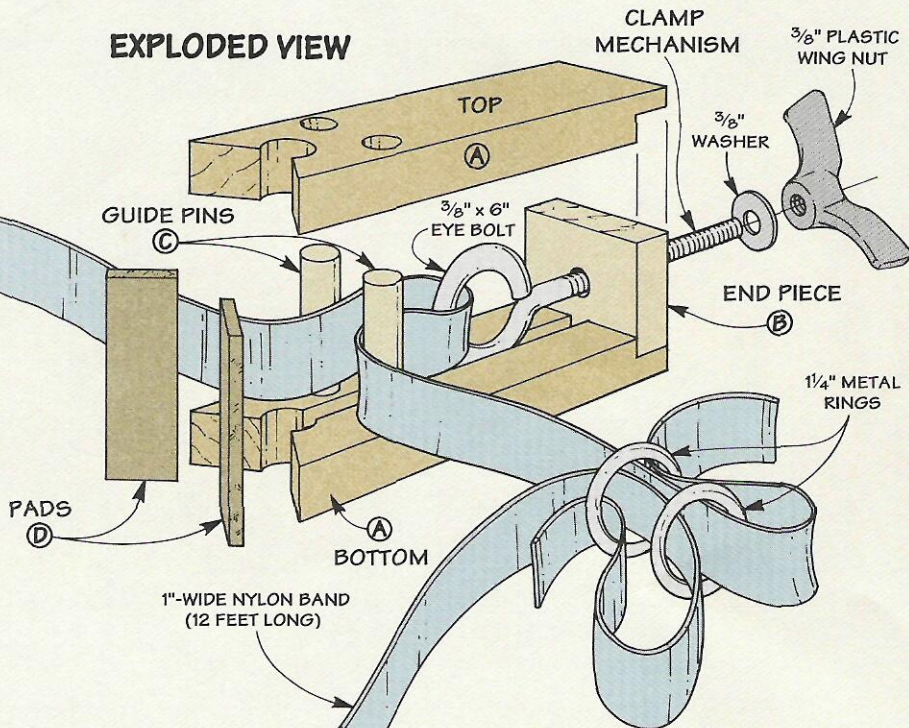

wood with a centered hole drilled in it to accept the eye bolt (added later), see Fig. 2. But before gluing the end piece in place, there's one more thing to do.

**GUIDE PINS.** To allow the band to cinch up tight, I added two *guide pins* (C), see Fig. 2. These pins are short hardwood dowels that fit in the holes drilled earlier in the top and bottom pieces.

When installing the guide pins, it's easiest to glue them into the bottom first, see Fig. 2. Then just glue the end piece (B) and the top in place so the ends of the pins are flush.

**PADS.** To keep small projects from slipping through the opening between the jaws, I added a pair of *pads* (D), see Figs. 3 and 3a. These are just strips of 1/4"-thick Masonite that are glued onto the jaws.

**CLAMP MECHANISM**

Now all that's left to complete the band clamp is to install the clamp mechanism. The key to this mechanism is an eye bolt that's inserted through the jaws of the clamp. Here's how it works.

The shank of the bolt passes through the hole in the end piece (B), refer to Exploded View. And the "eye" rides in the grooves. When you slip on a washer and tighten a plastic wing nut against the end piece, it draws the bolt back and applies tension to the band. (For a complete hardware kit, see page 31.)

**BAND.** To make this work, the nylon band slips through the eye of the bolt and around the guide pins. The ends of the band are woven through a pair of metal rings, see Exploded View.

These rings work like a buckle. They hold the band tight when you apply pressure, or loosen it when the clamp is adjusted for different size projects. (For more on using the band clamp, see photos at right.)

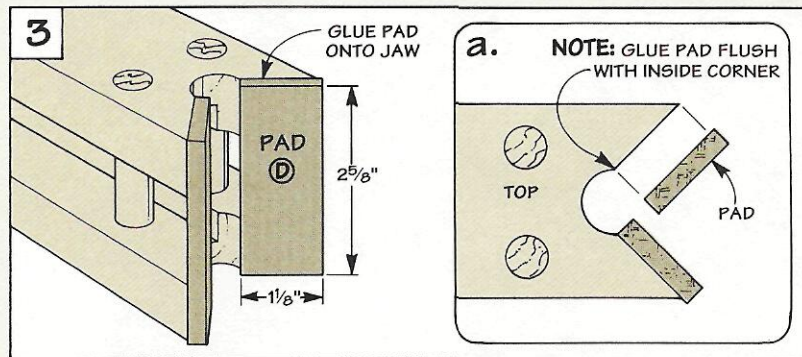
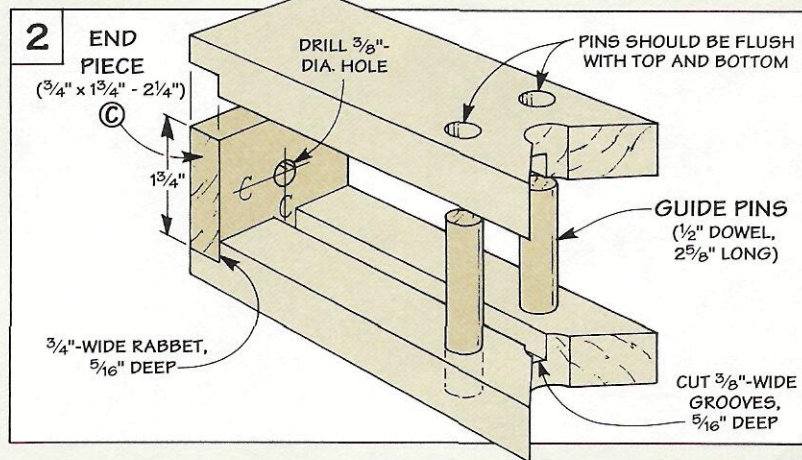
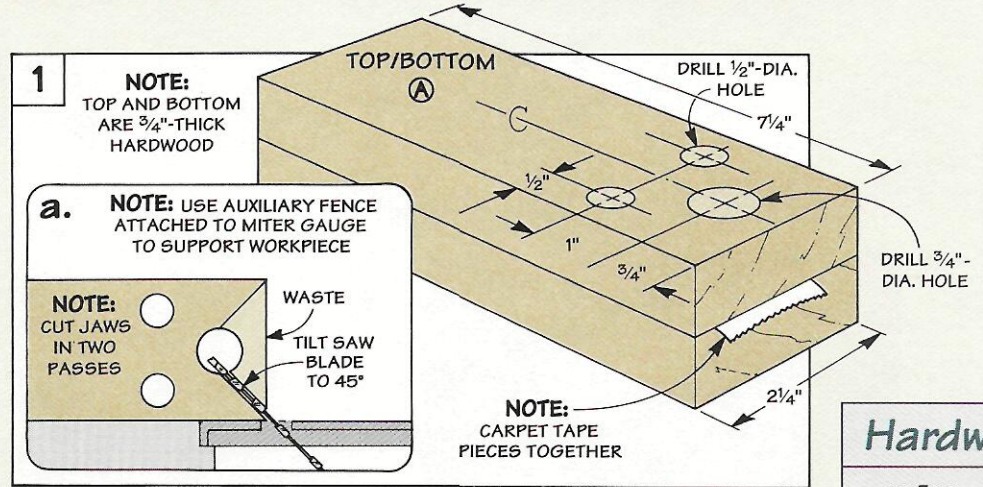

- Hardware**
- (1) 3/8" x 6" Eye Bolt
  - (1) 3/8" Washer
  - (1) 3/8" Plastic Wing Nut
  - (1) 1"-Wide Nylon Band - (12 feet)
  - (2) 1/4"-Dia. Metal Rings



▲ With the wing nut on the clamp backed off all the way, slip the band around the project and tug the ends to remove the slack.

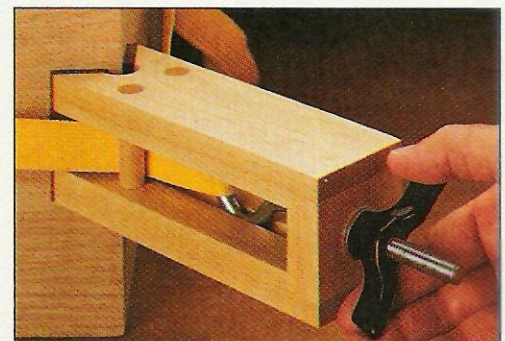

▲ Now fit the jaws of the clamp on a corner of the project, reposition the strap (if necessary), and tighten the wing nut.

# Shop Solutions

## Roll-Out Storage

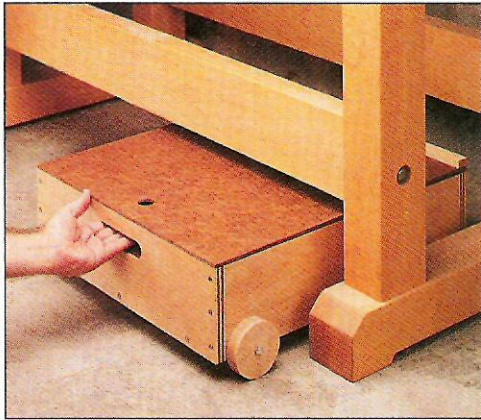

■ I never seem to have enough storage in my shop. So I try to take advantage of any available space I can find. Recently I realized there was space *under* my workbench that I could use.

The only problem with storing anything under the bench is it can be difficult to get to. My solution is to add wheels to a shop-made drawer. This way, it slides out easily when you need something.

**CONSTRUCTION.** The drawer is a plywood box held together

**NOTE:** GLUE CLEAT TO LID FOR SCREW SUPPORT

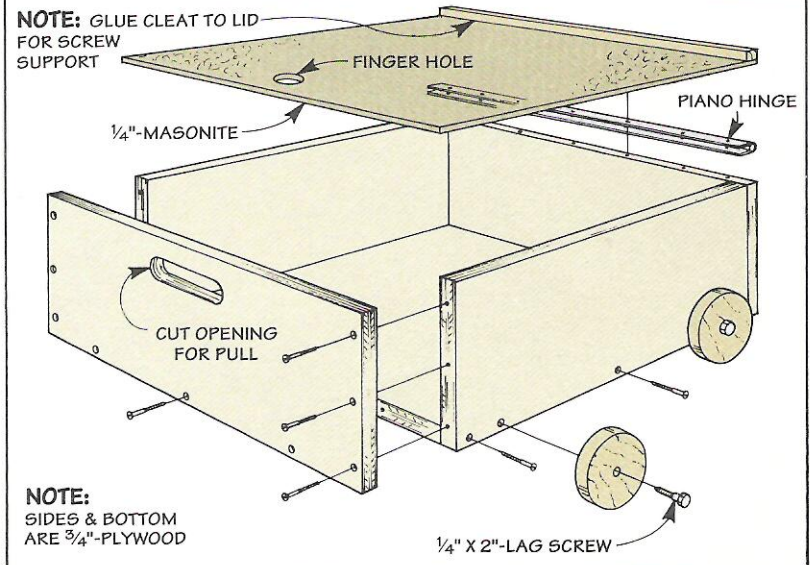

**NOTE:** SIDES & BOTTOM ARE 3/4\"/>

with glue and screws, see Drawing. To keep out dirt and dust, there's a 1/4"-thick Masonite top that's hinged at one end. Note: A cleat glued to the top gives the screws something to grab.

There's an opening cut in the front of the drawer to serve as a pull. And a finger-sized hole in

the top so you can lift up the lid.

**WHEELS.** For wheels, you can use just about any size or type. I cut mine out with a hole saw. It makes a nice round circle. And the 1/4"-dia. hole left in the center is perfect for a 1/4" lag screw.

*Michael Hoag  
Endicott, New York*

## Disk Sander Stop System

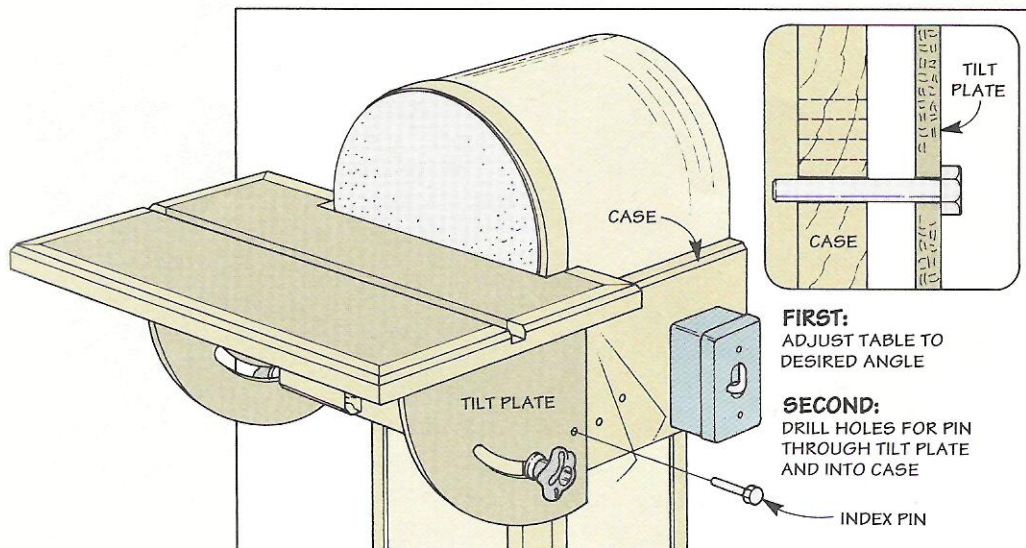

■ The disk sander featured in *ShopNotes* No. 12 works great. But since I do a lot of sanding with the table at different angles, I added a stop system that lets me automatically set the angle.

This stop system uses an index pin and a series of holes. The pin is a 1/4"-diameter bolt with the threads cut off. And the holes are drilled through one tilt plate and into the sander case, see Drawing.

Now I can quickly and accurately change the table angle.

*Bob Nicoll  
Ramona, California*

## Clamping Squares

■ Recently, I was assembling a large bookcase by myself. But I didn't have enough hands to keep everything square while I glued and screwed it together.

Instead of calling a neighbor for help, I made several plywood "clamping squares" that resemble a framing square, see Drawing. Note: Make sure the outside corner of each square is 90°.

When clamped in place, they square up the cabinet and hold the pieces in position.

*Norman Smith  
Gaithersburg, Maryland*

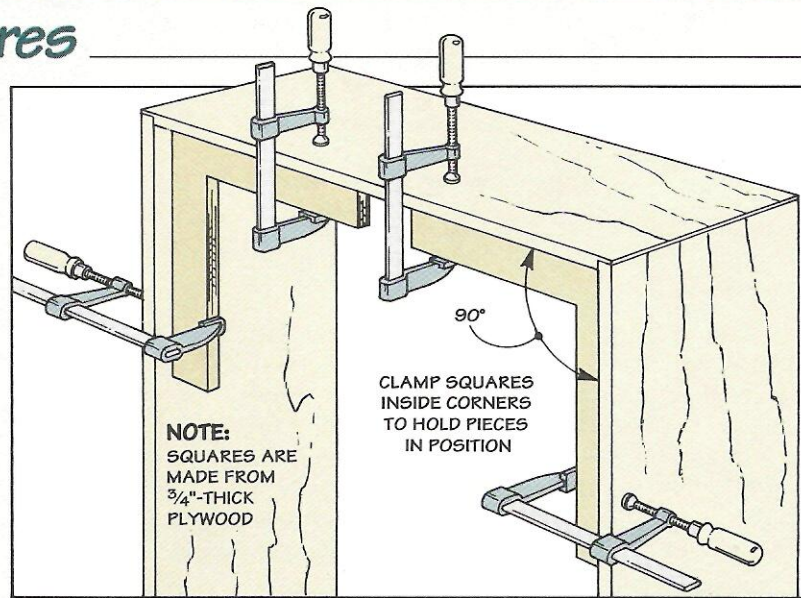

## Auxiliary Table Saw Fence

■ Crosscutting a large workpiece on a table saw can be a problem. It always seems that the rip fence won't move over far enough to make the cut. Or the runner on the miter gauge doesn't reach the slot to start the cut.

My solution is simple. All I do is attach an auxiliary fence to the workpiece, see Drawing. The fence is just a piece of angle iron I picked up at the hardware store.

The secret is to clamp it to the bottom of the workpiece so it rides along the extension wing of the table saw. This way, it guides the workpiece as you make a cut.

*Vic Bell  
Chenoa, Illinois*

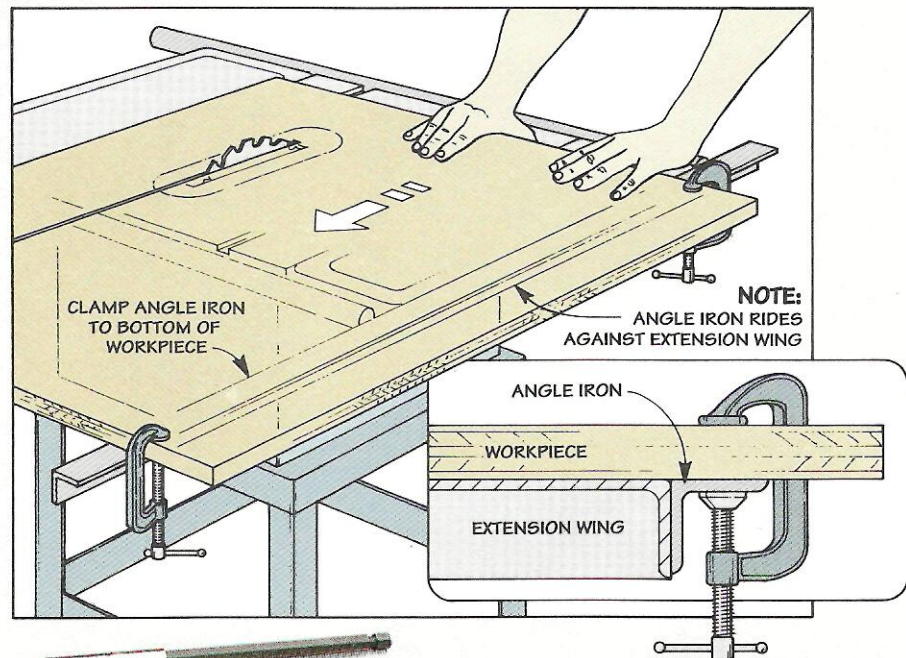

## Quick Tips

■ I repair many of my projects with small amounts of epoxy. To prevent waste, I mix batches in a plastic spoon. The spoon's shape makes mixing a snap — everything runs together. And it's easy to pour the mixture out where it's needed. When I'm finished, I just throw the spoon away.

*Edwin Wurster  
Buffalo, New York*

■ I often use a screwdriver bit in my drill to assemble projects. But sometimes there isn't enough clearance for the drill. To solve this, I extend my short drive bits with an inexpensive drill bit extension, see photo above. They come in various lengths and are available at most hardware stores.

*C.A. Hazelwood  
Leitchfield, Kentucky*

## Send in Your Solutions

If you'd like to share your original solutions to problems you've faced, send them to: *ShopNotes*, Attn: Shop Solutions, 2200 Grand Avenue, Des Moines, IA 50312. (Or if it's easier, FAX them to us at: 515-282-6741.)

We'll pay up to \$200 depending on the published length. Please include a daytime phone number so we can call you if we have questions.

# Aniline Dyes

What's the difference between an "off the shelf" stain from the hardware store and the aniline dyes I've seen in woodworking catalogs?

Kris Robinson  
Spicer, Minnesota

*Aniline dyes produce clear, bright colors to show off the figure of wood.*

■ The biggest difference is the color. Many stains look "muddy"—like looking through a window with the screen on. Remove the screen, and you get an idea of the clear colors produced by aniline dyes.

The reason is simple. Most stains leave tiny colored particles (pigments) on the surface of the wood. But dyes penetrate the wood fibers. This emphasizes the figure of the wood instead of partially obscuring it, see left-hand photo below.

**EVEN COLOR.** Aniline dyes also color the wood more *evenly* than pigmented stains. Unlike pigments that concentrate in the areas of the wood that have large pores (like end grain), dyes penetrate all parts equally.

**RANGE OF COLORS.** Another thing I like about aniline dyes is

the wide range of colors. There are even bright, primary colors for kids' projects, see the right-hand photo below. (See page 31 for sources.)

**POWDER.** Regardless of the color, most dyes are sold as a dry powder that needs to be dissolved in a solvent. Basically, there are three types of solvents: water, alcohol, and oil.

**WATER-SOLUBLE.** Of the three, I've found that the water-soluble

the dye. This raises "whiskers" that are easy to remove with sandpaper. (I use one grit finer than the final one used to sand the project.)

**MIXING.** When mixing the dye, dissolve the powder in hot water like you're making a cup of instant coffee. Although the recommended ratio is one ounce of dye powder to a quart of water, you can create a lighter (or darker) color by using more (or less) water.

Mixing your own dye may sound like a hassle, but that's not the case. What it does is give you more control to get the exact color you're looking for.

**MATCHING COLORS.** For example, recently I was trying to match the color of a piece of molding. To "work up" to the color I wanted, I simply added small amounts of other colors (keeping track of the ingredients so I could duplicate the color). Note: It's a good idea to use a sample board to test the color, see photo above.

**APPLICATION.** As with most stains, you can use a rag or brush to apply the dye. To avoid lap marks, the trick is to keep the surface wet and wipe off the excess dye before it dries.

**A FINAL NOTE.** Be aware the dye will *appear* chalky or dull when it dries. But applying a finish is all it takes to restore a clear, bright color, see center photo. Just be sure to use an oil-based finish since water will redissolve the dye.



dyes are the easiest to apply. And they produce deep, rich colors that aren't as likely to fade. But they do have one drawback.

**GRAIN-RAISING.** The water in the dye raises the grain of the wood and produces a rough surface. Since sanding the wood *after* it dries removes some of the color, I wipe down the project with a damp rag *before* applying

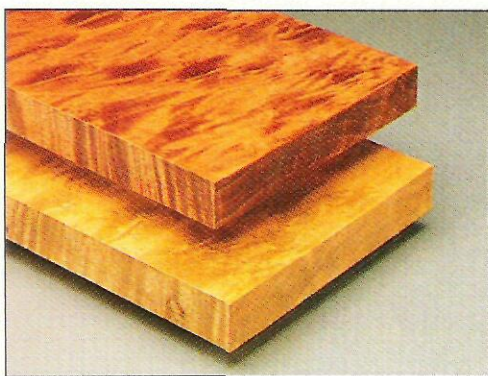

**Clear Colors.** The transparent color of aniline dyes (above) is ideal for highly figured wood that's hidden by pigment stains (below).

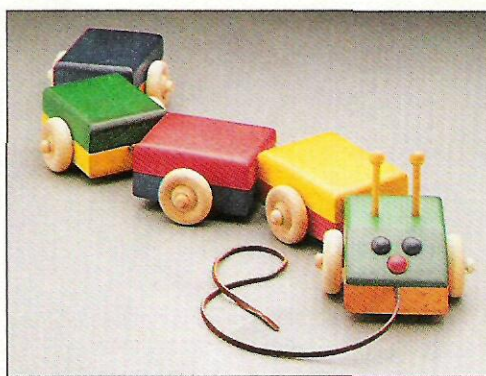

**Toy Dyes.** Special aniline dyes are also available in bright colors that are safe to use on children's toys and furniture.

# Sources

*ShopNotes Project Supplies* is offering some of the hardware and supplies needed for the projects in this issue. We've also put together a list of other mail order sources that have the same or similar hardware and supplies.

## ADJUSTABLE SAWHORSE

The Adjustable Sawhorse shown on page 4 is not your ordinary sawhorse. It adjusts up and down, so you can use it to support long or awkward workpieces — even if the tables on your power tools are at different heights. And when it's not in use, the sawhorse knocks down for easy storage.

*ShopNotes Project Supplies* is offering a complete hardware kit for the Adjustable Sawhorse. All you need to supply is the wood to build the project.

**S17-6817-100** Adjustable Sawhorse Kit .....\$4.95

## LUMBER STORAGE RACK

To store and organize all of your lumber and sheet goods in one convenient place, you can build the Lumber Storage Rack shown on page 16. This sturdy rack supports several rows of black iron pipe that provide storage for

long boards and short cutoffs. And there's an optional bin that can be added for storing full or partial sheets of plywood.

*ShopNotes Project Supplies* is offering a hardware kit for the Lumber Storage Rack. Except for the black iron pipe (which is available at most hardware stores), this kit has all the hardware you'll need to build the lumber storage rack. It also includes the stretch cords for the storage compartments at the bottom of the rack.

**S17-6817-200** Lumber Storage Rack Kit..... \$17.95

## CONTAINING NOISE

The article on page 22 provides tips and techniques for containing noise in the shop. To prevent noise from escaping, there's a complete ceiling and wall system that traps it inside the shop where it belongs.

To keep noise from being transmitted through ceilings and walls, there are two special products: 'S-shaped' resilient channel and a sound "blanket." You'll find both of these products at most drywall supply stores.

The other products that are used to contain noise (like T1-11 siding, and foam board) can be

found at most lumberyards and home centers.

## BAND CLAMP

A few pieces of hardware and some scraps of wood are all it takes to build the Band Clamp shown on page 26. This clamp is ideal for applying pressure either on large or irregular-shaped projects.

*ShopNotes Project Supplies* is offering a hardware kit for the Band Clamp. Along with a 12-foot length of nylon band (blue), it includes all the hardware you'll need to build *one* clamp.

**S17-6817-300** Band Clamp Hardware Kit.....\$9.95

## ANILINE DYES

The article on the opposite page takes a close look at aniline dyes. These dyes come in a powdered form which is mixed with a solvent (we use water-soluble dyes) to produce bright, clear colors.

Aniline dyes are available at some woodworking stores and in many woodworking catalogs. And they come in a wide range of colors. There are even special non-toxic dyes for use on kids' toys and furniture, see the mail order sources below.

## MAIL ORDER SOURCES

*Similar hardware and supplies may be found in the following catalogs. Please call each company for a catalog or for ordering information.*

<b>Constantine's</b> 800-223-8087 <i>Aniline Dyes, Finishing Supplies</i>	<b>Highland Hardware</b> 800-241-6748 <i>Aniline Dyes, Toy Dyes, Finishing Supplies</i>	<b>Woodcraft</b> 800-225-1153 <i>Aniline Dyes, Finishing Supplies, Plastic Knobs</i>
<b>Garrett Wade</b> 800-221-2942 <i>Aniline Dyes, Finishing Supplies</i>	<b>McFeely's</b> 800-443-7937 <i>Aniline Dyes</i>	<b>The Woodworkers' Store</b> 800-279-4441 <i>Plastic Knobs</i>
<b>Hartville Tool &amp; Supply</b> 1-800-345-2396 <i>Plastic Knobs</i>	<b>Trendlines</b> 800-767-9999 <i>Plastic Knobs</i>	<b>Woodworker's Supply</b> 800-645-9292 <i>Aniline Dyes, Finishing Supplies, Plastic Knobs</i>

## ORDER INFORMATION

### BY MAIL

To order by mail, use the order form that comes with the current issue. The order form includes information on handling and shipping charges, and sales tax.

If the mail order form is not available, please call the toll free number at the right for more information on specific charges and any applicable sales tax.

### BY PHONE

For fastest service use our toll free order line. Open Monday through Friday, 7:00 AM to 7:00 PM Central Time.

Before calling, please have your VISA, MasterCard, or Discover Card ready.

**1-800-444-7527**

*Note: Prices subject to change after November 1, 1994.*

## Scenes From the Shop

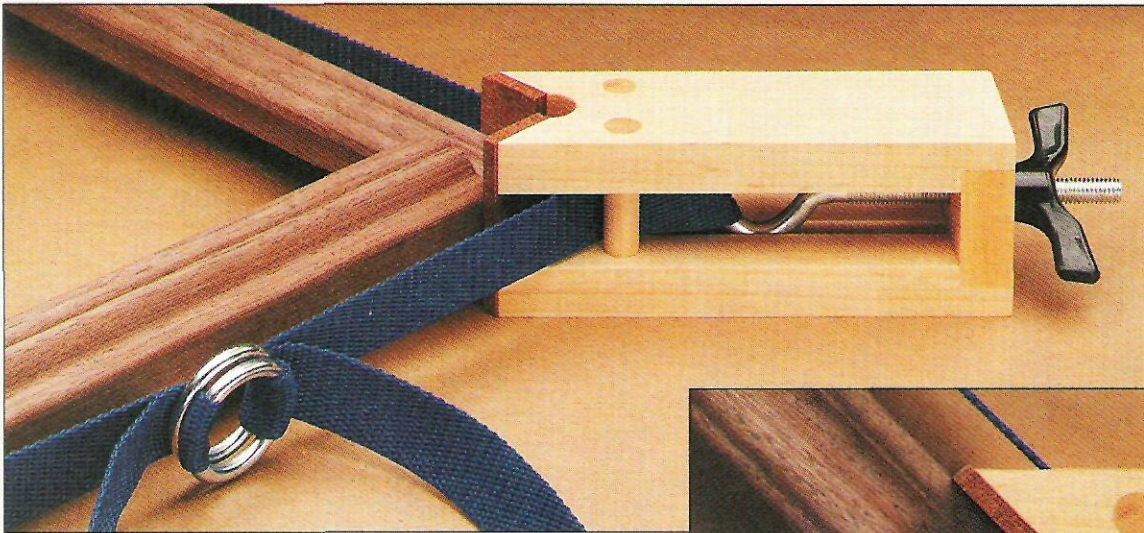

### Band Clamp

After fitting this wood-bodied Band Clamp (page 26) on the corner of a project, a wing nut is tightened to apply even pressure on a nylon band. A metal buckle makes the band fully adjustable. And there's a circular opening in the jaws that prevents crushing the corner of the project.

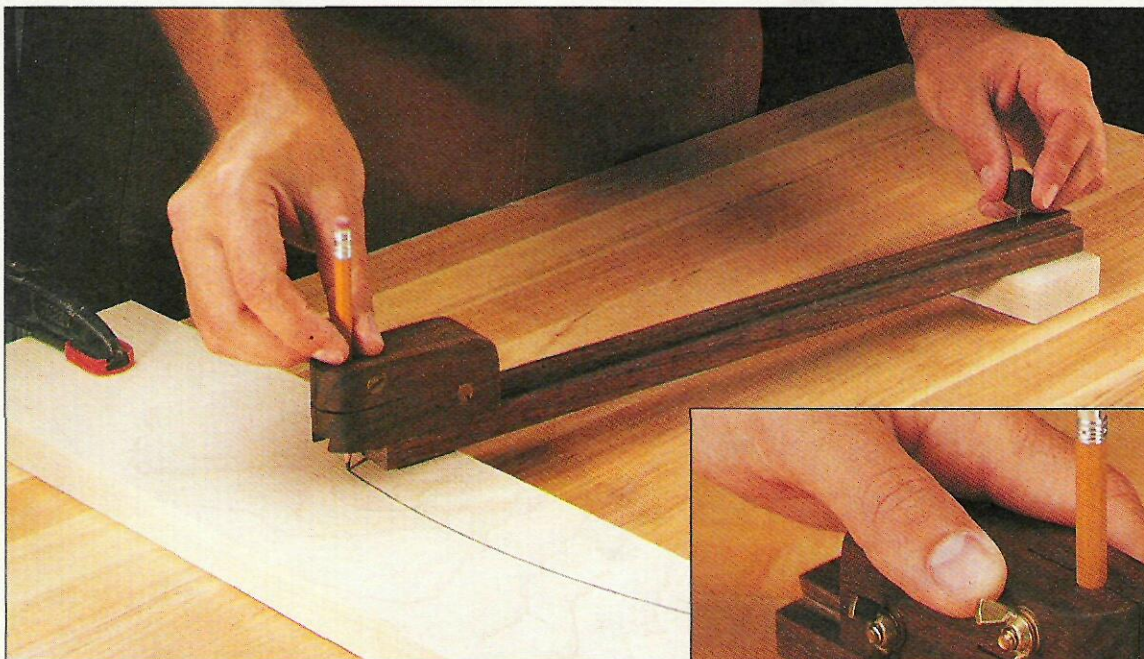
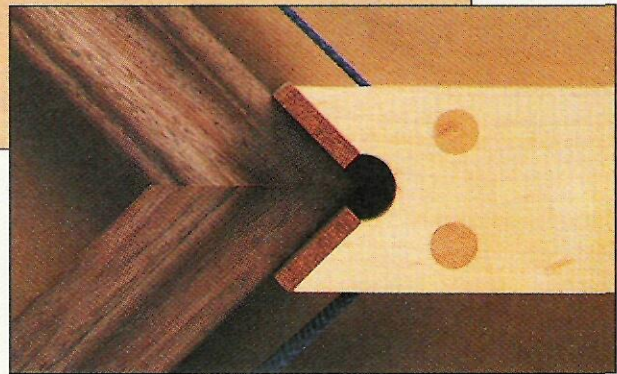

### Combination Layout Tool

With a pivot pin holding one end of a long beam in place and a head that holds an ordinary pencil, the Combination Layout Tool (page 12) serves as a beam compass. To convert it into a marking gauge for laying out a joint, replace the beam with a short stop (shown at right).

