

T I P S • T O O L S • T E C H N I Q U E S

# ShopNotes®

Vol. 3

Issue 18



Micro-Adjustable  
**DRILL PRESS  
TABLE &  
FENCE**

- Hand-Cut Dovetails
- Resawing on the Band Saw
- Hardware Storage Bin
- Exclusive Drawer Joint Jig

**EDITOR** Donald B. Peschke  
**EXECUTIVE EDITOR** Douglas L. Hicks  
**MANAGING EDITOR** Richard S. Peters  
**ASSOCIATE EDITOR** Tim Robertson  
**ASSISTANT EDITOR** Phil Totten  
**CONTRIBUTING EDITOR** Mark A. Williams

**CREATIVE DIRECTOR** Ted Kralicek  
**ART DIRECTOR** Cary Christensen  
**SENIOR ILLUSTRATOR** Kurt Schultz  
**ILLUSTRATORS** Will Niskanen  
 Roger Reiland  
 Mark Higdon  
**PHOTOGRAPHER** Crayola England

**DESIGN DIRECTOR** Ken Munkel  
**SENIOR DESIGNER** Kent Welsh  
**SHOP MANAGER** Steve Curtis  
**SHOP ASST./FACILITIES** Steve Johnson

**CIRCULATION**

*Circulation Director:* Liz Bredeson ▪ *Subscription Manager:* Phyllis Jessen ▪ *Newsstand Sales:* Kent A. Buckton

**PUBLISHING SERVICES**

*Manager:* Gordon C. Gaippe ▪ *Graphic Artist:* Cheryl L. Cynor

**CORPORATE SERVICES**

*Controller:* Robin Hutchinson ▪ *Accounting:* Laura Thomas ▪ *Bookkeeping:* Julie Greenlee ▪ *Production Manager:* Carol Quijano ▪ *Info. Services Manager:* Joyce Moore ▪ *Elect. Pub. Coordinator:* Douglas M. Lidster ▪ *Application Specialist:* Linda Morrow ▪ *Support Assistant:* Nick Thielen ▪ *Admin. Assistants:* Cheryl Scott, Julia Fish ▪ *Recept.:* Jeanne Johnson ▪ *Building Maintenance:* Ken Griffith

**PROJECT SUPPLIES**

*Marketing Director:* Robert Murry ▪ *Art Director:* Cindy Jackson ▪ *Catalog Products Manager:* Bob Baker ▪ *Inventory Control/Prod. Manager:* Mark Mattussi ▪ *Project Supplies:* Linda Jones ▪ *Technical Support:* Jeff Janes ▪ *Receptionist:* Cynthia Kerman

**CUSTOMER SERVICE**

*Supervisor:* Jennie Enos ▪ *Customer Service Reps.:* Jennifer Murphy, Joy Krause, Sara Kono, Anna Cox, Lonnie Algreen, Karla Cronin

**SHIPPING DEPARTMENT**

*Supervisor:* Nancy Johnson ▪ *Fulfillment:* Gloria Sheehan, Chuck Carlson, Sylvia Carey, Larry Prime

ShopNotes® (ISSN 1062-9696) is published bimonthly (Jan., March, May, July, Sept., Nov.) by Woodsmith Corporation, 2200 Grand Ave., Des Moines, IA 50312. ShopNotes® is a registered trademark of Woodsmith Corp. ©Copyright 1994 by Woodsmith Corporation. All rights reserved.

**Subscriptions:** Single Copy, \$4.95. One year subscription (6 issues), \$19.95. Two years (12 issues), \$35.95. Canada/Foreign, add \$5.00 per year.

**Second Class Postage Paid** at Des Moines, IA and at additional offices.

**Postmaster:** Send change of address to ShopNotes, Box 11204, Des Moines, IA 50340-1204

**Subscription Questions?** Call 1-800-333-5854, 8am to 5pm, Central Time, weekdays.

PRINTED IN U.S.A.

# Cutoffs

One of the quickest ways to gather a crowd in our shop is with a new jig. Everyone is curious to see what it is and how well it works. And there are always comments — both good and bad. After considering all of the comments, a new design pops up a few days later. This process continues until there aren't any more concerns, and the jig is finalized.

**A DOUBLE TAKE.** But when I saw everyone standing around the "jig" in the photo, I have to admit I did a double take.

Knowing that the shop guys do have a sense of humor, I was hesitant to ask what it was. It reminded me of the cartoons that "Rube" Goldberg drew years ago. (He specialized in deviously complex and impractical inventions.) Was it really what it looked like — a power feeder for the band saw?

When I finally gave in and asked, Phil, our Assistant Editor, said it was in fact an automatic board feeder for the band saw. But it *wasn't* a jig for the magazine (thank goodness).

**RESAWING.** Instead, he was working on an article for this issue on how to resaw wood on the band saw. As we got to talking, I found out that he had built the "jig" because he was curious about band saw blades. Although we both acknowledged that most woodworkers use a 1/2"-wide blade for resawing, he wasn't satisfied recommending a blade until he had tested them all. (For more on this, see the article on page 12.)

**AN OPEN MIND.** But curiosity just isn't enough. To really grow (and get

better) at woodworking, you have to keep an open mind. And not be afraid to challenge any of the traditional methods and techniques.

**DOVETAILS.** In keeping with this train of thought, we've included an article in this issue on how to cut dovetails by hand. What makes this article different is that it challenges the traditional method of cutting dovetails. That is, cut one half of the joint first, then try to get the other half to fit it perfectly.

I like to think of our technique as a way to "sneak up" on a perfect dovetail. It's the direct result of watching Ken, our Design Director, cut dozens of dovetails.

Although Ken's method requires patience (and a little bit of practice), it's hard to argue with results — perfect, flawless dovetails. (For more on cutting dovetails by hand, see the article on page 22.)

**E-MAIL.** But keeping an open mind does take some effort. I know it was a challenge for me to accept "electronic mail." (Whatever happened to stamps?) We've decided to link up with the information superhighway through a couple of on-line computer services.

And as a service to our readers who have access to a computer and a modem, you can visit with us or ask a question via electronic mail. Just send E-mail (Attn: ShopNotes) to:

Prodigy: EDJE97A

CompuServe: 75330,2301

Internet: 75330.2301@compuserve.com

I look forward to hearing from you (even if I'm not sure how it all works).

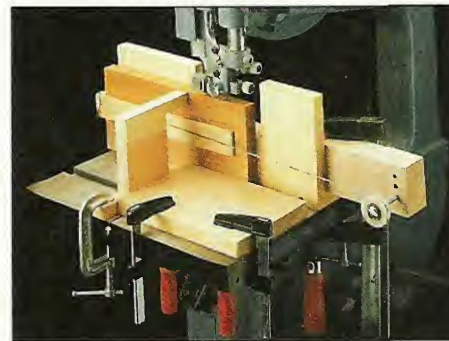

# Contents

## Jigs & Accessories

### Drawer Joint Jig \_\_\_\_\_ 4

*Working on a project with lots of drawers? This shop-made jig turns your router table into a production tool.*

### Drill Press Table & Fence \_\_\_\_\_ 16

*Make quick, accurate setups on your drill press with this table. It features a large work area and a built-in fence.*

## Projects

### Hardware Bin \_\_\_\_\_ 10

*There are plenty of drawers in this compact storage bin to help organize small parts and loose hardware.*

### Dovetailed Bookcase \_\_\_\_\_ 26

*Strength and good looks. Two reasons why dovetail joints are a perfect choice for this wall-hung bookcase.*

## In the Shop

### Resawing on the Band Saw \_\_\_\_\_ 12

*Simple tips, jigs, and techniques you can use to make thin stock out of thick boards.*

### Hand-Cut Dovetails \_\_\_\_\_ 22

*You'll be cutting dovetails by hand in no time with our step-by-step approach and a few basic tools.*

### Wood Filler \_\_\_\_\_ 30

*Two types of wood fillers — each with a place in your shop. Here are the reasons why.*

## Departments

### Shop Solutions \_\_\_\_\_ 28

*Five shop-tested tips from our readers.*

### Sources \_\_\_\_\_ 31

*Hardware and supplies for projects in this issue.*

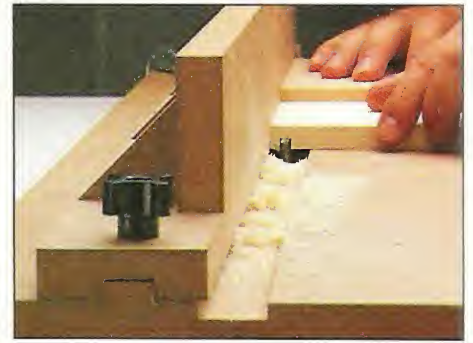

Drawer Joint Jig page 4

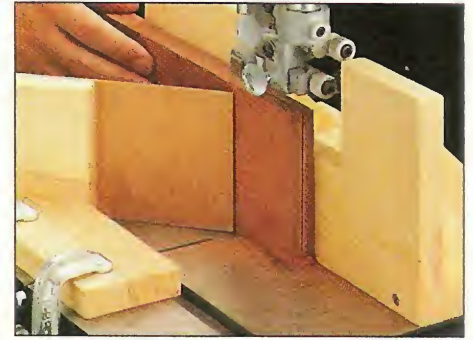

Resawing page 12



Drill Press Table page 16

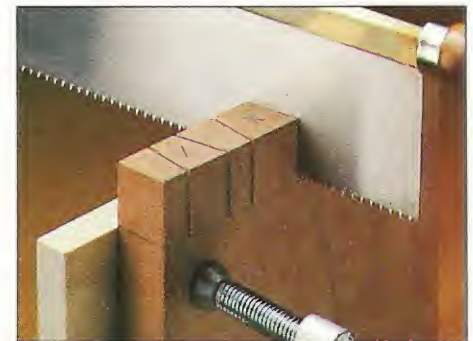

Hand-Cut Dovetails page 22

# Drawer Joint Jig

*You can build drawers like a production shop with this drawer joint jig for your router table.*



There's just something about a project with a lot of drawers that attracts me like a magnet. Especially when I start to think of all the storage possibilities.

But when it comes to making all those drawers, the time it takes always makes me wonder if there isn't a quicker solution — one that doesn't require changing the setups on your tools over and over again.

So needless to say, I was intrigued when Ken Munkel (our design director) showed me this drawer joint jig. It attaches to your router table and provides a quick, accurate way to make drawers just like a production cabinet shop.

**REVERSIBLE FENCE.** The secret to this jig is its reversible fence. It allows you to rout all the joinery you need to assemble a drawer without hav-

ing to change the basic setup of the jig.

Instead, you rout one part of the joint using the front side of the fence, see photo. Then just turn the fence around to rout the rest of the joint on the mating piece, see inset photo. By reversing the fence and changing the orientation of the workpiece, you can cut three different types of joints.

**JOINERY.** The front of the drawer is joined to the sides with a locking rabbet joint, see the Drawing below. And the back is held in place with a tongue and dado joint. You can even use the same setup to rout the groove for the drawer bottom. (We recommend a 1/4" spiral end mill bit for routing the drawer joints, see the box on opposite page.)

**Note:** To ensure that all the drawer parts fit tight together, you'll need to take the thickness of the stock into consideration. For best results, the drawer front should be at least 5/8" thick, but no more than 1 3/16" thick. And the sides and back need to be 1/2" thick. (For more information on using the jig to build a drawer, refer to page 9.)

## DRAWER JOINERY

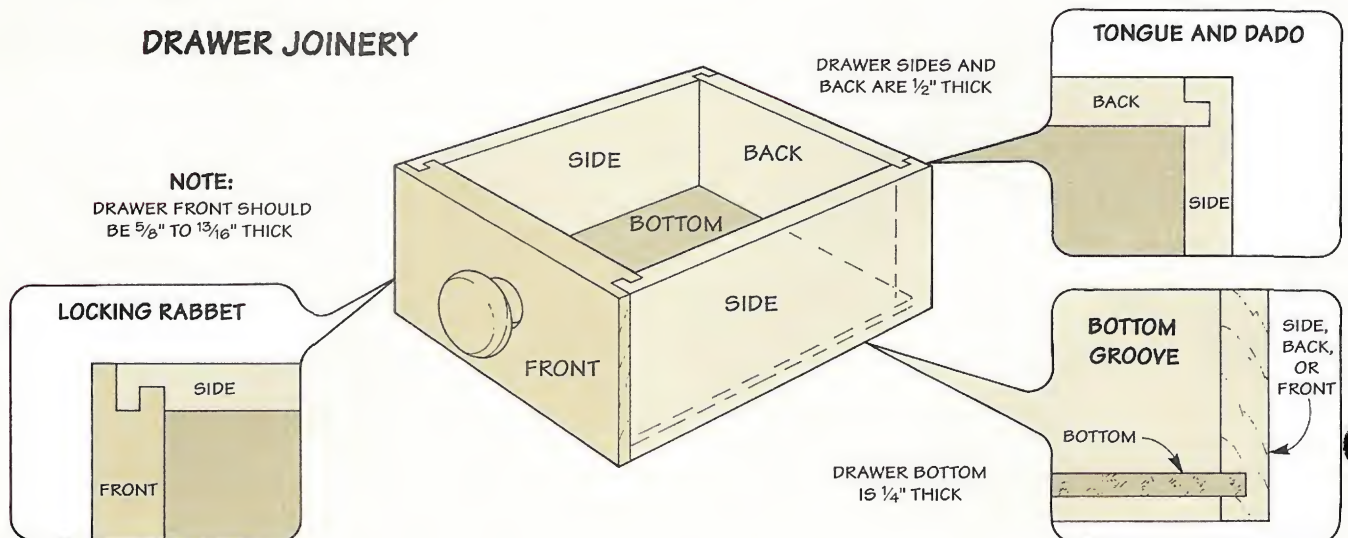

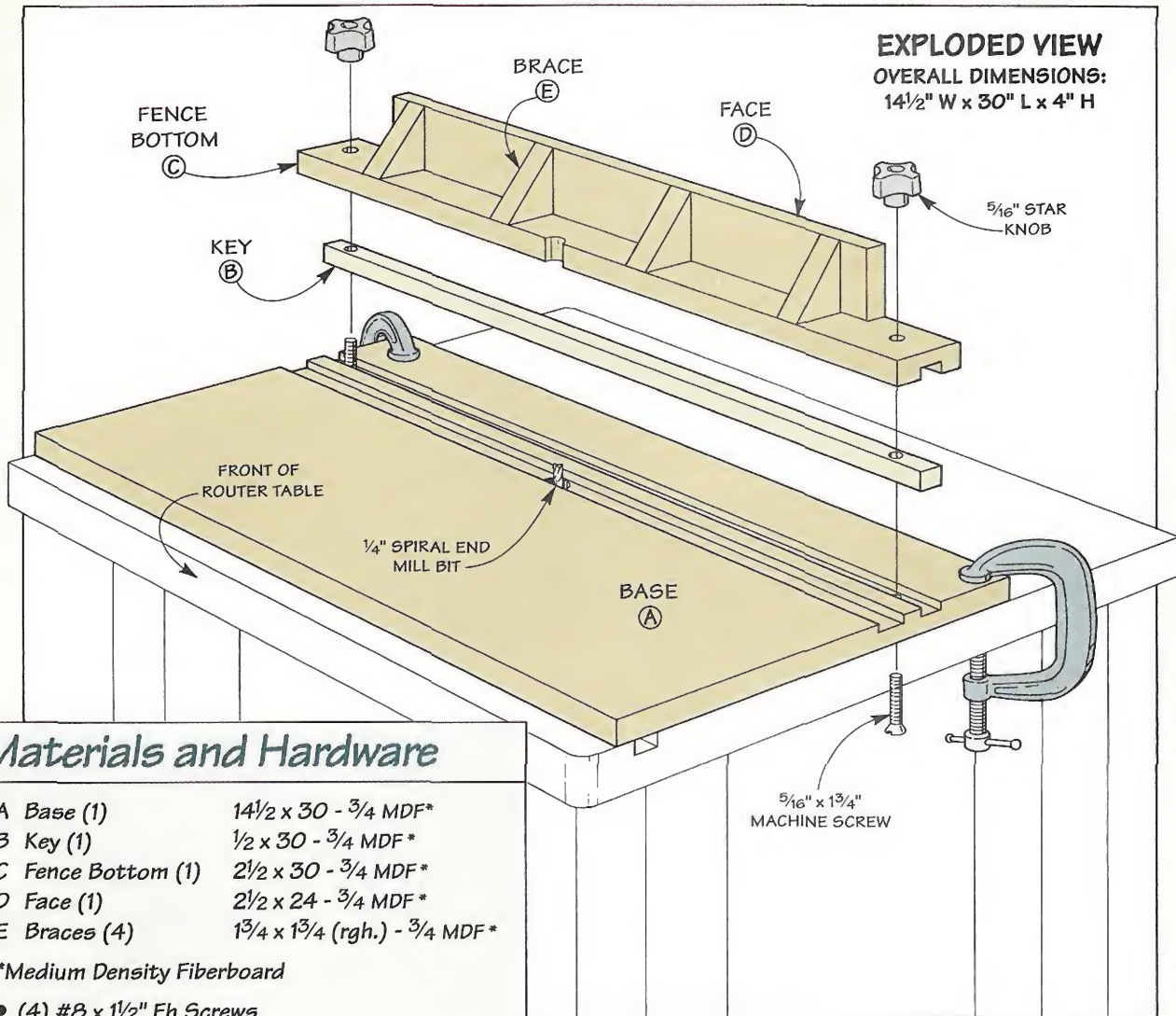

**EXPLODED VIEW**  
**OVERALL DIMENSIONS:**  
 14 1/2" W x 30" L x 4" H

### Materials and Hardware

- |                    |                                 |
|--------------------|---------------------------------|
| A Base (1)         | 14 1/2 x 30 - 3/4 MDF*          |
| B Key (1)          | 1/2 x 30 - 3/4 MDF*             |
| C Fence Bottom (1) | 2 1/2 x 30 - 3/4 MDF*           |
| D Face (1)         | 2 1/2 x 24 - 3/4 MDF*           |
| E Braces (4)       | 1 3/4 x 1 3/4 (rgh.) - 3/4 MDF* |

\*Medium Density Fiberboard

- (4) #8 x 1 1/2" Fh Screws
- (2) 5/16" x 1 3/4" Machine Screws
- (2) 5/16" Plastic Star Knobs



### Spiral End Mill Bits

A clean cut that doesn't clog up. That's why I mount a spiral end mill bit in the router when using the drawer joint jig, see photo.

**CLEAN CUT.** Because of its spiral design, the cutting edges contact the wood at an angle. So instead of chopping the wood fibers like a straight bit, it produces a clean, slicing cut.

**CHIP CLEARANCE.** The spiral design of the bit also allows for fast chip clearance. Unlike a

straight bit that shoots chips out to the side and clogs up the cut, the spirals pull the chips down and out, see Drawing.

**NO BURN.** And since the chips are removed faster, the bit doesn't have a chance to heat up. So there's less tendency for the wood to burn. This means the bit lasts longer too — especially if you use a solid carbide spiral end mill bit. (For sources, see page 31.)

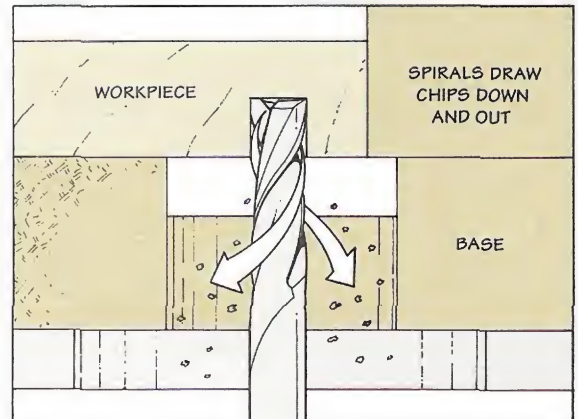

# Base & Fence

The drawer joint jig consists of two parts: a two-piece base and a fence, see Drawing. To ensure that these parts stay flat and dimensionally stable *after* the jig is built, I used 3/4"-thick Medium Density Fiberboard (MDF). (It's available at many lumber yards and home centers.) But you could also use plywood.

**BASE.** The base of the jig is designed to clamp to the top of a router table. So it needs to be long enough for the jaws of the clamps to reach (but not so long it hangs over the edges). And wide enough to provide plenty of support for the workpiece. In my case, the *base (A)* is 14 1/2" wide and 30" long, see Fig. 1.

**DRILL HOLE.** To provide an opening for the router bit to stick up through, a 1"-dia. hole is drilled in the base. This hole is centered on the length of the base. But to create a large support area for the workpiece, it's located closer to the back edge, see Fig. 1.

**GROOVES.** After drilling the hole, the next step is to cut two grooves in the base. A wide (1") groove passes directly over the hole and serves as a track for the workpiece when it's held on end. And a narrow (3/4") one accepts a "key" that's added next.

**KEY.** The *key (B)* is just a strip of MDF that's glued in the groove, see Fig. 2. In use, the key fits into a corresponding groove in the bottom of the fence, see detail in Drawing above.

All that's left is to drill holes through the base and key for a pair of 5/16" machine screws that are added later. Note: To prevent the screws from turning, I drilled slightly undersize (9/32") countersunk shank holes, see Fig. 2.

## FENCE

With the base complete, the next step is to add a fence to guide the workpiece. The unusual thing about this fence is you use *both*

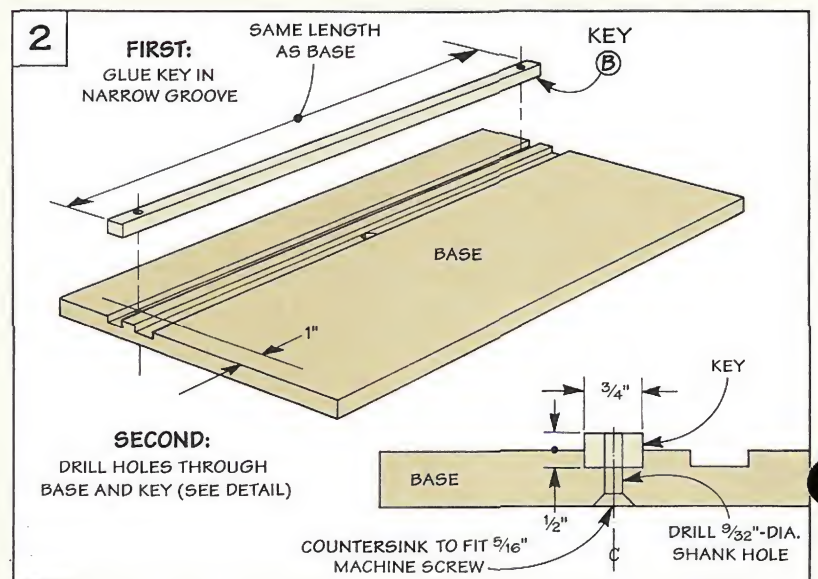
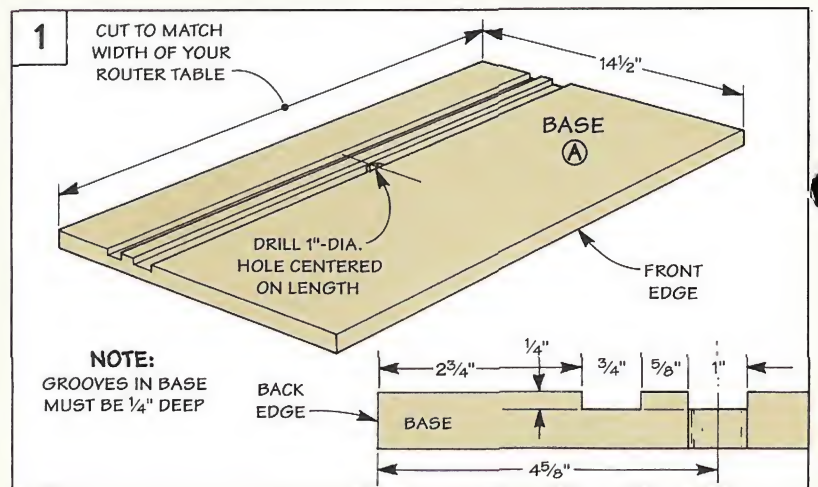
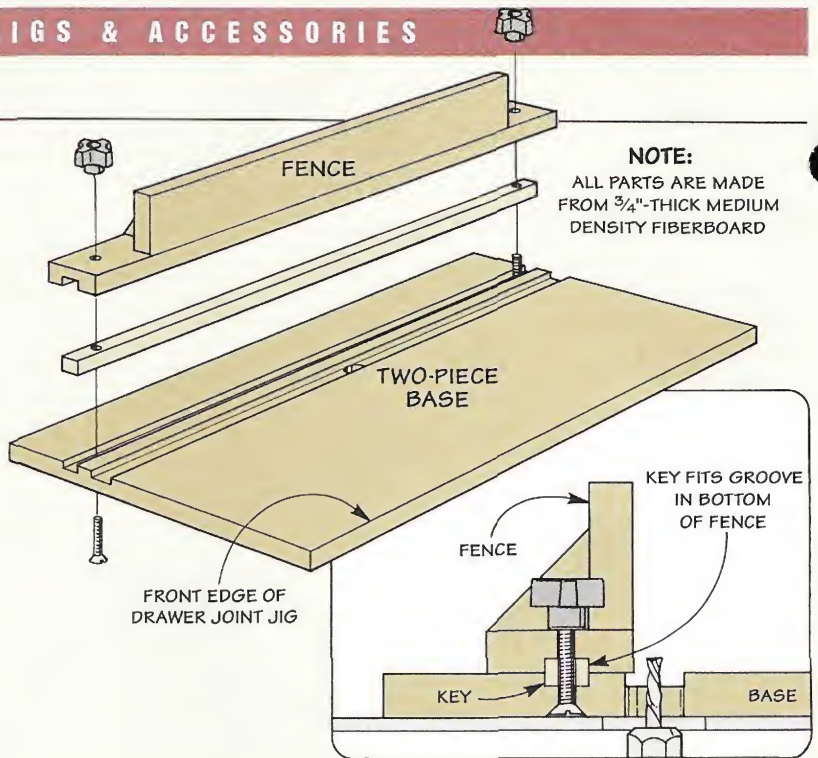

sides to rout the drawer joints, see photos at right.

The reason is simple. Turning the fence around changes the distance between the router bit and the fence. This means you can use the front of the fence to cut part of the joint (a groove or dado). And the back of the fence to cut the mating part (a rabbet).

**BOTTOM.** What makes this work is the *bottom* (C) of the fence, see Fig. 3. To position the fence on the base, there's a groove cut in the bottom that fits over the key (B).

The important thing is the *location* of the groove. To automatically position one side of the fence  $\frac{1}{4}$ " closer to the bit than the other, the groove is cut so there's  $\frac{1}{4}$ " difference in the width of the shoulders, see Fig. 3.

Next, to provide clearance for the router bit when using the back of the fence, I drilled a semi-circular opening on the back edge of the bottom piece (the one on the wide side of the groove), see Fig. 3 and margin tip at right.

**FACE.** Now you're ready to add the *face* (D). This is a  $2\frac{1}{2}$ "-wide (tall) piece that's used to support a workpiece when it's held on end. After attaching the face with glue and screws, I glued on four triangular *braces* (E) to strengthen it.

**LOCKING SYSTEM.** All that's left to complete the jig is to provide a way to lock the fence down once you set it on the key. It's held in place with two machine screws and a pair of plastic knobs (or wing nuts), see Fig. 4.

The screws pass through the holes drilled earlier in the base and key and into holes in the fence bottom (C). To locate these holes, I placed the fence over the key and used a brad point bit to mark the centerpoint, see Fig. 4a.

**INSTALL FENCE.** Finally, after drilling the holes, you can install the fence. Just thread the machine screws in, set the fence in place, and tighten the knobs.

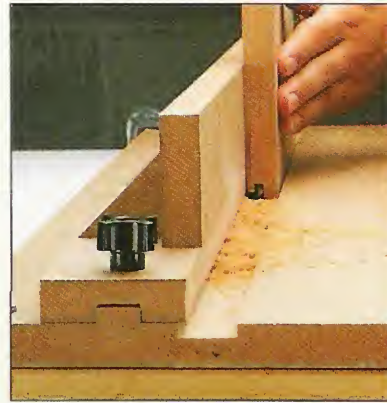

**Front.** When routing a groove (or dado), the key automatically positions the tall front part of the fence  $\frac{1}{4}$ " from the router bit.

**Back.** Because the groove that fits over the key is offset, the back of the fence allows you to cut a rabbet on the end of a workpiece.

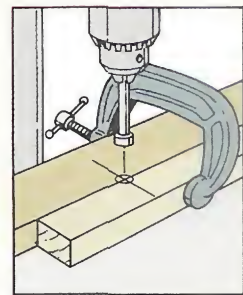

To drill a curved opening on the edge of a workpiece, clamp a support block next to it.

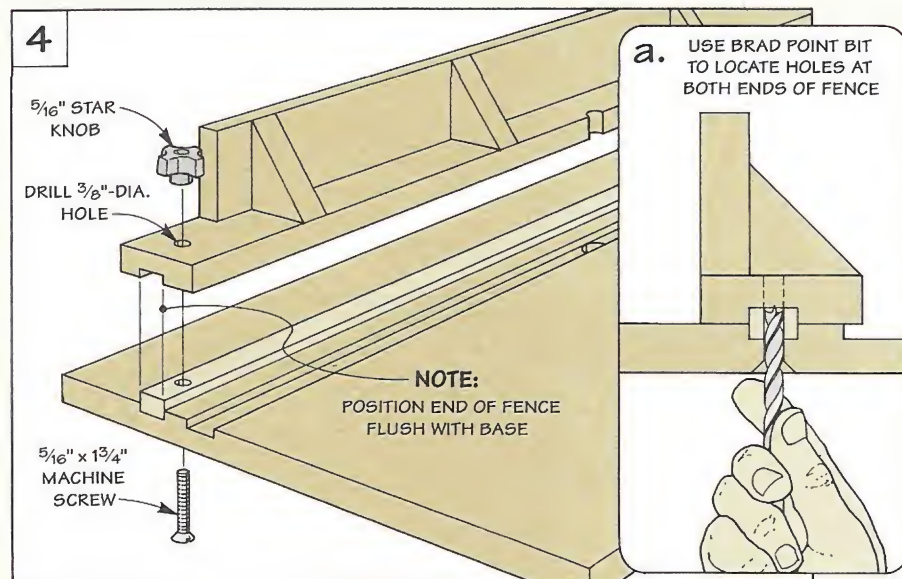
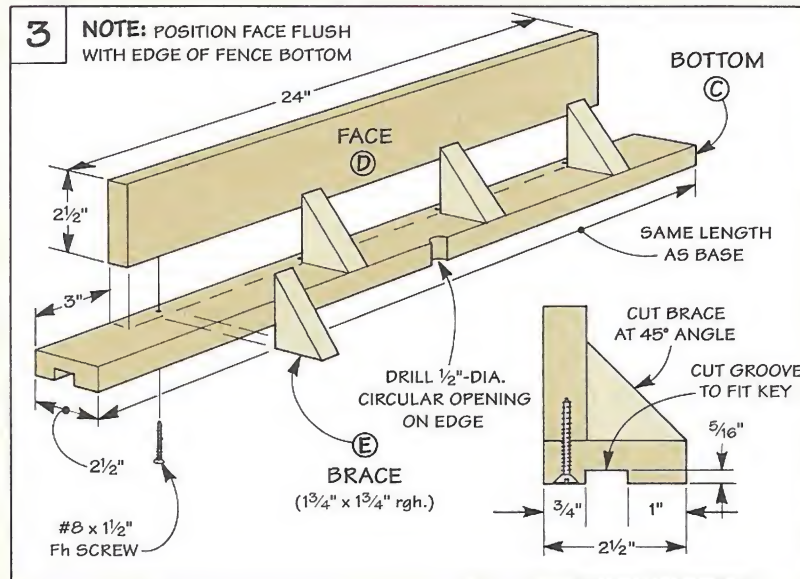

# Setting Up the Jig



Fence is too far from bit.



Fence is too close to bit.



Fence is in correct position.

To set up the drawer joint jig, you'll need to do two things: position the jig on the router table, and adjust the height of the bit.

**POSITION JIG.** The jig is positioned so the front (tall) part of the fence is exactly  $\frac{1}{4}$ " away from the router bit. This ensures that the parts of the joinery that are cut using the *front* of the fence as a guide fit snug with the parts that are cut using the *back* (short) side.

Start by roughly positioning the jig so the hole in the base fits over the bit, see Step 1. Then fine tune the location and clamp the jig in place, see Step 2.

**TEST PIECES.** To check the setup, you'll need to make a test cut with pieces that are the same thickness as the drawer pieces, see Step 3. So I plane all the drawer stock to the correct thickness (refer to page 4) and make

extra pieces for the test cuts.

**ADJUST BIT.** Now all you have to do is set the height of the router bit. To produce a tight fit, the bit needs to stick up exactly  $\frac{1}{4}$ " above the base of the jig.

Here again, the best way to check this is to make test cuts, see Steps 4, 5, and 6. Only this time, you'll need to cut a test front and side piece, reversing the fence after the first cut.

## Position Jig

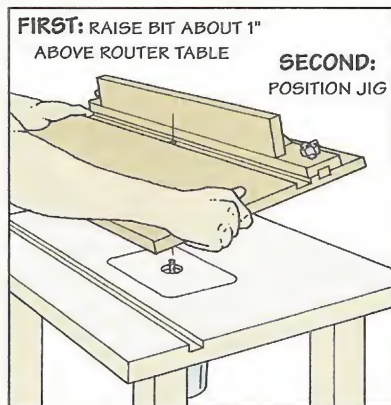

**Step 1:** After mounting a spiral end mill bit, position the jig on the router table so the bit is roughly centered in the hole in the base.

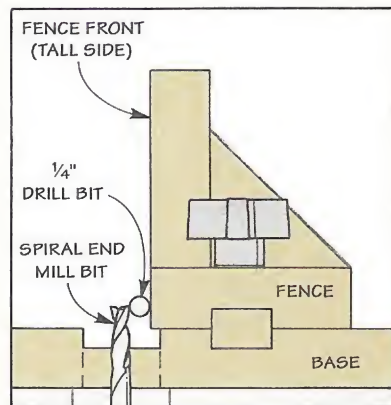

**Step 2:** Using a  $\frac{1}{4}$ " drill bit as a spacer, move the jig so the fence is exactly  $\frac{1}{4}$ " from the router bit. Then clamp the jig to the table.

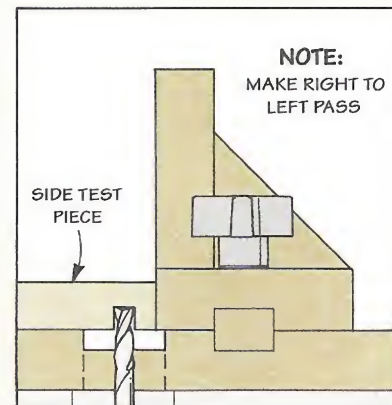

**Step 3:** To check whether the jig needs to be repositioned, rout a dado in two side test pieces and fit them together (see margin).

## Adjust Bit Height



Bit is too high.



Bit is too low.



Bit is correct height.

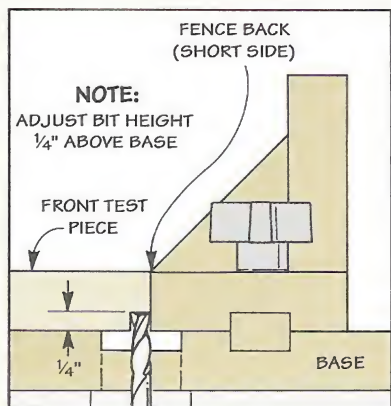

**Step 4:** With the fence positioned so the tall face is away from the router bit, cut a rabbet on the end of a front test piece.

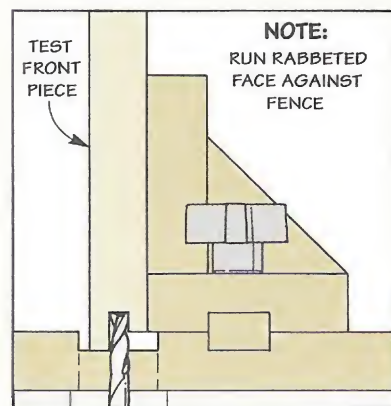

**Step 5:** Now reverse the fence and cut a groove in the end of the same piece by making a right to left pass.

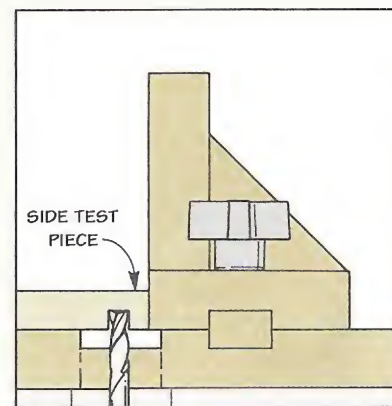

**Step 6:** After routing a dado in a side test piece, check the fit of the pieces and adjust the height of the bit if necessary (see margin).



# Building a Drawer

Once the jig is set up, you can make one drawer or go into "production mode" and build a dozen. But no matter how many you make, there are some things to keep in mind to produce tight-fitting joints.

**SIZE.** Before routing the joinery, you'll need to cut the drawer pieces to size. Determining the width is easy — they're all  $\frac{1}{16}$ " narrower than the height of the opening. But the lengths will vary.

To slide the drawer in and out without binding, the front is cut  $\frac{1}{16}$ " shorter than the width of the drawer opening. And, to allow for the joinery, the back is  $\frac{1}{2}$ " shorter than the front. Before cutting the sides to length, you'll need to take the depth of the drawer opening and the joinery into consideration.

**MARK PARTS.** Next, to avoid accidentally routing the wrong drawer part (or the wrong side of the piece), I label the front, back, and sides. Then mark the inside and outside faces of each piece.

**BACKING BOARD.** Another thing that can keep problems from cropping up is to use a scrap of wood as a backing board when routing. By supporting the wood fibers where the bit exits, it reduces chipout. And with narrow workpieces, it's safer and keeps the ends square to the fence (or base).

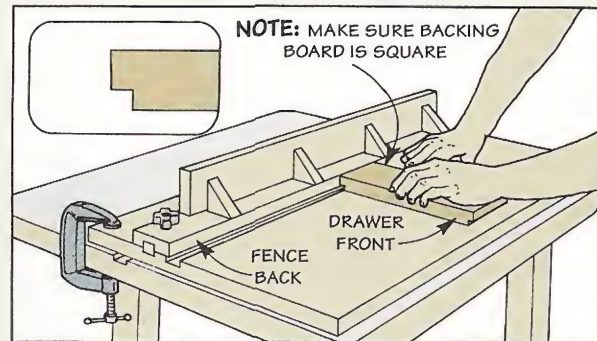
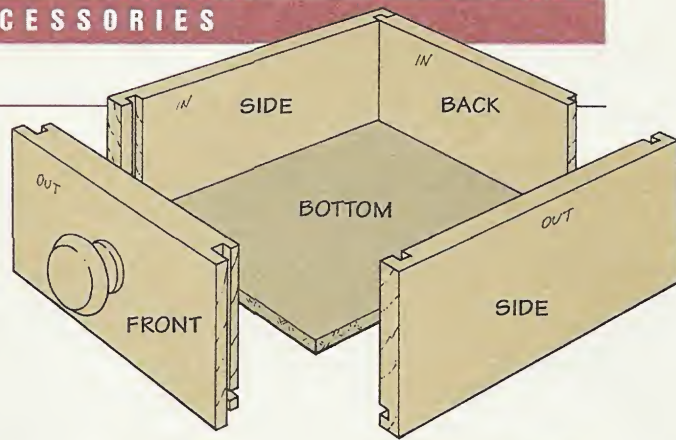

**Step 1:** With the back of the fence toward the router bit, make a right to left pass to cut a rabbet on the inside face of each end of the front piece.

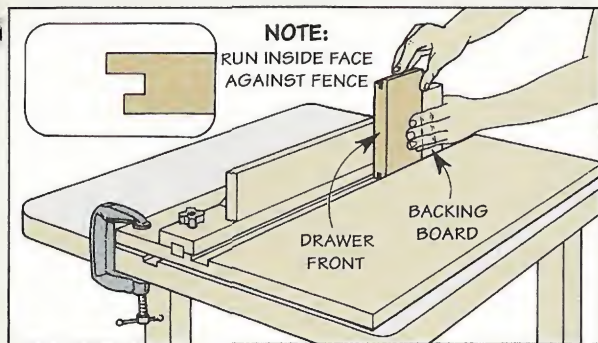

**Step 2:** To support the workpiece when it's standing on end, turn the fence around so the tall side faces the bit and rout a groove in each end.

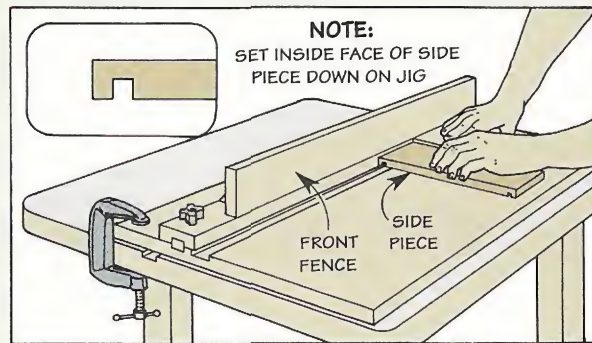

**Step 3:** Without moving the fence, place the inside face of each side piece down on the table, and rout a dado near each end.

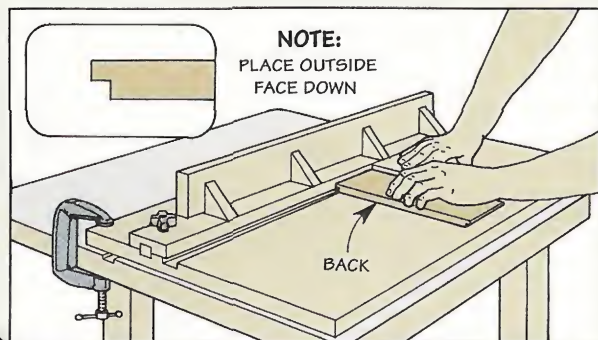

**Step 4:** After reversing the fence, place the outside face of the back piece down on the jig and cut a rabbet on each end of the workpiece.

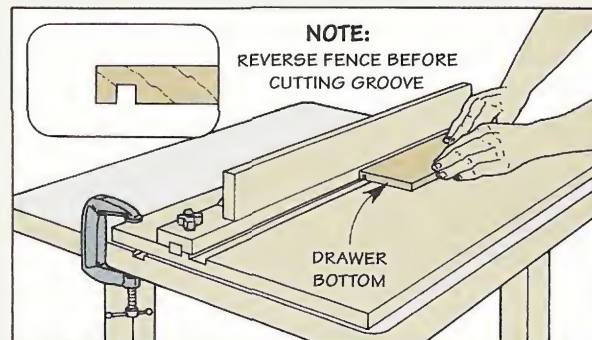

**Step 5:** If the stock you're using for your drawer bottom is  $\frac{1}{4}$ "-thick, rout a groove near the bottom edge of each of the drawer pieces.

# Hardware Bin

*Here's a handy storage bin for organizing small parts and loose hardware.*

This small hardware bin can make a big difference in the clutter that tends to pile up in a shop. Although it's only about as big as a tackle box, it still holds enough drawers to organize lots of loose parts and hardware.

And since there are a number of drawers in this project, it's a perfect opportunity to use the drawer joint jig shown on page 4. This jig lets you rout the joinery for the drawers quickly and accurately.

**CASE.** I began by making the case. It starts out as a top and bottom (A) that are held together by two sides (B), see Drawing below. (I used 3/4"-thick pine.) After rabbeting the sides to accept the top and bottom, I cut dados in the top and sides for a set of shelves and dividers added next, see Detail.

**SHELVES AND DIVIDERS.** The shelves and dividers support the drawers and create a separate compartment for each one. To create openings for a large

drawer on the bottom and four small drawers above, I cut two shelves (C) from 1/2"-thick stock (pine). Then, after cutting shallow dados in the shelves, a pair of 1/2"-thick dividers (D) can be cut to fit the openings.

Now you can assemble the case. It's held together with glue

and finish nails. And the shelves and dividers are glued in place.

## DRAWERS

With the case complete, the drawers can be built to fit the openings. The drawers are held together with two simple, yet strong joints — a locking rabbet



## EXPLODED VIEW

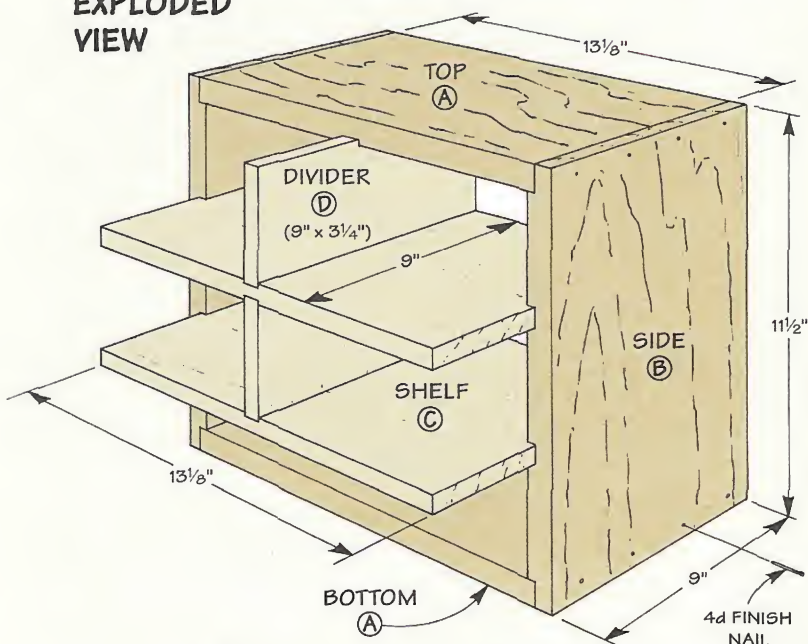

## RABBET AND DADO DETAIL

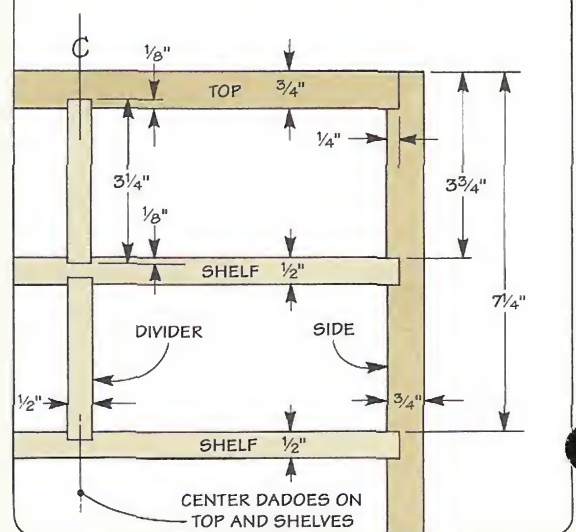

at the front corner and a tongue and dado joint at the back, see Drawing in margin at right.

I routed the joints using the drawer joint jig. But you could also cut them on the table saw. Either way, you'll need to cut the parts to size before you begin.

**THICKNESS.** To allow for the locking rabbet, I used  $\frac{3}{4}$ "-thick stock for the drawer fronts, see Fig. 1. But to keep the weight of the drawers down, the sides and back pieces are  $\frac{1}{2}$ " thick.

**WIDTH.** Regardless of the thickness, each piece is ripped to the same width. To keep the drawers from binding, they're  $\frac{1}{16}$ " narrower than the height of the openings ( $2\frac{15}{16}$ " in my case). But the length of the pieces will vary.

**LENGTH.** To determine the length of the *sides (E)*, measure the depth (width) of the case and subtract 1", see Fig. 1. (This allows for the locking rabbet and stops that are added later.)

Next, the *small (F)* and *large drawer fronts (G)* are cut  $\frac{1}{16}$ " shorter than their openings. And to allow for the tongue and dado joint, you'll need to cut the *back pieces (H, I)*  $\frac{1}{2}$ " shorter than the drawer fronts. (For step-by-step instructions on using the drawer

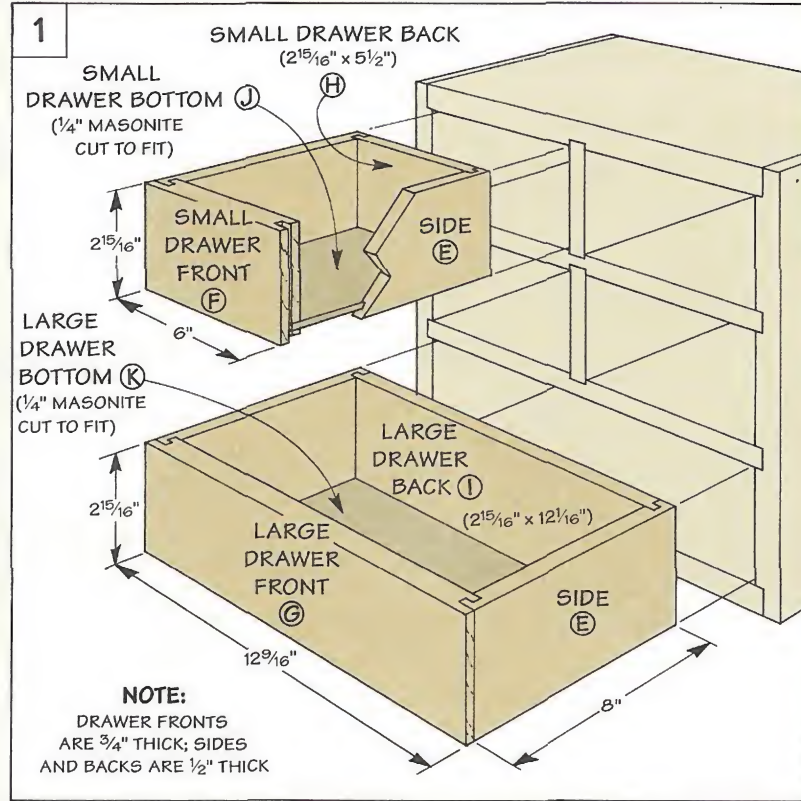

joint jig, refer to page 9.)

**CUT JOINERY.** Now you can rout (or cut) the drawer joints. Since I used  $\frac{1}{4}$ "-thick Masonite for the drawer bottoms, I routed the grooves for them as well and cut the *bottoms (J, K)* to fit.

**STOPS.** After assembling the drawers, the next step is to glue

*stops (L)* onto the shelves near the back of the drawer openings, see Figs. 2 and 2a. These are scrap blocks that keep the drawers flush with the front of the case.

**PULLS.** Finally, I screwed brass pulls to the drawer fronts, then slipped in labels to see at a glance what's inside, see Fig. 3.

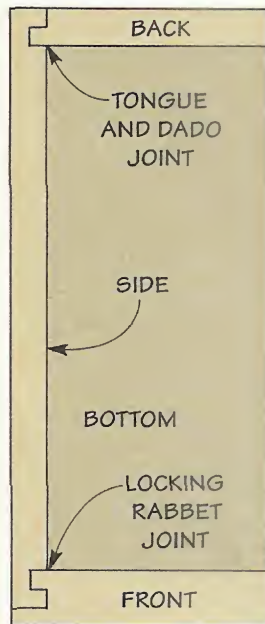
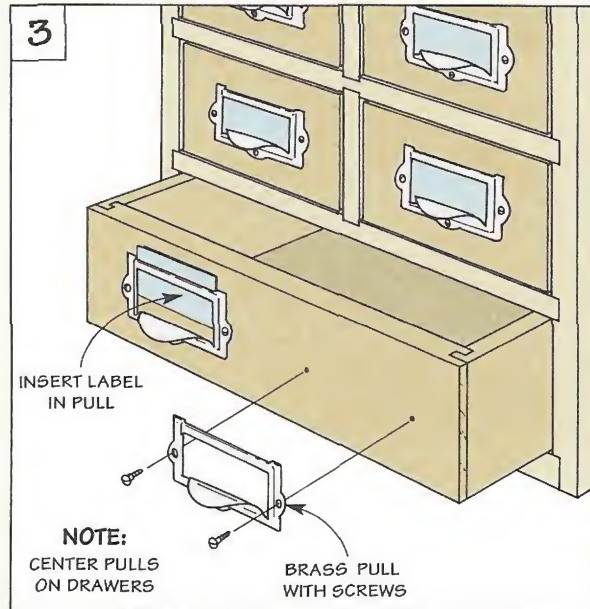
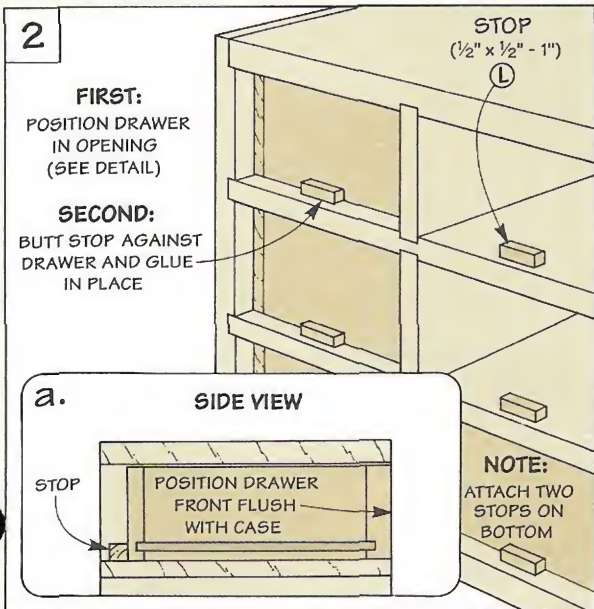

A locking rabbet and a tongue and dado joint combine to produce a simple, yet sturdy drawer.

# Resawing on the Band Saw

*It's easy to resaw lumber to any thickness with the right technique and a couple of simple jigs.*

**R**esawing on the band saw is one of the quickest and easiest ways to produce thin stock. But more importantly, it doesn't waste as much wood. Instead of repeatedly running a board through a planer to get it to the desired thickness, it makes more sense to resaw it. Then just pass it through a planer to smooth out the saw marks.

**A SIDE BENEFIT.** There's also a side benefit to resawing — you can create perfectly bookmatched panels, see photo below. This gives a glued-up panel a uniform grain pattern on each side. It makes the panel look like one piece of wood rather than a group of randomly selected boards glued together.

**THREE STEPS.** Basically, resawing is a simple three-step process. First, you'll need to select the right blade. Second, take the time to adjust the saw and the blade properly. And third, make the cut. (To ensure a smooth cut, we've included two simple jigs, refer to the boxes on pages 14 and 15.)



And just in case you run into problems, there's a troubleshooting section on page 15.

## BLADES

One of the most important steps to getting good results is to select a proper blade. If I'm planning on resawing a lot of lumber, I'll change from my everyday blade (a  $\frac{1}{4}$ "-wide, 10-tooth per inch standard blade) to a  $\frac{1}{2}$ "-wide, 4-tooth per inch hook blade, see box below. (For sources of blades, see page 30.)

Why? Because it's designed for resawing — the rake angle on this blade allows the teeth to cut more aggressively than other blade types. And the gullet



**Bookmatching.** Resawing a board is a quick and easy way to create a bookmatched panel. This is where the grain pattern on one side is a mirror image of the grain pattern on the other side.

## Blades for Resawing

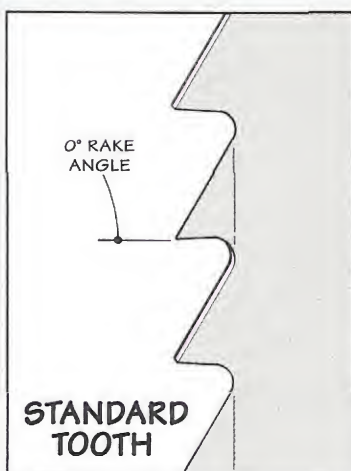

▲ **Standard.** If I only have a few boards to resaw, I'll use my everyday saw blade (a  $\frac{1}{4}$ "-wide, 10 tpi standard blade).

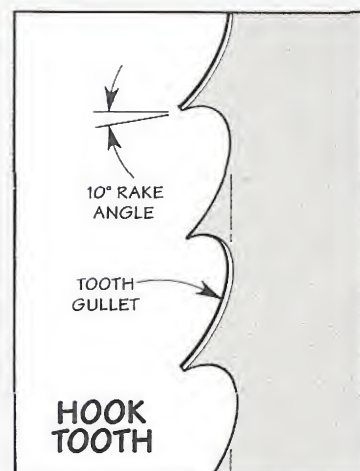

▲ **Hook.** But if I'm going to resaw a lot of boards, I'll change to a  $\frac{1}{2}$ "-wide, 4 tpi hook blade for a faster cut.

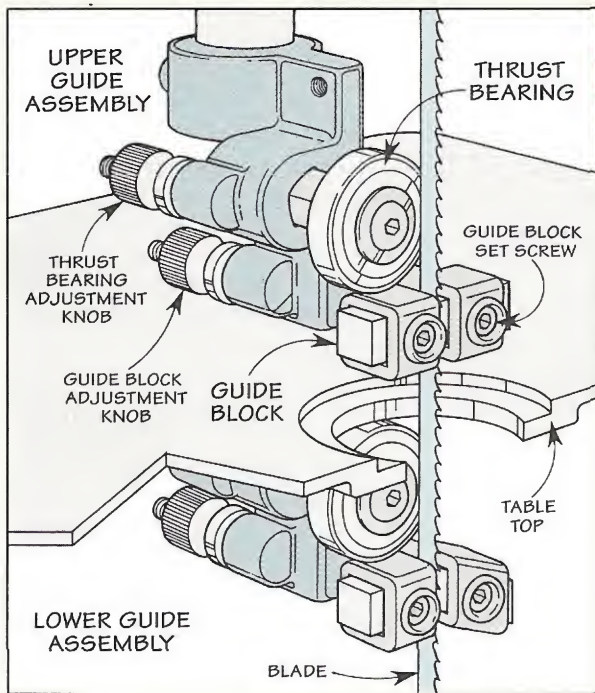

## A Quick Glance at Resawing

- Use a 1/2"-wide 4 tpi hook blade
- Remove sawdust inside the saw.
- Adjust the saw and the blade.
- Use a fence and a featherboard.
- Feed the workpiece with an even, steady pressure.
- If you have any problems, see *Troubleshooting* on page 15.

between each tooth is much deeper. So more material can be quickly removed — which reduces bogging and results in a blade that cuts better and lasts longer. Note: If I only need to resaw one or two boards, I don't change blades — the time I'd save resawing with a hook blade is lost changing blades.

### TUNE-UP

Just as critical as blade selection is saw tune-up. The band saw must be clean and tuned for peak performance. Most resawing problems can be traced to a saw that's caked with sawdust or poorly adjusted.

So before you install a blade, take the time to blow

out or vacuum any sawdust in the saw. Pay particular attention to the drive wheels, thrust bearings, and guide blocks, see Drawing above. (For a detailed article on band saw setup, see *ShopNotes* No. 13.)

Once the blade is in place, square the table top to the blade. And to help the blade track properly, adjust the thrust bearings and the guide blocks so they're almost touching the blade (a gap the thickness of a dollar bill is plenty).

Finally, provide as much support to the blade as possible by positioning the upper guide assembly as close to the workpiece as you can, but still high enough so you can see the kerf.

## Dealing with Blade Drift

All band saw blades will drift to a certain extent — some more than others. Drift is caused by an uneven set on the blade. It makes the blade pull to one side which

can produce an unusually rough surface on that side. To check for drift, see Step 1.

If the blade drift is slight, all you have to do is press the work-

piece firmly against the fence (a featherboard helps). If the blade drift is severe, you'll need to reposition your fence to match the angle of the drift, see Steps 2 and 3.

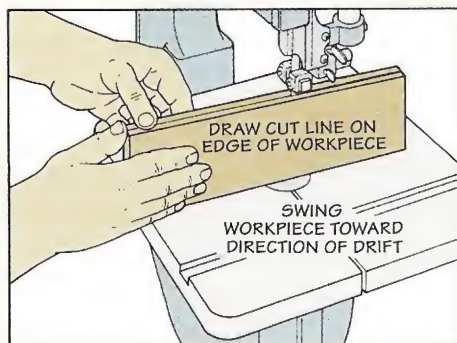

**Step 1.** Stand a scrap piece on edge and slowly feed it into blade. Swing workpiece in direction of drift and keep pushing forward.

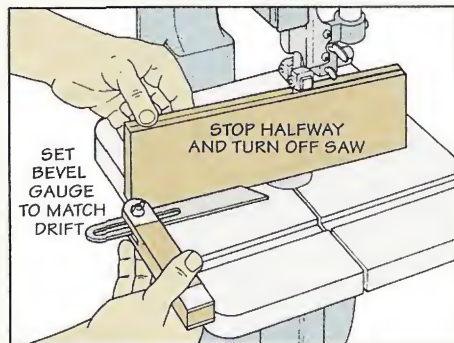

**Step 2.** Stop around the halfway point. Then butt a bevel gauge against the scrap and adjust it to match the drift.

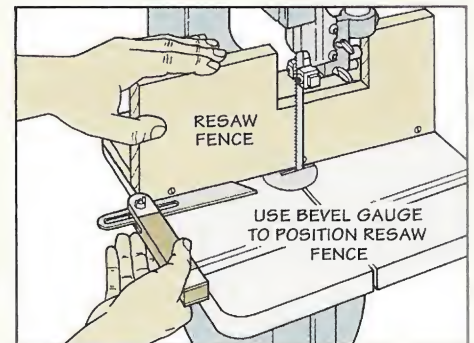

**Step 3.** Now you can use the bevel gauge to set your resaw fence to match the angle of the drift.

## Step-by-Step Resawing

After you've set up your saw, the next step is to add a fence and a featherboard, see Steps 1 and 2 (and box below and on next page).

The fence supports the work-

piece and determines the thickness of the cut. The featherboard presses the workpiece tight into the fence to ensure a straight cut.

Once they're in position, just

guide the workpiece into the blade, see Step 3. As you complete the cut, use a push block to safely push the workpiece past the blade, see Step 4.

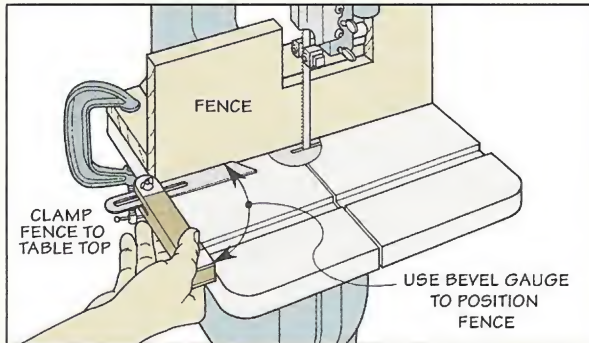

**Step 1.** For a uniform thickness and a square cut, clamp a fence to the table top. When positioning the fence, allow an extra  $\frac{1}{16}$ " for thickening.

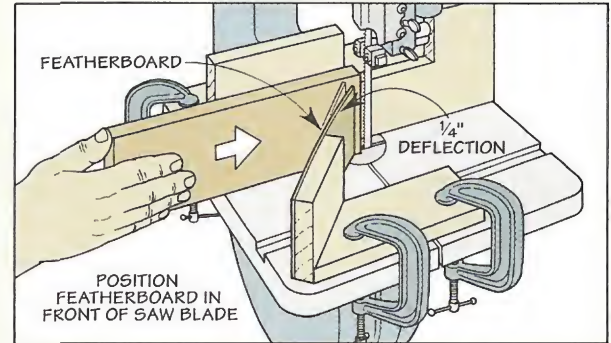

**Step 2.** To press the workpiece tight against the fence and ensure a straight cut, position a featherboard just in front of the blade.

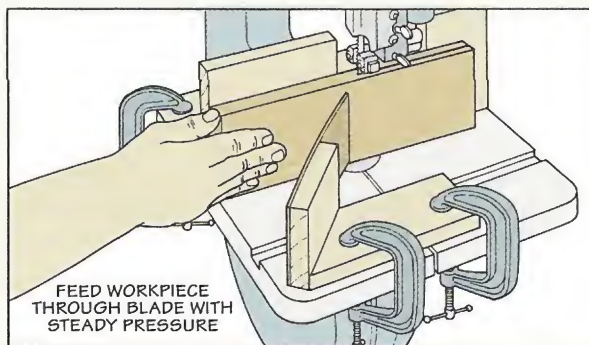

**Step 3.** To resaw, guide the workpiece into the blade with an even, steady pressure. Don't force the cut — let the blade do the work.

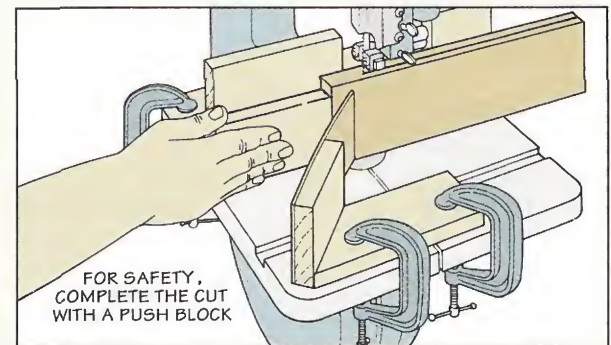

**Step 4.** To complete the cut, use a push block the same thickness as your workpiece to safely push the workpiece past the saw blade.

## Resaw Fence

For a square cut, it's important to run the workpiece  $90^\circ$  to the surface of the table top. To do this, I use a shop-made fence to support the workpiece as it's passing through the blade.

The fence is nothing more than a face screwed to a base, see Drawing. The face is high enough to support the tallest workpiece my saw will handle. A notch in the face allows the guide assembly to be lowered for shorter workpieces.

And to keep the face square to the table top, triangular-shaped support blocks are screwed to the face and base.

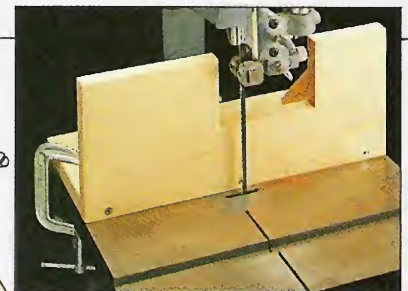
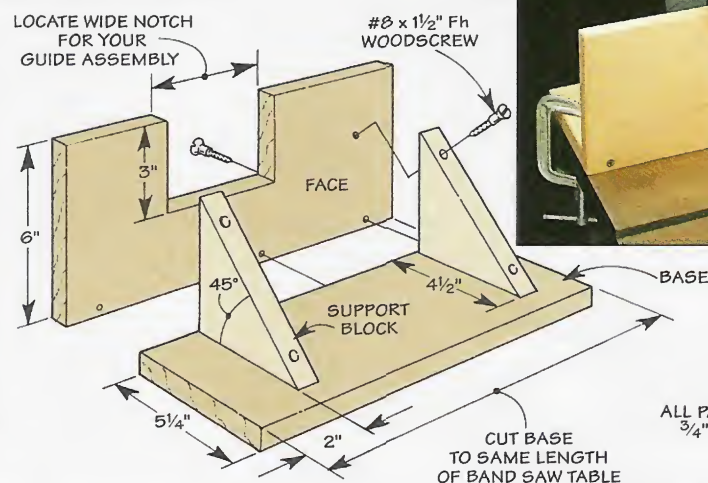

**NOTE:**  
ALL PARTS CUT FROM  
 $\frac{3}{4}$ "-THICK STOCK

# Troubleshooting Tips

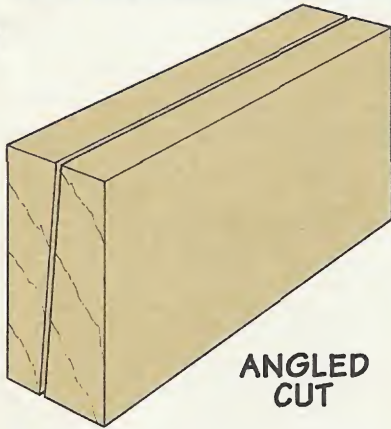

**ANGLED CUT**

▲ If you end up with a wedge-shaped cut, first check the fence and the featherboard setup. Then check position of guide blocks.

One of the most common problems when resawing is you end up with wedge-shaped workpieces. Fortunately there's an easy fix.

More than likely, the table isn't square to the blade. Or the fence isn't square to the table, see be-

low left. Also, you might try adjusting the featherboard to press harder against the workpiece.

If this doesn't solve the problem, check to make sure the guide blocks aren't forcing the blade out of alignment, see below.

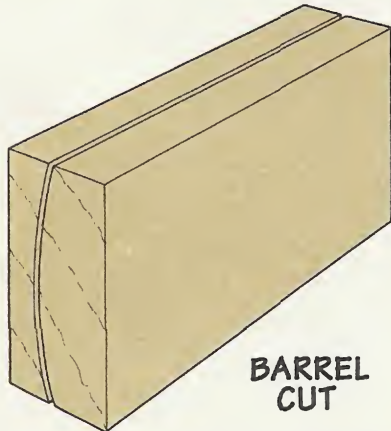
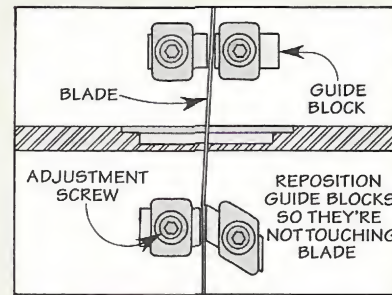
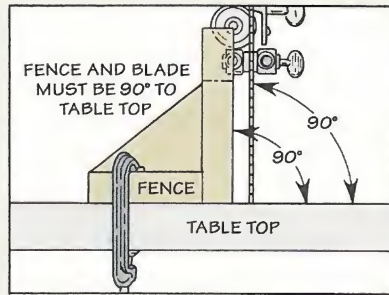

**BARREL CUT**

▲ A barrel cut can be corrected by increasing the blade tension and making sure the guide assembly is close to the workpiece.

Another common resawing problem is "barreling," see below. Barreling occurs when the blade isn't properly tensioned or supported. Two things can cause this.

First, the tension may not be properly set — just increase the

tension until it cuts straight.

Another possible cause is the position of the upper guide assembly. The closer it is to the workpiece, the less chance you'll have that the blade will flex or barrel, see below.

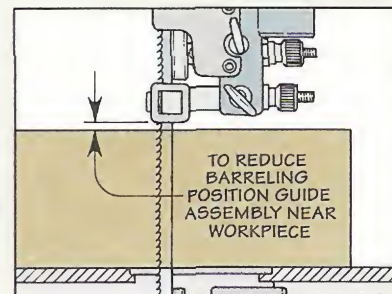
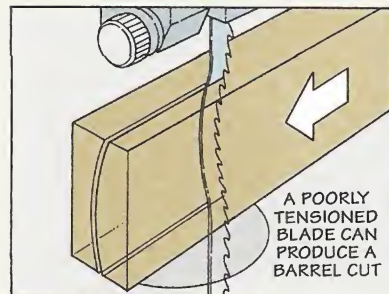

## Resaw Featherboard

One of the easiest ways to ensure a straight cut is to use a featherboard. This shop-made featherboard exerts even pressure across the total width (height) of the workpiece.

The featherboard consists of three parts, see Drawing. A base and an upper arm made from 3/4"-thick stock that hold a pressure plate (1/8" Masonite).

To allow the workpiece to slide smoothly between the fence and the featherboard, I angled the end of the base. This way, the pressure plate can be positioned 45° to the workpiece.

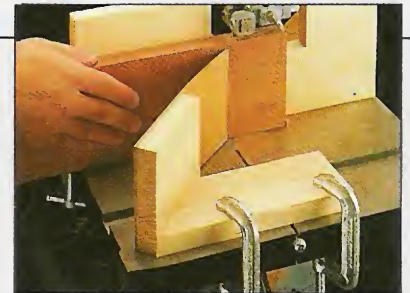
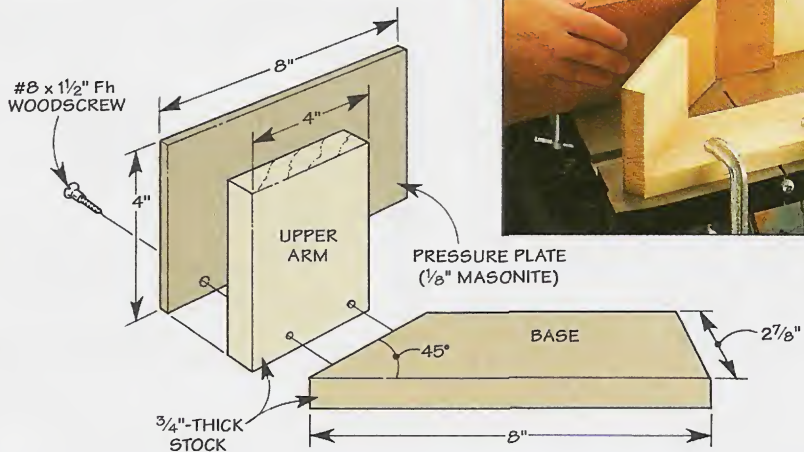

# Drill Press Table & Fence

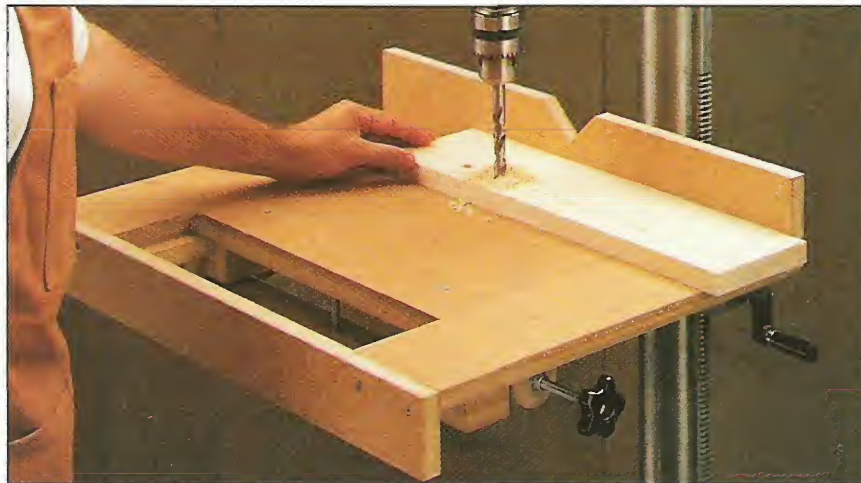

If you've ever spent too much time positioning a fence on a drill press, you'll appreciate this drill press table and fence. It combines a large work surface with a unique fence that's actually part of the table, see photo above.

**NO CLAMPS.** Attaching the fence to the table solves a couple of problems. For instance, there's no need to fumble around with clamps to hold an auxiliary fence in place. And this fence won't get lost like the ones made of scrap wood.

**TWO-PART TOP.** Nevertheless, making the fence part of the table does present a challenge. How do you make the fence adjustable? The secret is a two-part table top. One part is fixed to the metal

*This drill press table increases your work area and features a built-in micro-adjustable fence.*

drill press table. The other part slides quickly forward and backward, see photo A.

By attaching the fence to the sliding part of the table,

you can position it exactly where you want. When you're through drilling, the table slides back to move the fence out of the way.

**MICRO ADJUSTER.** And if you need to move the fence just a hair to fine tune its position, simply turn a knob at the side of the table, see photo B. It's connected to a unique adjusting mechanism located underneath the table.

**BRAKE.** Once the fence is positioned, another knob locks it in place, see photo C. Like the adjusting mechanism, the brake is operated with one hand.

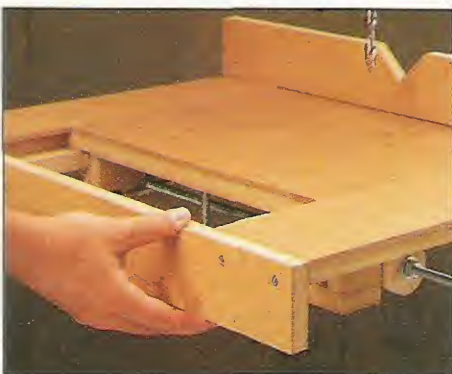

**A. Quick Adjust.** You can quickly position the fence by simply pulling or pushing the front rail of the table top.



**B. Micro Adjuster.** A mechanism under the table allows you to micro-adjust the fence to fine tune the position.



**C. Fence Brake.** Once the fence is adjusted where you want it, lock it in place by tightening the knob on the brake.



**EXPLODED VIEW**  
OVERALL DIMENSIONS:  
24"W x 18<sup>3</sup>/<sub>4</sub>"D x 8"H

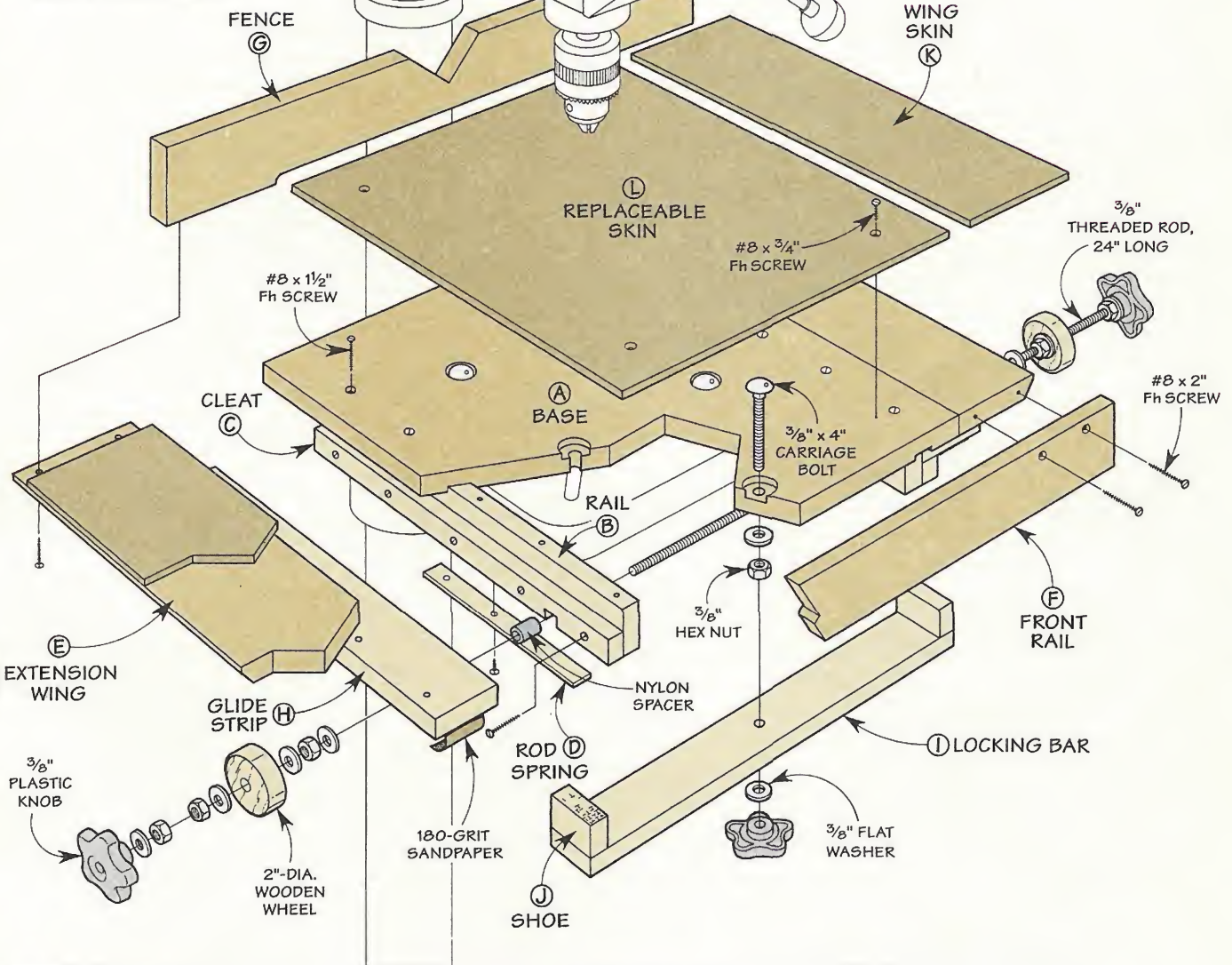

**Materials**

A Base (1)	16 x 18 - 3/4 MDF
B Rails (2)	17/8 x 15 - 3/4 MDF
C Cleats (2)	1 x 15 - 3/4 MDF
D Rod Springs (2)	1/8 x 3/4 - 8
E Extension Wings (2)	4 x 18 - 3/4 MDF
F Front Rail (1)	23/4 x 24 - 3/4 MDF
G Fence (1)	3/4 x 24 - 3/4 MDF
H Glide Strips (2)	2 1/2 x 15 - 3/4 MDF
I Locking Bar (1)	2 x 17 1/8 - 3/4 MDF
J Shoes (2)	1 1/4 x 2 - 3/4 MDF
K Wing Skins (2)	4 1/2 x 17 1/4 - 1/4 Mas.
L Replaceable Skin (1)	15 x 17 1/4 - 1/4 Mas.

Note: You'll need a piece of 3/4" MDF that's 24" x 48" and a piece of 1/8" Masonite that's 18" x 25".

**Hardware**

- (4) #8 x 2" Fh Screws\*
- (14) #8 x 1 1/2" Fh Screws\*
- (20) #8 x 1 1/4" Fh Screws\*
- (8) #8 x 3/4" Fh Screws\*
- (1) 3/8" Threaded Rod, 24" Long
- (2) 2"-Dia. x 5/8" Wooden Wheels (3/8" Bore)
- (2) 1"-Long Nylon Spacers (.385" ID. x .5" OD.)
- (3) 3/8" Plastic Knobs
- (1) 3/8" x 4" Carriage Bolt
- (7) 3/8" Hex Nuts
- (10) 3/8" Flat Washers

\* Refer to Box on page 18 before buying screws.  
Note: You'll also need hardware to mount the drill press table and fence to your drill press.

# Base

The drill press table consists of two main parts. A base and a sliding fence, see Drawing at right. I began with the base.

**BASE.** The *base* (A) provides a large work surface and supports the sliding fence. It's just a piece of medium density fiberboard (MDF) that's bolted to the table top of the drill press, see Drawing.

I made most of this drill press table from 3/4"-thick MDF and 1/4" Masonite — two engineered wood products that are strong, stable, and inexpensive. But you could also use 3/4"-thick plywood.

To locate the holes for the mounting hardware, first center the base (A) on the table of the drill press, with the back against the column, see Fig. 1.

Then mark the location of the holes by tracing the slots in the table to the bottom of the base (A). Once the slots are traced, flip the workpiece over and drill a counterbored hole in the center of each slot for mounting hardware that fits your table, see Fig. 2.

At the same time, I found it easiest to drill a counterbored hole near the front edge of the base for a brake that's added later, see Fig. 2.

**GROOVES.** Once the counter-bored holes are drilled, the next

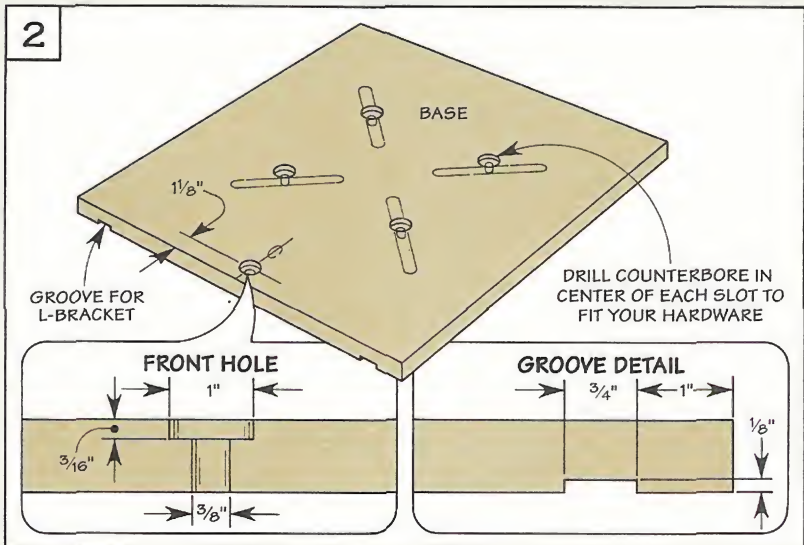
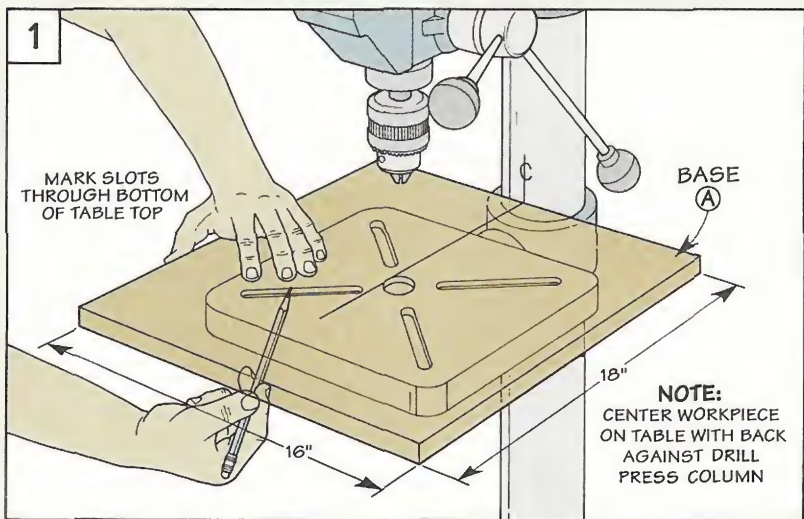
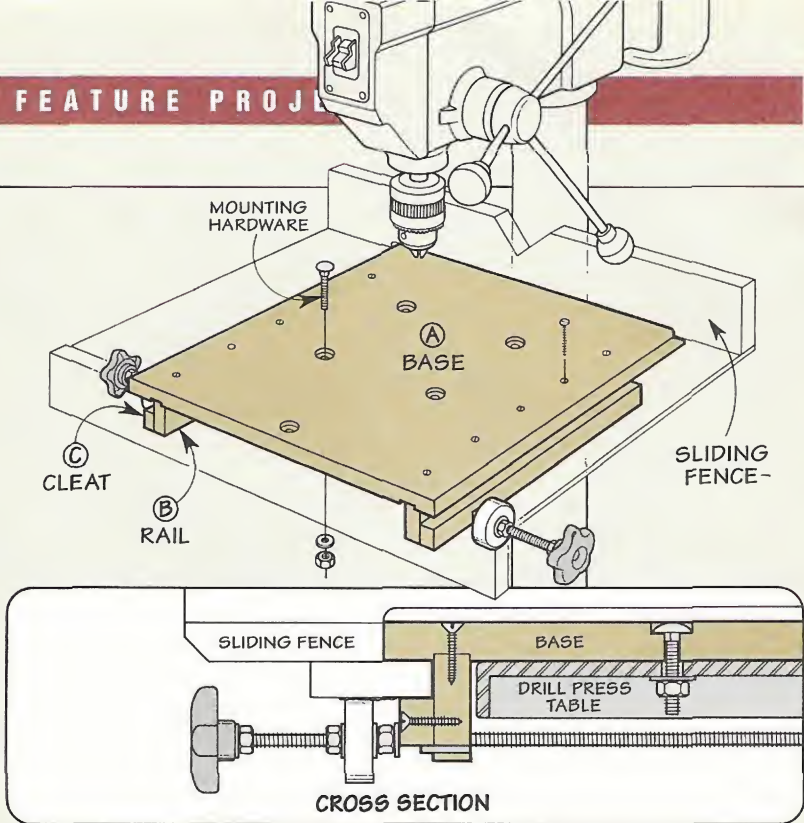

## Screwing into MDF

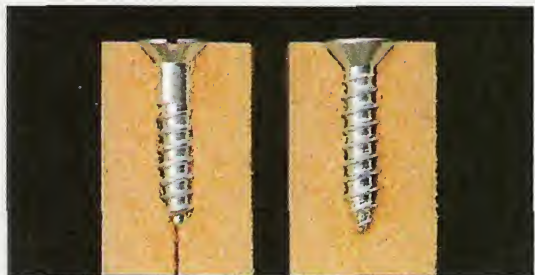

▲ It's possible to split MDF when drilling and screwing into the edge with a tapered wood-screw, left. To avoid this, drill a pilot hole and use a straight-shanked screw, right.

step is to cut two grooves on the bottom of the base for L-brackets that support the sliding fence that's added later, see Fig. 2.

**L-BRACKETS.** The L-brackets are two pieces of MDF glued and screwed together to form an "L," see Fig. 3. I cut the parts for the L-brackets 3" shorter than the grooves they fit in. There are two reasons for this.

The front of each bracket is set back 1/2" from the front of the base (A) to prevent sawdust from building up when the fence is adjusted. And they're 2 1/2" from the back to allow clearance for turning the crank handle when adjusting the table height.

Once the rails (B) and cleats (C) are cut to size, glue and screw the parts together, see Fig. 3. Note: Before drilling and screwing into MDF, see box on previous page. Also, because a notch is cut later in each L-bracket, locate the screws outside the notched area, see Figs. 3a and 3b.

Before attaching the L-brackets to the base, cut a 1/2"-wide notch in each bracket for nylon spacers used with the adjustment rod, see Fig. 4.

**ADJUSTMENT ROD.** With the L-brackets in place, all that's left to complete the base is to add a micro-adjustment rod. This rod rests in the notches you just cut in the L-brackets, see Fig. 5.

The adjustment rod is a length of threaded rod with two knobs and two wooden wheels, see Fig. 4. (For a hardware kit, see Sources on page 31.)

The rod is held in place with a pair of hardwood rod springs (D) that also press the wheels against the fence, see Fig. 5.

As either knob is turned, the rod rotates. When this happens, the wheels pressing against the bottom of the fence move the fence back and forth, refer to the Cross Section drawing on the previous page.

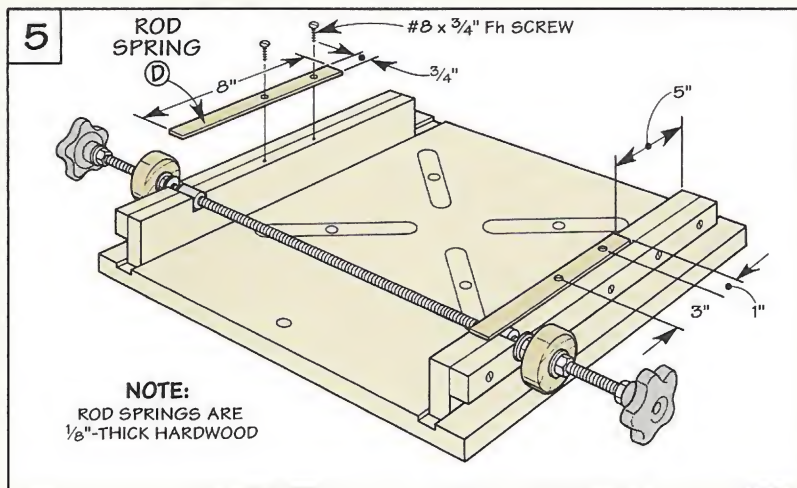
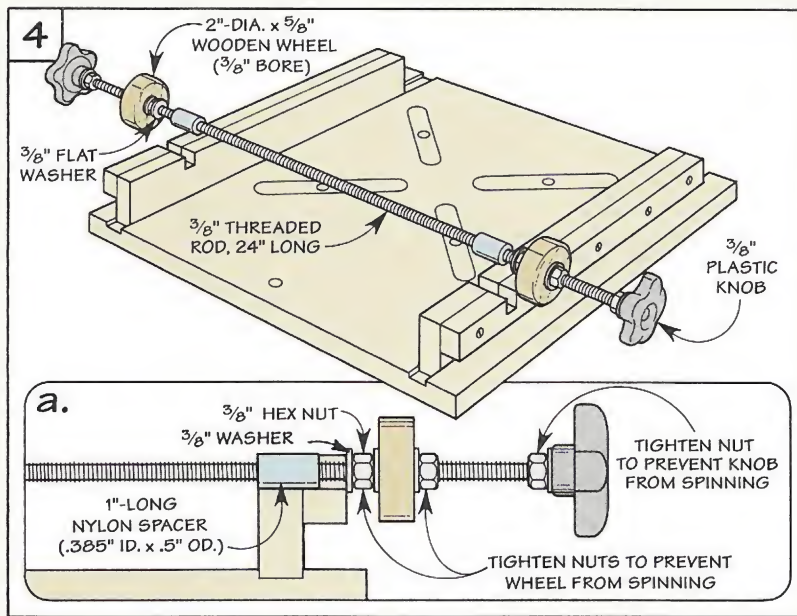
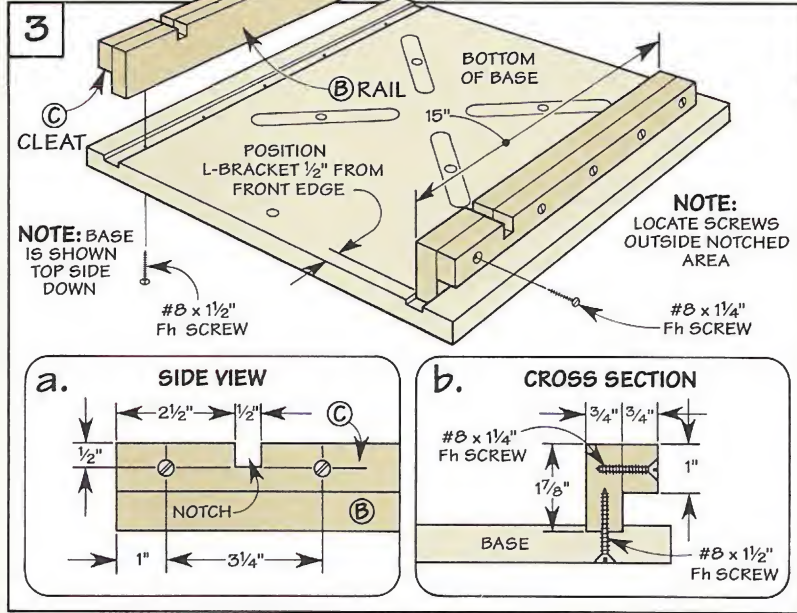

# Sliding Fence

With the base complete, the next step is to build a sliding fence to fit around the base. It consists of two extension wings, a front rail, and a fence, see Drawing.

**WINGS.** The *extension wings (E)* enlarge the work surface and support the fence. Each wing is cut to match the length of the base (18"), see Fig. 6. And to provide clearance when turning either knob on the adjustment rod, the outside edge is chamfered, see Fig. 6.

**RAIL & FENCE.** To determine the length of the front rail and fence, temporarily clamp the extension wings to the sides of the base, see Fig. 6. Then measure across the combined width. (In my case, they're both 24" long.)

After the *front rail (F)* is cut to length it can be glued and screwed to the front edge of the wings. Note: To allow room for Masonite skins added later, position the front rail up 1/4" above the wings, see Fig. 6b.

Before attaching the *fence (G)*, two more things need to be done.

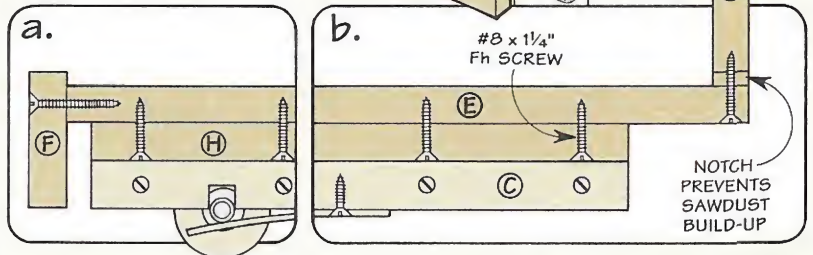
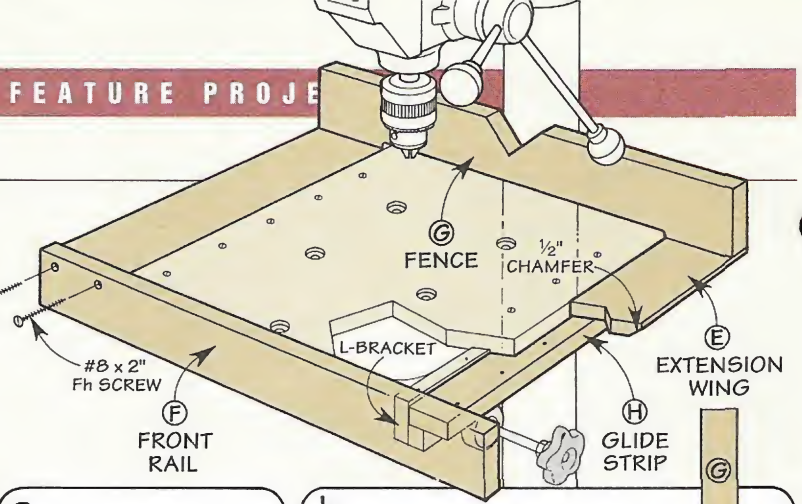

To allow the drill press chuck to clear the fence when using short or small bits, I cut a V-notch in the center of the fence.

To allow clearance for the drill press chuck, a V-notch is cut on the top edge, see photo at left. And to keep sawdust from building up, a 3/8"-deep notch is routed along the bottom edge, see Fig. 6a.

**GLIDE STRIPS.** Next, to support the sliding fence on the base and allow it to move back and forth, add a pair of *glide strips (H)*, see Fig. 7. They're cut to match the length of the L-brack-

ets (15") and are screwed to the bottom of the wings.

To make sure the glide strips slide smoothly on the L-brackets, first place the base and the fence together upside-down on a flat surface, see Fig. 7. Then sand them until they slide without binding.

Finally, for the wheels to grip the glide strips without spinning, glue 180-grit sandpaper to the bottom of each glide, see Fig. 7.

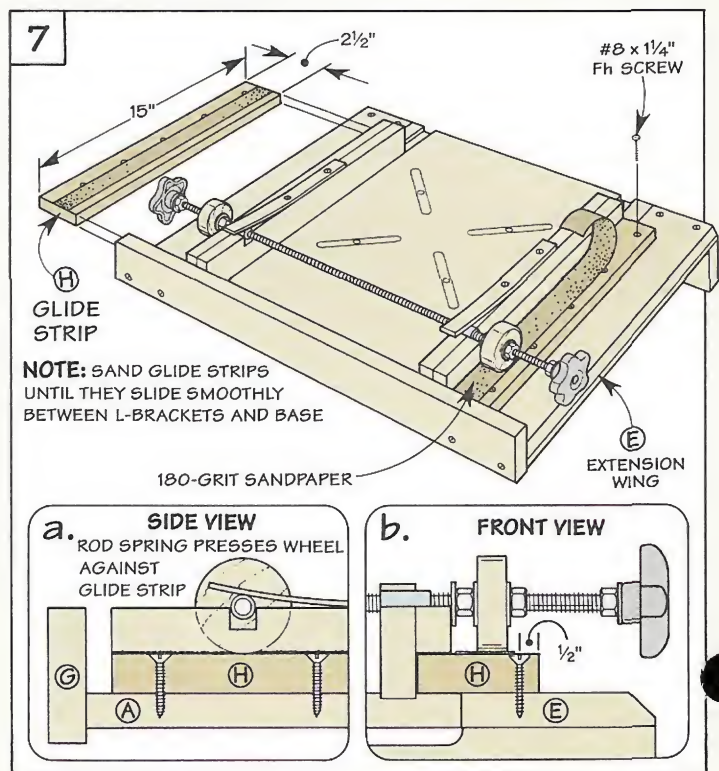
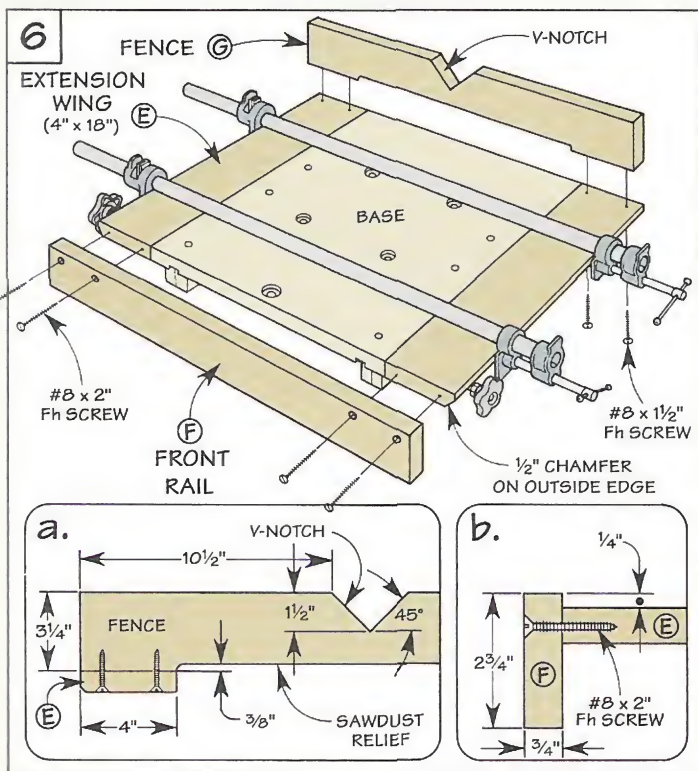

# Brake

All that's left to complete the drill press table is to add a brake to lock the sliding fence in place. The U-shaped brake hangs from a bolt that passes through the counterbored hole drilled earlier in the base, see Fig. 8.

**BRAKE.** The brake consists of a locking bar, two shoes, and a plastic knob, see Figs. 8 and 9. When the knob is tightened, the shoes press against the bottom of the glide strips (H) and prevent the fence from sliding. When the knob is loosened, the fence slides freely.

To determine the length of the *locking bar (I)*, flip the drill press table over on its top. Then measure the distance between the outside edge of the L-brackets and add 15/8", see Figs. 9 and 9a.

Now the brake can be completed by drilling a hole in the center of the locking bar for a carriage bolt. And gluing on a pair of *shoes (J)*, see Fig. 9.

Once the brake is attached to the base, the table and fence can be mounted to the metal table on

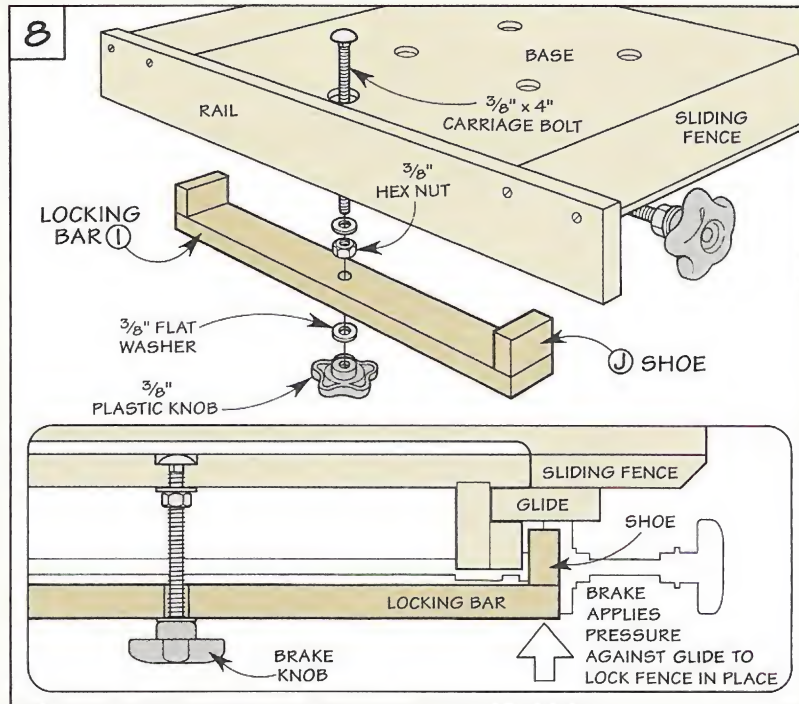

your drill press, see Fig. 10. When you position this assembly, remember to butt it up against the column of the drill press so you can get maximum use of the work surface.

**SKINS.** Finally, to protect the table and keep sawdust out of the glide strips, I glued a pair of *wing skins (K)* to the extension wings, see Figs. 10 and 10a. And screwed a *replaceable skin (L)* to the base.

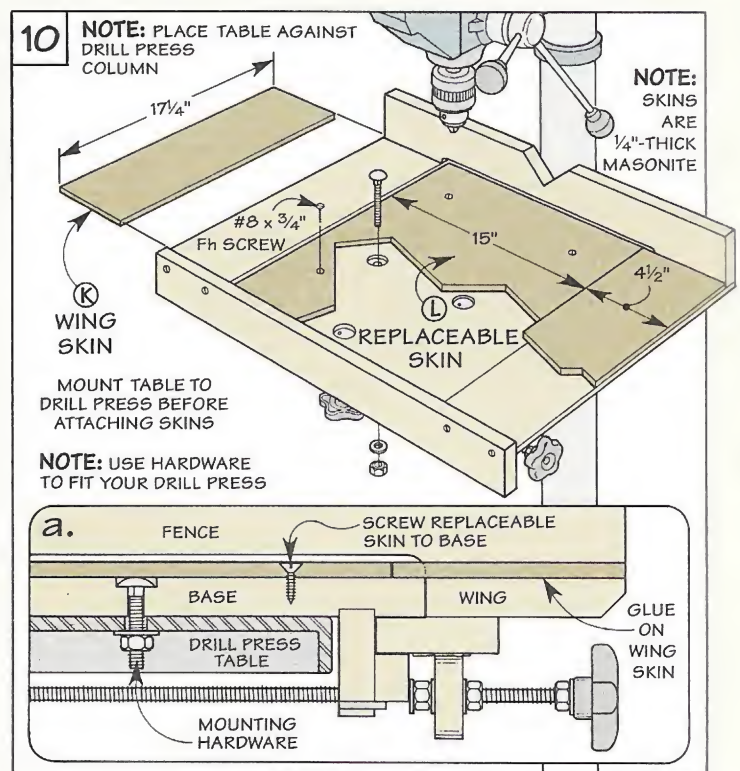
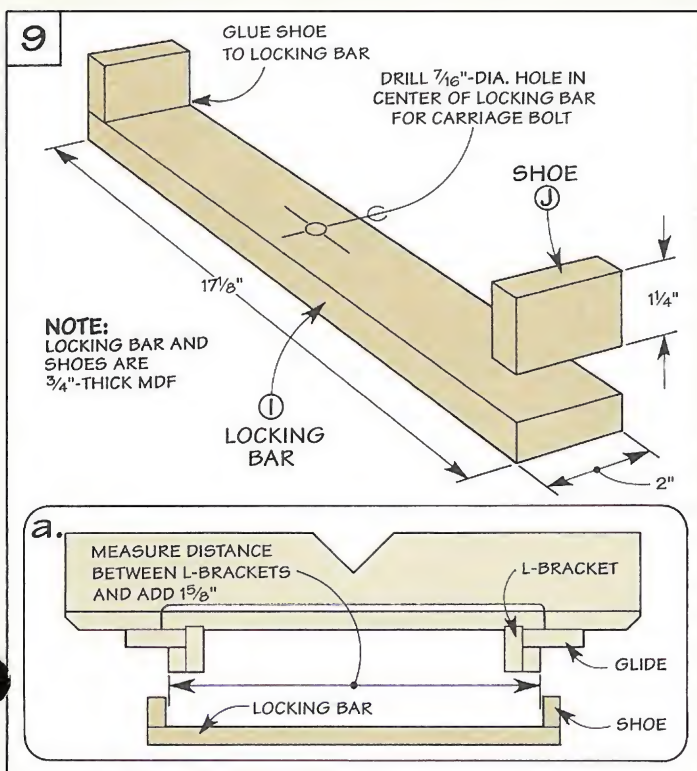

# Hand-Cut Dovetails

*A few basic hand tools and a simple step-by-step approach are all you need to cut a dovetail joint by hand.*

I'll never forget the first dovetail joint I cut by hand. Although the fit wasn't perfect, the joint was still as strong as an old oak tree.

That's because when you assemble a dovetail joint, the two interlocking parts wedge tight against each other, see the photo above right. The result is a strong, mechanical joint that won't pull apart.

While you can use a template to rout the dovetails, I often cut them by hand — especially if there aren't a lot of them. In addition to a few simple hand tools, this takes some practice (and some patience). But the satisfaction of fitting together a hand-cut dovetail is worth the effort.

**PINS AND TAILS.** Basically, a dovetail joint has two parts: the pins and the tails, see Drawing below left. What gives the joint its strength is the *sides* of the pins and tails are cut at opposing angles. To take advantage of this, the idea is to locate the pins on the part of the project that gets the most stress, see box below.

**ANGLE.** Although the exact angle of the pins and tails isn't critical, there is a simple rule of thumb. Traditionally, an angle that's based on an 8:1 ratio is used when working with hardwoods, see margin at left. And for softwoods, a 6:1 ratio is used.

**SIZE AND SPACING.** Once you establish the angle, you'll need to decide on the size and spacing of the pins and tails. I make all the



pins the same width — even the end pins that are angled on only one side, see Drawing below left.

But to avoid a “cookie cutter” look, I lay out the tails so they're anywhere from four to six times wider than the pins. With this in mind, you can either make all the tails the same width. Or vary the width as shown in the photo above.

**THREE STEPS.** Regardless of the size and spacing, there are three basic steps to cutting a dovetail by hand: laying out the joint, removing the waste, and fitting the parts together.

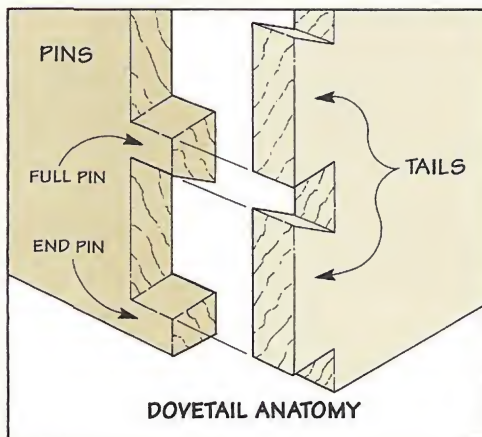
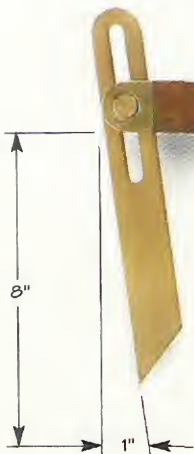

**Interlocking Parts.** Because the sides of the narrow pins are cut at opposing angles to the sides of the wide tails, the parts form a strong, interlocking joint.

## Locating Pins and Tails

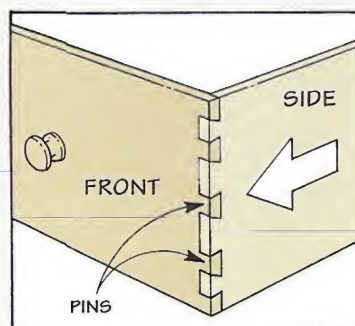

**Drawer.** Cut pins on the front of a drawer so they wedge against the tails on the side pieces when you pull open the drawer.

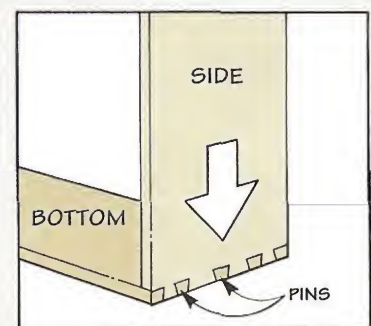

**Cabinet.** To support the weight of a cabinet (and its contents), locate pins on the bottom (and top) and tails on the sides.

# Layout

As with any joint, one of the keys to a tight-fitting dovetail is an accurate layout.

To avoid confusion when laying out the joint (and cutting and fitting it later on), I start by marking each of the pieces, see Step 1.

**SHOULDER LINES.** Since the pins and tails extend all the way through the adjoining piece, the next step is to draw a shoulder line, see Step 2. These lines indi-

cate the thickness of the adjoining piece. And they let you know how far down to cut the pins and tails.

Using the shoulder lines (and the rest of the layout lines) to make accurate cuts depends on the *thickness* of the pencil line. So I use a mechanical pencil to make crisp lines that are easy to see.

**TAILS AND PINS.** Now it's just a matter of laying out the tails and pins. After marking the wide



part of the tails on the end of the workpiece (Step 3), you'll need to transfer these lines to the pin piece with a try square, see Step 4. Then use a bevel gauge to mark the tails and pins, see Steps 5 and 6.

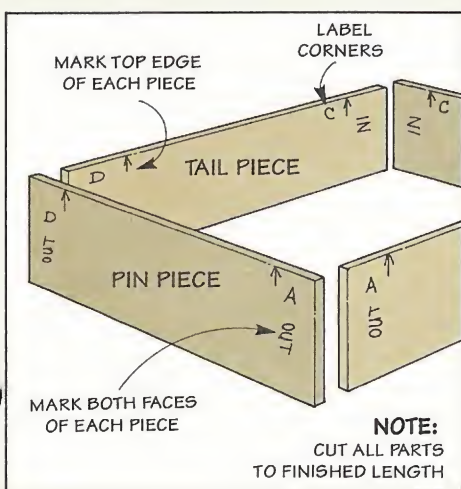

**Step 1.** After arranging the pieces on edge like they'll appear in the final project, mark the top edge, adjoining corners, and both faces of each piece.

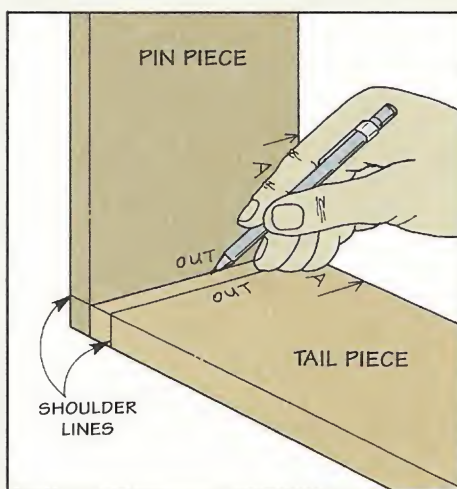

**Step 2.** A shoulder line drawn around all four sides of each piece serves as a reference to indicate how deep you'll need to cut the pins and tails.

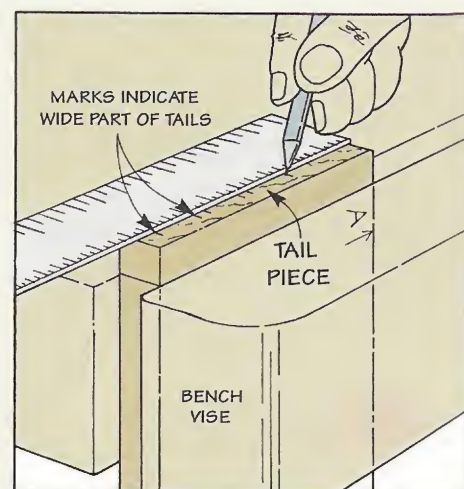

**Step 3.** The tail piece is tightened in a vise. Then a metal rule and mechanical pencil are used to mark the wide part of the tails on the end of the workpiece.

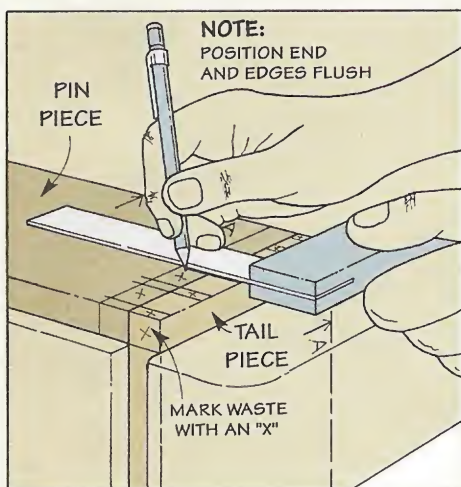

**Step 4.** With the pin piece held tight against the tail piece, draw layout lines across both pieces simultaneously. Then mark the waste sections with an 'x.'

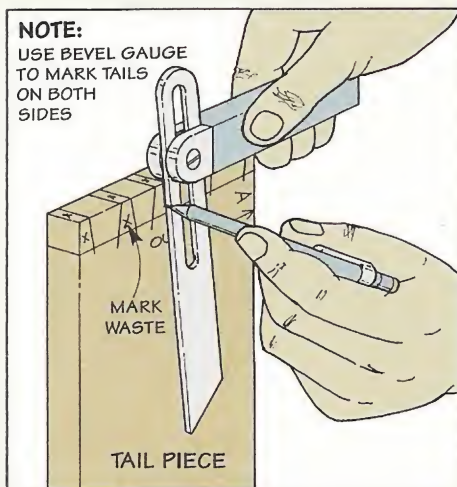

**Step 5.** Next, using a bevel gauge set to the desired angle (8:1 or 6:1), draw lines to indicate the sides of the tails on both faces of the workpiece.

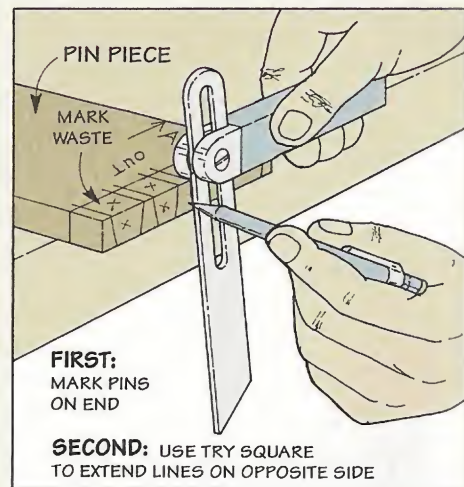

**Step 6.** To lay out the pins, draw angled lines across the end of the piece. Then use a try square to continue the lines on the opposite side of the workpiece.

# Remove the Waste

After laying out the joint, the next step is to remove the waste between the pins and the tails.

What I've found works best is to remove the bulk of this material with a saw. I use a fine-toothed hand saw to define the sides, see Steps 1 and 3. And a coping saw to remove the waste, see Step 2.

**LEAVE LINE.** To avoid removing too much material, it's important to cut on the *waste* side and

"leave" the pencil line, see photo. And to keep from cutting too deep, I clamp a hardwood block across the back shoulder line, see Step 1.

**SHOULDERS.** Once the waste is removed, I use a sharp chisel to establish the shoulders, see Step 4. Then, to produce a tight fit, make a slight V-shaped undercut.

The problem is if you undercut the openings for the *end* pins on the tail piece, it will create a gap when

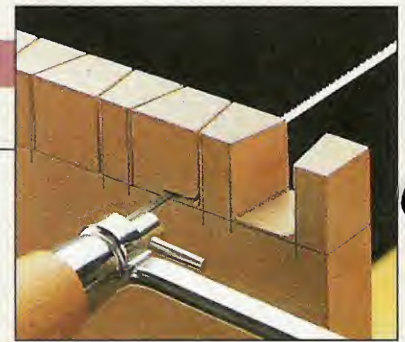

the joint is assembled. So the bottoms of these openings are pared flat, see Step 5.

Finally, it's just a matter of trimming the sides of the pins and tails up to the layout lines, see Step 6.

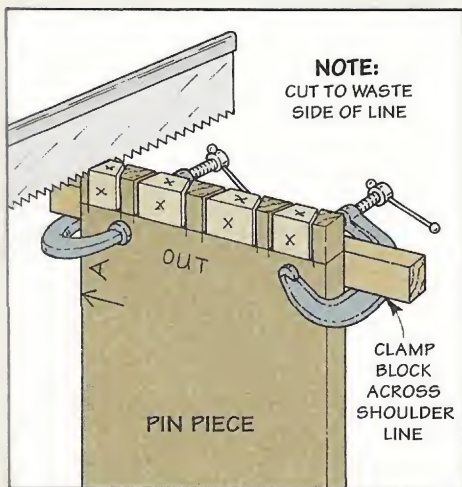

**Step 1.** The sides of the pins are formed by cutting to the waste side of the line. Stop when you see the kerf in a block clamped across the back shoulder line.

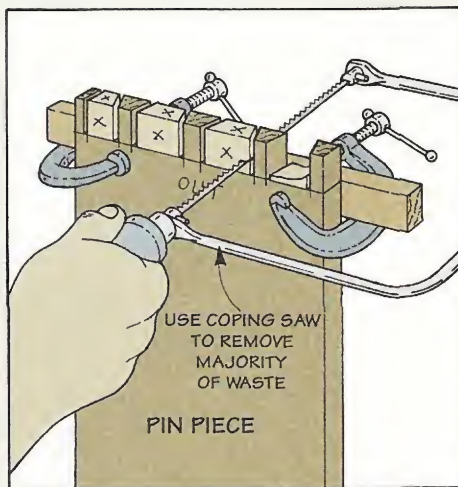

**Step 2.** After slipping the blade of a coping saw down one kerf, cut across the waste. Here again, stay to the waste side of the shoulder line.

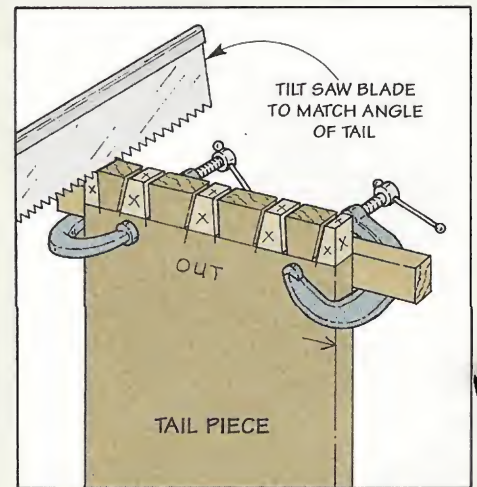

**Step 3.** To form the sides of the tails, tilt the saw blade at a slight angle and cut down to the shoulder line. Then remove the waste with a coping saw as before.

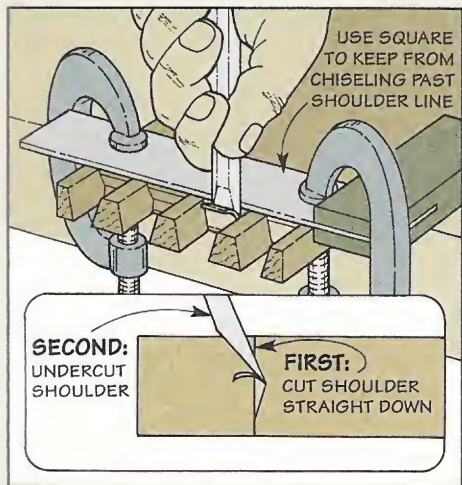

**Step 4.** With a square clamped across the shoulder line, make a shallow cut straight down. Then make a V-shaped undercut in the bottom of the opening.

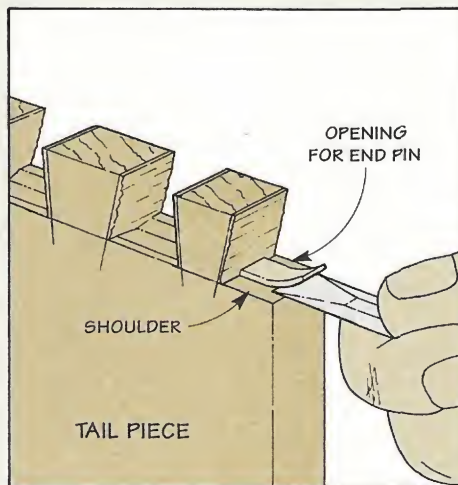

**Step 5.** To produce a tight fit, the openings for the end pins on the tail piece aren't undercut. Instead, they're pared flat with the shoulders already established.

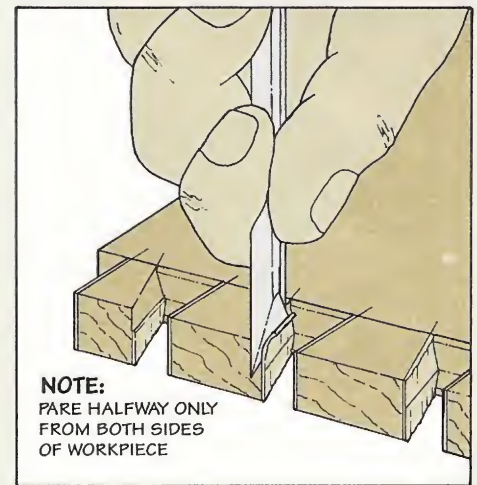

**Step 6.** Finally, trim the sides of the tails (and pins) up to the layout lines. To prevent chipout, pare halfway down from both sides of the workpiece.



# Fitting the Joint

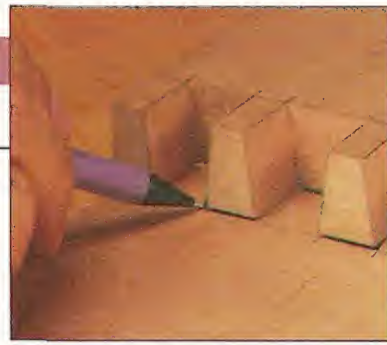

When it comes to fitting a dovetail, there's a bit of a catch. You'd like to assemble the joint to see how much needs to be trimmed off. But it won't go together if there's still some material that needs to be removed.

So how do you know just how much to take off? The secret is to first check that the pins fit the openings on the *outside* face of the tail piece, see photo and Steps 1 and

2. Then repeat the process on the *inside* face, see Steps 3 and 4.

**TRIMMING.** If you need to do some trimming, it's important you don't chisel through to the opposite side. This either removes material before you have a chance to check the fit. Or changes a fit you've already established.

**HOLLOW.** Next, I cut a shallow "hollow" in the sides of the pins, see Step 5. This makes the pieces go

together easier without affecting the fit. And it creates a pocket for the glue. Note: A bit of glue applied to the leading edges of the pins is all that's needed before assembling the joint, see Step 6.

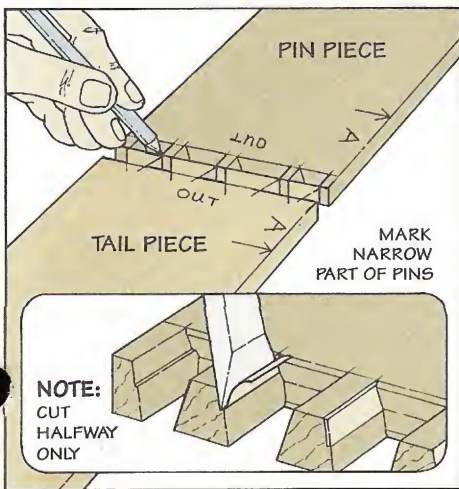

**Step 1.** First, check that the narrow part of the pins will fit the openings on the outside of the tail piece. After marking the pins, pare off the desired amount.

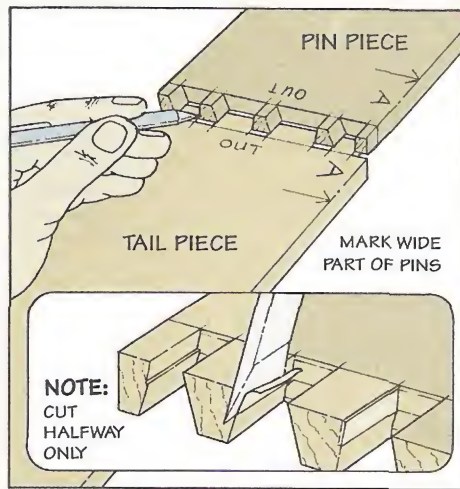

**Step 2.** Now hold the wide part of the pins above the wide part of the openings in the tail piece. Here again, mark the pins and trim off any excess.

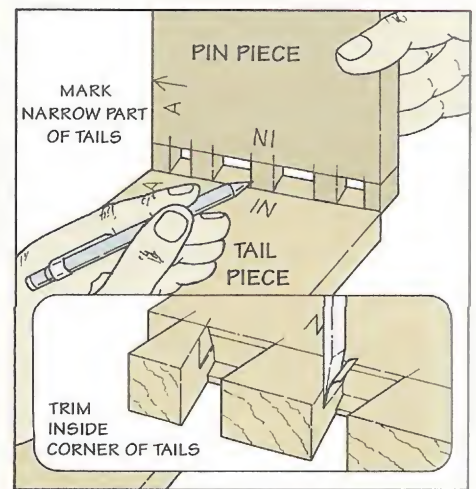

**Step 3.** Next, check that the wide part of the pins fits the openings on the inside face of the tail piece. Then mark the tails and trim as before.

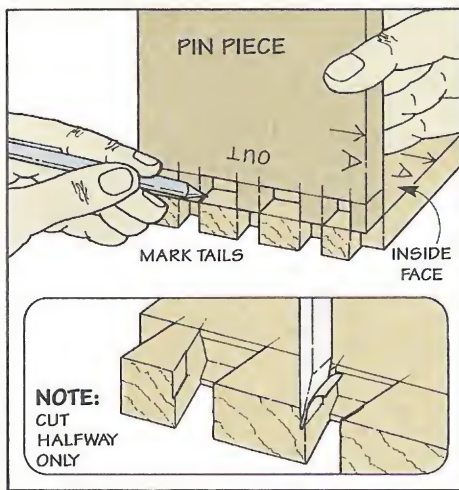

**Step 4.** If the narrow part of the pins won't fit the openings on the inside face of the tail piece, mark and trim the material on the tails that needs to be removed.

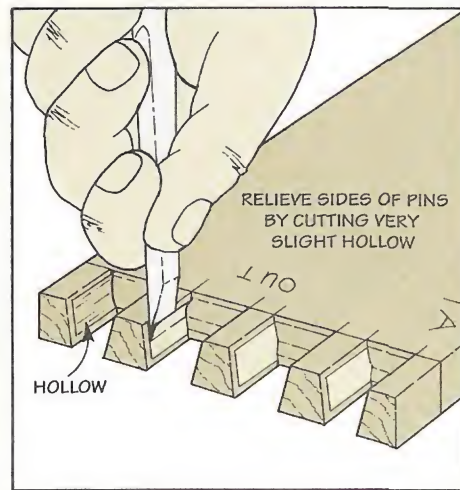

**Step 5.** To make the pieces fit tighter where it shows, scoop out a slight hollow on the sides of the pins. Just be careful not to cut the edges of the pins.

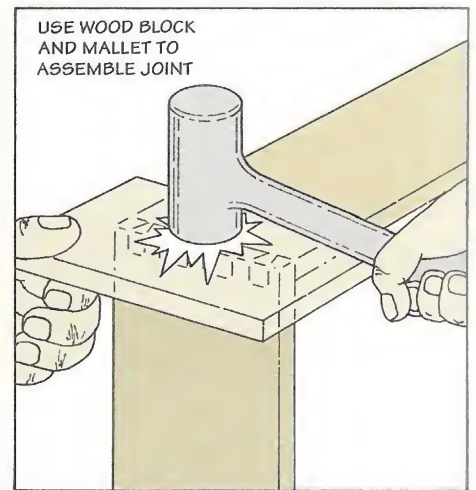

**Step 6.** After applying a small amount of glue to the leading edges of the pins, use a wood block and a mallet to drive the joint together.

# Dovetailed Bookcase

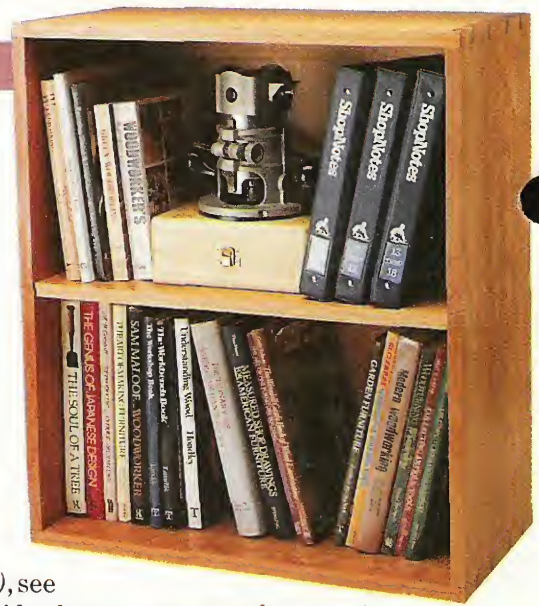

*The dovetail joints on this bookcase combine both strength and good looks.*

One of the challenges to building a bookcase that hangs on the wall is to make it strong enough to support a heavy load of books. To provide that kind of strength, there's one joint that's especially suited to the job — a dovetail.

But besides being strong, dovetail joints look good too. This combination of strength and good looks makes the bookcase an ideal project either for storing binders or manuals in the shop, see photo above. Or to hang in the house,

see photo below.

**CASE.** I began by building the case. It consists of two sides (A) held together by a top and bottom piece (B), see Drawing below. To provide plenty of room for large manuals or oversize books, I glued up 12"-wide pieces from 3/4"-thick stock. (I used cherry.)

**LENGTH.** Since the two parts of the dovetails (the pins and tails) extend through the adjoining pieces, the case pieces can be

cut to the exact outside dimensions of the case.

**DOVETAILS.** The next step is to cut the dovetails. You could use a router and a template to do this. But since there aren't a lot of them, I cut the dovetails by hand.

The first thing to decide is which pieces get the pins and which ones get the tails. What you want to do is locate the pins on the pieces that carry the weight. This means that the pins are on the top and bottom, and the tails are on the side pieces.

**LAYOUT.** Now you're ready to lay out the pins and tails. To prevent the wide case pieces from cupping, I located the pins closer together at the ends than the middle, see Dovetail Layout at left.

Note: For step-by-step instructions on laying out and cut-

**EXPLODED VIEW**  
OVERALL DIMENSIONS:  
12" D x 24" W x 27 1/2" H

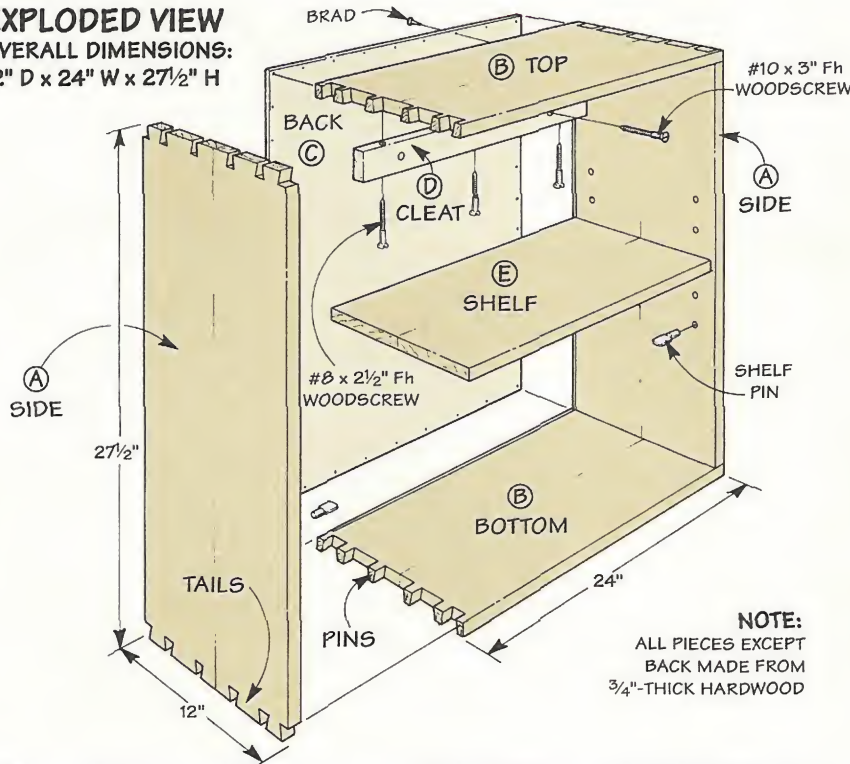

**NOTE:**  
ALL PIECES EXCEPT  
BACK MADE FROM  
3/4"-THICK HARDWOOD

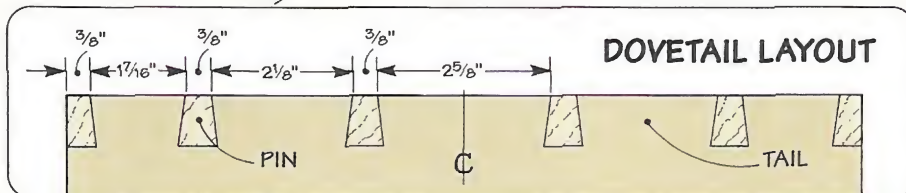

▲ Simple design and strong dovetail joints make this bookcase an ideal project for the house as well.

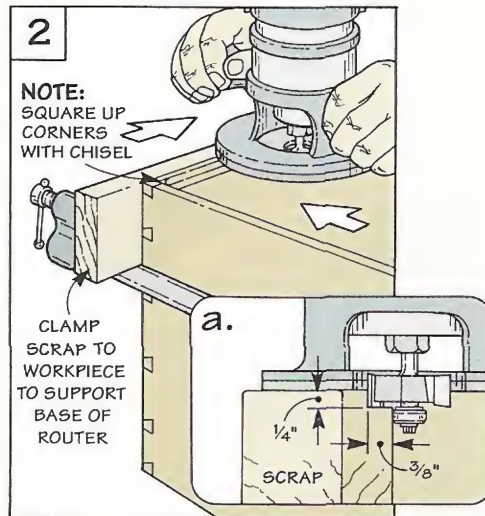
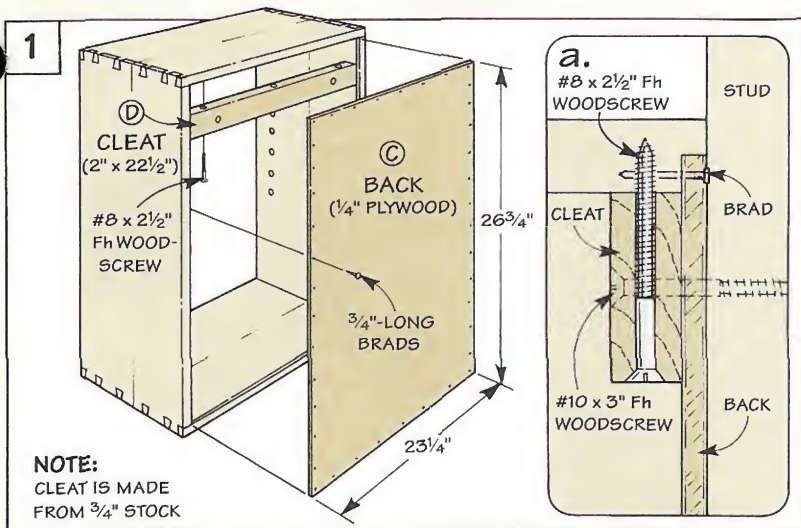

ting dovetails, refer to page 22.

**BACK.** After fitting the case together, the next step is to add a plywood back, see Fig. 1. The back (C) fits in a rabbet that's routed in the back edges of the case, see Fig. 2a. To provide support for the base and prevent the router from tipping, I clamped scrap pieces of wood to the case, see Fig. 2.

**CLEAT.** Before attaching the back, I added a hardwood cleat (D) to provide a way to secure the bookcase to the wall, see Fig. 1. After cutting the cleat to fit inside the case, it's glued and screwed to the top piece so it's flush with the back edge of the rabbet, see Fig. 1a.

Once the cleat is installed, it's just a matter of cutting the back (C) to fit the case and attaching it with glue and 3/4"-long brads.

**SHELF.** All that's left to complete the bookcase is to add the shelf (E), refer to Fig. 4. Here again, the shelf is glued up from 3/4"-thick stock. To make it easy to slip in the case, I allowed 1/16" of clearance on each end (1/8" overall).

**PINS.** The shelf is supported by four pins that fit in a series of holes drilled in both sides of the bookcase. To make sure all the holes align, I use a simple template, see Fig. 3.

This is a scrap of 3/4"-thick

stock that's cut to fit inside the bookcase. Holes drilled in the template automatically locate the holes for the shelf pins an equal distance from the bottom.

**FINISH.** Finally, to protect the surface of the bookcase, I applied three coats of a wiping varnish.

After it cures, the bookcase can be attached to the wall by drilling holes through the cleat and back and running screws into the wall, see Fig. 1a.

Note: Because of the weight of the bookcase, it's important to hit studs when screwing it in place.

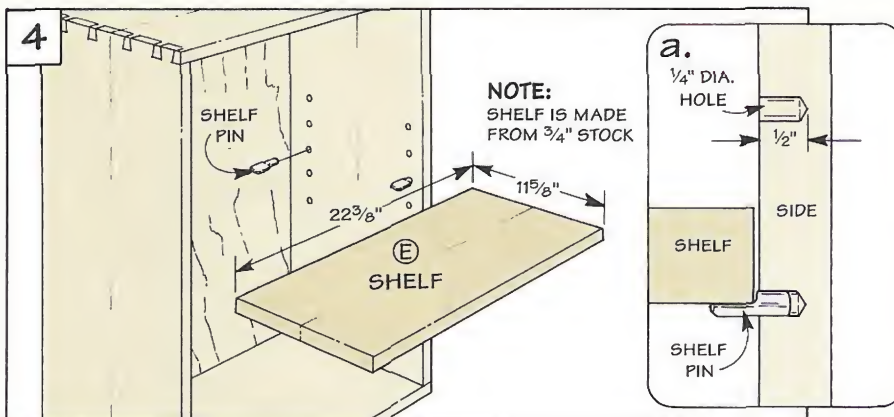
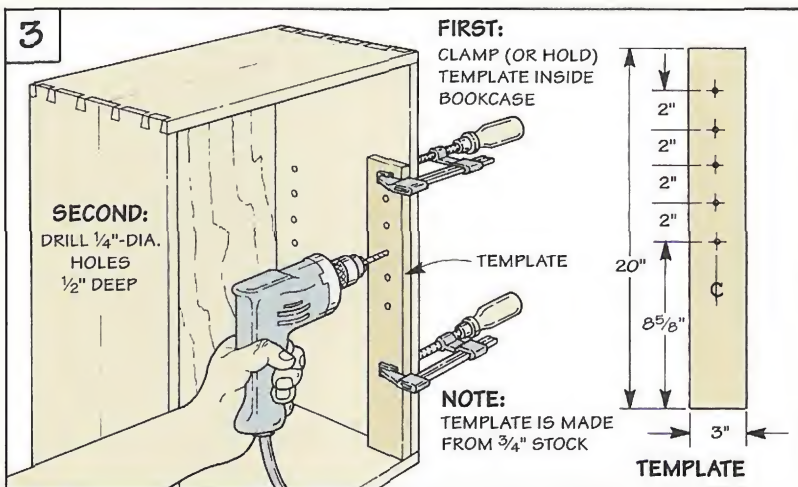

# Shop Solutions

## Mortising Jig

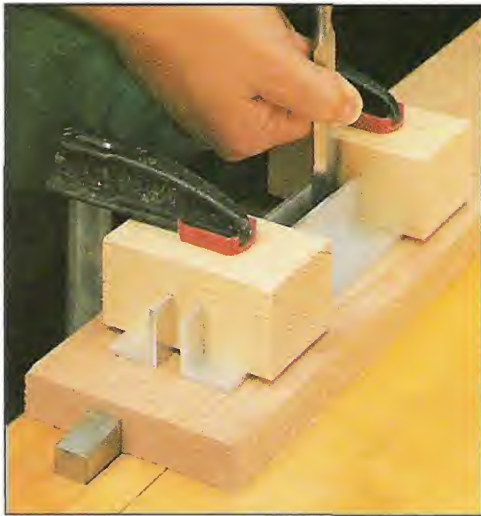

Like many woodworkers, I cut mortises by first drilling out most of the waste. Then clean up the sides with a chisel. But it's difficult to get the sides square with the face. To solve this, I made a simple jig to guide the chisel.

The jig consists of a pair of aluminum angle pieces to guide the chisel. And two wooden brackets that space the aluminum angle to match the width of the mortise. By clamping the top of the brackets, both the jig and workpiece are held in place, see photo.

To position the jig accurately

on the mortise, I use a couple of dowels (the same width as the mortise) as index pins. They fit in the holes drilled at each end of the mortise, see Fig. 1.

To use the jig, butt the aluminum angle against the dowels on both sides, see Fig. 1. Now all you have to do is cut a pair of kerfs in each bracket and slip it over the angle, see Fig. 2.

Finally, clamp each bracket and remove the dowels before you begin to chisel, see Fig. 2a.

*Peter Palker*

*Jeffersonville, Vermont*

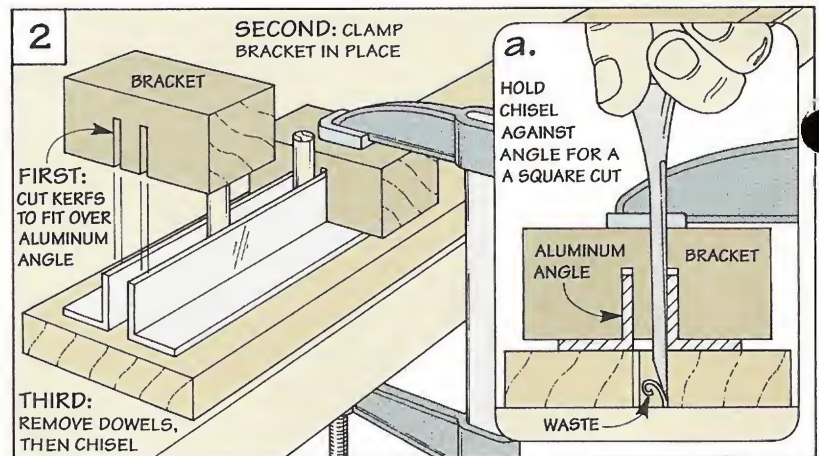
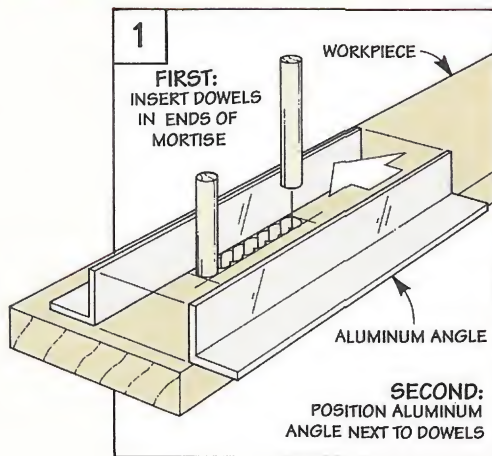

## Circle Cutter Gauge

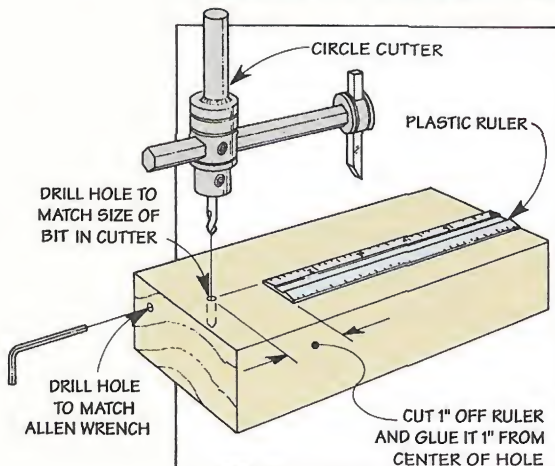

The problem with circle cutters is it's just about impossible to get them set to the right diameter. The scale stamped on the arm of the cutter is never accurate. And trying to measure from the center of the drill bit to the cutter tip is awkward at best.

To avoid making trial and error cuts when setting up the cutter, I made a simple gauge to accurately set the hole diameter.

It's made from a scrap piece of 2x4, see Drawing. I drilled a hole

on one face the same size as the drill bit on the circle cutter. And glued a plastic ruler 1" out from the centerline of the hole.

To use the gauge, insert the drill bit on the cutter in the hole. Then adjust the cutter for the length of the radius you need.

Note: Since I'm always losing the Allen wrench that adjusts the cutter, I drilled a hole in one end to store the wrench.

*David Berg*

*Columbia, Missouri*

## Quick Bench Vise

■ Since I don't have a vise on my workbench, holding boards on edge was a real challenge. Until I came up with an inexpensive solution that uses clamps I already have. All I do is attach shop-made clamping brackets to the side of my bench, see Drawing.

These clamping brackets are nothing more than L-shaped blocks of wood screwed to the side of my bench, see Drawing. I added metal supports to the bottoms that pivot out and hold a board on edge. Just set a board on the supports and clamp it in place.

*Arne Sax  
Hubbell, Michigan*

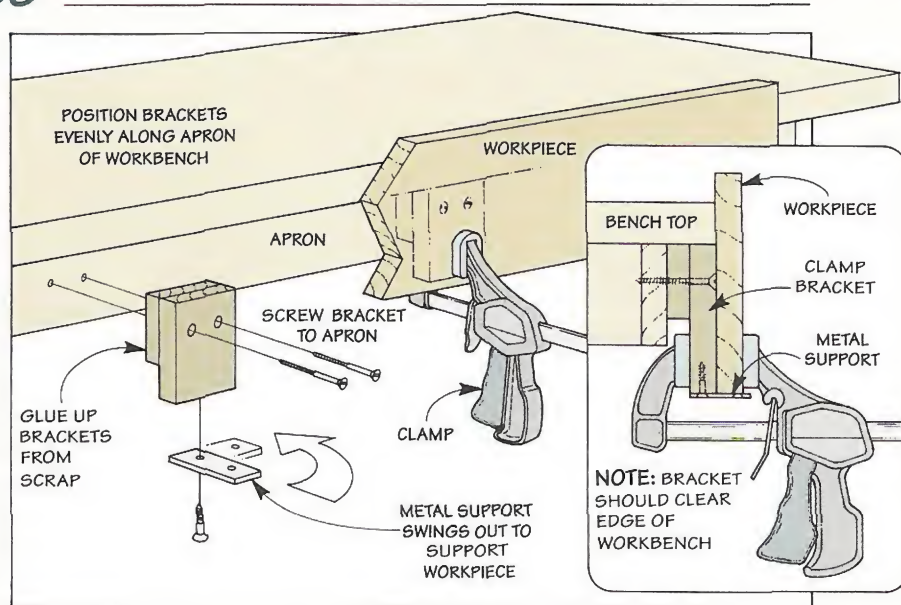

## Perfect Dados

■ Setting up a dado blade to cut a dado or groove to match plywood can be a hassle. One way is to add and remove shims.

Instead of shims, I use a narrower blade and make two passes. But I don't move the rip fence between passes — I use a spacer to make up the difference, see Drawing.

The advantage to this is you can quickly cut a scrap wood spacer to the correct thickness. This produces tight fitting dados and grooves every time.

*Dean Curtis  
Scottsdale, Arizona*

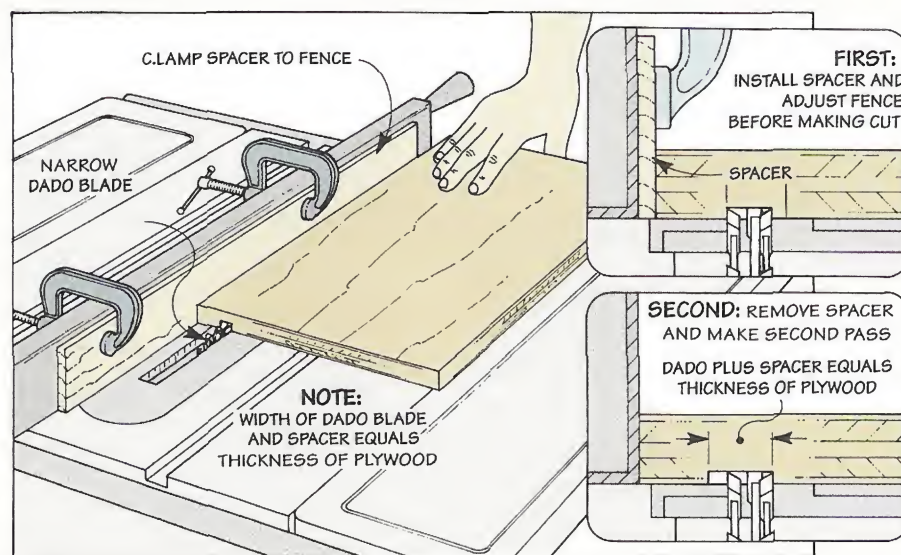

## Quick Tip



■ Here's an easy solution for clamping odd-shaped projects. Buy electrical cable ties at your local hardware store, see photo.

Cable ties are inexpensive, don't mar the wood, and apply just the right amount of clamping pressure. Plus, they can be joined together to clamp larger pieces.

*Will Noonan  
San Francisco, California*

## Send in Your Solutions

If you'd like to share your original solutions to problems you've faced, send them to: *ShopNotes*, Attn: Shop Solutions, 2200 Grand Avenue, Des Moines, IA 50312. (Or if it's easier, FAX them to us at: 515-282-6741.)

We'll pay up to \$200 depending on the published length. Please include a daytime phone number so we can call you if we have questions.

# Wood Filler

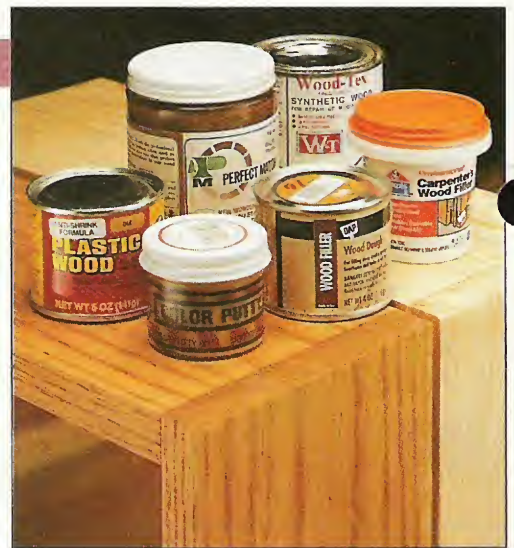

*Recently, I stopped by a local home improvement center to pick up wood filler for a project. I was overwhelmed by the number of choices. Which filler do you use?*

*Bob Otto  
Sheboygan, Wisconsin*

match colors. Because *Color Putty* comes in 17 different shades, it's easy to match it to a project that has been stained — which makes the filled areas nearly invisible.

**CUSTOM MIX.** Another advantage to *Color Putty* is you can custom mix your own color if you can't find exactly what you're looking for. To do this, just knead together a pinch or two from the colors you think will blend to produce the color you're after.

**NO WAITING.** Also, since this type of filler doesn't harden, you don't have to wait overnight to apply the topcoat of finish. Once the hole is filled, the finish can be applied immediately.

The final finish coat over a non-drying filler is important. It seals the filler in the hole and provides a continuous hard surface.

**SHELF LIFE.** Another thing I like about this type of filler is its long shelf life. It doesn't harden in the container. And if it ever does get too dry to work, all you have to do to soften it up is add a

few drops of boiled linseed oil or mineral spirits.

## HARDENING FILLER

But we do use hardening fillers too. They're perfect when we have a hole, a gap, or a knot that's too large or deep for the soft non-hardening filler. Or whenever a project is going to be painted.

When using a hardening filler, I'll fill the holes before sanding the project. Then wait overnight to allow the filler to dry, and sand the wood and filler smooth.

**STAIN PROBLEMS.** The biggest drawback to hardening fillers is they don't accept stain like wood does. When stained, these fillers tend to stand out from the surrounding wood.

But regardless of the filler you use, it's a good idea to first test it on a piece of scrap wood that's finished the same way as your project. This way, you won't have any surprises later.

*We use two types of wood filler for two different reasons.*

■ In our shop, we use two different types of filler: non-hardening and hardening. The type we use depends on what we need to fill and the finish we're using.

If the project is going to be stained, we'll fill nail holes and gaps with a non-hardening filler such as *Color Putty* (see Sources on page 31).

But if it's a project that's going to have a natural or painted finish, or the hole being filled is large, we'll use a hardening filler such as *Wood Dough* (DAP) or *Plastic Wood* (Boyle-Midway).

Each type of filler has its own advantages and disadvantages.

## NON-HARDENING FILLER

The advantage to the non-hardening filler we use is it's easy to



**Non-Hardening.** This type of filler is applied directly to a stained project. The finish can follow immediately.



**Hardening.** A hardening filler is used on projects with a natural or painted finish. After



filling all the holes and gaps, allow it to dry overnight before sanding and finishing.

# Sources

*ShopNotes Project Supplies* is offering some of the hardware and supplies needed for the projects in this issue. We've also put together a list of other mail order sources that have the same or similar hardware and supplies.

## SPIRAL END MILL BITS

To produce a clean cut when using the Drawer Joint Jig shown on page 4, it's best to use a 1/4" spiral end mill bit.

We recommend using a solid carbide spiral end mill bit rather than a high-speed steel bit because it stays sharp longer. These bits are available at most woodworking stores and some of the mail order sources listed below.

## RESAWING

The article on page 12 provides tips and techniques for resawing on a band saw (making thin stock out of thick boards).

If you're doing a lot of resawing, we recommend using a wide (1/2") hook tooth blade. These blades cut fast. And the deep gullets between each tooth clear chips quickly and efficiently.

While there are a number of different brands, we've had good

results using *Lenox* saw blades. *Lenox* and other band saw blades are available through woodworking stores and some of the mail order sources listed below.

## DRILL PRESS TABLE

The Drill Press Table and Fence shown on page 16 provides a quick way to make accurate setups on the drill press.

One reason is the table is larger, so it's easy to support large workpieces. And the fence is micro-adjustable for precise setups. Once it's in position, you can lock the fence in place with one hand.

*ShopNotes Project Supplies* is offering a kit for the Drill Press Table and Fence. It includes all the hardware to build the project. All that you have to supply is 3/4"-thick Medium Density Fiberboard (or plywood) and 1/4"-thick Masonite.

**\$18-6818-100** Drill Press Table and Fence Kit..... \$16.95

## HAND-CUT DOVETAILS

There's a step-by-step approach to cutting dovetails by hand in the article shown on page 22. When using this technique, you'll need a few hand tools for laying out the joint, removing the waste,

and fitting the pins and tails.

Besides a metal rule, all you need to lay out the joint is a try square and bevel gauge. Once you've laid out the pins and tails, we recommend using a fine-toothed (15 to 16 teeth per inch) hand saw to define the sides. Then remove the waste with a coping saw. Finally, you'll need a set of beveled-edge chisels to sneak up on a perfect fit.

You can find these hand tools at most woodworking stores and many of the catalogs in the mail order sources listed below.

## WOOD FILLER

The article on the opposite page takes a close look at wood fillers. Basically, there are two types: non-hardening and hardening.

To fill small gaps, we use a non-hardening filler called *Color Putty*. It's applied *after* a stain is applied and before the topcoat.

But if the project is going to be painted (or if the area to be filled is larger), a hardening filler works best. These are available under brand names like *Plastic Wood*, *Wood Dough*, and *Wood-Tex*. Both types of filler are available at most hardware stores.

## MAIL ORDER SOURCES

Similar hardware and supplies may be found in the following catalogs. Please call each company for a catalog or for ordering information.

**American Saw & Mfg. Company**  
800-628-3030  
*Lenox Band Saw Blades*

**Garrett Wade**  
800-221-2942  
*Layout Tools, Hand Saws, Chisels*

**Highland Hardware**  
800-241-6748  
*Layout Tools, Hand Saws, Chisels, Spiral End Mill Bits*

**Iowa Machinery**  
515-288-0123  
*Lenox Band Saw Blades*

**Robert Larson Co.**  
800-356-2195  
*Layout Tools, Hand Saws, Chisels*

**Trendlines**  
800-767-9999  
*Band Saw Blades, Layout Tools, Chisels, Spiral End Mill Bits*

**Woodcraft**  
800-225-1153  
*Layout Tools, Hand Saws, Chisels, Spiral End Mill Bits*

**Woodworkers' Store**  
800-279-4441  
*Layout Tools, Hand Saws, Chisels*

**Woodworker's Supply**  
800-645-9292  
*Band Saw Blades, Layout Tools, Chisels, Hand Saws*

## ORDER INFORMATION

### BY MAIL

To order by mail, use the order form that comes with the current issue. The order form includes information on handling and shipping charges, and sales tax.

If the mail order form is not available, please call the toll free number at the right for more information on specific charges and any applicable sales tax.

### BY PHONE

For fastest service, use our toll free order line. Open Monday through Friday, 7:00 AM to 7:00 PM Central Time.

Before calling, please have your VISA, MasterCard, or Discover Card ready.

**1-800-444-7527**

*Note: Prices subject to change after January 1, 1995.*

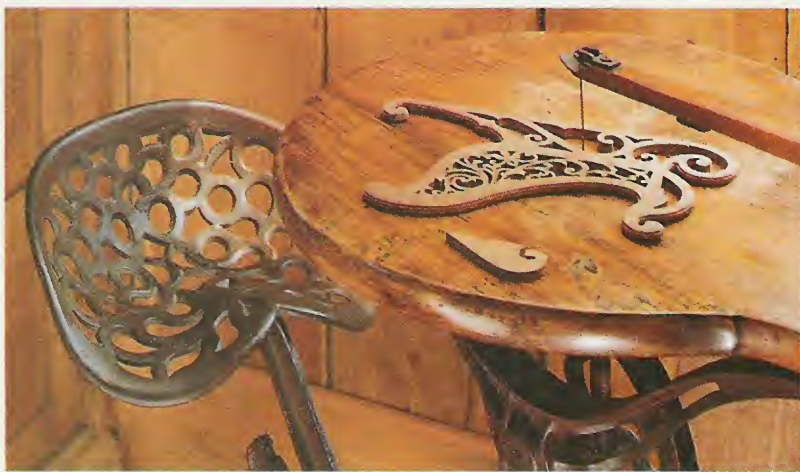

## Scenes From the Shop

*The Barnes Velocipede No. 2 scroll saw shown above was often used to cut delicate fretwork. But it's also capable of cutting stock up to 3 inches thick at a rate of*

*1 foot per minute. Varying the speed is simply a matter of pedaling faster or slower. And the seat can be adjusted up or down for surprisingly comfortable sawing.*