

# ShopNotes®

Vol. 4

Issue 19

## MODULAR CLAMP STORAGE SYSTEM

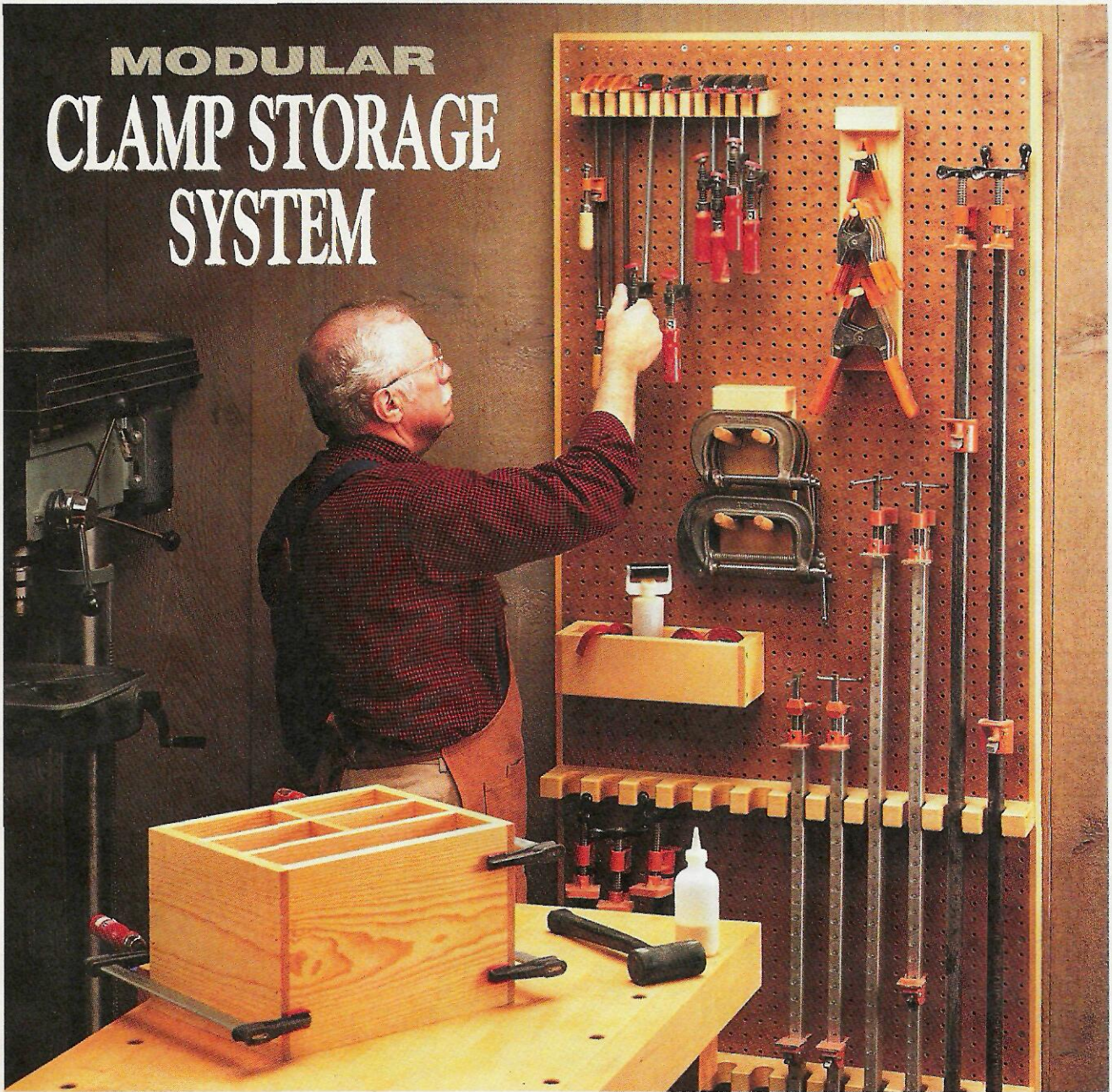

- Built-Up Moldings
- Selecting Circular Saws
- Hand Plane Jointer
- Hand-Held Routing Tips





# ShopNotes

Issue 19 January 1995

- EDITOR** Donald B. Peschke  
**EXECUTIVE EDITOR** Douglas L. Hicks  
**MANAGING EDITOR** Richard S. Peters  
**ASSOCIATE EDITOR** Tim Robertson  
**ASSISTANT EDITOR** Phil Totten  
**CONTRIBUTING EDITOR** Mark A. Williams
- CREATIVE DIRECTOR** Ted Kralicek  
**ART DIRECTOR** Cary Christensen  
**SENIOR ILLUSTRATOR** Kurt Schultz  
**ILLUSTRATORS** Will Niskanen  
 Roger Reiland  
 Mark Higdon  
**PHOTOGRAPHER** Crayola England
- DESIGN DIRECTOR** Ken Munkel  
**SENIOR DESIGNER** Kent Welsh  
**SHOP MANAGER** Steve Curtis  
**SHOP ASST./FACILITIES** Steve Johnson

#### CIRCULATION

Circulation Director: Liz Bredeson • Subscription Manager: Phyllis Jessen • Direct Mail Mgr.: Troy Dowell • Newsstand Sales: Kent A. Buckton

#### PUBLISHING SERVICES

Manager: Gordon C. Gaippe • Graphic Artist: Cheryl L. Cynor

#### CORPORATE SERVICES

Planning Director: Jon Macarthy • Controller: Robin Hutchinson • Accounting: Laura Thomas • Bookkeeping: Julie Greenlee • Prod. Manager: Carol Quijano • Info. Services Mgr.: Joyce Moore • Elect. Pub. Coordinator: Douglas M. Lidster • Application Specialist: Linda Morrow • Support Assistant: Nick Thielen • Administrative Assistants: Cheryl Scott, Julia Fish • Receptionist: Jeanne Johnson • Building Maint.: Ken Griffith

#### PROJECT SUPPLIES

Art Director: Cindy Jackson • Catalog Products Manager: Bob Baker • Inventory Control/Prod. Manager: Mark Mattussi • Project Supplies: Linda Jones • Technical Support: Jeff Janes

#### CUSTOMER SERVICE

Supervisor: Jennie Enos • Customer Service Reps.: Jennifer Murphy, Joy Krause, Sara Kono, Anna Cox, Lonnie Algreen, Karla Cronin

#### SHIPPING DEPARTMENT

Supervisor: Nancy Johnson • Fulfillment: Gloria Sheehan, Chuck Carlson, Sylvia Carey, Larry Prine

ShopNotes © (ISSN 1062-9696) is published bimonthly (Jan., March, May, July, Sept., Nov.) by Woodsmith Corporation, 2200 Grand Ave., Des Moines, IA 50312.

ShopNotes ® is a registered trademark of Woodsmith Corp. © Copyright 1995 by Woodsmith Corporation. All rights reserved.

Subscriptions: Single Copy, \$4.95. One year subscription (6 issues), \$19.95. Two years (12 issues), \$35.95. Canada/Foreign, add \$5.00 per year.

Second Class Postage Paid at Des Moines, IA and at additional offices.

Postmaster: Send change of address to ShopNotes, Box 11204, Des Moines, IA 50340-1204

Subscription Questions? Call 1-800-333-5854, 9am to 5pm, Central Time, weekdays.

E-Mail: Prodigy: EDJE97A, CompuServe: 75330,2301, Internet: 75330.2301@compuserve.com, American Online: Donpeschke.

## EDITOR'S NOTE

# Cutoffs

One of the things I enjoy most about woodworking is the optimism of woodworkers — their attitude and enthusiasm. Whether I talk to someone in person, on the phone, through the mail, or via electronic mail, they're usually excited about some new idea or technique.

They're also always looking for a way to improve something — their shop, a project, or a finish. Along with this come lots of suggestions. "Hey Don, how about? Or have you ever considered? And I sure would like to see. . ."

**IMPROVEMENTS.** It's no different when you get a bunch of woodworkers together to publish a magazine. This desire for improvement is just as strong.

In this issue, you'll find a number of improvements. Nothing drastic. Just things you've been asking for — like more tips, a special department for the small shop, the Lumberyard, and the Finish Room in every issue.

We've also included two new regular features. We're calling the first feature a Hands-On Project because it uses one of the techniques in the issue. It's just a

quick project to give you a "taste" of a new technique. In this issue, there's a simple Wall Mirror. It's based on the built-up molding article shown on page 12.

**SELECTING TOOLS.** The second new feature is Selecting Tools. We've set out to write articles that will help you select the right tool for your needs. But with two important differences from the "tool reviews" you're likely to find in other magazines.

First, we don't receive any of the tools as gifts. We buy them at full price just as you would. This way we don't owe anyone any favors.

This also assures us of getting a regular production model and not a tool specially prepared by the manufacturer. The end result is an honest, unbiased look at each tool. (In this issue, we feature circular saws, see page 8.)

And second, instead of providing a single viewpoint, we've carefully selected a team of testers with a wide range of skills — so that you can easily identify with one of them.

I'm excited about these new improvements. Let me know what you think.

#### STATEMENT OF OWNERSHIP, MANAGEMENT AND CIRCULATION

(Required by 39 U.S.C. 3685)

1. Title of Publication: ShopNotes. 1a. Publication No.: 10629696. 2. Date of Filing: September 21, 1994. 3. Frequency of issue: Bimonthly. 3a. No. of issues published annually: 6 (six). 3b. Annual subscription price: \$19.95. 4. Complete mailing address of known office of publication: 2200 Grand Avenue, Des Moines, (Polk County), Iowa 50312-5306. 5. Complete mailing address of the headquarters of general business offices of the publisher: 2200 Grand Avenue, Des Moines, Iowa 50312-5306. 6. Full names and complete mailing address of publisher, editor, and managing editor: Publisher and Editor: Donald B. Peschke, 2200 Grand Avenue, Des Moines, Iowa 50312; Managing Editor: Richard S. Peters, 2200 Grand Avenue, Des Moines, Iowa 50312. 7. Owner: Woodsmith Corporation, 2200 Grand Avenue, Des Moines, Iowa 50312; Donald B. Peschke, 2200 Grand Avenue, Des Moines, Iowa 50312. 8. Known bondholders, mortgagees, and other security holders owning 1 percent or more of total amount of bonds, mortgages or other securities: None. 9. (Does not apply.) 10. Extent and nature of circulation:

	Average no. copies each issue during preceding 12 months	Average no. copies of single issue published nearest to filing date
A. Total no. copies printed (net press run) . . . . .	274,829	240,970
B. Paid and/or requested circulation:		
1. Sales through dealers, street vendors and counter sales . . . . .	15,821	29,032
2. Mail subscriptions (paid and/or requested) . . . . .	228,932	199,697
C. Total paid and/or requested circulation . . . . .	244,753	228,729
D. Free distribution by mail, carrier or other means, samples, complimentary, and other free copies . . . . .	49	49
E. Total distribution . . . . .	244,802	228,778
F. Copies not distributed:		
1. Office use, left over, unaccounted, spoiled after printing . . . . .	15,254	9,017
2. Returns from news agents . . . . .	14,773	3,175
G. Total . . . . .	274,829	240,970
11. I certify that the statements made by me above are correct and complete. (signed) Donald B. Peschke, Publisher/Editor		



# Contents

## Projects & Techniques

### Hand Plane Jointer \_\_\_\_\_ 4

*This shop-built jig produces a straight, square edge on a workpiece by converting your hand plane into a jointer.*

### Built-up Moldings \_\_\_\_\_ 12

*A router and some ordinary bits. That's all it takes to build up your own detailed moldings.*

### Wall Mirror \_\_\_\_\_ 14

*Use our simple built-up molding technique to make this handsome wall mirror in just a few hours.*

### Cutting Guide \_\_\_\_\_ 16

*A unique tracking system on this cutting guide lets you use your circular saw or router to produce straight, accurate cuts.*

### Routing Profiles \_\_\_\_\_ 22

*Create decorative profiles that are smooth and consistent with a hand-held router and our step-by-step approach.*

## Departments

### Selecting Tools

### Circular Saws \_\_\_\_\_ 8

*Buying a circular saw? Our team tests eleven popular saws and offers practical suggestions on what to look for.*

### Great Tips

### Pipe Clamp Tips \_\_\_\_\_ 20

*From gluing up flat panels to keeping clamps from marring the work, here's a collection of our best pipe clamp tips.*

### The Small Shop

### Clamp Storage System \_\_\_\_\_ 24

*This convenient storage system organizes all of your clamps so they're right at hand where you need them.*

### Readers' Tips

### Shop Solutions \_\_\_\_\_ 28

*Our readers offer their own shop-tested solutions to common woodworking problems. Plus two quick tips.*

### Lumberyard

### Lumber Grain \_\_\_\_\_ 30

*There's more to lumber grain than appearance. It also affects the stability and cost of a project.*

### Finish Room

### Danish Oil \_\_\_\_\_ 31

*A natural-looking finish that's easy to apply. And you can repair it too. All this makes Danish oil worth a closer look.*

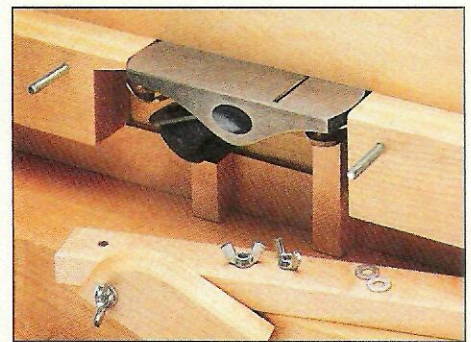

Hand Plane Jointer page 4



Circular Saws page 8

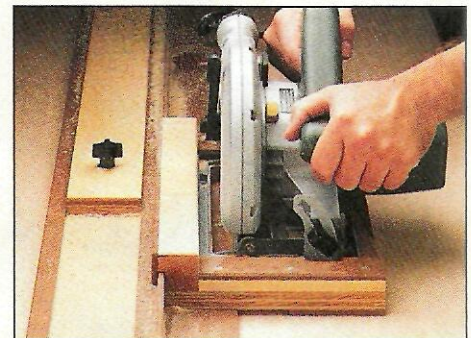

Cutting Guide page 16

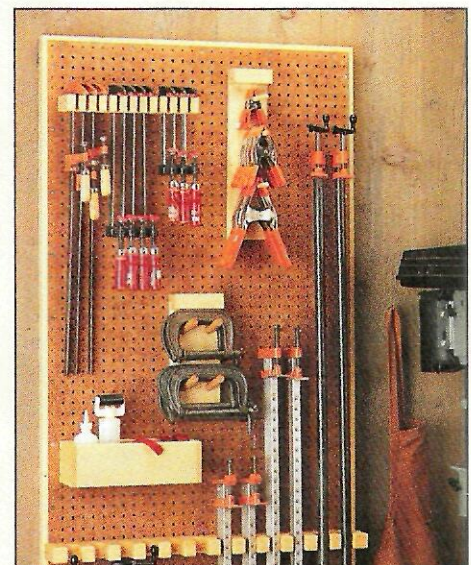

Clamp Storage System page 24



# Hand Plane Jointer

*All it takes to get a perfectly square edge is a small hand plane and this shop-built jointer.*

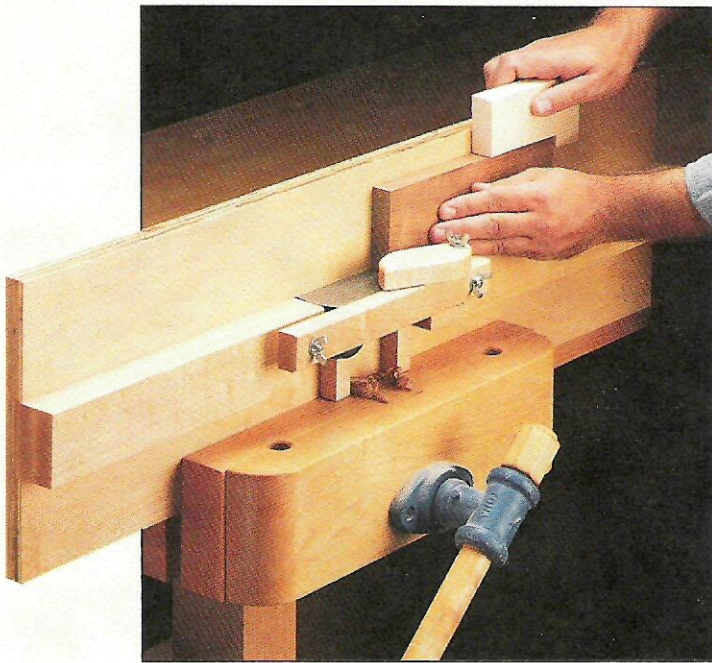

**R**ecently, one of the small hand planes in our shop turned up missing. But even more mysterious than its disappearance was the place it showed up — in this shop-made jointer, see photo.

It seems that one of the guys was looking for a way to get a straight, square edge on some pieces that were too small to plane by hand. Or pass safely across the power jointer. So he built a “holder” for the plane that works like a jointer.

With two wood tables for support, you simply run the work-

piece across the plane to produce a clean, crisp cut. As an added benefit, we found that the jointer worked just as well with large pieces, refer to page 7. So it's also an ideal project if you don't have a power jointer.

**FENCE.** The jointer starts off as a tall plywood fence (A), see Exploded View and Fig. 1. To secure the jointer, the bottom of the fence tightens in a vise. And the top supports the workpiece.

**GROOVE.** After cutting the fence to size, the next step is to cut a wide groove. In addition to accepting the two wood tables, the groove provides a recess for the plane. The thing to keep in mind

here is the *depth* of the groove.

Since the blade on a plane doesn't extend clear to its side, the groove lets you “bury” the blade below the surface of the fence, see Fig. 1a. This way, when the workpiece is held tight against the fence, the blade removes a shaving across the entire edge.

**TABLES.** Once the groove is cut, you can add the two tables. Like a power jointer, there's an infeed and an outfeed table to support the workpiece.

Before determining the length of these tables, you'll need to position the plane so the *blade* is centered on the length of the fence, see Fig. 1. Then the tables are built around the plane.

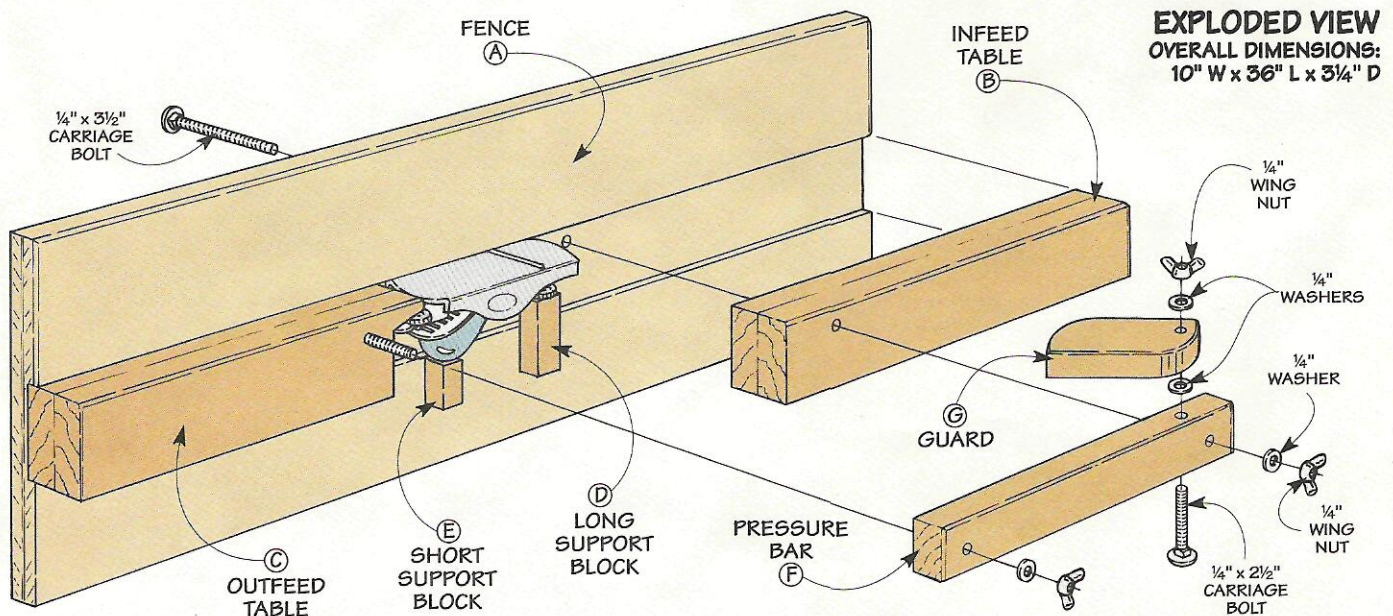

**EXPLODED VIEW**  
OVERALL DIMENSIONS:  
10" W x 36" L x 3 1/4" D



**BLANK.** The tables are made by gluing up two pieces of 3/4"-thick hardwood. (We used maple.) It's easiest to start with one long blank that's ripped to width to fit the groove, see Fig. 1.

To provide continuous support for the workpiece, the tables butt up against the ends of the plane. So with the plane in position, cut the *infeed* (B) and *outfeed table* (C) to match the distance from the ends of the fence to the plane.

**NOTCH.** Depending on the plane, you may need to notch the outfeed table to fit the adjusting mechanism. (The notch shown in Fig. 1b provides plenty of clearance for a standard size block plane.)

**CHAMFERS.** And to keep your hand from hitting a sharp corner if it slips off the workpiece when jointing a workpiece, chamfer the exposed edges on the tables and fence, see Fig. 1.

**ATTACH TABLES.** Now it's simply a matter of gluing the infeed table flush at the end. Then use the plane as a spacer and glue on the outfeed table.

**ADJUSTMENT SCREW.** To ensure that you end up with a square edge on the workpiece, you'll need to install an adjustment screw in the groove, see Figs. 2 and 2b. That's because the

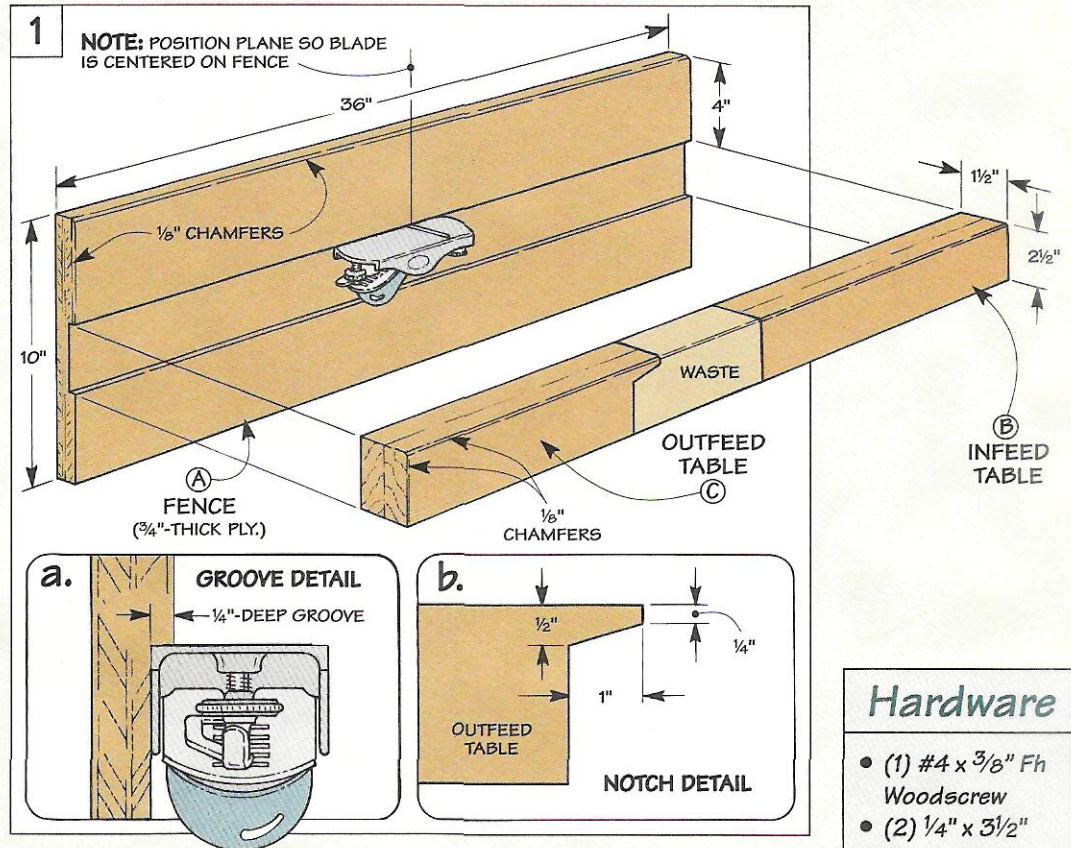

sides of a plane aren't necessarily 90° to the sole. The screw allows you to correct for this by tilting the body of the plane so the sole is 90° to the fence, see Fig. 2a.

**SUPPORT BLOCKS.** Next, we added two support blocks to keep the plane from falling out of the jointer. A *long block* (D) supports

the front knob of the plane. And a *short block* (E) fits under the cap.

To provide a stable work surface, the bottom ends of the support blocks rest on top of the vise when you tighten down the fence. So the blocks are cut to length and glued in place so the bottom ends are flush, see Fig. 2b.

**Hardware**

- (1) #4 x 3/8" Fh Woodscrew
- (2) 1/4" x 3 1/2" Carriage Bolts
- (4) 1/4" Flat Washers
- (3) 1/4" Wing Nuts
- (1) 1/4" x 2 1/2" Carriage Bolt

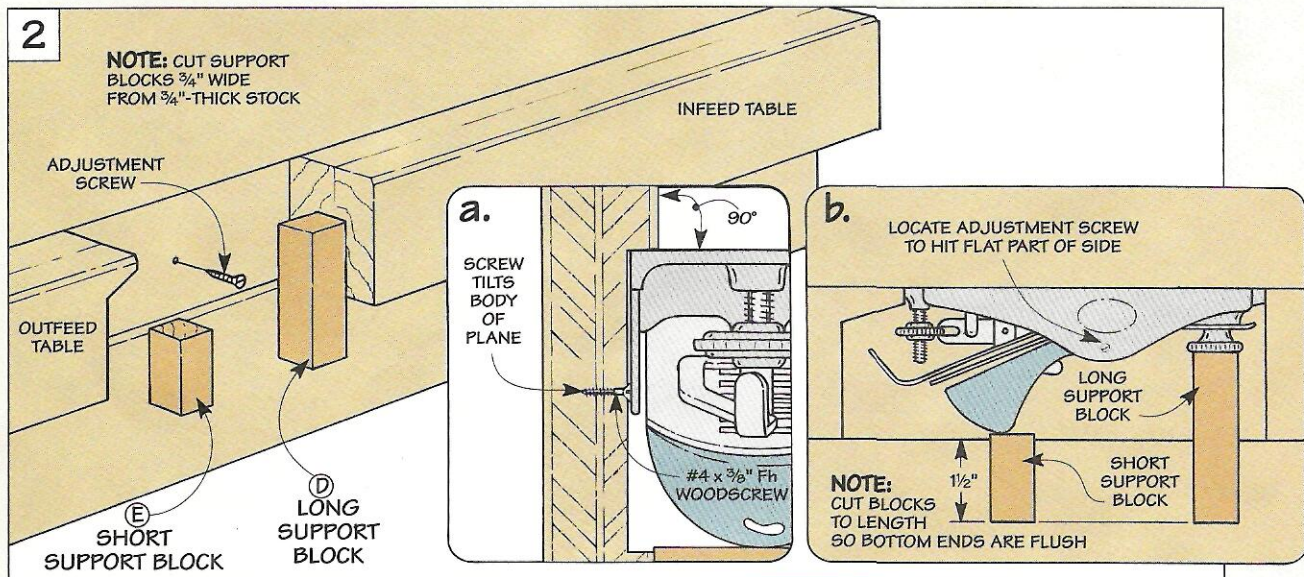



# Pressure Bar & Guard

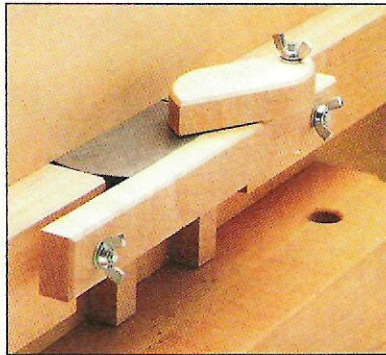

At this point, the jointer has a "pocket" for the plane to rest in. But there's nothing to prevent it from rocking to the side as you make a cut. That's where the pressure bar comes in.

**PRESSURE BAR.** Like its name implies, the *pressure bar (F)* is a strip of  $\frac{3}{4}$ "-thick hardwood that presses against the *side* of the plane, see photo above and Fig. 3. Pressure is applied to the bar by tightening wing nuts on a pair of carriage bolts.

The bolts pass through holes drilled through the pressure bar, tables, and fence, see Figs. 3 and 3b. An easy way to ensure these holes align is to carpet tape the pressure bar flush with the top of each table, see Fig. 3a. Then lay out and drill the holes.

Before installing the pressure bar, there are two things left to do. To accept a carriage bolt that holds a guard in place, drill a sin-

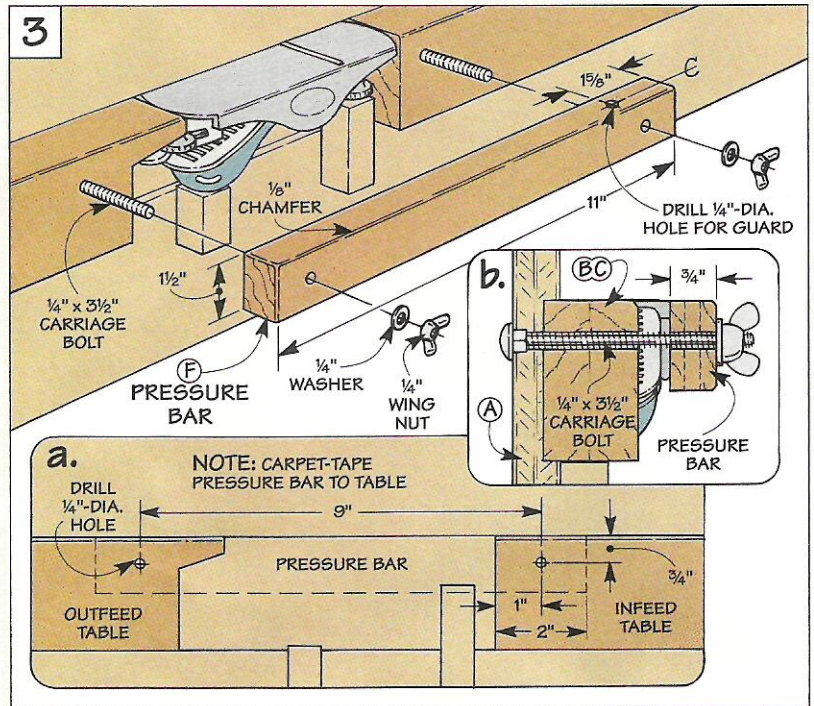

gle hole through the width of the bar, see Fig. 3. And, as before, chamfer the outside edges of the pressure bar.

## GUARD

Now you're ready to add the guard. It covers the exposed part of the blade so you don't cut your hand if you accidentally slip off the workpiece, see photo.

The guard is a piece of  $\frac{3}{4}$ "-thick stock with a gentle curve at each end, see Fig. 4 and the Full-Size Pattern below. One curve keeps

the workpiece from catching as you feed it across the plane. And the other removes the sharp corner. Here again, there's an  $\frac{1}{8}$ " chamfer around the top edge.

**ATTACH GUARD.** The guard is held in place with a carriage bolt that passes through the hole you drilled earlier in the pressure bar and a hole in the guard, see Fig. 4. To keep the guard off the plane blade, a washer is used to raise it above the pressure bar. Finally, thread on a washer and wing nut to tighten the guard in place.

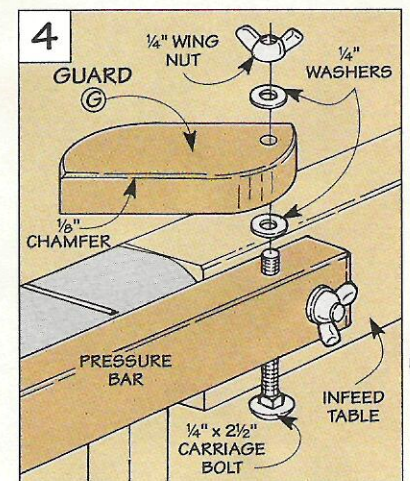
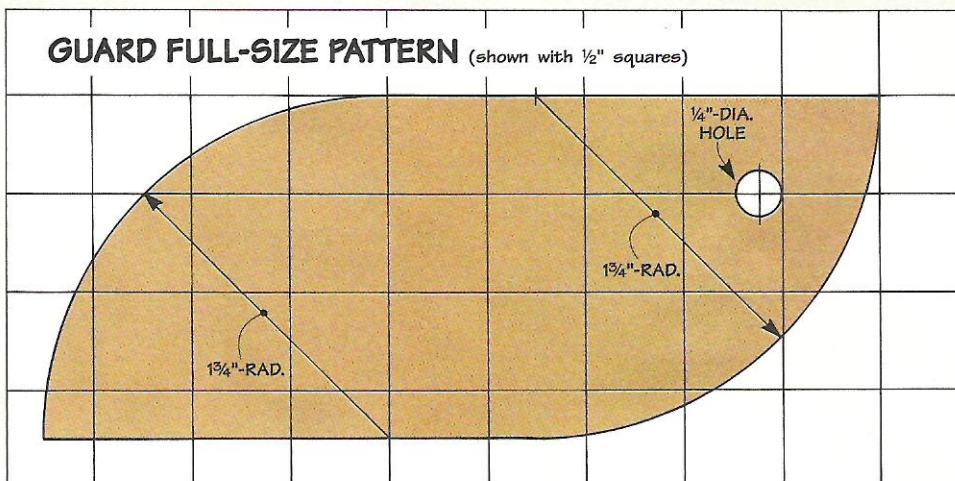



# Setup

The few minutes it takes to set up the jointer can make a big difference in the quality of cut you get.

**SMOOTH CUT.** To produce a smooth cut, the jointer needs to be secured tightly in a vise, see Step 1. Also, to keep the blade from digging into the workpiece, adjust the depth of cut to remove just a thin shaving, see Step 2.

**SQUARE EDGE.** In addition to a smooth cut, you're also looking for a square edge. So you may need to tighten (or loosen) the adjusting screw until the sole is square to the fence, see Steps 3 and 4.

Finally, after tightening down the pressure bar and guard (Step 5), simply make as many passes as necessary to get a straight, square edge, see Step 6.

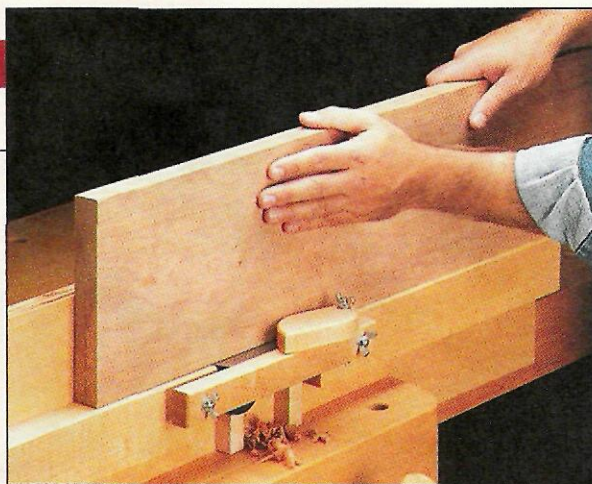

▲ Whether you're working with a wide board or a small workpiece (see page 4), the key to getting a smooth, square edge is adjusting the jointer correctly and then making a series of light passes.

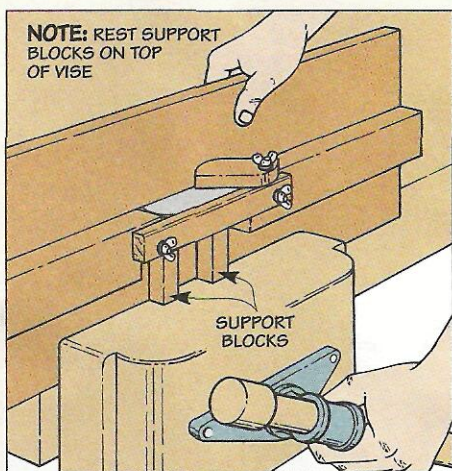

**Step 1.** To provide as much support as possible when making a cut, tighten the jointer in a vise. For added stability, the support blocks rest on top of the vise.

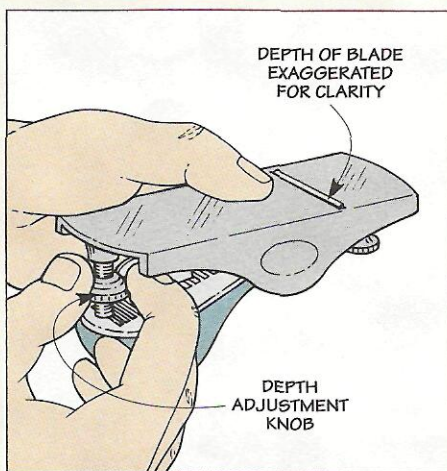

**Step 2.** Now adjust the blade so it extends just a hair beyond the sole of the plane. To check the setting, a test cut should remove thin, wispy shavings.

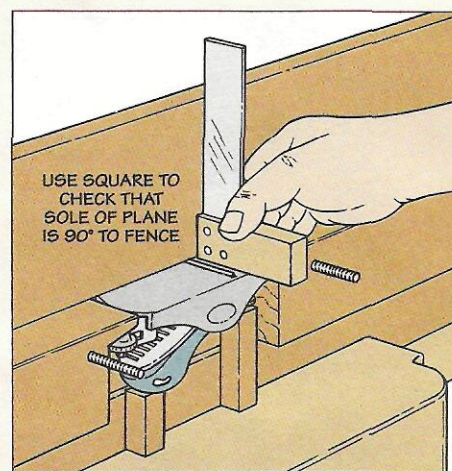

**Step 3.** After removing the pressure bar and guard, set the plane in its "pocket" and use a try square to check that the sole is 90° to the fence.

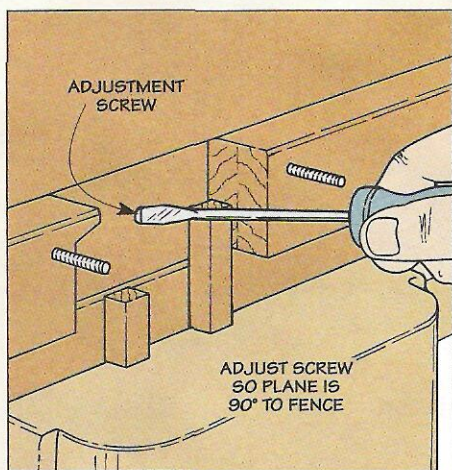

**Step 4.** If you need to square up the plane, tighten (or loosen) the adjusting screw. Now check the plane again and readjust the screw if necessary.

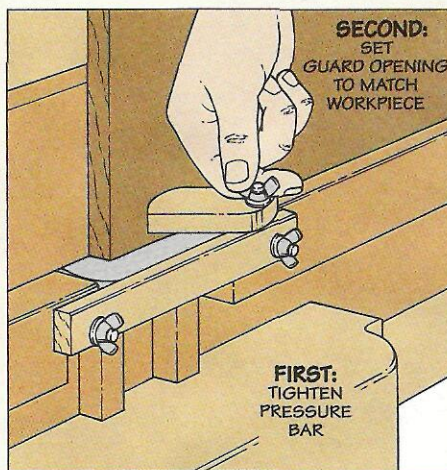

**Step 5.** With the pressure bar tightened down against the plane, use the workpiece to set the opening for the guard. Then lock the guard in place.

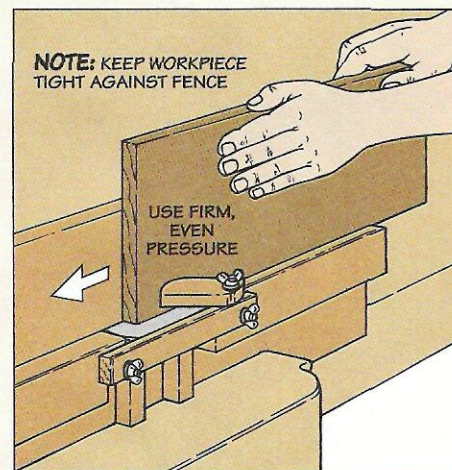

**Step 6.** Finally, keeping the face of the workpiece tight against the fence, use firm, even pressure as you push it across the jointer.



# Circular Saws

## Our Testing Team (from left to right)

**Steve:** Whether he's in his shop cutting up plywood, dimension lumber, or hardwood boards, Steve often relies on a circular saw.

**Cary:** A circular saw is the tool of choice when Cary needs to break down large sheets of plywood to manageable size.

**Ken:** A professional carpenter and cabinetmaker, Ken uses a circular saw extensively to cut a wide variety of materials.

**Doug:** When he's not remodeling his house, Doug gives his circular saw a workout by helping friends with projects of their own.

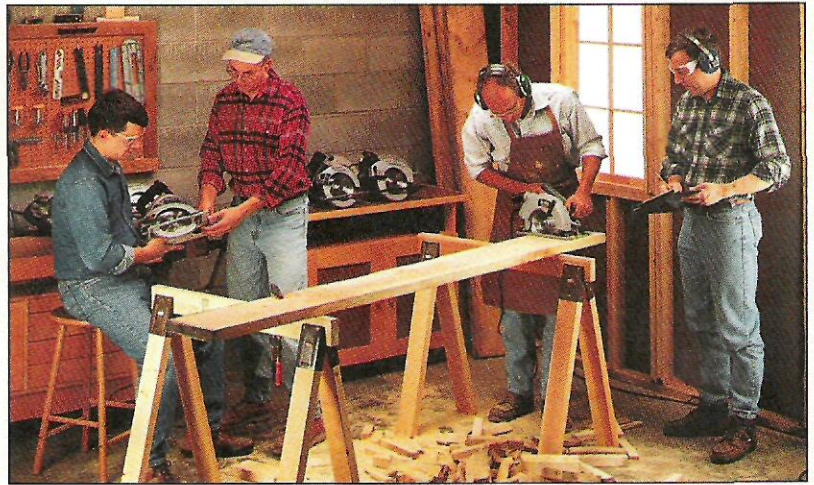

A pile of sawdust and cutoffs. That's all that was left of the truckload of plywood and 2x10's that we cut up to test the circular saws shown below. But when the dust finally settled, what we had to show for it was definitely worth the effort — the best (and worst) circular saws for the money.

**TEAM.** To get a wide variety of viewpoints when testing the saws, we deliberately rounded up a team of people with different woodworking interests and experience, see photo and list above. Of course, one of the problems with this is you're likely to end up with more than one "best" saw.

But that's not necessarily bad. Each person picked the saw that was best for him based on the type of work he does most frequently. Which is just the kind of information I'd want when buying a saw.

**PROCEDURE.** Unlike the final selections, the testing procedures for each saw were identical. We started out by buying all the saws we could find (eleven in all) that fell in a medium-price range (\$39-\$80), see margin at left.

Of these saws, the Ryobi, and the top end Sears and Skil saws

were the only ones to come with carbide-tipped blades — something to consider when comparing the prices of the saws. So to keep things on an equal footing,

we put a new carbide-tipped blade on each saw.

With saws in hand, the testing began. To provide a reliable comparison, each team member made

## Prices

### Black & Decker

300 \$59.00  
200 \$49.99  
100 \$39.00

### Quantum

3100 \$67.00

### Ryobi

W660 \$79.95

### Sears

10825 \$79.99  
10224 \$59.99  
10223 \$49.99

### Skil

5350 \$66.99  
5250 \$53.03  
5150 \$44.71



**Spindle Lock.** A large, flat spindle lock button located near the pointed button located on top of the Quantum (left) is more



convenient to use than the pointed button located on top of the Sears saw (right).

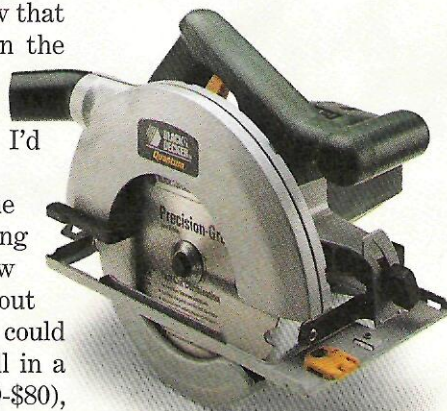

**Quantum**



**Skil**



## SELECTING TOOLS

the exact type of cut over and over using a different saw each time.

Some of the cuts (ripping eight-foot 2x10's for example) tested the power and performance of the saw. While others (like crosscutting plywood and making plunge cuts) gave us a good feel for the overall balance of the saw.

At the end of the day, we all got together to compare notes. And I quizzed them about what they liked (and just as important) what they didn't like about each saw.

**Q:** *First things first. How easy was it to change blades?*

**Ken:** Since I cut a lot of different materials, I'm always changing blades. So that makes the spindle lock on the Quantum, and top end Sears, Ryobi, and Black & Decker (B&D) saws a real plus.

**Steve:** Even on the saws we tested that *had* spindle locks, the ones on the Quantum and B&D

were handier to use than those on the Sears and Ryobi. (See center photos on opposite page.)

**Cary:** I usually stick with the same blade when breaking down plywood. So I can take or leave a spindle lock.

**Steve:** When it comes to changing blades, another thing I like is the "try square" wrenches that come with the top end B&D and Quantum saws. (See photos above.) The long handles give me plenty of leverage. And they don't dig into my hands like the short wrenches on the other saws.

**Q:** *What about the operation of the blade guards on the saws?*

**Doug:** That's where I noticed a big difference. Especially since I make a lot of plunge cuts and have to manually retract the guard.

To make a controlled cut, I want a saw that's compact enough so you can draw the lever on the blade

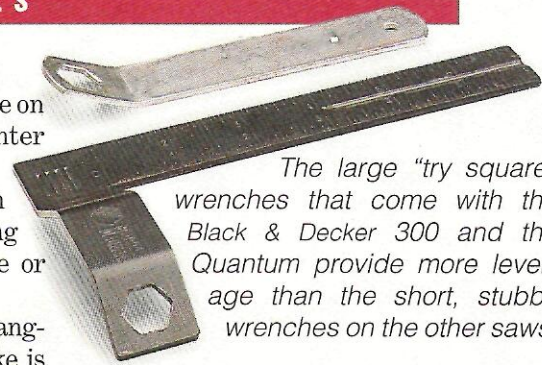

The large "try square" wrenches that come with the Black & Decker 300 and the Quantum provide more leverage than the short, stubby wrenches on the other saws.

guard all the way forward and grasp the front handle at the same time — like the Skil saws. (See photos below.)

The short lever on the Ryobi required such a long stretch, I almost had to let go of the handle. And the Sears saws were just too bulky to hold comfortably.

**Ken:** One curious thing was the top end Skil saw tried to eliminate this stretch altogether by adding a remote "lift." But I couldn't even use this lever without letting go of the front handle of the saw — and this seemed dangerous to me.



**Blade Guards.** The compact design of the Skil (left) lets you retract the blade guard and grasp

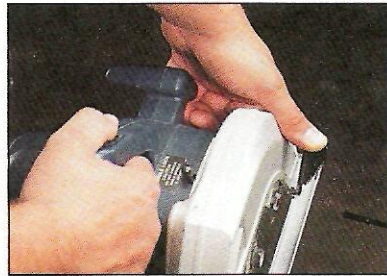

the front handle at the same time. This provides a more stable grip than the long reach on the Ryobi



(center). Unfortunately, to use the remote "lift" on the Skil 5350 (right), you have to let go of the handle.



**Sears**



**Ryobi**



**Black & Decker**



## Adjustments & Controls

**Q:** *The adjustments and controls are also something to consider when buying a saw. For example, what about something as simple as turning on the saw?*

**Doug:** It can't get any easier than with the Quantum and B&D saws. Since they don't have a "safety lock," all I have to do is pull the trigger and I'm in business.

**Cary:** But a saw without a safety lock gives me the jitters. If you have kids around like I do (or grab the saw without thinking), it's an accident waiting to happen.

That's why I liked the safety lock on the Skil saws. It's on the side of the handle. (See photos at

right.) So even though I can't accidentally turn the saw on, all I have to do is push the lock with my thumb and squeeze the handle.

**Ken:** It's not that easy with the Sears and Ryobi saws. Since the lock is on top of the handle, I had to stretch my thumb way up over the handle.

**Q:** *How about the adjustments to make a bevel cut or set the depth of cut?*

**Steve:** I make a lot of bevel cuts. But one saw just about makes that impossible — the lowest priced

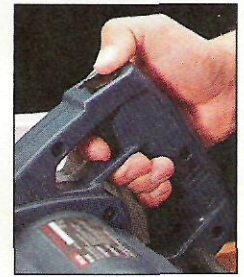
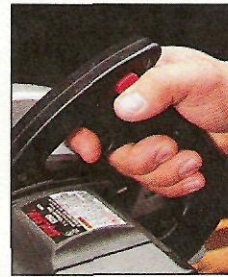

**Safety Lock.** The Skil has a safety lock on the side of the handle (left) that's handier to use than the top-mounted Sears lock (right).

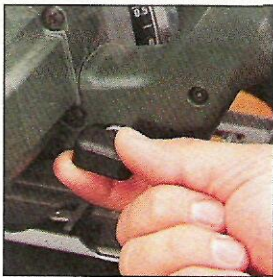

**Depth Adjustment.** The plastic knob on the Quantum (left) provides a more comfortable grip than the wing nut on the B&D (center). But neither are knuckle-busters like the depth adjustment lever on the Skil (right).

Skil. No matter how much pressure I applied to the wing nut that locks in the adjustment, the base still slipped when making a cut.

But the plastic knobs on the Quantum, Ryobi, and the top end B&D saws locked down tight. (See photos at left). And they're more comfortable to grab onto than the cast metal wing nuts on the lower priced B&D saws.

**Ken:** Anything is better than the lever that adjusts the depth of cut on the Skil saws. It's tucked between the blade guard and the back handle. Not only is it hard to get at, but the lever also sticks — it's a real knuckle-buster.

## Performance

**Q:** *One of the keys to making a controlled cut is the weight and balance of a saw. How would you rate the overall "feel" of the saw?*

**Cary:** Using the Skil saws was as comfortable as slipping my hand into a well-worn baseball glove. They're compact, lightweight, and have good balance.

**Steve:** I liked the balance of the Skil saws too. But I'd say that the Quantum and two upper end B&D saws nudged them out. Sure, they're a bit heavier. But with their large bases and comfortable handles, these saws have a nice solid feel.

**Ken:** One thing I noticed was I didn't get as tired using the Skil,

B&D, and Quantum saws. Probably because when I grab the back handle, my hand is at a fairly low angle. (See photos below.) So it's easy to push the saw straight through the cut.



**Hand Position.** Since your arm is held at a lower angle when using the Skil saw (left), it's not as

But when I grab the handles of the Sears and Ryobi saws, my hand is at a steeper angle. So it feels like I'm hunched up when making a cut — almost like I'm working against the saw.



tiring to use as the Ryobi saw (right) that requires you to hold your arm at a steeper angle.



**Q:** Just as important as weight and balance is the quality of cut. Does the saw run smooth? And does it have enough power so the saw won't bog down?

**Cary:** Even when I was ripping "two-by" stock, the two top end Skil saws ran like a well-tuned car with plenty of power.

What surprised me is that the lower priced Skil saw didn't follow suit. This saw seemed badly underpowered. And it rattled like ice in a blender.

**Steve:** Talk about a rattle problem. I could feel the vibration of the Sears and Ryobi saws through the handles, the board I was cutting, and the sawhorse. Probably a good sign there's some unnecessary wear going on in the gears and bearings.

**Doug:** But even with the vibration, I felt that the Sears and Ryobi saws ran strong. In fact, if all I wanted was brute power, I'd go with the Ryobi in a heartbeat.

But I'm looking for a saw that has plenty of power to do the job, yet runs smooth enough so it won't wear me out after several hours of cutting. I thought the Quantum and the two top end B&D saws were just the ticket.

**Q:** There's one other thing that figures into the performance of a saw — accuracy. How accurately could you cut to a layout line?

**Steve:** Most of the saws have some type of fixed notch to help you track the blade along the lay-

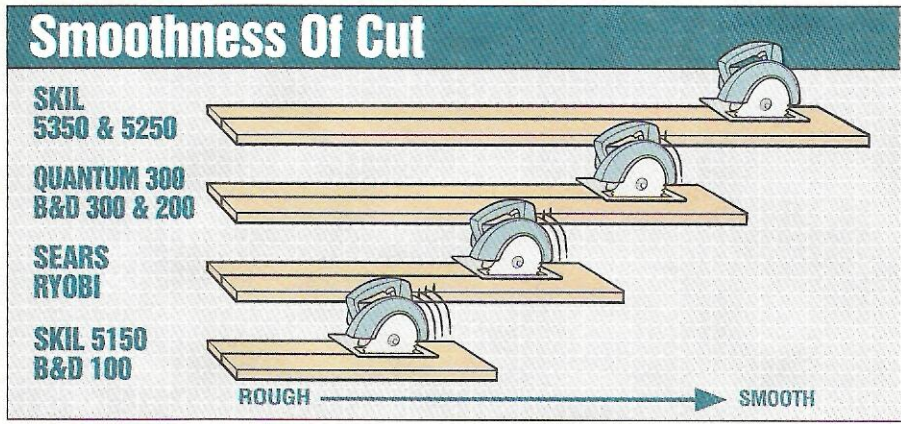

out line. (See photos below.) Since I change blades quite often (and they vary in thickness), this means I have to position a different part of the notch on the layout line depending on the blade I'm using.

That's why I liked the adjustable indicators on the Quantum and the top end B&D saws. To

So I chose the Quantum. It's a strong running saw. And when you add on the spindle lock and the fact that it has a dust collection hook-up for a shop vacuum, it's a lot of saw for the money.

**Steve:** Except for the fact it doesn't have a safety lock, I like the Quantum. It will take care of just about any job I can think of in the shop. And with its wide base and comfortable handles, I'm sold on its rock solid cut.

**Doug:** I can see myself getting a lot of remodeling done with the top of the line Black & Decker. It's similar to the Quantum in the way it looks, feels, and performs. But it costs less. All in all, a tough saw to beat.

**Cary:** There's no question about the saw I'd choose — the top end Skil saw. It's compact and lightweight. Just right for those long reaches when I'm crosscutting a full sheet of plywood. And it's the smoothest running saw of the lot.

*There's more to consider than just the price tag when selecting a circular saw.*

compensate for different blade thicknesses, I just loosen the screw and adjust the indicator.

**CONCLUSIONS**

**Q:** Okay, lets sort things out. Based on the type of work you do, which saw would you buy?

**Ken:** If I could just slap on a better height adjustment, the middle of the line Skil would be an easy pick. But changing the depth of cut would drive me nuts.



**Indicator.** Unlike the fixed notch on the Skil saw (left) that marks the path of the blade, the indica-

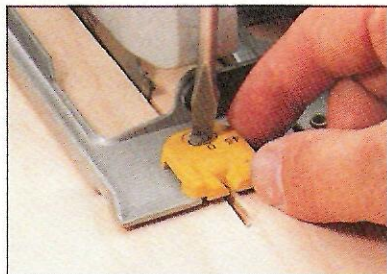

tor on the Quantum (right) can be adjusted if you use blades that vary in thickness.

FINAL PICKS			
TESTER	FIRST CHOICE	SECOND CHOICE	LAST CHOICE
Ken	Quantum	Skil 5250	B&D 100
Steve	Quantum	B&D 300	Skil 5150
Doug	B&D 300	Quantum	Skil 5150
Cary	Skil 5350	Ryobi	B&D 100



# Built-Up Moldings

*All it takes to create detailed molding is a router, a handful of bits, and our simple technique.*

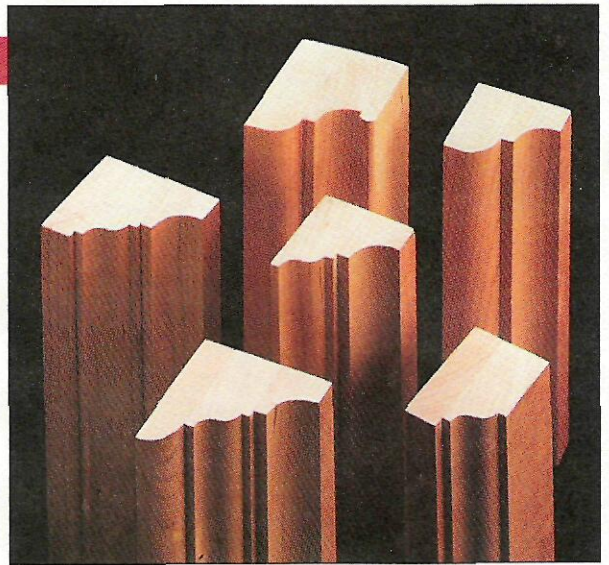

One of the things that usually catches my eye on a fine piece of furniture is the detail on the molding. But since moldings like this are usually made on industrial shapers and molders, they're expensive and often hard to find.

So I use a simple technique to make these moldings myself. All it takes is a router (or router table) and a handful of ordinary bits.

**ADVANTAGES.** In addition to being a lot less expensive than manufactured moldings, building your own moldings has another advantage.

You can make them from the same wood you're using for the project you're building. This way, the molding will match the rest of the project perfectly when you apply the finish.

## STRIPS & LAYERS

There are two basic ways that you can create these moldings. The technique is similar for both. It's just a matter of "building" them up one piece at a time.

**STRIP MOLDING.** Strip molding is what I normally apply to the top of casework (such as a large cabinet or grandfather clock), see Fig. 1. I make these by gluing up strips of wood that have a profile routed on one edge. Then the molding is mitered and attached to the cabinet.

To make strip molding, all you have to do is rout the front edge of a board and then rip the strip to width, see box below. (For more on routing profiles, see the article on page 22.)

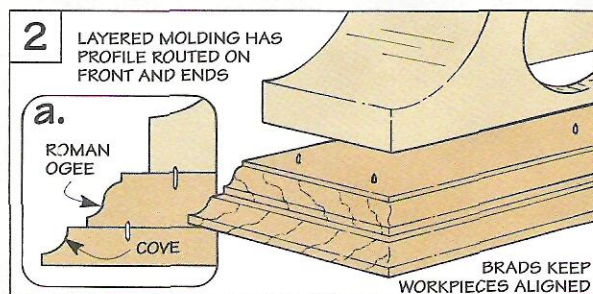
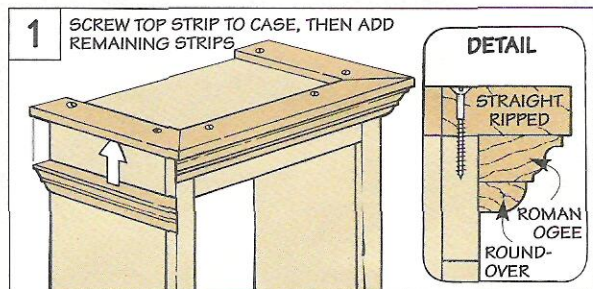

## Step-by-Step

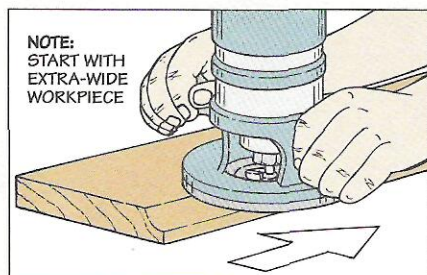

**First: Rout Profile.** For safety, start with an extra-wide workpiece and rout the edge in a left-to-right direction.

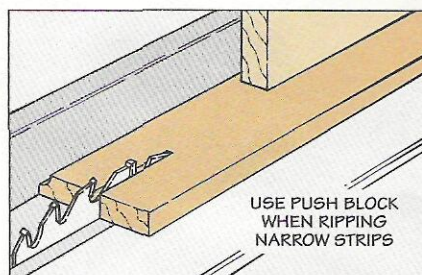

**Second: Rip Strip.** With the routed edge against the fence, use a push block to rip the strip to width.

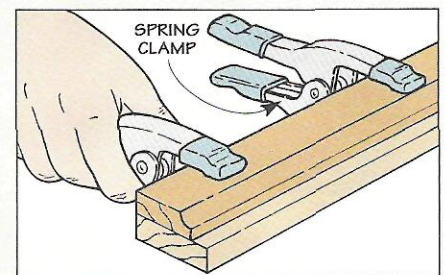

**Third: Glue Up Strips.** Now the strips can be glued and clamped together with the back edges flush.



# Building Blocks

**LAYERED MOLDING.** Layered molding is basically a glued-up stack of full-width boards with the profile routed across the front and ends of each board, see Fig. 2.

Layered molding is faster to make and easier to install than strip molding because you don't have to deal with mitered corners. All you have to do is cut each layer to finished size and then rout the profile.

Note: When gluing up layered molding, the pieces can become quite slippery and slide around. To keep the strips aligned during glue up, refer to the margin tip below right.

The only disadvantage I've found to layered molding is the exposed end grain. But by sanding the ends several grits finer than the rest of the project, it's less noticeable.

Design Note: As a general rule of thumb, I limit the width of layered moldings to workpieces around 5" or less. Anything wider has a tendency to warp with the changes in humidity.

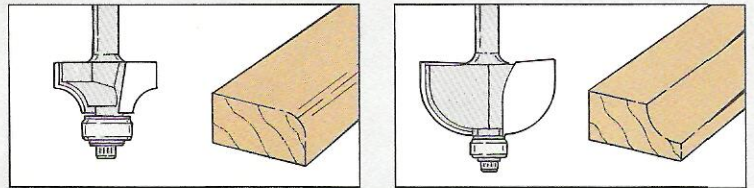

**Round-Over.** Round-overs come in many sizes. They look best on the top of a molding.

**Cove.** Covs also come in a variety of sizes. It's the profile I use most often on the bottom.

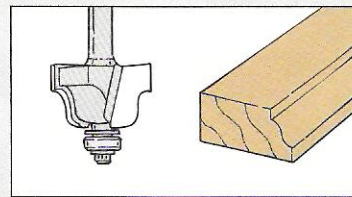

**Roman Ogee.** A Roman ogee looks good in the middle or at the bottom of a molding.

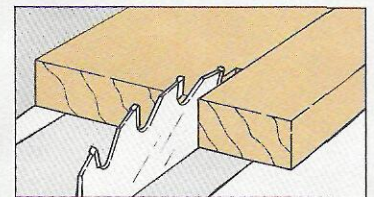

**Straight Cut.** One of the simplest ways to top off a profile is to add a straight-ripped edge.

## PROFILES

One of the things I like best about built-up moldings is you don't need a whole cabinet full of router bits. For the six profiles shown below, I only had to use four common router bits: a cove bit, a Roman ogee bit, and two round-over bits, see box in upper right-hand corner.

As you're making profiles, try experimenting by rearranging them in a different order to change the overall appearance of the molding. Or change the thickness of the pieces that make up the molding. You can vary the number of strips or layers, or even the bits you use to rout the profiles. The possibilities are endless.

## Double Profiles

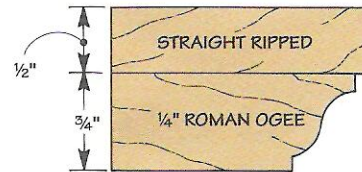
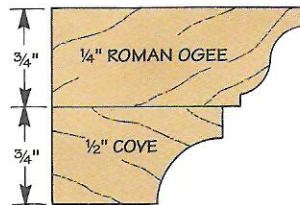
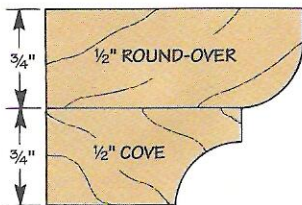

To keep layers aligned during glue up, nail a few wire brads in one of the layers. Then snip off the heads of the brads.

## Triple Profiles

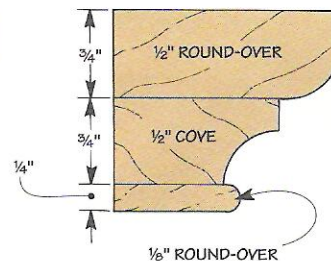
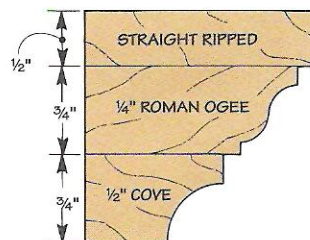
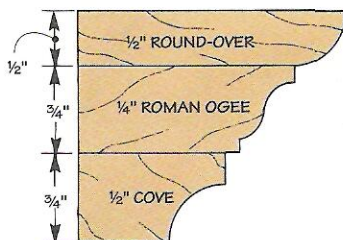





# Built-Up Molding Wall Mirror

*This handsome mirror gives you a chance to experiment with built-up moldings.*

As we were working on the built-up molding article on page 12, we experimented with a number of different profiles. I wasn't the only one that noticed the leftover strips laying around the shop.

Kurt Schultz (our Senior Illustrator) picked up the strips and started stacking them as if they were a set of Legos — creating different profiles.

After playing with them a few minutes, Kurt told me he had just

the project in mind for the strips. So I wasn't too surprised when he showed up the next day with this wall mirror, see photo at right.

**THREE BITS.** What intrigued me most about the wall mirror was it only required three router bits to make all the profiles: a 1/2" round-over, a 1/4" Roman ogee, and a 3/8" cove bit. By simply rearranging the moldings, Kurt created strik-

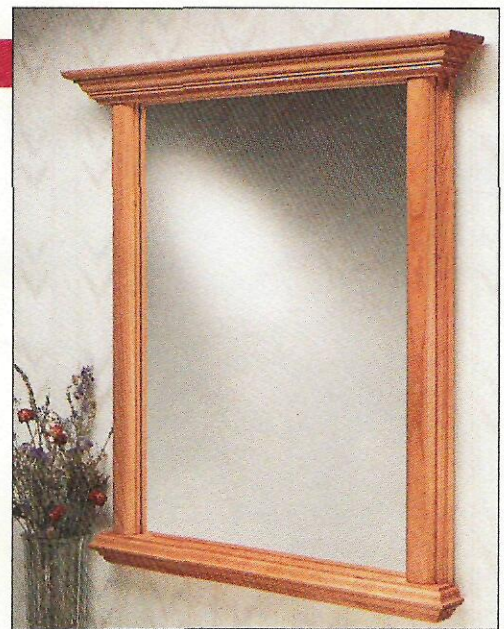

ingly different moldings for the top, bottom, and sides of the mirror, see Side View below.

The frame for the mirror consists of four parts — each a built-up molding, see Exploded View. There's a top and a bottom, and two identical sides. To build the mirror, I started with the sides.

## SIDES

Each side is built-up of two pieces of hardwood, see Fig. 1. (I used cherry.) The 3/4"-thick base piece has a 3/8" cove routed on the outside edge. And a 1/2" round-over is routed on both edges of the top 1/2"-thick piece. (For tips on routing smooth, consistent profiles, see the article on page 22.)

Once you're through routing the profile on each workpiece, glue and clamp the two pieces together. Here, the top piece is centered on the width of the wide, flat surface of the coved piece. (For a tip on keeping the pieces aligned during glue-up, see the margin tip on page 13.)

## TOP & BOTTOM

With the sides complete, the next step is to make the top and the bottom moldings. These pieces are made much like the sides, but with three important differences. First, there are three layers instead of two. Second, the ends of each piece are routed. And third,

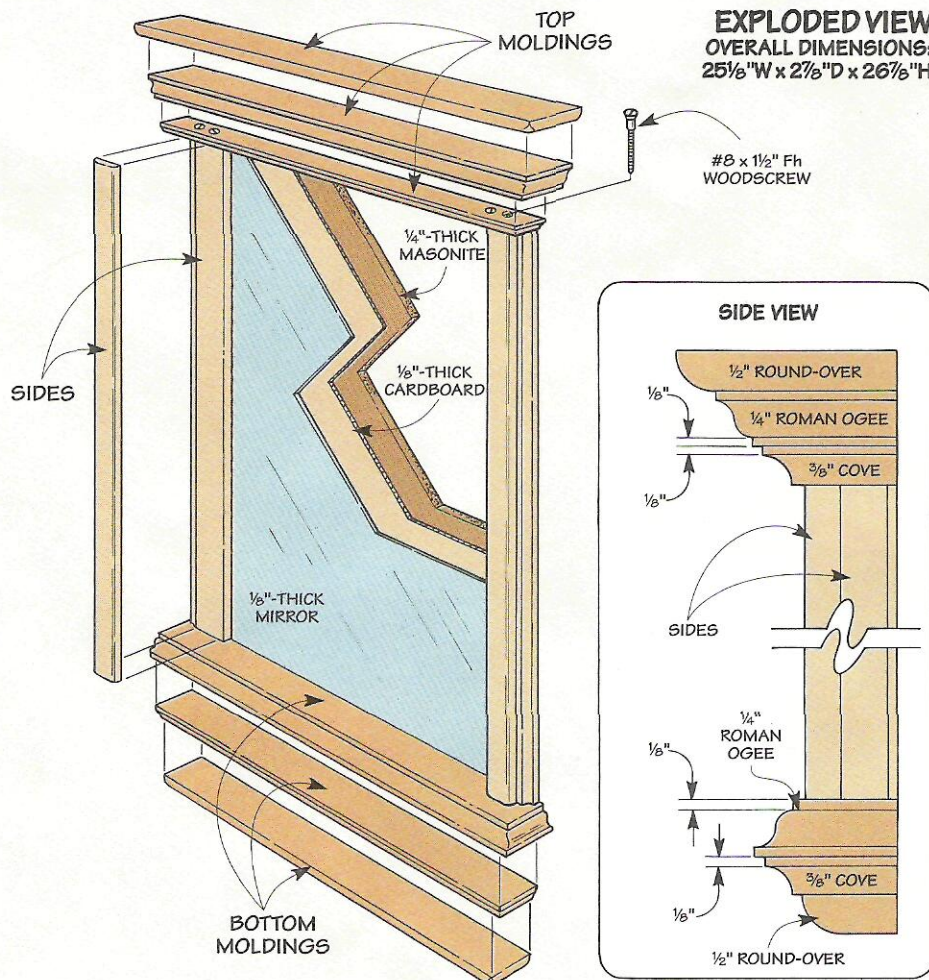



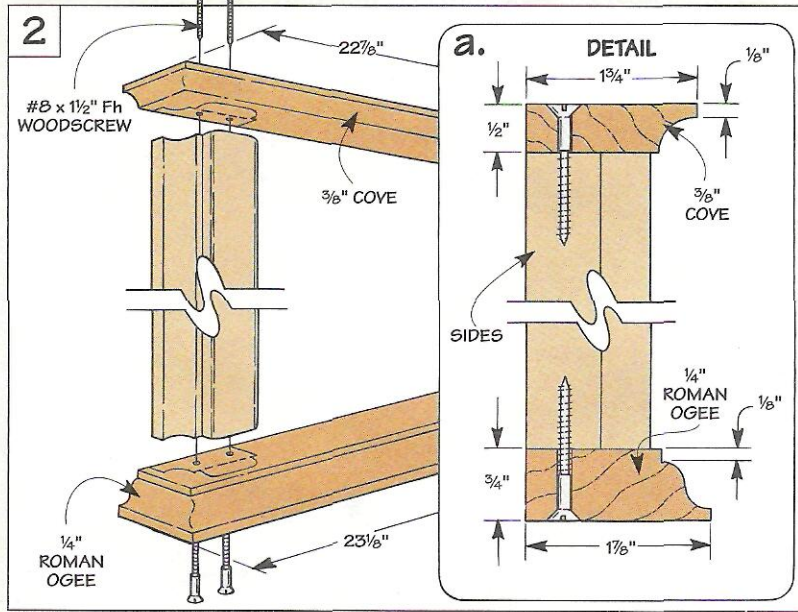
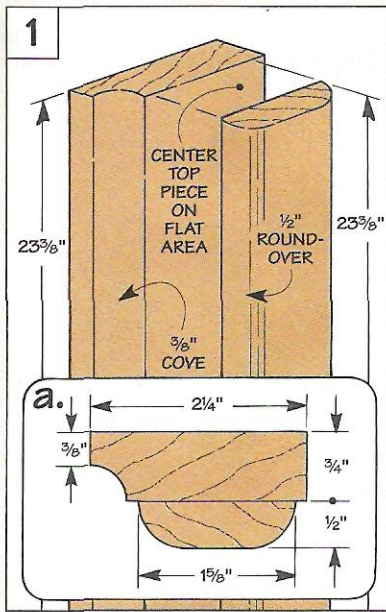

the top and bottom moldings are arranged in a different order.

**JOINERY.** To keep the joinery simple, but still provide a strong frame, I screwed the built-up moldings to the sides. But since I didn't want the screws to show, I came up with a simple trick to conceal them.

Start by gluing and screwing one layer of each molding to the sides of the mirror, see Fig. 2. Then hide the screws by gluing on the remaining layers, see Fig. 3.

Note: To make aligning the layers easy, glue on one piece at a time — allowing the glue to dry between each layer.

**MIRROR**

With the frame complete, you're just about ready to add the mirror and the mounting hardware. But there are a couple more things to do.

**RABBET.** First, the mirror fits in a 1/2"-deep rabbet that runs along the back inside edge of the frame, see Fig. 4. To make the rabbet, I used a 3/8" rabbet bit mounted in a hand-held router.

**FINISH.** Second, after you've squared up the corners of the rabbet with a chisel, sand the entire project up to 220 grit. Then apply

the finish. For this mirror, I wiped on three coats of Danish oil, sanding between coats with 220-grit sandpaper.

Once the finish was dry, I had my local glass shop cut a 1/8"-thick mirror to fit the rabbet. Then, to protect the back of the mirror, I covered it with a piece of 1/4"-

thick cardboard and a piece of 1/4"-thick Masonite, see Fig. 5.

To complete the project, install turnbuckles to hold the mirror in place, see Fig. 5. Then screw on a pair of hangers to mount the mirror on the wall. (Turnbuckles and hangers are available at most hardware stores.)

*A cove, a round-over, and a Roman ogee bit are all you'll need to make the moldings for this project.*

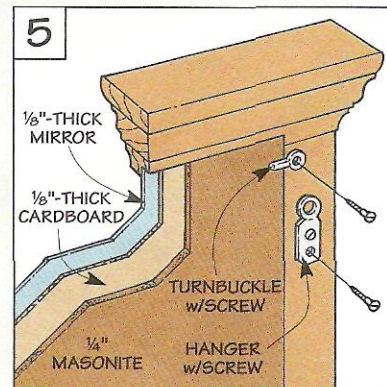
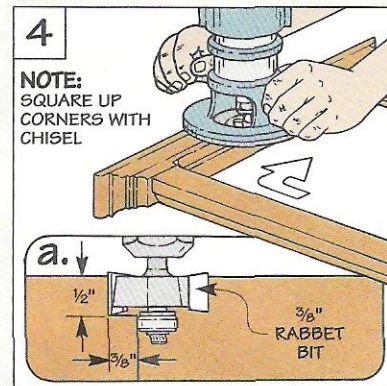
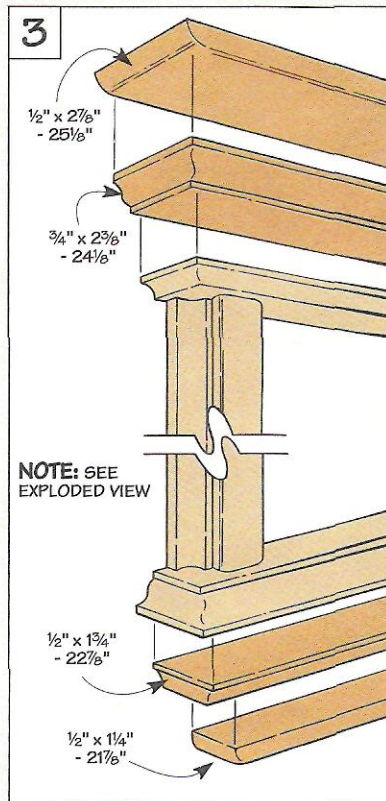



# Cutting Guide

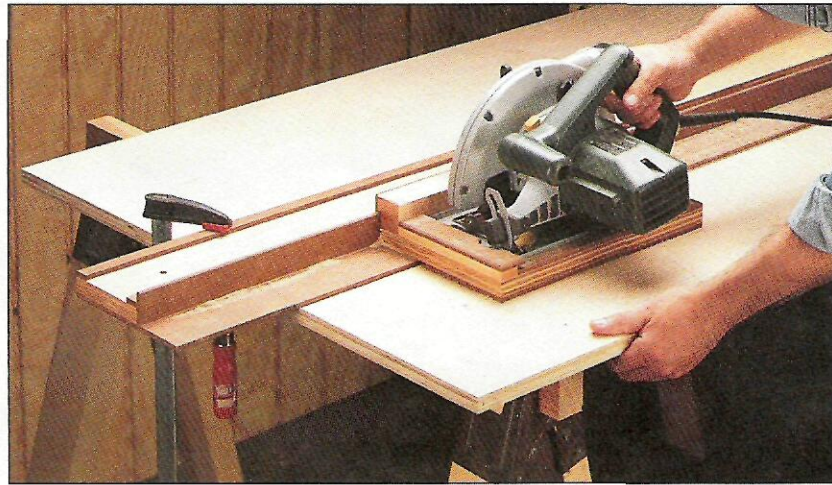

**S**ometimes a power tool seems to have a mind of its own. Take a circular saw or hand-held router for instance. Even when you clamp a straightedge to the workpiece, they often wander off course in the middle of a cut.

To produce a cut with dead-on accuracy, I built a cutting guide for my circular saw and router, see photo above and on opposite page.

**CARRIAGE.** The unique thing about this cutting guide is the circular saw (or router) mounts to a carriage that *hooks* onto the cutting guide. Because the carriage is “captured” by the cutting guide, it’s impossible to stray off the line as you slide the tool along to

*A unique tracking system on this cutting guide ensures straight, accurate cuts.*

make a cut. (Note: You’ll need to build a separate carriage for each tool.)

**NINE-FOOTER.** Since I wanted to be able to cut the full length of a sheet of plywood, the cutting guide is over 8-feet long. In fact, to support the carriage at the start and finish of a cut, it’s a full 9-feet long.

**TWO SECTIONS.** But storing something that long can be a hassle. So I built it in two sections — a five-foot and a four-foot section, see Exploded View. With the long section clamped in place, you can cut across the width of a full sheet of plywood. Or simply connect the two parts to cut down the length of the sheet.

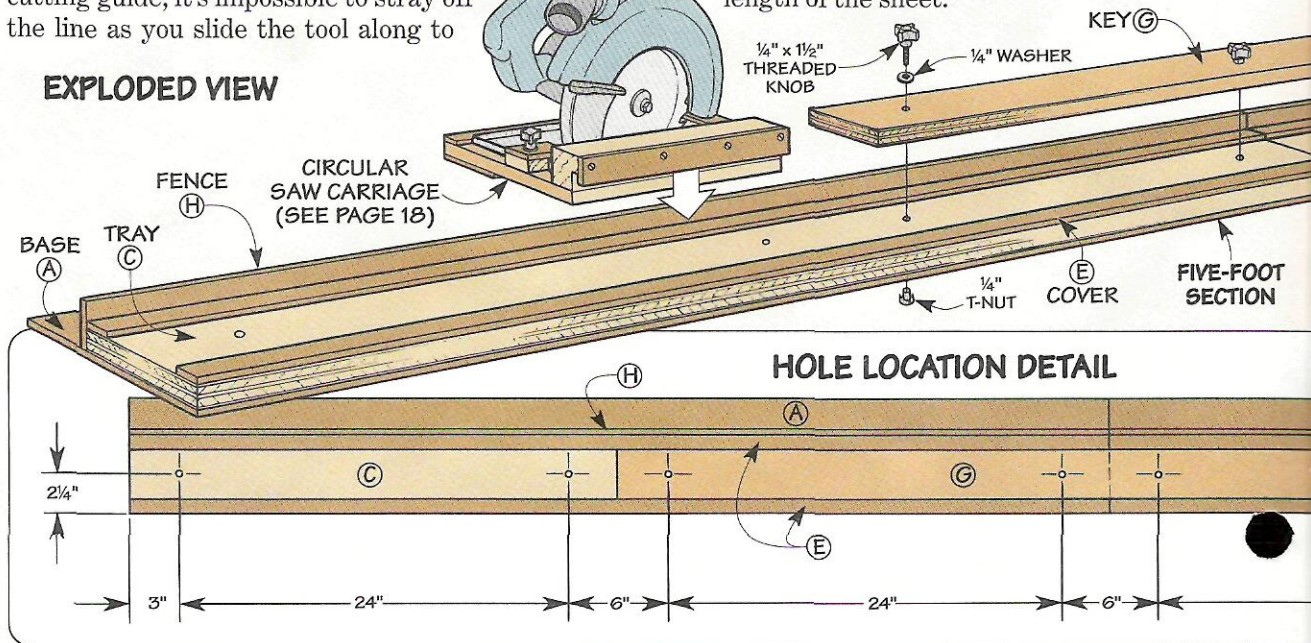



# Cutting Guide

Although the two sections of the cutting guide are different in length, they're built exactly alike. Each section consists of four parts: a base, tray, cover, and fence, see Exploded View. And there's a single "key" that joins the two sections together.

**BASE.** To provide a platform for the carriage to ride on, I began by making the *base* (A) and *base extension* (B), see Fig. 1. These are strips of 1/4"-thick Masonite that are cut to finished length and a rough width of 8", see Figs. 1 and 2. Later, when you make your first cut with a circular saw, the base pieces will be trimmed to final width.

**TRAY.** The next step is to add a plywood *tray* (C) and *tray extension* (D) to help stiffen the base, see Fig. 1. To accept the key (added later), there's a wide, shallow groove that runs the length of the tray pieces.

Forming this groove is a simple two-step process. First, use contact cement to glue on a Masonite *cover* (E) and *cover extension* (F) that are the same size as the tray pieces, see Fig. 2. Second, cut a 3"-wide groove centered on the

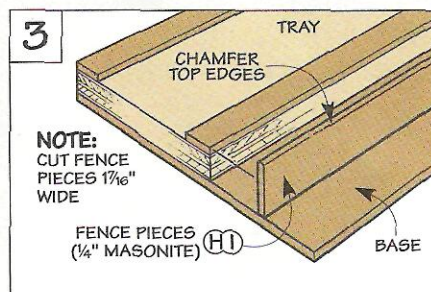
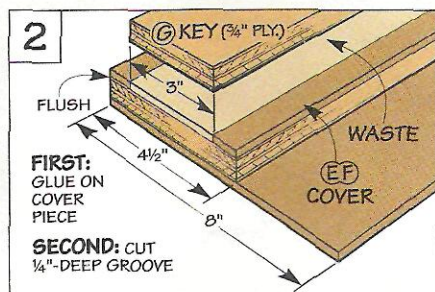
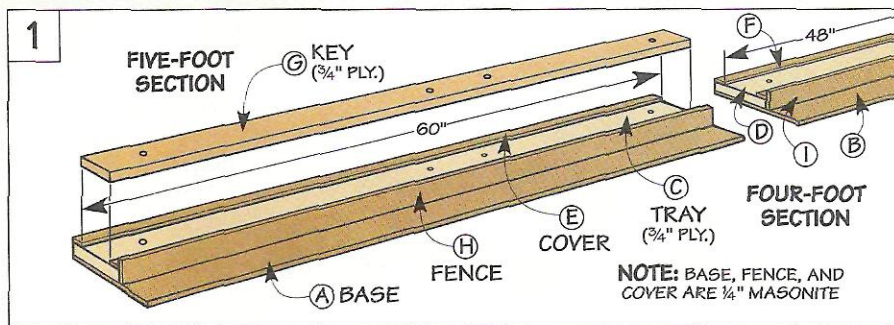

width of the cover pieces.

**KEY.** After attaching the tray pieces to the base (here again, I used contact cement), the next step is to cut a plywood *key* (G) to fit the groove, see Fig. 2. The key spans the two sections of the cutting guide and locks it together.

To make this work, the key is held in place with threaded knobs that tighten into T-nuts installed in the bottom of the cutting guide, see details in the Exploded View.

(For a complete hardware kit, see page 18.) The holes are located so you can also store the key on the long section of the cutting guide.

**FENCE.** Now all that's left is to add the *fence pieces* (H and I), see Fig. 3. To form a lip that tracks the carriage, these pieces are cut taller (wider) than the thickness of the tray, then glued and clamped in place. (We used yellow glue.) Note: To keep the carriage from binding, be sure to wipe off the excess glue before it dries.

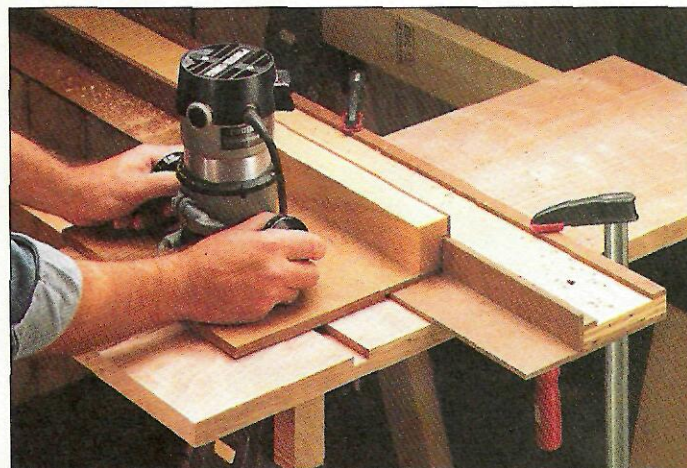
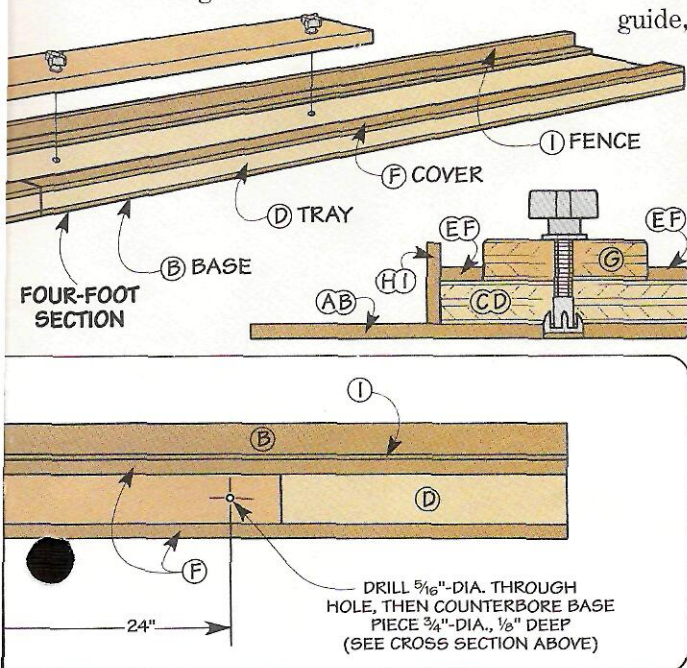

**Router.** With the cutting guide clamped across a wide panel, it can also be used to turn your hand-held router into a precision tool when routing dados (or grooves).



# Saw Carriage

I built two carriages for the cutting guide — one for a circular saw, and the other for a router. Whether you build one or both, a special hanger on each carriage hooks over the fence on the cutting guide to track the tool in a straight line, see photo at left.

**BASE.** The saw carriage starts out as a  $\frac{3}{4}$ " plywood base (J) for the saw to rest on, see Drawing and Fig. 1. To allow for a system of brackets that hold the saw in place, the base is cut 2" longer and wider than the metal base of your saw.

**OPENING.** The next step is to make an opening for the saw blade and guard. To locate this opening, first position the saw  $\frac{3}{4}$ " in from one edge of the base (for a side cleat added later), see Fig. 1. Then mark the opening and cut out the waste with a sabre saw.

**HANGER.** Now you're ready to add the hanger. To track the carriage in a straight line, the hanger has a groove that slips over the fence, see Hanger Detail.

This groove is built up from two parts: a hardwood rail (K) and a Masonite keeper strip (L). After rabbeting the rail, the keeper strip is glued and screwed in place to form the groove that locks the carriage on the fence.

**FOOT.** Once the hanger is attached with glue and screws, the next step is to add a Masonite foot (M), see Fig. 1. Since



To ensure straight, accurate cuts, a hanger on the carriage hooks over the fence on the cutting guide.

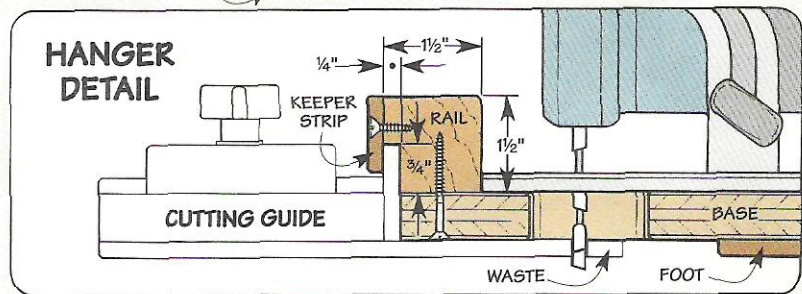
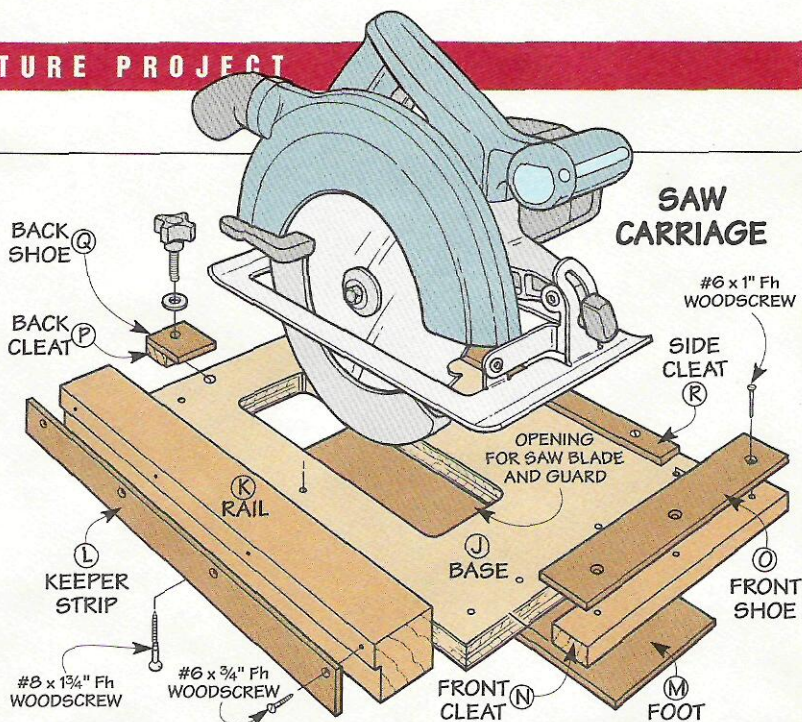

one edge of the carriage rides on the cutting guide, the foot supports the opposite edge and keeps it level when making a cut.

## BRACKETS

After gluing the foot in place, you can add the brackets that secure the saw base to the carriage.

**FRONT BRACKET.** The front of the saw is held in place with a two-part bracket. It's made up of a

hardwood front cleat (N), and a Masonite shoe (O) that form a lip for the metal base of the saw to slide under, see Fig. 2. To make this work, the cleat is cut to match the height of the front edge of the saw base, see Fig. 2a.

**BACK BRACKET.** After attaching the front bracket with glue and screws, I added a small back bracket. It's also built up from a back cleat (P) and shoe (Q), see

## Hardware

- (4)  $\frac{1}{4}$ " x  $\frac{1}{2}$ " Threaded Star Knobs
- (1)  $\frac{1}{4}$ " x 1" Threaded Star Knob
- (5)  $\frac{1}{4}$ " T-Nuts
- (5)  $\frac{1}{4}$ " Flat Washers
- (13) #6 x  $\frac{3}{4}$ " Fh Woodscrews
- (3) #6 x 1" Fh Woodscrews
- (3) #8 x  $\frac{1}{4}$ " Fh Woodscrews

To order a complete hardware kit for the cutting guide and both carriages, call ShopNotes Project Supplies at 1-800-444-7527.

Kit No. 519-6819-100.....\$8.95

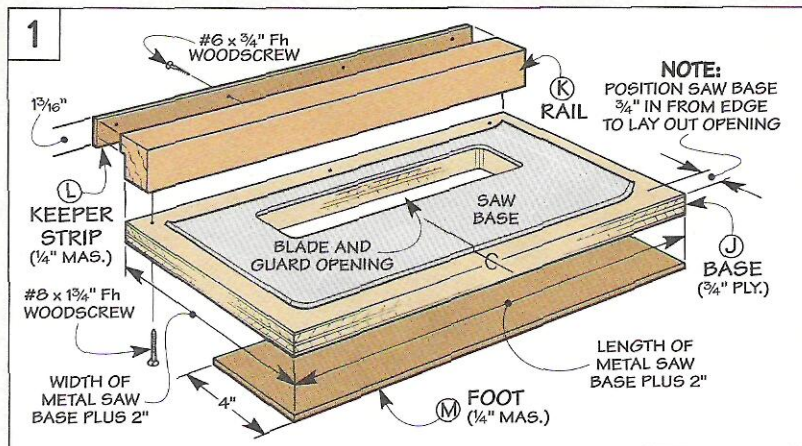



Figs. 2 and 2b. But to make it easy to remove the saw, this bracket is held in place with a threaded knob that tightens into a T-nut.

**SIDE CLEAT.** To make sure the saw stays put on the carriage, I added a *side cleat* (R). This is just a strip of Masonite that's glued and screwed to the base.

**REFERENCE EDGE.** All that's left is to clamp the cutting guide to a bench and trim the base to final width. The edge that's cut provides a reference to indicate the path of the saw blade. This way, it's just a matter of positioning this edge on the layout line to set up a cut.

Note: The reference edge is used only when making a cut with a circular saw (not the router).

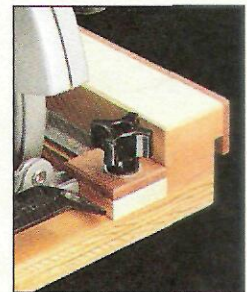
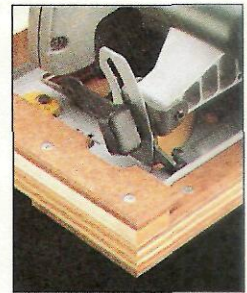
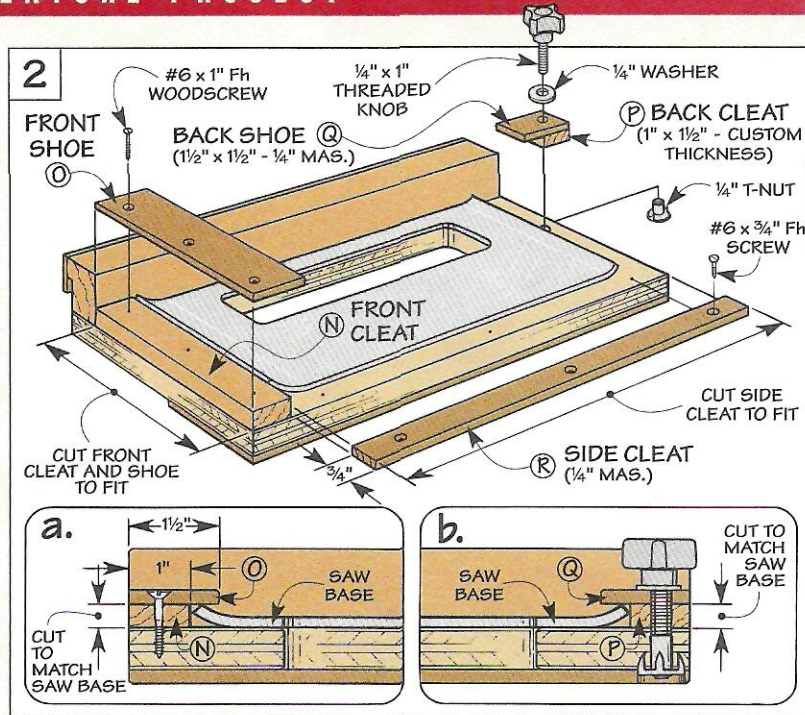

Depending on your saw, you may need to modify the front or back brackets.

## Router Carriage

Like the saw carriage, the router carriage has a base that supports the tool. But to provide maximum depth adjustment for the bit, this *base* (S) is made from 1/4"-thick Masonite, see Drawing.

Here again, a *rail* (T) and a *keeper strip* (U) combine to track the carriage on the fence. Only this time, you'll need to allow for the difference in thickness between the two bases.

This is just a matter of making the rail taller (wider) and the rabbet wider, see Detail. As before, a Masonite *foot* (V) is glued to the base to keep the carriage level.

**MOUNT ROUTER.** When mounting the router, don't forget to provide some knuckle room between the handles and the rail. The simplest way to do this is to mount the router so the handles are at a 45° angle to the rail.

To locate the holes for the bit and the mounting screws, it's easiest to remove the plastic base on the router and use it as a template. Then drill counterbored shank holes for the screws and attach the router to the carriage.

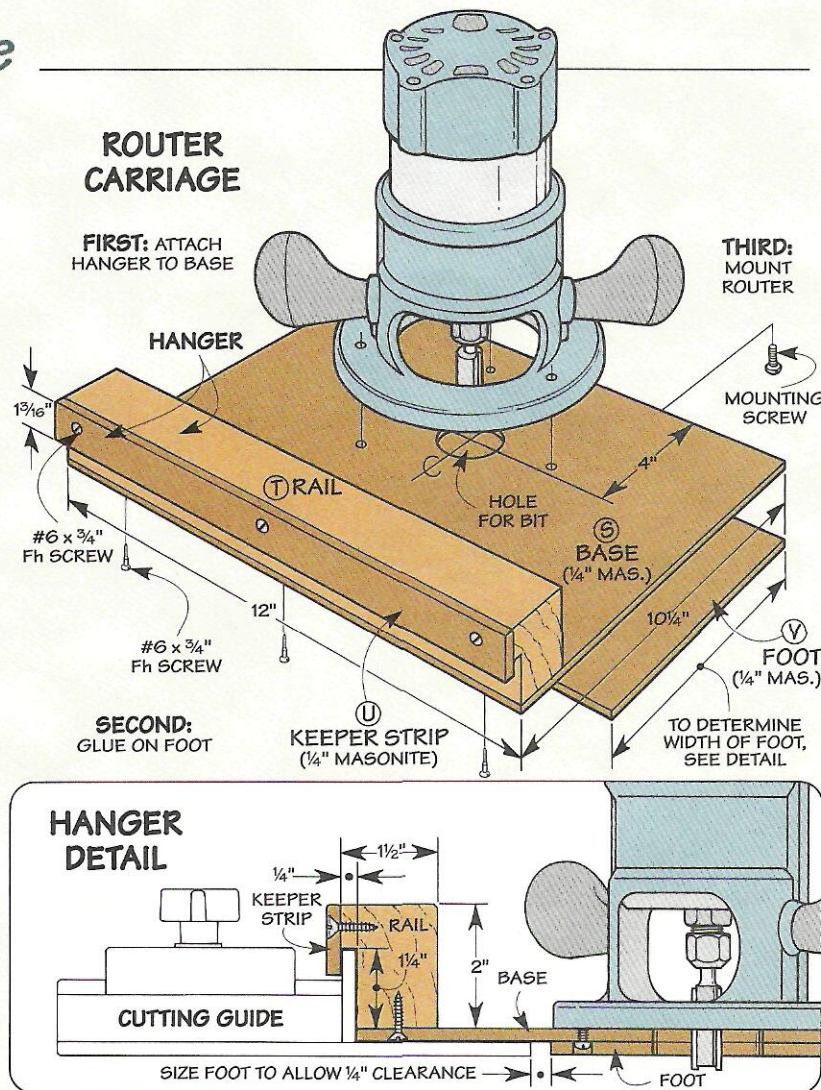



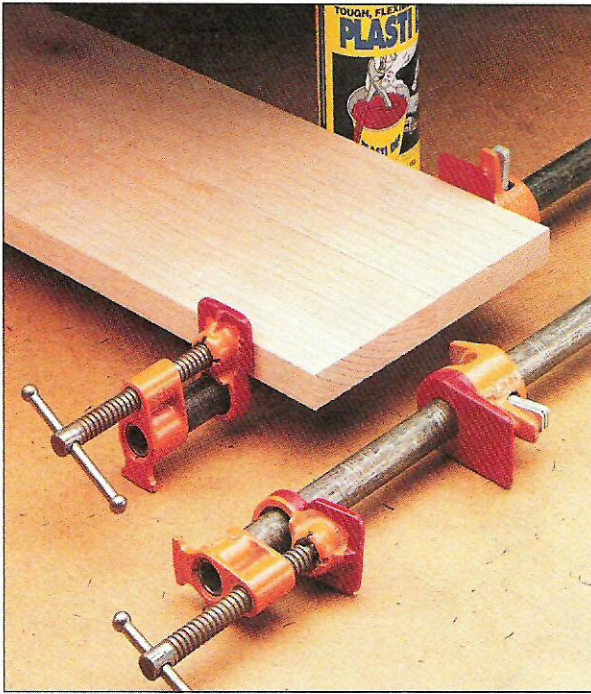

# Pipe Clamp Tips

*The secret to using pipe clamps is to plan ahead. Here's a collection of our favorite tips that will solve the most common problems you're likely to encounter.*

## Clamp Pads

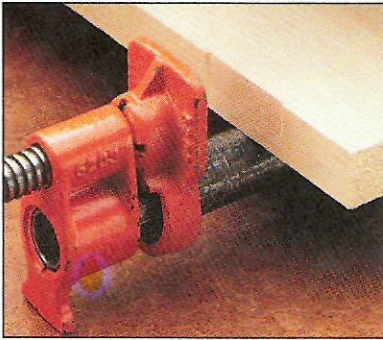

**Clamp Marks.** A common problem with pipe clamps is it's all too easy to apply too much pressure and crush the workpiece.

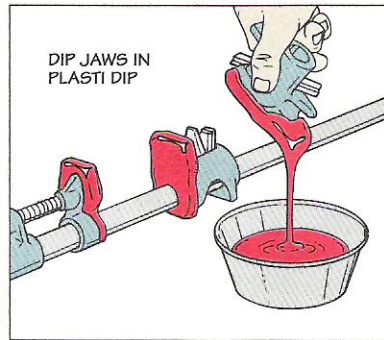

**Plastic Padding.** One way to pad the jaws of a pipe clamp is to dip them in Plasti Dip (available at most hardware stores).

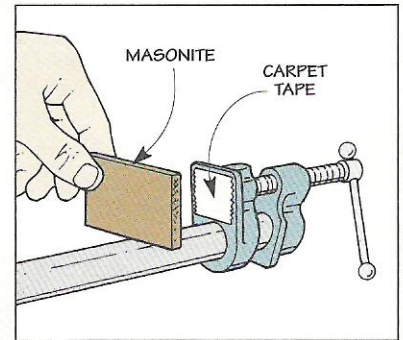

**Wood Padding.** Another simple way to pad the jaws is to attach a small piece of Masonite (or scrap wood) with carpet tape.

## Preventing Stains

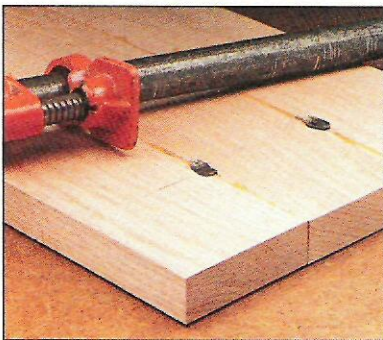

**Stained Wood.** Pipe clamps can discolor a glued-up panel when the iron in the pipe comes in contact with the wet glue.

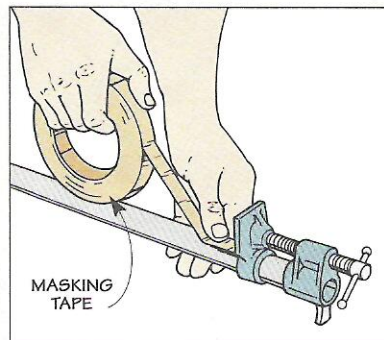

**Masking Tape.** The quickest and easiest way to prevent discoloration is to isolate the pipe from the wood with masking tape.

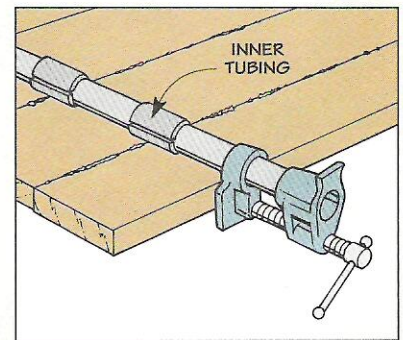

**Inner tubes.** A more permanent solution to preventing stains is to slide lengths of bicycle tire inner tubing over the pipe.



## Clamp Extenders

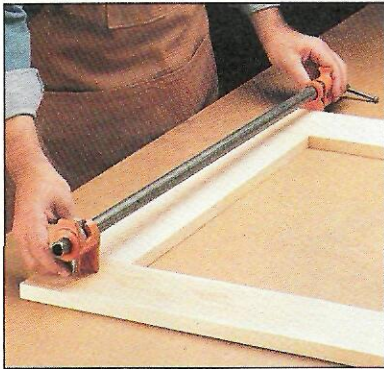

**A Short Reach.** Sometimes the pipe clamps you have on hand just aren't long enough to reach all the way across the project.

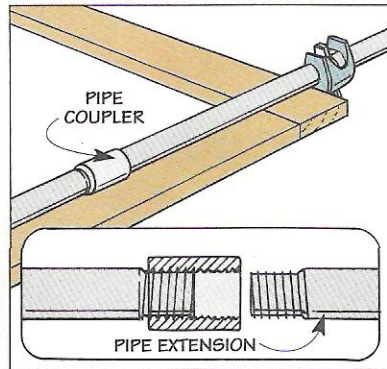

**Pipe Coupler.** You can extend the reach of a pipe clamp by adding a pipe coupler and an extra length of threaded pipe.

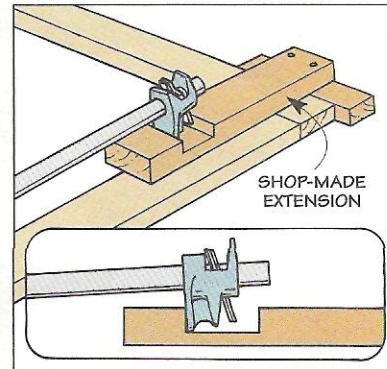

**Shop-Made Extension.** Or you can build a simple wood extension. It's shaped like a "T" and is notched to accept the clamp.

## Flat Panels

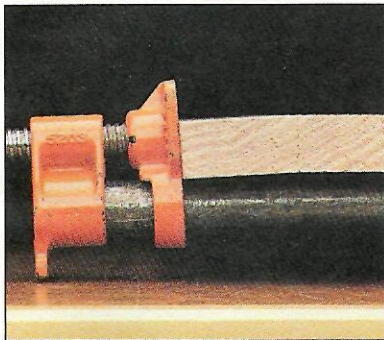

**Uneven Pressure.** As you tighten down the pipe clamps, the jaws exert uneven pressure which can cause the panel to bow.

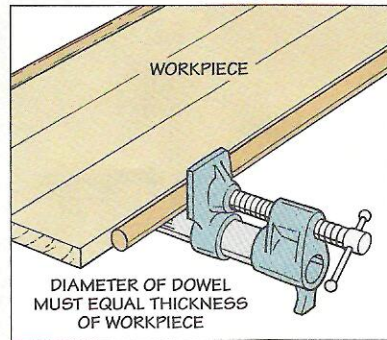

**Dowel Rods.** To compensate for this and center the clamping pressure, slide a dowel rod between the jaw and the workpiece.

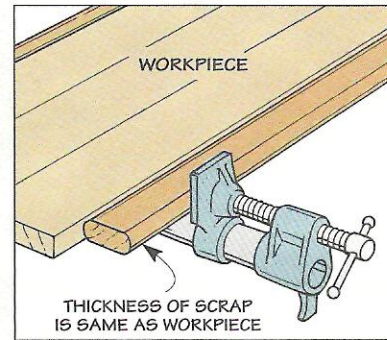

**Shop-Made Strips.** If you don't have dowel rods handy, round over scraps that are the same thickness as the workpiece.

## Pipe Clamp Spreader

It doesn't happen very often, but occasionally we'll have to break apart a freshly glued-up case or separate the rungs from the legs of an old chair in need of repair.

The best method I've found for doing this is to convert a pipe clamp into a pipe clamp spreader.

To do this, first reverse the jaw with the handle so it can push outward instead of inward. Then to provide a runner for the jaw to travel on, thread a short length of pipe in the threads of the jaw.

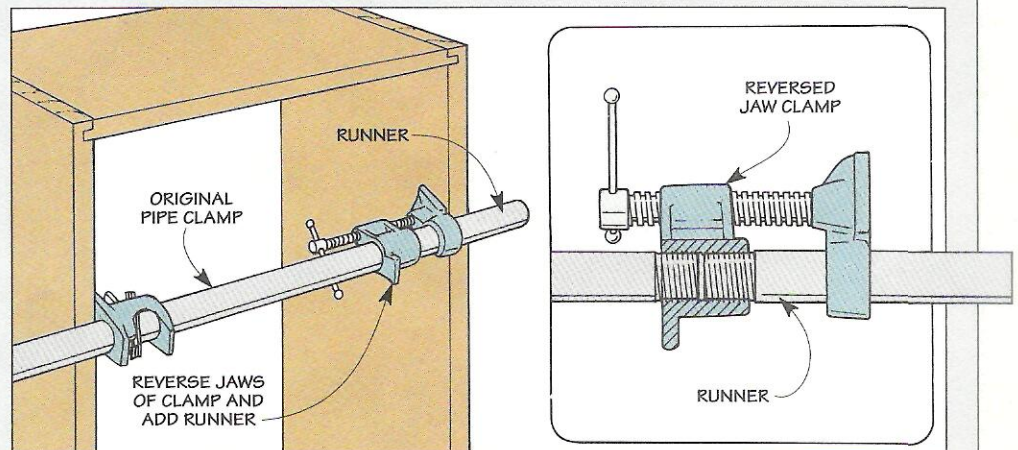



# Routing Profiles

## with a Hand-held Router

*Five simple steps to create perfect profiles with a hand-held router.*

One of the quickest and easiest ways to create a decorative edge on a workpiece is to use a hand-held router. And the secret to routing a clean, chip-free profile is to use a simple step-by-step technique, see box on opposite page.

### SECURE WORKPIECE

The first step to routing a decorative edge is to secure the workpiece to a bench or work surface. The obvious choice would be to clamp it in place. But since a router has to ride on the surface of the workpiece, the clamps often get in the way.

If you own a workbench with bench dogs, the solution is simple. Just set the dogs slightly below the surface of the workpiece and adjust the vise to hold it secure. If you don't, you can clamp each end of the workpiece to your bench. Then rout up to the clamps, move them, and continue routing.

### ROUTER SUPPORT

In addition to securing the workpiece, you'll also need to keep the base of the router level and flat as it rides over the surface. If you don't, the router can tip and gouge the workpiece. Fortunately, there are a couple of ways you can prevent this.

One method is to carpet tape a scrap block to the base of the router, see Fig. 1. The scrap acts as an outrigger to support the router base during the cut.

Another way to provide support when routing the thin edge of a workpiece (where it's too narrow

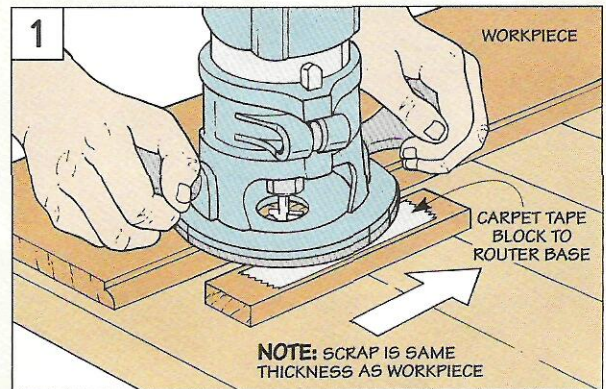

to balance the router), is to temporarily build up the edge by clamping a scrap to the workpiece, see Fig. 2.

### PILOT-GUIDED BIT

Once you're sure the workpiece is secure and the router is steady, the next step is to select a bit. To make a controlled cut when routing decorative edges, I use a pilot-guided bit, see box on page 23.

For the profile to be uniform, the thing to keep in mind is the pilot must be in contact with the wood at all times. So try to anticipate the curves and corners and keep the pilot pressed firmly against the board's edge. Also, for the best contact, make sure the edges of the board are smooth.

Note: When using a pilot-guided bit, be careful when you make cuts that remove most or all of the edge. This leaves little or no material for the bear-

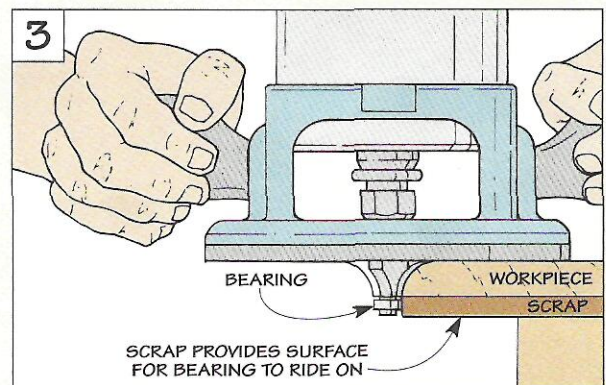
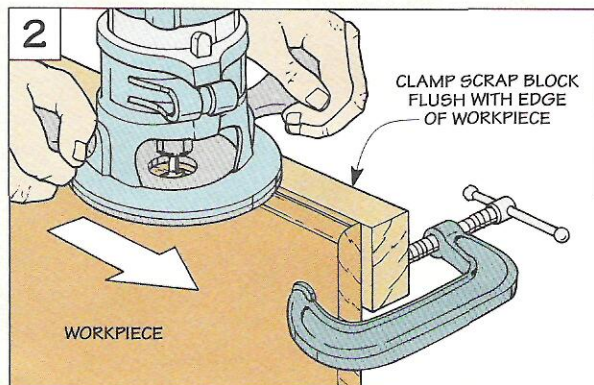



ing to ride on. To get around this, leave at least 1/16" of material for the pilot to ride on. Or place a scrap piece under the workpiece, see Fig. 3.

**DIRECTION & SEQUENCE**

Besides the bit, the direction that you feed the router also affects the quality of the cut. The general rule is: outside edges — rout counterclockwise, inside edges — rout clockwise, see Fig. 4.

The other thing that's important to do is take a minute to look at the *grain* direction. To prevent chipout, rout in the same direction as the grain when possible and pay particular attention to areas where the grain appears to change direction.

The sequence you use to rout the edges can also prevent chipout. Since end grain is unsupported at the edge of a board, you'll need to take care to prevent it from chipping out.

One solution is to support the end grain by temporarily clamping a piece of scrap to the workpiece, see Fig. 5. Another method is to make the end grain cuts *first* (and allow it to chip out), then clean up the corner when you rout the edge grain.

**LIGHT CUTS**

But one of the most effective ways to ensure the profile is smooth and consistent is to take a series of light cuts. By taking smaller "bites," there's less chance of the wood chipping out.

One way is to start with about one third of the cutting edge exposed. Then make a cut and gradually expose more bit until the full profile is reached.

Another way is to start with the bit set for a full cut. Then use shims (such as 1/4" Masonite) to reduce the depth of cut, see Fig. 6. The shims are carpet-taped to the base of the router and removed a layer at a time between cuts, see Fig. 6a.

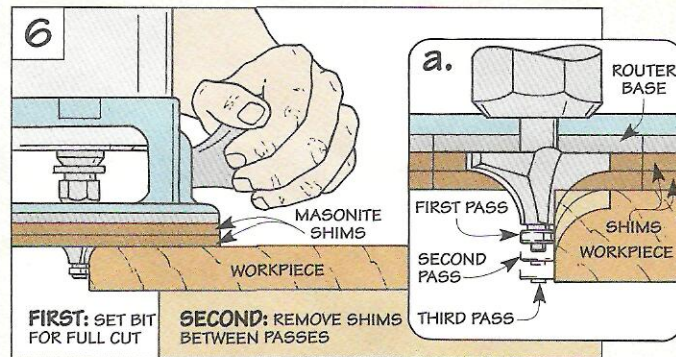
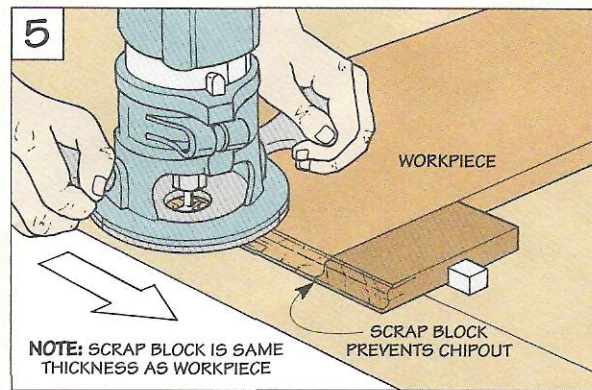
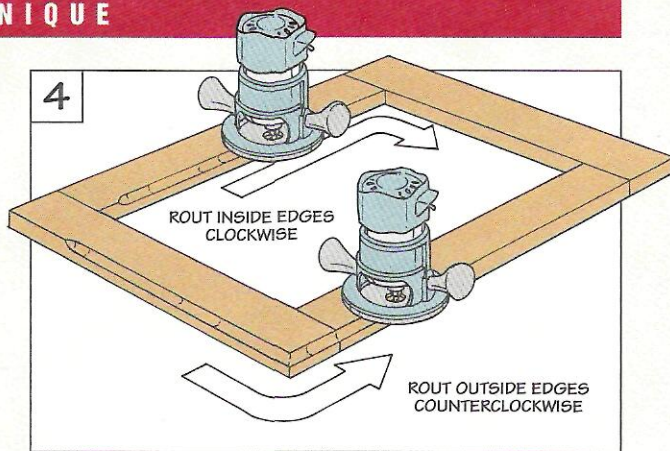

**Pilot-Guided Bits**

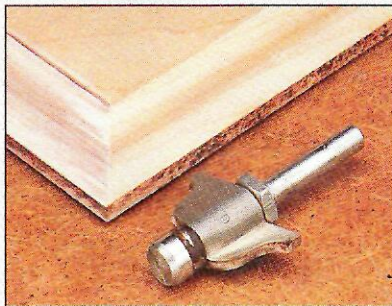

▲ **Solid Pilot.** As a solid pilot rubs against the edge of the workpiece during a cut, it tends to burn or burnish the surface.



▲ **Ball-Bearing Pilot.** But when a ball bearing pilot rides along the edge, the bit spins freely inside and leaves a clean edge.

**Perfect Profiles**

- 1 **Secure the workpiece.** Start by securing the workpiece to your bench with clamps or bench dogs.
- 2 **Support the router.** Next, use an outrigger or scrap block to support the router and prevent it from tipping.
- 3 **Use a pilot-guided bit.** To control the cut as you rout, use a bit that has a ball-bearing pilot.
- 4 **Rout in correct direction.** For a safe cut that also prevents chipout, rout in correct direction and sequence.
- 5 **Take light cuts.** To ensure a smooth and consistent profile, take light cuts and sneak up on the final depth.



# Clamp Storage System

*Most clamp racks are designed by other woodworkers for their own clamps. This organizer can be customized for your clamps.*

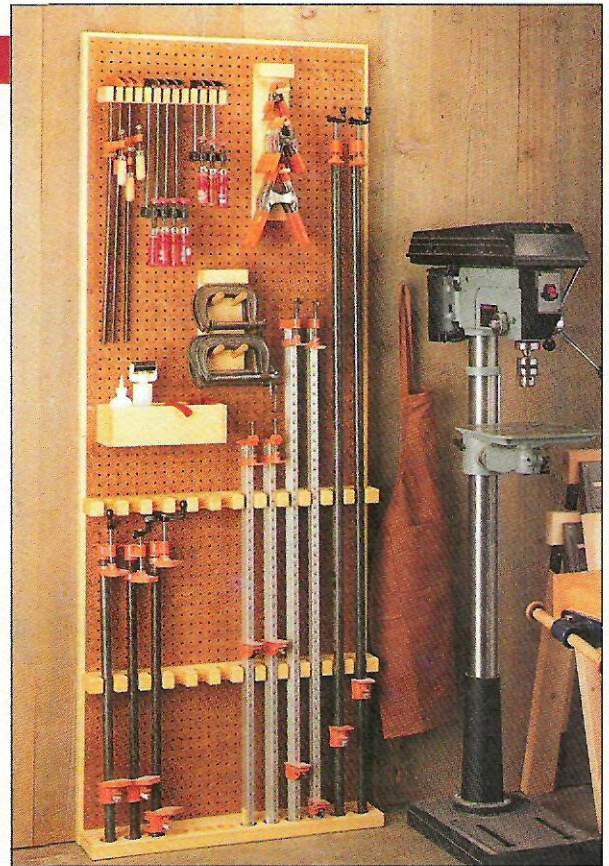

One of the problems I've had with clamp racks is they're always designed for someone else's clamps. But not this clamp organizer. It's a modular system that can be customized to store the clamps *you* have.

The heart of this system is a pegboard frame. It mounts to the wall and accepts custom hangers designed to fit your clamps.

**CUSTOM HANGERS.** The hangers hold bar clamps, C-clamps,

and spring clamps. There's even a storage box for odd-shaped clamps, glue bottles, and brushes.

**L-HOOKS.** Each hanger has L-hooks screwed into the back. The advantage of using L-hooks is they can't fall off or pull out of the pegboard like traditional pegboard hooks, see box below.

## CONSTRUCTION

I started on the clamp storage system by building a frame to

hold the pegboard. It consists of identical *top* (A) and *bottom* (B) pieces, and two *sides* (C), see Figs. 1 and 2. (I used "two-by" dimension lumber.)

**RABBET.** To hold the pegboard, a 1/4"-deep rabbet is cut along the inside edge of each frame piece, see Figs. 1a and 1b. (I used a dado blade in the table saw.)

**JOINERY.** The frame pieces are held together with a simple rabbet joint. The rabbets are cut in the ends of the sides to accept the top and bottom, see Fig. 1b. Then the sides are screwed to the ends of the top and bottom.

**PEGBOARD.** After the frame is assembled, it's ready for the *pegboard* (D). But before cutting the pegboard to fit, there's one thing to keep in mind.

Since it's easiest to screw through the holes that are already drilled in the pegboard, make sure the holes along the outside edges align with the center of the rabbet in the frame.

To complete the rack, soften the edges by routing a chamfer along the outside edges.

## Improved Pegboard Hooks

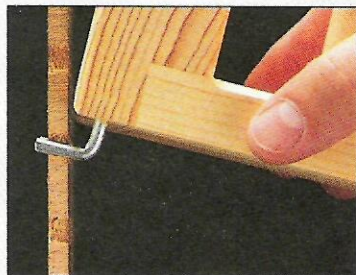

**Tilt Hanger.** Installing a clamp hanger is easy. First, tilt it so the L-hooks can slide into the holes of the pegboard.

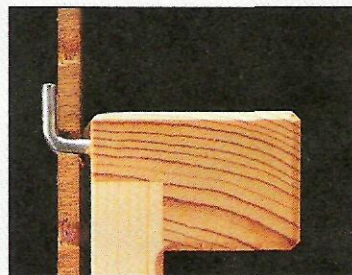

**Lock It.** Then lower the hanger against the pegboard to lock the L-hooks in place. Now the hanger can't fall off or pull out.



At this point, you can either mount the pegboard rack to the wall and start building the clamp hangers. Or if you have pipe clamps or large bar clamps, build the rack below and mount it to the frame before attaching it to the wall.

**PIPE CLAMP RACK**

The pipe clamp rack is designed to hold pipe clamps and large bar clamps. It consists of three parts: a support base that keeps the clamps up off the floor, and two cradles that separate the clamps, see Fig. 2.

**SUPPORT BASE.** I started building the pipe clamp rack by cutting the support base (E) from “two-by” material, see Fig. 2.

To provide a “pocket” for the end of each clamp to rest in, lay out and drill a series of holes in the base, see Fig. 2. Note: In order for the clamps to lean into the cradles, I drilled these holes at a 5° angle, see Fig. 2a.

Now you can complete the base by routing a chamfer on all the exposed edges and the rim of each hole, see Fig. 2.

**CRADLES.** To build the cradles (F), start by cutting two pieces of “two-by” lumber to size. The easiest way to make sure the slots align in both cradles is to carpet tape them together before drilling the holes.

Then remove the waste with a sabre saw or band saw. And chamfer all the exposed edges.

**MOUNT RACK.** Unlike the other hangers, the pipe clamp rack is screwed to the pegboard and frame. This helps distribute the weight of the clamps.

And by mounting the support base at the bottom, the weight from the pipe clamps will be transferred directly to the floor.

Now the pegboard frame can be mounted to the wall with the pipe clamp support base resting directly on the floor.

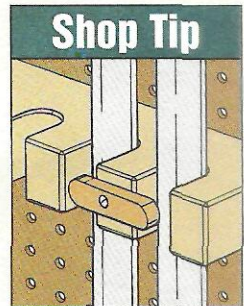
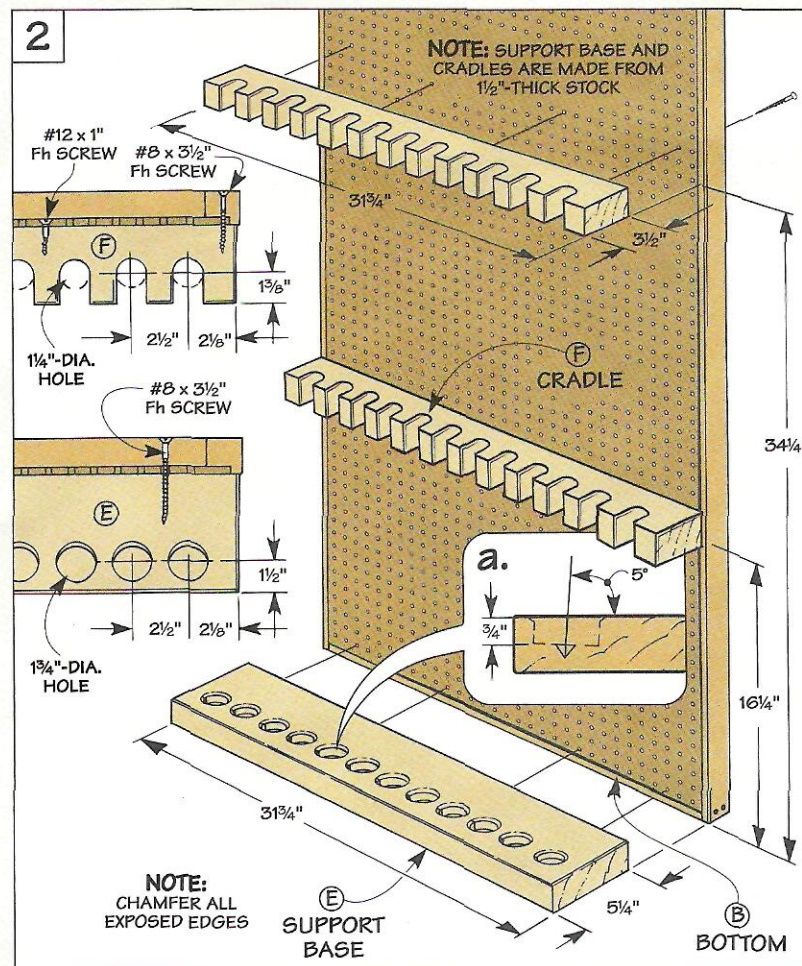
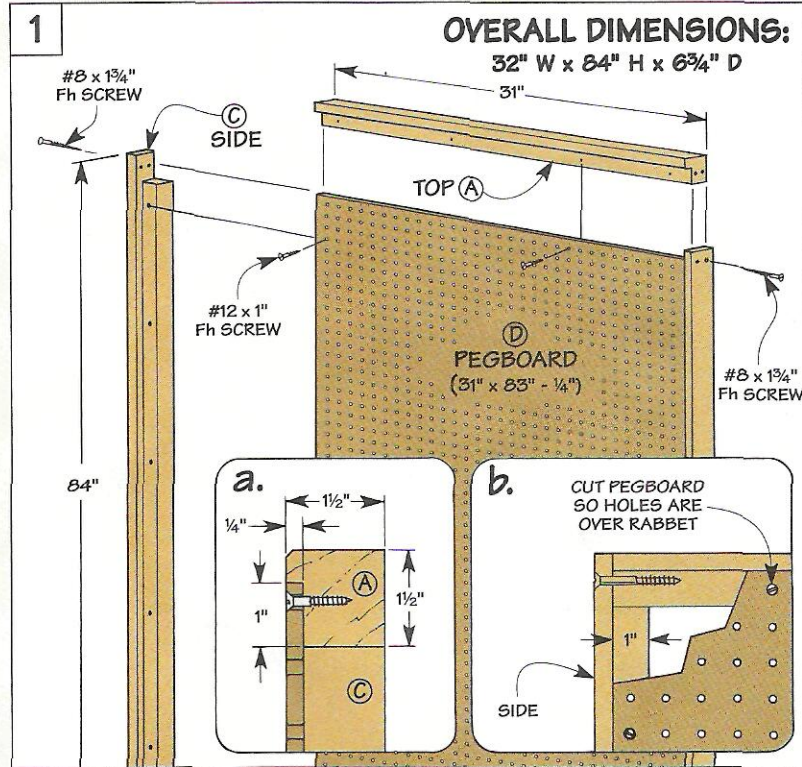

To “lock” your pipe clamps in place, add a simple turnbuckle.



## C-Clamp Hanger

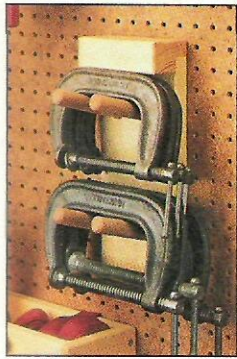

The wood pegs on this hanger make it easy to slip your C-clamps on or off.

Storing C-clamps has always been a challenge. This hanger lets you slip them on or off without having to open or close the clamps. It consists of a base, a head, and four pegs to hold the clamps, see Fig. 3.

The base is a piece of  $\frac{3}{4}$ "-thick stock with four  $\frac{3}{4}$ " holes to accept the pegs. To prevent the clamps from sliding off the hanger, I drilled the holes at a  $10^\circ$  angle, see Fig. 3a.

The base attaches to the peg-board by way of the head. It's  $2\frac{1}{4}$ " wide to provide plenty of room for the L-hooks to screw into. And it's rabbeted in the back to fit over the base.

To assemble the hanger, just glue and screw the head to the base. Then glue in four  $\frac{3}{4}$ "-dia. dowels for the pegs and attach the L-hooks, see Figs. 3a and 3b.

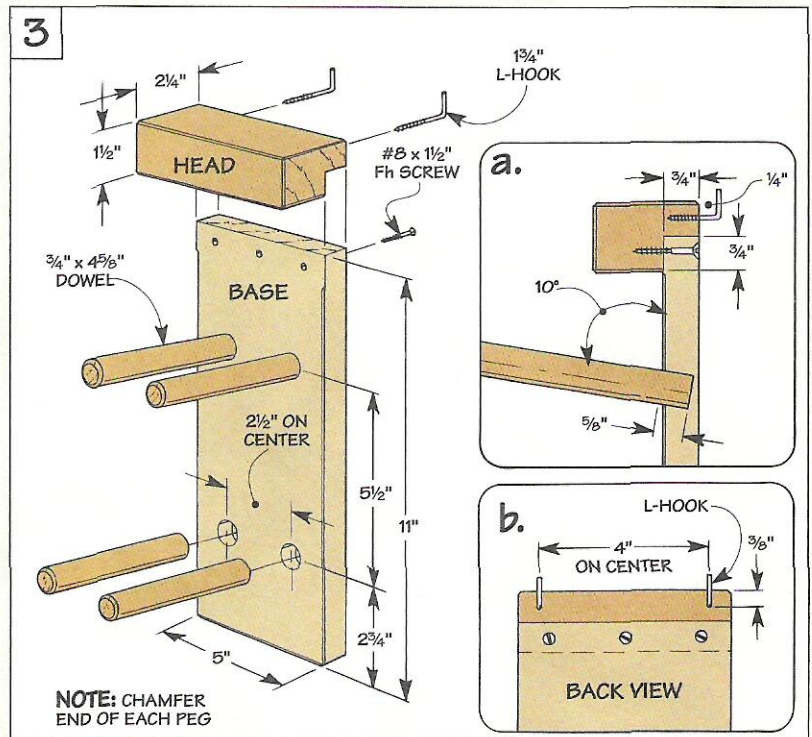

## Spring Clamp Hanger



To save space, this spring clamp hanger is designed to "nest" your clamps.

The construction of the spring clamp hanger is similar to that of the C-clamp hanger, see photo at left. But there are only three pegs instead of four. And the base is slightly longer to accommodate three sizes of spring clamps, see Fig. 4.

Also, because spring clamps don't weigh as much as C-clamps, I used a smaller diameter peg ( $\frac{1}{2}$ "-dia.) instead of the stouter  $\frac{3}{4}$ "-dia. pegs that were used for the C-clamp hanger.

Since the rubber tips of the spring clamps prevent the clamps from slipping off the hanger, I drilled the holes for the pegs straight into the base.

And to allow the space on the hanger to be used the most efficiently, position the pegs in such a way that the smaller spring clamps "nest" over the larger spring clamps. Then complete the hanger by adding the L-hooks to the back of the head.

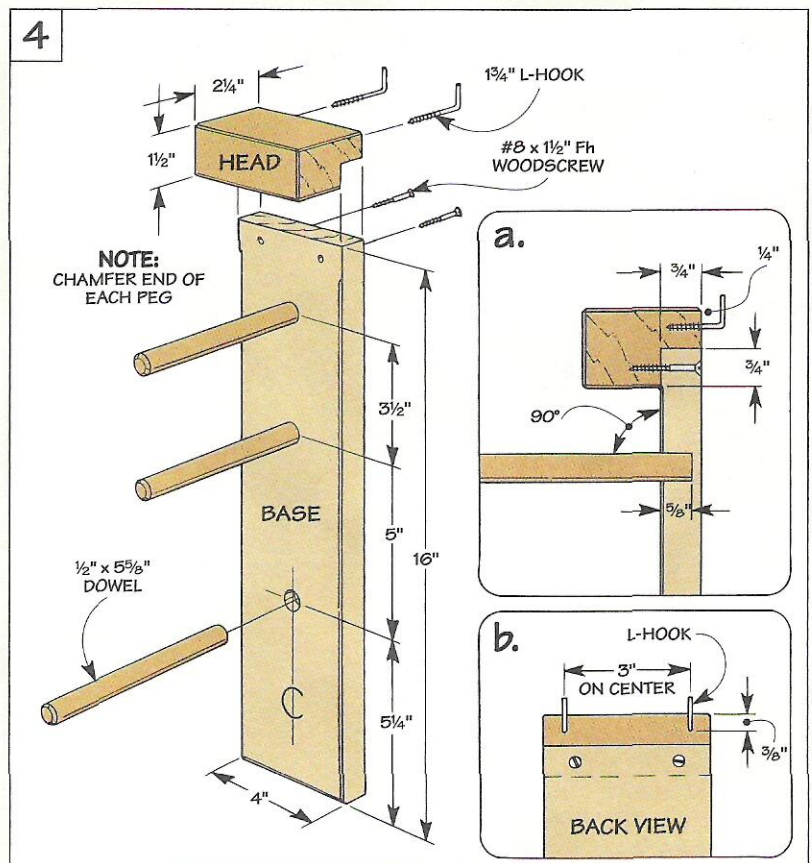



# Bar Clamp Hanger

Most bar clamp hangers I've seen require that the jaws of the clamp be closed before the clamp can be hung on the rack. This hanger eliminates that.

The base of the hanger is a short piece of "two-by" stock with a series of slots in the front, see Fig. 5. The slots are wide enough to hold most of the bar clamps we use in our shop.

To reinforce the narrow tongues created by the slots, I glued a top piece cut from 1/8"-thick Masonite to the base before cutting the slots.

After the slots are cut, file or sand a chamfer on the front corners of each tongue to help guide the clamp into the slot and prevent it from getting chewed up.

Then to complete the hanger, install the L-hooks, see Fig. 5a.

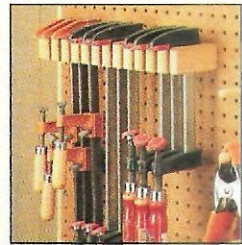
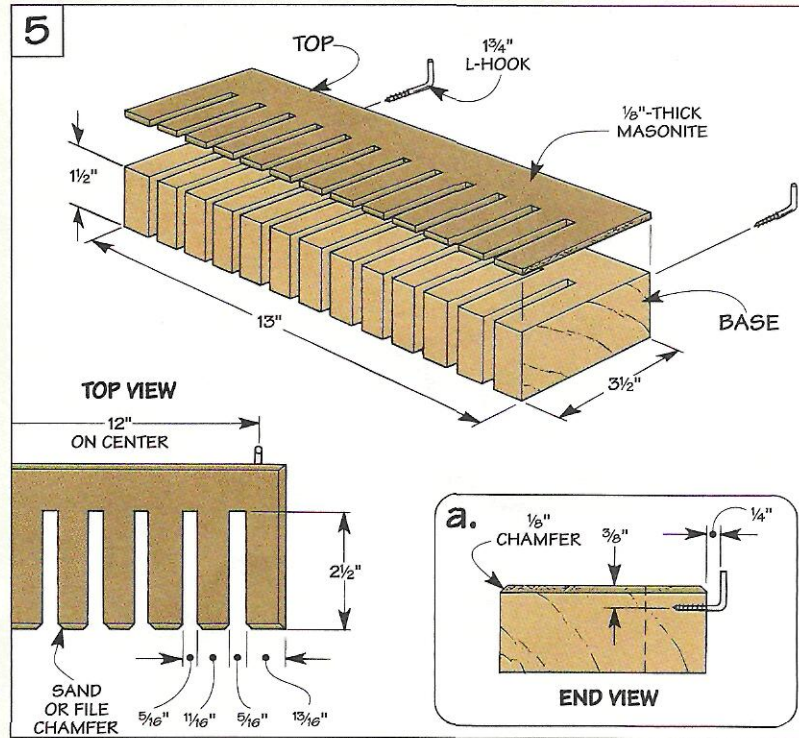

To hang a bar clamp on this hanger, just slide down the bottom jaw and slip the clamp in place.

# Storage Box

If you're like me, you have a number of odd-shaped clamps that can't be hung on a conventional clamp hanger — clamps like band clamps, toggle clamps, and angle clamps. And other glue-up supplies like bottles of glue, brushes, and rags you like to keep handy.

To provide a convenient place for all of this, I built a simple storage box. The box is constructed from 3/4"-thick pine and 1/8"-thick Masonite. And it's held together with rabbets and countersunk screws, see Figs. 6 and 6b.

The rabbets on the ends are cut to fit the front and back of the storage box. And a groove is cut near the bottom of all four pieces to hold a bottom made of 1/8"-thick Masonite, see Fig. 6a.

Once the box is glued and screwed together, rout or sand a chamfer around the inside and outside top edges. Finally, install the L-hooks (they go into the ends) and hang up the box.

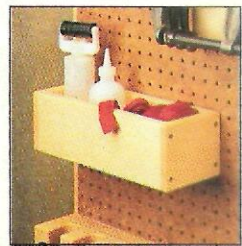
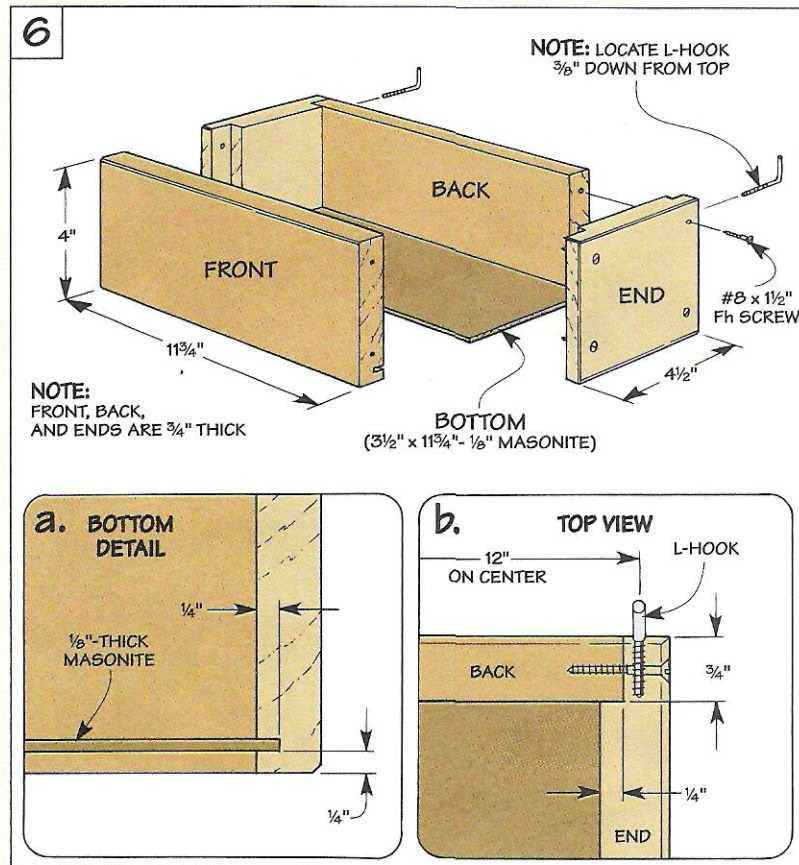

This storage box is perfect for storing odd-shaped clamps and glue-up supplies.



# Shop Solutions

## Router Biscuit Jig

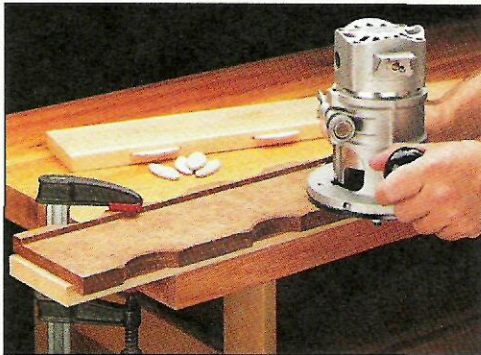

■ I like the idea of using biscuits to edge join two boards. But I can't afford a biscuit joiner. So I made a simple jig for my router that uses a slot cutting bit to create the slots.

The jig is easy to make. It's a double layer of Masonite with scalloped edges, see Drawing. (I cut the scallops with a jig saw and used a drum sander to smooth them out.) This way as the bearing on the slot cutting bit follows the scallop pattern it cuts a perfect slot. (In my case, I use a 2"-dia. bit with a 1"-dia. bearing to cut a slot for a #10 biscuit.)

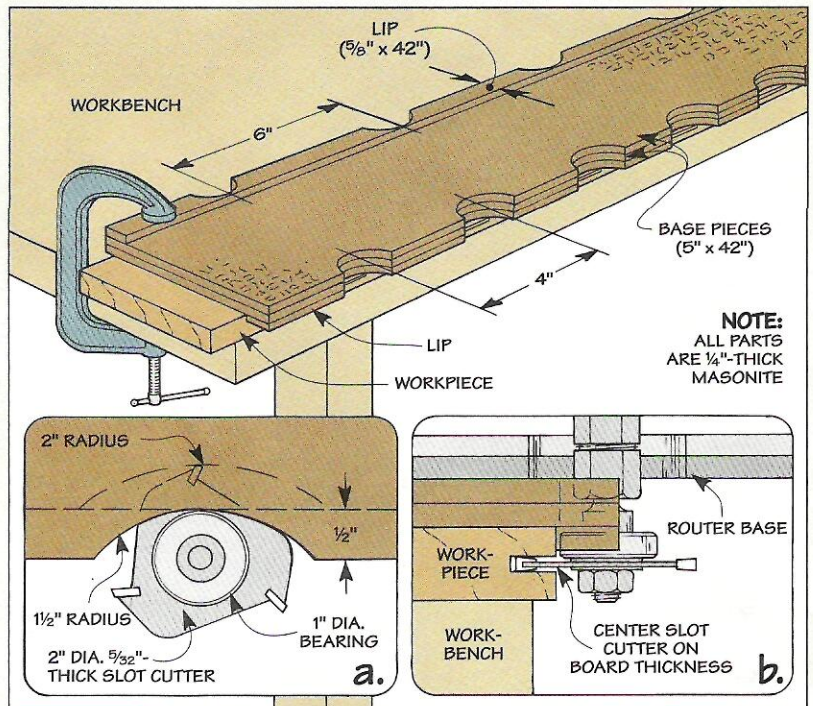

I made the jig with two scalloped edges to provide a variety of spacing for the biscuits. The scallops along one edge are spaced 4" apart. But the scallops on the other edge are 6" apart.

A lip glued to the bottom, serves as a stop. It automatically positions the jig on the workpiece for the correct depth every time.

*R. Brucken  
Martinez, California*

## Add-On Dust Collector

■ My band saw creates a lot of fine dust each time I use it (especially when resawing). So I made a dust collector to vacuum up most of the dust as it comes out under the table, see Drawing.

The dust collector consists of two pieces of plywood and a length of PVC pipe. Install the PVC pipe in one piece of plywood. And cut a hole in the other piece for your vacuum hose. Then glue the pieces together and attach the collector to the band saw.

*Pres Kimball  
Lebanon, Oregon*

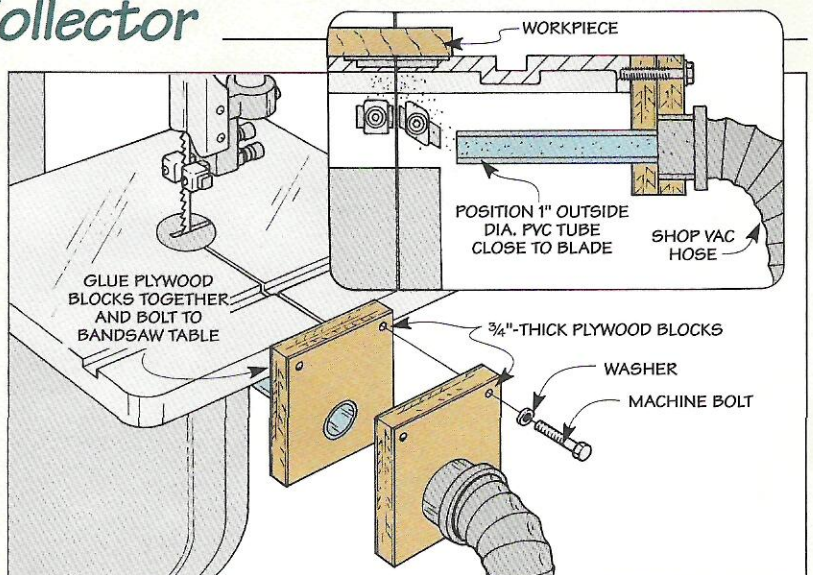



## Workmate Roller Support

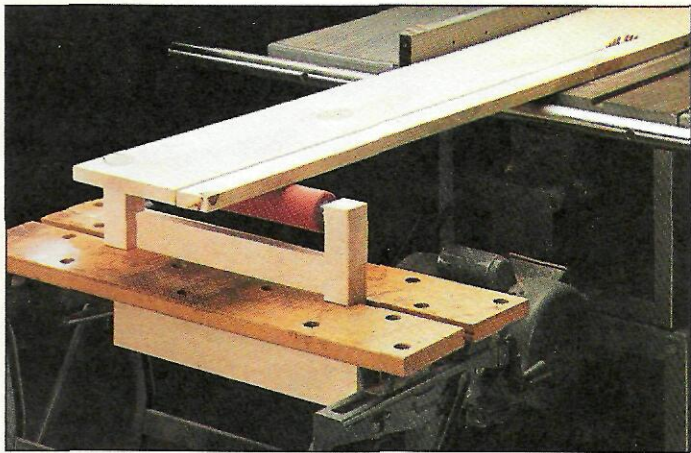
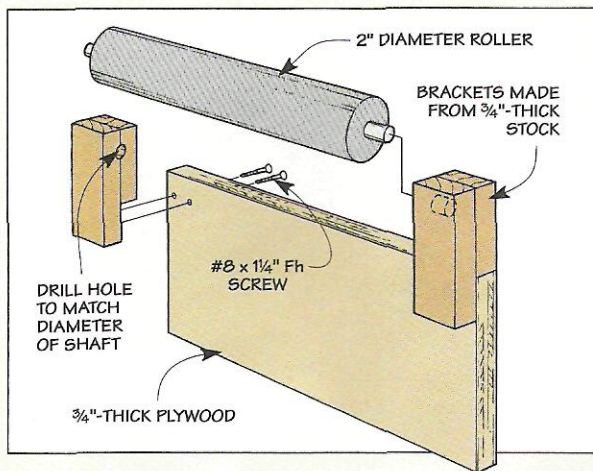

■ I always have problems cutting large pieces of plywood or long boards on my table saw. Not for most of the cut — just the last few inches when it's unsupported.

To solve this problem, I made

an outfeed support that fits into my Workmate. (*Editor's Note: Or you can clamp it to a sawhorse.*) The support is a roller attached to a piece of plywood with a pair of wooden brackets, see Drawing.

I used a roller from a copy machine. (Check local print shops or copy machine stores). But a typewriter roller would also work.

*Bill Paulson  
Marietta, Georgia*

## Cord Protector

■ My table saw sits in the middle of my shop. That makes the power cord that runs across the floor a real hazard. It seems I'm always tripping over it or dropping something heavy on it.

So I made a protector for it. It's just a piece of wood with a groove in the bottom for the cord. The top is beveled so you don't catch your foot. And a Masonite piece holds the cord in the groove.

*David Krusey  
Ripon, Wisconsin*

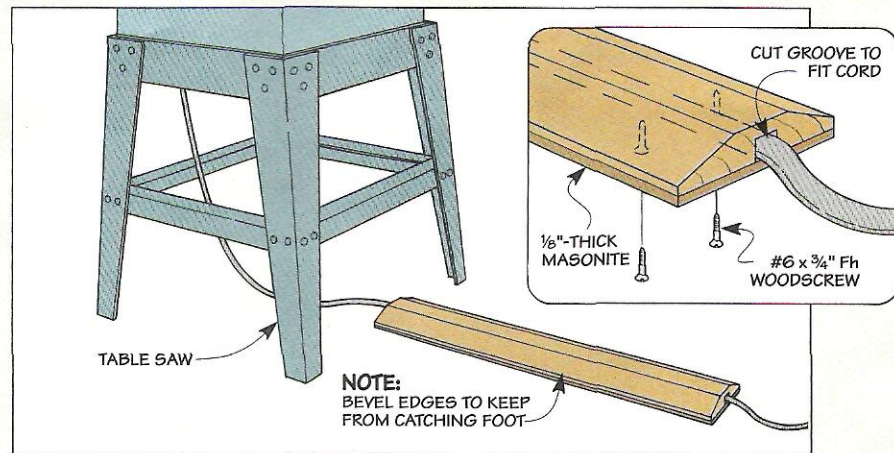

## Quick Tips

■ I have a lot of "short" scraps that are just too long to throw away. So I made a storage bin out of plastic buckets (the kind dry-wall compound comes in). I stack them pyramid style and bolt them together. Then add a plywood base to tilt the buckets and keep the pieces from falling out.

*Joe Coffey  
Alamo, California*

■ Forstner bits can be difficult to line up when starting a hole. That's because the centerpoint on the bit is so hard to see.

To solve this problem I use a template and draw a full circle — not just the centerlines. Then all I have to do is line up the rim of the bit with the circle.

*Bill White  
Williston, Vermont*

## Send in Your Solutions

If you'd like to share your original solutions to problems you've faced, send them to: *ShopNotes*, Attn.: Shop Solutions, 2200 Grand Avenue, Des Moines, IA 50312. (Or if it's easier, FAX them to us at: 515-282-6741.)

We'll pay up to \$200 depending on the published length. Please include a daytime phone number so we can call you if we have questions.



# Lumber Grain



The key to identifying lumber grain is “reading” the end of the board.

■ When buying hardwood, I have a hard time telling the difference between flatsawn, riftsawn, and quartersawn lumber. Is there a simple way to do this?

Jerome Lewis  
Manhattan, Kansas

The simplest way to tell the difference is to look at the *end* of the board. What you’re looking for is the *angle* of the growth rings. This angle is determined by how the lumber was cut, see Drawing.

**FLATSAWN.** On flatsawn lumber, the rings will be 30° (or less) to the face of the board, see below. In many cases, especially with boards coming from large diameter logs, the rings will be parallel to the face.

Flatsawn lumber is the most common type of lumber you’ll come across because a log yields the most lumber when cut this way. Because of this, it’s the least expensive cut available.

But flatsawn lumber tends to move a lot with changes in humidity — it often cups or warps. And the grain swirls in many directions over the face of the board.

When this wild-grained wood is stained, the softer, more porous early wood will soak up more stain and look darker than the harder, less porous late wood.

**RIFTSAWN.** When I’m sorting for more attractive boards, I’m looking for riftsawn lumber. In this case, the growth rings are

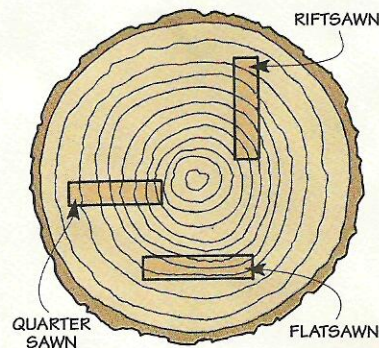

greater than 30°, but less than 60° to the face of the board, see below.

Riftsawn lumber generally has straighter, clearer grain than flatsawn lumber. Usually, riftsawn lumber is mixed right in the same stack as flatsawn lumber.

In fact, many *boards* in a flatsawn stack will have both riftsawn and flatsawn grain. When a

single board has both types of grain, what you’ll actually see is wild grain running right along-side nearly straight, clear grain.

Another reason I look for riftsawn wood is for its stability — it’s less likely to warp or cup than flatsawn lumber.

**QUARTERSAWN.** The straightest grain comes from logs that are quartersawn. Here, the growth rings will be 60° to 90° to the face of the board, see below.

In addition to really straight grain, some hardwoods (such as red and white oak, cherry, and hard maple) exhibit highly figured face grain (ray flecks) when quartersawn. And when finished, these woods can be quite striking.

Also, when the humidity does change, quartersawn lumber is the most stable of the three different cuts of lumber.

The downside to quartersawn lumber is it requires larger logs to produce reasonably wide boards. And since there’s more waste, it’s the most expensive.

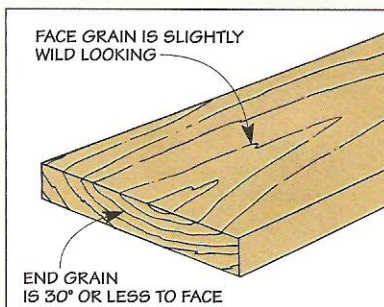

**Flatsawn.** On flatsawn lumber, the growth rings are 30° (or less) to the face of the board. The grain is the wildest of the three cuts.

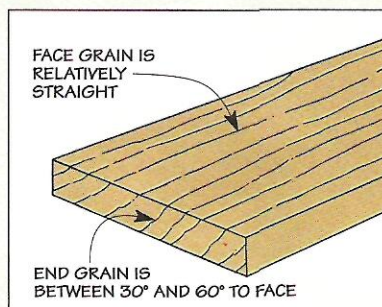

**Riftsawn.** With riftsawn lumber, the growth rings are greater than 30°, but less than 60°. The grain runs fairly straight across the face.

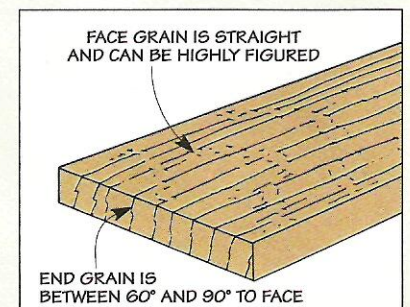

**Quartersawn.** The growth rings on a quartersawn board are 60° to 90°. On certain hardwoods, the face grain is highly figured.



# Danish Oil

The visitors to our display area here all have one thing in common. As they browse through the projects, they run their hands over the surface of the wood. Especially the projects finished with a Danish oil.

The reason is simple. Danish oil penetrates *into* the wood fibers. So unlike some finishes, it leaves the wood looking *and* feeling as natural as possible.

But there's more to Danish oil than just good looks. It's hard to imagine a finish that's easier to apply. A look at what's inside explains why.

**INGREDIENTS.** Even though there are a number of different brands (like Watco, Deftoil, and Nordic Oil Finish), most Danish oils have three basic ingredients.

To produce a satin sheen, there's a natural *oil* (like linseed or tung oil). Because these oils are slow-drying, you have plenty of time to work the finish. Next, to allow the oil to penetrate, it's thinned with *solvents*. Then *resins* are added to create a harder finish. Note: Some manufacturers also add pigments to color the oil.

Even so, a Danish oil finish still doesn't offer as much protection as other topcoats. So it's best to use on projects that won't get a lot of wear. For example, a clock, display cabinet, or wall mirror.

## APPLICATION

Regardless of the project, there's nothing complicated about applying a Danish oil finish.

**FLOOD SURFACE.** The first step is to use a brush (or rag) to flood the surface, see photo A. The important thing is to give the oil

time to soak in. (This varies depending on the brand.) If you notice dry spots, apply more oil — especially on end grain that absorbs the oil like a sponge.

**REMOVE EXCESS.** Now simply wipe the surface of the wood “dry,” see photo B. Leaving oil on the surface creates a soft, gummy layer that won't make the finish any more durable.

The only problem is the oil that remains in the pores of the wood

*Danish oil penetrates into the wood fibers. So it leaves the surface looking and feeling natural.*

can still “wick” back out and form small puddles (especially on wood with large open pores like oak or ash). To keep these puddles from hardening into rough scabs, I check the project every hour or so and wipe off any oil that seeps out.

**ADDITIONAL COATS.** As a rule, you'll need to apply several coats of oil. To produce as smooth a finish as possible, I sand in between coats

with fine (220-grit) sandpaper.

As an option, some manufacturers recommend using Wet-or-Dry silicon carbide paper (600-grit) to sand in the oil, see photo above. This forms a thin paste that's wiped off as before.

**SAFETY NOTE.** As you clean up, the thing to be aware of is the oil gives off heat as it cures. This can cause a pile of oily rags to spontaneously combust. So I spread the rags out on the floor and throw them away when they're dry.

**REPAIRS.** A last note about Danish oil. You can repair it if it gets damaged. Small scratches can be “blended in” by applying another coat of oil. (Just be sure to remove any grime or wax with mineral spirits first.) If the scratches are more severe, sand lightly around the damaged area and apply another coat.

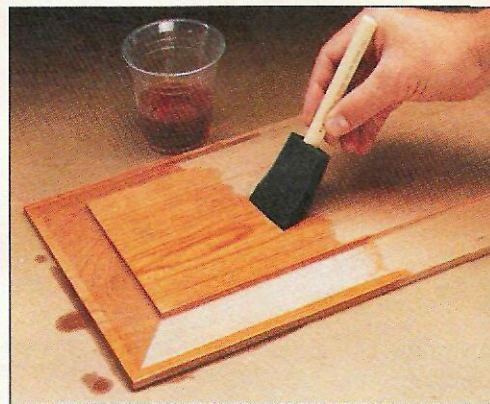
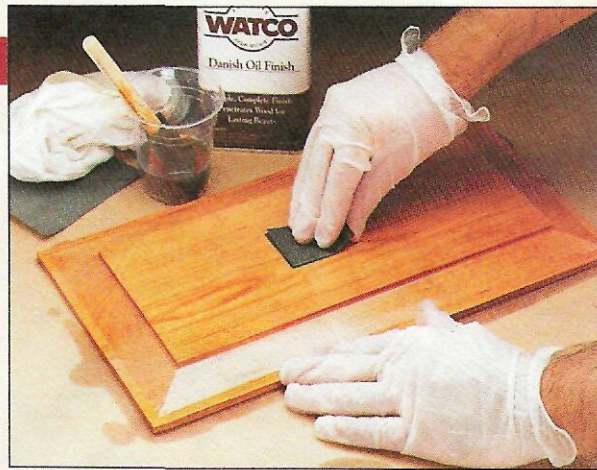

**A. Flood Surface.** Using a foam brush, saturate the surface of the wood with oil. If dry spots appear, just wipe on more oil until the wood won't soak up any more.



**B. Remove Excess.** Now wipe off all the excess oil so the wood looks “dry.” When the oil cures, apply additional thin coats until you get the desired sheen.



## Scenes From the Shop



▲ *Perfectly straight, accurate cuts. That's what you get every time you use this Cutting Guide with either a circular saw or router. The guide is made up of two*

*sections. Lock them together to rip the full length of a sheet of plywood. Or use a single section when you only need to cut across the width of the sheet.*



▲ *You don't need an expensive shaper or molder to make professional looking moldings. Instead, just use our simple technique to build them up a piece at a time.*

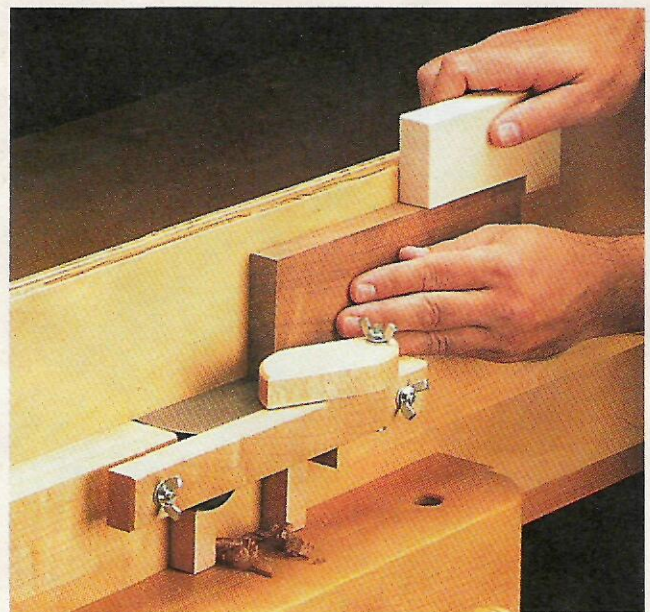

▲ *If you don't have a power jointer in your shop, or if you've ever felt uncomfortable jointing small workpieces, this Hand Plane Jointer is just the ticket.*



ShopNotes Issue 19  
 Centerfold — Cutting Guide  
 Exploded View

