

TIPS • TOOLS • TECHNIQUES

ShopNotes®

Vol. 4

Issue 21



ROUTER THICKNESSING JIG

- Adjustable Featherboard
- Table Saw Review
- Avoiding Kickback
- Tongue & Groove Joinery



ShopNotes

Issue 21

May 1995

EDITOR Donald B. Peschke
EXECUTIVE EDITOR Douglas L. Hicks
MANAGING EDITOR Richard S. Peters
ASSOCIATE EDITORS Tim Robertson
 Phil Totten
CONTRIBUTING EDITOR Mark A. Williams

CREATIVE DIRECTOR Ted Kralicek
ART DIRECTOR Cary Christensen
SENIOR ILLUSTRATOR Kurt Schultz
ILLUSTRATORS Roger Reiland
 Mark Higdon
PHOTOGRAPHER Crayola England
ELECTRONIC GRAPHICS Chris Glowacki

DESIGN DIRECTOR Ken Munkel
SENIOR DESIGNER Kent Welsh
SHOP MANAGER Steve Curtis
SHOP ASST./FACILITIES Steve Johnson

CIRCULATION

New Bus. Mgr.: Sandy Baum • *Dir. Mail Mgr.:* Troy Dowell, *Asst.:* Julie Greenlee • *Newsstand Sales:* Kent A. Buckton • *Analyst:* Shane S. Francis

CORPORATE SERVICES

Plan. Dir.: Jon Macarthy • *Controllor:* Robin Hutchinson • *Account.:* Laura Thomas • *Bkpr.:* Holly Lucas • *Prod. Mgr.:* Carol Quijano • *Pub. Serv. Mgr.:* Gordon C. Gaippe • *Artist:* Cheryl L. Cynor • *Info. Serv. Mgr.:* Joyce Moore • *Elect. Pub. Coord.:* Douglas M. Lidster • *Net. Adm.:* Nick Thielen • *Admin. Assists.:* Cheryl Scott, Julia Fish • *Recpt.:* Jeanne Johnson • *Bldg. Maint.:* Ken Griffith

PROJECT SUPPLIES

Art Dir.: Cindy Jackson • *Catalog Products Mgr.:* Bob Baker • *Inv. Control/Prod. Mgr.:* Mark Mattussi • *Proj. Supplies:* Linda Jones • *Tech. Support:* David Stone • *Sys. Oper.:* Tammy Aldini • *Ship. Supr.:* Nancy Johnson • *Fulfillment:* Gloria Sheehan, Chuck Carlson, Sylvia Carey, Larry Prine

CUSTOMER SERVICE

Mgr.: Jennie Enos • *Team Leader:* Karla Cronin • *Customer Service Reps.:* Jennifer Murphy, Joy Krause, Sara Kono, Anna Cox, Lonnie Algreen, Adam Best, Kristi Andrews



COMPUTER BULLETIN BOARD FOR WOODWORKERS

- Project plans and photos to download
- Woodworking HelpLine
- Indexes for Woodsmith & ShopNotes
- First month FREE for PC or MAC

To log on to WoodNet, call 1-515-245-9663. If you have any questions, please give us a call: (voice) 1-515-282-7000 M-F 9-5 CST.

ShopNotes® (ISSN 1062-9696) is published bimonthly (Jan., March, May, July, Sept., Nov.) by Woodsmith Corporation, 2200 Grand Ave., Des Moines, IA 50312. ShopNotes® is a registered trademark of Woodsmith Corp. ©Copyright 1995 by Woodsmith Corporation. All rights reserved.

Subscriptions: Single Copy, \$4.95. One year subscription (6 issues), \$19.95. Two years (12 issues), \$35.95. Canada/Foreign, add \$5.00 per year.

Second Class Postage Paid at Des Moines, IA and at additional offices.

Postmaster: Send change of address to ShopNotes, Box 11204, Des Moines, IA 50340-1204

Subscription Questions? Call 1-800-333-5854, 8am to 5pm, Central Time, weekdays.

E-Mail. Prodigy: EDJE97A, CompuServe: 75330,2301, Internet: 75330.2301@compuserve.com, America Online: Shopnotes.

PRINTED IN U.S.A.

EDITOR'S NOTE

Cutoffs

The blink of an eye. That's all it takes for an accident to happen in the workshop. And unfortunately, safety is one topic that just doesn't get much advance thought.

Sure, most woodworkers wear some type of safety glasses. And often use a push stick. But that just isn't enough. It has to be a part of everything you do.

The problem is that safety is one of those things you usually don't do anything about until something happens (often with disastrous results). And if you wait for an accident to happen before you become serious about safety, you could find your entire life changed.

INNER VOICE. That's what happened to Richard Suabedissen, a reader from Middlesex, New Jersey. He wrote to me about the *Cutoffs* in issue 17 where I talked about an inner voice that often "speaks" to woodworkers about safety.

In it, I suggested that the secret to safety is listening to this voice every time you hear it. Richard didn't. And with the hope that he could prevent an accident like his from happening to

someone else, he offered his letter for publication, see the box below.

I must admit, I was deeply affected by Richard's letter. After writing and thanking him for sharing his story, I felt compelled to do something about safety.

SAFETY. In this issue, you'll find two articles that can make your shop a safer place to work. The first article gives a number of ideas to help prevent kickback — one of the most dangerous things that can occur in the shop.

The second is a set of plans for an adjustable featherboard. Not only does it make work on your table saw or router table safer, it also adds precision to every cut or joint you make.

SAFETY FIRST. One final thought. The letter Richard sent spurred us into making our shop a safer place to work. I hope his letter gets you thinking about safety in your shop too.

A Kickback Incident

Dear Don,

I've been using my table saw for over 45 years for all types of wood-working and therefore am "experienced." Late one day, I was in a hurry to rip a 2x4 in half to make 1 1/2" x 1 1/2" x 9"-long garden stakes.

I meant to rip a long length first and then cut the pieces to size. But with my mind on a later phase of the project, I cut them to length first.

An "inner voice" told me that it wouldn't be too wise to rip these short pieces. But I was in a hurry and ignored it. After all, I've done this a thousand times before.

So I proceeded to rip a 9" piece. As I finished the cut, I pushed the outside (waste) piece away from the blade with my left hand.

A split second later, the blade kicked back the waste piece. Half of my left thumb was on the floor, and I was holding my totally severed left index finger in my left hand.

After thirteen grueling hours of microsurgery, the surgeons gave up trying to save the thumb. There was no chance at all for the index finger.

Please emphasize in your column again the need to "listen to the inner voice **every** time you hear it."

I didn't listen. And it took that piece of wood (traveling at over 100 feet per second), only .004 of a second to tear off my fingers and change the rest of my life.

Sincerely,
Richard H. Suabedissen

Contents

Projects & Techniques

Avoiding Kickback _____ **4**

Safety is no accident. Here's a close-up look at some of the causes of kickback and what you can do to prevent it.

Featherboard _____ **6**

A unique design lets you adjust this shop-made featherboard to use on many of the tools in your shop.

Tongue & Groove _____ **8**

Cutting a tight-fitting tongue and groove joint is easy when you follow our simple step-by-step approach.

Lap Desk _____ **11**

This compact lap desk provides space inside to organize pencils and paper and a large stable surface to write on.

Thickening Jig _____ **16**

You don't need a planer to thickness stock accurately. All it takes is a hand-held router and this easy to build jig.

Departments

The Small Shop Power Tools _____ **14**

Which power tools are best for the small shop? Full-size, benchtop, or combination tools?

Great Tips Glue-Up Tips _____ **20**

A collection of our best tips that includes everything from choosing the right glue to the best way to apply it.

Selecting Tools Table Saws _____ **22**

Our team tests six popular table saws and offers practical suggestions on selecting a saw that will suit your needs.

Readers' Tips Shop Solutions _____ **28**

Shop-tested solutions from our readers on their most common woodworking problems. Plus two quick tips.

Lumberyard Softwood Grades _____ **30**

Building a project out of softwood? Understanding the different lumber grades can affect its cost and appearance.

Finish Room Water-Based Top Coats _____ **31**

A durable finish that's easy to use. And no messy cleanup. All this makes water-based top coats worth a close look.



Featherboard page 6



Tongue & Groove page 8



Thickening Jig page 16

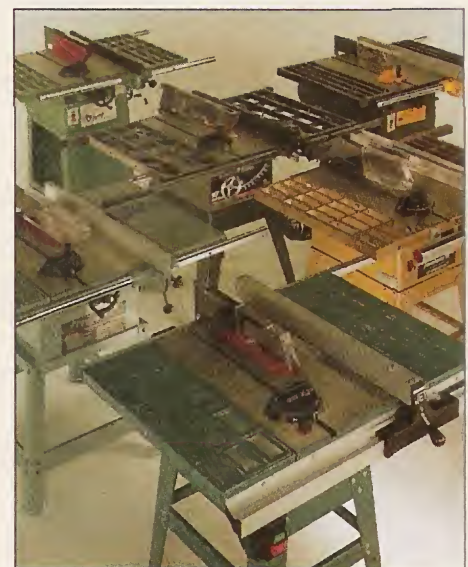
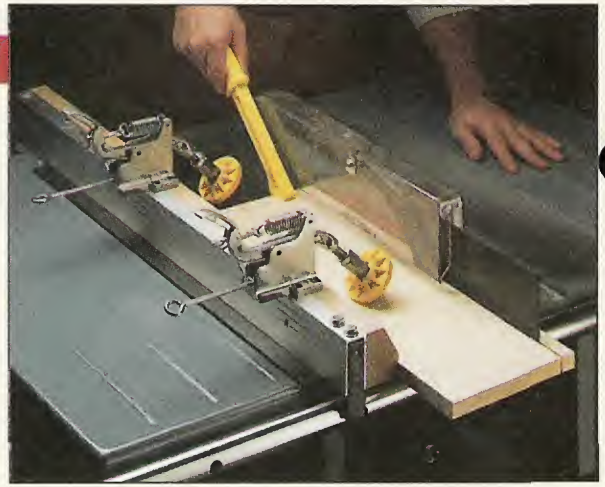

Table Saws page 22

Avoiding Kickback



I have a friend who has a piece of wood embedded in the wall behind his table saw. It's a reminder to others entering his shop not to stand directly behind the saw when it's in use. And it's a reminder to himself as to how dangerous kickback can be.

Kickback shouldn't be taken lightly. It's as serious as an unguarded saw blade or an exposed router bit. And the secret to preventing kickback (and an injury) is to understand where it's most likely to occur and what causes it.

TWO TOOLS. There are two tools in the shop where the potential for kickback is high: the table saw and router table (or shaper).

With the table saw, kickback is often the result of a workpiece

getting pinched between the blade and fence. Or the saw kerf closing up around the blade. In either case, the blade grabs the workpiece and propels it backwards — quicker than you can blink an eye, see Cutoffs, page 2.

But kickback on the router table occurs for a different set of reasons. For more on this, see the box on the opposite page.

FENCE POSITION. On the table saw, one of the simplest ways to get a straight, bind-free cut is to set the rip fence parallel to the saw blade. Having the fence parallel to the blade allows the workpiece to slide smoothly past the blade without binding.

To make sure the fence is *parallel* to the blade, I simply meas-

ure between the fence and one of the miter gauge slots — at both ends of the fence, see Fig. 1. (This assumes your saw blade is parallel to the miter gauge slot.)

Along with a properly set fence, there are a number of inexpensive things you can do to reduce your chances of kickback.

PAWLS. One thing you should *always* do is use your blade guard with its anti-kickback pawls, see photo above. As long as the pawls are sharp and well-maintained, they should dig in and “catch” the workpiece if it's kicked back.

SPECIAL INSERT. When I can't use the blade guard, I often use a special insert with a built-in splitter, see box below left. This splitter prevents the saw kerf from closing

Splitter Insert

There are times when I have to remove my blade guard for a certain cut. When this occurs, I replace the metal insert with a special insert that has a built-in splitter, see drawing.

The splitter helps protect me from kickback caused by a workpiece closing up around the saw blade — even with the blade guard removed.

The insert is just a scrap piece of hardwood cut and sanded to match the metal insert. A kerf in one end accepts a hardwood splitter that keeps the workpiece from pinching the blade.

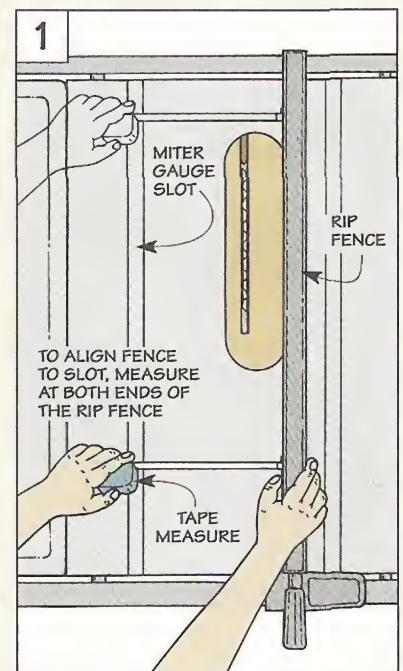
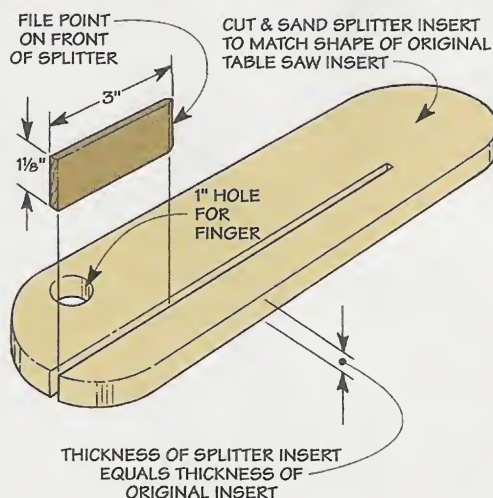

up around the saw blade.

Another way to help prevent kickback on the table saw is to use a pair of anti-kickback rollers or a featherboard.

ROLLERS. Anti-kickback rollers mount to an auxiliary fence that's bolted or clamped to the rip fence, see photo at left.

The unique thing about these rollers is they rotate only in *one* direction. And as a side benefit, the rollers hold the workpiece tight against the fence and table top to ensure a straight cut.

Rollers are available through many woodworking mail-order catalogs, see sources at right.

FEATHERBOARD. A featherboard works much like the anti-

kickback rollers. It also keeps a workpiece tight against the fence or table top to help you get a straight cut, see Fig. 2. And the fingers help prevent a workpiece from kicking back at you should the blade get a hold of it.

A featherboard, like the one shown here, is available through many woodworking mail-order catalogs, see sources at right. Or you can make your own, see page 6.

SAFETY TIPS. Whenever possible, it's also a good idea to use a push stick. It won't prevent kickback, but it just might save a finger or two if something does go wrong.

And finally, never remove the waste piece until the power is off and the blade has come to a stop.

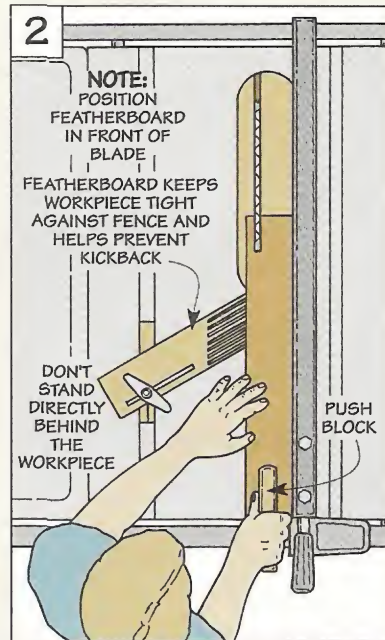

Router Table Kickback

Working with a router table can be deceptive. It might have a smaller motor and use a smaller cutter than a table saw, but a serious accident can occur here, too.

A workpiece can kick back if it's fed into a router bit too quickly. Or you try to remove too much wood in one pass. And even if the bit hits a knot. So it's a good idea to first carefully inspect the workpiece before turning on the router.

Also keep in mind the other rules for a router table. Rout in a right-to-left direction — whether you're using a fence or a bit with a bearing, see drawing. Never backrout — this is very dangerous.

With backrouting, there's always a chance the router bit will grab the workpiece and pull it, along with your fingers, into the sharp cutters.

Never rout with the workpiece *between* the bit and the fence. And always keep your fingers safely out of the way.

ANTI-KICKBACK BITS. You can also reduce your chances of getting kickback by using anti-kick-

back bits, see photo at right.

Unlike standard router bits, these bits have less cutter surface exposed, see detail A below. As the workpiece passes through the cutter, less wood can be removed per revolution of the bit. Less wood, less chance of kickback.

MULTIPLE PASSES. And one of the simplest ways you can reduce kickback is to nibble away at the wood by taking a series of shallow passes, see detail B below.



Anti-kickback Bits. A bit with less cutter surface exposed lessens the likelihood of kickback.

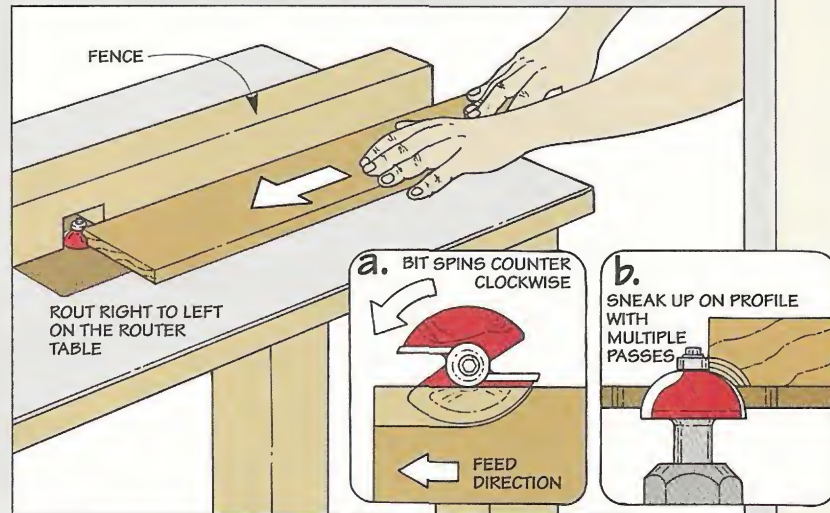

Sources

Anti-kickback Rollers & Featherboard

Garrett Wade
800-221-2942

Hartville Tool
800-345-2396

WoodsmithShop
800-444-7002

Woodworker's Supply
800-645-9292

Anti-kickback Bits

CMT Tools
800-531-5559

Leichtung
800-321-6840

Woodworker's Supply
800-645-9292

Featherboard

for your power tools

OVERALL DIMENSIONS:
4½" H x 34" L x 2½" D

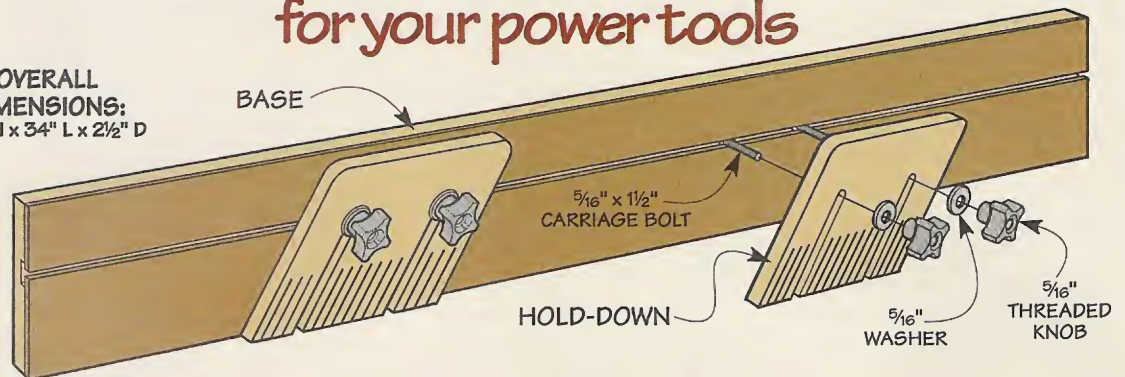

One of the simplest things you can do to make a table saw or router table safer for yourself is to use a featherboard.

A featherboard can help you hold a workpiece firmly against the table top or fence. It can also prevent a workpiece from kicking back at you if the blade or bit happens to grab hold of it.

Unlike most other featherboards, this one has two identical, adjustable hold-downs. Each hold-down attaches to the base by way of a pair of carriage bolts that fit in a T-slot in the base, see drawing above.

By loosening two knobs, each hold-down can be positioned anywhere along the length of the T-

slot or the height of the base. **Safety Note:** When cutting a deep kerf or all the way through, don't use the second hold-down as it can pinch the kerf closed.

BASE. The base of the featherboard is just a piece of ¾" plywood with a piece of ¼"-thick Masonite glued to one side, see Fig. 1. But before gluing the Ma-

Rip Fence. Clamping the featherboard to the table saw rip fence will press a workpiece firmly against the table top.

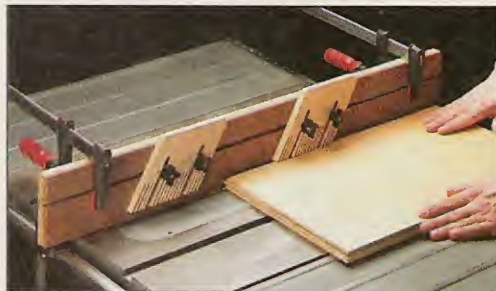
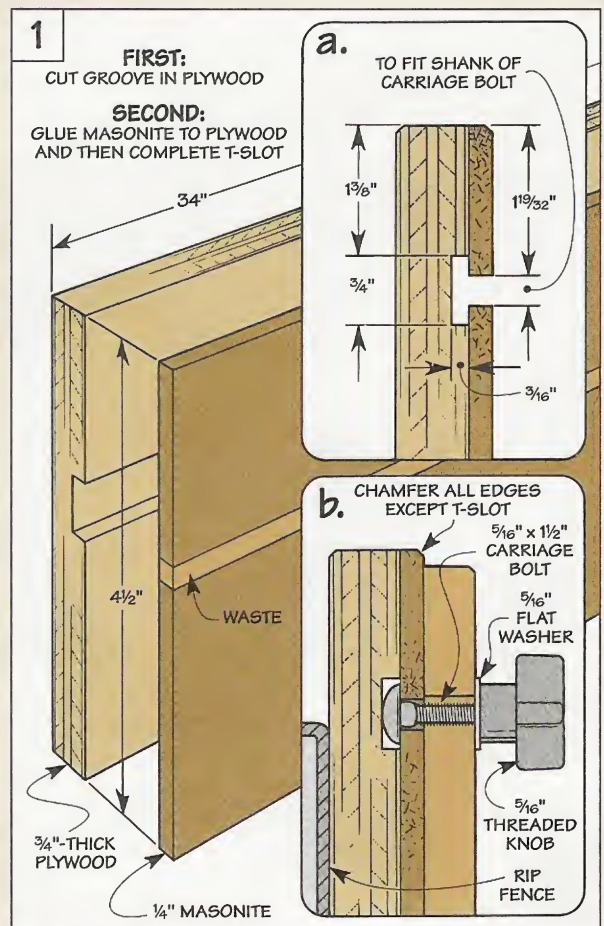
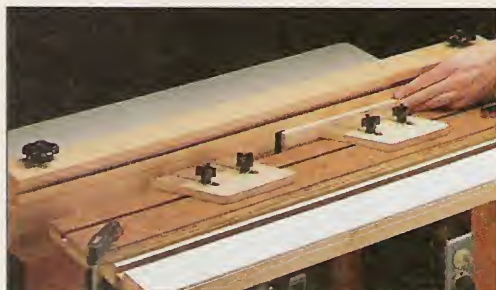

Table Top. Or you can clamp the featherboard to the table top to hold a workpiece firmly against the rip fence.



Router Table. Just like the table saw, you can clamp the featherboard to a router table top or a router table fence.



sonite in place, a groove is cut in the plywood to form the bottom half of the T-slot, see Fig. 1a. (I cut this groove to fit the head of a $\frac{5}{16}$ " carriage bolt.)

After the Masonite is glued in place (I used contact cement), the T-slot can be completed. To do this, cut a second groove centered directly over the first groove. You want the width of the second groove to just fit the square shank of the carriage bolt.

HOLD-DOWNS. Now the base is ready for the two hold-downs. Since these are going to take a lot of abuse, I made them from $\frac{1}{2}$ "-thick hard maple.

To make the hold-downs, first cut two blanks to finished width

and rough length, see drawing at right. Then so the hold-downs will grip a workpiece and prevent it from kicking back, cut the ends of each blank at a 30° angle.

To create the fingers which press against and grip the workpiece, the next step is to cut a series of kerfs. To do this so they'll be evenly spaced, I made an indexing jig that attaches to the table saw miter gauge, see box below.

Once the fingers have been cut, it's just a matter of laying out and drilling holes for the slots.

Then remove the waste with a band saw or sabre saw and attach the hold-downs to the base with the mounting hardware.

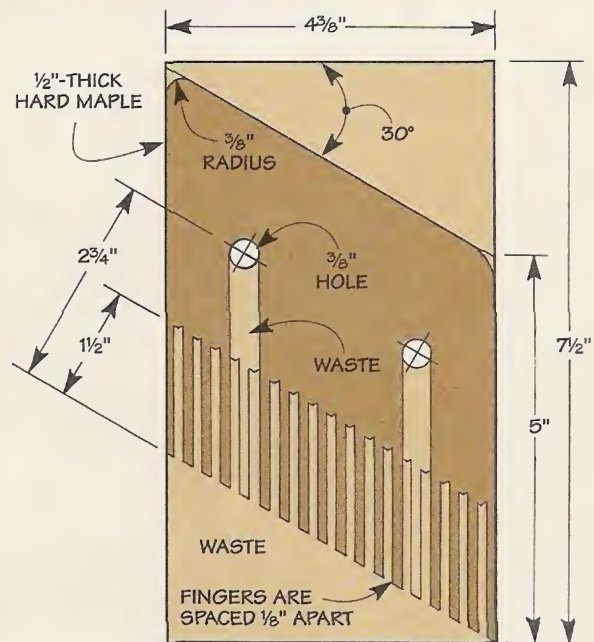

HOLD-DOWN

Indexing Jig

Cutting evenly-spaced kerfs on a featherboard hold-down is quick and easy with this indexing jig. If you're at all familiar with how a box joint jig works, then you're already familiar with how this particular jig works.

The jig has two saw kerfs that are spaced $\frac{1}{8}$ " apart, see drawing. One kerf has a hardwood pin glued in it. The other kerf lines up with the saw blade. Note: When screwing the jig to the miter

gauge, it's best to have the blade in this kerf so the jig is perfectly aligned with the blade.

To cut the first kerf, clamp the workpiece to the backing board so it's tight against the pin, see detail. Then make the first pass.

After the first kerf is cut, unclamp the workpiece and shift it over onto the index pin. Then re-clamp the workpiece and take another pass. Repeat this process to complete all the fingers.



Perfect Kerfs. The index pin makes it easy to cut evenly-spaced kerfs. Just index the workpiece on the pin between each pass.

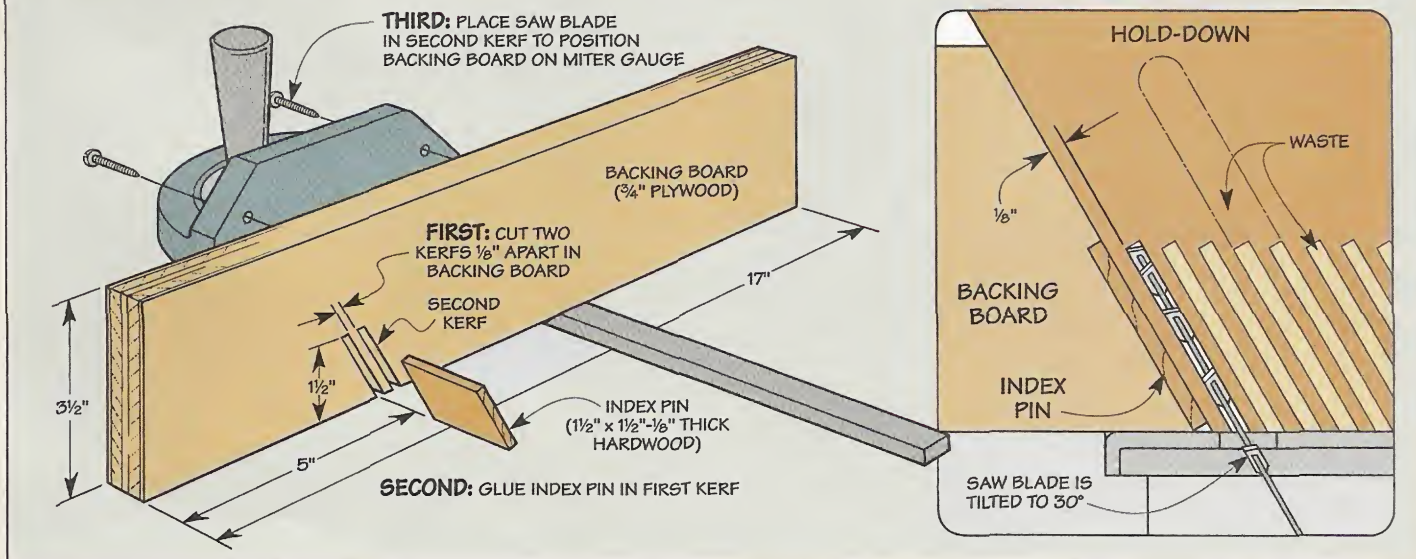

Tongue & Groove



Tongue. Forming a tongue is just a matter of routing a rabbet on each face. To ensure a consistent cut, a featherboard applies downward pressure.



Groove. A table saw makes quick work of cutting a groove to fit the tongue. Here, the featherboard presses the workpiece tight against the rip fence.

There's a good reason why so many hardwood floors are still as strong and flat today as the day they were laid down — they're held together with tongue and groove joints. Even though I don't install a lot of hardwood floors, I still find a tongue and groove joint useful on many of the projects I build.

ALIGNMENT. For example, when gluing hardwood edging to a plywood shelf, it automatically aligns the two pieces, see drawing A below. And it provides mechanical support as well as

additional glue surface.

STRENGTH. Even without glue, a tongue and groove joint offers plenty of mechanical strength. Take the back of a cabinet that's made up of a number of wood slats for instance. To keep the slats flush, tongue and groove joints form a strong, interlocking panel, see drawing B.

BREADBOARD ENDS. Another way to take advantage of this strength is to attach a "breadboard" end to a panel, see drawing C. Whether the panel is solid wood or plywood (like the top for

the lap desk on page 12), the breadboard ends help keep the panel from warping.

TWO TOOLS. While there are a number of different ways to cut a tongue and groove joint, I use a simple method that's as dependable as the morning paper.

All it takes is two tools: a router to cut the tongues, and a table saw for the grooves, see photos above. The nice thing about this method is it doesn't require a special router bit or saw blade. (I use a 1/2" straight bit and a combination saw blade.)

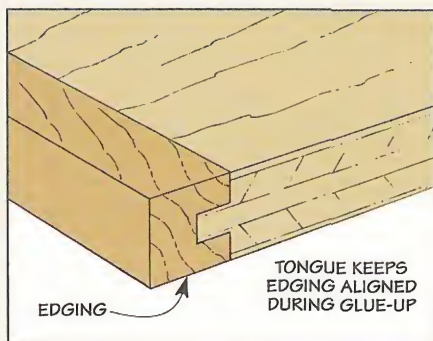

A. Alignment. A tongue and groove joint automatically aligns strips of hardwood edging on a plywood shelf.

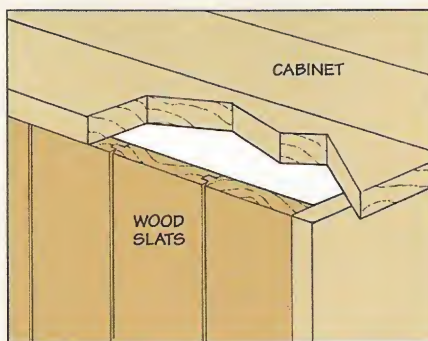

B. Strength. Even without glue, the strength of a tongue and groove joint keeps the slats on this cabinet flush.

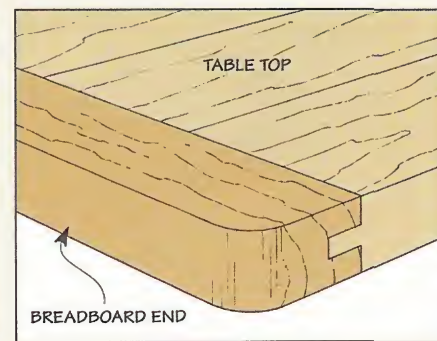

C. Flat. To ensure this table top stays flat, a "breadboard" end is attached with a tongue and groove joint.

The Tongue

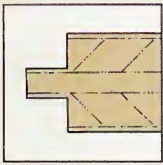

I usually start by cutting the tongue. Typically, it's centered on the edge of the workpiece by cutting two rabbets — one on each face.

In most cases, you can do this quickly and easily on a router table. But for large workpieces, a hand-held router works best, see the left-hand box below.

THICKNESS. Either way, you'll need to adjust the depth of cut to establish the thickness of the tongue. A simple rule of thumb is to make the tongue about one third the thickness of the workpiece.

LENGTH. Another consideration is the length of the tongue. This is determined by the position of the fence. The exact length isn't critical. I usually make the tongue so it's not more than twice as long as it is thick.

FEATHERBOARD. Before making a test cut to check the thick-

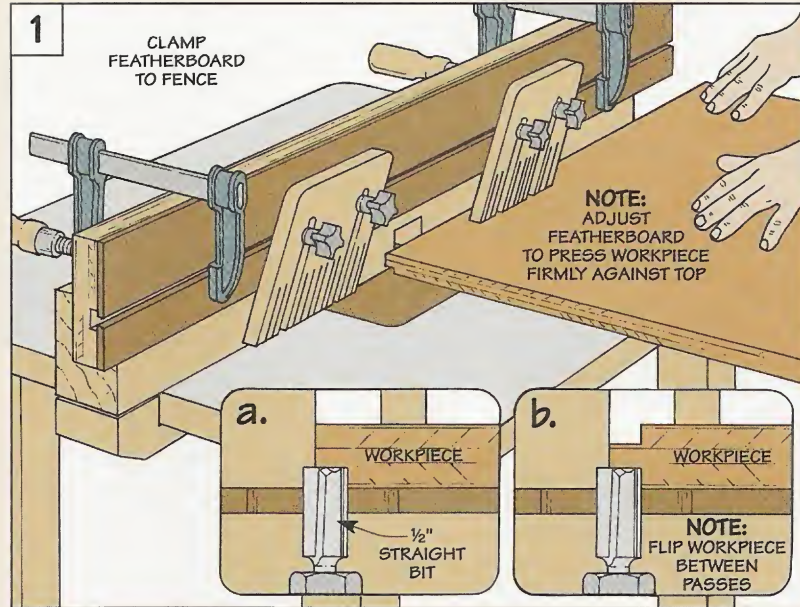

ness and length of the tongue, there's one more thing to do. To hold the workpiece down flat on the table and ensure the tongue is a consistent thickness, clamp a featherboard to the fence, see Fig. 1. (Plans for this featherboard are shown on page 6.)

TONGUE. Once you're satisfied with the setup, you can make the tongue on the "real" piece. Just rabbet one side of the workpiece, see Fig. 1a. Then flip it over and rabbet the opposite side, see Fig. 1b. Note: For a tip on making clean cuts, see right-hand box below.

Large Panels

When routing a tongue on a large panel, it's easier to use a hand-held router and a rabbet bit than to manhandle the workpiece on the router table.

Here again, the idea is to cut a rabbet on each face. But instead of a fence, the router is guided by a bearing on the bit that rides against the edge of the workpiece. By changing the size of the bearing (or bit), you can vary the length of the tongue.

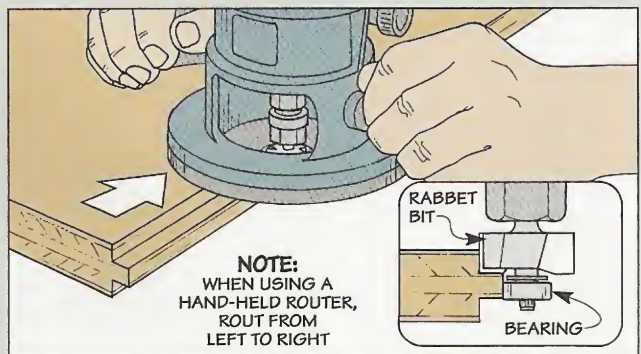

Clean Cuts

One problem I have when routing a rabbet in plywood (or cross-grain in hardwood) is I don't always get a clean cut. Scoring the shoulder of the rabbet with a knife helps, but it's hard to make this cut accurately.

To do this, I make a simple guide. It's just a scrap piece that's routed with an identical rabbet. This rabbet positions the edge of the scrap along the shoulder so you can score an accurate line on the workpiece.

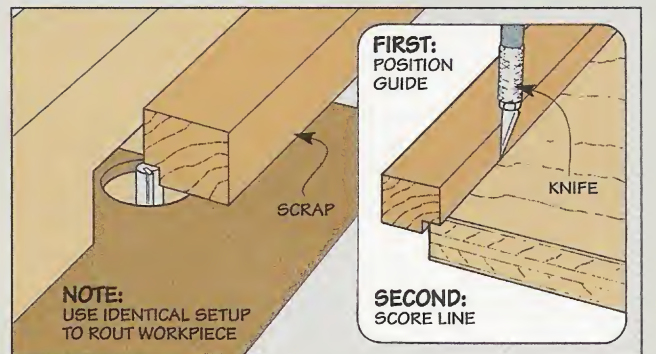

The Groove

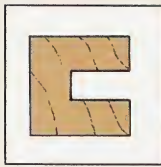

With the tongue complete, the groove can be cut to fit. In most cases, the groove is centered on

the edge of the workpiece.

While you'd expect this to make the surfaces flush, slight variations in thickness can expose one of the edges. So I use a workpiece that's slightly thicker (about $\frac{1}{32}$ "). This way, it will stand a bit "proud" when the pieces are assembled. And the surfaces can be sanded flush later.

DEPTH OF CUT. Before cutting the groove, you'll need to set the depth of cut. To allow room for excess glue, I adjust the blade height so the groove is about $\frac{1}{32}$ " deeper than the length of the tongue.

FENCE. Now it's just a matter of positioning the rip fence to locate the groove, see Fig. 2. To cut a groove that's centered *exactly* on the edge, I use a simple trick.

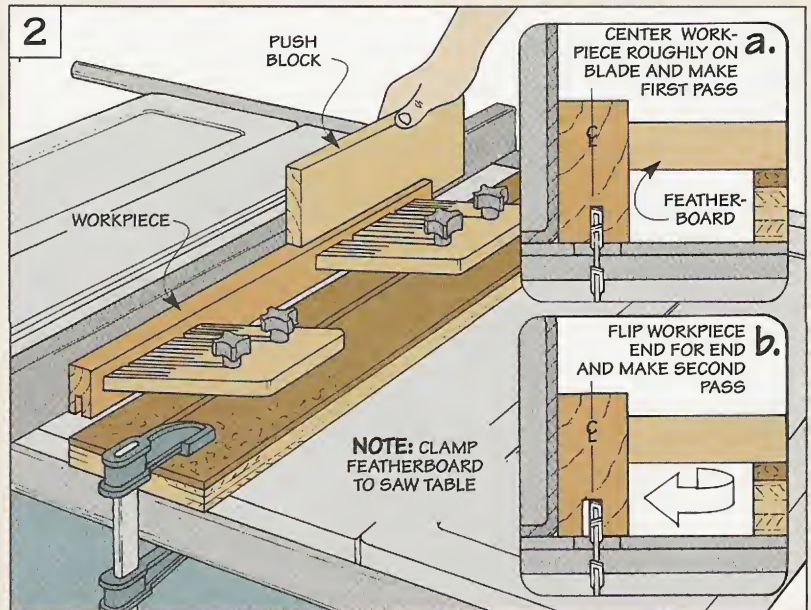

Start by roughly centering the edge of the workpiece on the blade and locking the fence. Now it's just a matter of making *two* passes. The first pass is made with one side against the fence, see Fig. 2a. Then flip the workpiece end for end and make a sec-

ond pass, see Fig. 2b.

TEST FIT. Although this produces a centered groove, it may not be wide enough to accept the tongue. So you may need to "bump" the fence a bit and make two more passes. Just continue like this until you get a perfect fit.

Assembly

There are several ways to assemble a tongue and groove joint.

PLYWOOD. The simplest way is when one of the pieces is plywood. To attach a hardwood strip (or breadboard end) to the plywood, just glue the pieces together.

SOLID WOOD. But when joining two solid wood pieces, you'll need to allow for movement caused by changes in humidity.

To do this, apply glue only to the middle third of the tongue, see Fig. 3. Then lock each end in

by "pinning" a small dowel through the tongue. (I glue an $\frac{1}{8}$ " dowel in a stopped hole.)

SAND FLUSH. Now just sand the surfaces flush. A sanding block gives good control to avoid cross-grain scratches, see Fig. 4.

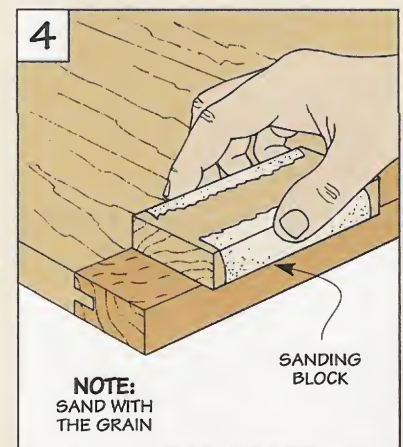
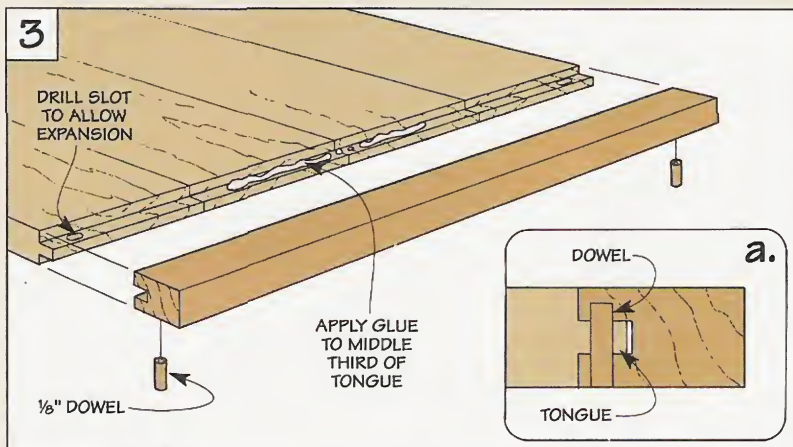



Lap Desk

This easy to build lap desk organizes pencils and paper and provides a sturdy writing surface as well.



Compact yet functional. That's what I like about this lap desk. A shallow tray organizes writing (or drawing) materials, see Exploded View below. And a top serves as a writing surface.

To provide access to paper and pencils, the top is hinged to the tray. And it's slanted — just

enough to make it comfortable to write on, but not so steep that paper slips around on the desk.

Finding the best writing angle was just a matter of experimenting a bit. But the real challenge was making the desk lightweight so it's easy to carry (even for a child). Yet sturdy enough to with-

stand getting knocked around.

The solution is to combine thin pieces of hardwood (I used $\frac{1}{4}$ " and $\frac{1}{2}$ "-thick maple) with $\frac{1}{4}$ "-thick plywood. While a single piece of plywood provides plenty of strength for the bottom, the top is built up from two layers to produce a stable writing surface.

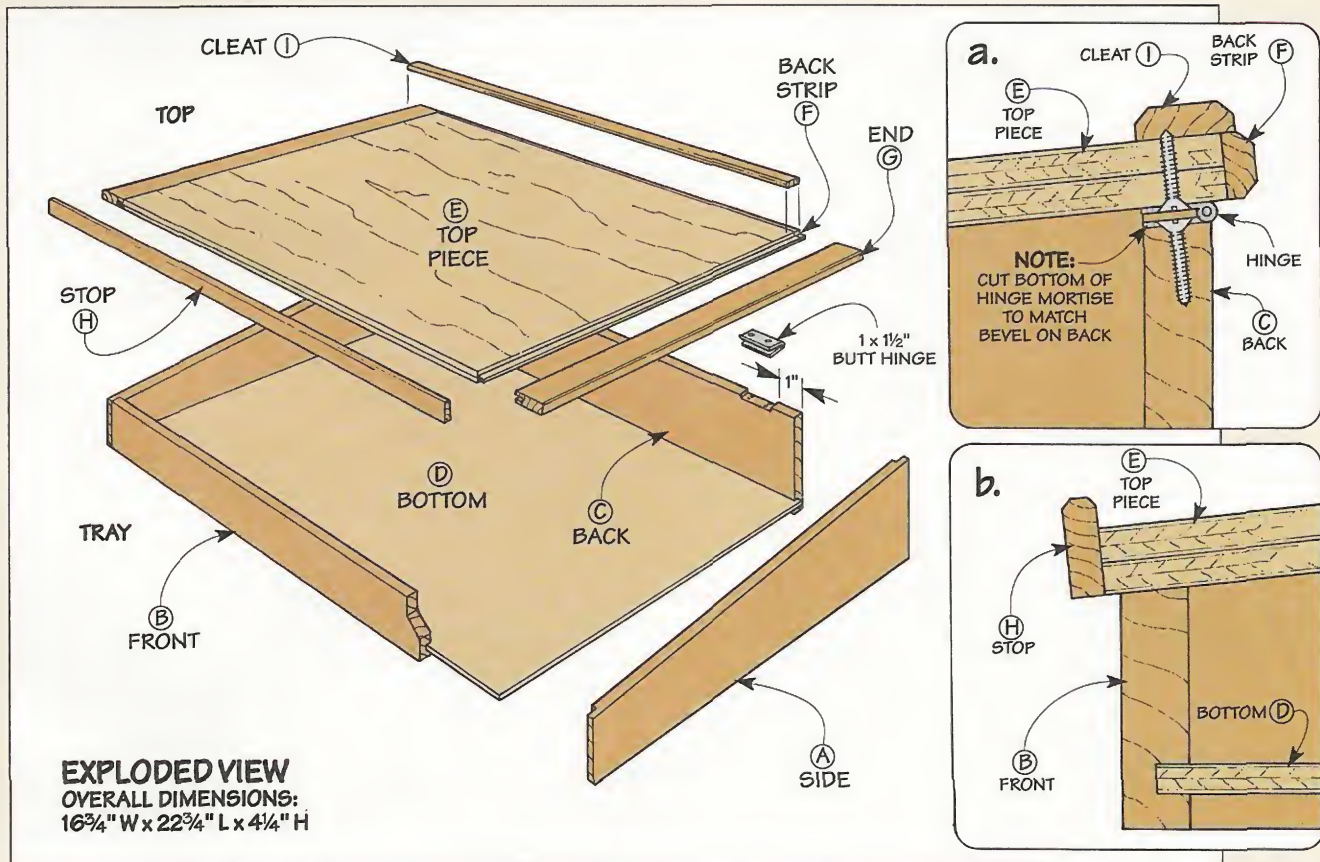

Tray

The tray is just a simple wood box that's used to store writing and drawing materials.

SIDES. To provide a comfortable writing position when the top is added, the *sides* (A) of the tray are angled, see Figs. 1 and 2. But before cutting the angles, it's easiest to rabbet both ends of the sides now to accept a front and back piece added later; see Fig. 1a.

Next, to make both sides identical, carpet-tape them together before cutting the shape with a sabre saw or band saw, see Fig. 2. Then shave off the remaining waste to the line with a hand plane.

FRONT/BACK. The sides are held together with a *front* (B) and *back* (C), see Fig. 1. To allow the lid to sit down tight, I beveled the top edge of each piece on the table saw to match the angle of the sides, see Fig. 1b.

The simplest way to do this is to dry assemble the tray and mark the bevel. Then rip a straight edge first so the pieces are $\frac{1}{8}$ " wider than finished size. Now rip the pieces to width as you cut the bevel.

BOTTOM. All that's left is to cut grooves in each of the tray pieces for a $\frac{1}{4}$ "-thick plywood *bottom* (D). After cutting the bottom to fit, just glue the tray together.

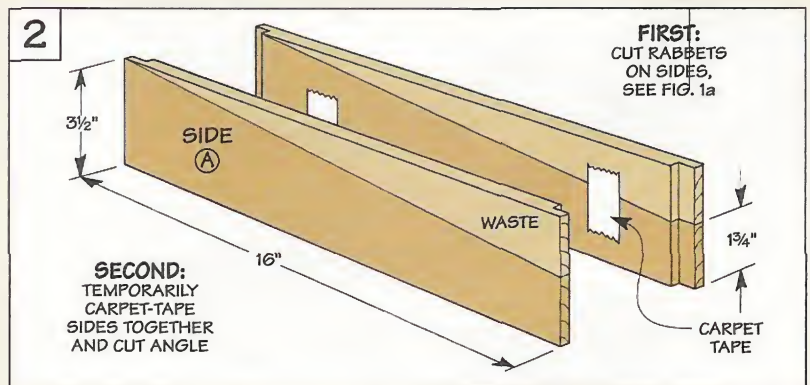
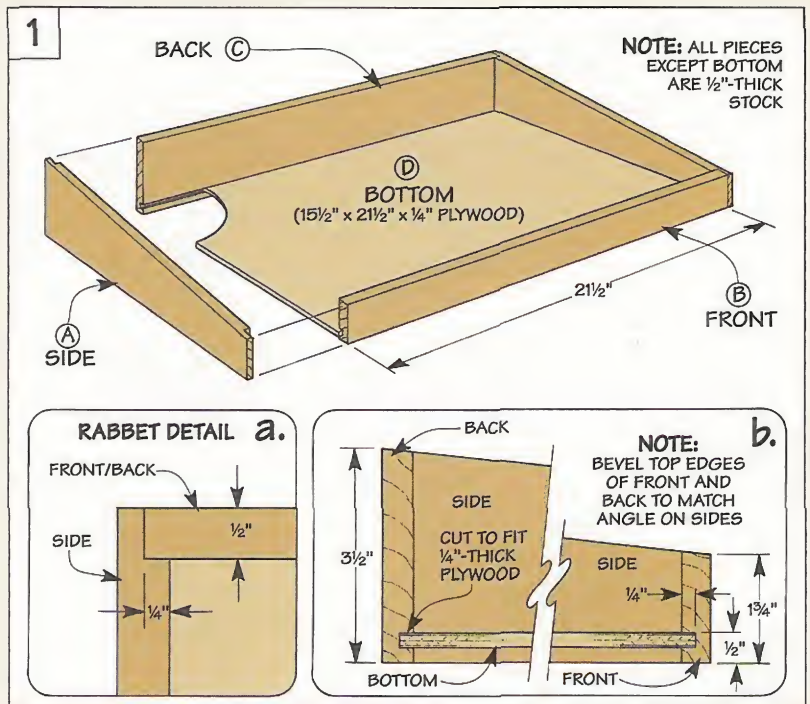

Top

With the tray complete, the next step is to add a top. What I wanted is a solid (yet light-weight) writing surface.

So I started off looking for $\frac{1}{2}$ "-thick maple plywood. But since that was hard to find, I decided to make my own out of two oversize *top pieces* (E) made of $\frac{1}{4}$ "-thick birch plywood, see Fig. 3.

These pieces are held together with contact cement (with the "good" faces out). Then simply square up the panel and trim it to final size, see box on next page.

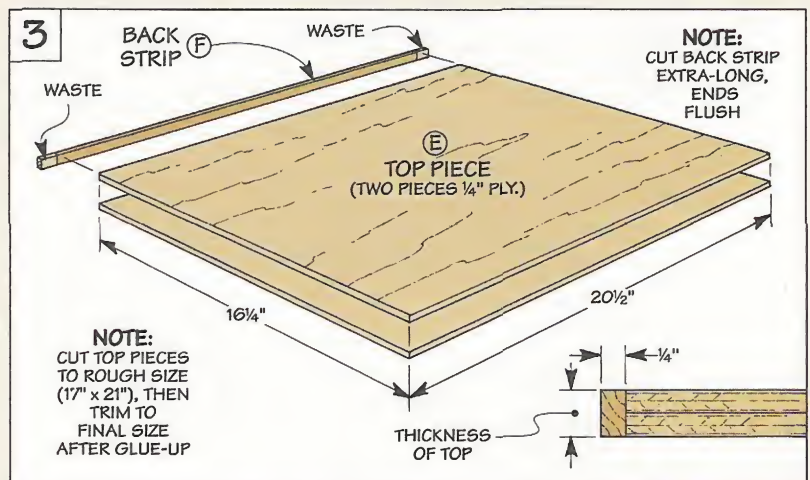

BACK STRIP. To cover the exposed edge on the back (the front edge is covered later), I added a hardwood *back strip* (F), see Fig. 3. It's a thin, narrow piece that's cut longer than the panel. After gluing it in place, just trim the ends flush.

BREADBOARD ENDS. Next, to make the top more rigid, I added two wide "breadboard" ends (G), see Fig. 4. These hardwood ends are held in place with a tongue and groove joint. (For more on this, see page 8.) After gluing the ends in place, I chamfered the top and bottom edges on the back and sides of the panel.

STOP. Now, to create a lip that keeps pencils from rolling off the desk, a *stop* (H) that's taller (wider) than the thickness of the top is glued on, see Fig. 5.

CLEAT. There's only one more strip — a *cleat* (I) for hinge screws that secure the top to the tray, see Detail 'a' in Exploded View on page 11. The hinges are screwed into mortises cut in the back (C) of the tray, see Exploded View.

Finally, I sanded chamfers on the stop and cleat and wiped on a couple coats of tung oil.

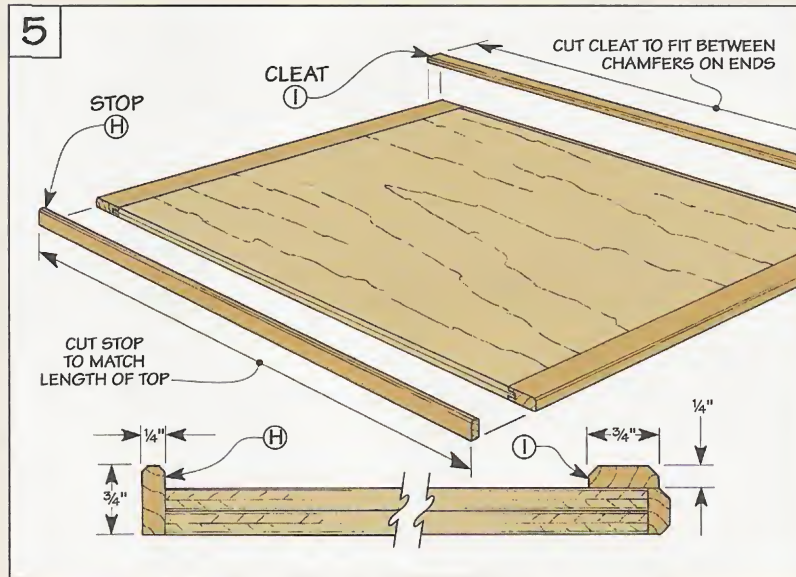
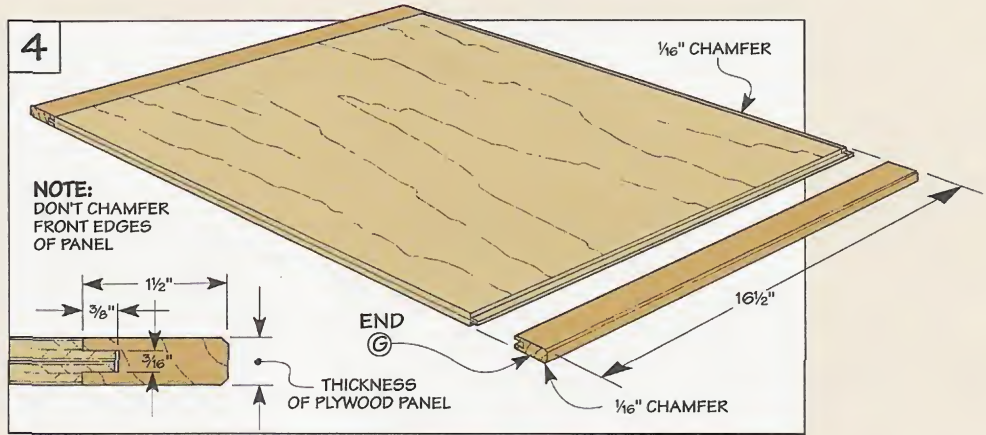

Squaring Up a Panel

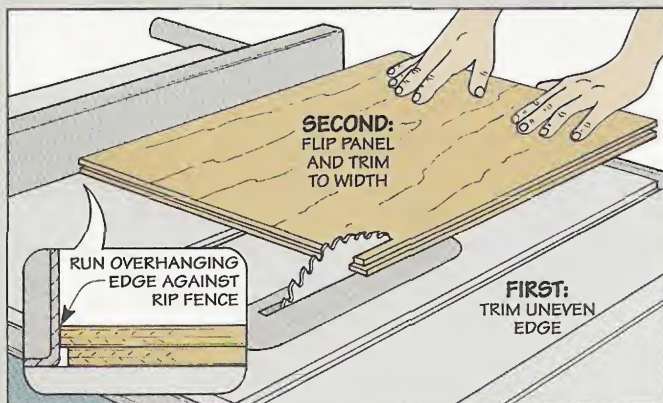

Edges. With an overhanging edge running against the rip fence, the first step is to trim the opposite edge straight. Then, after repositioning the fence, use the edge you just cut as a guide to trim the panel to final width.

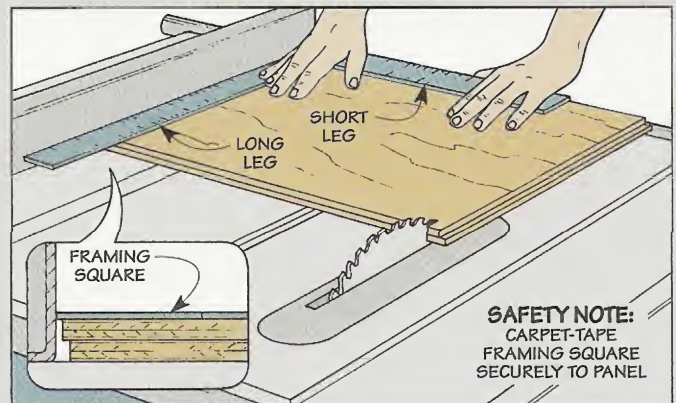

Ends. To trim the ends square, carpet-tape a framing square to the panel so the short leg is flush with the back edge and the long leg overhangs the end slightly. Once one end is squared up, remove the square and cut the opposite end.

Power Tools

for the small shop



Fitting a full complement of power tools into a small shop can be like packing a dozen sardines into a small tin. But it doesn't have to be that way. If the tools are selected and organized properly you can have the tools *and* still have room to work.

The key to selecting a power tool is to first determine how much use it'll get. If it's used a lot, go with a full-size stationary tool. If it'll only be used now and then, go with a bench-top tool that can be stored out of the way when not in use.

Shown here are the power tools I'd buy (in order) if I were outfitting a small shop today. Note: For those working in a really tight space, you might consider a multipurpose tool, see box on next page.

1. Table Saw. If I could only have one power tool in my shop, it would be a contractor's table saw (refer to the table saw review starting on page 24).

The table saw in our shop is used all the time to rip, crosscut, and miter workpieces. It's great for cutting rabbets and dadoes. And the large table top makes it easy and safe to cut a full-size sheet of plywood.

Note: From time to time you may need to move the saw around to make certain cuts. So it's a good idea to also invest in a set of castors or a mobile base.

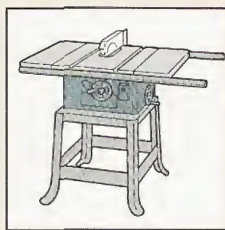

2. Dust Collector. When working in a small, enclosed shop, you should be concerned about protecting your lungs from sawdust. Since a table saw kicks up a lot of dust, your next purchase should be a two-stage dust collector to hook up to the saw.

Most small two-stage dust collectors come with a quick-disconnect hose that makes it easy for you to connect to other tools with the same mated connector. And many dust collectors also come with castors so you can easily roll it out of the way when it's not being used.

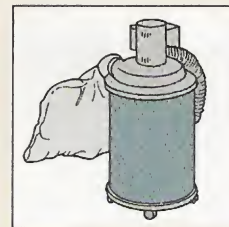

3. Router Table. I never realized how much of a necessity a router table was until I started using one. The router table in our shop gets used every day.

Not only is it used for routing decorative profiles, but it's also great for routing rabbets, dadoes, and box joints. And with special router bits, you can even rout raised panels.

Although in many cases a hand-held router could also get the job done, I'm more comfortable with the control the router table offers with its larger table top, adjustable fence, and miter gauge.

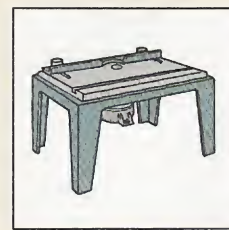

4. Drill Press. The next tool I'd buy would be a drill press. And there are a couple of ways to go here.

If you're only going to use a drill press for drilling holes, you might consider a small, bench-top model. When it's not in use, you'll be able to store it out of the way in a corner or down under a workbench.

But if you're going to drill a lot of holes, mortises, or use it for sanding, you might consider a larger, full-size model. It won't take up much more space, and you'll have a large table top and bigger motor to handle the extra work.

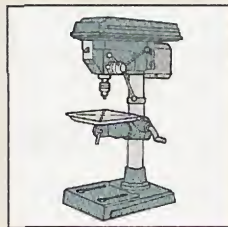

5. Thickness Planer. In the past few years, the cost of owning a thickness planer has dropped like a tackle box sinking in a lake.

For less than \$400, you can choose from a number of quality 10" and 12" bench-top thickness planers that should handle most of your planing needs.

A planer in the shop means you won't be limited to the lumber thicknesses available at your local lumberyard. And you can save money by buying rough stock directly from a sawmill and planing it to thickness yourself.

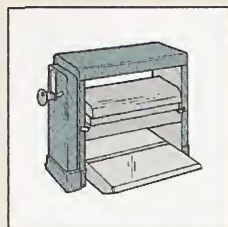

6. Compound Miter Saw. A radial arm saw is a great power tool for crosscutting and mitering. But they take up a lot of space. And they're not portable.

A compound-miter saw on the other hand is both portable *and* compact. Miter saws have been used primarily by trim and finish carpenters because of their portability and accuracy. But they're starting to find their way into many workshops — for the same reasons. Although smaller, you'll find that a compound-miter saw will cost about the same as a radial arm saw.

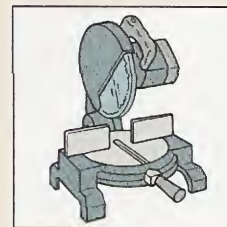

7. Band Saw. My final tool of choice for the small shop is the band saw. A band saw is great to have around if you're going to cut a lot of curves and circles. Or resaw lumber — which can save you money when you're working with thin stock.

Again, like the other power tools, determine how much use a band saw will get. If you think you'll use one a lot, go with a full-size model with a mobile base. If it's only going to be used occasionally, a bench-top model will work just fine, and it will cost a lot less than a full-size band saw.

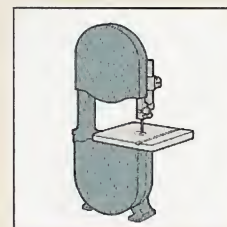

Multipurpose Tools

Another space-saving measure when you're working in a small shop is to select a power tool that does multiple jobs.

Many of these machines, like *Robland*, *TotalShop*, *Shopsmith*, and *Kity*, combine five tools into one, see photo at right.

They all provide a lot of wood-working in a small space. But setting up the different operations isn't as efficient as it can be with individual power tools.

Another small shop option that's worth considering is a combination tool, see far right photo. With this type of machine, you'll typically find a jointer combined with a planer. Or a disk sander combined with a belt sander.



▲ A multipurpose tool such as this Kity K-5 combines a table saw, edge jointer, thickness planer, shaper, and mortiser. It has many of the advantages that similar stationary tools have, but takes less space. (Farris Machinery: 800-872-5489)



▲ This Hitachi P12RA planer/jointer combines a 12" thickness planer with a 6" edge jointer. A combination tool like this takes up less space than two similar, separate bench-top power tools. (Hitachi Power Tools: 800-362-7297)

Router Thicknessing Jig



A new jig in our workshop will always draw some skeptics — and this thicknessing jig for the router was no exception. But all it took was a couple of passes of the router for everyone to realize that not only did it work — it worked better than we had hoped.

Sure, we expected the jig to quickly thickness a board. But we were really surprised at how smooth and flat the board was. So smooth that light sanding is all that's necessary — no planing,

scraping, or heavy belt sanding.

SPECIAL BIT. The secret to such a smooth finish is the special router bit we used. It's a 1"-dia. bottom-cleaning bit, see box on opposite page. Though the jig is designed for this bit, you could use a normal straight bit — you just won't end up with a surface that's quite as smooth.

THICK & THIN. The jig is also designed to thickness both thick and thin stock. It easily handles stock up to 1" thick. And with the workpiece shimmed up, stock can

be thickened down to 1/4", see photo A below.

WIDE PANELS. Another thing I like about this jig is it can be used to thickness glued-up panels and wide boards, see photo B.

FLATTEN STOCK. One last surprise is how effective the thicknessing jig is at flattening a cupped or warped workpiece, see photo C. Just create a flat on one side of the workpiece as a reference. Then flip the workpiece over and rout the board to the desired thickness.

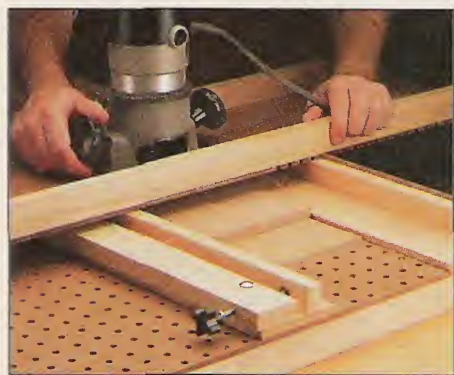

A. Thin Stock. You can thickness thin stock as well as thick stock by adding a shim under the workpiece.

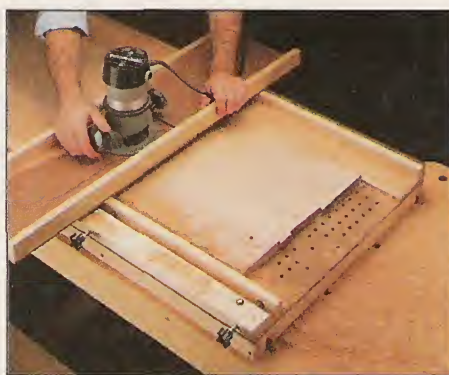

B. Wide Panels. The thicknessing jig can handle glued-up panels and wide boards up to 15 3/4" in width.

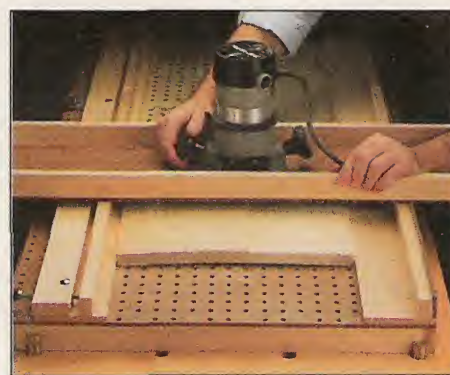

C. Flattening. In addition to smoothing stock, this jig can also flatten a cupped or warped workpiece.

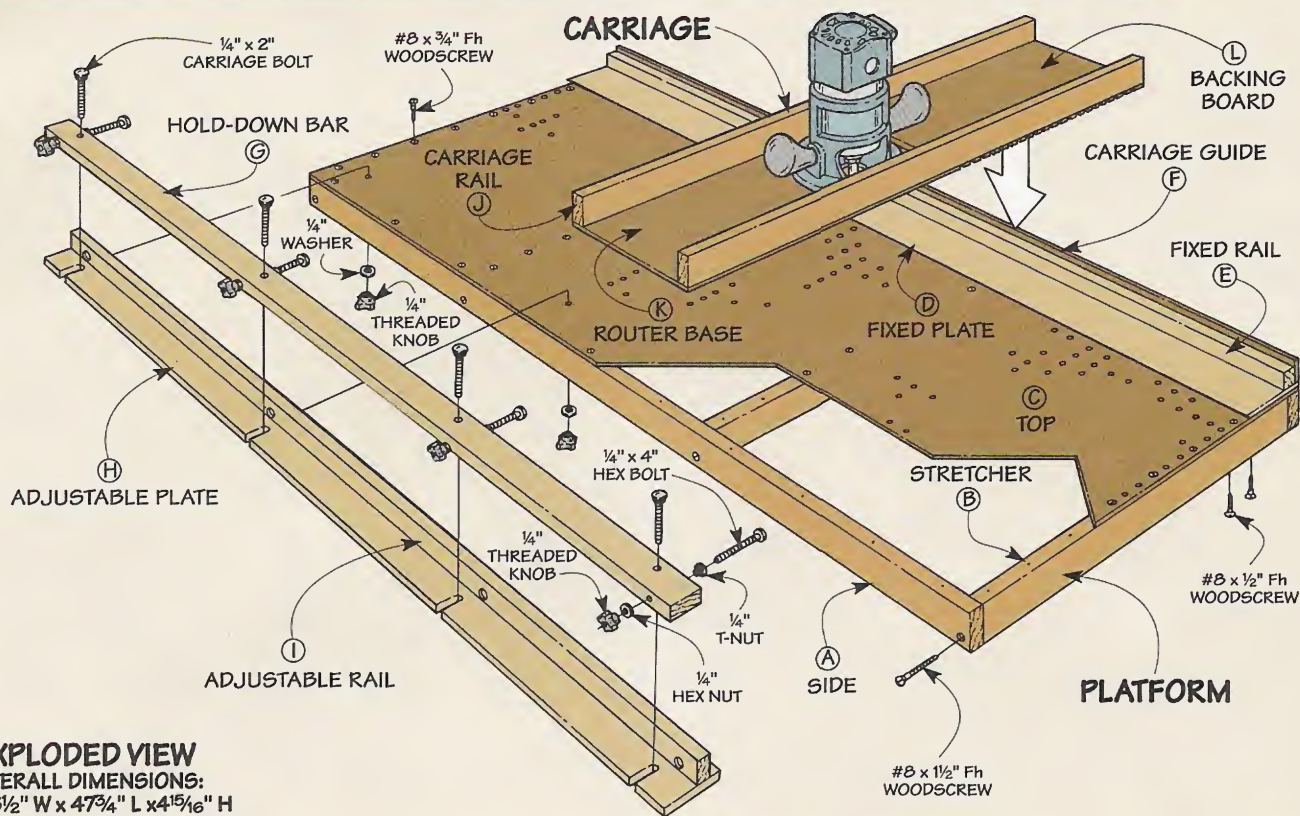

EXPLODED VIEW
OVERALL DIMENSIONS:
 36½" W x 47¾" L x 4¹⁵⁄₁₆" H

Hardware

- (8) ¼"-20 Threaded Knobs
- (4) ¼" x 4" Hex Bolts
- (4) ¼" x 2" Carriage Bolts
- (4) ¼" T-Nuts
- (4) ¼" Hex Nuts
- (4) ¼" Flat Washers
- (8) #8 x ½" Fh Woodscrews
- (70) #8 x ¾" Fh Woodscrews
- (8) #8 x ½" Fh Woodscrews

CROSS SECTION

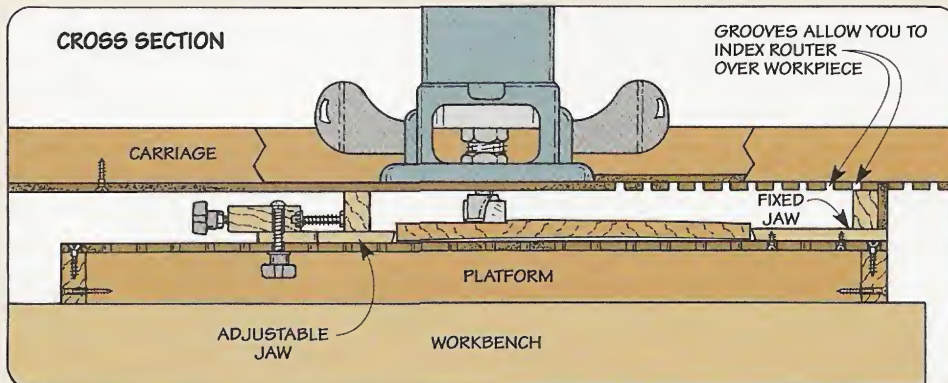

Materials

Platform

A Sides (2)	¾ x 1½ - 47¾
B Stretchers (4)	¾ x 1½ - 22¼
C Top (1)	23¾ x 47¾ - ¼ pegbrd.
D Fixed Plate (1)	¾ x 4 - 47¾
E Fixed Rail (1)	¾ x 1½ - 47¾
F Carriage Guide (1)	1⁵⁄₁₆ x 47¾ - ¼ Mas.
G Hold-Down Bar (1)	¾ x 2½ - 47¾
H Adjustable Plate (1)	¾ x 4 - 47¾
I Adjustable Rail (1)	¾ x 1½ - 47¾

Carriage

J Carriage Rails (2)	¾ x 1½ - 36½
K Router Base (1)	9 x 36½ - ¼ Mas.
L Backing Board (1)	7½ x 16¼ - ¼ Mas.

Bottom-Cleaning Bit

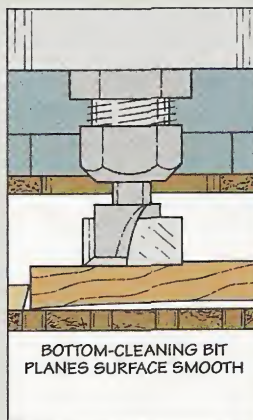

This bottom-cleaning bit is similar to a straight bit. But it has an additional set of cutters on the bottom that are designed to "plane" the surface smooth and flat. What you end up with is a surface that requires very little sanding.

The 1"-dia., ½" shank bit I use is available from Cascade Tools (800-235-0272). Ask for part C1259 (\$14, plus shipping).

Construction

The thickening jig consists of two main parts: a platform that holds the workpiece, and a carriage that supports the router, refer to Exploded View on page 17.

PLATFORM

The platform consists of a rectangular-shaped base with two jaws. One jaw is fixed; the other is adjustable, see Fig. 1.

BASE. The base is just a hardwood frame consisting of two sides (A) that are drilled and screwed to four stretchers (B). (I used hard maple.)

To make it easy to position the adjustable jaw anywhere on the base, I used 1/4" pegboard for the top (C). Shop Tip: Instead of drilling extra holes to screw the pegboard to the frame, cut the pegboard so the existing holes are centered over the frame pieces, see End View in Fig. 1.

FIXED JAW. The next step is to make the fixed jaw. It's made up of three parts: a plate, a rail, and a carriage guide, see Fig. 2.

The plate (D) is beveled so the jaw can grip a workpiece better. The rail (E) is screwed to the plate to form an L-shaped sup-

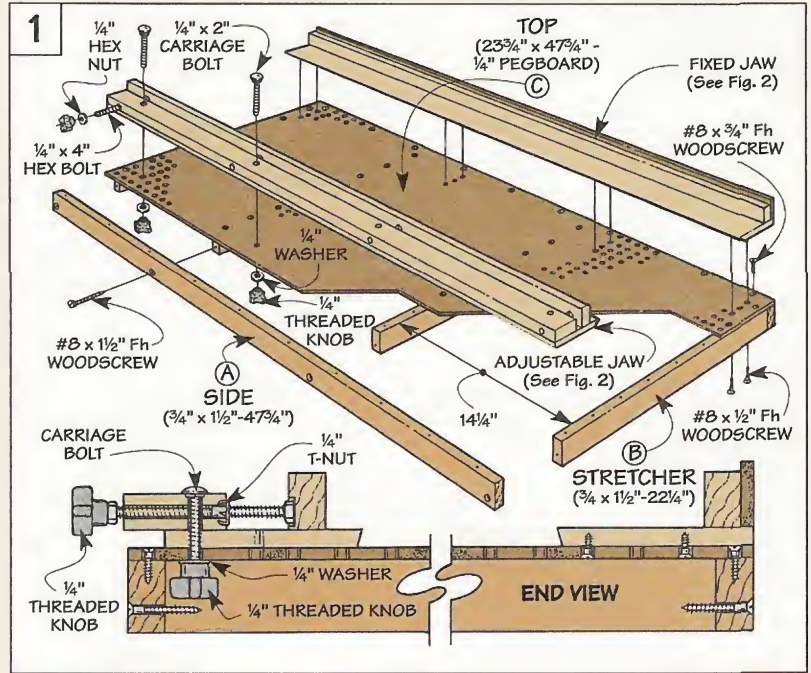

port for the carriage. And to guide the carriage, a carriage guide (F) made from 1/4" Masonite is glued to the rail (E).

After you've glued and screwed the jaw together, it can be mounted to the base, see Fig. 1.

ADJUSTABLE JAW. The adjustable jaw also has three parts. But each is a bit different. In order for the plate on the adjustable jaw to

move and press against the workpiece, it isn't screwed to the base. Instead, it's held in place with a hold-down bar, see Fig. 2.

The hold-down bar (G) sits on top of the plate (H). Bolts pass down through it (and slots in the plate) into the pegboard and plate securely to the base. Then, to allow the plate to be

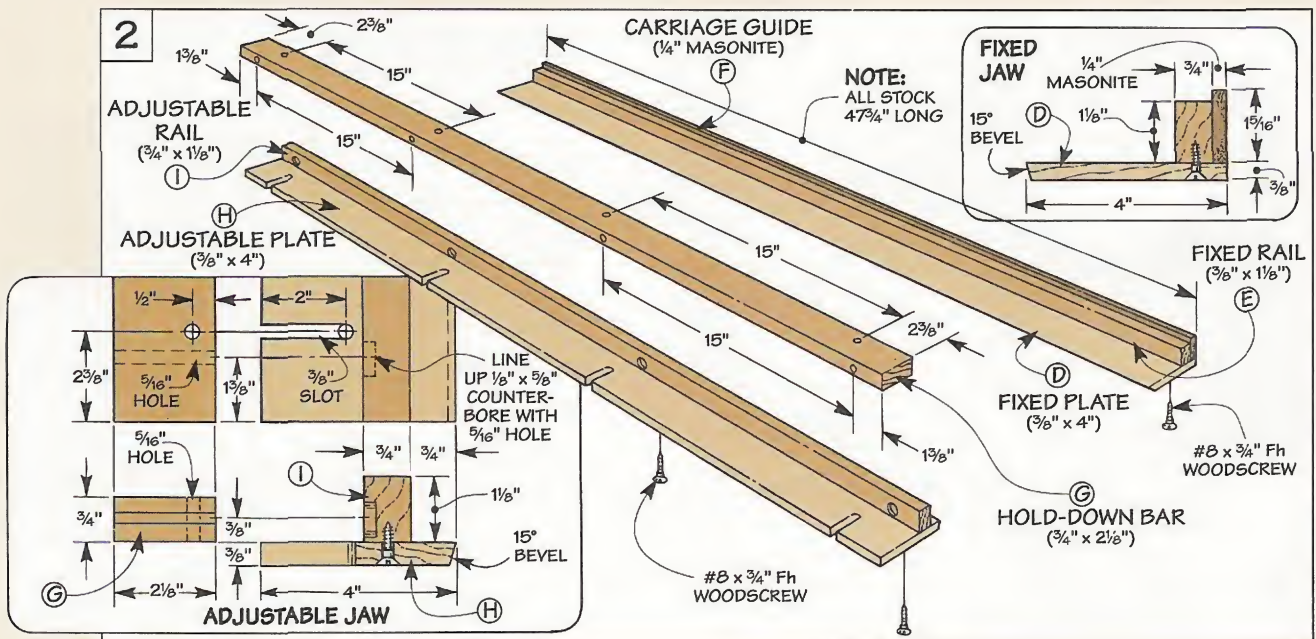

adjusted, a second set of longer bolts run through the width of the hold-down bar into T-nuts and press against the rail (I).

Counterbores in the rail accept the bolts and keep the jaw from sliding when pressure is applied. The clamping pressure comes from threaded knobs (or wing nuts) and jam nuts threaded onto each bolt.

Once the adjustable jaw is complete, attach it to the base, see Fig. 1 and Exploded View on page 17.

CARRIAGE

The carriage supports the router above the workpiece as it rides across the platform. It consists of a pair of rails with a base for the router. Grooves in the bottom allow you to "index" the router over the workpiece in even increments, see photo above right.

RAILS. I began work on the carriage by making the rails (J), see Fig. 3. They're both cut extra long so the carriage can reach the jaws no matter where it's indexed.

The rails are glued and screwed to a router base (K) made of 1/4" Masonite, see Fig. 3. Safety Note: Don't screw into the section of the base that will be grooved later on.

BACKING BOARD. To support the grooves that are cut next, a backing board (L) is cut to fit between the rails and is glued to the top of the base (K), see Fig. 3.

After the glue dries, the index grooves can be cut. These are just a series of 1/4" grooves on the bottom of the base (K) to fit the carriage guide (F), see Fig. 3a.

The grooves are spaced for the bottom-cleaning bit, see page 17. This provides a 1/4" overlap on each pass. Note: If you're using a



▲ Grooves in the bottom of the carriage fit over the carriage guide on the platform to produce overlapping passes.

different bit, you may need to space the grooves differently.

MOUNT ROUTER. After you've cut the grooves, cut a hole for the router and mount it to the carriage.

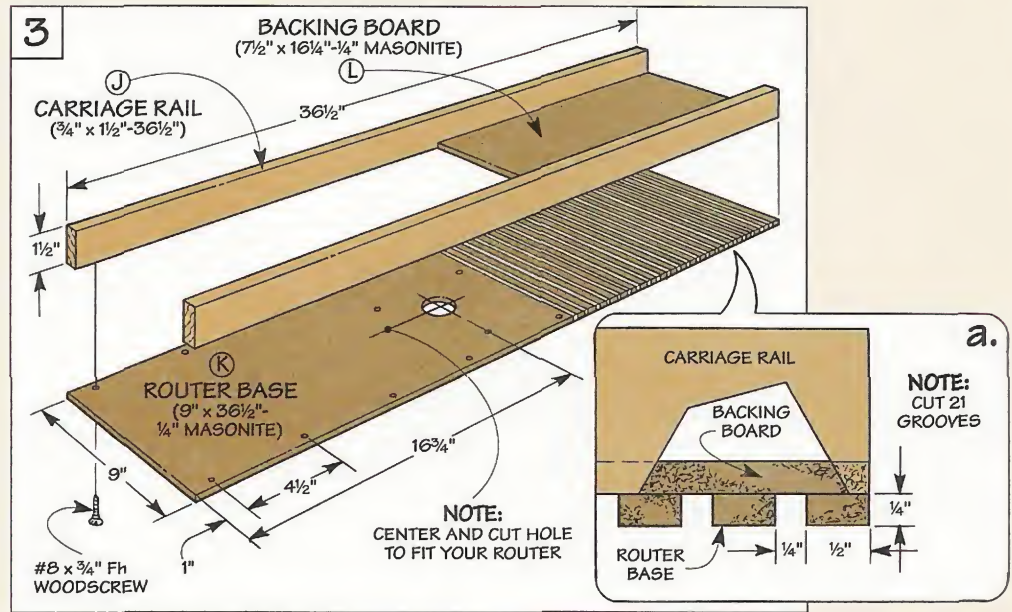

Using the Jig

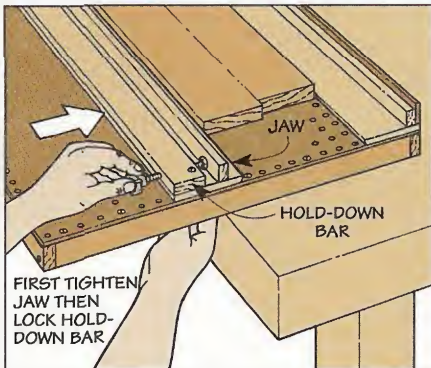

Setup. To secure a workpiece in the jig, first position the adjustable jaw. Then tighten the hex bolts to move the jaw as you lock the hold-down bar.

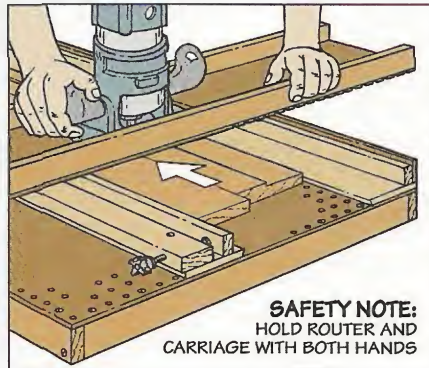

Thickness. Place carriage on platform and rout in a left-to-right direction. Pull carriage back to clean up pass. Then index router and repeat.

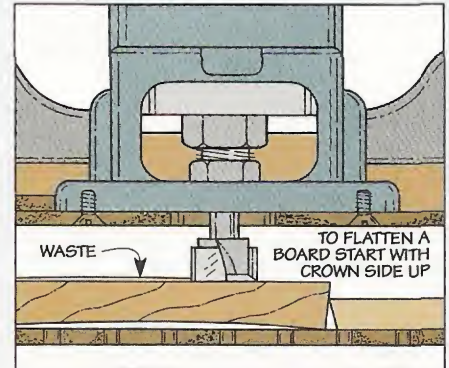

Flatten. To flatten a workpiece, start with the crown side up. Once you've "leveled" the crown, flip it over and thickness the other side.

Glue-Up Tips

There's more to applying glue than squeezing it out of a bottle. Here are a few tips to make the job go easier.



Glue & Storage



White Glue. Use white glue instead of yellow glue to provide more assembly time when working with a complex project.

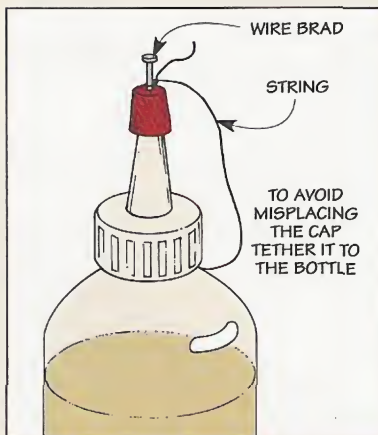

Tether Cap. To avoid misplacing the tiny cap on the end of a glue bottle, tether it to the bottle with a wire brad and a piece of string.



Glue Bottle. A clean, empty mustard bottle makes a great glue bottle. It's free, airtight, and has a handy twist cap.

Applicators

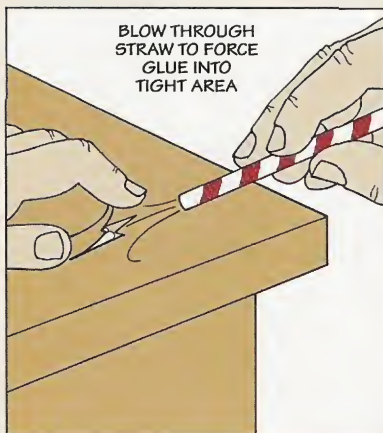

Forcing Glue. Getting glue into a tight spot can be a problem. To solve this, blow through a straw to force the glue in place.



Glue Spreader. An old toothbrush is the best tool I've found for spreading glue. It spreads it evenly and cleans up easily.



Glue Roller. To quickly and evenly spread glue out over a large surface, I use a small, short-napped paint roller.

Squeeze Out

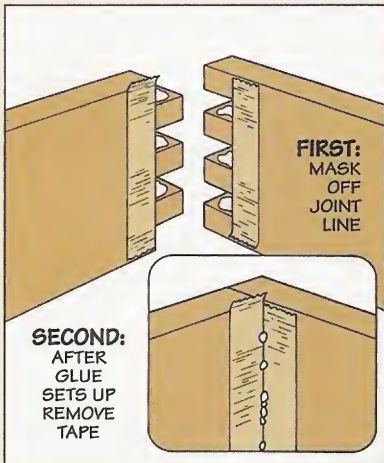

Mask Corners. Taping off inside corners before gluing and assembly reduces the time spent later cleaning out the corner.

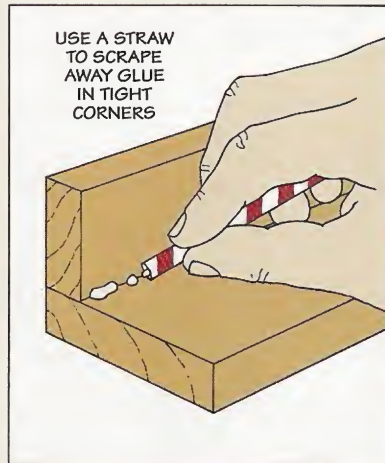

Glue Scooper. A straw works great for scooping away skinned-over beads of glue that are trapped in tight corners.



Glue Scraper. Use a plastic clip from a bread bag to scrape away skinned-over beads of glue from a flat surface.

Contact Cement

There's really no great mystery in working with contact cement. All you basically have to do is apply an even coat on the two surfaces that are going to be joined. Let the glue dry until it's skimmed over and dry to the touch (about 20 minutes depending on the humidity). And then place one piece on top of the other.

Application of most brands of cement is about the same. But to be sure, always read the instructions on your particular brand before you begin.

Also, make sure you work in a well ventilated area since many brands of contact cement contain solvents that can cause respiratory problems.



Trowel. The key to a good bond when working with contact cement is to spread the cement evenly. To do this, I use a small, hand-size piece of plastic laminate as a trowel.



Non-Stick Barrier. Waxed paper between workpieces gives you a chance to make last minute adjustments. Once the pieces are aligned, pull out the paper and apply pressure.



Emergency Release. In the event of a disaster, you can separate the two workpieces by flowing a liberal amount of lacquer thinner between them and gently peeling off one of the layers.

Table Saws



◀ Our team of testers includes three people. Ken (left) is a professional carpenter and cabinetmaker while Steve (center) spends most of his time building projects for his house and shop. Cary (right) is just setting up his shop.

There's one thing I've noticed about most woodworking shops — a table saw usually occupies center stage. Not just its physical location. But the fact that a table saw is at the heart of almost every project built.

That's why selecting a table saw is such an important decision. After all, it's a big investment in money. And a good quality saw provides the groundwork for making straight, accurate cuts and tight-fitting joints.

To make this decision easier,

we bought six table saws, see photos below. Then we asked three woodworkers with different interests and skill levels to test them. This way, you can identify with one of these people based on the type of work *you* do — and choose the saw that's best for you.

To ensure reliable results, we bought identical carbide-tipped blades for each saw. Then we had the same person (Steve) assemble and tune up all the saws.

Q: *First impressions count. For example, what did you think of*

the way the saws were packaged?

Steve: The Delta and Jet were packaged the most securely — like somebody cared that everything got here in good condition. Much better than having loose parts rattling around in the box like the Grizzly and AMT saws.

Q: *Did you find any damaged or missing parts?*

Steve: The worst damage I found was on the AMT. The shaft that controls the angle of the blade was bent. And the threaded end was “filed” down by a cast iron extension wing that rubbed against it in shipment.

As far as missing parts, both AMT and Jet forgot to pack a miter gauge along with the rest of



AMT
Model 4572
\$445



Delta
Model 34-444
\$599



Grizzly
Model G1022
\$375

SELECTING TOOLS

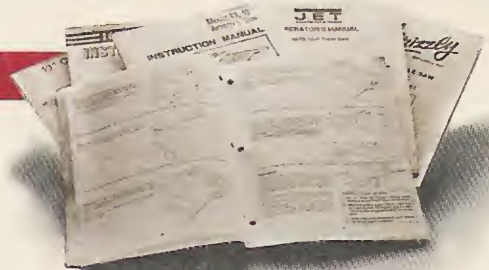

the saw. And the belt and pulley guard was missing from the Jet. Fortunately, customer service was helpful, and it only derailed me a few days.

Q: *That gave you some extra time to look over the manuals. Were some more helpful than others?*

Steve: Some manuals (like the Jet and Delta) were like having a good road map — clear illustrations and easy-to-follow directions. But using the AMT manual required a lot of guesswork — especially when wiring the motor.

Even a manual that was as thick as a book didn't make it any easier to assemble the Sears saw. (See photo above.) In fact, it took me twice as long as the other saws.

One thing I appreciated is the straightforward approach in the Grizzly manual. It makes no bones about the fact you might be short a piece of hardware (as it turned out, I wasn't) or that you may have to file the sharp edges and burrs (plan on doing some filing).

Q: *What about the metal stands on the saws?*

Steve: What sticks in my mind is the Jet stand is held together with forty bolts. And each bolt has a lock washer to keep the nut

from vibrating loose. Maybe that's why it's so sturdy.

But with the heaviest gauge metal of all of the stands, the Delta is also rock solid. (See photo below.) At first, I thought the closed panels on the Grizzly and AMT stands might compensate for their thinner gauge metal. But these stands wiggled even after I'd assembled the saws.

Q: *One thing I noticed is the blade guard on the Grizzly is different than the rest? Is different better?*

Steve: Don't count on it. The Grizzly guard has two metal arms that move independently. Be-

▲ Manuals. *In spite of a 72-page manual, the Sears saw is much more complicated to assemble than the other saws.*

sides the fact that adjusting the linkages on these arms is like wrestling an octopus, they block my sight of the blade.

The plastic guards on the other saws are easier to see through. And with the exception of the Delta, they stay up out of the way when I'm changing blades.

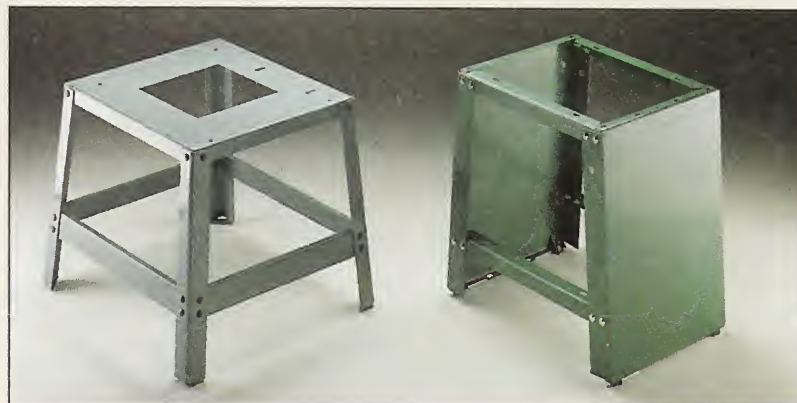

▲ Stands. *Heavy-gauge metal and a wide stance create a stable base for the Delta saw (left). But the Grizzly stand (right) tends to wobble, even with solid panels on the front and back.*



Jet
Model TWTS 10JF
\$579



Powermatic
Model 63 \$679



Sears
Model 29886
\$499

Saw Table

Q: Each saw has a heavy, cast iron table. Besides weight, what do the tables have going for them?

Cary: One thing is the bevel on the front edge of the Jet and Delta saw tables. (See photo at right.) At first, I couldn't figure out why it was there.

But when I used the miter gauge to crosscut a wide panel, the reason hit home. Instead of clunking against the edge of the saw table, the miter gauge rides smoothly over the bevel.

Q: Did you check out the flatness of the table top?

Ken: That's not something that drastically affects a cut. But a table that's absolutely flat does give me an idea of the overall quality of the saw. And I'm always using my saw table as a reference for establishing the flatness of a workpiece.

So I like the dead flat tables on the Jet and Sears saws. While there's a slight hump in the Delta table, the other tables are "dished" in the middle. (See the right-hand photo above.)

Steve: Also, the grinding on the Jet and Delta tables was smoother than the other saws. Especially compared to the AMT and Grizzly that were gouged around the opening for the insert.



Bevel. The miter gauge slides smoothly over the beveled edge on the Jet and Delta saw tables.



Flatness. Dollar bills slipped under a straightedge reveal a "dish" in the Grizzly saw table.

Q: Speaking of inserts, what were you looking for?

Steve: One that's sturdy and won't flex — like the heavy-gauge Delta and Jet inserts. These inserts also had more ribbing for support than the AMT, Grizzly, or Powermatic inserts. (See margin photos.)

Cary: Another thing about both the Delta and Jet inserts is there's a finger hole that makes it easy to lift them out when I change blades. The AMT and Grizzly inserts don't have finger holes. And they fit so tight I had to poke a stick up through the back of the saw to pop them out.

Ken: My pet peeve is an insert that rattles when you turn on the saw. The AMT and Powermatic solve that problem with spring clips that press against the sides of the saw table around the opening. And there's no vibration with the Sears insert either since it's

screwed in place. But it drives me nuts getting a screwdriver out every time I change blades.

Cary: Something that bugged me when I changed blades on the Jet saw is the opening for the insert is 1/4" narrower than the other saws. So I had to scrunch up my hand to thread on the arbor nut — especially when I put on a full width dado blade.

Q: One thing we haven't talked about is the extension wings that bolt to the saw tables.

Steve: Originally, I was leaning toward the cast iron extension wings on the Sears, Grizzly, AMT, and Powermatic saws. (See photos below.) After all, the more mass the better when it comes to dampening vibration.

But when I pinched my finger in one of the openings as I was sliding the rip fence, I started believing in the stamped steel wings on the Delta and Jet saws.

Delta



AMT



Sears



Extension Wings. Heavy-gauge stamped steel extension wings on the Delta and Jet saws (left)



provide plenty of support when crosscutting a long board. And unlike the open-grid cast iron

wings on this Sears saw (right), there are no sharp edges to accidentally "catch" your fingers.

Miter Gauge



Slots. A straight slot like on the Sears and AMT saws (left) makes it easy to insert the bar on the miter gauge. But it doesn't lock the miter gauge in the slot like the T-shaped slot on the other saws (right).

Q: At a glance, all the miter gauges look a lot alike. So what separates one from another?

Steve: One thing I noticed was the bars on the Sears and AMT miter gauges fit in a U-shaped slot. (See photos above.) That's okay if I'm crosscutting a workpiece that doesn't hang over the edge of the table. But with a large workpiece, the T-shaped slot on the other saws is a big help.

That's because there's a special washer attached to the end of the bar that locks the miter gauge in the T-slot — even when I pull it all the way back. As a result, I don't have to worry about supporting the miter gauge *and* the workpiece at the same time.

Cary: I think the T-slots are a hassle. Every time I use the miter gauge, I have to slide the bar into the slot from either the front or back of the saw. So I'd just take off the washer.

Q: Regardless of the shape, what did you notice about the fit of the bar in the slot?

Ken: I was impressed by the fit of the bar on the Grizzly miter gauge — like a well-machined tool. Although there's some "play" in the bars on the Jet and Delta miter gauges, they're better than the loose fit of the Sears and Powermatic.

Cary: At first, I thought AMT had a great idea with its miter gauge — to make it adjustable.

But when I adjusted the bar to remove all the play, it stuck in the middle of the cut.

What this boils down to is the width of the slot varies from one end to the other. And even worse, when I switch from one slot to the other, the miter gauge won't even fit unless I readjust the bar. So there's no consistency from one slot to the other either.

Q: What about the adjustments for the preset stops at 45° and 90°?

Steve: Except for the Sears, all the miter gauges use a metal tab as a stop. (See right-hand margin.) But there's enough flex in the tabs on the Grizzly, AMT, and Powermatic that it's hard to return to the same setting over and over again. The sturdier tabs on the Jet and Delta produced a much more positive stop.

Ken: The Sears miter gauge has a different stop system — a pin that slips into a slot in the back of the miter gauge. It's a good, solid stop. But I can't adjust *one* stop without affecting *all* of them. And if I'm cutting miters for a frame where accuracy is critical, that's a real headache.

Cary: At least with the adjustment screws on the other miter gauges, I can change the stops independently. On the Delta, I just have to tweak an Allen screw. That's handier than fiddling with the adjustment screws and nuts on the other saws.

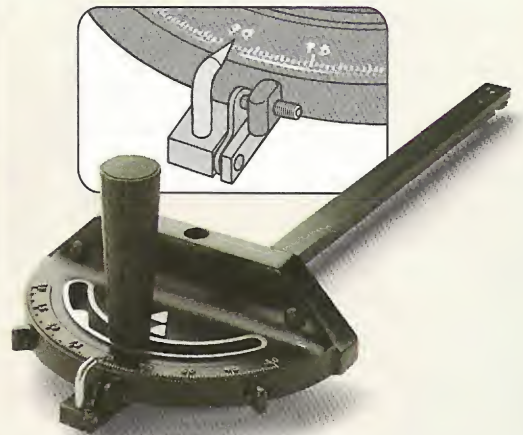

▲ Delta. A metal tab and an Allen screw make the 45° and 90° preset stops on the Delta miter gauge accurate and easy to adjust.

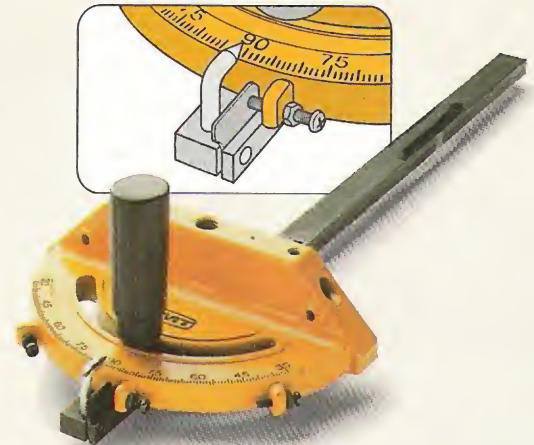

▲ AMT. Adjustment screws on the AMT miter gauge aren't as handy. And a flimsy metal stop makes it less accurate.

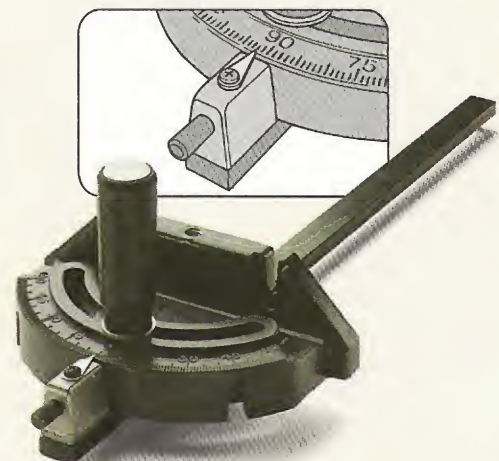

▲ Sears. A pin in the Sears miter gauge provides a positive stop. But the 45° and 90° stops can't be adjusted independently.

Rip Fence

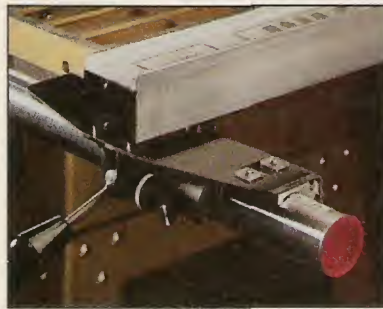

Guide Rails. Regardless of the shape, the rails that guide the rip fence should be rigid and strong. In addition to being the most solid guide rails, the aluminum channel on the Jet (left) and the round tube on the Powermatic (center) provided a smoother action than the angle rails on the Sears saw (right).

Q: The rip fence can make or break a saw. So how do the fences stack up against each other?

Cary: That's where I noticed a big difference. Starting with how smoothly the fences on the Jet and Powermatic glide across the guide rails. (See photos above.)

Although the fence on the Delta saw doesn't slide as easily, it's definitely a step above the AMT and Grizzly. Sliding these

fences across the rails sounds like you're dragging a piece of iron across concrete. And the Sears fence lurches like a beginner learning to drive a stick shift.

Steve: Even more important to me is whether the fence locks parallel to the blade. There's nothing more frustrating than having to measure the distance from the fence to the front and back of the blade every time I make a cut.

The only fences I found that locked parallel consistently are the Jet, Delta, and Powermatic. There's so much slop in the locking mechanism on the AMT and Grizzly fences, I can't rely on them. And it's like spitting in the wind trying to keep the Sears fence adjusted to lock parallel.

Q: What about the face of the fence? Is it square to

the saw table?

Ken: That's something I look at closely — especially since I resaw a lot of thick stock into thin boards. And I can't do it accurately if the fence isn't square to the table.

What I found is all the fences are flat and square except the Sears and Grizzly. Adjusting the guide rails is supposed to square up the Sears fence. But it's a chore. Especially compared to a simple, built-in adjustment on the Powermatic.

Q: How accurately can you position the rip fence?

Cary: I got spoiled by how easy it is to read the indicators on the Jet, Powermatic, and Sears fences. (See photos below.) The pointers on the other saws aren't quite as accurate. And on the AMT and Grizzly, I can't even see the numbers on the scale because they're hidden by the casting that holds the fence on the rail.

Locking Mechanisms

Some fences (like the Jet and Powermatic) lock only on the front guide rail, see top drawing. While you'd expect these fences to deflect when making a cut, they're rock solid. And unlike most of the other fences that are secured on the front *and* back rails (bottom drawing), they lock parallel to the blade every time.

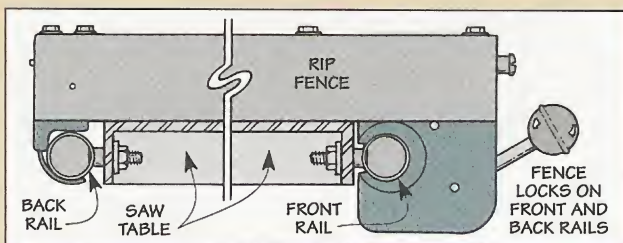
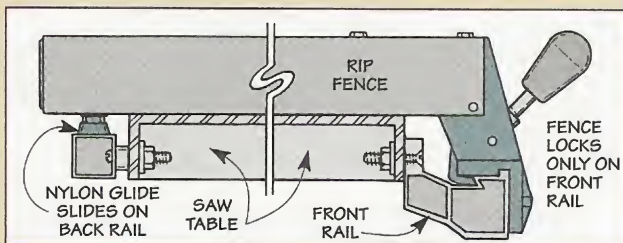

Indicators. When setting the rip fence, a cursor with a hairline indicator on the Powermatic (left) is more accurate and easier to read than the pointer on the Delta fence (right).

Controls & Motor

Q: The controls on a saw make a big difference in how easy and comfortable it is to use. What did you think about the controls?

Steve: For starters, I liked the big, beefy handwheels on the Powermatic that control the height and angle of the blade. (See photos at right.) They're easy to find and comfortable to grasp. And they provide more leverage than the cookie-sized handwheels on the AMT.

Ken: Besides the size of the handwheels, I liked the smooth action of the Powermatic and Jet when adjusting the blade. While the Delta and Grizzly aren't as smooth, at least they're not as stiff as the Sears and AMT saws.

Cary: One problem I noticed is the knob on the AMT that's supposed to lock in the height of the blade just doesn't work. And when I tighten the lock knob on the Delta, the blade creeps about 1/4".



Handwheels. The large handwheel that controls the height of the blade on the Powermatic (left) is more comfortable to grasp. And it provides more leverage than the small handwheel on the AMT (right).

Q: What about the on/off switch?

Ken: It's hard to get used to the toggle switch on the Delta saw. (See photos below.) The rail-mounted switches on the Jet and Sears saws are handier.

Q: One last thing. How would you rate the performance of the saws?

Steve: Just by how easy it is to plow through 2"-thick hard maple, I'd say the Powermatic has the strongest running motor. And the Jet, Delta, and Sears saws

also have plenty of muscle for most of the work I do. But to keep the motors on the AMT and Grizzly saws from bogging down, I had to ease up on the feed rate.

Ken: One concern I have is that the open motors on the Delta and Sears saws can draw in dust — which can significantly shorten the life of the motor. (See photos below.) The other saws have totally enclosed fan-cooled motors to seal out the dust.



Switches. Unlike the small toggle switch mounted on the Delta saw cabinet (left), you don't have to

grope around to find the rail-mounted switches on the Jet (center) or the Sears saw (right).



Motors. An enclosed fan-cooled motor (left) protects against dust that can cause overheating in an open motor (right).

RECOMMENDATIONS

Ken: Picking one table saw out of the bunch is easy for me — I'd go with the Jet in a heartbeat.

I especially liked the smooth action of the fence and the aluminum guide rail. And since it locks parallel to the blade every time, I can rely on it for accurate setups. Finally, with all the plywood I cut, its 30" rip capacity is a real bonus.

Steve: All through the test, two saws kept coming to the top — the Delta and the Jet.

The fit and finish of these saws is excellent. And the heft and machining of the parts told me they're built with quality in mind.

But when push comes to shove, the smooth, accurate fence on the Jet makes it my first choice.

Cary: That's a tough one. I was impressed with the fence, the strong-running motor, and the dust-hookup on the Powermatic.

But the Jet has all that and more, so I chose it instead. Mainly because of its attention to detail. A sturdy base. The beveled front edge on the saw table. Even a handy rail-mounted switch.

Shop Solutions

Small Piece Miter Gauge



■ I make a lot of small picture frames for gifts — the challenge is mitering the ends of these small pieces accurately. It's difficult to hold them when using my standard miter gauge.

To solve this problem, I've made a jig designed for small pieces. It's nothing more than a shallow box attached to a runner.

The runner rides in the miter gauge slot for accuracy. And the workpiece can be clamped to either of the sides closest to the blade, see photo.

To make the jig, cut four pieces of stock for the sides. Simple rabbet joints help align the pieces during glue-up, see drawing. (Note: Size the box so it clears the blade when it's attached to the runner, see detail in drawing)

To strengthen the sides of the box, I glued a piece of $\frac{1}{4}$ " Masonite to the bottom. Finally, glue and screw the box to a wooden runner. Note: To cut accurate miters with this jig, it's critical to make sure the box sits at a 45° angle to the blade.

Shop Tip: The workpiece may shift when making the cut even with clamps. To prevent this, glue sandpaper to the sides of the box.

*Sherwood Cook
Tenants Harbor, Maine*

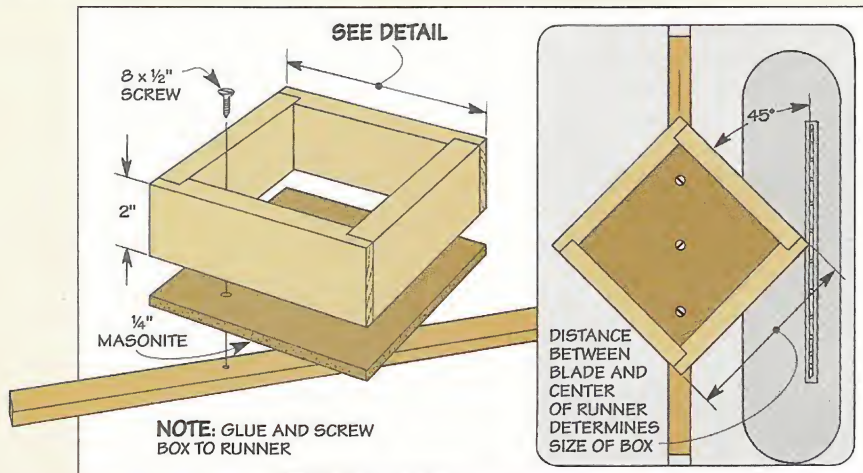

Centering Dadoes

■ The wobble type dado blade I use with my table saw does a great job of cutting dadoes. But setting the rip fence to accurately position the dado can be a real hassle. That's because the indicator for my rip fence is set for a single blade — not a dado.

To solve this, I use the center of my dado blade as a reference and align it with the exact centerline of the dado I want to cut. Then it's easy to measure (or reference) from the center of the blade to the fence and set the exact location for cutting your dado.

Finding the center of a wobble-type blade is simple. Start by adjusting the blade to its smallest

width (usually $\frac{1}{4}$ "). Then use a combination square to measure from the miter gauge slot to the center of one of the saw teeth, see drawing. Finally, transfer this

measurement to the insert and mark or file a notch to indicate the centerline.

*Rex Lawrence
Heber City, Utah*

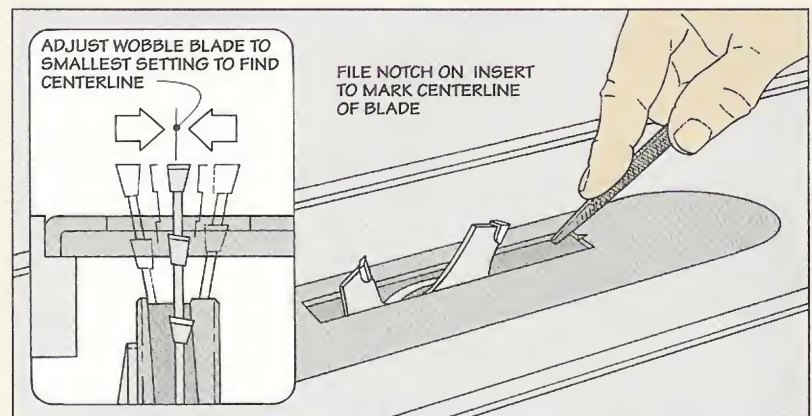

Softwood Grades

I'm having a tough time making sense out of all the different softwood "1by" lumber grades. One local building center carries Select, Quality, and Standard pine. Another sells D-Select, #2, and #3 Common pine. Their prices are competitive, but I'm confused. Am I missing something here?

*C. M. Houghton
Boston, Massachusetts*

Softwood lumber grades can be confusing — unless you know what to look for.

■ It sounds to me like they're both selling the same three grades of lumber — they're just going about it differently. The first building center is probably attaching their own marketing name to each of the three grades. The other is selling the same (or similar) product under the grade name it was given at the sawmill.

STAMP & TAG. What you'll have to do is compare the lumber yourself. The lower grades should have a grade stamp on the face of each board, see photo at right. Higher grades aren't stamped, but they might have a grade tag stapled to one end.

Comparing the stamps (or tags) and appearance, allows you to compare apples to apples.

RULES. But there is a catch here. You need to keep in mind

that there are seven organizations writing softwood rules which regulate over 20 grading inspection agencies throughout North America.

These inspection agencies provide a standardized system for grading forest products produced in their particular region.

This system keeps the sawmills in each region on the same playing field to ensure their customers get a consistent product.

For the most part, each agency

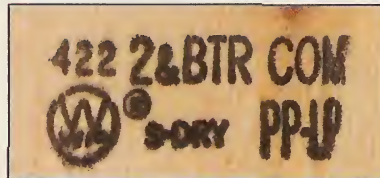

Grade Stamp. This Western Wood Products stamp indicates this is a #2 & Better Common board that's ponderosa pine or lodgepole pine. It came from mill #422 and was planed after it was dried.

follows the same basic rules. But many assign their own names to the different grades. Also, each uses a different grade stamp, which might explain why there's some confusion at the retail level.

The good news is, most lum-

beryards carry only two or three grades of softwood lumber.

GRADES. Softwood that's generally knot-free with a consistent color is assigned one of the "Select" or "Finish" grades, see top photo below. Depending on the mill where the lumber was processed, you might see boards graded B & Better, Clear, Select, C & Better, D-Select, or Finish.

If you don't mind knots (or that's the look you're after), then go with a board graded "Common." Of the "commons," a #1 or #2 Common board will have the fewest number of knots, see bottom photo below. A #3 Common will have more knots, and so on.

(For more on softwood grades send \$2 to: Western Wood Products Assoc., Dept SN, 522 5th Ave. S.W., Portland, OR 97204-2122.)

SPECIES. Another thing to consider is all softwood isn't the same. The stack at the lumberyard might be ponderosa pine, larch, or Douglas fir from Oregon or Washington. It might be white pine from New Hampshire. Or southern yellow pine from Georgia.

In fact, the stack could be a mixture of different softwoods. It's common for western sawmills to mix ponderosa pine with lodgepole pine. Lumber marketed as SPF lumber can be a combination of spruces, pines, and some true firs. And "white wood" can be a mix of just about any western softwood (excluding Douglas fir, larch, cedar, and redwood).

The point is, you'll want to pay particular attention to the *color* and *grain* of each board. By selecting similar-looking boards, you'll end up with a more uniform, consistent project — which will make a big difference when you apply a stain or finish.

Select or Finish (B&Btr., Clear, C&Btr., or D-Select)



Common (#1, #2&Btr., #2 and #3)



Water-Based Top Coats

When water-based top coats first came out, I was like an old dog learning new tricks. After all, they looked *and* acted differently than the solvent-based finishes I'd been using.

What surprised me the most is water-based top coats dry incredibly fast. Depending on the weather, I can apply two or even three coats in *one* day. Yet they still produce a hard, durable finish.

Another thing I like about water-based top coats is they don't smell bad. And you can apply a finish in a basement without worrying about the risk of fire. Even clean-up is easier — just use warm water and soap.

While I appreciate all these things about water-based top coats, they do have a few quirks that I had to get used to.

COLOR. Even though the finish appears milky when you pour it out of the container, it dries clear. The fact that it doesn't "yellow" light colored woods (like pine or maple) is great. But I miss the "warm" color on dark woods like

walnut or cherry. To get this amber color, you can add small amounts of water soluble aniline dyes to the finish.

RAISES GRAIN. Another thing to be aware of is water in the finish will raise the grain of the wood and leave a rough surface. But it's easy to minimize this by sanding with finer grit sandpaper than you normally would (up to

use a paint pad, see photo C.

THIN COAT. Whether you use a brush or pad, the key is to apply as *thin* a coat as possible. (If you're used to solvent-based products, it will feel like you're working too "dry.")

The idea is to lay the finish on in the direction of the grain. Then go back over it (one time only) in the same direction.

Although it's tempting to continue to work the finish, it's best to leave it alone. Any brush marks or bubbles that form will soon disappear as the finish levels out.

ADDITIONAL COATS. After the finish dries, I use an abrasive pad (like a Scotch-Brite pad) to remove any dust "nibs." (Steel wool can leave tiny splinters that will rust.) Then wipe the surface with a damp rag and apply another coat.

BRANDS. There are a number of brands of water-based top coats. Two brands that work well for me are Carver Tripp (available at many hardware stores) and Environmental Friendly water-based finishes, see margin for sources.

All it takes are a few simple tricks to get a professional-looking finish with water-based top coats.

220-grit.) Then, after the first coat dries, knock off the "whiskers" with 320-grit sandpaper.

FILTER. Before applying the finish, it's a good idea to filter it, see photo A below. That's because the solids in the finish can form small lumps like curds in cottage cheese.

APPLICATION. Since the finish sets up fast, it's important to work quickly when applying a water-based top coat. A synthetic bristle brush works well on small projects, see photo B. But to cover large surfaces quickly, I

Sources

Woodworkers' Store
800-279-4441

Woodcraft
800-225-1153

Woodsmith Shop
800-444-7002



A. Filter. To strain out any lumps in the finish, pour it through a paper paint filter into a plastic (or glass) container.



B. Brush. A synthetic bristle brush (nylon or polyester) helps lay down a smooth coat of finish on small pieces.



C. Pad. For large surfaces, a paint pad works best. It loads well and lets you apply the finish quickly and evenly.

Scenes from the Shop



▲ *Can't decide which table saw to buy? Our team of woodworkers tests six popular models under \$700 and offers practical suggestions on what to look for.*



▲ *This adjustable featherboard attaches to your router table (or table saw) to ensure a precision cut. At the same time, it reduces the chance of kickback.*

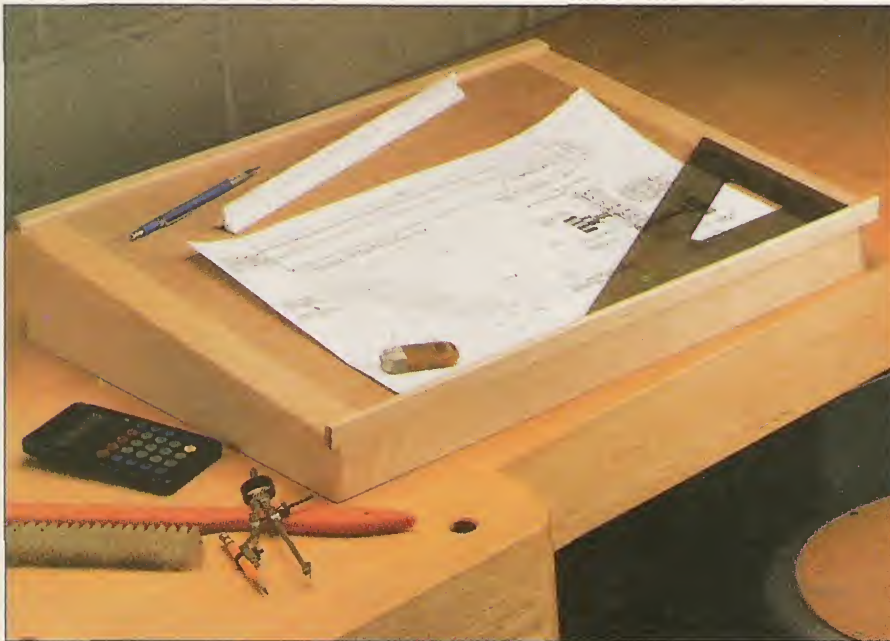

▲ *With a sturdy writing surface that lifts up to provide access to supplies and materials, this lap desk doubles as a handy drafting table. And its compact size makes it easy to store the desk conveniently out of the way.*

ShopNotes
TIPS • TOOLS • TECHNIQUES