

TIPS • TOOLS • TECHNIQUES

# ShopNotes®

Vol. 4

Issue 23

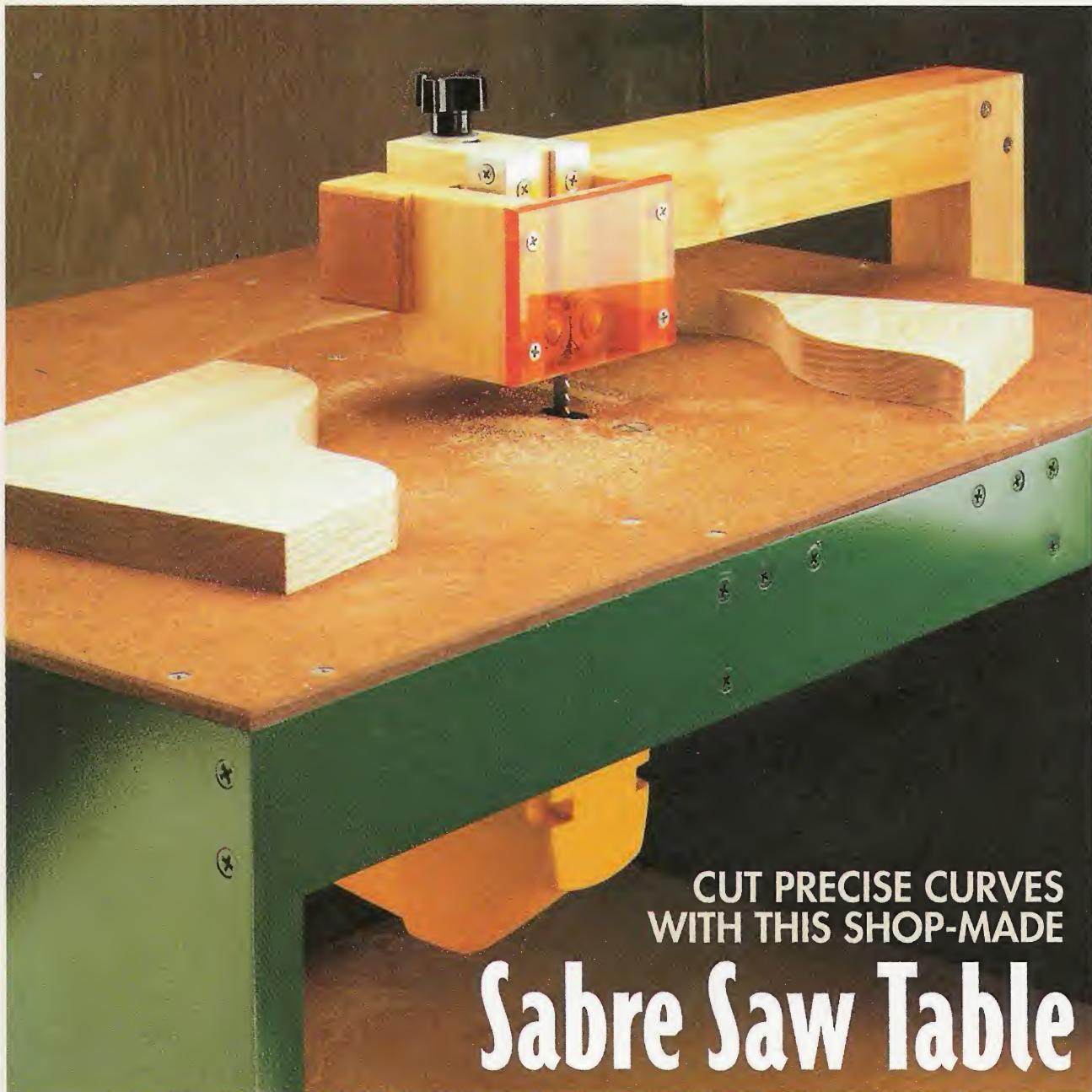

CUT PRECISE CURVES  
WITH THIS SHOP-MADE

## Sabre Saw Table

- Blade Storage Cabinet
- Tips for Buying Lumber
- Random-Orbit Sanders
- Turned Shop Mallets



# ShopNotes®

Issue 23 September 1995

**PUBLISHER** Donald B. Peschke  
**EDITOR** Richard S. Peters  
**ASSOCIATE EDITORS** Tim Robertson  
 Phil Totten  
 Cary Christensen  
**ART DIRECTOR** Kurt Schultz  
**SENIOR ILLUSTRATOR** Roger Reiland  
**ILLUSTRATORS** Mark Higdon

#### CREATIVE RESOURCES

**CREATIVE DIRECTOR** Ted Kralceik  
**EXECUTIVE EDITOR** Douglas L. Hicks  
**DESIGN DIRECTOR** Ken Munkel  
**SENIOR DESIGNER** Kent Welsh  
**SHOP MANAGER** Steve Curtis  
**SHOP CRAFTSMAN** Steve Johnson  
**PHOTOGRAPHER** Crayola England  
**ELECTRONIC PUBLISHING** Douglas M. Lidster  
**ELECTRONIC GRAPHICS** Chris Glowacki  
**ELEC. COMMUNICATION** Gordon C. Gaippe  
**GRAPHIC ARTIST** Cheryl L. Cynor

#### CIRCULATION

*Subscription Mgrs.:* Sandy Baum, Troy Dowell, Paige Rogers ■ *Assistant Subscription Mgrs.:* Shane S. Francis, Julie Greenlee ■ *Newsstand Manager:* Kent A. Buckton

#### CORPORATE SERVICES

*Plan. Director:* Jon Macarthy ■ *Controllor:* Robin Hutchinson ■ *Senior Acct.:* Laura Thomas ■ *Bkpr.:* Holly Lucas ■ *Production Dir.:* George Chmielarz ■ *Prod. Mgr.:* Carol Quijano ■ *Prof. Development:* Joyce Moore ■ *Net. Adm.:* Nick Thielen ■ *Admin. Assists.:* Cheryl Scott, Julia Fish ■ *Receptionist:* Jeanne Johnson ■ *Building Maint.:* Ken Griffith

#### MAIL ORDER

*Operations Director:* Bob Baker ■ *Art Director:* Cindy Jackson ■ *Materials Mgr.:* Mark Mattussi ■ *Customer Service Mgr.:* Jennie Enos ■ *Warehouse Supervisor:* Nancy Johnson ■ *Buyer:* Linda Jones ■ *System Operator:* Tammy Aldini ■ *Team Leader:* Karla Cronin ■ *Technical Support:* David Stone ■ *Customer Service Reps.:* Jennifer Murphy, Joy Krause, Sara Kono, Anna Cox, Adam Best, Kristi Andrews ■ *Warehouse:* Gloria Sheehan, Chuck Carlson, Sylvia Carey, Larry Prine

ShopNotes® (ISSN 1062-9630) is published bimonthly (Jan., March, May, July, Sept., Nov.) by Woodsmith Corporation, 2200 Grand Ave., Des Moines, IA 50312. ShopNotes® is a registered trademark of Woodsmith Corp. ©Copyright 1995 by Woodsmith Corporation. All rights reserved.  
**Subscriptions:** Single Copy, \$4.95. One year subscription (6 issues), \$19.95. Two years (12 issues), \$35.95. Canada/Foreign, add \$5.00 per year.  
**Second Class Postage Paid** at Des Moines, IA and at additional offices.  
**Postmaster:** Send change of address to ShopNotes, Box 11204, Des Moines, IA 50340-1204  
**Subscription Questions?** Call 1-800-333-5854, 8am to 5pm, Central Time, weekdays.  
**E-Mail.** Prodigy: EDJE97A, CompuServe: 75330,2301, Internet: 75330.2301@compuserve.com, America On-line: Shopnotes.

## WoodNet™

#### COMPUTER BULLETIN BOARD FOR WOODWORKERS

- Project plans and photos to download
- Woodworking Techniques Forum
- Indexes for Woodsmith & ShopNotes
- First month FREE for PC or MAC

To log on to WoodNet, call 1-515-245-9663. If you have any questions, please give us a call: (voice) 1-515-282-7000 M-F 9-5 CST.

## EDITOR'S NOTE

# Cutoffs

Ask any woodworker about a project he has just completed and the first thing he'll mention is how he *didn't* follow the plans. Sure, the basic design is the same. But there's always that natural tendency to change something — to put your own stamp on the projects that you build.

Maybe the dimensions are slightly different. Or you decided to use a different wood, joint, or profile on an edge. There's nothing wrong with personalizing a project. Just be aware that a little change here or there can often have a dramatic impact somewhere else.

**TEST THE IDEA.** The best way I've found to prevent a surprise like this from happening later is to test the idea up front. Depending on the change, I may build a small-scale model. Other times I'll make a prototype, or just mock up a joint or an edge.

Building prototypes and mock-ups isn't anything new. All designers learn the value of these early on. They know they're a great way to try out new ideas while working out any possible bugs.

The design staff here at ShopNotes is no different. After an initial design concept meeting, I'll often find Ken or Kent down in the shop building a section of a bench top or struggling with the mechanics of a new jig. It's always fun to watch the modifications they make as the project progresses.

**SABRE SAW TABLE.** That was the case with the Sabre Saw Table in this issue. It started out as just a box with a sabre saw bolted upside down underneath. Then someone suggested it would be handy to be able to cut circles with it.

So the first version Kent built had a sliding index pin built into the top.

**BENT BLADE.** The only problem was it *didn't* work. The blade had a tendency to bend during a cut. And this was exaggerated when the workpiece was rotated to cut a circle. Although the resulting wheel was nice and round, the edges were *beveled*.

It was obvious we needed something to hold the blade straight. Kent mentioned he had an idea. So I was intrigued when he asked me to come down to the shop a couple days later.

**SUPPORT.** Gone was the sliding index idea. In its place was a unique overarm support. One end of the support held a pair of bearings that kept



the blade rigid, while still allowing it to move up and down, see photo.

After some testing, we noticed the workpiece had a tendency to skitter around during a cut. At the same time, we weren't comfortable with the blade being exposed. Kent's solution took care of both problems. (For more on this, see the article on page 16.)

**NEW IDEAS.** But even though our design department never ceases to amaze me, I'm still in awe at the multitude of ideas that come in daily from readers. You'll notice that many of our Shop Solutions are creative modifications to projects in prior issues.

So take the time to try out your new ideas. Build a prototype or a model *before* you cut into that precious stack of cherry or walnut. You'll save yourself some aggravation. And who knows. Maybe you'll come up with a different technique or a new idea.

# Contents

## Projects & Techniques

### Saw Blade Storage \_\_\_\_\_ 4

Protect and organize your valuable saw blades with this handy storage cabinet.

### Turning with a Spindle Gouge \_\_\_\_\_ 6

This versatile turning tool can do it all — from roughing out spindles to shaping decorative coves and beads.

### Shop-Made Mallets \_\_\_\_\_ 8

Two traditionally designed shop mallets that can be turned with just a spindle gouge and a parting tool.

### Sabre Saw Table \_\_\_\_\_ 16

A simple table and a unique adjustable arm convert your hand-held sabre saw into a precision cutting tool.

### Dowel Joinery \_\_\_\_\_ 22

It's easy to make strong, accurate dowel joints with just an electric drill and one of our simple shop-made jigs.

## Departments

### The Small Shop Selecting Hand Tools \_\_\_\_\_ 10

What are the most practical hand and portable electric tools for the small shop? Here's a look at our top picks.

### Selecting Tools Random-Orbit Sanders \_\_\_\_\_ 12

Our three-man testing team offers suggestions on which palm-grip random-orbit sander is best for you.

### Great Tips Lumber Storage Tips \_\_\_\_\_ 24

Here's a collection of our favorite lumber storage tips.

### Finish Room Varnish \_\_\_\_\_ 26

A hard, durable finish for your special projects.

### At the Store New Products \_\_\_\_\_ 27

Tape Mate, Veritas Brass Insert Knobs, and Nobex Squares.

### Readers' Tips Shop Solutions \_\_\_\_\_ 28

Six shop-tested solutions from our readers.

### Lumberyard Buying Lumber \_\_\_\_\_ 30

A step-by-step approach to buying hardwood lumber.



Saw Blade Storage page 4



Shop-Made Mallets page 8



Random-Orbit Sanders page 12

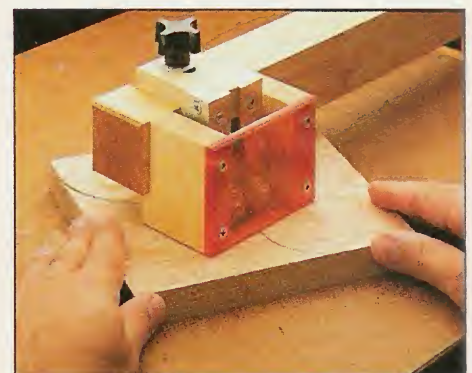

Sabre Saw Table page 16

# Saw Blade Storage

*A compact cabinet that stores, organizes, and protects your valuable saw blades.*



The simplest way to store a saw blade is to hang it on a nail in the wall. But if you have as many blades as I do, there's a problem. You can either hang them all on the same nail and run the risk of damaging the teeth. Or hang them on separate nails and lose valuable wall space.

To solve both problems, I built a saw blade cabinet that can sit on a workbench or be screwed to a wall, see photo. It has nine single trays that can each handle a 10" (or smaller) saw blade. And one double-size tray for a dado blade.

I began by building the cabinet

that holds the pull-out trays. It's just an open plywood box with grooves cut in the sides for the trays, see Fig. 1.

**SIDES.** When laying out the sides (A), I oriented the grain to run the same direction as the grooves, see Fig. 1. This way, there's less chance of chipping the face veneer when the grooves are cut later.

**GROOVES.** After the sides are cut to size, there are two sets of 1/4"-wide grooves to cut. The first set of grooves forms half of a locking rabbet that joins the top and bottom to the sides, see Figs. 1

and 1a. The second set holds the saw blade trays, see Fig. 1b.

I cut all of these grooves with a dado blade in the table saw. And to match up the grooves in each side piece, I used the rip fence as a stop and the same setup for each opposing groove before moving on to the next set.

**RABBETS FOR BACK.** In addition to the grooves, a rabbet is cut in the back edge of each side piece. This

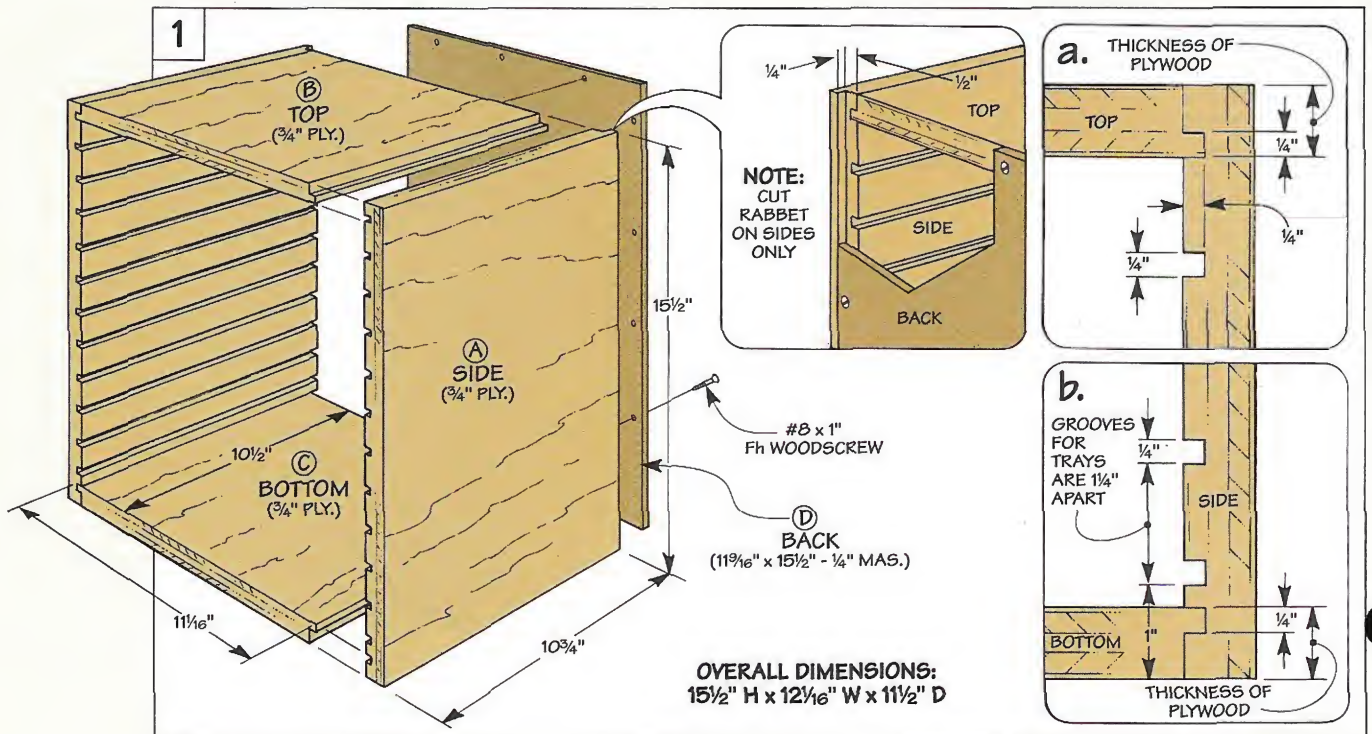

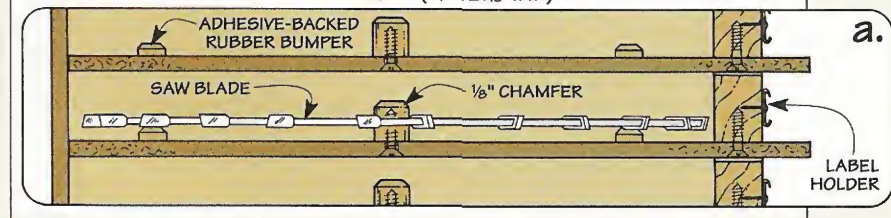
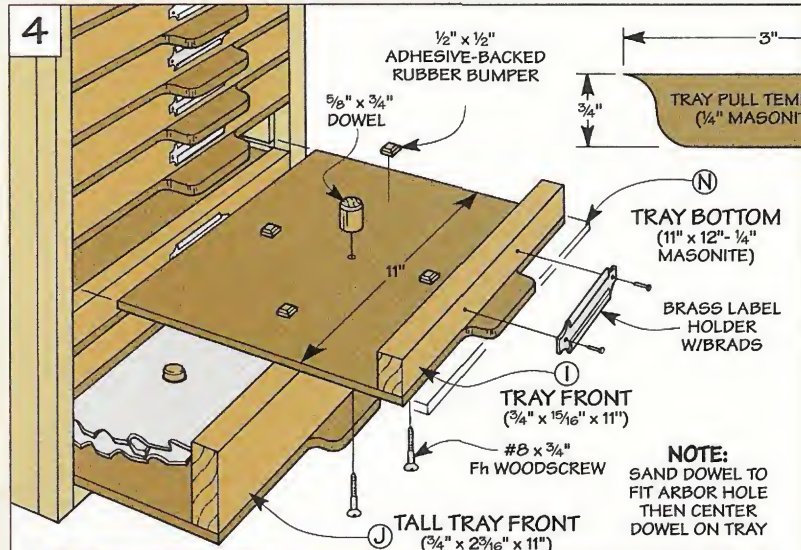
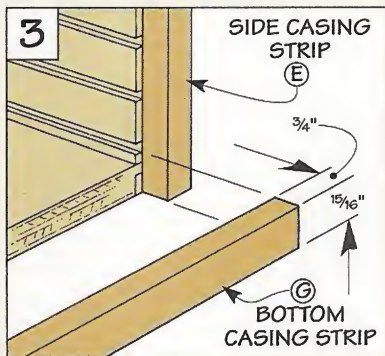
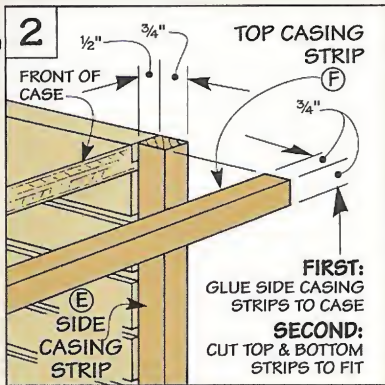

rabbit accepts a back that's added later, see detail in Fig. 1.

**TOP & BOTTOM.** Now work can begin on the *top* (B) and *bottom* (C), see Fig. 1. To leave room for the back, the length (depth) of each piece is  $\frac{1}{4}$ " less than the sides ( $10\frac{1}{2}$ " ), see Fig. 1. And they're cut to a width of  $11\frac{1}{16}$ ". (Note: For appearance, the grain direction of the top and bottom should match that of the sides.)

To complete the top and bottom, a rabbet is cut in the ends. It forms a tongue to fit the grooves cut earlier, see Figs. 1a and 1b.

**BACK.** After gluing and clamping the cabinet together, cut a *back* (D) to fit from  $\frac{1}{4}$ " Masonite and screw it in place, see Fig. 1.

**FACINGS.** To complete the cabinet, I covered the plywood edges with facing strips cut from  $\frac{3}{4}$ "-thick maple, see Figs. 2 and 3. Start by gluing on the *sides* (E). Then cut a *top* (F) and *bottom* (G) to fit and glue them in place.

**TRAYS.** Now the cabinet is ready for the trays. Whether you're building trays for single blades or for a dado blade, each is

made up of a bottom and a tray front, see Fig. 4. The only difference is the tray for the dado blade has a taller front.

**BOTTOMS.** Each *tray bottom* (H) is extra long (12") to allow for a pull that's routed later. To determine the width of the tray, measure the distance between the grooves in the sides and subtract  $\frac{1}{16}$ " for clearance (11").

**FRONTS.** The next step is to add a *tray front* (I) to nine of the tray bottoms. And a *tall tray*

*front* (J) to the remaining bottom for your dado blade, see Fig. 4.

After the fronts are screwed in place, the pulls can be routed, see Fig. 4 and the box below.

**HARDWARE.** To secure each saw blade, I screwed a short length of dowel to the center of each tray. And to raise the blade up so it's easy to lift out, I added four self-adhesive rubber "feet," see Fig. 4.

Finally, so you can locate a blade at a glance, add a brass label holder to each tray front.

### Hardware

- (12) #8 x 1" Fh Screws
- (50) #8 x  $\frac{3}{4}$ " Fh Screws
- (40)  $\frac{1}{2}$ " Rubber Bumpers
- (10)  $\frac{1}{2}$ " Label Holders

To order a complete hardware kit, call ShopNotes Project Supplies at 1-800-444-7527. 523-6823-100... \$19.95

## Pattern Routing

One of the quickest ways to make identical parts is to use a template and a flush trim bit. Just carpet tape the template to a blank and set the bearing on the flush trim bit to ride against the template.

For the pulls on the saw blade cabinet, the template is made up of two parts: a small piece of  $\frac{1}{4}$ " Masonite shaped like a pull (see Fig. 4), and the hardwood front of each tray, see photo at right.



**Identical Parts.** A quick way to produce identical parts is to make a template and use it as a pattern for a flush trim bit to follow.

# Turning with a Spindle Gouge

**T**here's a rack full of turning tools next to my lathe. And to be honest, I could probably get along without some of the more specialized tools. But take away the spindle gouges and I'd be like a mechanic without a wrench.

That's because when turning between centers, a spindle gouge gives me a quick, easy way to make a number of different cuts — like roughing out a cylinder, cutting a cove, or turning a bead.

The reason is the tip of a gouge is shaped like a lady's fingernail, see margin. So no matter what size gouge you're using ( $\frac{1}{4}$ ",  $\frac{1}{2}$ ", or  $\frac{3}{4}$ "), there are no sharp corners to "catch" the workpiece.



▲ A spindle gouge makes quick, easy work of roughing out a cylinder, cutting a cove, or turning a bead.

## Roughing Out

Whether you're turning a block of wood or a round log, a spindle gouge makes quick work of roughing it down to a cylinder.

**TOOLREST & GRIP.** To support the gouge, I position the toolrest about  $\frac{1}{4}$ " in front of the workpiece and  $\frac{1}{4}$ " below its centerline. Combining this with an overhand grip gives me plenty of control when making a cut, see Step 1.

**CUTTING EDGE.** The quality of this cut depends on how you position the cutting edge of the gouge. I start with the handle quite low so the cutting edge isn't even in contact with the wood, see Step 2. Then simply raise the handle until you get a shaving.

Once the gouge starts to cut, just slide it along the tool rest. Angling the gouge a bit in the direction you want to cut and rolling the blade slightly will pare off shavings like you're peeling a potato, see Step 3.



Because of its fingernail shape, a spindle gouge doesn't have any corners to "catch" the workpiece.



**Step 1.** With your hand against the tool rest, wrap your fingers around the blade in an overhand grip.



**Step 2.** Starting with the handle of the gouge down low, gradually lift up on it to produce a shaving.

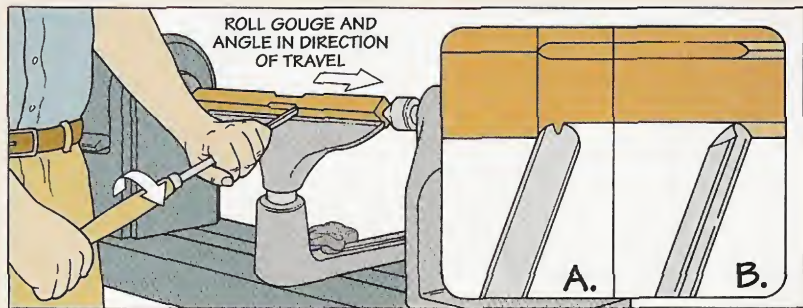

**Step 3.** As you slide the gouge along the tool rest, angle it in the direction of travel and roll the

blade slightly in the same direction. Then just repeat the process until a rough cylinder is formed.

### Cutting a Cove

The curved tip on a spindle gouge also makes it a perfect tool for turning a cove. Like a shovel, it's used to "scoop" out material from both sides of the cove down to the center of the hollow.

**ENTRY POINT.** The thing to be aware of is the gouge has a tendency to skid to one side at the start of the cut. To prevent this, I establish an "entry point" for the

blade by making a shallow ( $\frac{1}{32}$ " cut with a parting tool, see Step 1.

**SIZE.** Another thing to keep in mind is the size of the gouge. To give the cutting edge room to work, you'll need to use a gouge that's *smaller* than the desired width of the cove. For example, I use a  $\frac{1}{2}$ " gouge to cut a  $\frac{3}{4}$ " cove.

**CUT DOWNHILL.** To produce a clean, crisp surface, the idea is to cut "downhill" by working from a

large diameter to a small one. Start with the gouge on its side and push the tip slowly (but firmly) into the workpiece, see Step 2. Then roll the blade on its back to scoop out one side of the cove.

To turn the other side, just repeat the process. Depending on the size and shape of the cove, you may need to make several cuts.



▲ To create a clean, crisp cove, make a scooping cut with the gouge.

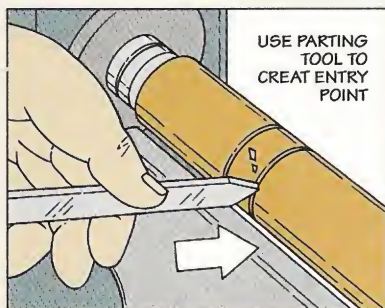

**Step 1.** After laying out the cove, push the tip of a parting tool into the work to make a shallow V-cut.

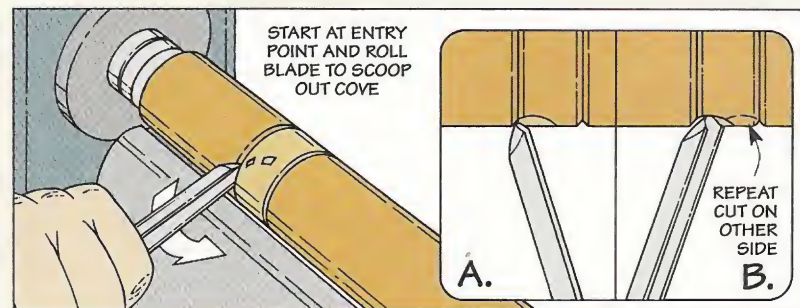

**Step 2.** With the flute on the gouge facing the intended cove, push the tip firmly into the V-cut (left).

Then roll the gouge on its back to scoop out one side of the cove (right). Repeat for the other side.

### Cutting a Bead

The shape of a bead is the exact opposite of a cove. So simply by reversing the direction of cut, you can turn a bead with a spindle gouge.

**ROLL.** Instead of a scooping cut, the bead is formed by rolling the gouge — first to one side, then the other. As before, working from a large diameter down to a small one reduces tearout.

**REMOVE WASTE.** But before turning the bead, there's one

thing to do. To provide clearance for the gouge to work, you'll need to remove the waste from the sides of the bead, see Step 1.

**TURN BEAD.** Now you can turn the bead. Start with the gouge on its *back* and the handle well down so the bevel is rubbing on the workpiece, see Step 2.

Although the gouge won't be cutting yet, that's okay. It gives you a chance to think about making a smooth, flowing cut so you'll

end up with a bead that has a uniform shape on each side.

Each side of the bead is cut by blending several different motions into one continuous cut, see Step 2. What I've found works best is to remove small amounts of material until you're satisfied with the shape. Then just turn the other side of the bead so it matches.



▲ A simple bead is formed by rolling the gouge over on its side.

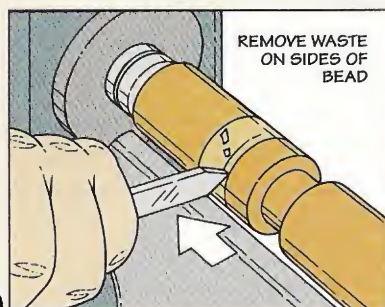

**Step 1.** To give the gouge room to work, remove the waste on the sides of the bead you plan to cut.

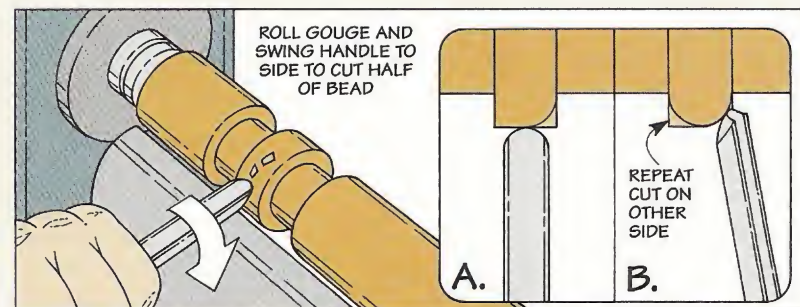

**Step 2.** Start with the gouge on its back and the handle well down. Then raise the handle and

roll the gouge on its side. At the same time, swing the handle to the side and push the gouge forward.



# Shop-made Mallets

*A simple design makes it quick and easy to turn these mallets on the lathe.*

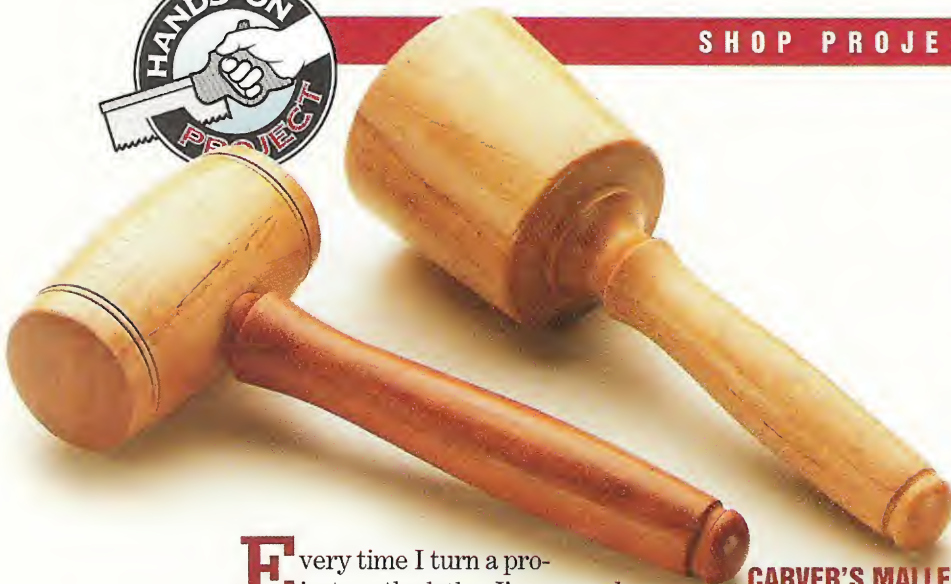

**E**very time I turn a project on the lathe, I'm amazed at how quickly it takes shape. And these mallets are no exception.

With just two basic tools (a spindle gouge and a parting tool), you can spend a morning making shavings and end up with a mallet you'll use for years. (For more on using a spindle gouge, see page 6.)

**TWO MALLETS.** Depending on the type of woodworking you do, you may want to turn one (or both) of these mallets. The left of the carver's mallet (on the right in the photo above) allows you to strike a chisel with a firm, solid blow. While the carpenter's mallet (left) is best suited for tapping a chisel or for light assembly work.

## CARVER'S MALLET

Like a traditional carver's tool, both the head and handle of this mallet are turned from a single block of wood. I made the block by gluing up three pieces of 1 3/4"-

thick hardwood (maple), see Fig. 1.

**HEAD.** After mounting the block and roughing out the cylinder, you can start on the head of the mallet. To make it easy to strike a chisel squarely on the handle, there's a gradual taper cut on the head.

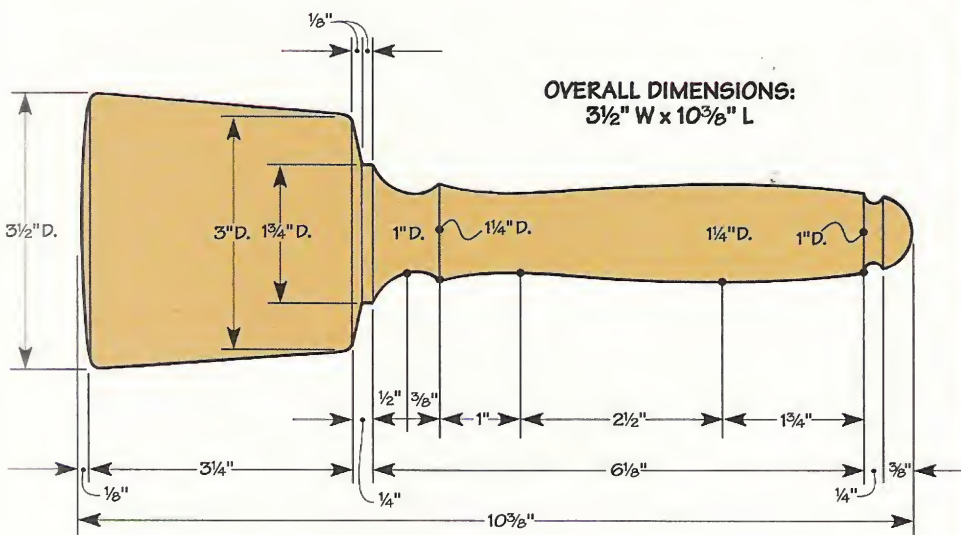
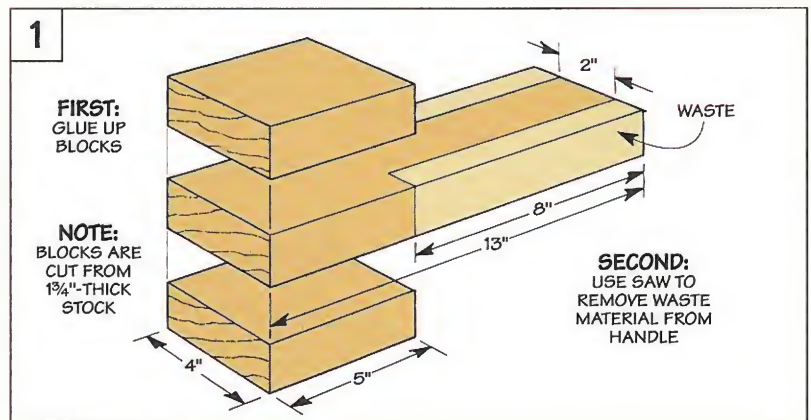

## Carver's Mallet

- 1** First, rough out the block with a spindle gouge. Then use a parting tool to define the head and the end of the handle.
- 2** After cutting a gradual taper on the head, switch to a parting tool to establish the step at the top of the handle.
- 3** Using a spindle gouge, scoop out the wide cove at the base of the head and shape the curves on the handle.
- 4** The narrow cove and the button at the end of the handle can also be turned using a small spindle gouge.
- 5** Finally, use a parting tool to cut a slight curve at the large end, sand, and remove the mallet from the lathe.



(For a step-by-step procedure, see drawing and box on page 8.)

**HANDLE.** The handle of the mallet is designed to be held right below the head — like “choking up” on a baseball bat. The large cove at the base of the head provides a comfortable grip. And a gentle curve that swells toward the cove and button at the end of the handle keeps your hand from slipping.

**CARPENTER'S MALLET**

I made the carpenter's mallet by turning *two* separate blanks — a maple one for the head, and a cherry turning square for the handle, see drawing and box below.

**HEAD.** The head curves gently from the center to a small bead

near each end. And here again, the striking surface (the ends) taper slightly. After removing the head from the lathe, I drilled a hole (mortise) for the handle using the simple jig shown below.

**HANDLE.** Except for a tenon on one end that fits in the mortise, the handle is identical to the one on the carver's mallet. To sneak up on a perfect fit, remove small amounts of material and check the fit of the tenon frequently.

**WEDGE.** All that's left is to assemble the mallet. To keep the head from loosening up, the handle is locked in place with a wedge. This is just a matter of cutting a kerf in the tenon, applying glue, and driving in a wedge, see Fig. 2.

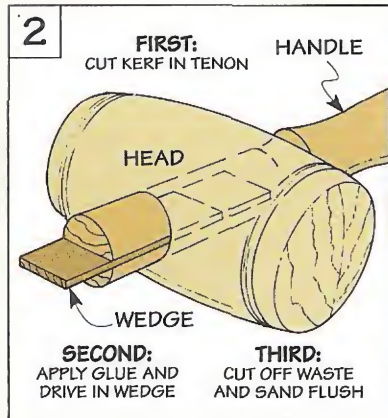
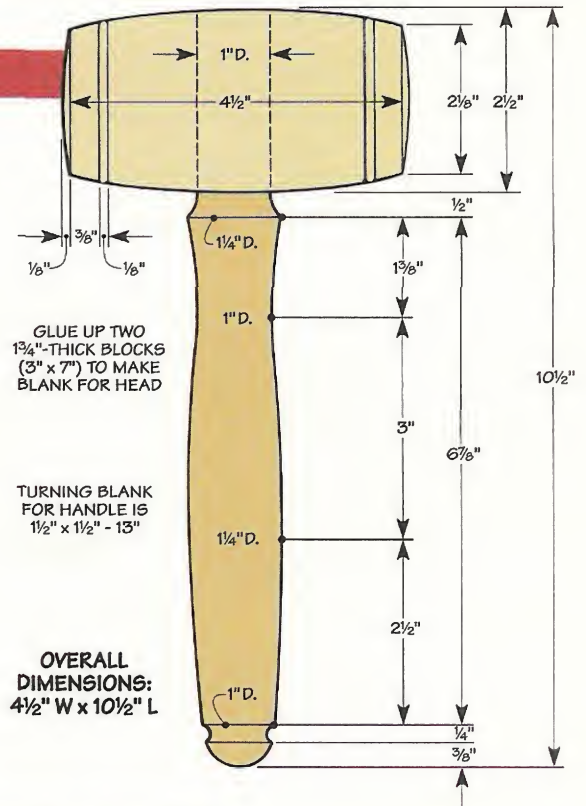

### Carpenter's Mallet

Head	Handle
<p><b>1</b> Rough out a cylinder with a spindle gouge, and use a parting tool to define the ends of the head.</p> <p><b>2</b> Now use a spindle gouge to shape the curves that run from the center of the head to each end.</p> <p><b>3</b> Complete the head using a parting tool to form two small beads and to cut the curves on the ends.</p>	<p><b>1</b> With the cylinder roughed out, mark the end of the handle and the flare at the base of the tenon.</p> <p><b>2</b> Shape the handle between these marks with a spindle gouge. Then turn the cove and button at the end.</p> <p><b>3</b> Using a spindle gouge, turn the tenon on the end of the handle to fit the mortise in the mallet head.</p>

**Drilling Jig**

Drilling a hole through a round workpiece presents a couple of problems. First, it rolls around. And second, you need to drill through from both sides to prevent chipout, yet still manage to keep the holes aligned.

This simple jig solves both problems. To hold the head steady, two V-shaped blocks are screwed to a scrap 2x4, see drawing. And a dowel fits into a hole drilled in the 2x4 to automatically align the holes, see photo.

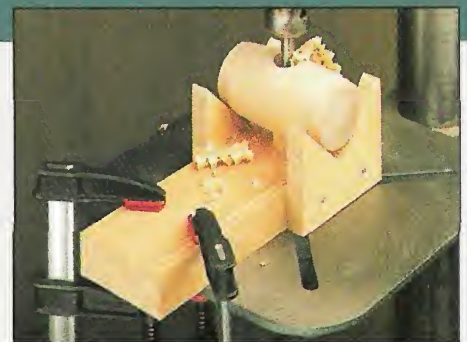
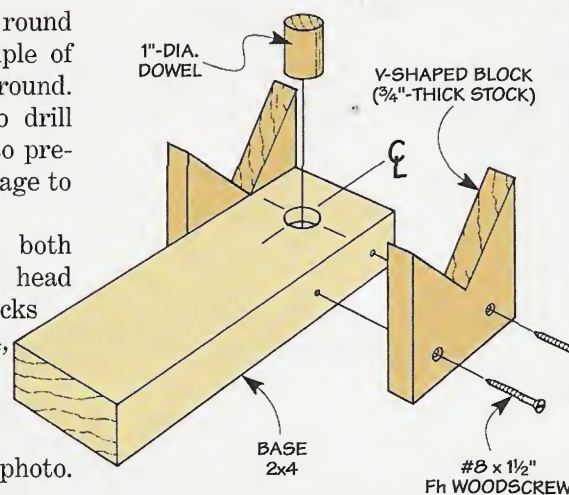

▲ The secret to this jig is to clamp it in place so the bit aligns with the hole in the 2x4 that holds a dowel. Fitting the hole that's drilled in one side of the head over the dowel ensures that the hole drilled from the opposite side lines up.

# Selecting Hand Tools



**Power Tools.** When outfitting your shop with power hand tools, plan each purchase ahead of time and shop around for the best deal.



**Hand Tools.** A chisel set, a few hand planes, and a square or two are just a few of the hand tools that should be in every woodworking shop.

**L**ike many woodworking shops, my shop started out as a collection of hand tools used mainly for home improvements. When a bedroom door no longer closed, I bought a plane to make it fit again. To build a fence, I bought a circular saw and built a pair of sawhorses to help get the job done, see box on next page.

After a while, I had acquired enough tools to tackle my first woodworking project. In hindsight, I wish I had given more thought to the tools I had purchased — a little more planning could have saved some money.

The following hand tools are those I'd recommend to anyone getting into woodworking. To keep costs down, plan ahead and watch for sales at hardware stores and home improvement centers.

You might also consider purchasing from mail-order catalogs, see sources at left. These tools may cost less than those at a retail outlet. And some catalogs don't charge for shipping. Also, if you're not living in the state where the catalog is located, you might not have to pay state sales tax.

One other thing. I recommend buying the best tools you can afford — better tools last longer. And they'll out perform their less-expensive competitors.

## POWER TOOLS

Most woodworkers begin their collection with power tools. And the most practical one to start with is the circular saw.

**CIRCULAR SAW.** A circular saw is great for cutting up plywood. And with the help of a straight-edge, it can be used to rip or crosscut softwood and hardwood.

Most circular saws fall in a price range of \$30 to \$150 — with the better saws costing over \$65. So it's a good idea to compare them closely and base your decision on how it will be used, and how much you'll use it.

Once you've made your pick, check to see what type of blade it comes with. If it isn't carbide-tipped, invest in a quality combination-tooth blade (\$10 to \$15). What you'll get is a blade that cuts smoother with less chipout. This means the motor won't work as hard and will run cooler — which

should make the saw last longer.

**ELECTRIC DRILL.** My next tool of choice is an electric hand drill with a  $\frac{3}{8}$ " chuck. It's good for drilling pilot holes for screws and other fasteners. They're great for assembly work or things like dowel joinery, see page 22.

When looking for a hand drill, there are two roads to follow. You can buy a corded drill (around \$30). Or a cordless, rechargeable drill (\$100 and up). The advantage of a corded drill is they cost a lot less than a cordless drill.

The advantage of a cordless drill is its portability. No more hassle with tangled extension cords. And you won't have to drag one through the house every time you want to hang a picture.

**RANDOM-ORBIT SANDER.** Since most projects need some sanding, I'd buy a random-orbit sander. They're hard to beat for removing planer marks, chipout, and scratches. Expect to pay around \$75 for a good one. (For more on these, see the tool review beginning on page 14.)

**ROUTER.** I use a router in just about every project I build —

## Sources

Constantines  
(800-223-8087)  
Garrett Wade  
(800-221-2942)  
Tool Crib  
(800-358-3096)  
Tools on Sale  
(800-328-0457)  
Trendlines  
(800-767-9999)  
Woodcraft  
(800-225-1153)  
Woodworkers' Store  
(800-279-4441)  
Woodworkers Supply  
(800-645-9292)

whether it's routing a groove, a dado, or just a decorative profile. This versatile tool can even be mounted upside down in a shop-made or purchased table for use as a small shaping tool.

My first router had a  $\frac{3}{4}$  hp motor with a  $\frac{1}{4}$ " collet. But now I use a  $1\frac{1}{2}$  hp router with interchangeable  $\frac{1}{4}$ " and  $\frac{1}{2}$ " collets. The two different collets allow me to use my old  $\frac{1}{4}$ " bits, but any new bit I buy has a  $\frac{1}{2}$ " shank.

There are a number of good routers to choose from. Prices range from \$70 to \$200. And you can find good-quality, carbide bits for around \$20 each.

**SABRE SAW.** When you need to cut a curve or a circle, you can use a coping saw (\$15). But a sabre saw is quicker. And it can cut through thick stock much easier.

If you're only going to use a sabre saw every now and then, I don't recommend spending more than \$50. But if you think it's a tool you'll use a lot, especially with a stand (like the one shown on page 16), consider spending more for a higher-quality tool.

## HAND TOOLS

In addition to the basic hand tools (like hammers, pliers, and screwdrivers), you'll need a few others

for woodworking.

**CHISELS & Mallet.** My favorite hand tool is the chisel. I use it all the time to cut joinery (like dovetails and mortises) or to fit parts together during assembly.

A quality set of chisels isn't cheap. It'll cost about \$40 to \$50 — but like everything else, you could spend more to get more. While you're at it, pick up a wood mallet (\$20) or make yourself one, see page 8. (A wood mallet is easier on the handles of your chisels.)

**PLANES.** You'll also need a couple of good hand planes. A jack plane (\$70) is good for edge jointing, smoothing, and flattening lumber. A low-angle block plane (\$45) is useful for trimming and fitting parts. Also, a low-angle block plane is the perfect tool for trimming end grain.

**CABINET SCRAPER.** A cabinet scraper is an excellent way to obtain glass-smooth wood. Unlike the large, thick curls a hand plane produces, a cabinet scraper produces micro-thin shavings.

In fact, some woodworkers don't even use sandpaper. They'll scrape an entire project smooth, then apply the finish. A cabinet scraper can last a lifetime, and best of all, they cost less than \$10.

**JAPANESE SAW.** To cut wood

## The Essentials

### Power Tools

- Circular Saw (with carbide blade)
- Electric Drill ( $\frac{3}{8}$ " chuck)
- Random-Orbit Sander
- Router (with carbide bits)
- Sabre Saw

### Hand Tools

- Chisel Set & Mallet
- Block Plane & Jack Plane
- Cabinet Scraper
- Japanese Saws
- Combination or Try Square

by hand, I prefer a Japanese saw (\$30 to \$60). These saws are designed to cut wood quickly, cleanly, and accurately. They have razor-sharp teeth and cut on the pull stroke for better control. (This is especially useful when cutting dovetails and tenons.)

**SQUARES.** Finally, no shop is complete without an accurate square for checking inside and outside corners. For most projects, a small try square (\$15 to \$50) with a 5" blade is all you'll need. But a combination square (\$50) is also nice for checking set-ups and mitered corners.

## A Place to Work

Even though they're not considered hand tools, a solid workbench and a pair of sawhorses are essential tools to have in the shop, see drawings.

Quite often they're one of the first things you'll build for your shop: the workbench for general woodworking, and the sawhorses to support and work on oversized projects. (And along with a sheet of plywood, sawhorses can even be used to create a quick temporary work surface.)

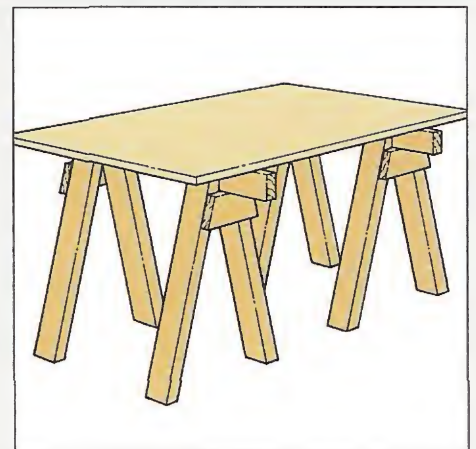
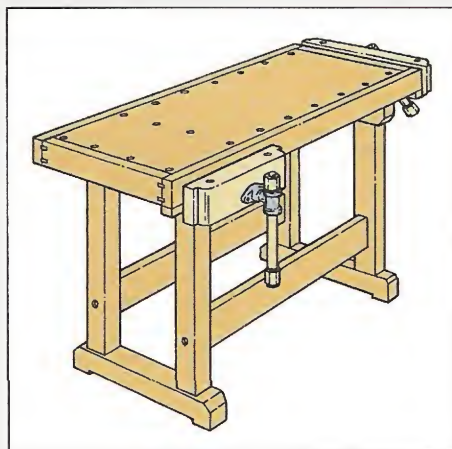

# Random-Orbit Sanders

*If you're buying a random-orbit sander, our hands-on test of seven palm-grip models will steer you in the right direction.*



**W**e bought two random-orbit sanders for the shop a few years back. And while each sander is different (one is held by the body like a right-angle grinder; the other has a pistol grip handle) both sanders do exactly what they promised.

One of the best things is they remove material quickly. That's because their sanding pads spin like a disc sander. At the same time, the pads orbit in a random

motion that leaves the surface nearly free of swirl marks.

Because this dual action is such an efficient method of sanding, several different manufacturers have come out with their own random-orbit sander. And unlike the sanders we bought, many of them incorporate a more compact body that's designed to be held with a palm grip.

**TEST CRITERIA.** To find out which of these palm-grip sanders

is best, we bought and tested *all* the models that are currently available, see photos below.

Some of the tests (like sanding a rough-sawn board so it's smooth) showed how fast the sander could remove stock, see box on the opposite page. Other tests gave us a good idea if the sander left cross-grain scratches or swirl marks.

**TEAM.** Like our other tool reviews, we put together a team of three people with different woodworking experience to test the sanders. *Cary* is just getting started in woodworking. *Steve* is an intermediate woodworker. And *Ken* is a professional cabinetmaker.

Of course, having three different viewpoints can lead to having more than one "best" sander. But that's okay. This way, you can use the comments of the person whose experience is closest to yours to help select a sander that's best for you.

**Q:** *These sanders come in a variety of shapes and sizes. Which one provides the most comfortable grip? And how does the grip affect your control when sanding?*

**Ken:** Depending on the sanding job, I change grips back and forth. When I'm working in a tight spot, holding the body of the sander gives me the best control.



**Porter Cable 333**  
800-487-8665  
\$79.95



**Ryobi RS-112**  
800-525-2579  
\$49.99



**Black & Decker 2771**  
800-544-6980  
\$79.95



**Wen 15**  
800-462-3630  
\$40



**Sears 27714**  
800-290-1245  
\$39.99



**Makita B05001**  
800-487-8665  
\$69.99



**DeWalt DW421**  
800-433-9258  
\$79.95

But if I'm sanding a large area (or for a long period of time), a top grip is more comfortable. Since I can grip the Porter Cable, Black & Decker (B&D), DeWalt, and Makita sanders either way, they provide the best of both worlds. (See photos at right.)

**Cary:** I found the Sears and Ryobi sanders were extremely comfortable to grasp by the top. But they're fairly short. So when holding these sanders by the body, I was always worried that the sanding disc was going to slice my hand.

**Steve:** The Wen sander is the exact opposite. It's so tall that when I grab it by the top, I'm too far away from the workpiece to have much control. While the body grip is comfortable, it forces me to hold my arm parallel to the work surface which is more tiring

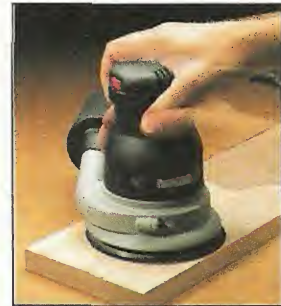

**Grip.** The top of the Ryobi (left) and the body on the Wen (center) sander provide a comfortable grip. But depending on the job, being able to grip a sander like the Porter Cable (right) either way offers more control.

if I'm doing a lot of sanding.

**Q:** What about the on/off switches on the sanders?

**Cary:** Each sander has a rocker switch. And they're all located right under the top front edge within easy reach for a right-handed or left-handed person.

But there's one thing I liked about the switches on the DeWalt, B&D, Sears, and Ryobi sanders. They have a rubber "boot" that seals out dust. And that's a definite plus for me considering the amount of dust that gets kicked up. (See photos at left.)

**Steve:** That's not such a big deal to me. In fact, compared to the positive

click you get when turning on the switches that aren't covered, they felt a bit mushy.

**Q:** I also noticed some differences in the power cords. What did you find here?

**Ken:** It's just a small thing. But I've found that the power cords that have a plastic jacket (like the ones on the Ryobi, Wen, and Makita) tend to kink and take on a "set" when you store the sander. I prefer the flexible rubber jackets on the other power cords.

**Cary:** The length of the cords is more important to me. (See margin at right.) Using a sander with a short cord is like walking a dog that yanks at the end of his leash. And searching for an extension cord is just a nuisance.



**Switches.** A "boot" that covers the switch (left) is harder to turn on and off. But unlike a standard switch (right), it seals out dust.

## Test Procedures



**Speed.** We timed how fast a sander removed material by sanding a rough board smooth.



**Scratches.** Sanding the corner of a frame showed if a sander left cross-grain scratches.



**Swirl Marks.** And swirl marks were revealed by applying stain to a board sanded up to 180-grit.

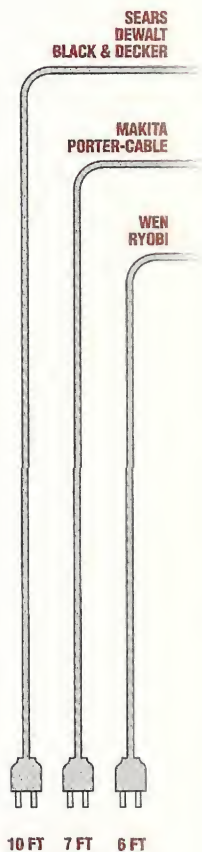

# Performance

**Q:** Let's face it. The bottom line of a sander is how well it performs. What were you looking for here? And how do these sanders stack up against each other?

**Steve:** When it comes to performance, I'm after one thing — a sander that removes stock quickly. Of all the sanders I tested, the aggressive sanding action of the Makita is what sticks in my mind. It chewed through wood twice as fast as the other sanders. (See the chart at right.)

**Cary:** Too fast for me. The Makita is so aggressive, I think it's a bit difficult to control. And that starts to wear me down if I'm working on a large project.

Besides removing stock fast, I want a sander that runs smooth — especially when I'm sanding over a long period of time.

The Porter Cable, Black & Decker, and DeWalt provided just the right combination of smoothness and speed. In fact, these sanders operated so smoothly, it surprised me how fast they knocked down the small "steps" between the boards on a glued-up panel.

**Ken:** Another thing I liked about these three sanders is they have a special brake that slows down the spinning of the pad when it's not in contact with the wood.

So even with the sander run-

ning, I can set it down on the workpiece without creating a big gouge. That speeds things up considerably when I need to check my sanding progress.

All the other sanders tend to skid when the disc first makes contact with the workpiece. So I have to turn off the sander, make sure the pad is in contact with the wood, and then start it up.

**Cary:** Even though I couldn't make a "soft landing" with the Sears and Ryobi sanders, I was still impressed with the amount of material they removed in a short time. But the vibration produced by these sanders made my hands start to tingle.

**Steve:** Not half as much as the Wen — it jumps around like a bucking bronco. In fact, the only way I could keep the sanding disc in contact with the wood was to use two hands. And even then, my hands and arms went numb after only a few minutes of sanding.

**Q:** What did that do to the quality of finish on the surface? Were there any noticeable cross-grain scratches or swirl marks?

**Ken:** Like you'd expect, the Wen left significant scratches and swirl marks. But with the

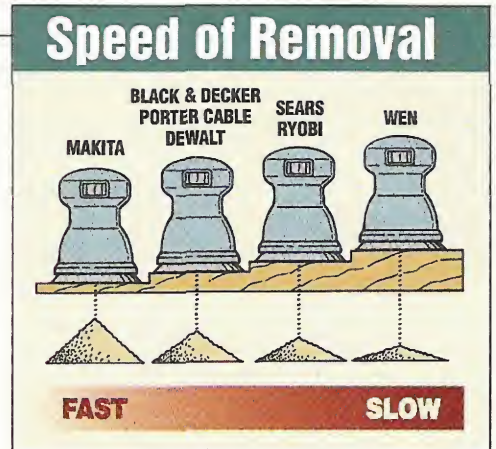

other sanders, I only noticed a few light scratches.

**Q:** Doesn't that defeat the purpose of a "random-orbit" sander?

**Steve:** I don't think so. Granted, these sanders don't leave an absolutely "swirl-free" finish. But it's nothing that a small amount of hand sanding won't quickly remove. Which is what I do anyway no matter what sander I'm using.

**Q:** Besides the basic operation of these sanders, what did you notice about the pads and the sanding discs?

**Steve:** The biggest thing is how the sanding discs attach to the pads. The Black & Decker, Sears, and Wen sanders all use pressure sensitive adhesive (PSA) discs. With these, I just peel off the protective paper backing and stick the disc to the pad.

All the other sanders have an

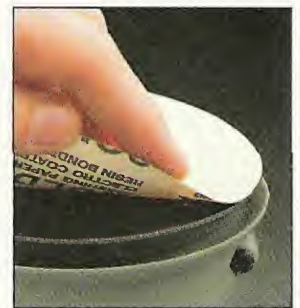
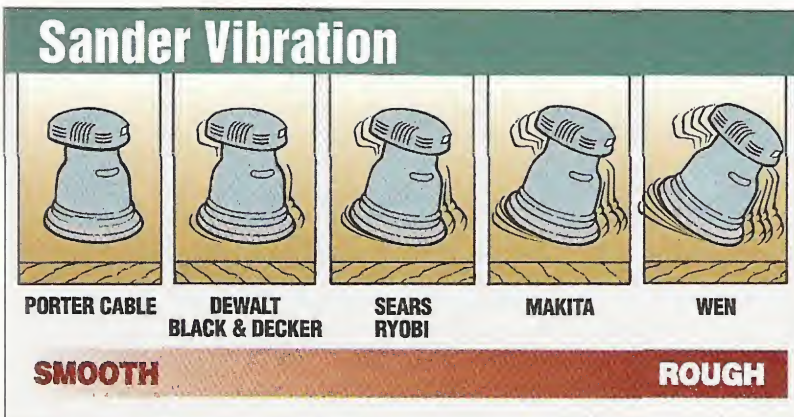

**Pads.** A hook & loop system (left) makes it quicker and easier to change sanding discs than a pad that uses pressure sensitive adhesive discs (right).

interlocking hoop and loop system. The back of one of these discs is filled with a fuzzy material that sticks to the sanding pad like a cockleburr. (See the photos on the bottom of page 14.)

**Cary:** Although the PSA discs only cost about half as much, the hook and loop systems have one definite advantage — the discs are reusable. As long as there's still some grit left, I can remove a disc and slap it back on as many times as I want.

But when I take off a PSA disc, sawdust either collects on the back so I can't attach it again, or the adhesive is just too weak to stick a second time.

**Ken:** One last thing about the PSA discs. I left one on overnight, and it nearly "welded" to the pad. The only way I could remove it was by scraping off tiny pieces of sandpaper.

**Q:** We can't talk about sanders without mentioning dust. Which sanders do the best job of controlling dust?

**Steve:** Overall, I'd have to say the hose on the Makita sander provided the best dust collection system. One end fits over a dust port on the side of the sander. (See the photos above.) And the other end attaches to a shop vacuum that draws in nearly all the dust through holes in the sanding pad.

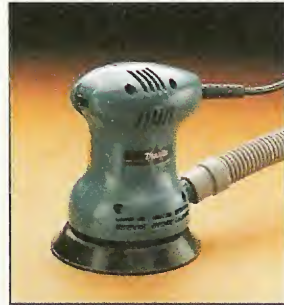

**Dust Collection.** The optional hose that connects the Makita (left) to a shop vacuum picks up nearly all the dust. But it's not as handy as the built-in canisters on the Porter Cable and DeWalt sanders (right).

**Cary:** But dealing with a hose that snakes all over the place is a pain for me. Not to mention that it costs an additional \$30 for an 8-foot hose.

**Steve:** Well at least it gives you the option of picking up the dust. With the Sears, Ryobi, and Wen sanders, there's no built-in dust collection system whatsoever.

**Ken:** That's not the case with the Porter Cable, DeWalt, and Black & Decker sanders. Each of these comes with a canister that collects dust after it's drawn up through the holes in the pad.

At first, I thought these canisters would get in my way when sanding. But when I'm working in a tight spot, the canisters can be pivoted around the body of the sander. (See the photos at right.)

**Cary:** The only problem I have with the Black & Decker and DeWalt is when I tip them over to change discs, the dust dumps out

of the canister and back into the sander. When I turn on the sander, plumes of dust blow out.

The Porter Cable gets around this with a plastic check valve that's installed between the canister and the sander. This valve opens as dust is blown into the canister. Then it drops shut to keep dust from getting back in.



**Pivot.** The dust canister on the Porter Cable can be pivoted around the body of the sander so you can sand into tight places.

## Recommendations

**Cary:** Controlling dust is important to me. So I eliminated the sanders without dust collection right off the bat. But then the decision got tough.

What finally sold me on the DeWalt is its smooth operation. Yet it still removed stock fast and gave me the best control of any sander. If I could just slap on a check valve, it would be a perfect tool.

**Steve:** I think sanding is a chore. So when it comes to picking a sander, the faster it works, the better. That's why I chose the Makita.

It's a strong running sander that "hogs" off wood. Even though that makes it a bit harder to control, it's worth it to me to get the job done quickly.

I'd even spend the extra bucks to buy the dust collection hose.

**Ken:** Since I sometimes sand for hours at a time, the Porter Cable is an easy choice.

There's almost no vibration, so fatigue doesn't become a factor. But this smoothness is deceptive. It still cuts plenty fast for any of the work I do.

And the pivoting dust canister is handy when working inside a cabinet or sanding into a corner.

# Sabre Saw Table



*Convert your sabre saw into a precision tool by mounting it upside down in this shop-built table.*

**T**ake a good tool and make it better. That's the idea behind this sabre saw table. It allows you to mount a sabre saw *upside down* under the table. Reversing the saw like this has a number of advantages over using it in a hand-held position.

First, it provides a much more stable, controlled cut. That's because you push the workpiece through the blade on a large table instead of guiding the saw on a small metal base. And second, since the blade cuts on the downstroke instead of the upstroke, the top side of the workpiece won't splinter and obscure the cut line. So it's easier to make an accurate cut.

**GUIDE SYSTEM.** But there's more to this table than just inverting your sabre saw. It also has a

unique guide system to prevent the blade from moving side to side, see photo A. So even when making a curved cut, you end up with an edge that's perfectly square to the face.

**HOLD-DOWN.** In addition to the guide system, there's a hold-down that keeps the workpiece flat against the table as you make a cut, see photo B. And for safety, a Plexiglas guard is attached to the hold-down to cover the blade.

**ADJUSTABLE ARM.** To make both the guide system and hold-down work with pieces of different thicknesses, they're supported by an adjustable arm, see photo C. This arm can be raised (or lowered) so you can cut workpieces up to 1" thick.



**A. Guide System.** To ensure a perfectly square cut, a pair of bearings prevents the blade from moving side to side.

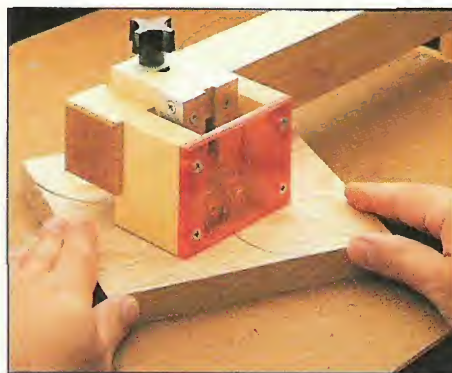

**B. Hold-Down.** A wood hold-down keeps the workpiece flat against the table. And a Plexiglas guard covers the blade.



**C. Adjustable Arm.** The arm that supports the guide system and hold-down adjusts for different thicknesses of stock.



**EXPLODED VIEW:**  
**OVERALL DIMENSIONS:**  
 15<sup>3</sup>/<sub>4</sub>"H x 26<sup>1</sup>/<sub>4</sub>" x 18"D

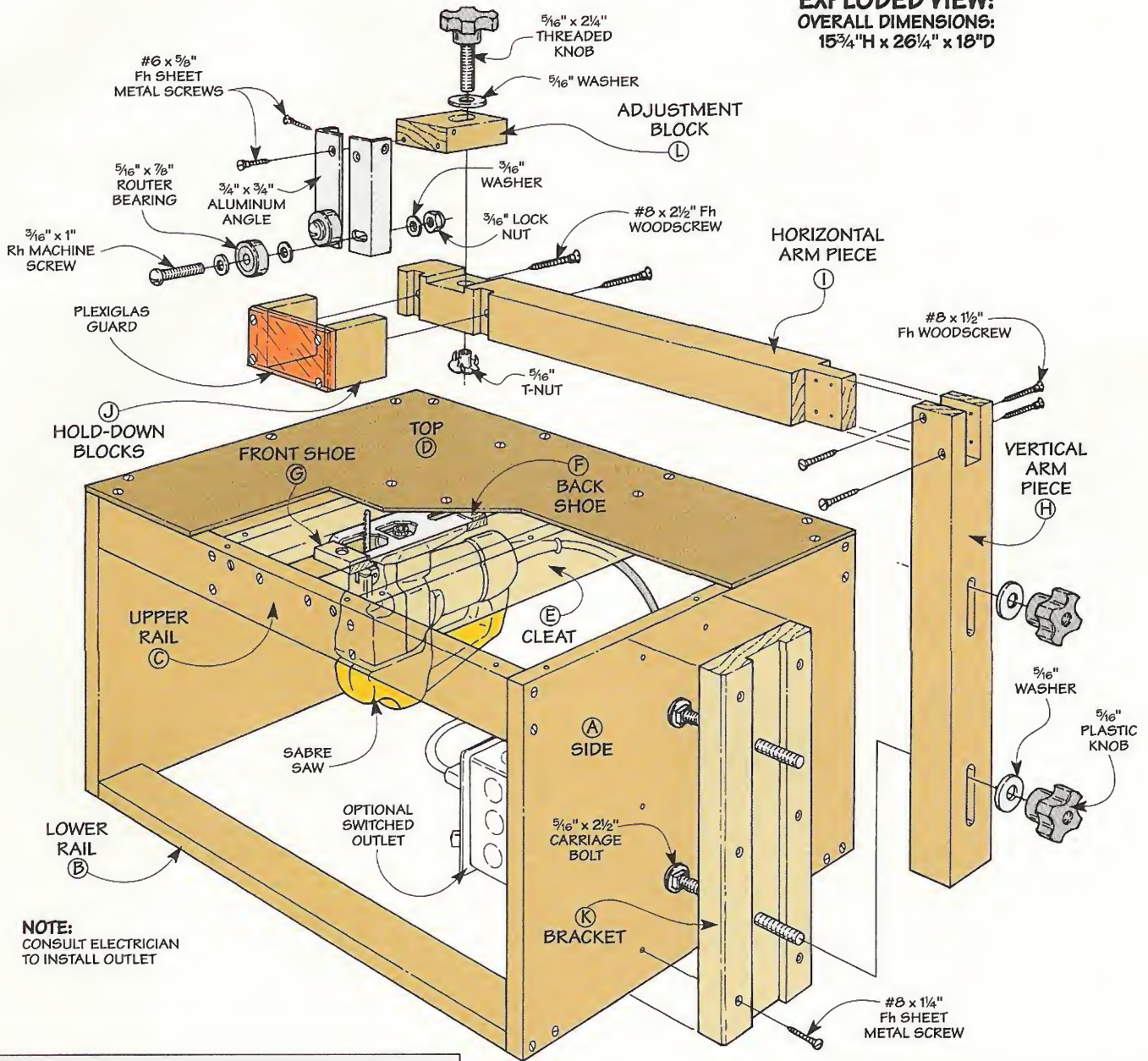

**NOTE:**  
 CONSULT ELECTRICIAN  
 TO INSTALL OUTLET

## Materials

### Base

A Sides (2)	11 <sup>3</sup> / <sub>4</sub> x 18 - 3/4 MDF
B Lower Rails (2)	2 x 22 <sup>1</sup> / <sub>2</sub> - 3/4 MDF
C Upper Rails (2)	2 x 22 <sup>1</sup> / <sub>2</sub> - 3/4 MDF
D Top (1)	18 x 24 - 1/4 Masonite
E Cleats (4)	2 x 16 <sup>1</sup> / <sub>2</sub> - 3/4 MDF
F Back Shoe (1)	3/4 x 13 <sup>5</sup> / <sub>8</sub> - 2
G Front Shoe (1)	3/4 x 13 <sup>5</sup> / <sub>8</sub> - 2

### Arm Assembly

H Vertical Arm Piece (1)	13/4 x 13/4 - 14 1/2
I Horiz. Arm Piece (1)	13/4 x 13/4 - 16 5/16
J Hold-Down Blocks (2)	3/4 x 2 - 2 1/2
K Bracket (1)	3/4 x 5 - 11 3/4
L Adjustment Block (1)	3/4 x 15/8 - 2 3/8

## Hardware

- (2) 5/16" x 2 1/2" Carriage Bolts
  - (2) 5/16" T-Nuts
  - (2) 5/16" Plastic Knobs
  - (1) 5/16" x 2 1/4" Threaded Knob
  - (3) 5/16" Washers
  - (2) 3/4" x 3/4" Alum. Angle - 3" long
  - (2) 5/16" x 7/8" Router Bearings
  - (6) 3/16" Flat Washers
  - (2) 3/16" x 1" Rh Machine Screws
  - (2) 3/16" Lock Nuts
  - (28) #6 x 5/8" Fh Screws\*
  - (6) #8 x 1/4" Fh Screws\*
  - (4) #8 x 1 1/2" Fh Woodscrews
  - (32) #8 x 2" Fh Screws\*
  - (2) #8 x 2 1/2" Fh Woodscrews
  - (2) #8 x 3/4" Fh Woodscrews
  - (1) 2 1/2" x 3 5/8" - 1/4" Plexiglas
  - (1) 5/16" x 1" Machine Screw
- \* Use flathead sheet metal screws with a straight shank
- For a complete hardware kit, call ShopNotes Project Supplies at 800-444-7002.
- Kit No. 523-6823-200.....\$19.95

# Base

I started on the sabre saw table by making the base. Basically, it consists of two parts: an open box to house the sabre saw, and a top that serves as a work surface, see Fig. 1.

**BOX.** Since I planned on painting the box, I made it from a material that has a hard, smooth surface — Medium-Density Fiberboard (MDF). But you could just as easily use plywood.

The *sides* (A) of the box are held together with two *lower* (B) and two *upper rails* (C), see Fig. 2. Although these rails are the exact same size, they're oriented differently.

To provide a solid clamping surface, each lower rail is screwed in place so its *face* will rest on the bench. And for strength, the upper rails are attached so the *edges* will support the top. Note: To avoid splitting MDF when screwing into it, see the margin at left.

**TOP.** With the box complete, the next step is to add the *top* (D), see Fig. 3. It's just a piece of 1/4" Masonite that's cut to fit flush with the outside edges of the box.

To create an opening for the saw blade, there's a short slot cut in the top, see Fig. 3a. Although

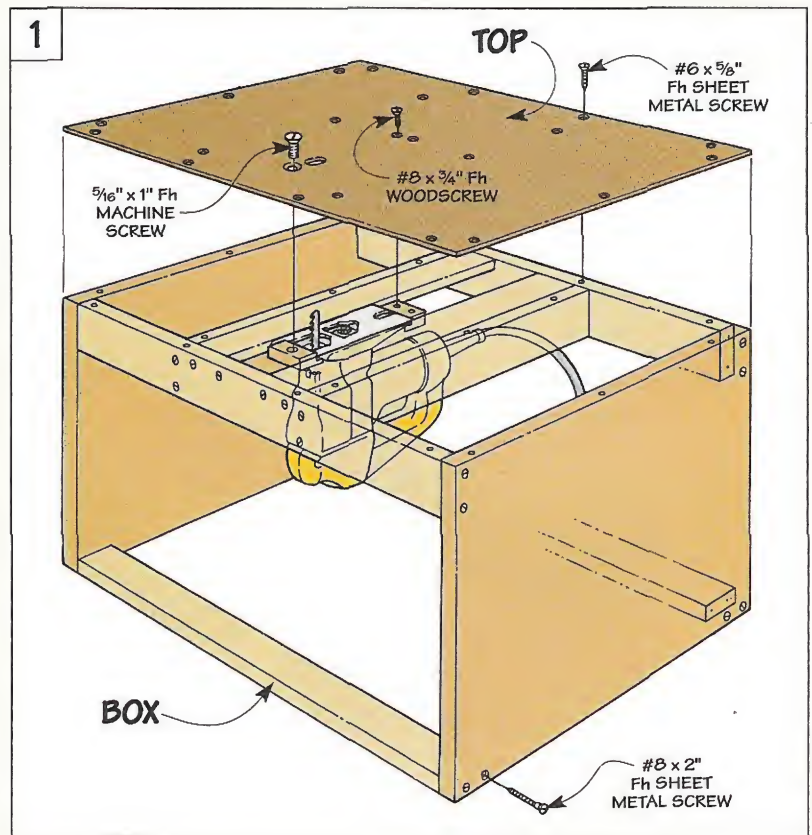

To avoid splitting MDF, drill pilot holes and use a screw with a straight shank.

this slot is centered on the length of the top, it's located closer to the front edge. This way, the body of the saw won't stick out the back of the box.

**CLEATS.** After screwing the top in place, the next step is to

add two cleats. Besides providing additional support for the top, these cleats form a pocket that accepts the metal base of the sabre saw.

Each *cleat* (E) is made by gluing up two pieces of 3/4"-thick

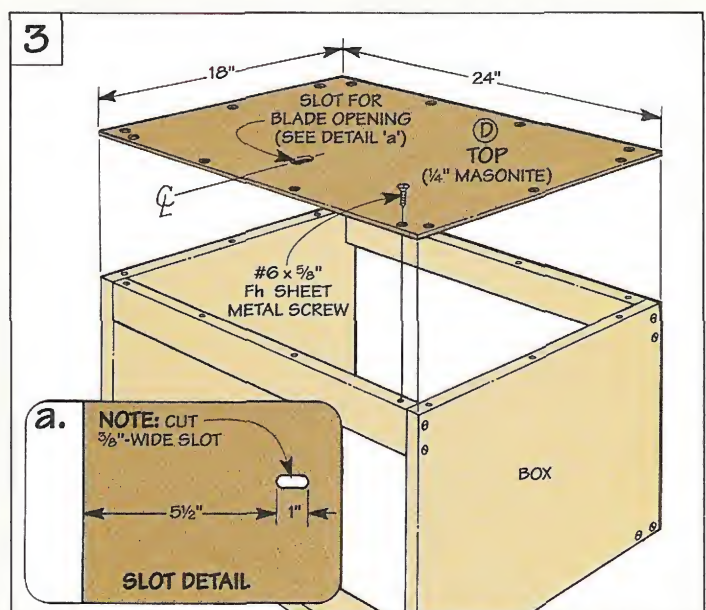
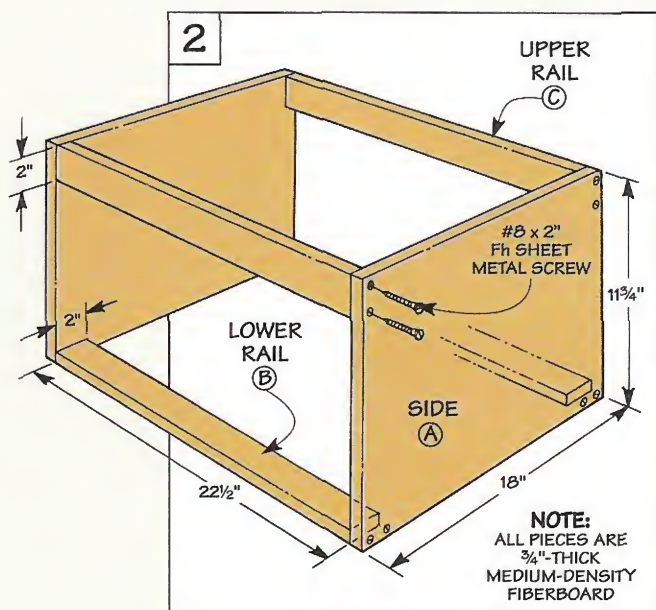

MDF into an L-shape, see Fig. 4. Once the glue dries, you'll need to use your sabre saw to determine the location of the cleats.

This is just a matter of holding the sabre saw upside down under the table with the blade centered in the slot. Then position the cleats so they fit tight against the saw base and simply screw them in place, see Fig. 4a.

**PAINT.** At this point, if you're planning to paint the box, it's easiest to remove the top. I sprayed on two coats of paint and reattached the top by screwing it to the box as well as the cleats, see Fig. 4.

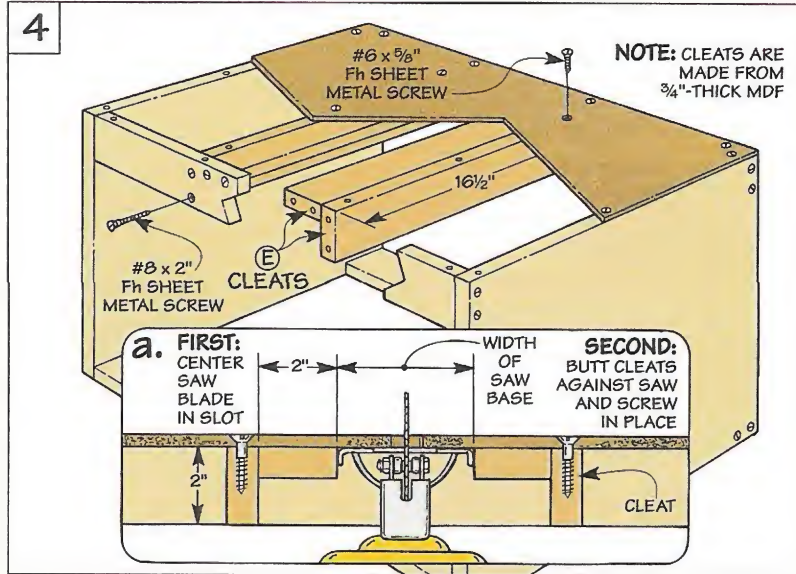

## Mounting the Saw

With the base complete, you're ready to mount the saw. While the cleats keep the saw from moving side to side, you still need a way to secure the front and back of the metal base.

To lock the saw in place (yet still make it easy to take out and use in the hand-held position), the base is held in place with two "shoes" — a back shoe that's permanently attached and a front shoe that's removable, see photo.

**BACK SHOE.** The *back shoe* (F) is a 3/4"-thick hardwood block with a rabbet cut in one edge so it fits tight over the base of the saw, see Fig. 5. Note: Depending on your saw, you may need to customize the length of the blocks and the height (depth) of the rabbets.

To attach the back shoe, the process is basically the same as with the cleats. Fit the saw between the cleats so the blade is centered in the slot, slip the shoe over the base, and screw it in place, see Fig. 5a.

**FRONT SHOE.** The *front shoe* (G) is identical to the one in the back. But to make it easy to remove the saw, it's held in place with a machine screw that threads

into a T-nut installed in the shoe.

**MOUNT SAW.** Now all that's left is to mount the saw to the table. This is just a matter of sliding the saw base under the back shoe and tightening down the front shoe to lock the saw in place.

As an option, you can attach an electrical outlet to the box that has a switch to turn the saw on and off, refer to Exploded View on page 16. Note: For questions about wiring, consult an electrician.

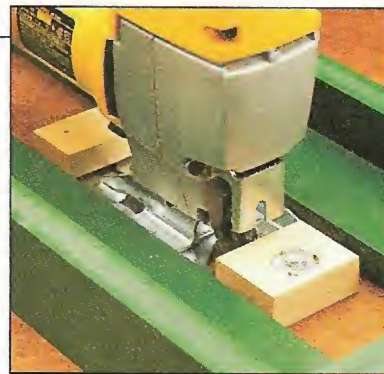

▲ In addition to cleats that keep the saw from moving side to side, two wood blocks lock it in place.

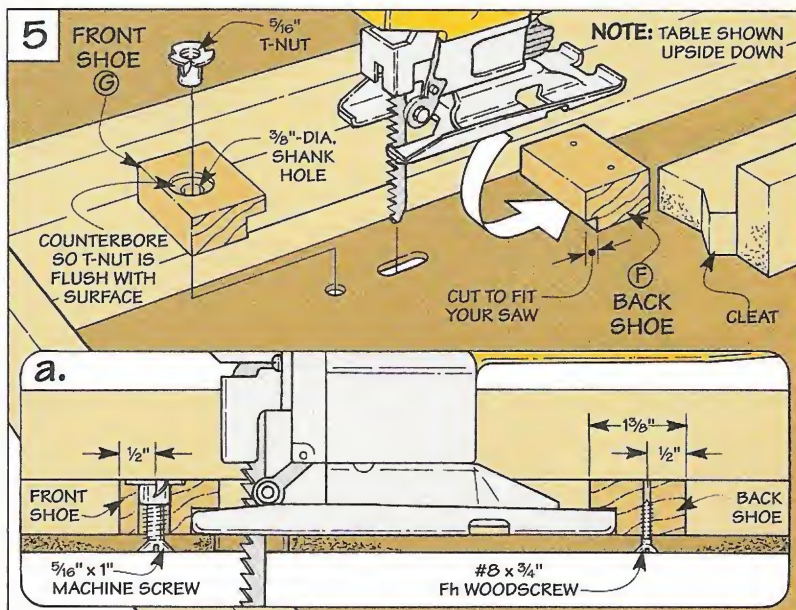

# The Arm

The unique thing about this sabre saw table is an adjustable wood arm that extends over the table. It consists of two parts: a vertical arm piece that slides up and down in a bracket, and a horizontal arm piece to support the hold-down and blade guide system, see Fig. 6.

**VERTICAL ARM.** For strength, the *vertical arm piece (H)* is made from a hardwood block (maple) that's 1 3/4" square, see Fig. 6. A pair of slots cut in this piece make the arm adjustable. And an open mortise in the top end accepts the horizontal arm, see margin.

**HORIZONTAL ARM.** Here again, the *horizontal arm piece (I)* is made from a 1 3/4"-square block. This piece has a tenon cut on the end so it fits in the mortise. But before assembling the two pieces, there are a couple things to do.

**NOTCH.** First of all, there's a notch cut in the top side of the horizontal arm for the guide system added later, see Fig. 6. A counterbored shank hole drilled in the center of this notch is used to attach the guide system, refer to Fig. 9b.

**HOLD-DOWN.** The second thing is to add the hold-down. In addition to keeping the workpiece from bouncing up and down as you make a cut, the hold-down

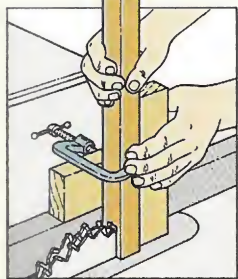
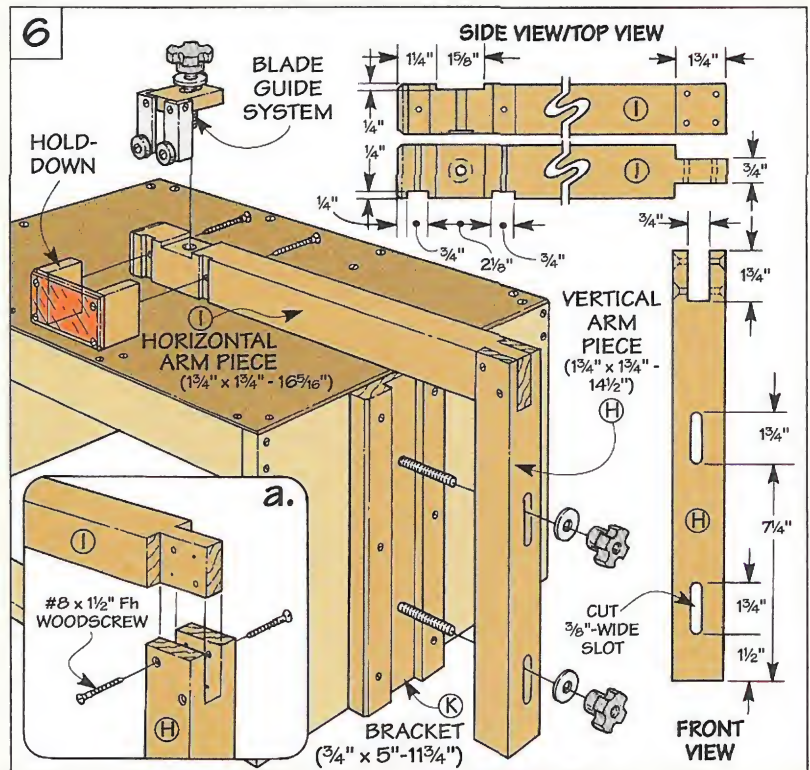

A safe way to cut an open mortise on a long workpiece is to clamp it to a support jig that's made by screwing scraps of 2x4 together.

has a Plexiglas guard attached to it that covers the exposed blade.

The hold-down consists of two 3/4"-thick hardwood blocks (J) that fit in dadoes cut near the end of the arm, see Figs. 6 and 7. It's easiest to glue and screw the blocks in place first, see Fig. 7a. Then screw the Plexiglas to the blocks.

**ASSEMBLY.** Now you can assemble the two arm pieces with

glue and screws, see Fig. 6a. Note: To prevent the screws from hitting each other, they're offset from one side to the other.

**BRACKET.** Once the arm is assembled, the next step is to add a bracket to the side of the table, see Fig. 6. In addition to holding the arm in place, the bracket tracks it straight up and down. This way, you won't have to read-

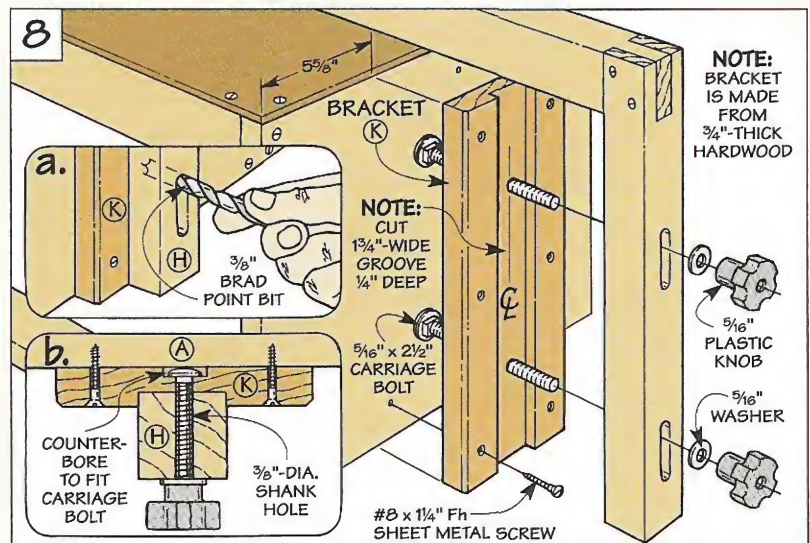
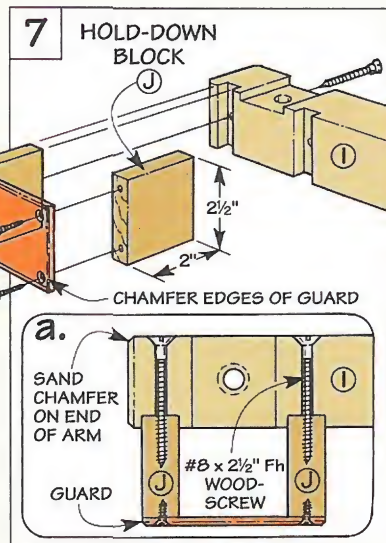

just the guide system every time you reposition the arm.

The *bracket (K)* is a piece of  $\frac{3}{4}$ "-thick hardwood with a centered groove cut in it to fit the arm, see Fig. 8. It holds the arm by means of two carriage bolts that pass through counterbored shank holes in the bracket and the slots cut in the arm, see Fig. 8b.

An easy way to locate these holes is to fit the arm into the bracket so the ends are flush at the bottom, see Fig. 8a. Then just use a brad point bit to mark through the *top* end of each slot.

After drilling the holes, you can install the bolts and fasten the arm to the bracket with washers and plastic knobs (or wing nuts). Then simply screw this assembly to the side of the table, see Figs. 8 and 8b. (For a complete hardware kit, refer to page 17.)

**GUIDE SYSTEM.** Once the arm is in place, you can add the blade guide system. To ensure a square cut, this system keeps the blade from deflecting to the side.

What makes this work is a pair of router bearings that track the blade straight up and down, see Fig. 9. (Bearings are available through woodworking stores and catalogs.) Each bearing is attached to a bracket cut from a piece of aluminum angle, see Fig. 9a.

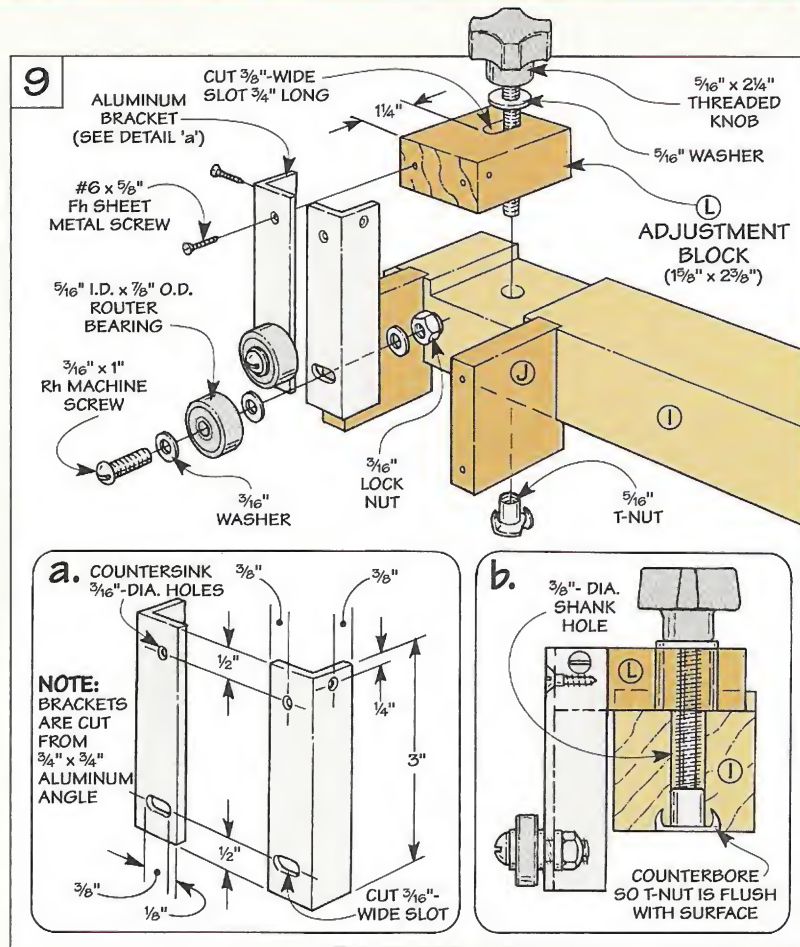

To make the bearings adjustable from side to side, there's a slot cut in each bracket. And an ordinary wood block allows you to adjust them front to back.

This *adjustment block (L)* is a scrap of  $\frac{3}{4}$ "-thick hardwood with a slot cut in it. After screwing a

bracket to each corner of the block, it's attached to the arm with a threaded knob and T-nut.

**ASSEMBLY.** All that's left is to install the bearings. To allow them to spin freely, they're held in place with a machine screw, three washers, and a lock nut, see Fig. 9b.

## Adjusting The Guide

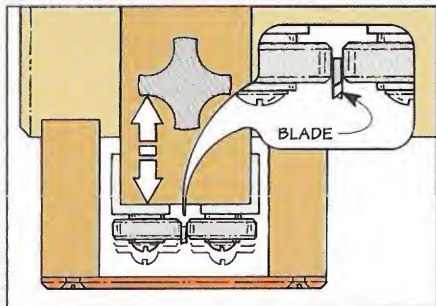

**Step 1.** Slide the adjustment block forward (or back) so the bearings are right behind the teeth on the saw.

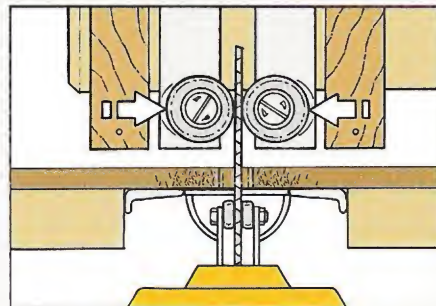

**Step 2.** Now remove the guard and position the bearings close to (but not touching) the saw blade.

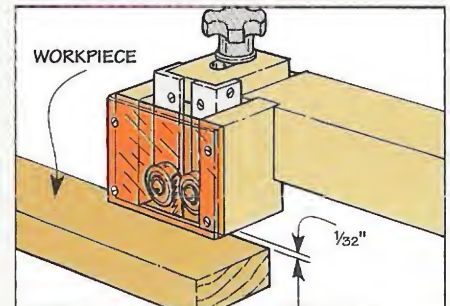

**Step 3.** Finally, adjust the arm so the hold-down is about  $\frac{1}{32}$ " above the workpiece and lock it in place.

# Dowel Joinery



**T**he first type of joinery many woodworkers are introduced to is the dowel joint. It's easy to make and surprisingly strong.

Yet, as woodworkers gain experience, they tend to "outgrow" dowel joinery. That's too bad. It's still a simple, effective way to join two pieces of wood.

One of the nice things about dowel joinery is you don't need much equipment. All it takes are dowel pins, a hand drill, and some simple shop-made jigs to ensure that the holes align.

**DOWEL PINS.** There are two common dowel pins: fluted and spiral, see photo above. Mechanically,

they both do the same job.

I prefer fluted dowel pins because they hold glue the best. And they allow air inside the hole to escape better, making assembly go easier. In any case, I don't recommend short lengths of common dowels. They tend to trap air and do a poor job of holding glue.

## Frame Joint



■ To join frame pieces together with dowel pins, the holes must be parallel and align perfectly.

The simplest way I've found to ensure this is to use a shop-made doweling jig, see drawing at

right. It's just a piece of  $\frac{1}{4}$ " Masonite screwed to a block of hard maple. Two holes in the block help keep the opposing holes parallel and aligned. Alignment marks on the Masonite allow you to precisely position the jig on each piece.

To use the doweling jig, first draw a layout line across the center of the joint line, see Fig. 1. Then clamp the jig to one of the workpieces — with the jig's alignment mark centered directly on the layout line, see Fig. 2.

After drilling the first set of holes with a brad point bit, clamp

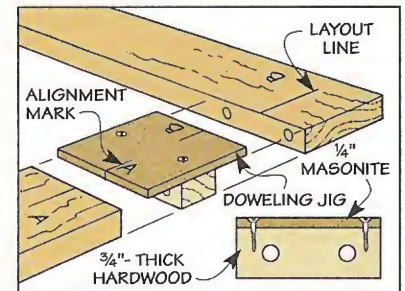

the jig to the other workpiece in the same manner. Then drill the opposing set of holes — through the opposite end of the jig to ensure the holes are parallel and aligned, see Fig. 3.

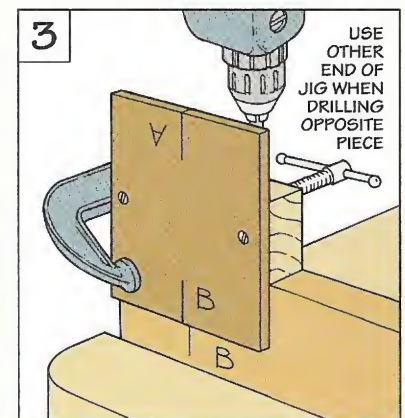
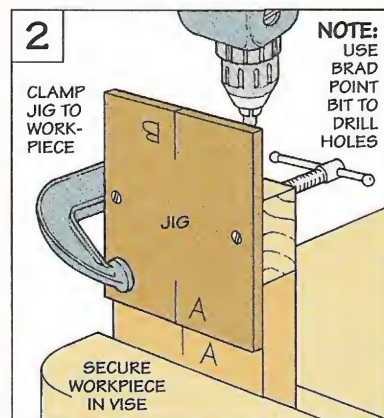
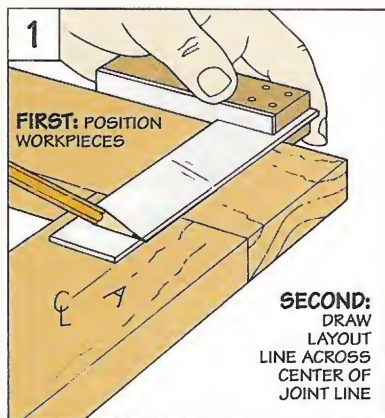

# Butt Joint

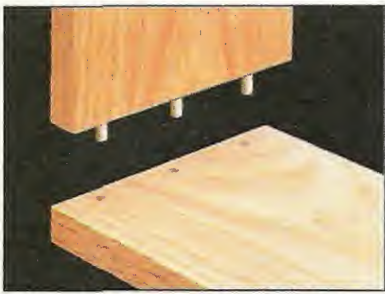

■ When using dowels to join wide boards or panels, I use an alignment block, see drawing at right. It's just a piece of hard maple cut to match the parts being joined.

The length of the block equals the width of the stock. To keep your drill bit straight, the jig should be at least 1" tall (wide). And to make it easy to align the jig on the workpiece, its width should equal the thickness of the stock, refer to Fig. 2.

To use the jig, first arrange your workpieces and mark their centers, see Fig. 1. Now clamp the jig on the end of the first workpiece, see Fig. 2.

Once holes are drilled, the jig can be moved to the face of the

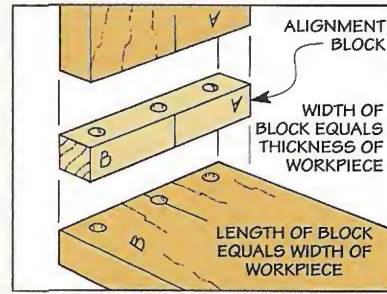

adjoining workpiece, see Fig. 3. To end up with opposing holes, position the jig on the other workpiece — making sure not to flip it end-for-end or side-to-side.



To quickly coat a hole with glue, stir the glue around with a dowel.

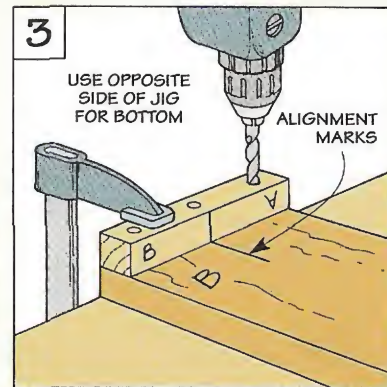
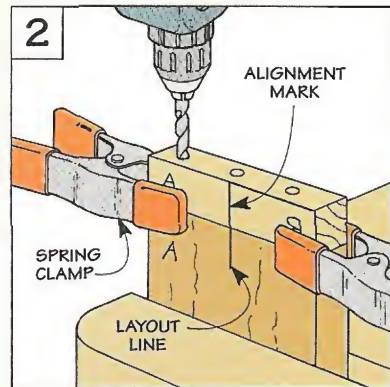
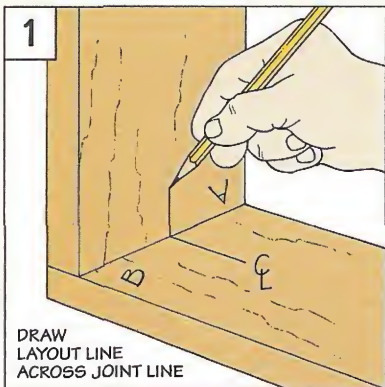

# Edge Joint

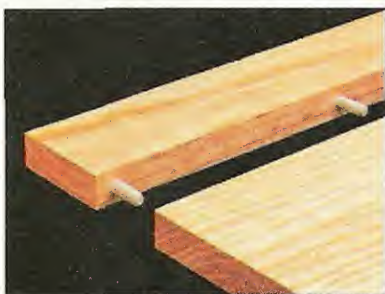

■ Although dowels don't add strength to an edge-glued joint line, they are useful for aligning slippery boards during clamping.

To drill straight holes into the edge of a board, I use the drill press and a fence, see Fig. 1. Then dowel centers are used to locate the opposing hole in the adjoining

workpiece, see Fig. 2 and photo.

Finally, to ensure the second set of holes are drilled to align with the first set, make sure that you reference the same facing side of the board against the drill press fence that was referenced on the first board.

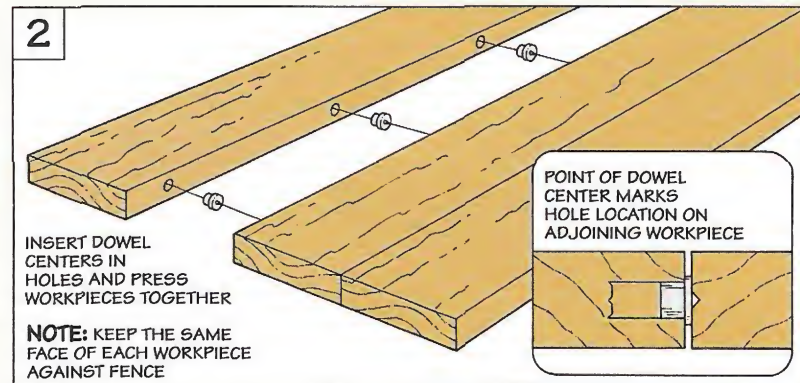
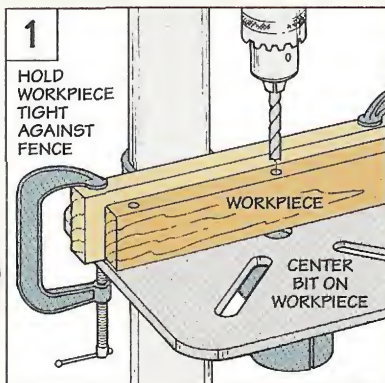

# Lumber Storage Tips

*Here are three storage ideas to help you organize and store short lengths of lumber and sheets of plywood.*

## Lumber Bin

■ Storing and organizing shorter lengths of lumber is always a problem. Lumber like this is generally too short for a rack and too good to throw out. To store short lengths of lumber, I use this free-standing lumber bin, see photo.

It works much the same way as an album rack in a record store. It

has six different bins for sorting wood by size and species. And it's sloped from back to front to make it easy for you to flip through each board — like you would a bin full of albums. (Remember those?)

The lumber bin can be built from two sheets of 1/2" plywood, see drawing. It consists of two

individual units (three bins each) screwed together in the middle.

To make assembly easy, each unit's sides and dividers are cut to the same dimensions. The fronts and backs are the same length.

Once the sides and dividers are screwed to the bottom, the front and back are cut to fit each unit.

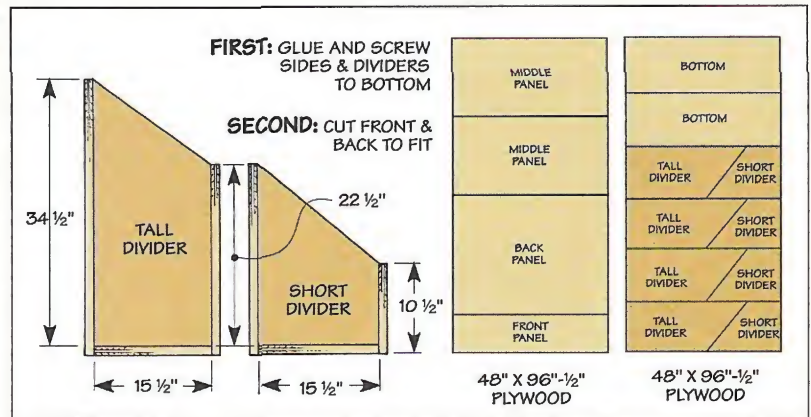

## Lumber Rack

■ If you don't have the floor space for a lumber bin like the one shown above, another way to store short lengths of lumber is to use this double-sided, overhead lumber rack, see drawing.

It's a simple design that doesn't require any special joinery. All you need are a couple of exposed joists in your ceiling, a few 2x4s, and a handful of 4" carriage bolts.

Each rack is made up of a support bracket with two oversized arms. And the arms are tapered slightly to help keep the lumber in place.

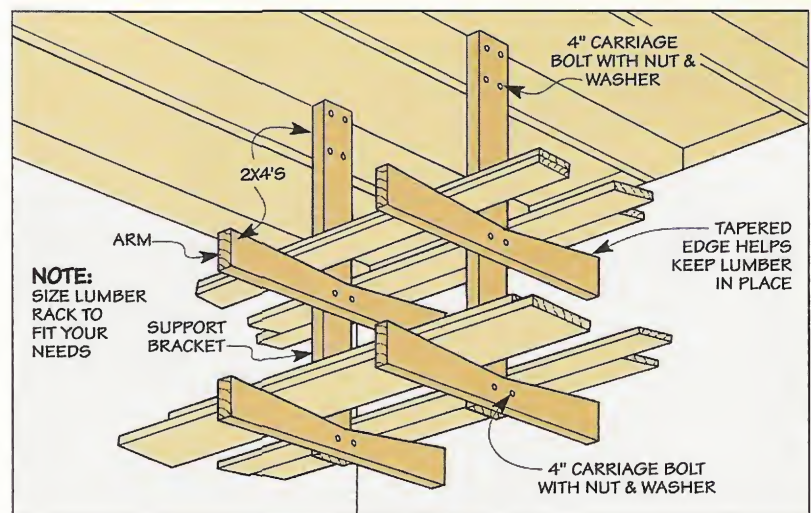



# Plywood Storage Bracket

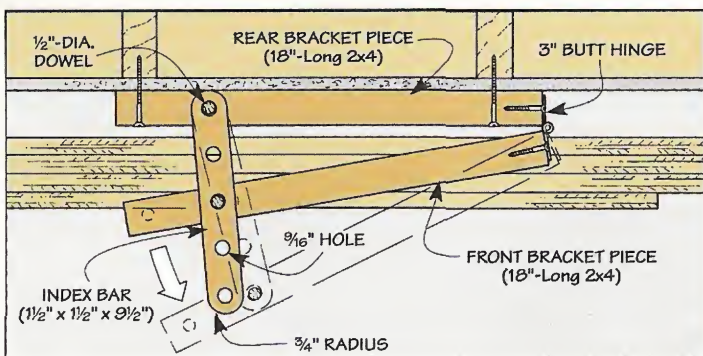

■ Storing plywood and other sheet goods doesn't require an over-sized shelf or a large lean-to storage rack. All it takes is some free wall space and this simple wall bracket, see photo.

The wall bracket consists of two parts: a hinged bracket attached to the wall holds the plywood in place, and an index bar adjusts the opening of the bracket to allow for varying amounts of sheet goods.

The hinged bracket is just two 2x4s joined together at one end with a 3" butt hinge, see drawing. And a 1/2" dowel glued into the top of each 2x4.

These dowels fit in holes drilled into the index bar so you can adjust the front bracket piece. The plywood is held against the wall with another 1/2" dowel (8" long) that's glued into the *bottom* of the front bracket.

I ripped the index bar to width

from a short length of 2x4. Once it's cut to size, the holes can be drilled. Then a radius is cut at each end to soften the sharp corners and allow the index bar to clear the wall.

To use the storage bracket, select a hole in the index bar that takes the most slack out of the front bracket. When you want to sort through the stack, just lift off the index bar from the dowels and set it on the last hole.

# Transporting Plywood

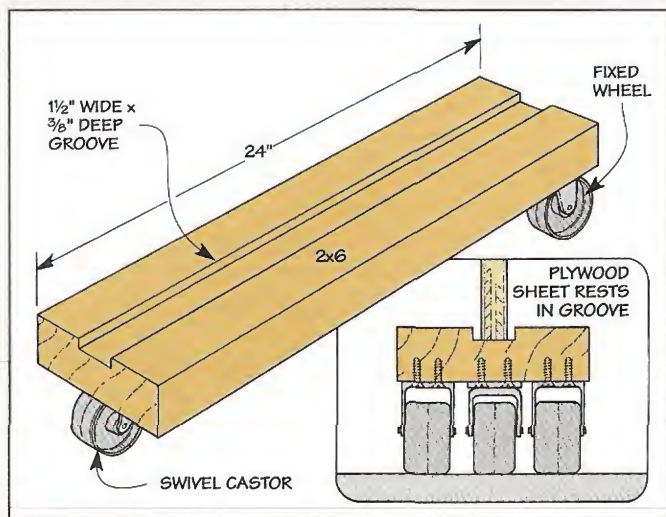

**Dolly.** The easiest way I know to move sheet goods around the shop is with this dolly. The dolly is just a short length of 2x6 with three wheels. Two wheels are fixed. The third is a swivel castor that allows the dolly to be steered around the shop. To keep a sheet of plywood from slipping off the dolly, a groove is cut down the center of the 2x6 before the wheels are attached.

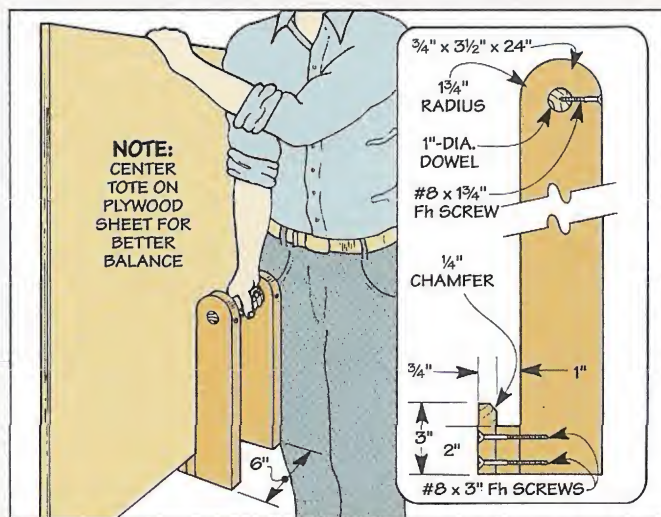

**Tote.** When I need to lift a sheet of plywood, and there's no one around to give me a hand, I use this "handy" tote. It's designed to hook under the bottom edge of the plywood. The round handle is easier on my hand than the sharp edges of the plywood. And the extended sides on the tote make it possible for me to pick up a heavy sheet with my legs — rather than my back.

# Varnish

*A deep, formal looking finish. And a tough, durable film. Two reasons why varnish is ideal for your special projects.*

**A** special finish for a special project. That's how I look at varnish. It produces a deep, formal looking finish. And it's one of the toughest, most durable finishes you can apply.

But not all varnishes are the same. Depending on the mix of solids and solvents, some types will act differently when you brush them on. So it's especially important to test the varnish on a scrap piece before applying it to your heirloom project.

**PORE FILLER.** Besides getting a feel for the working qualities of the varnish, you also need to decide between a glass smooth finish and one that shows the texture of the wood. For a mirror finish, fill the pores of the wood with filler *before* applying the varnish.

**APPLICATION.** The key to applying varnish is simple — patience. That's because it dries very slowly. As a result, you need to be on the lookout for a couple of things.

**DUST.** First, the wet film acts as a magnet for dust. To minimize the amount of dust that settles in

the finish, sweep the shop and wait until the dust settles before applying the finish. Then wipe the project with a tack cloth.

But even with a careful cleaning, you can still pick up dust with the brush. To avoid contaminating the finish in the can, pour only the amount of varnish you need into a separate container.

**RUNS & SAGS.** Because it dries slowly, varnish also has a tendency to run or sag — especially on vertical surfaces. So if possible, position the project so the surface you're working on is horizontal. Also, a simple brushing technique can keep most problems from cropping up, see box below.

**FIRST COAT.** Depending on the brand of varnish, you may need to thin down the first coat with mineral spirits. Or, some manufacturers recommend applying it full strength. In either case, once the varnish cures, you'll need to sand it to prepare for the next coat.

A rubber sanding block with 320-grit wet/dry silicon carbide sandpaper works well here.



**Shop Tip:** Sprinkle just a small amount of soapy water on the surface to keep the sandpaper from clogging.

To avoid cutting through the finish, the important thing is to check your progress frequently. This means you'll need to wipe the surface dry.

What you want is a dull, uniform sheen. (A low spot will show up as a shiny streak.) If it looks like you'll have to cut through the finish to remove all the shiny places, stop sanding and use the next coat to fill in the low spots.

**ADDITIONAL COATS.** To build up a protective film, you'll need to apply several additional coats of varnish, sanding between each coat. If you're after a satin finish, two or three coats usually provide plenty of protection. But if you plan to rub out the finish to a glossy sheen, you may need to apply as many as five or six coats.

## Brushing Tips

Getting a professional-looking finish with varnish starts with a good-quality natural bristle brush. (I use a badger-hair brush.) It loads well without dripping. And it releases the varnish evenly.

To avoid introducing air bubbles into the finish, the key is to use gentle pressure and draw the brush *slowly* across the workpiece, see photo A.

Then, once the surface is covered, tip off the finish to remove any brush marks, see photo B.



**A. Flow On.** Hold the brush at about a 45° angle to the workpiece and flow on a heavy coat of varnish.



**B. Tip Off.** Now hold the brush upright and use the tips of the bristles to remove any brush marks.

# New Products

*Here's a look at three new products that have found a place in our shop.*

## Fractional Calculator

■ Quick, what's  $\frac{1}{4} + \frac{3}{16} + 3\frac{5}{8} - \frac{1}{2}$ ? I don't know about you, but I can't quickly add fractions like these in my head. So when I came across this solar powered *Tape Mate* by *DigiTool*, I knew we had to get one for the shop.

The *Tape Mate* is great for adding and subtracting fractions. You can also use it to figure things like the even spacing of five shelves in a 54"-tall cabinet.

Or how many spindles you'll need for a 36"-long cradle, with the spindles spaced every  $3\frac{1}{2}$ ".

This handy tool slips over your tape measure. Or you can take it out of its protective case and carry it in your shirt pocket.

The *Tape Mate* costs around \$25 and is available through hardware stores and home improvement stores. Or you can order directly from *DigiTool*.



Source:  
• *DigiTool*  
800-543-8930

## Customized Knobs

■ Every now and then a piece of hardware catches my eye. For instance, these brass knobs by *Veritas* are open ended so you can plug them with wood to match your project. (Or use contrasting wood if you want them to stand out from the project.)

To customize a knob, simply epoxy a wood plug in the recessed area of the knob. Then thread it on a mandrel (available from

*Veritas*) and chuck the knob in a lathe or drill press. Now it's just a matter of turning or sanding the plug smooth until it's flush with the rim of the knob.

Brass insert knobs come in three different sizes:  $\frac{1}{4}$ " (\$2.25 each),  $\frac{3}{8}$ " (\$2.60), and  $\frac{5}{8}$ " (\$2.95). The insert knobs and mandrel (\$1.50) come with complete instructions — they're all available through *Veritas*.

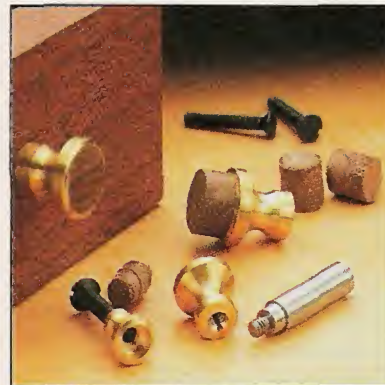

Source:  
• *Veritas Tools, Inc.*  
800-667-2986

## Collapsible Square

■ The first time I came across a *Nobex Quattro* square, I thought it was just another try square — only good for 90°. But when I picked one up, I realized it also adjusted to two additional angles, 45° and 135°.

And when not in use, the blade folds up into the base like a blade in a pocket knife — which makes it easy to slip it into the pocket of your shop apron or in your tool box.

But what amazed me most about this square is how solidly it "locks" in the different positions. The secret to its accuracy is a set of ball bearings used to snap and lock the blade in place.

The *Nobex Quattro* is available with either a 6" or 10" blade. Both are available through many mail-order woodworking catalogs in a price range of \$17 to \$20. Or from *Farris Machinery*.

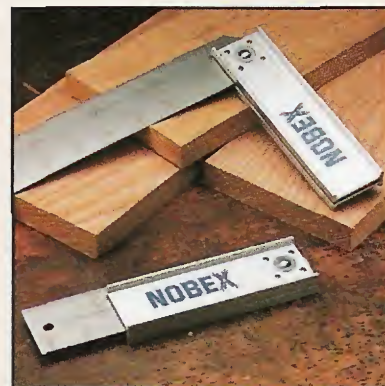

Source:  
• *Farris Machinery*  
800-872-5489

# Shop Solutions

## Dado Blade Jig

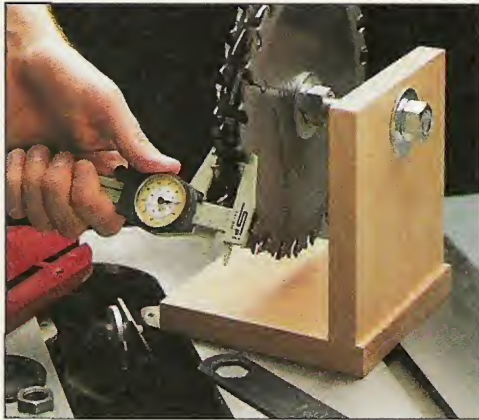

■ Setting up a dado blade can be a chore. So rather than mount it in my saw and then add or remove chippers and shims, I use a simple set-up jig, see photo.

The jig is just an L-shaped wood stand, see drawing. By making it free-standing, I can use a dial caliper or rule to check the blade's width. And when I'm not using the blade, I store it on the stand.

*Charles R. Smith  
Sharon, Ontario*

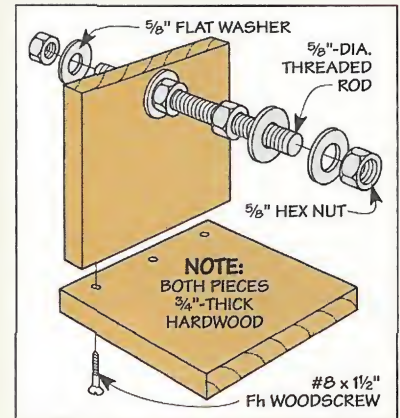

## Two-Sided Clamp Storage

■ I built the Clamp Storage System shown in *ShopNotes* No. 19 with one modification. Rather than screw the pegboard rack directly to the wall, I made a frame with hinges for it to hang from so it could swing out from the wall.

This allows me to take better advantage of the wall space in my shop by using the back of the rack for additional clamp and tool storage, see drawing.

The frame is made from standard construction grade 2x6s I picked up from a local lumberyard. I mounted them on edge with extra-long lag screws so the frame would be deep enough for the tools hanging on the back.

To help support the extra weight the tools added and make it easier for me to swing the rack, I installed a 3" caster to the bottom of the pegboard rack before screwing it to the hinges.

Finally, to keep the pegboard against the wall when not in use, a small hook and eye are screwed into the frame and pegboard to keep it closed.

*Ben Lund  
Johnston, Iowa*

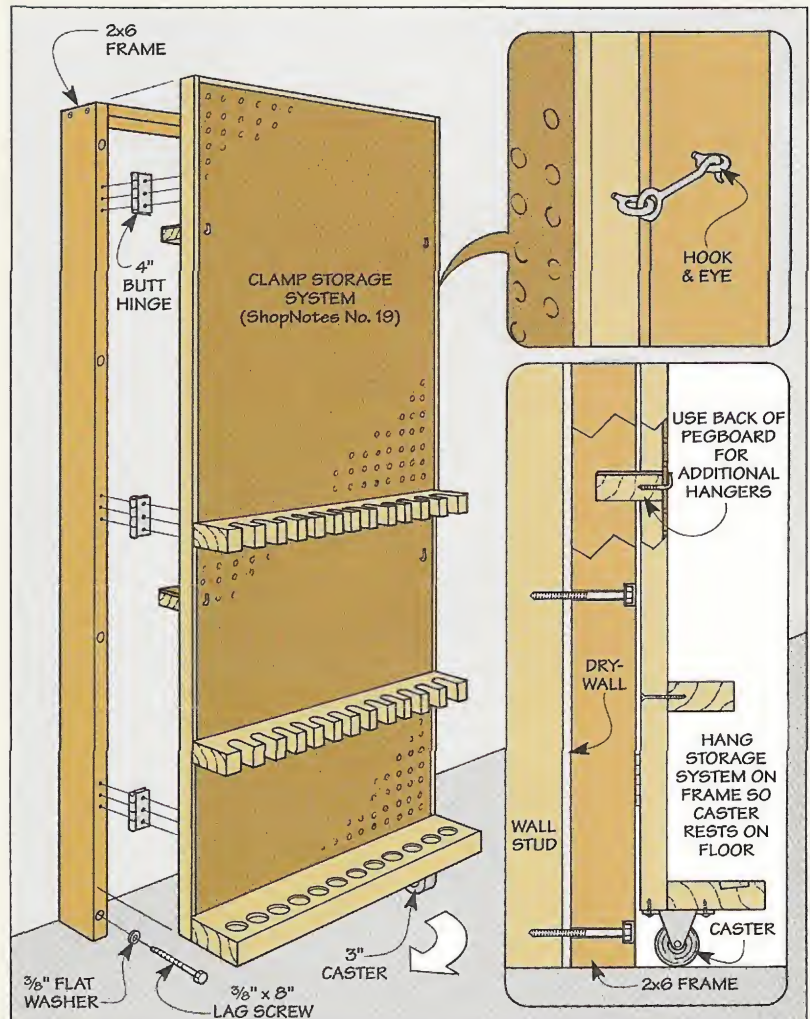

## Collet Wrenches

■ Like many routers, my router requires two wrenches to loosen and tighten the collet. One prevents the spindle from turning; the other turns the collet nut.

To avoid over-tightening the collet and prevent my knuckles from rapping together when the nuts break free, I only use *one hand* to handle both wrenches when tightening and loosening the collet, see photos at right.

*James A. Norton  
Humboldt, Saskatchewan*



**Tighten Collet.** A single grip and a squeeze are all it takes to tighten a bit in a collet nut.



**Loosen Collet.** To loosen a collet, reposition the wrenches and just squeeze them together.

## Plywood & Lumber Rack

■ *ShopNotes* No. 20 featured an overhead lumber rack. But rather than build it as described, I modified its length to include an extra arm for additional lumber storage and a platform for holding plywood, see drawing.

To accommodate the extra arm and platform, I extended the support bracket from the ceiling joist to the floor. Then added a 2x4 base, see detail.

Once each lumber rack was bolted to the joists, I added two pieces of  $\frac{3}{4}$ " plywood to form an L-shaped platform, see detail. This allows the plywood to slide smoothly without catching on the support brackets or base pieces.

*Dan Howett  
Cincinnati, Ohio*

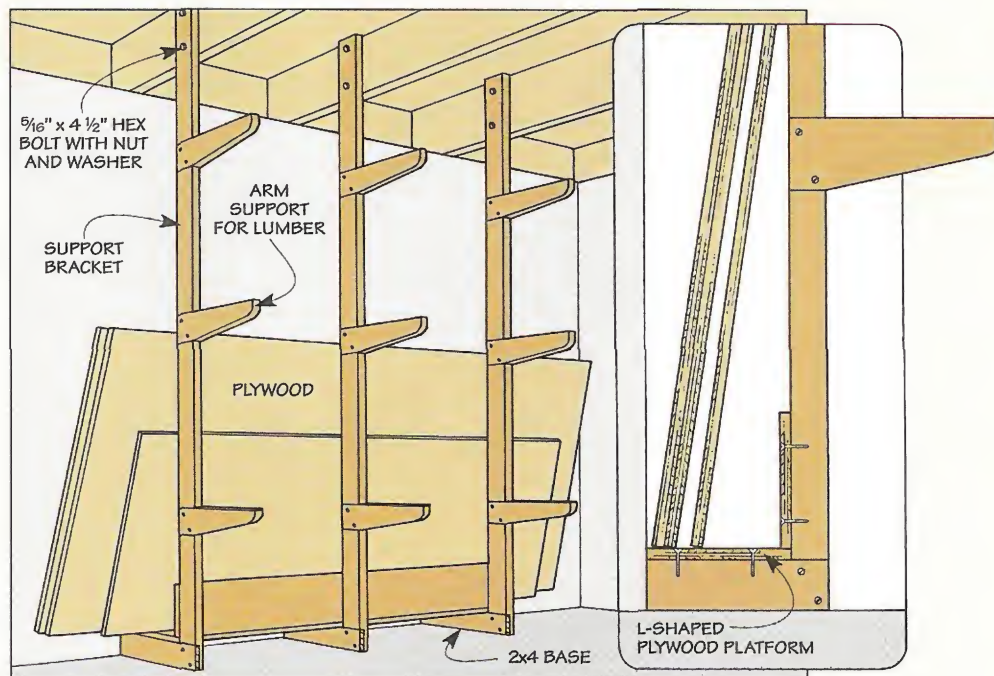

## Quick Tips

■ To extend my pipe clamps, I couple them to lengths of threaded pipe using pipe couplers. To protect the threaded ends of the clamps and pipes when they're not in use, I cap the ends with rubber chair leg tips. Leg tips are available in various sizes at hardware stores for around 50¢ each.

*Michael J. Hoag  
Endicott, New York*

■ In *ShopNotes* No. 20, you mentioned a technique using lacquer thinner to release plastic laminate from contact cement. I use a heat gun. It's not as quick, but it's certainly not as messy. Just sweep the heat gun across the laminate until the glue heats up enough to allow you to peel off the laminate.

*John Huntington  
Uxbridge, Massachusetts*

### Send in Your Solutions

If you'd like to share your original solutions to problems you've faced, send them to: *ShopNotes*, Attn.: Shop Solutions, 2200 Grand Avenue, Des Moines, IA 50312. (Or if it's easier, FAX them to us at: 515-282-6741.)

We'll pay up to \$200 depending on the published length. Please include a daytime phone number so we can call you if we have any questions.

# Buying Lumber

*I'm new to woodworking and was wondering if there are any tricks to buying hardwood lumber? I'm not sure how much extra to buy for a project or what to look for.*

*Alex Serpico  
Beech Grove, Indiana*

■ I think the biggest trick to buying hardwood is to take your time. A friend of mine says the process I use to select hardwood is like a beauty pageant — except the contestants are pieces of lumber. For the preliminary round, each piece is quickly judged for color, grain, and lack of warp, see photos below. The best of these are set aside as semifinalists.

Then the semifinalists are looked over carefully. Here, each piece is scrutinized for sapwood, knots, stain, checks, snipe, and chipout, see photos on opposite page. This helps bring the board count down even further. Finally,

I make my final selections based on color match and grain pattern.

Although this sounds like a lot of work, it's not. And besides, I enjoy rummaging through lumber. Who knows what I'll find? The guys at the lumber store know I'll go through the entire stack, but they *don't* mind. They know I'll carefully restack the lumber after I'm done sorting.

There's nothing wrong with being finicky about lumber. It'll pay off in the long run — you'll see it in your finished project.

## PRELIMINARY ROUND

As you begin to make your way through a stack of lumber, it's not necessary for you to spend a lot of time looking over each board. A quick glance at each face and edge is all it takes.

**CROOK & WARP.** The first two things I judge a board for are crook and warp. If a board isn't

straight and flat, I quickly pass on it and pick up the next board.

As you look over each board, take a quick glance at both faces for their general appearance. Then sight down one edge to see how straight the board is. If it's crooked or bowed move on to the next board.

If the board is straight, site down its length along one face to check for cup or twist. If the board is flat, then check the general appearance of the color and the grain. If they're both reasonably good, set the board aside for later consideration.

## SEMIFINALISTS

Now you can begin to narrow down the field. As you shuffle through your good stack, pay particular attention to sapwood and take any boards with sapwood out of the running.

This can be a challenge, though,

*Taking the time to sort through a stack of lumber will pay off in the long run.*

Take your time to carefully sort for the boards with the best color match, especially when sorting through cherry.



Lumber with wild grain tends to be harder to work with and more difficult to finish than lumber with straight grain.



Lumber with a bow or cup should be avoided — unless a flat section of the board has a perfect grain or color match.



## Tips for Buying Lumber

- 1 The first step to buying hardwood lumber is to quickly sort for the flattest, straightest, and nicest-looking boards.
- 2 Once you have about twice the amount of lumber you'll actually need, check the stack for boards containing sapwood.
- 3 When shuffling through your stack, also sort carefully for knots, stain, checks, snipe, and chipout.
- 4 After the field has been narrowed, compare each board to the others and select those with the best color match.
- 5 If you still have more lumber than you'll need, sort the stack one more time for the boards with the straightest grain.
- 6 After making your final selections, tally up the board footage with a lumber scale to make sure you have enough lumber.

when sorting through freshly milled lumber (such as cherry, walnut, and ash) — it's often difficult to distinguish sapwood from heartwood. So take the time to carefully inspect each board.

As you sort for sapwood, it's also a good time to look for knots, stains, checks, snipe, and chipout. Compare each board to the others and keep those that look the best.

### FINALISTS

Now comes the hard part. Deciding on which boards go to the shop. Here, it might only come down to knowing how many board feet of lumber your project calls for and figuring out which boards total up to that amount (for more this see box below).

Note: Whenever I buy lumber for a project, I always get 15% to 20% more than what the project calls for. The extra wood allows me to do a couple of things.

First it provides room for waste and an occasional mistake. And second, it gives me more freedom as I'm building a project to sort out pieces that don't



**Appearance.** When sorting through a stack of lumber, a quick glance at both sides of each board is all the time you need to spend to eliminate any boards with sapwood (left), knots (center), or stain (right).

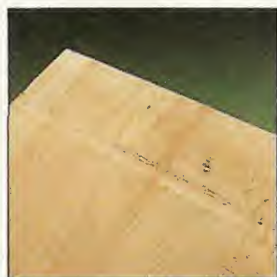

**Physical Defects.** Lumber with physical defects such as checking (left), planer snipe (center), and chipout (right) can be used. But if there are other boards to pick from, I'll generally pass on those with these defects.

match the rest of the project.

If you have more lumber in front of you than needed, compare the color and grain patterns of each board one more time.

Those with the best color match are my first picks. If I still have too much lumber, I select the boards with the straightest grain and head for the cash register.

## Using a Lumber Scale

A lumber scale is similar to a slide rule — except there are no moving parts. The information needed to determine board footage is imprinted on the scale. You don't need a calculator, a pencil, or a piece of paper. All you need is to know how to read it.

One end of a lumber scale has a reference point that all readings are taken from. On most, three graduated scales are imprinted on each side. These six scales allow you to measure the board footage of the six most common lengths of  $\frac{1}{4}$  lumber.

To use a lumber scale, just lay it across the width of a board and read

the scale that corresponds to the board's length. When measuring  $\frac{3}{4}$  lumber, just double the reading. And if you're measuring a board there's no scale for, double the length of the board, use the appropriate scale, and then divide the reading in half.

The lumber scale I use (\$35) has half board feet increments, see photo at right. When taking a reading, I round up (or down) to the nearest quarter board foot. And according to the National Hardwood Association, if a board is tapered, lay the scale across it at one third the distance from the widest end.



**Lumber Scale.** A lumber scale allows you to quickly figure board footage. For your nearest dealer call the Conway-Cleveland Corporation (616-458-0056).

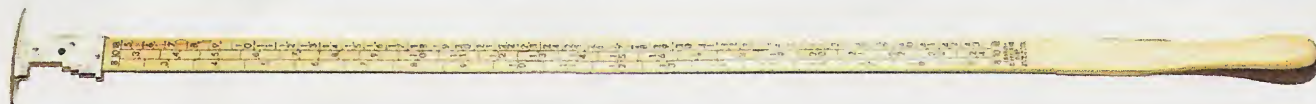

## Scenes from the Shop



▲ Selecting a palm-grip random-orbit sander can be a challenge. Our team of woodworkers tests seven models and offers suggestions on what to look for.



▲ This shop-made blade storage cabinet organizes your saw blades and keeps them right at hand. At the same time, it protects the blades from being damaged.



▲ Let the chips fly. Spend an enjoyable afternoon in the shop turning this sturdy carver's mallet on your lathe.

Its simple design allows you to complete it with just two basic tools — a spindle gouge and a parting tool.