

TIPS • TOOLS • TECHNIQUES

ShopNotes®

Vol. 4

Issue 24

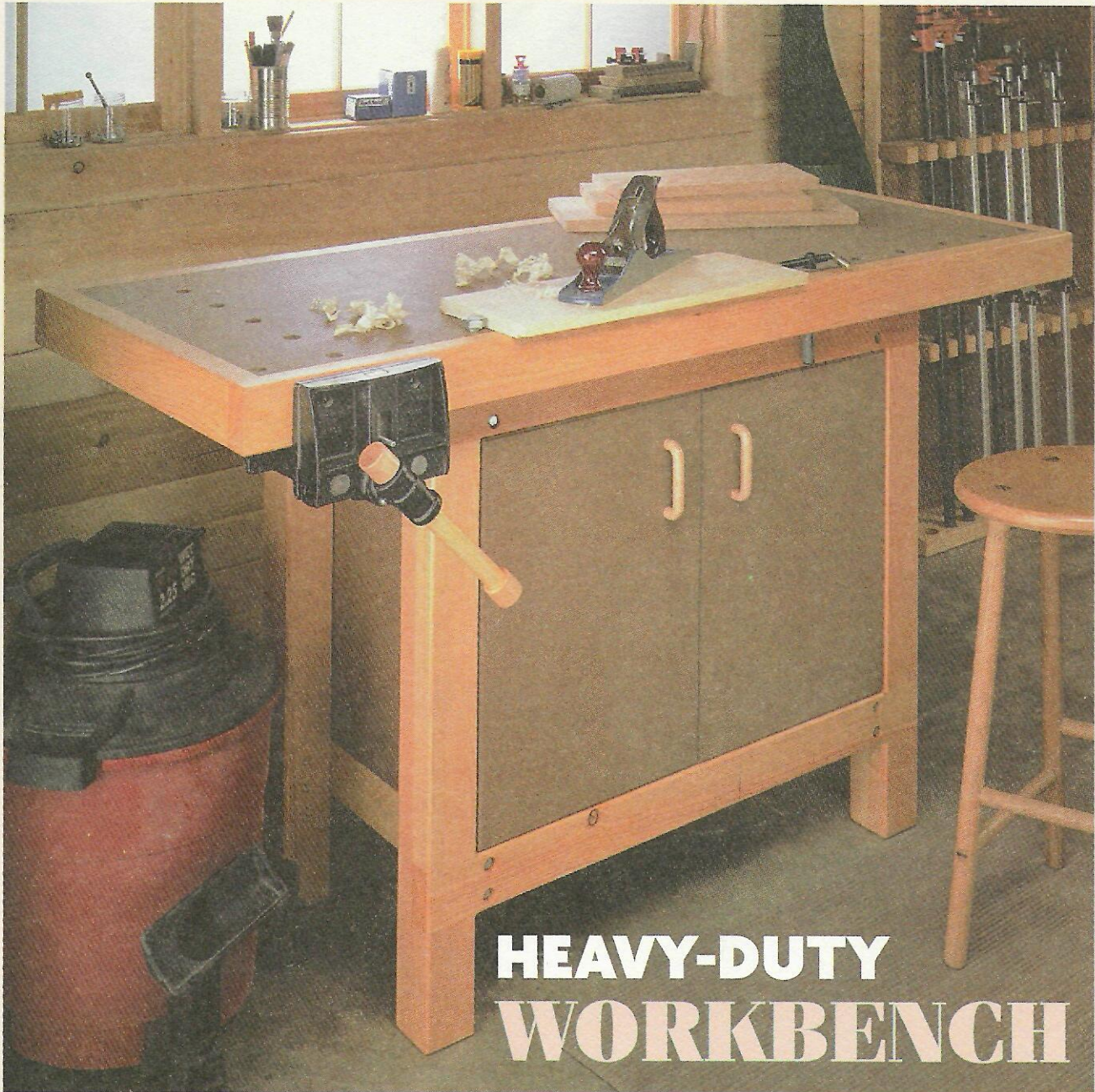

HEAVY-DUTY WORKBENCH

- Sawdust in the Small Shop
- Arching-Top Clock
- Sanding Table/Filter System
- Pattern Cutting



ShopNotes®

Issue 24

November 1995

PUBLISHER Donald B. Peschke
EDITOR Richard S. Peters
ASSOCIATE EDITORS Tim Robertson
 Phil Totten
ART DIRECTOR Cary Christensen
SENIOR ILLUSTRATOR Kurt Schultz
ILLUSTRATORS Roger Reiland
 Mark Higdon

CREATIVE RESOURCES

CREATIVE DIRECTOR Ted Kralicek
EXECUTIVE EDITOR Douglas L. Hicks
PROJECT DESIGN DIRECTOR Ken Munkel
SENIOR PROJECT DESIGNER Kent Welsh
SHOP MANAGER Steve Curtis
SHOP CRAFTSMAN Steve Johnson
PHOTOGRAPHER Crayola England
ELECTRONIC PUBLISHING Douglas M. Lidster
ELECTRONIC GRAPHICS Chris Glowacki
ELEC. COMMUNICATION Gordon C. Gaippe
GRAPHIC ARTIST Cheryl L. Cynor

CIRCULATION

Subscription Managers: Sandy Baum, Troy Dowell, Paige Rogers ■ *Assistant Subscription Manager:* Julie Greenlee ■ *Newsstand Manager:* Kent A. Buckton

CORPORATE SERVICES

Plan. Director: Jon Macarthy ■ *Controller:* Robin Hutchinson ■ *Senior Acct.:* Laura Thomas ■ *Bkpr.:* Holly Lucas ■ *Production Dir.:* George Chmielarz ■ *Prod. Mgr.:* Carol Quijano ■ *Prof. Development:* Joyce Moore ■ *Net. Adm.:* Nick Thielen ■ *Admin. Assists.:* Cheryl Scott, Julia Fish ■ *Receptionist:* Jeanne Johnson ■ *Building Maint.:* Ken Griffith

MAIL ORDER

Operations Director: Bob Baker ■ *Art Director:* Cindy Jackson ■ *Materials Mgr.:* Mark Mattussi ■ *Customer Service Mgr.:* Jennie Enos ■ *Warehouse Supervisor:* Nancy Johnson ■ *Buyer:* Linda Jones ■ *System Operator:* Tammy Aldini ■ *Team Leader:* Karla Cronin ■ *Technical Support:* David Stone ■ *Customer Service Reps.:* Jennifer Murphy, Joy Krause, Sara Kono, Anna Cox, Adam Best, Kristi Andrews ■ *Warehouse:* Gloria Sheehan, Chuck Carlson, Sylvia Carey, Larry Prine

ShopNotes® (ISSN 1062-9696) is published bimonthly (Jan., March, May, July, Sept., Nov.) by August Home Publishing, 2200 Grand Ave., Des Moines, IA 50312.

ShopNotes® is a registered trademark of August Home Pub. ©Copyright 1995 by August Home Publishing. All rights reserved.

Subscriptions: Single Copy, \$4.95. One year subscription (6 issues), \$19.95. Two years (12 issues), \$35.95. Canada/Foreign, add \$5.00 per year.

Second Class Postage Paid at Des Moines, IA and at additional offices.

Postmaster: Send change of address to ShopNotes, Box 11204, Des Moines, IA 50340-1204

Subscription Questions? Call 1-800-333-5854, 9am to 5pm, Central Time, weekdays. FAX 515-283-5854
E-Mail. Prodigy: EDJE97A, CompuServe: 75330.2301, Internet: 75330.2301@compuserve.com, America On-line: Shopnotes.

WoodNet

COMPUTER BULLETIN BOARD FOR WOODWORKERS

- Project plans and photos to download
- Woodworking Techniques Forum
- Indexes for Woodsmith & ShopNotes
- First month FREE for PC or MAC

To log on to WoodNet, call 1-515-245-9663. If you have any questions, please give us a call: (voice) 1-515-282-7000 M-F 9-5 CST.

EDITOR'S NOTE

Cutoffs

I'll never forget my first workshop. It was the second bedroom of a "single wide" mobile home. Eight foot by ten foot. Although it was small, I still managed to build a houseful of furniture. And along the way, I learned some valuable lessons.

Like making sure a project fits through the door of the shop after it's finished. (It's amazing how narrow some doors are in a mobile home.) And maybe just as important, I learned the value of containing and controlling sawdust.

A SNOWSTORM. In such a small shop, a few minutes working with a router or ripping stock on the table saw was all it took to fill the air (and my lungs) with dust. And the worst part was this dust hung in the air like the snow inside a glass paperweight, see photo.

Well, they say necessity is the mother of invention. So I quickly set out to find simple ways to control sawdust and keep it out of my lungs. From fans with filters to vacuum attachments for my tools. (For more on containing dust in the shop, see the article on page 12 and the sanding table/filter system on page 4.)

DUST MASKS. But that still didn't remove all the fine dust floating around the shop. So I got in the habit of wearing a dust mask. It's one of the most effective ways I've found to keep dust out of my lungs.

Still, even though I was used to wearing a mask, I have to admit I was a bit skeptical when a friend of mine suggested I try out his new full-face dust helmet (for a photo, see page 13).

So I took him up on his offer and stopped by his workshop one afternoon.

There he was in a cloud of dust, power sanding on his lathe.

With the helmet on, I couldn't tell if he looked more like Darth Vader or one of Jacques Cousteau's scuba divers. Nevertheless, he talked me into giving it a try. The helmet took a little getting used to, but it was surprisingly comfortable. And it worked great.

CHANGES. Just as we try new things in the shop and make changes to the way we work wood, so it is in the publishing business. There have been some changes here at Woodsmith Corporation.

Because we're growing and trying new things (such as the launch of our new gardening magazine, *Garden Gate*), we've changed our company name to *August Home Publishing*. Our new name paves the way for us to continue to try new things in the "how-to" area — like additional publications.

The only change here at *ShopNotes* is Don is now the publisher (a role he has been moving towards for some time now), and I've picked up the responsibilities of editor.

But nothing is going to change that much. As always, we will continue to bring you practical and unique jigs, projects, tips, and techniques to make your time in the shop more enjoyable.

If you have the time, drop me a line and let me know how things are going in your shop. Send a photo of your workshop or latest project. Or share a tip, story, or anecdote. I always enjoy hearing from other woodworkers who know what it's like to scratch their heads and wonder how they're going to get that project through the shop door. 📧

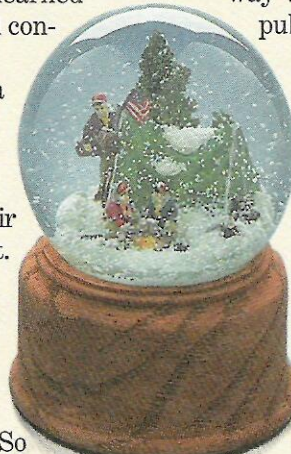

Rick

Contents

Projects & Techniques

Sanding Table & Air Filter System _____ 4

Solve two problems at once with this mobile sanding table. It collects the dust produced when sanding. And it filters fine dust particles out of the air.

Pattern Cutting on a Band Saw _____ 8

You can cut identical curved pieces quickly and accurately on the band saw by using this simple technique.

Arched-Top Clock _____ 10

It's hard to stop after making just one of these arched-top clocks. We offer several tricks to get "production" rolling.

Heavy-Duty Workbench _____ 16

You won't spend a lot of time or money building this sturdy workbench. Made from ordinary construction materials, its large work surface provides several clamping options.

Departments

The Small Shop Sawdust in the Small Shop _____ 12

Two strategies for dealing with dust. Contain as much as possible at the tool that produces the dust. And use filters to keep the fine dust particles out of your lungs.

Great Tips Layout Tips _____ 14

From making a center marker to drawing arcs, here's a collection of quick tips for getting accurate layouts.

Selecting Tools Band Saws _____ 22

Confused about the best band saw to buy? Our three-man team puts six medium-duty saws to the test and offers practical suggestions on which one to choose.

Readers' Tips Shop Solutions _____ 28

Our readers offer their own shop-tested solutions to some of the most common woodworking problems.

Lumberyard Softwood Plywood _____ 30

Knowing the different grades of softwood plywood will help you select the best material for the project at hand.

Finish Room Specialty Finishes _____ 31

Two special finishes with a twist. One creates the look and feel of granite. The other gives the appearance of marble.

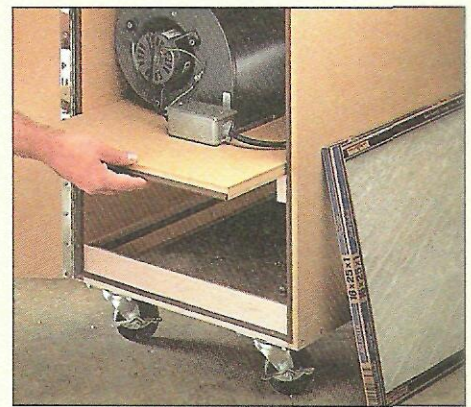

Sanding Table page 4



Arched-Top Clock page 10

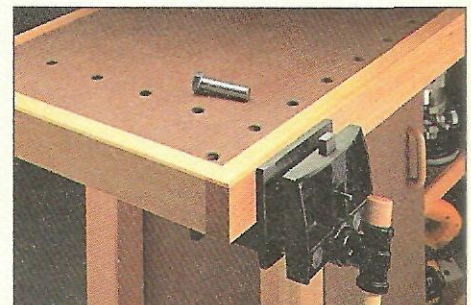

Workbench page 16

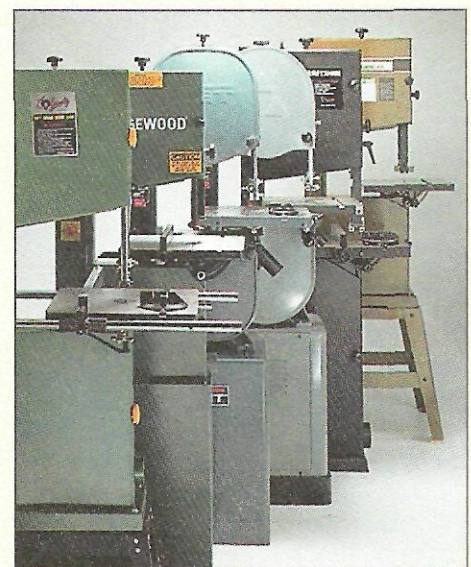

Band Saws page 22

Sanding Table

& Air Filter System

On the outside, this sanding table and air filter system looks like an ordinary cabinet. It's not until you open the door and look inside that you start to appreciate how it really works.

BLOWER/MOTOR. At the center of the system is a blower/motor that pulls air down through a perforated top, see the drawing below. This way, the fine dust that's produced when sanding is drawn *inside* the cabinet instead of filling the air in the shop.

But there's more to this project than just a sanding table. Even when you're not sanding, it doubles as an air filter system for the shop.

FILTERS. What makes this work is the air passes through a series of three standard furnace filters — two above the blower and one below, see drawing

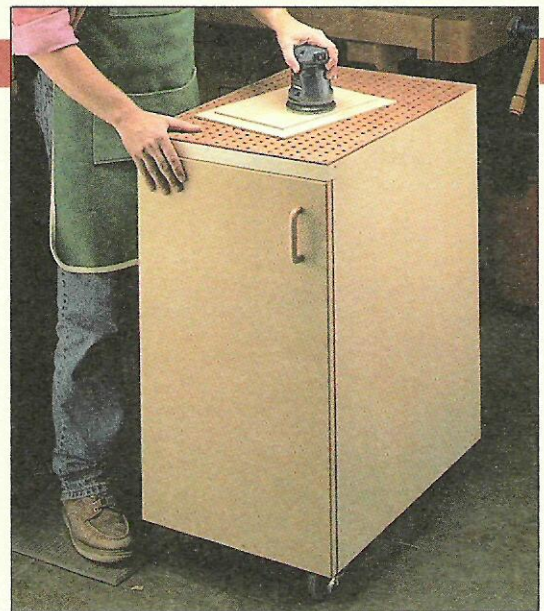

▲ This shop-built sanding table pulls in the dust that's produced when sanding. And it doubles as an air filter system for your shop.

below. These filters screen dust particles out of the air before it's returned to the shop.

Note: We used a 1/8 hp motor/blower that moves 465 cubic feet of air per minute (cfm). For a complete hardware kit that includes the blower, see list below.

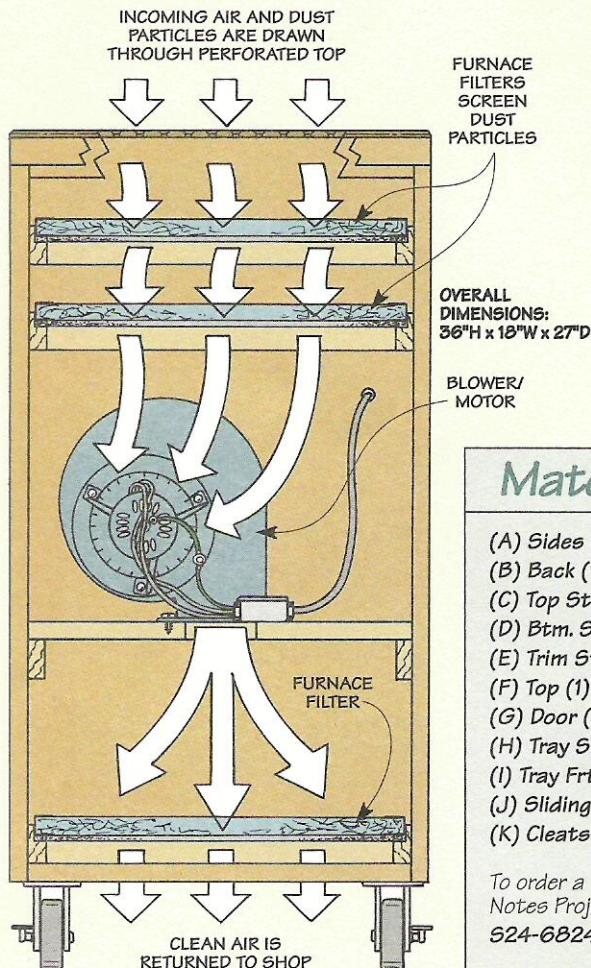

Case

I started on the sanding table by making the case, see Fig. 1. In addition to supporting the top, it houses the air filter system. To provide an exhaust for the air from the blower, the bottom of the case is open. And the front is left open for a door that's added later.

The *sides* (A) and *back* (B) of

the case are made from 3/4"-thick MDF (but plywood would also work), see Fig. 1. These pieces are held together with a rabbet and groove joint. To ensure a tight fit, it's best to cut the groove in the sides first, see Fig. 1a. Then cut rabbets in the back to form a tongue that fits the groove.

Materials & Hardware

- | | | |
|-------------------------|------------------------------|---|
| (A) Sides (2) | 26 1/4" x 32" - 3/4" MDF | • (1) 465 cfm Squirrel Cage Blower |
| (B) Back (1) | 17" x 32" - 3/4" MDF | • (2) 3"-dia. Fixed Casters |
| (C) Top Stretcher (1) | 3/4" x 1 3/4" - 16 1/2" | • (2) 3"-dia. Swivel Casters (Locking) |
| (D) Btm. Stretchers (2) | 3/4" x 3" - 16 1/2" | • (16) #14 x 5/8" Panhead Screws |
| (E) Trim Strip (1) | 3/4" x 1 1/4" - 18" | • (16) 1/4" Flat Washers |
| (F) Top (1) | 18" x 27" - 1/4" Pegboard | • (12) #8 x 1" Fh Woodscrews |
| (G) Door (1) | 18" x 30 1/16" - 3/4" MDF | • (18) #12 x 3/4" Fh Sheet Metal Screws |
| (H) Tray Sides (6) | 3/4" x 1 3/4" - 25 1/2" | • (1) 1 1/2" x 30" Piano Hinge w/Screws |
| (I) Tray Frts./Bks. (6) | 3/4" x 1 3/4" - 16" | • (12) #8 x 2" Fh Woodscrews |
| (J) Sliding Shelf (1) | 16 1/2" x 25 1/2" - 3/4" MDF | • (30) #8 x 1/4" Fh Sheet Metal Screws |
| (K) Cleats (2) | 3/4" x 1 3/4" - 25 1/2" | • (6) #10 x 5/8" Panhead Screws |

To order a complete hardware kit, call ShopNotes Project Supplies at 1-800-444-7527. 524-6824-150.....\$179.95

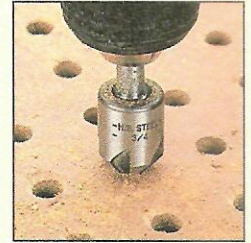
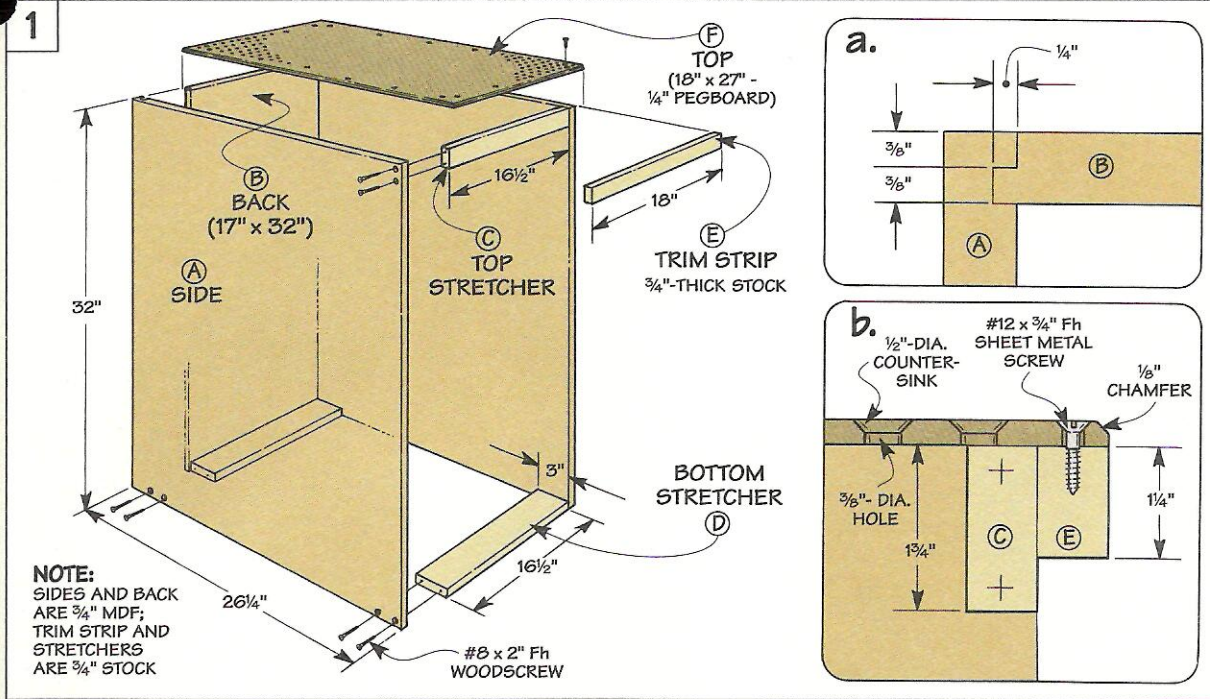

To increase airflow, first enlarge the holes in the top. Then chamfer the edges with a countersink.

STRETCHERS. To add rigidity, three hardwood stretchers span the case. A narrow *top stretcher* (C) runs across the front of the case and helps support the top. And two wider *bottom stretchers* (D) double as mounting platforms for casters (added later).

ASSEMBLY. After dry assembling the case and cutting the stretchers to fit, you can glue the sides and back together. Then just screw the stretchers in place, see Figs. 1 and 1b.

TOP. The next step is to add the top of the sanding table. It's supported by the case and a hardwood *trim strip* (E) that's glued to the top stretcher (C).

To draw dust down into the case, the *top* (F) is made from a piece of 1/4"-thick pegboard that's cut to fit flush with the case. But before attaching the top, there are a couple of things to do.

To improve the airflow, enlarge each opening in the pegboard by drilling a 3/8" diameter hole, see Fig. 1b. Then, after countersinking the holes (see margin), simply screw the top in place and rout a small chamfer around the edges.

DOOR. To provide easy access to the air filter system, the next step is to add a *door* (G), see Fig. 2. It's a piece of 3/4" MDF that's cut to the same width as the case (18"). But to provide clearance when opening and closing the door, it's 1/16" less than the distance between the trim strip and the bottom of the case (30 1/16"). After

attaching the door with a piano hinge, I added a wood pull and a pair of roller catches.

CASTERS. Now all that's left is to screw casters to the bottom stretchers. To make the table easy to roll (yet still provide a stable work surface), I used two locking swivel casters in front and fixed casters in back, see Figs. 2 and 2b.

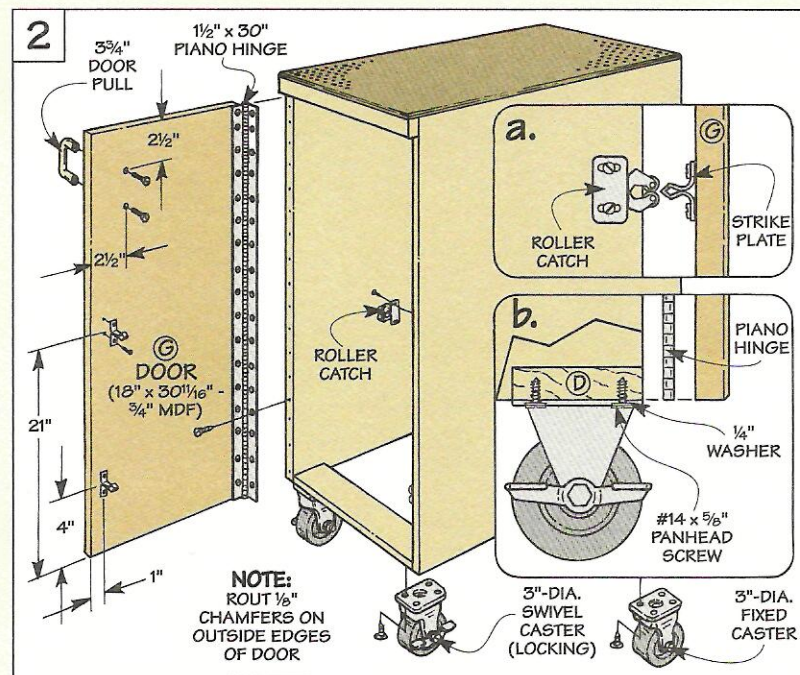

Air Filter System

The thing that's unique about this sanding table is it also works as an air filter system. So even if you're not sanding, you can cycle the air in the shop through the table and remove the fine particles of dust.

There's nothing complicated about the air filter system. It consists of three fixed trays that hold furnace filters and one sliding shelf that serves as a mounting platform for the motor/blower, see the drawing below.

FIXED TRAYS. Each of the fixed trays is identical — just an open frame to hold a filter, see Fig. 3. Two of these trays are located *above* the blower while the third one is *below*.

This way, the filter at the top removes the dust from the incoming air. And the other two filters collect any dust that gets through the first one. As a result, the air is practically dust free when it circulates back to the shop.

Each tray has two *side pieces* (H) and a *front and back piece* (I) made from 3/4"-thick hardwood,

see Fig. 3. All of these pieces have a rabbet cut in the top edge to accept the filter, see Fig. 3a. Then, after cutting a notch in the end of each side piece to accept the front/back, the trays are simply glued and screwed together, see Figs. 3 and 3b.

INSTALL TRAYS. Once you've completed all three of the trays, it's just a matter of screwing them to the case, see Fig. 4 and the drawing below left. To keep dust from traveling from one layer to the next, I added strips of self-adhesive weatherstrip to the bottom of the rabbets before installing the filters, see Fig. 4a.

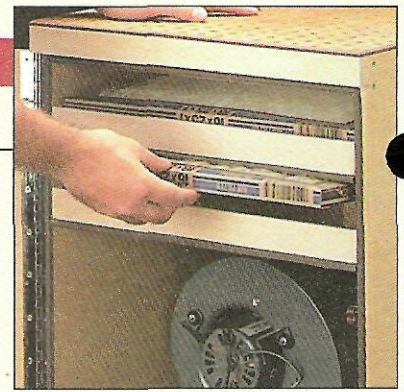

Filters. Ordinary furnace filters above and below the motor/blower clean dust particles out of the air.

SLIDING SHELF. With the fixed trays in place, you're ready to add the *sliding shelf* (J), see Fig. 5. It's a piece of 3/4" MDF that acts as a mounting platform for the motor/blower. And since it slides in and out of the case on a pair of

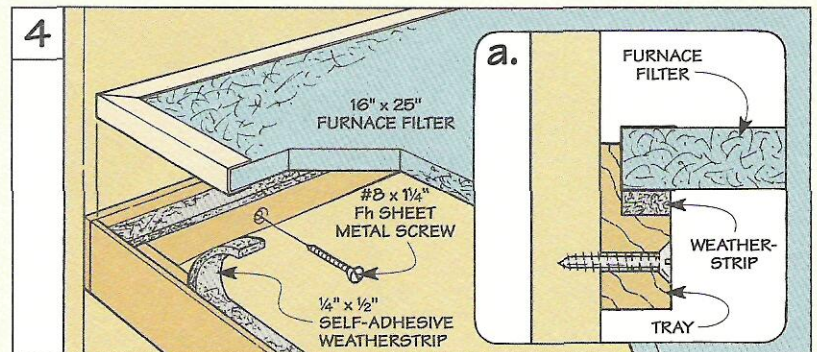
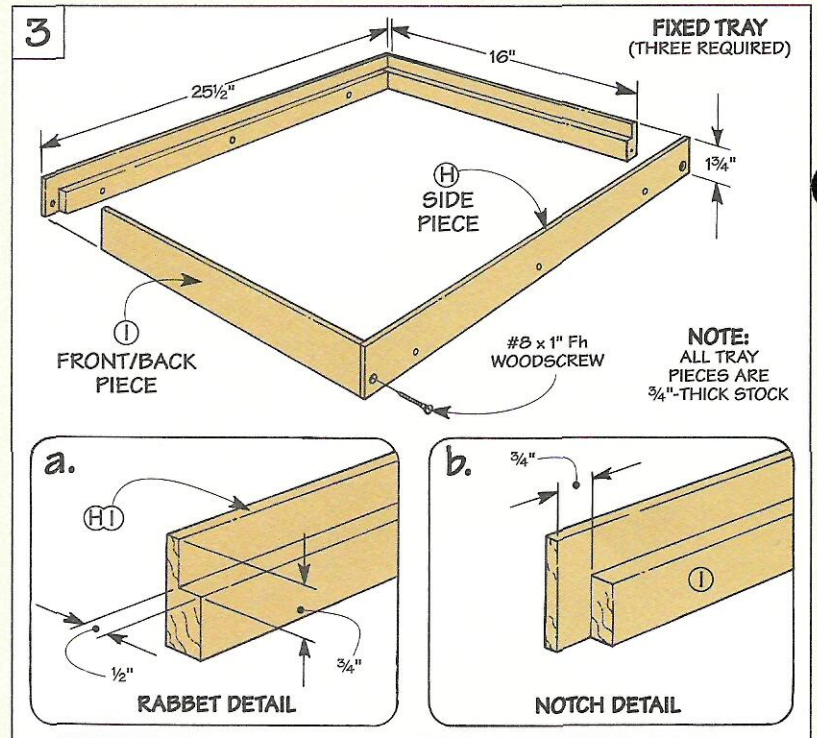
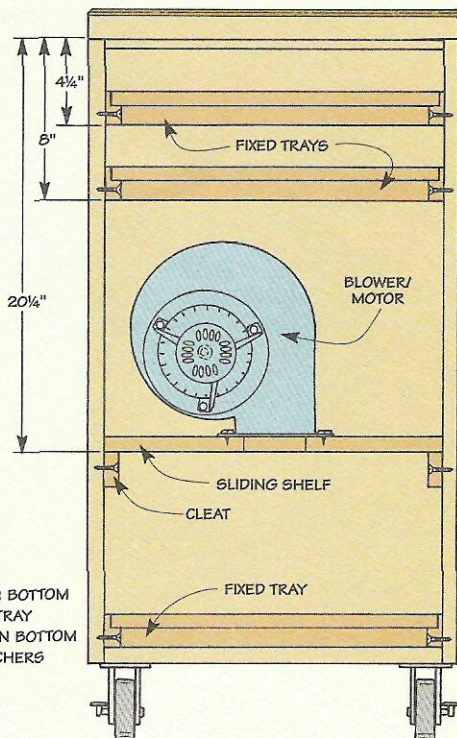

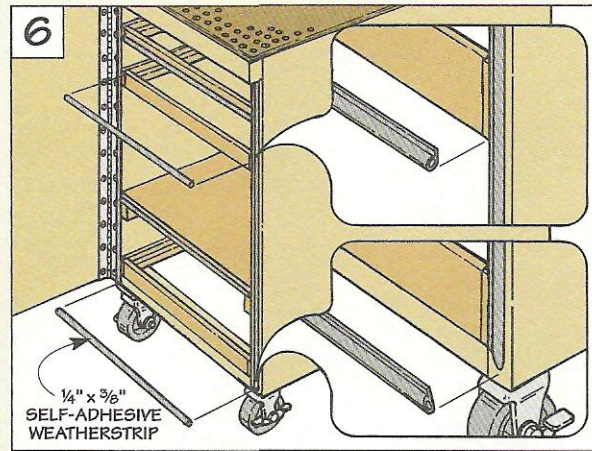
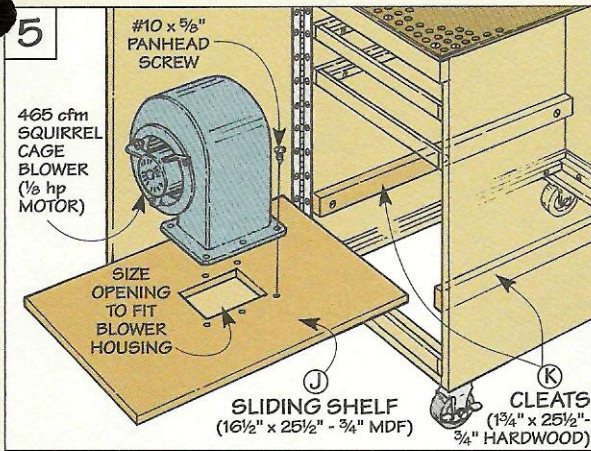

cleats (added later), it's easy to lubricate the blower periodically or blow out any dust that accumulates around the vents.

After cutting the shelf to fit inside the case, you'll need to cut an opening for the blower's exhaust to pass through. To distribute this air equally in all directions, it's best to cut the opening so it's centered on the shelf. Then mount the blower with screws.

To support the weight of the motor/blower (and allow it to slide in and out), it rests on two cleats (K). These are pieces of 3/4"-thick hardwood that are glued and screwed to the inside of the case, see Fig. 5 and the drawing on opposite page.

WEATHERSTRIP. Before hooking up the motor/blower, I applied weatherstrip to the front edges of the case, shelf, and trays,

see Fig. 6. But this time, to stand up to the wear and tear of repeatedly opening and closing the door, I installed a more durable weatherstrip like the kind used on exterior doors (it's available at most hardware stores).

HOOKUP. All that's left to complete the sanding table and air filter system is to hook up the motor/blower. For more on this, see the box below.

Electrical

- (1) 15 Amp, 125 Volt Plug (Grounded)
- (5) No. 8 Spade Terminals (16/14 ga.)
- (2) Utility Boxes
- (1) Box Cover - Duplex
- (1) Box Cover - Blank
- (1) 15 Amp, 120 Volt Switch/Receptacle
- (4) #8 x 5/8" Ph Sheet Metal Screws
- (2) Grounding Pig-tails w/Screws (12 ga.)
- (4) 3/8" Cable Connectors
- (5) Wire Nut Connectors (Yellow)
- 16-3 SJ Electric Cord (18 feet)

Electrical Hookup

There are a couple of different ways to hook up the sanding table.

The simplest one is to connect the "pigtail" that comes from the motor/blower to a length of electric cord, see Fig. 1. Then just run the cord through a hole in the back of the cabi-

net and wire a plug on the end. With this type of hookup, you'll need to plug in the sanding table (or unplug it) each time you turn it on or off.

A handier solution is to turn the sanding table on or off with the flip of a switch. To do this, run about 6 feet

of the electric cord to a switch/receptacle that's mounted in a box attached to the sanding table, see Fig. 2. The rest of the cord runs between this box and the electrical outlet on the wall. Here again, you'll need to wire a plug on the end of the cord.

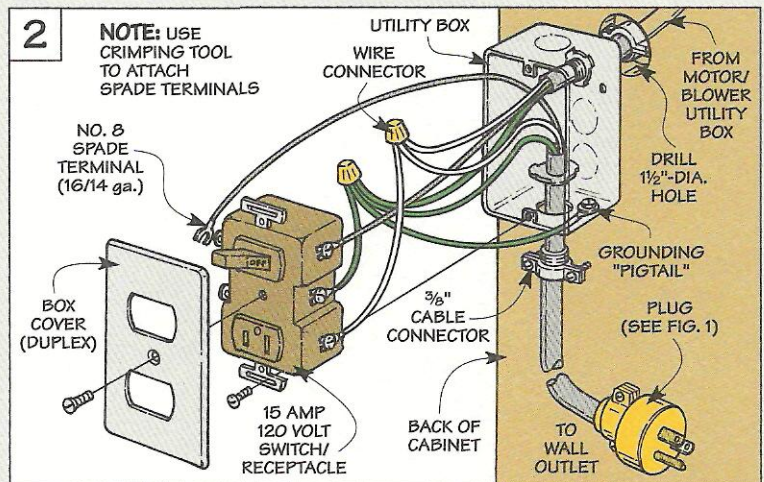
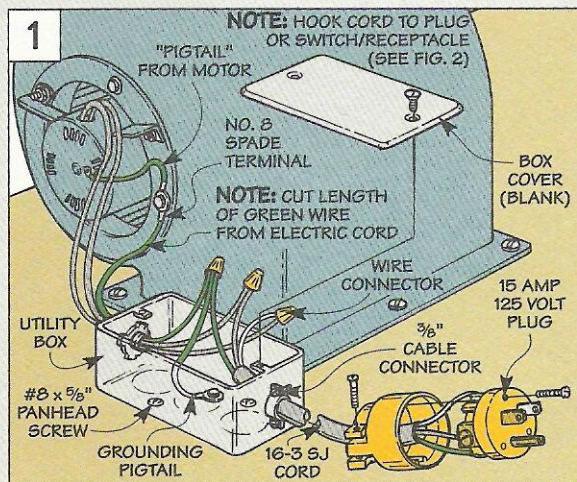

Pattern Cutting on a Bandsaw

Cut curved parts that are identical in shape with this simple bandsaw technique.

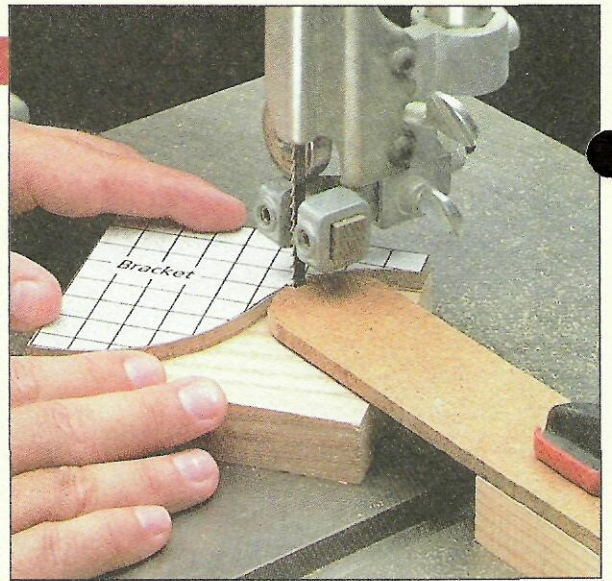

There's nothing complicated about using a band saw to cut a curve on a workpiece. Just lay out the curve, cut close to the line, and sand the edge smooth. But if you need to cut *multiple* curved parts that are *identical* in shape, this process is a bit tedious.

That's when pattern cutting on the band saw comes in handy. Instead of spending time laying out a pattern over and over again, you just attach a template to the workpiece. Guiding this template against a shop-made rub block produces a piece that's the exact same shape, see photo above.

This makes pattern cutting ideal if you're in a "production mode." For example, if you're building a set of chairs, it's easy to make duplicate curved parts. Or if you're making a number of shelf brackets or the arched-top clocks shown on page 10, you can quickly cut identical curved parts.

PATTERN. Regardless of the project, you'll need to start with a pattern. You can either draw it directly on the material you plan to use for a template. Or attach a paper pattern with rubber cement or spray adhesive, see Fig. 1. (I use Masonite or Plexiglas as a template material, see margin.)

TEMPLATE. Now you can cut the template to shape. Since any gouges or nicks in the edge of the template will transfer to the workpiece, you'll want the edges

to be as smooth as possible.

So after cutting the template slightly ($\frac{1}{16}$ ") oversize, carefully file (or sand) up to the line. Then attach the template to the workpiece with carpet tape to keep it from shifting as you guide it against the rub block, see Fig. 1.

RUB BLOCK. The rub block is nothing more than a block that

supports an overhanging arm made of $\frac{1}{4}$ " Masonite, see Fig. 2. As you make a cut, this arm "rubs" against the template which creates an exact duplicate of the shape.

To produce a smooth, flowing shape, you'll need to cut a curve on the end of the arm. But even with a smooth curve, the blade will still leave saw marks on the edge of the



To make it easy to select the best grain, you can make a template from a clear piece of Plexiglas.

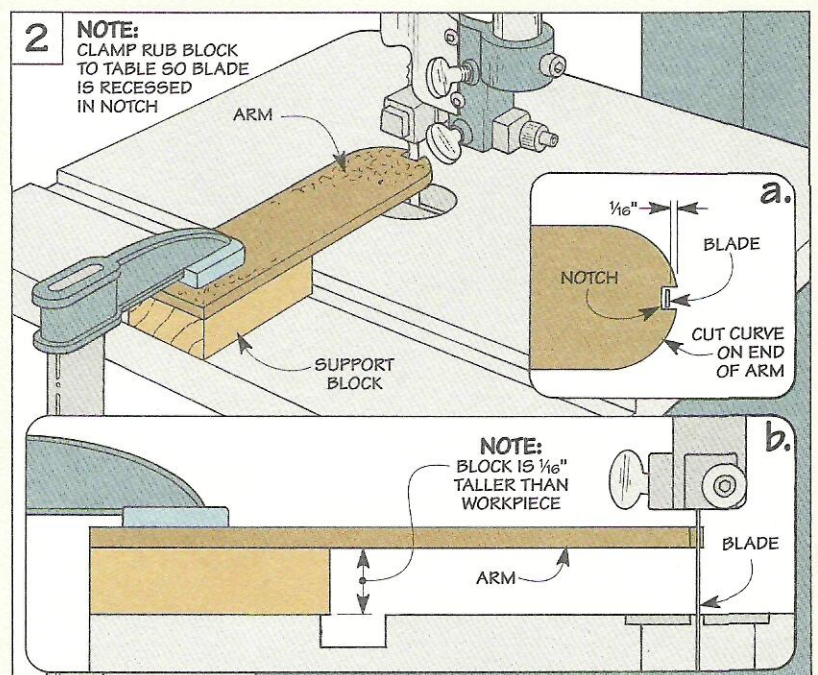
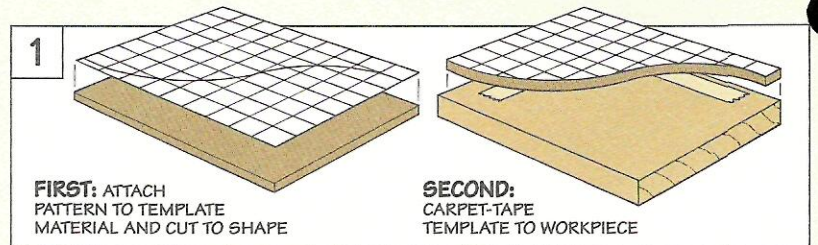

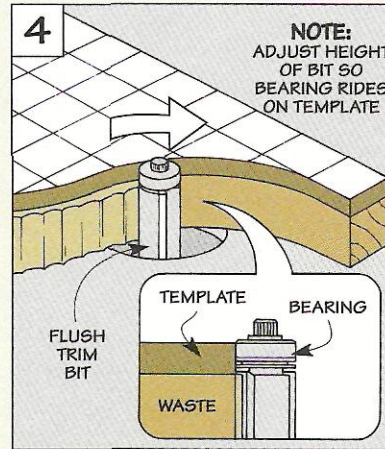
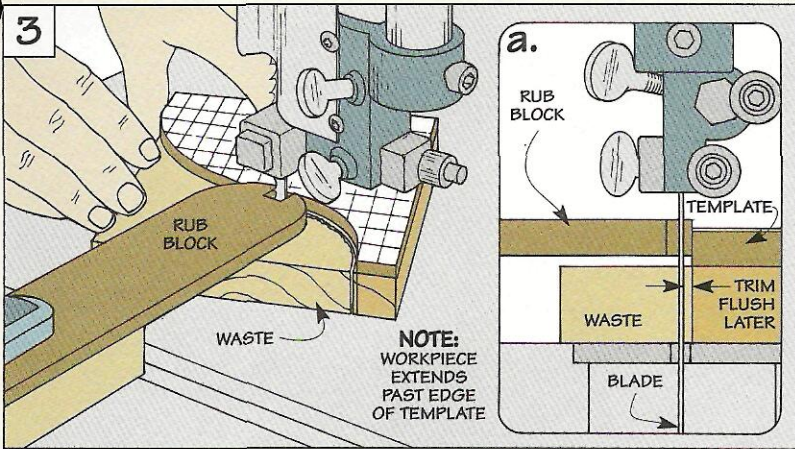

workpiece that will need to be cleaned up later. To allow a bit “extra” for this, you’ll need to build in a way to cut the workpiece slightly *larger* than the template.

To do this, cut a notch in the end of the arm that allows you to recess the cutting edge of the blade about $\frac{1}{16}$ ”, see Fig. 2a. This way, the blade will cut just shy of the template. And the workpiece will extend the same amount ($\frac{1}{16}$ ”) past the template, see Figs. 3 and 3a.

SIZE OF BLOCK. Something else to keep in mind is the height (thickness) and length of the support block.

It needs to be tall (thick) enough to allow the workpiece to slide under the arm. Yet short enough so the arm makes contact with the template. As a rule, I make it $\frac{1}{16}$ ” taller than the thickness of the workpiece, see Fig. 2b.

There’s also a tradeoff when it comes to length. The block needs to be long enough to support the arm. But the shorter it is, the more room you’ll have to spin the workpiece.

MAKE CUT. After gluing the rub block together and clamping it to the table, you can make the cut. Start with the template just touching the rub block and apply light pressure as you feed the workpiece into the blade, see Fig. 3. As you’re cutting, swing the tail end of the workpiece to the left or right to keep the edge of the template parallel to the blade.

The unusual thing here is you can’t see the blade cutting through the workpiece — it’s hidden by the template and rub block. This may seem a bit odd at first. But by keeping the template in constant contact with the rub block, the blade will automatically “trace” the shape of the template.

FINAL SHAPING. Before you remove the template, there’s one last thing to do. That’s to trim the

workpiece flush with the edge of the template. Depending on the thickness of the workpiece, I use two different approaches.

If it’s $\frac{3}{4}$ ” thick (or less), it’s easiest to rout the edge with a flush trim bit, see Fig. 4. But the cutting edge of a flush trim bit often isn’t long enough to rout a thick workpiece (like the arched-top clock). So I sand the edge flush instead, see box below. 

Flush Trim Sander

A simple way to get a thick workpiece flush with the edge of a template is to *sand* it with a flush trim sander chucked in a drill press.

Basically, it’s a drum sander with a phenolic disk mounted on the bottom. When sanding, the disk rides against the template to produce a duplicate shape.

If you’re using a thin template, you’ll need to recess the disk (and the nut that holds it in place) to ensure that the sanding drum makes contact with the entire edge. To do this, just clamp a piece of plywood with a hole cut in it to the table.

Editor’s Note: Flush trim sanders (also called *RoboSanders*) are available from the following:



- Highland Hardware
800-241-6748
- Woodcraft
800-225-1153
- Woodsmith Shop
800-444-7002

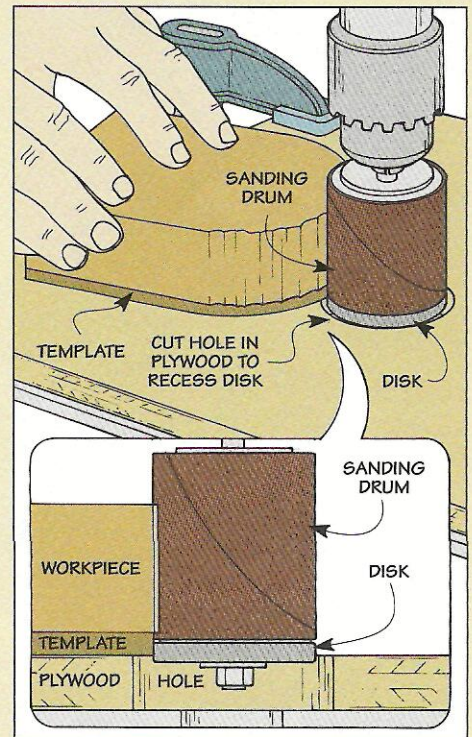



Arched-Top Clock

Whether you build one or a dozen, this arched-top clock is as good-looking as it is easy to make.

This arched-top clock drew lots of attention when Kent (our senior designer) first set it on his desk. But not nearly as much as when he lined up a half dozen of them like a row of dominoes.

The unusual thing was that all the clocks had the same basic design — but each one looked remarkably different. That's because he had used different types of wood and finishes for each clock. Such as the spalted maple clock on page 3. And the "stone" finishes shown on page 31.

Besides being an ideal project to experiment with different materials, another nice thing about this clock is it doesn't require a large, expensive bit to make an opening for the clockwork.

All it takes is a guide bushing for your router and a simple shop-made template.

And by combining the template with a pattern-cutting technique (see page 8), you can gear up to make any number of clocks quickly and easily. (See margin for sources of clockworks.)

BODY. To allow plenty of room to recess the clockwork, the *body* (A) of the clock is made from a piece of 1½"-thick stock, see Fig. 1. After cutting a blank to rough size, the next step is to make the template.

TEMPLATE. The template is just a piece of ¼" Masonite. It serves as a guide when cutting the arch on top of the body. And it allows you to rout the opening for the clockwork.

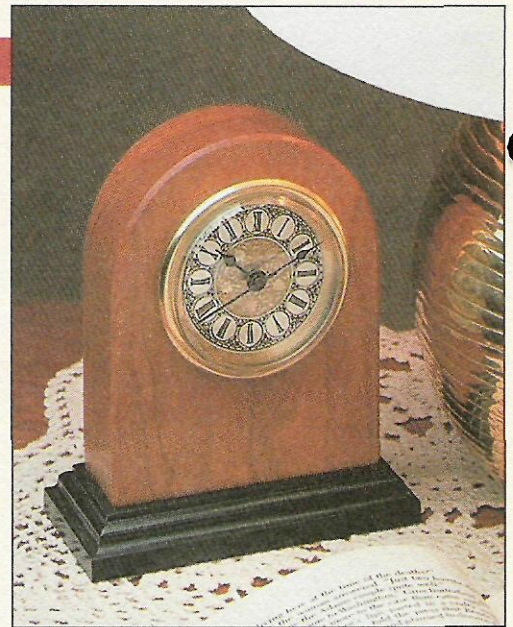

The curve on the template is the *identical* shape and size of the arch on the body of the clock, see Exploded View. But the hole in the template is *larger* than the diameter of the clockwork.

That's because the opening is routed using a metal guide bushing that attaches to the base of your router, see box on next page.

A collar on the bushing extends below the base of the router and rides against the template. So the bit doesn't cut right up next to the edge, see Fig. 2a. To compensate for this offset, the hole in the

Sources

Clockworks are available from the woodworking catalogs listed below:

- Woodcraft 800-225-1153
- Klookit 800-556-2548
- Precision Movements 800-533-2024

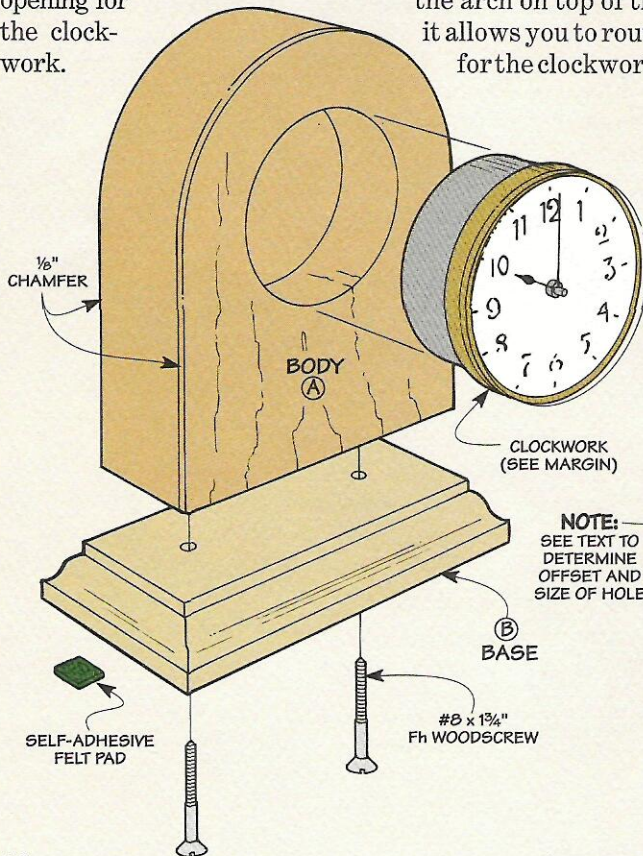

NOTE: SEE TEXT TO DETERMINE OFFSET AND SIZE OF HOLE

EXPLODED VIEW OVERALL DIMENSIONS: 5 3/4" H x 5" W x 2 1/2" D

TEMPLATE DETAIL (1/4" MASONITE)

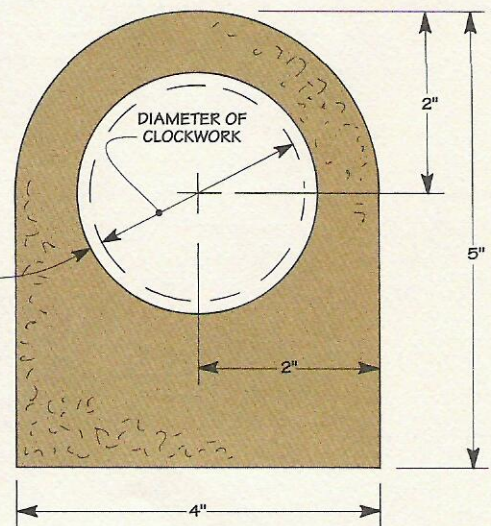

template needs to be larger than the diameter of the clockwork.

To determine the size of this hole, start by measuring the outside diameter of the guide bushing. Then subtract the size of the bit and add this figure to the diameter of the clockwork. (With a 5/8"-dia. bushing and a 1/2" straight bit for example, add 1/8" to the dia. of the clockwork (2 3/8") and cut a 2 1/2"-dia. hole in the template.)

ROUT OPENING. After carpet-taping the template to the workpiece and drilling a "starter hole" for the router bit, you're ready to rout the opening for the clockwork, see Figs. 1 and 2. What you want is to make the opening deep enough so the lip on the clockwork fits tight against the body. (In our case, 3/4" deep.)

SHAPE TOP. Once the opening is routed, leave the template in place. This way, you can use it again to bandsaw the arch on the top, refer to page 8. And it comes in handy when sanding the edge smooth as well.

CHAMFERS. All that's left to complete the body of the clock is to chamfer the front and back edges. Note: Leave the bottom edges square so the body of the clock will fit tight against the base.

BASE. The body of the clock sits on a base (B) made from a piece of 3/4"-thick medium-density fiberboard (MDF), see Fig. 3. Routing a profile on the edges of the base gives the clock a light, airy look. (I used a 1/4" Roman ogee bit.)

FINISH. Before assembling the clock, it's easiest to apply a finish. I especially liked the contrast between a painted base and the clear finish applied to the body, see photo on page 10.

ASSEMBLY. Finally, it's just a matter of assembling the clock with screws. After pressing the clockwork into the opening, apply self-adhesive felt pads to each corner of the base to protect the surface it rests on.

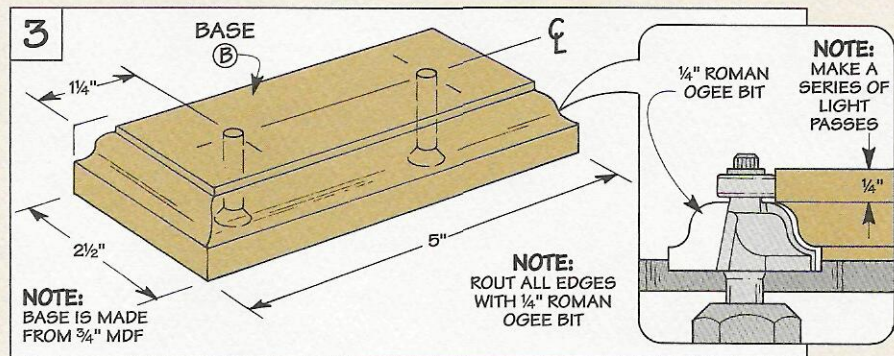
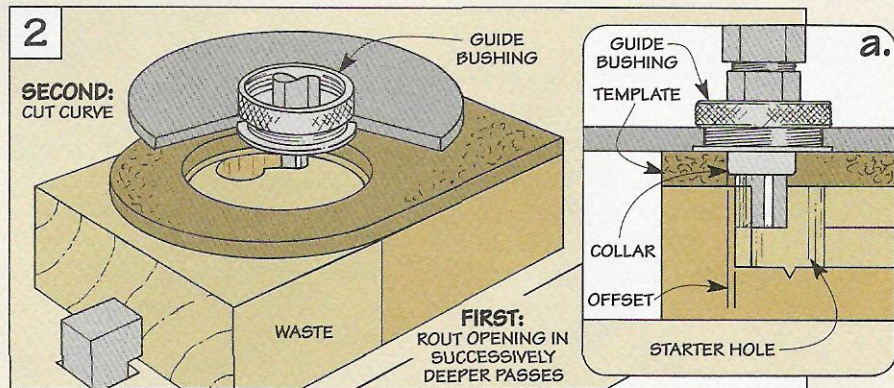
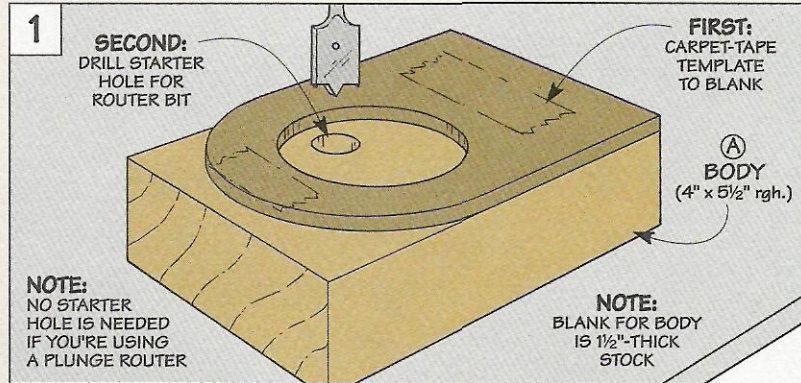

Guide Bushing

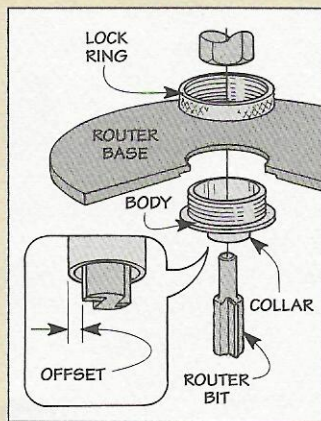

A quick, accurate way to rout a duplicate shape is to attach a guide bushing to the base of your router. (These are available through most woodworking stores and catalogs.)

One common type of guide bushing has a threaded body that's secured to the base with a lock ring, see drawing. A collar on the body of the guide bushing extends below the router base and rides against a template that's attached to the workpiece.

The thing to keep in mind is there's an offset between the cutting edge of the bit and the collar. So you'll need to adjust the size of the template to compensate for the offset, refer to text above.

Sawdust in the small shop

Here are a number of strategies you can use to contain and filter out harmful dust in your shop.

Dealing with dust in the shop is one of the toughest problems facing a woodworker. And when the workshop is small, the problem is compounded. In just seconds, a power tool can kick up dust in the shop just like the snow that swirls around inside a glass paperweight, see the photo on page 2.

TWO PROBLEMS. One thing that makes dealing with sawdust in the small shop such a chal-

lenge is you're actually faced with two different problems.

First, you'll need to find a way to handle the mess that the tools create. From the large chips your jointer or planer produces to the dust a table saw or radial arm saw kicks up. Even the fine dust generated by a power sander which ultimately ends up coating everything in your shop.

And second, you'll need to develop a strategy for keeping harmful dust out of your lungs. Fortunately, there are a number of simple (and some surprisingly economical) ways to take care of both problems.

CONTAINING DUST

It's no surprise that the most common solution to containing dust is to use a small dust collection system. You can pick from a wide variety of quality single or two stage collectors, like the one show in the left margin. With a little advance thought, it's often possible to pick a central location in the shop that can service the majority of your tools.

The disadvantage to these systems is they take up a lot of valuable space. And they range in price from \$300 to \$800 (not including the hook-ups and pipe).

SHOP-VACS. A more economical option is to purchase several

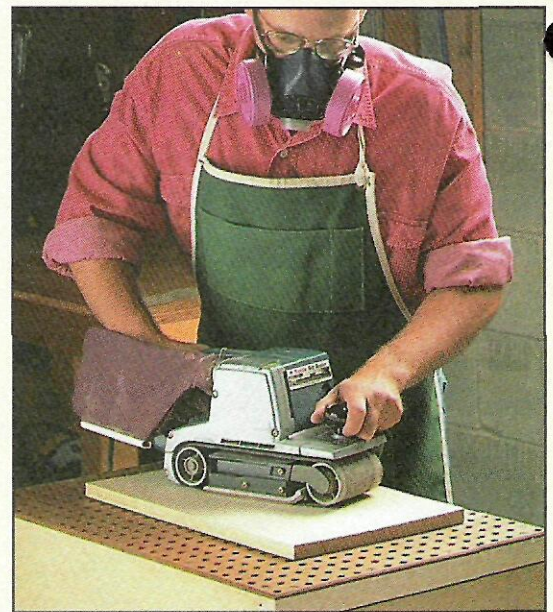

small shop-vacs (\$50 to \$100) and dedicate each one to single machine, see bottom left photo. To make this set-up even more convenient, you can purchase an automated switch from many mail-order woodworking catalogs, see sources on page 13. This switch turns on the shop-vac for you automatically whenever you power up the tool.

HOOK-UPS. Besides handling your stationary tools, there's another advantage to a shop-vac or dust collector. You may be able to hook them up to one of the largest dust producers in the shop — power sanders.

Many sanders offer a vacuum hook-up, see photo below. Or a dust bag, see photo above. If your



◀ **Dust Collector.** If you've got room, a dust collector is one of the most effective ways to contain dust in the shop.

▶ **Shop-Vacs.** An alternate solution is to dedicate an inexpensive shop-vac to each sawdust producing machine.

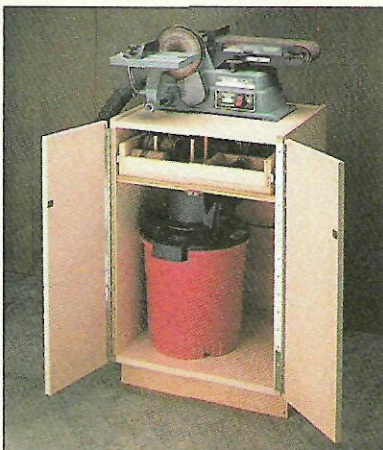

Sanding Dust. A built in vacuum (left) or an attachment (right) are two ways to control sanding dust.



Fan Filter. One way to reduce air-borne dust in the shop is to attach a pleated filter to a household fan.

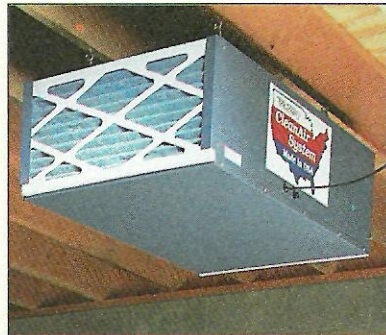

Suspended Filter. If floor space is a premium, consider a filter unit that can be suspended overhead.

model doesn't have either, see if they're available separately. If not, it might be a good time to upgrade to a sander with built-in vacuum assist, see bottom right photo on page 12. These sanders pull dust up through holes in the sandpaper. They're amazingly effective *and* highly portable.

FILTERING DUST

But even the best dust collection system won't filter out all the dust. And it's this fine dust that

will coat both your shop and the inside of your lungs.

FAN/FILTER. One of the simplest and most economical ways to capture dust is to pull it into a fan with a pleated furnace filter strapped over the intake, see top left photo. Just position the fan near the source of the dust. And to further increase the efficiency, try using two fans — one to blow the dust into the other.

FILTER UNIT. Another option is to purchase (or build) a filter unit to clean the air whenever you're working in the shop. Here again, one of the simplest methods is to use an inexpensive fan with a pleated filter.

The more sophisticated filter units can be moved around the shop where the dust is being produced. Or you can hang them from the ceiling over a particularly bothersome dust source, see top right photo above. (Note: You can even combine the filter with a work surface to create a mobile sanding table/filter box, see page 4 for our shop-built version.)

DUST MASKS. Whether or not you decide to live with a layer of sawdust in your shop, you can still protect your lungs by always using a good quality dust mask, see top photo at right and sources at left. When buying one of these, it's a good idea to pay a little more for a system that has replaceable canisters that can filter both sawdust

and chemical fumes (around \$50).

DUST HELMET. A dust mask will keep the dust out of your lungs but not out of your eyes. For complete protection from dust, you may want to consider a dust helmet.

Advances in technology have allowed manufacturers to produce lightweight self-contained units that are surprisingly comfortable, see bottom photo below. Although they cost considerably more than a dust mask (around \$300), they do an excellent job of keeping airborne dust out of your face and lungs.

A FINAL NOTE. Every now and then, I receive a disheartening letter from an avid woodworker who had to hang up his tools because of a respiratory problem caused by sawdust.

Although it's tempting, don't avoid the dust problem. Take an aggressive stance. Invest the time and money in your lungs *now*. You'll breathe easier, and your shop will be cleaner, too. 🛠️



◀ **Dust Mask.** An economical way to keep dust out of your lungs is to use a dust mask with replaceable filters.

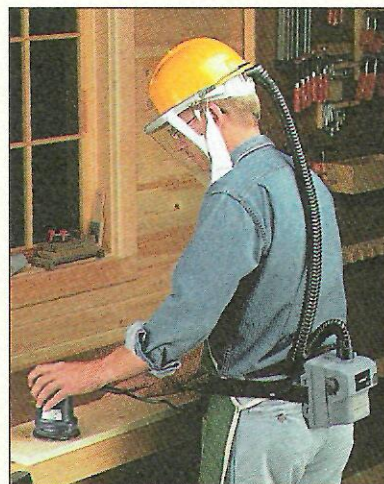

◀ **Dust Helmet.** A good way to keep dust out of your lungs and face is to use a self-contained dust helmet.

Sources

Garrett Wade
(800-221-2942)

Dust Masks, Vacuum-assist Sanders

Racal Health & Safety, Inc
(800-682-9500)

Dust Masks, Dust Helmets

Tool Crib

(800-358-3096)

Dust Collectors, Airborne Filters, Shop Vacuums, Vacuum-assist Sanders, Dust Masks, Dust Helmets

Trendlines

(800-767-9999)

Dust Collectors, Vacuum-assist Sanders, Dust Masks

Woodcraft

(800-225-1153)

Vacuum-assist Sanders, Dust Masks, Dust Helmets

Woodworkers' Store

(800-279-4441)

Vacuum-assist Sanders, Dust Masks

Woodworker's Supply

(800-645-9292)

Dust Collectors, Vacuum-assist Sanders, Dust Masks

Layout Tips

Here are some great tips to help you with common layout problems you might encounter.

Center Marker

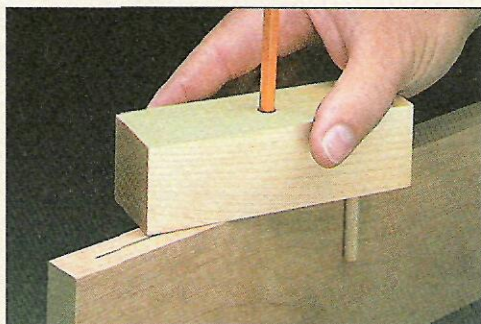

■ Sometimes you need to find the center of an edge of a board. To do this quickly and accurately, I use a shop-made center marker, see photo. It's just a block of wood with a pair of 1/4" dowel guides and a pencil, see drawing.

The block is sized to fit most thicknesses of stock, see drawing. The dowel guides glued in holes

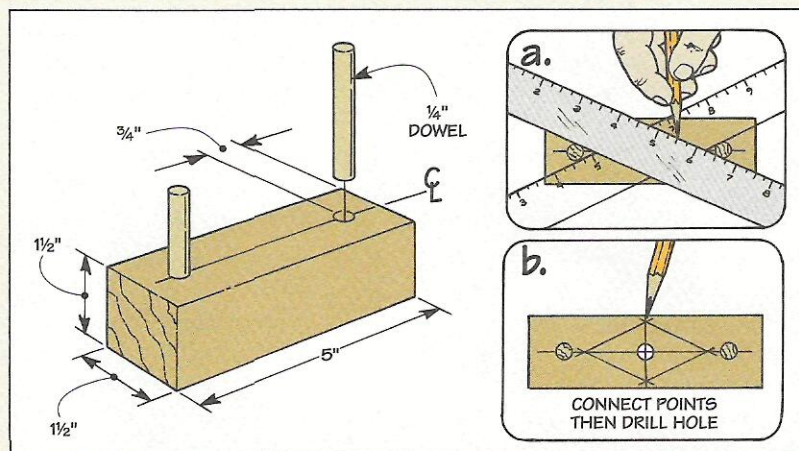

near the ends of the block will center a pencil (added later) along the edge of a board. A hole drilled *exactly* between the guides accepts a pencil, see details a and b.

To use the marker, stand your

workpiece on edge and place the center marker on the edge so one guide is against each face, see photo. Then simply keep both guides against the sides as you slide the marker along the edge to mark the center.

Scribing

■ One way to scribe a parallel line around a workpiece is to trace the workpiece with a compass. But if the compass isn't held exactly perpendicular to the edge of the workpiece or the points of the compass are set too close together, the scribe line may not end up parallel all the way around the workpiece, see detail a.

The best way I've found to ensure a parallel line around a workpiece is to use a "posterboard scribe," see drawing and detail b.

The scribe is just a small piece of posterboard with a hole punched in it for the tip of a pen-

cil. The hole is located in the scribe the desired distance you want the line from the workpiece.

By using posterboard instead of a compass, there's a much

larger pivot point for making contact with the edge of the workpiece — which results in a more uniform, more parallel line around the workpiece.

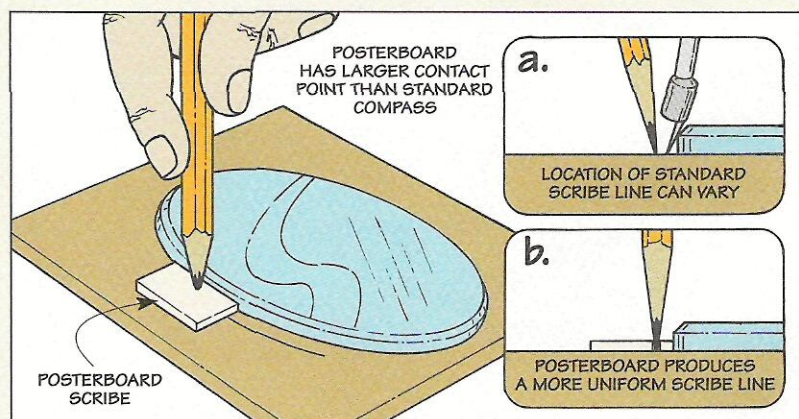

Drawing Arcs

■ You don't need a giant compass to lay out a large arc. There are a number of simple ways to do it. It all depends on the size of the arc.

KNOWN RADIUS. If you know the radius of the arc you want to draw, you can make a simple trammel out of a strip of wood, see Fig. 1. One end of the trammel has a notch cut in it to hold a pencil. The other end has a hole for a nail that sets the radius.

UNKNOWN RADIUS. If the radius of the arc is unknown but you know its general shape, then all you have to do is bend a thin strip of wood to the shape of the arc and trace around it (Masonite also works well), see Fig. 2.

If you're laying out an arc with a radius that's too tight to bend a strip of wood around, try using an 1/8"-thick piece of *Plexiglas*, see Fig. 3. It's very flexible and something you're more likely to keep.

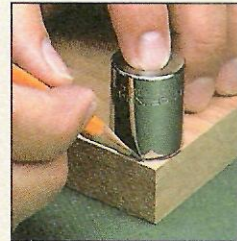
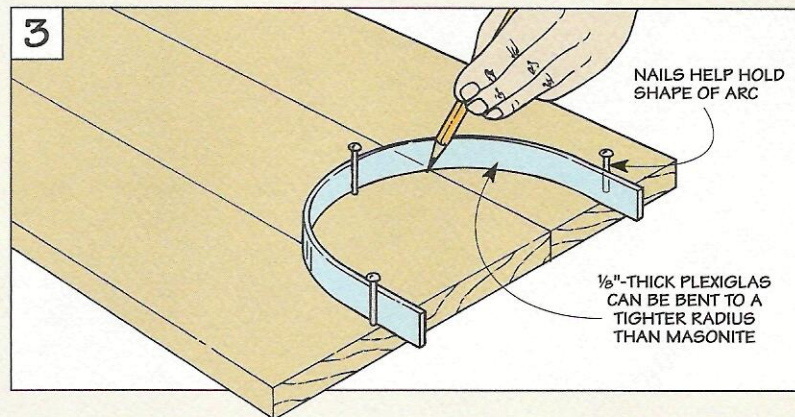
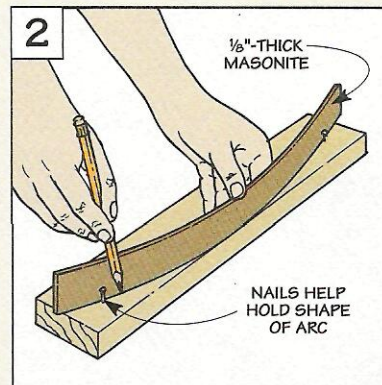
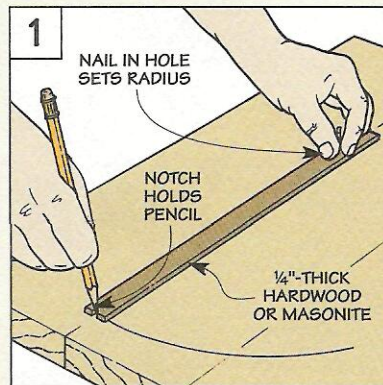

The next time you have to draw a small-radius arc, try using a socket as a template.

Flexible Curve

■ One of the simplest ways I've found to duplicate an existing curve is to use a shop-made flexible curve. It's made from a length of vinyl tubing and some plumber's solder, see drawing.

The plumber's solder allows the curve to hold its shape after it has been bent. And the vinyl tubing provides a smooth surface for your pencil to trace.

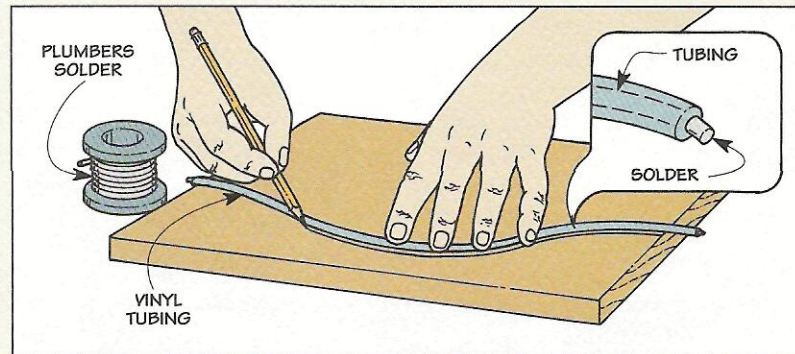
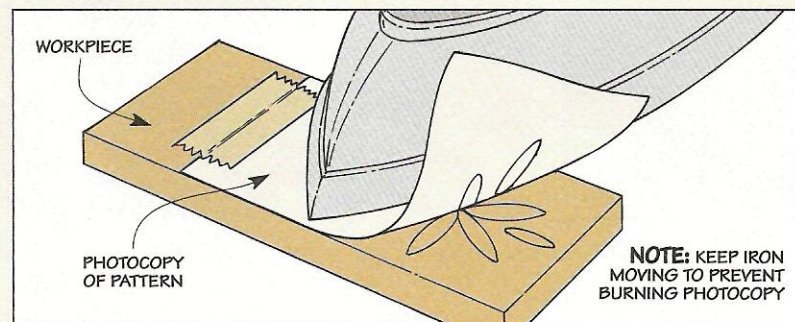
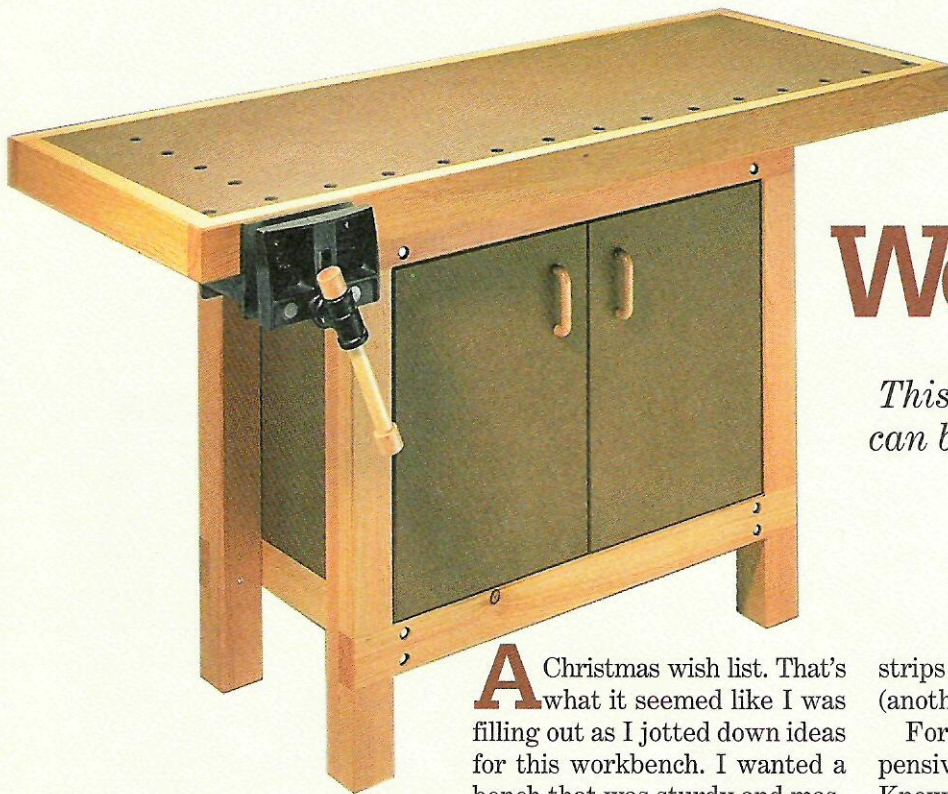

Photo Copy Transfer

■ Here's a quick and easy way to transfer a mirror image of a pattern onto a workpiece.

First, make a photocopy of the pattern. Then place the copy face down on your workpiece. Now with an iron set on high, iron the back of the copy to transfer the pattern. (Note: Make sure to keep the iron moving.)





Heavy-Duty Workbench

This sturdy, massive workbench can be built in a weekend without breaking the bank.

A Christmas wish list. That's what it seemed like I was filling out as I jotted down ideas for this workbench. I wanted a bench that was sturdy and massive, yet easy to build out of commonly available material. And of course, there had to be storage.

Fortunately, it didn't take a visit to Santa to make this bench a reality — just a trip to the local home center. The secret to fulfilling my wish list was in selecting the right materials.

MATERIALS. I started with the material for the top. I was looking for something that was flat, solid, and stable. Something that could take a lot of abuse.

The answer was MDF, or medium-density fiberboard. A double layer of this along with extra strips of MDF around the edges and some fir edging creates a *massive* top, see photos A and B. The extra

strips of MDF also provide support for bench dogs (another item on my wish list).

For the base, I needed a material that was inexpensive, yet sturdy. So I went with Douglas Fir. Known for its strength, it's the perfect material to support the top and stand up to the blows of a mallet when assembling a project or hand cutting dovetails. For maximum stability, I bolted the base together. And "built-up" the joinery so it was quick and easy to build.

STORAGE. To provide storage for tools, jigs, and hardware, a cabinet slips into the opening in the base. An adjustable shelf inside makes it easy to customize the space for your needs, see photo C.

This cabinet also adds to the mass of the bench (for a total weight of around 300 lbs.) to help it remain steadfast during even the most demanding tasks like sawing, planing, or assembly work.

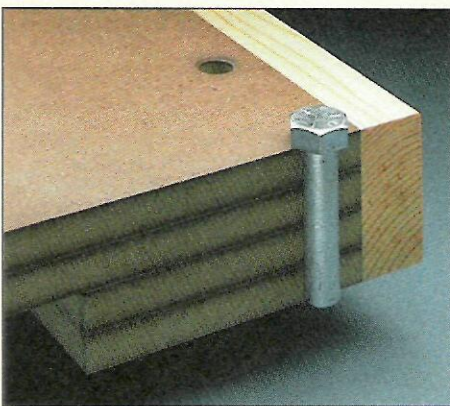

A. Built-up Top. Building up the top increases its density and allows you to drill holes for a bench dog system.

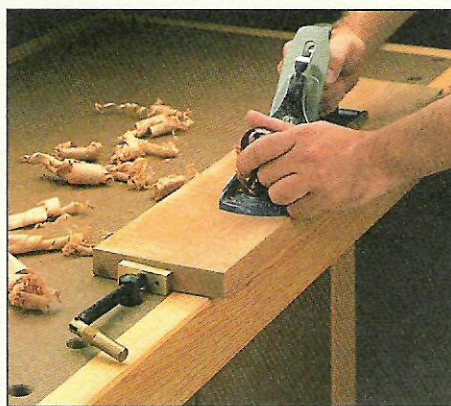

B. Bench Dog. A hex bolt (photo A) and a Veritas Wonder Dog make a functional bench dog system.

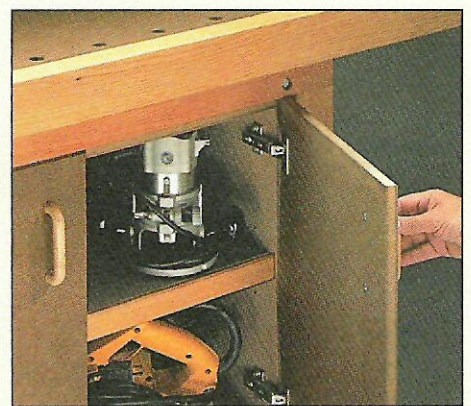

C. Cabinet. The cabinet is a convenient place to store hand tools. It also adds extra mass to the workbench.

EXPLODED VIEW
OVERALL DIMENSIONS"
36"H x 60"W x 24"D

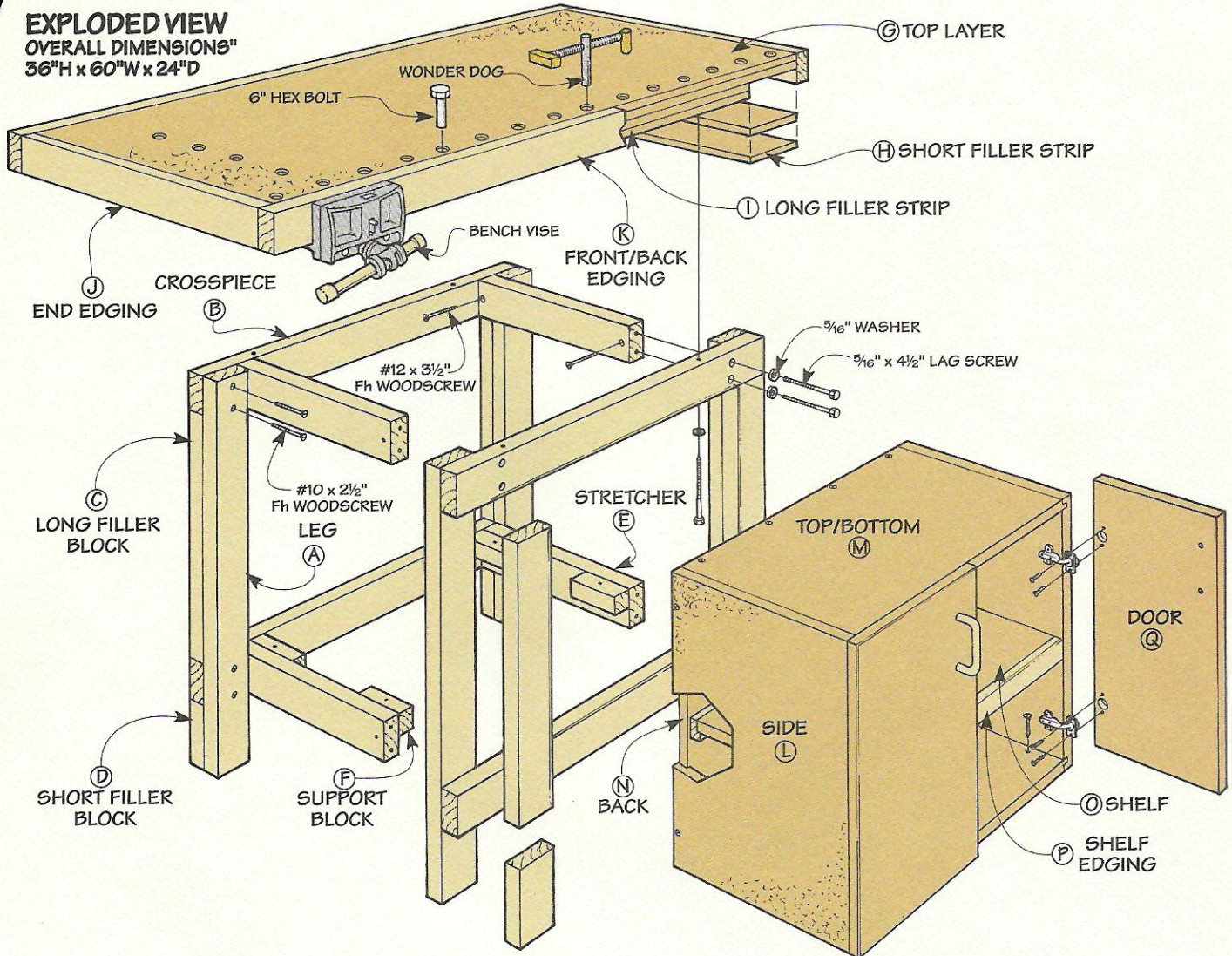

CROSS SECTION

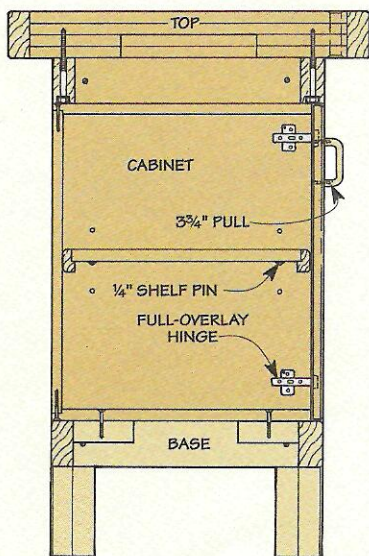

Materials & Hardware

- | | | |
|------------------------|-------------------------------|--------------------------------------|
| A Legs (4) | 1/2 x 3 - 33 | • (16) #10 x 2 1/2" Fh Woodscrews |
| B Crosspieces (4) | 1/2 x 3 - 36 | • (8) #12 x 3 1/2" Fh Woodscrews |
| C L. Filler Blocks (4) | 1/2 x 3 - 21 | • (20) 5/16" x 4 1/2" Lag Screws |
| D S. Filler Blocks (4) | 1/2 x 3 - 6 | • (20) 5/16" Flat Washers |
| E Stretchers (4) | 1/2 x 3 - 15 | • (18) #8 x 2" Fh Sht. Mtl. Screws |
| F Suppt. Blocks (4) | 1/2 x 1 1/2 - 4 | • (4) 1/4" Spoon-Type Shelf Pins |
| G Top Layers (2) | 3/4 x 21 - 57 MDF | • (4) Full-Overlay 125° Hinge Clips |
| H S. Filler Strips (4) | 3/4 x 6 - 21 MDF | • (4) Omm Hinge Mounting Plates |
| I L. Filler Strips (4) | 3/4 x 6 - 45 MDF | • (2) 3 3/4" Center-to-Center Pulls |
| J End Edging (2) | 1/2 x 3 - 21 | • (1) Bench Dog - 3/4" x 6" Hex Bolt |
| K Ft/Bk Edging (2) | 1/2 x 3 - 60 | • (1) Bench Vise |
| L Cabinet Sides (2) | 3/4 x 17 - 20 15/16 MDF | • (1) Wonder Dog |
| M Cab. Top/Bt. (2) | 3/4 x 17 - 28 15/16 MDF | |
| N Cab. Back (1) | 3/4 x 19 15/16 - 28 15/16 MDF | |
| O Shelf (1) | 3/4 x 15 - 28 5/16 MDF | |
| P Shelf Edging (2) | 1/2 x 3/4 - 28 5/16 | |
| Q Doors (2) | 3/4 x 14 7/8 - 20 7/8 MDF | |

For a hardware kit (Vise & Wonder Dog not included), call ShopNotes Project Supplies at 800-444-7527.

Kit No. 924-6824-200.....\$33.95

Base

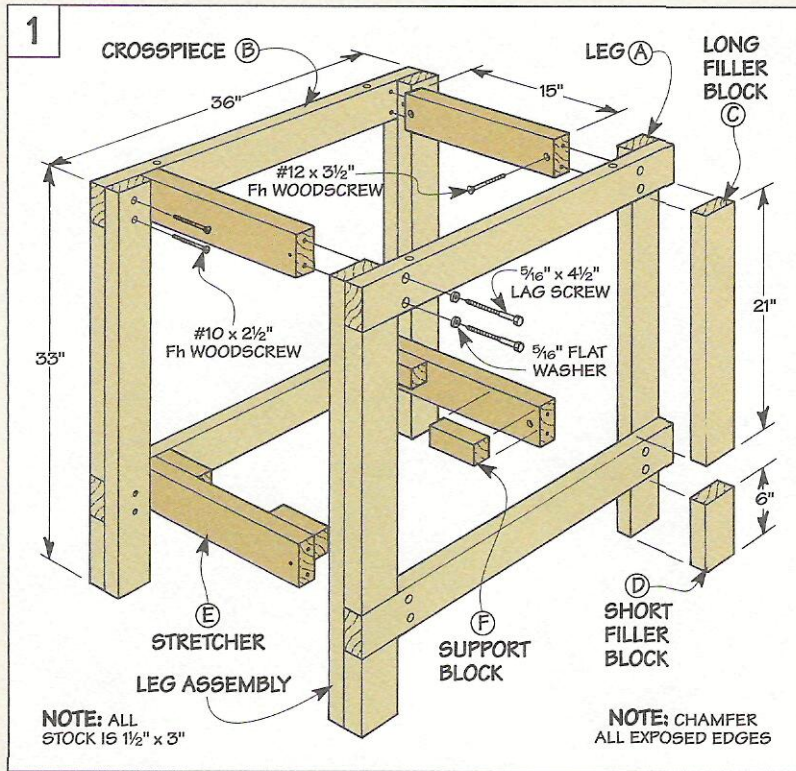

hold the top in place, see Fig. 2.)

To ensure a square assembly, it's important the legs and crosspieces are square to each other before gluing and screwing them together. It's also a good idea to check the distance (30") between the legs prior to screwing the assembly together — just to make sure you'll have the proper opening for the cabinet added later.

After the crosspieces are screwed to the legs, you could use the leg assemblies as they are. But to add extra support, *long filler blocks (C)* are cut to fit between the crosspieces and glued to the legs (A), see Fig. 1. Once they're in place, *short filler blocks (D)* can be added to the bottom of each leg in the same manner.

Now all that's left is to drill counterbored holes in the leg assemblies for the stretchers added next, see Fig. 2.

STRETCHERS. The leg assemblies are spanned by four *stretchers (E)*, see Fig. 1. After they're cut to size, you can assemble the base with lag screws, see Fig. 2.

SUPPORT BLOCKS. If you plan to build the storage cabinet, now's a good time to glue *support blocks (F)* to the bottom stretchers, see Fig. 3. Later, these provide a way to secure the cabinet to the base, refer to Fig. 9.

Although I designed this bench from the top down, I started by building the base. This way I have something to set the top on when I begin working on it.

The base consists of two main leg assemblies joined together by four short stretchers, see Fig. 1. Rather than use 3"-thick stock for the legs and then cut notches to create the joinery, the legs are pieced together from 1 1/2"-thick

Douglas Fir — the joinery is "built-up" as the parts are glued and screwed together.

LEG ASSEMBLIES. The first step is to make the two leg assemblies. Each consists of two *leg (A)* pieces that support the top and two *crosspieces (B)* that hold the legs (A) together, see Fig. 1. (Note: It's easiest to drill counterbored holes in the crosspieces now for lag screws used later to

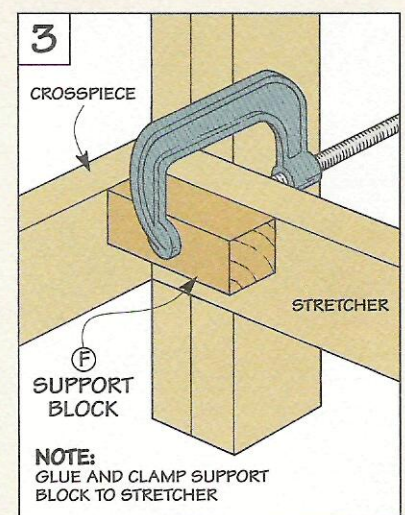
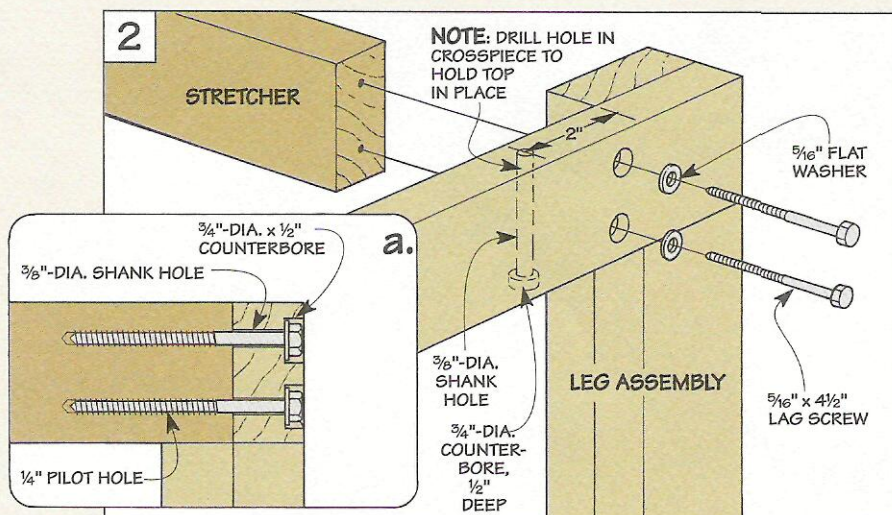

Top

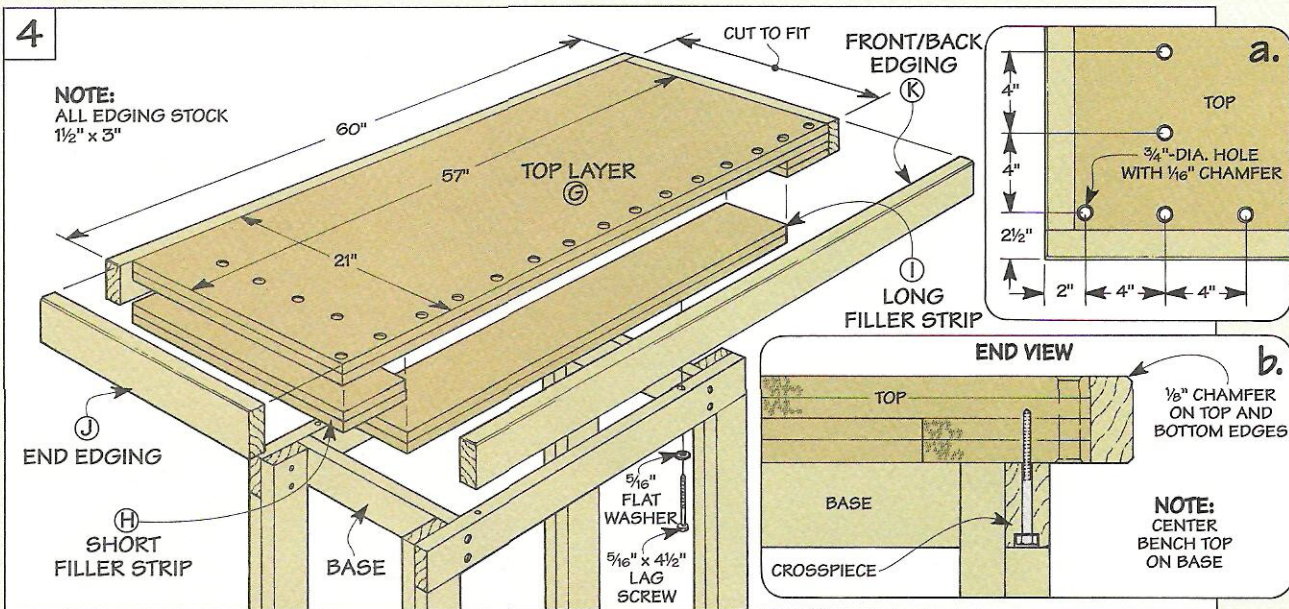

Once the base is complete, you can begin work on the top. The top consists of two full layers of MDF, two sets of 6"-wide MDF strips that run along the perimeter (on the bottom), and edging made of Douglas Fir, see Fig. 4.

LAYERS. The easiest way to build the top is to do it in layers. Start by cutting the *top layer* (G) to exact size, see Fig. 4. Next, cut a second *layer* (G) slightly oversized in both length and width and glue it to the bottom of the first layer. (I used contact cement.) Then use a flush trim bit in a hand-held router to cut it to match, see Figs. 5 and 5a.

Now the third and fourth layers can be added — one layer at a time. To do this, simply glue two *short* (H) and two *long* (I) *filler strips* to the previous layer, see Fig. 6. Note: When cutting the strips to width, be sure to allow for flush trimming, refer to Fig. 5a.

EDGING. Once the fourth layer is trimmed to size, the top is ready for protective fir edging that's glued in place. For best results, start with the *end edging* (J) pieces, see Fig. 4. Then cut the *front and back edging* (K) pieces to fit. Once the glue dries, soften

the sharp corners by routing a chamfer along the edges.

MOUNT TOP. Before mounting the top to the base, holes for bench dogs can be laid out and drilled, refer to Fig. 4a. Then to

make it easy to insert the bench dogs, chamfer the top and bottom edges, refer to Fig. 4a. (After the top is mounted to the base, a bench vise can be mounted to one end, refer to photo on page 16.)

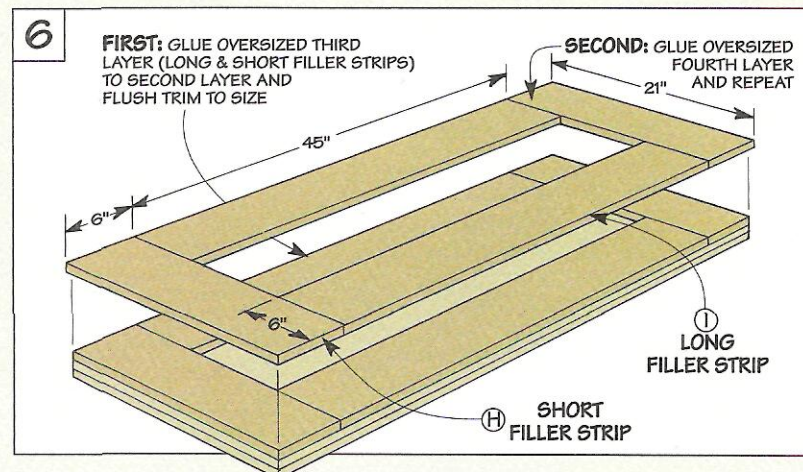
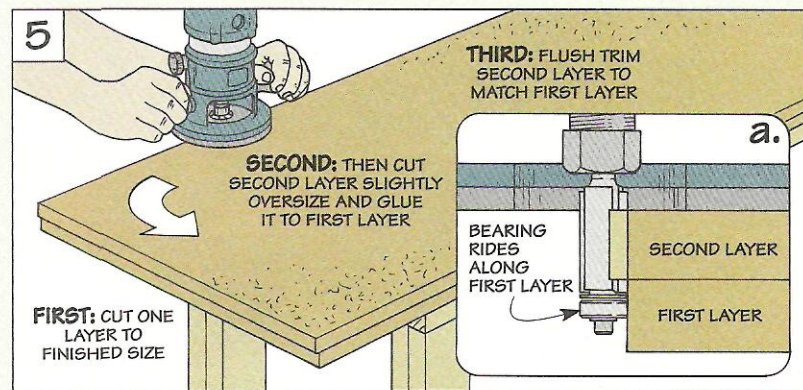

Case

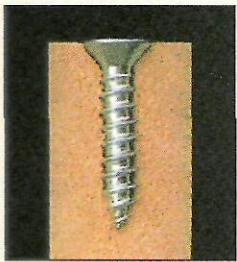
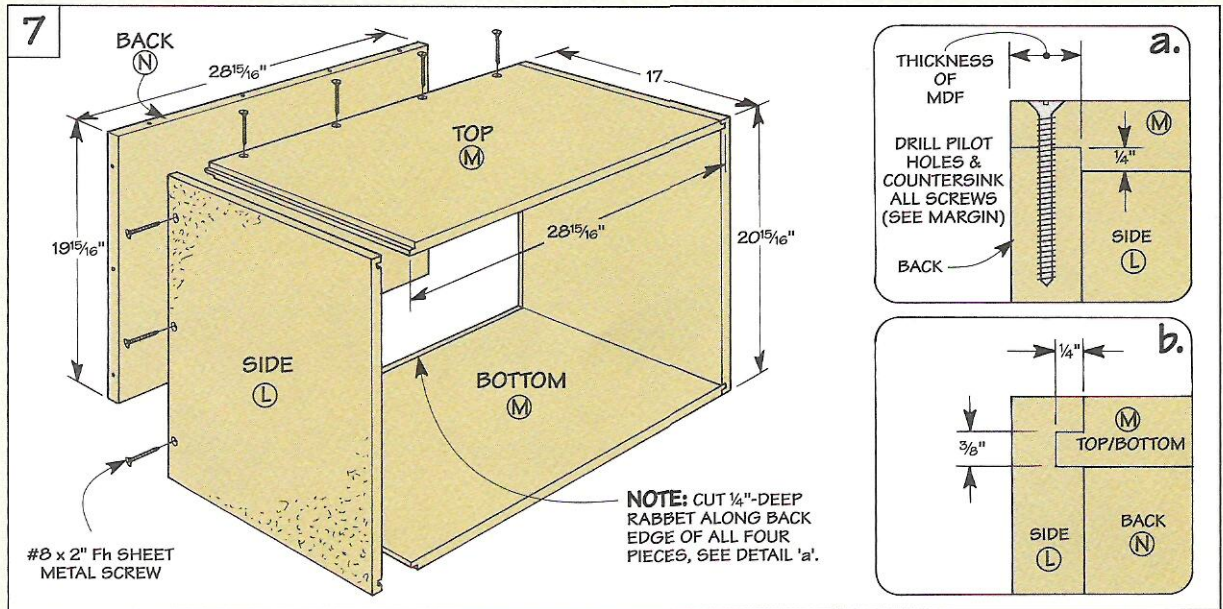

To avoid splitting MDF, drill pilot holes and use a screw with a straight shank.

Now you can turn your attention to the storage cabinet that fits in the base. Like the bench top, the cabinet is built from 3/4"-thick MDF. It's just a simple box with an adjustable shelf inside and two doors on the front, see Fig. 9.

BUILD TO FIT. To ensure the cabinet fits inside the base, it's a good idea to first measure the opening of the base and make a few calculations before actually cutting any parts.

For the height of the side (L) pieces, subtract a 1/16" from the height of the opening to allow for clearance between the cabinet and the top crosspiece (B), refer to Fig. 1 on page 18. (In my case the sides are 20 15/16" tall.)

Then measure the width of the opening for the length of the top and bottom (M) pieces and subtract 1 1/16" (28 15/16"). This allows for a 1/32" clearance between the sides of the cabinet and the base, and for the rabbet and groove joinery used to hold together the parts of the cabinet.

JOINERY. After the sides (L), top, and bottom (M) pieces were cut to size, I set up the table saw with a dado blade to cut the rabbet and groove joinery.

First grooves are cut in the sides (L), see Fig. 7b. Then a rabbet at both ends of the top and bottom (M) is cut to fit the grooves, see Fig. 7b. To complete the joinery, cut a 1/4"-deep rabbet along the back edge of all four pieces for a back (N) added next, see Fig. 7a.

After gluing the sides (L) to the top and bottom, cut a back (N) from 3/4"-thick MDF to fit, see Fig. 7. Then glue and screw it in place (countersinking all screws).

SHELF. Now you can cut a shelf (O) to fit the cabinet. When cutting it to length, allow for a 1/16" clearance at each end (1/8" total) for spoon-type shelf support pins, see Fig. 8. When cutting the shelf to width (depth), allow for the two edging (P) pieces that will help prevent the shelf from sagging over time, see Fig. 8.

Now shelf edging (P) can be added. (I used Douglas Fir.) They're cut to the same length as

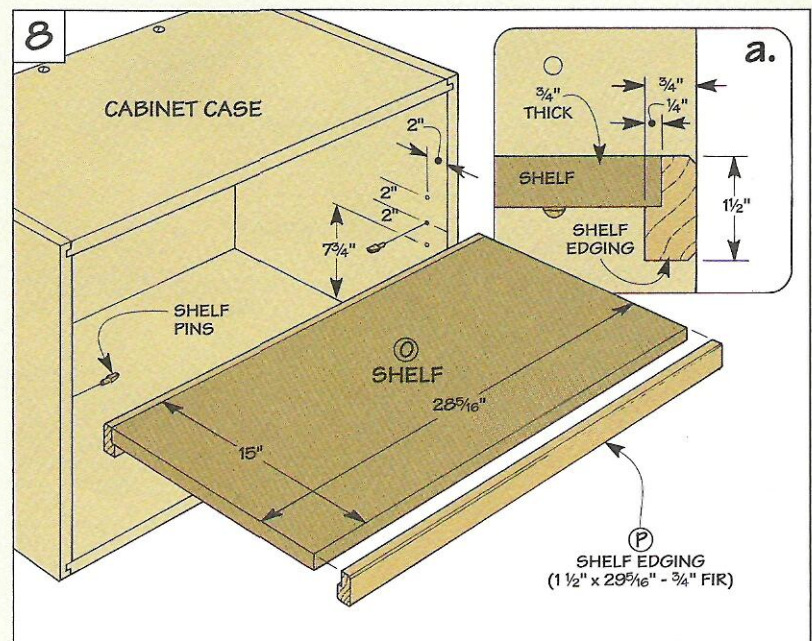

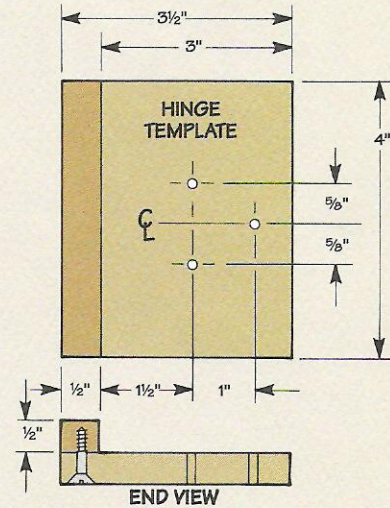
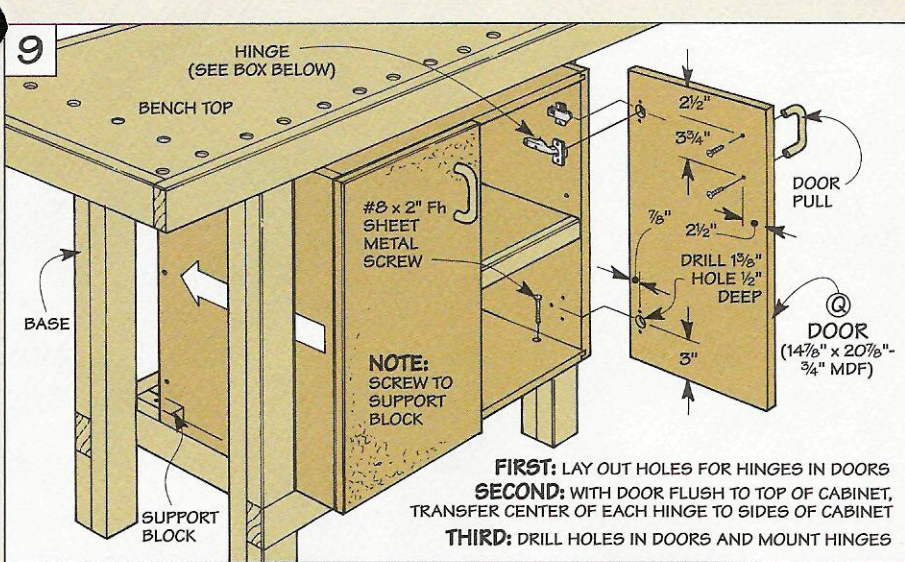

the shelf, with a rabbet cut on the inside edge to help support the shelf, see Fig. 8a. Once the edging (P) is glued in place, holes for the support pins can be drilled in the sides of the cabinet, see Fig. 8.

DOORS. Now the cabinet is ready for a pair of doors. To keep things simple, the doors (Q) are

mounted flush with the front of the cabinet, see Fig. 9

When cutting the doors to size, be sure to allow for a $\frac{1}{16}$ " gap at the bottom so they won't drag across the base when they're opened or closed. And a $\frac{1}{16}$ " gap between them for clearance. (In my case, the doors are 14 $\frac{7}{8}$ " x 20 $\frac{7}{8}$ ".)

Once the doors are mounted and the hinges adjusted (I used self-closing, European-style hinges, see box below and template detail above), door pulls can be added.

Then to complete the workbench, slide the storage cabinet in the base and screw it to the support blocks (F), see Fig. 9. 

Installing European Hinges

European-style hinges aren't your ordinary hinges. The hinge we selected (*blum*) has had a lot of engineering go into its design, see photo at right. It's a two-piece (mounting plate and hinge clip) quick-release

hinge, that swings a door open 125°.

It's a totally concealed, self closing hinge that's easy to install, see steps below. And once installed, the door (via the hinge) can be adjusted up or down, side to side, and front to back.

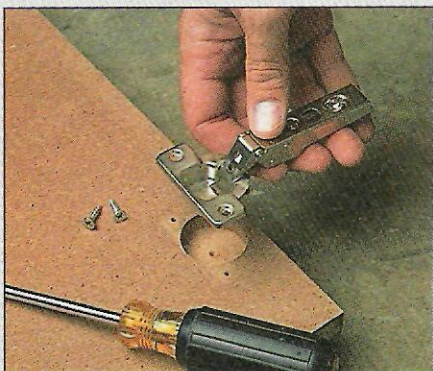

Step 1. To install a hinge, first drill a 1 $\frac{3}{8}$ "-dia. hole for the cup of the hinge clip and two pilot holes for the screws.

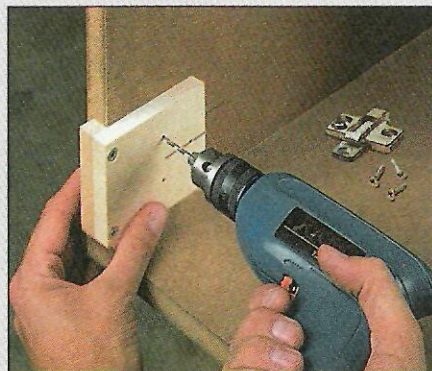

Step 2. Next, drill pilot holes in the side of the cabinet for the mounting plate screws, refer to template above.

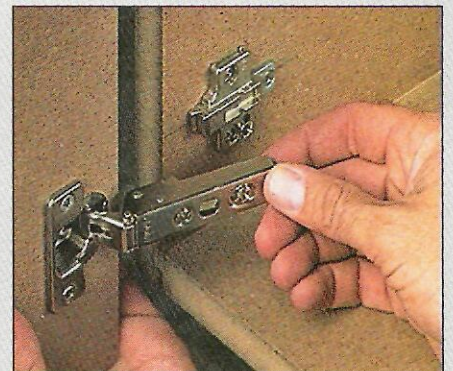

Step 3. To hang a door, just snap the hinge clip on the mounting plate, then adjust the hinges to position the door.

Band Saws

The thing that impresses me about a band saw is how easily it handles difficult jobs. Like resawing thick stock into thin boards. Or cutting curves and irregular-shaped pieces. You can even cut precision joinery with a good-quality band saw.

No matter what type of work you do, selecting the right band saw is an important decision. The only problem is there are dozens of saws to choose from. To help make that decision easier, we tested six medium-duty band saws, see photos and prices below.

CRITERIA. Besides the price, each saw had several things in common, see margin. By the way, the only thing that isn't reflected in the price is the shipping

charge. And that made a considerable difference in some cases, see the chart on the next page.

TEAM. Like our other tool tests, we rounded up three people with different woodworking experience to test each band saw.

Cary is just getting started in woodworking. *Steve* is an experienced woodworker and has used band saws extensively. And *Ken* is a professional carpenter and cabinetmaker.

Of course, with three people testing them, it's easy to end up with more than one "best" saw. But that's great if you're in the market for a saw. After consider-

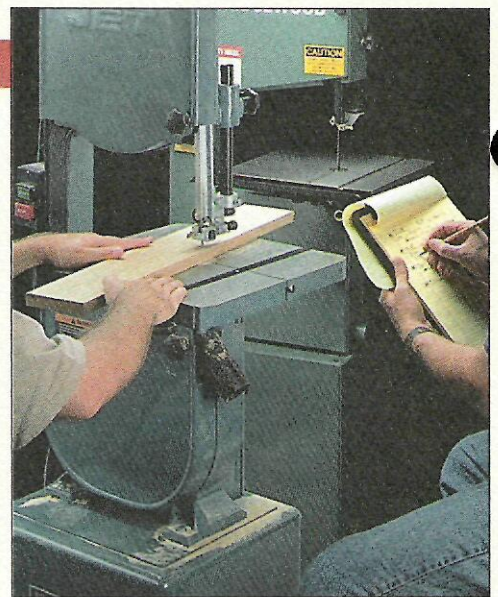

ing the type of work you plan to do, you can use one of the three different viewpoints to help steer you in the right direction.

BLADES. To keep the test on an equal footing, we installed new blades on each saw, see top photo on page 23. This ensured we tested the performance of the saws — not the blades. (For more on our test-

How We Selected the Saws

We tested all the medium-duty band saws that met the following criteria:

- 13" to 15" wheels
- 3/4 hp - 1 hp motor
- \$500 - \$800*

*At \$425, we also wanted to take a look at the Grizzly.



Bridgewood PBS-320
(800-235-2100)
\$659



Delta 28-283
(800-223-7278)
\$759



Grizzly G1148
(800-541-5537)
\$425



Jet WBS-14CS
(800-274-6848)
\$549

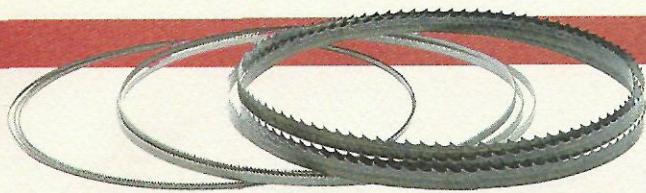

Blades. To produce reliable results, we installed new Lenox blades on each saw. These included an 1/8" blade for scroll cuts, a 1/4" blade for cutting curves, and a 1/2" blade for resawing.

ing procedures, refer to page 26.)

Finally, we asked the same person (Steve) to assemble each saw and talk about what he found.

Q: What were your overall impressions of the way the saws were packaged?

Steve: Except for one saw, they were all packaged very securely. But the Bridgewood was boxed up like a load of scrap metal.

This saw was stuck in an oversized (open) cardboard box with no packing around it. And the metal base was strapped on top with a band that held everything to a pallet. Fortunately, the only casualty was a bent tension rod

that I was able to straighten out.

Q: Did any parts get lost in the process?

Steve: Surprisingly, not one. And the saw went together without a hitch. In fact, along with the Jet, the Bridgewood was one of the quickest and easiest saws to assemble.

Q: What were you looking for as you assembled each saw?

Steve: One thing is how the wheels and guide system are supported. To provide an accurate cut, there has to be rock solid support. That's no small job when

Cost of Shipping

Delta, Jet, Powermatic
No Freight charge

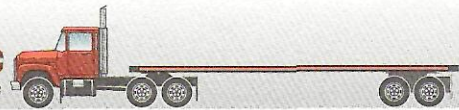

Bridgewood
\$55.20



Grizzly
\$66.86



Sears
\$215.95



you consider the tension placed on the wheels.

The Delta and Jet have a sturdy cast iron arm to keep the saws extremely rigid. (See photos below.) But the welded steel frames on the other saws are a mixed bag.

Of these saws, I liked the beefy frames on the Bridgewood, Sears, and Powermatic. But I'm a bit skeptical of the lighter gauge metal on the Grizzly saw.



Powermatic 43
(800-248-0144)
\$599.99

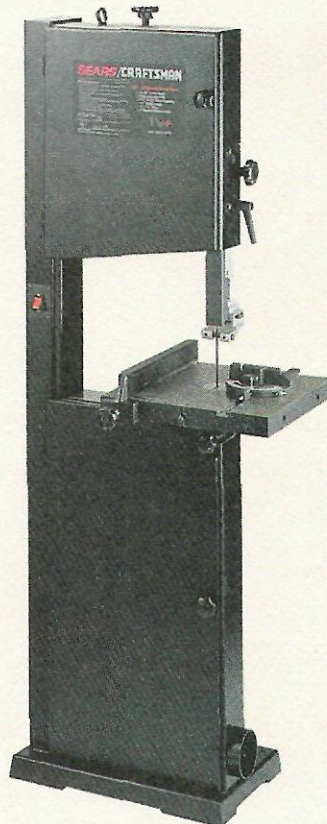

Sears 24393N
(800-290-1245)
\$699.99



◀ Cast Iron Arm.

To provide strength and rigidity, the Delta (shown) and the Jet band saws are supported by a sturdy, cast iron arm.

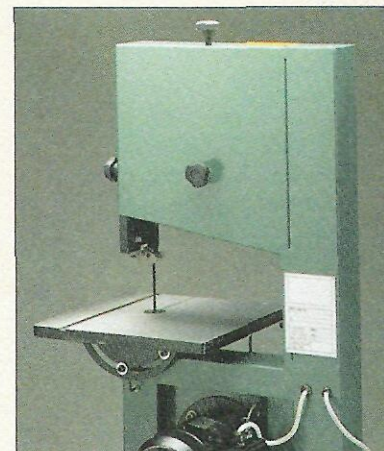

◀ Steel Frame.

The other saws are designed with a welded steel frame. The heavy gauge steel on the Bridgewood (shown), Sears, and Powermatic make them the sturdiest saws of this style.

Adjusting the Blade

Q: A blade that has the right tension is the first step to getting an accurate cut. Any problems applying blade tension?

Cary: The problem I had is knowing how much to crank the tension knob. Since there's no scale on the Sears, Grizzly, and Bridgewood, it's a guessing game.

Steve: Even though a scale isn't always accurate, at least it gives me a starting point. I particularly like how easy it is to read the bright orange indicator on the Delta scale. The scales on the Jet and Powermatic don't have an indicator, so they're not much use.

Ken: One thing that bugs me is having the tension assembly on the *inside* of the saw cabinet. (See photos above.) That can be a real finger-slicer when I spin the wheel to track the blade.

Q: How hard was it to get a blade to track evenly on these saws?

Cary: It took me awhile to get the hang of tracking a blade on the Grizzly. That's because instead of a singled threaded knob that tilts the top wheel in or out,

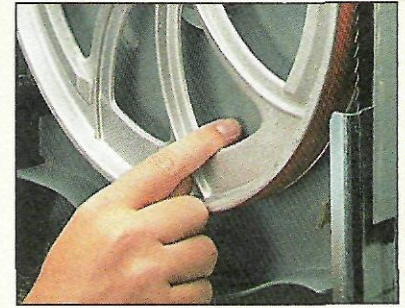
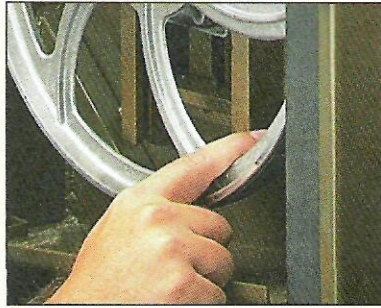

Finger Clearance. On steel frame saws like the Powermatic (left), the tension device is on the inside of the cabinet. So when tracking a blade, you're more likely to catch your finger than with the Delta (right) or Jet.

it has *two* separate adjustment knobs. (See drawings below.) So there's more trial and error getting both knobs adjusted just right.

Ken: Even so, it was easier for me to track a blade on the Grizzly than the Powermatic — especially with an 1/8" blade. It wandered all over the wheel when I tried to adjust the tracking.

Steve: I agree. Tracking an 1/8" blade is trickier than a wide blade. But overall, I was impressed with how quickly I could get different size blades on each saw to track right on the money.

Q: Getting a blade to track evenly is half the battle. What about the guide system that keeps it cutting in a straight line?

Cary: The thing I noticed right off the bat is there are two different types of guides to keep the blade from twisting side to side.

At first, I thought the bearings on the Powermatic would provide a more accurate cut. (See drawings on top of next page.) But once I got the guide blocks on the other saws adjusted just right, there wasn't any noticeable difference.

There is a difference in the guide blocks though. Several saws use a softer material which will end up requiring more maintenance. (See margin on page 25.)

Q: What about the thrust bearings that keep the blade from shifting back as you make a cut?

Ken: They all work fine — once they're adjusted. And some thrust bearings are considerably easier to adjust than others.

That's because the shafts that hold the bearings on the Delta (top center photo on next page), Jet, and Bridgewood are made of a hard metal. So they don't scar

Adjustment tools

- Jet**
box wrench
- Delta**
Allen wrench
- Grizzly**
Allen wrench, box wrench
- Powermatic**
Allen wrench, two box wrenches
- Bridgewood**
three Allen wrenches
- Sears**
Phillips screwdriver, two Allen wrenches, box wrench

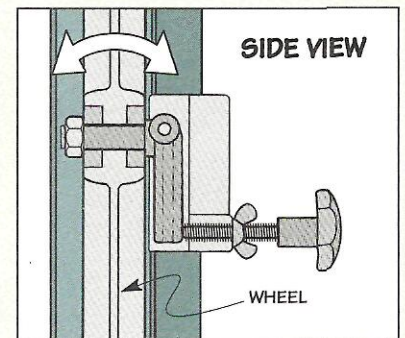
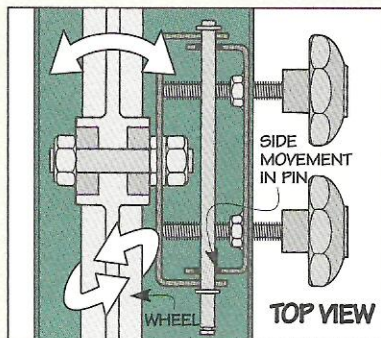

Tracking. The two tracking adjustment knobs on the Grizzly (left) tilt the wheel in two separate planes. So there's more "play" in the adjustment than with the other saws that tilt the wheel in one direction only.

when you tighten them down.

But with use, dimples form in the softer metal shafts of the Powermatic (bottom center photo), Grizzly, and Sears. So the shafts "creep" when I tighten them down. That's a pain when I'm shooting for 1/64" opening between the bearing and the blade.

Q: What else are you looking for in a guide system?

Ken: I change blades a lot, so I want a guide system that's quick and easy to adjust. That's why I liked the Jet. Except for removing the blade guard, you don't need a single tool to change a blade. Just loosen a thumbscrew to set the guide blocks. Then turn another thumbscrew to adjust the thrust bearings. (See chart on opposite page.)

Cary: Using an Allen wrench to loosen the guide blocks on the Delta isn't quite as handy. But once I set them from side to side, there's a knurled knob that lets me "micro-adjust" the guide blocks from front to back. Even the upper and lower thrust bearings are micro-adjustable.

Ken: With the Jet saw, only the upper guide blocks and thrust bearing are micro-adjustable. Besides not having a knob to fine tune the lower guide assembly,

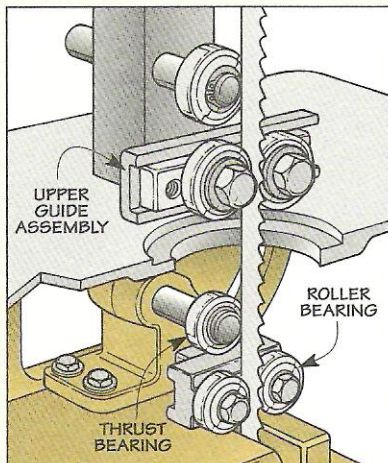

Bearings. Roller bearings on the Powermatic ride against the side of the blade to keep it from twisting.

it's not as close to the bottom of the table as the one on the Delta. So the guide blocks don't support the blade as well during a cut.

Q: How do the other guide assemblies stack up?

Steve: Compared to the Jet or Delta, setting the guide blocks and thrust bearings on the other saws is like going back to long division after you've used a calculator.

And not just because I have to fiddle with a bunch of wrenches. The guide assemblies (especially the ones below the table) are so hard to get at, trying to make an adjustment is a real circus act.

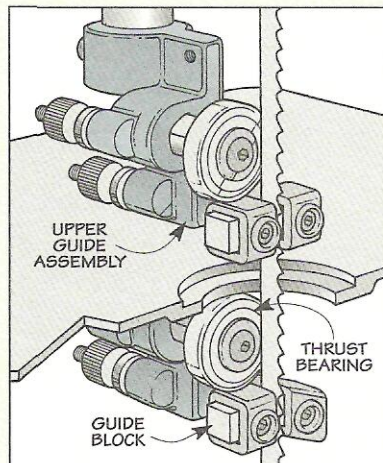

Blocks. The guide blocks on the other saws are set a hair from the blade. But they also prevent flex.

Q: Does raising or lowering the guide post affect the adjustments?

Steve: Not with the Bridge-wood, Powermatic, and Delta. These guide posts move straight up and down. So I didn't have to mess with the adjustments again. But changing the height of the guide post on the other saws threw off the adjustments just a bit.

Cary: Another thing I noticed is that some of the manufacturers "fudged" a bit on the maximum cutting height of the saw. (See chart.)

Steve: Besides the vertical adjustment, I also want the guide post to lock down square. (See photos below.) This way, it doesn't put a kink in the blade when I lock down the guide post.



▲ Soft, brass guide blocks on the Bridgewood need frequent resurfacing.

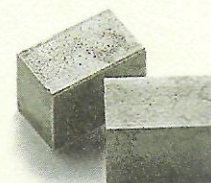

▲ But the hard metal of the Delta guide blocks won't scar as easily.



▲ Roller bearings on the Powermatic run a bit cooler without scoring.

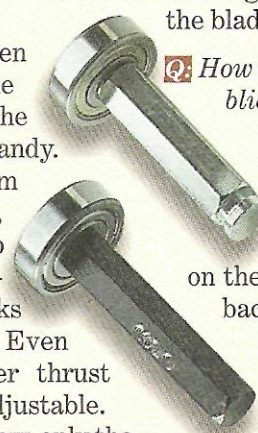

Cutting Capacity

	In Manual	Actual
Bridgewood	6 1/2"	6"
Grizzly	7 7/8"	7 1/2"
Jet	6"	5 3/4"
Delta	6 1/4"	6 1/4"
Powermatic	7"	7 1/4"
Sears	8 1/2"	8 1/2"

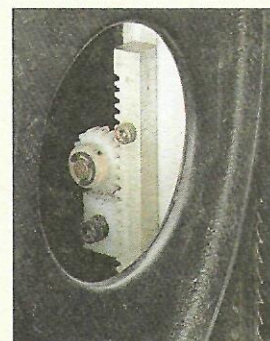
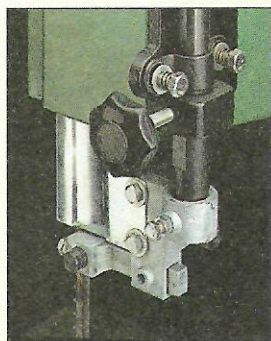

Guide Posts. The "flat" on the Grizzly guide post (left) and the keyed groove on the Jet (center) help them

lock square. But the rack and pinion system on the Sears guide post (right) makes it the smoothest to adjust.

Performance

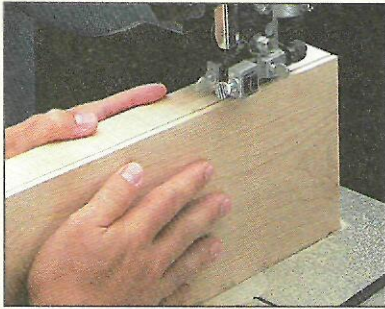

Resawing. After installing a 1/2" blade, we resawed hard maple at the maximum capacity of the saw.

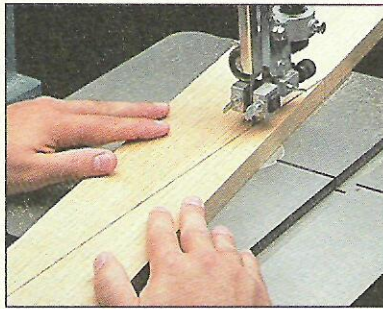

Shapes. Cutting irregular shapes and curves with a 1/4" blade showed how well the saw held to a line.

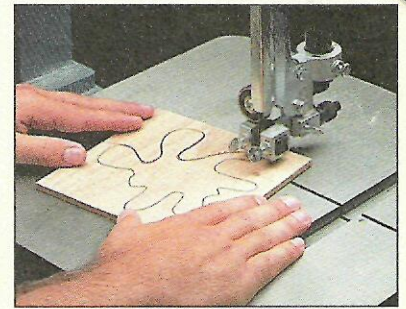

Scroll Cuts. And cutting tight curves with an 1/8" blade put the saw's guide system to the test.

Q: When it comes to a "muscle job" like resawing, how do these saws measure up?

Cary: One saw that particularly impressed me was the

Bridgewood. Even though the manual describes it as a "hobby saw," it slices through hard maple like a much heavier tool.

Steve: The Sears saw has that same solid feel — like it could cut all day long. Probably because both saws use heavy, cast iron wheels. (See photos below.)

Ken: But the saws with cast aluminum wheels were also able to resaw with no trouble. The Jet saw ran especially strong, and I was able to feed stock at a surprisingly fast clip. When I took a look under the hood, I found out why. Besides the Bridgewood, it's the only saw with a 1 hp motor. (All the rest have a 3/4 hp motor.)

Cary: That reminds me. The Bridgewood is also the only saw of the bunch that requires a 220-

volt outlet. So I'd have to run a new line to hook it up in my shop.

Q: What about the "bread and butter" cuts — cutting irregular shaped pieces and curved parts?

Ken: When cutting right up close to a line, it's hard to beat the accuracy of the Delta, Bridgewood, Jet, and Powermatic. And when it comes to making curved cuts, these saws handle like a sports car with a tight suspension.

But I couldn't make as controlled a cut with the Sears and Grizzly. Even though I adjusted the guide blocks carefully, the blade still wandered a bit during the cut.

Cary: That became even more of a problem when I made a scroll cut with the narrowest blade each saw can handle (3/16" on the Sears, and 1/8" on the Grizzly).

Direct Drive.

Connecting the spindle of the motor directly to the drive wheel produces a smooth running saw.

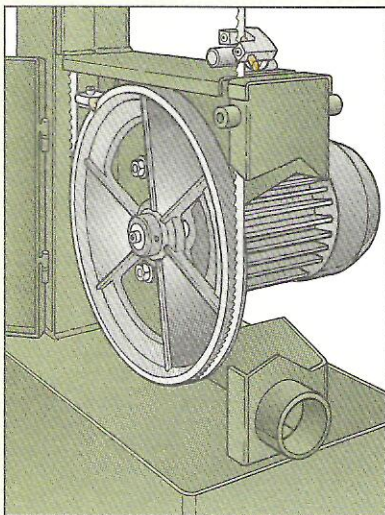

Belt Drive.

Using a belt to transfer power from the motor to the drive wheel sets up a small amount of vibration.

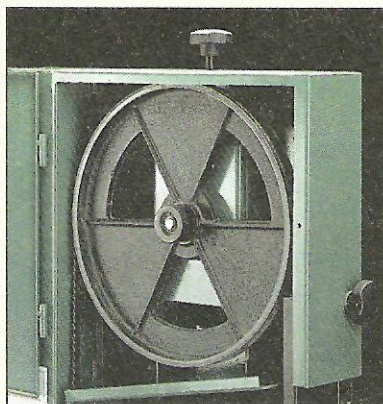
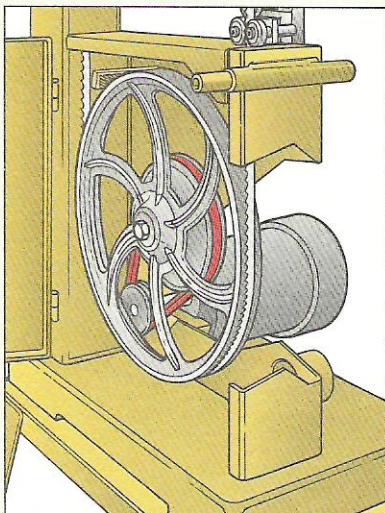

Wheels. The momentum set up by the cast iron wheel on the Bridgewood (left) produces a smooth cut. Although the aluminum wheel on the Delta (right) isn't as heavy, the spokes provide plenty of strength.

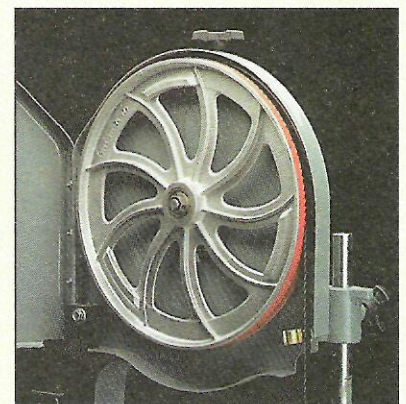

The flex in these blades made it harder to cut to a line. I also had some trouble getting a precise cut with an 1/8" blade on the Jet.

Q: The quality of cut is also affected by vibration. Do some saws run smoother than others?

Cary: The Bridgewood is so smooth, it's hard to tell whether it's running or not. That's probably because it's the only direct-drive saw of the bunch. (See drawings on page 26.)

But when they're tuned up, I found that the belt-driven saws ran smooth too. The only one that had a problem with vibration was the Powermatic.

With this saw, the nuts that held the stand together vibrated loose. And the table rattled and shook when I made a bevel cut.

Steve: The trunnion system that supports the table (and allows it to tilt) has a lot to do with

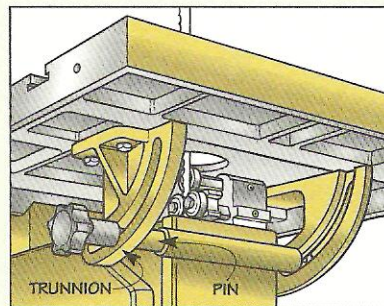
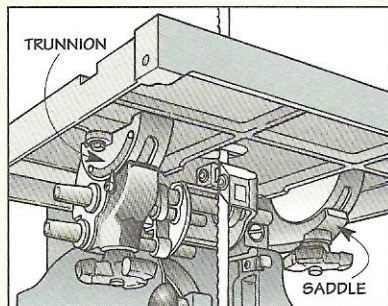

Trunnions. With the trunnions resting in a cast iron "saddle" (left), the tilting action of the table is smoother than if they're supported by a metal pin (right). And the table is rock solid when you lock it down.

that. The trunnions on the Grizzly, Jet, and Delta are cradled by a heavy, cast iron "saddle." (See drawings above.) So the table tilts smoothly — like you'd expect from a well-machined tool.

But the only support on the Powermatic is a metal pin that passes through slots in the trunnions. The play between the pin and the slots makes for a rough adjustment at best.

Q: Any other telltale indicators about the quality of the saws?

Ken: It's just a small thing. But I liked how the knobs on the Delta and Jet fit tightly into the spring steel clips inside the saw cabinet. (See photos below.) And since they don't come off in my hand like the knobs on the Powermatic, I'm not nearly as apt to lose them.

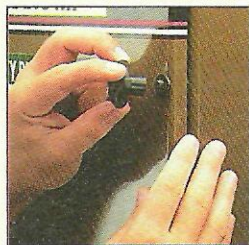
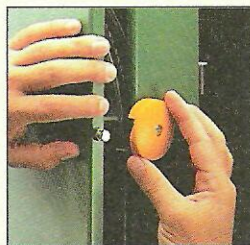
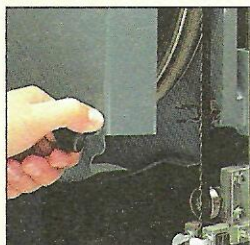

Knobs. The hard plastic knobs on the Jet (left) and the flimsy ones on the Grizzly (center) stay

on the cabinet when you open the door. But you have to unscrew the knobs on the Powermatic (left).



Recommendations

Cary: Picking the best band saw was a tough decision. That's because two saws consistently kept coming out on top — Delta and Jet.

But when it comes right down to it, the saw I'd want in my shop is the Delta. I like its heftier wheels and the guide post that slides perfectly straight up and down.

And since the lower guide assembly supports the blade closer to the bottom of the table, the Delta gave me a more accurate, controlled cut.

Steve: I chose the Jet for a number of reasons.

First, assembly is simple. The saw just bolts to the stand. And even though the manual is clear about setting up the saw, it ran well right out of the box.

Besides that, I liked the excellent fit and finish of the Jet. And it makes blade changing more convenient. Combine that with its strong running motor and this saw is a tough one to beat.

Ken: Adding a better blade guide system would make the Bridgewood an easy choice. But changing blades is too much of a nuisance.

So I picked the Jet. I can switch from one blade to another in minutes. And once the blade is mounted, that powerful motor can handle any job I expect to do.

Besides being a solid performer, the Jet is one of the least expensive saws we tested. For my money, it's a darn good buy. 🐿️

Shop Solutions

Mobile Stand

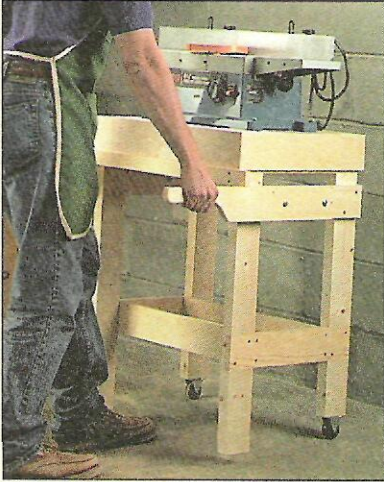

■ A wooden stand for a benchtop tool is an effective way to keep your workbench clear. But to make the most efficient use of your shop space, you need to be able to move the stand out of the way when it's not in use.

I got the idea to modify each of my tool stands and make them mobile from watching a gardener friend of mine use a wheelbarrow. Two simple add-on handles and a pair of casters are all it takes, see photo above.

To modify a tool stand, I started by shortening the rear legs just enough so a 2" caster

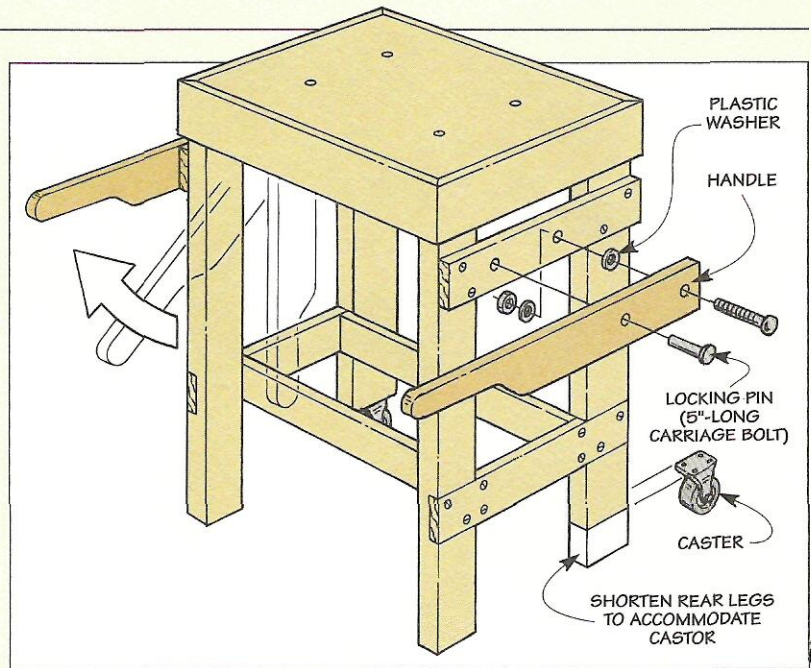

could be screwed to the bottom of each leg, see drawing. (The pair of casters I used cost around \$6 at my local hardware store.)

Then I bolted a pair of shop-made wheelbarrow-type handles (cut from a Fir 1by4) to the sides of the stand.

To make it so the handles can be easily lowered when not in use, it's a good idea to place a large plastic washer between each handle and the frame of the

stand — then loosely bolt the handles in place.

Finally, to lock the handles in the upright position and to provide the control necessary to roll the stand around the shop, I drilled a hole through each handle and through the frame to accept a locking pin. (The locking pin is just a $\frac{5}{16}$ " carriage bolt with the threaded end cut off.)

Hal Cooke

Johnson City, Tennessee

Tool Magnet

■ The tool holders for the tool cabinet shown in *ShopNotes* No. 22 work great. The only thing I've noticed is that my try squares tend to rattle against the door of the cabinet every time it's opened or closed.

To solve this, I use magnets. Just drill a hole in the end of each hanger to fit a $\frac{1}{2}$ "-dia. magnet, see drawing. Then epoxy a mag-

net in each hole. The magnets are strong enough to hold the blade of each square tightly in its hanger to prevent it from rattling against the door.

The magnets I used are available at most hardware stores and craft stores. (I paid \$1.50 for a package of five.)

Ivan James
Jacksonville, Illinois

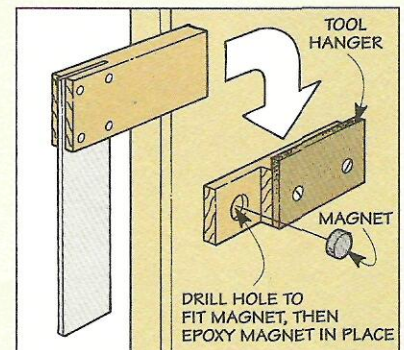

Magnetic Wrist Strap

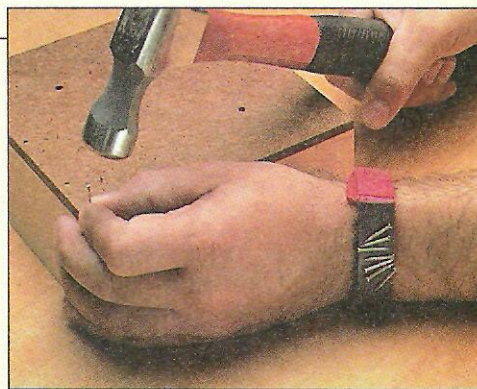
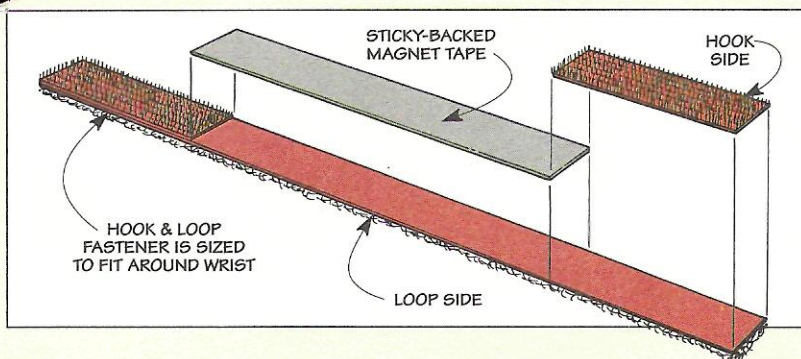

■ My workbench is the Bermuda Triangle for wire brads. All I have to do is set them down, and they disappear. To keep them away from my “brad-eating monster” and keep them within easy

reach, I use a shop-made magnetic wrist strap, see photo.

It's just a short length of sticky-backed magnet tape stuck to a length of hook and loop fastener that's sized to fit my wrist.

Hook and loop fastener and magnetic tape are available at most hardware stores. I spent about \$3.50 for my wrist strap.

*R.B. Himes
Vienna, Ohio*

Centering a Table Top

■ Centering the top on the base of a table used to be a time-consuming process for me. I'd spend a lot of time with a ruler checking and rechecking the overhang along all four sides to make sure it was the same all the way around. But now I've found a quicker, more accurate method.

First I flip the table top upside down and mark the center of all four sides, see drawing. Then I find the center of each apron, making a mark on the outside face of each apron where it meets the top. Once the centers are marked, place the base upside down on the table top.

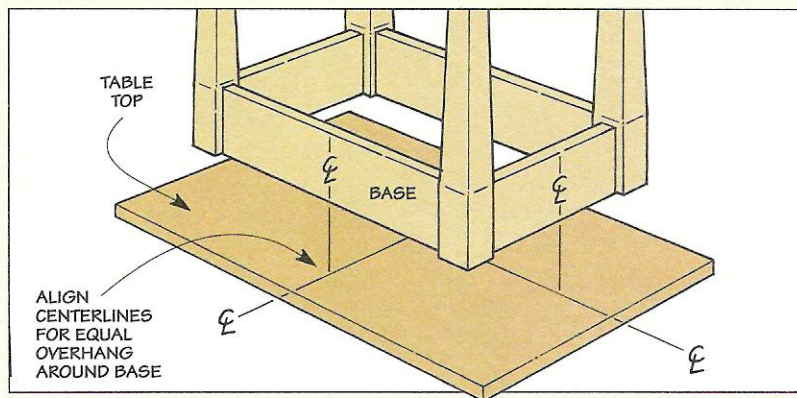

Now to center the base on the top, it's just a matter of aligning the marks on the aprons to the marks on the top. (Note: Before you tighten the mounting hard-

ware, double check the alignment marks one more time to make sure the base is centered.)

*Jim Debord
Spokane, Washington*

Quick Tips

■ I built the benchtop sanding table shown in *ShopNotes* No. 22 with one minor change.

To improve the “grip” of the top to hold a workpiece better, I used tempered pegboard that has one smooth side and one rough (textured) side, and I installed it with the rough side facing up.

*Monte Lane
Golden, Colorado*

■ To remove pitch from saw blades, I use Westley's *Bleche-Wite* whitewall tire cleaner. Just spray it on full strength. Then after a few minutes run water over the blade to rinse away the cleaner and pitch. It's available where automotive products are sold (\$4 for a 32oz. spray bottle).

*Paul Tranter
Marion, Iowa*

Send in Your Solutions

If you'd like to share your original solutions to problems you've faced, send them to: *ShopNotes*, Attn.: Shop Solutions, 2200 Grand Avenue, Des Moines, IA 50312. (Or if it's easier, FAX them to us at: 515-282-6741.)

We'll pay up to \$200 depending on the published length. Please include a daytime phone number so we can call you if we have any questions.

Softwood Plywood

I recently needed a high-quality softwood plywood. After checking with a local lumberyard, I could only find AC (underlayment), BC (utility), and CDX (exterior sheathing) grades. Is there a "cabinet-quality" grade of softwood plywood? And if so, where can I get some?

*Percy Johanson
Minot, North Dakota*

■ In years past, it was easy to find "cabinet-quality" softwood plywood at just about any lumberyard or home improvement center. But not any more. Today with the high cost of lumber, all they stock are "construction" grades. To find a higher grade, you'll need to do a little legwork.

GRADES. But before you do, it's a good idea to be familiar with softwood plywood grades. The most common are A, B, C, and D.

With the A and B grades, large knots are replaced with football-shaped patches, see photo A. Small knots and slight gaps are filled with a synthetic wood filler, see photo B. And voids along the edges are common, see photo C.

In the lower grades of plywood

(C and D), there's more patching and filling — even open gaps and defects are allowed.

For shop use, I'll generally stick with a BC (utility) grade of plywood (around \$23 for a ¾"-thick sheet). But if I'm building a piece of furniture, I move up to a higher-quality plywood.

HIGHER QUALITY. Here in Des Moines, I can buy quality, high-grade (AA and AB) softwood plywood at *Paxton Beautiful Woods* (a large, national lumber dealer

their next order (if you don't mind waiting for the shipment).

FACE VENEER. When you do find some, take a close look at it. I've noticed there's a wide range in quality. At *Paxton's*, I can buy two ¾"-thick sheets of AB plywood that are both produced by the *same* manufacturer.

One sheet has five plies with wild grain on the "A" face (\$46). Knots have been removed and patched. Other surface imperfections have been filled. And since the interior plies are a lower grade, there's a good chance the sheet will be riddled with voids.

The other sheet is a different product manufactured to a higher standard (\$48). Instead of five plies, there are seven. The grain and color on the "A" face is straighter and clearer. There are no knots or patches. And with high-quality interior plies, the sheet is free of voids.

A FINAL NOTE. Although you'll have to pay a few dollars more for this type of softwood plywood (and do some extra legwork to find it), it's well worth it. The extra effort will be obvious in your finished projects. 

The extra effort it'll take to find the higher grades of softwood plywood is well worth the effort.

with stores all over the U.S.). It's also available from a local lumberyard that caters to the professional cabinet shops in the area.

If you have trouble locating dealers like these, try looking in the yellow pages under cabinets and cabinetmakers, or under millwork shops. Then give them a call and ask where they're buying softwood plywood.

You may get lucky. They just might sell you a sheet from their stock. Or add what you need to



A. Patches. Large knots on A and B grades of softwood plywood are usually replaced with football-shaped patches.

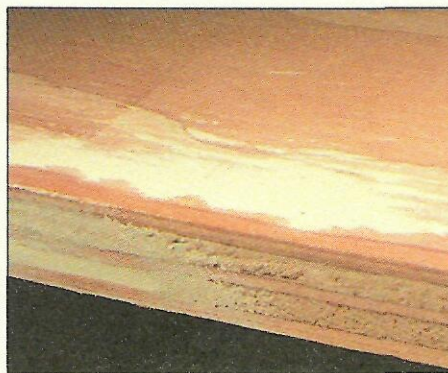

B. Filler. Small knots, gaps, and minor surface imperfections are generally filled with a synthetic wood filler.

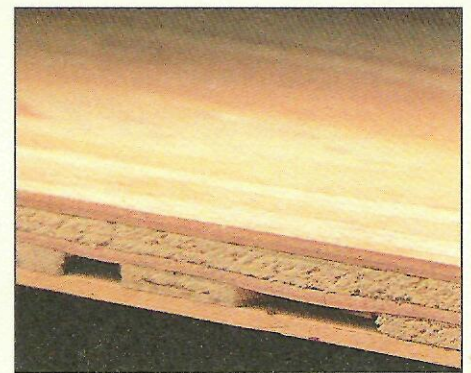

C. Voids. In addition to the face veneers, you can get a feel for the quality of the plywood by checking for voids.

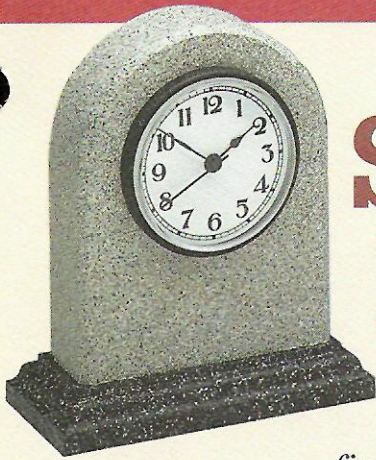

Specialty Finishes

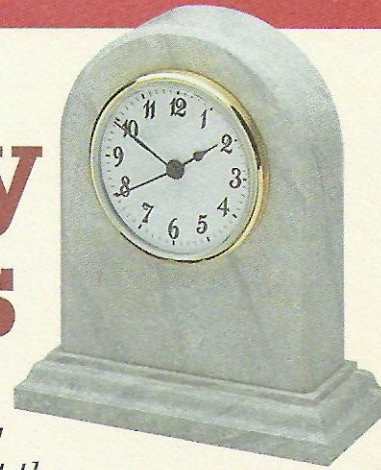

Here are two easy to apply finishes that can give a project the look and feel of stone or marble.

STONE FINISH

The easiest way to make a project look and feel like stone is to finish it with *Stone Craft* (made by Krylon). It's a two-step texturing product available in twelve colors.

The first step involves roughing up the surface followed by two coats of texturing paint, see photos. After the last coat dries, seal the finish with the acrylic topcoat that's included in each kit.

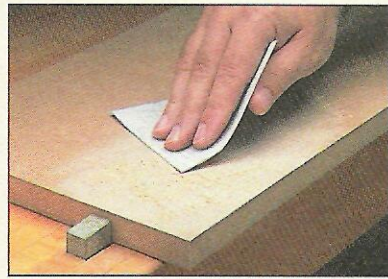

Step 1: To help the stone finish adhere better, rough up the surface with 100-grit sandpaper.

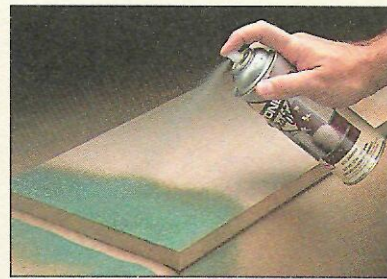

Step 2: Applying the stone finish is as simple as spraying paint from an aerosol can.

MARBLE FINISH

If you're after the look of marble, Plaid Enterprises makes a marbling kit (six colors available) that's fairly straightforward to use. It's a little more involved than applying the stone finish shown above, but it's well worth the effort.

Marbleizing a project with their kit involves layering on three different colors. The first two colors are mixed together and dabbed on with a sponge to produce a multi-colored base, see Steps 1 through 3. The final color, which is used to produce the veining common in most marble, is applied last with a feather, see Step 4.

And just like the stone finish, the manufacturer suggests that you seal and protect the marbleized finish with a coat of clear acrylic or polyurethane (not included in the kit). 



Step 1: To create the look of marble, a sponge with pieces removed is used to apply the basecoat.



Step 2: The basecoat colors are mixed together on a Styrofoam plate in the pattern of a pinwheel.



Step 3: To apply the basecoat, load the sponge, press it against the workpiece, lift, and repeat.



Step 4: Once the basecoat is dry, the veining color is applied separately with a feather.

Sources

The Krylon Stone Craft Finish and the Plaid Enterprises Marbleizing Kit are available at most hardware stores and wherever craft supplies are sold.

Scenes from the Shop

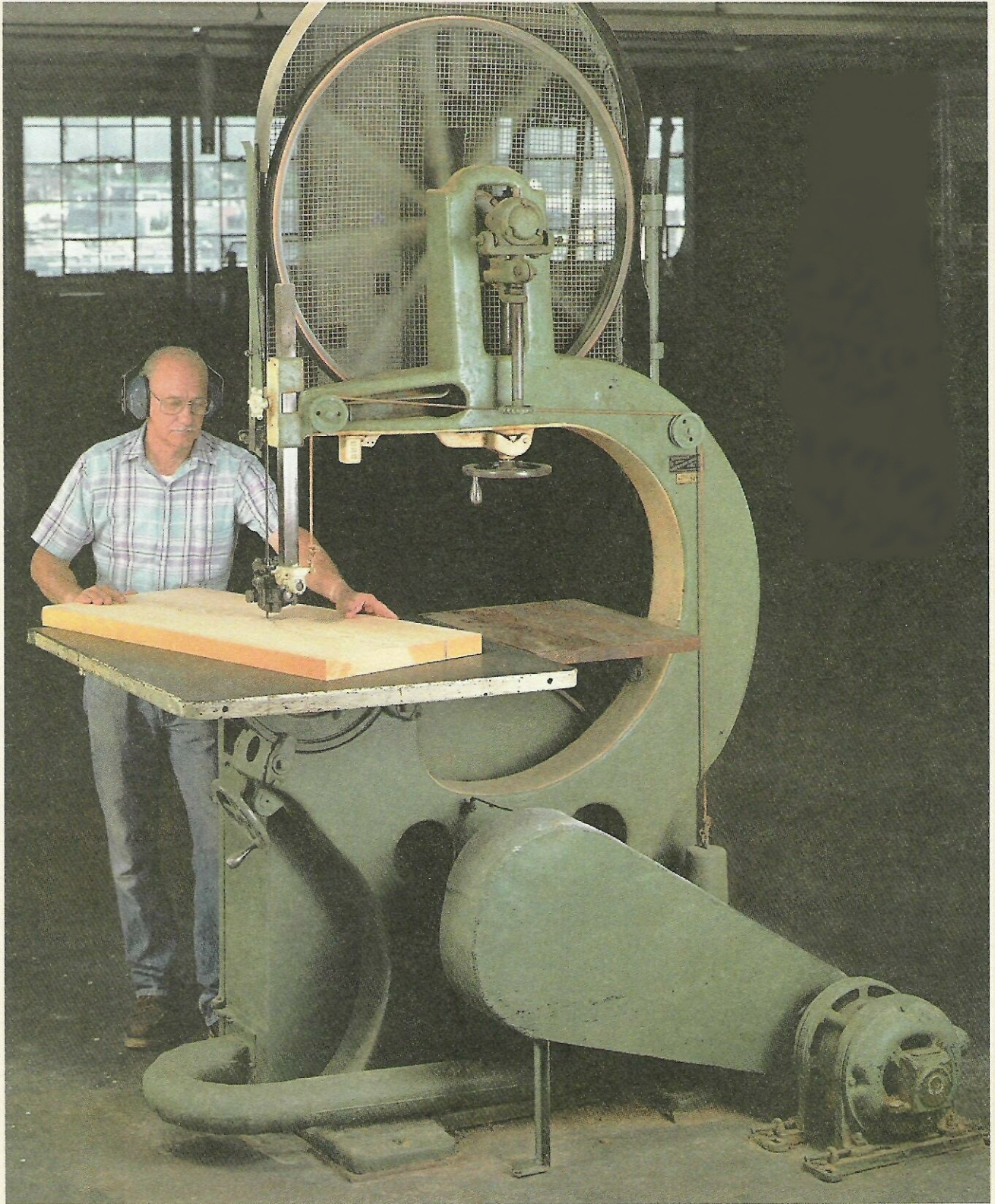

▲ Built in the 1950's by the American Woodworking Machine Co., this industrial band saw stands 9 feet tall. With 38½"-dia. cast iron wheels and a powerful

5 hp motor, it handles the big jobs. Mount a 1¾" blade and resaw timber up to 12" thick. Or take advantage of a 36" throat opening to cut extra-large workpieces.