

TIPS • TOOLS • TECHNIQUES

# ShopNotes®

Vol. 5

Issue 25

**SPECIAL TABLE SAW ISSUE!**



Build this  
**MOBILE  
CABINET**

for your Table Saw

- Table Saw Safety Switch
- Lighting in the Shop
- Combination Blades
- Cutting Angled Dadoes



# ShopNotes

Issue 25 January 1996

**PUBLISHER** Donald B. Peschke  
**EDITOR** Richard S. Peters  
**ASSOCIATE EDITORS** Tim Robertson  
 Phil Totten  
**ART DIRECTOR** Cary Christensen  
**SENIOR ILLUSTRATORS** Kurt Schultz  
 Roger Reiland  
 Mark Higdon

### CREATIVE RESOURCES

*Creative Director:* Ted Kralicek • *Exec. Editor:* Douglas L. Hicks • *Asst. Editor:* Vincent S. Ancona • *Project Design Dir.:* Ken Munkel • *Sr. Proj. Designer:* Kent Welsh • *Shop Manager:* Steve Curtis • *Shop Craftsman:* Steve Johnson • *Senior Photographer:* Crayola England • *Elec. Publishing:* Douglas M. Lidster • *Electronic Communication Coord.:* Gordon C. Gaippe • *Assoc. Graphic Design Dir.:* Susie Rider • *Senior Graphic Designer:* Chris Glowacki • *Graphic Designer:* Cheryl L. Cynor

### CIRCULATION

*Circulation Director:* Susan DuBois • *Assistant Circ. Dir.:* Troy Dowell • *Subscription Managers:* Sandy Baum, Paige Rogers • *Asst. Sub. Mgr.:* Julie Greenlee • *Newsstand Mgr.:* Kent A. Buckton

### CORPORATE SERVICES

*Vice President, Planning and Finance:* Jon MacCarthy • *Controller:* Robin Hutchinson • *Senior Acct.:* Laura Thomas • *Bkpr.:* Holly Lucas • *Production Dir.:* George Chmielarz • *Prod. Mgr.:* Carol Quijano • *Prof. Development Dir.:* Joyce Moore • *Net. Adm.:* Nick Thielen • *Admin. Assists.:* Cheryl Scott, Julia Fish • *Receptionist:* Jeanne Johnson • *Building Maint.:* Ken Griffith

### MAIL ORDER

*Operations Director:* Bob Baker • *Art Director:* Cindy Jackson • *Materials Mgr.:* Mark Mattussi • *Customer Service Mgr.:* Jennie Enos • *Warehouse Supervisor:* Nancy Johnson • *Buyer:* Linda Jones • *System Operator:* Tammy Aldini • *Team Leader:* Karla Cronin • *Tech. Support:* David Stone • *Cust. Service Reps.:* Jennifer Murphy, Joy Krause, Sara Kono, Anna Cox, Adam Best, Kristi Andrews, Margo Petrus • *Warehouse:* Gloria Sheehan, Chuck Carlson, Sylvia Carey, Larry Prine, Scott Gilliam, Cathy Steiner

ShopNotes® (ISSN 1062-9696) is published bimonthly (Jan., March, May, July, Sept., Nov.) by August Home Publishing, 2200 Grand Ave., Des Moines, IA 50312. ShopNotes® is a registered trademark of August Home Pub. ©Copyright 1996 by August Home Publishing. All rights reserved.

**Subscriptions:** Single Copy, \$4.99. One year subscription (6 issues), \$19.95. Two years (12 issues), \$35.95. Canada/Foreign, add \$5.00 per year.

**Second Class Postage Paid** at Des Moines, IA and at additional offices.

**Postmaster:** Send change of address to ShopNotes, Box 11204, Des Moines, IA 50340-1204

**Subscription Questions?** Call 1-800-333-5854, Sam to 5pm, Central Time, weekdays. FAX 515-283-5854

**E-Mail:** Prodigy: EDJE97A, CompuServe: 75330,2301, Internet: 75330.2301@compuserve.com, America Online: Shopnotes.

## WoodNet

### COMPUTER BULLETIN BOARD FOR WOODWORKERS

- Project plans and photos to download
- Woodworking Techniques Forum
- Indexes for Woodsmith & ShopNotes
- First month FREE for PC or MAC

To log on to WoodNet, call 1-515-245-9663. If you have any questions, please give us a call: (voice) 1-515-282-7000 M-F 9-5 CST.

## EDITOR'S NOTE

# Cutoffs

I've always had a problem calling my shop a "workshop." The dictionary defines a workshop as "an area, room, or establishment in which manual or industrial work is done." Well, they're not talking about my shop — I can't remember the last time I worked while I was there. It's just too enjoyable to call work. Sure, I can accomplish a lot in a day. Maybe build a project or two. But work? I don't think so.

**A THEORY.** I have a theory about this. I think it's an unspoken agreement between woodworkers. We call it a workshop so it sounds like a place where it's all work and no play. After all, if friends or family realized what a good time we were having, they'd want to join us. And this could disturb the solitude so many of us look forward to.

That's not to say an occasional visitor isn't welcome. It's always a pleasure to talk to a fellow enthusiast about "working" with wood. But for me, the best time in the shop is when I'm alone. There's nothing quite as comforting as the quiet "shushing" of a plane as it glides across a panel. Or that satisfying feel of a tight joint as it snaps together.

**MAINTENANCE.** Sometimes, I don't build anything. Instead, I spend time

making sure my tools are performing at their peak. Whether it's adjusting a favorite plane, or giving my table saw a good "once-over," it's very rewarding. And the tools run smoother and with greater accuracy. (For an article on how to tune up your table saw, see page 6.)

**SPECIAL ISSUE.** With the amount of time most of us spend at a table saw, we decided to devote most of this issue to projects and techniques to help you get the most out of this "workhorse." Besides the tune-up article mentioned above, there's a knee switch that belongs in every shop (page 4), a mobile cabinet with some nifty features (page 16), and even a look at popular saw blades (page 24).

**INDEX.** We've also been "tuning up" things here at ShopNotes. We've just finished an index of projects and information for issues 1-23, and issues 1-100 of Woodsmith. The price of the index is \$4.95 and includes shipping and handling. To order, you can call us at 800-444-7002, fax us at 515-283-0447, or write to us at P.O. Box 842, Des Moines, IA 50304. We'll send it right out to you. 🐿

Rick

### STATEMENT OF OWNERSHIP, MANAGEMENT AND CIRCULATION (Required by 39 U.S.C. 3685)

1. Publication Title: ShopNotes. 2. Publication No.: 1062-9696. 3. Filing Date: September 6, 1995. 4. Issue Frequency: Bimonthly. 5. No. of issues published annually: 6 (six). 6. Annual subscription price: \$19.95. 7. Complete mailing address of known office of publication: 2200 Grand Avenue, Des Moines, (Polk County), Iowa 50312-5306. 8. Complete mailing address of the headquarters or general business offices of the publisher: 2200 Grand Avenue, Des Moines (Polk County), Iowa 50312-5306. 9. Full names and complete mailing addresses of publisher, editor, and managing editor: Publisher: Donald B. Peschke, 2200 Grand Avenue, Des Moines, Iowa 50312; Editor: Richard S. Peters, 2200 Grand Avenue, Des Moines, Iowa 50312. 10. Owner: August Home Publishing Company, 2200 Grand Avenue, Des Moines, Iowa 50312; Donald B. Peschke, 2200 Grand Avenue, Des Moines, Iowa 50312. 11. Known bondholders, mortgagees, and other security holders owning 1 percent or more of total amount of bonds, mortgages or other securities: None. 12. (Does not apply.) 13. Publication Name: ShopNotes 14. Issue Date for Circulation Data Below: September 1995 15. Extent and nature of circulation:

	Average no. copies each issue during preceding 12 months	Actual no. copies of single issue published nearest to filing date
A. Total no. copies printed (net press run) .....	250,335	245,857
B. Paid and/or requested circulation:		
1. Sales through dealers, street vendors and counter sales .....	23,237	50,631
2. Mail subscriptions (paid and/or requested) .....	181,774	177,270
C. Total paid and/or requested circulation .....	205,011	227,901
D. Free distribution by mail, samples, complimentary, and other free copies .....	61	56
E. Free distribution outside the mail (carriers or other means) .....	0	0
F. Total free distribution .....	61	56
G. Total distribution .....	205,072	227,957
H. Copies not distributed:		
1. Office use, left over, unaccounted, spoiled after printing .....	13,042	14,018
2. Returns from news agents .....	32,221	3,882
I. Total .....	250,335	245,857
Percentage paid and/or requested circulation .....	99.97%	99.98%
16. This statement of ownership will be printed in No. 25, the January 1996 issue of this publication.		
17. I certify that the statements made by me above are correct and complete. (signed) Donald B. Peschke, Publisher		

# Contents

## Projects & Techniques

### Table Saw Knee Switch \_\_\_\_\_ 4

*With this knee-operated switch, you'll never again have to grope blindly for the power switch on your saw.*

### Table Saw Tune-up \_\_\_\_\_ 6

*A finely-tuned table saw not only does a better job of cutting wood. It's safer and more enjoyable to use too.*

### Utility Ladder \_\_\_\_\_ 10

*Here's a folding step ladder that won't wobble, is strong enough for two people, and has a tray for holding tools.*

### Angled Dadoes \_\_\_\_\_ 12

*Cut perfectly-aligned angled dadoes on the table saw using our simple technique and a shop-made jig.*

### Table Saw Cabinet \_\_\_\_\_ 16

*Extra Storage. A bin to collect dust. And an outfeed support. Three reasons to build this sturdy saw cabinet.*

## Departments

### The Small Shop Lighting in the Shop \_\_\_\_\_ 22

*Practical solutions for shedding light in your shop.*

### Great Tips Hardware Tips \_\_\_\_\_ 14

*A collection of five trouble-free tips to make your next hardware installation go quickly and easily.*

### Selecting Tools Combination Blades \_\_\_\_\_ 24

*Looking for the best saw blade? Our three-man team tests six combination blades and two general-purpose blades.*

### Readers' Tips Shop Solutions \_\_\_\_\_ 28

*Five of our readers offer their own shop-tested solutions to everyday woodworking problems.*

### Finish Room Rubbing out a Finish \_\_\_\_\_ 30

*The secret to a perfect finish isn't how you apply it. It's what you do after the finish dries.*

### Lumberyard Specialty Plywoods \_\_\_\_\_ 31

*Three unique plywood products for special projects.*

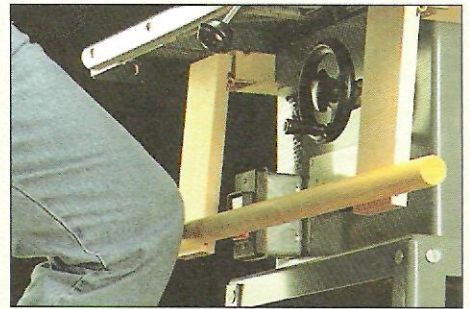

Knee Switch 4



Utility Ladder 10

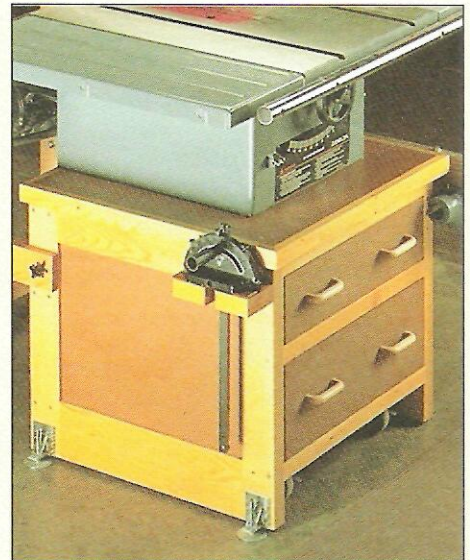

Table Saw Cabinet 16



Combination Blades 24

# Table Saw Knee Switch

You can turn off power safely and still keep both hands on your workpiece.

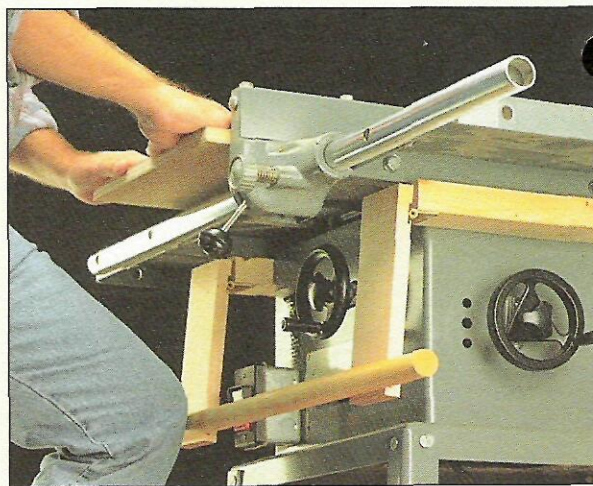

**Y**ou're in the middle of a rip cut when the motor starts to bog down. The wood begins to smoke. Then the blade binds up. Sound familiar?

Your first reaction is to reach for the power switch. But then you realize it could be difficult (and

dangerous) to control the workpiece with one hand while groping for the switch with the other.

Recently I faced this very situation. Fortunately, someone else was in the shop to turn off the motor for me. Once the dust settled, I decided right then and

there that I didn't want this to ever happen again. The result is this simple knee-operated shut-off switch, see photo above.

**LARGE BAR.** The shut-off switch is basically a large bar that rests against the OFF button of the saw's ON/OFF switch. (If your saw doesn't have a switch like this, see the box on the opposite page.) The bar hangs from a pair of arms and support brackets on the sides of the saw cabinet like a swing.

To use the shut-off switch, just kick or lean a knee into the bar. A plunger on the bar presses the OFF button to kill power to the motor. Or if you prefer, you can even use your hands, see bottom left photo on page 5.

## SUPPORT BRACKETS

Because the knee switch is designed to fit your saw, the first thing you'll need to do is determine the size of the two *support brackets* (A) the bar hangs from. (They're just lengths of 2x4.)

To do this, measure from the back of your saw cabinet to the front edge of the box the ON/OFF switch is housed in, see Figs. 1 and 1a. Then subtract  $\frac{3}{4}$ " to allow for the arms added later.

Once the support brackets are cut to length, they can be mounted to the cabinet. To do this, drill three holes through the cabinet to fit #8 x  $1\frac{1}{2}$ " woodscrews and screw them in place, see Fig. 1.

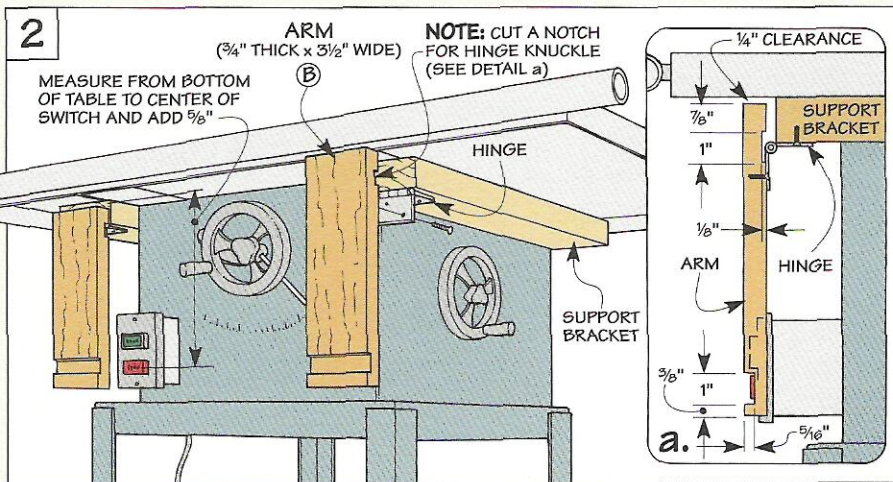
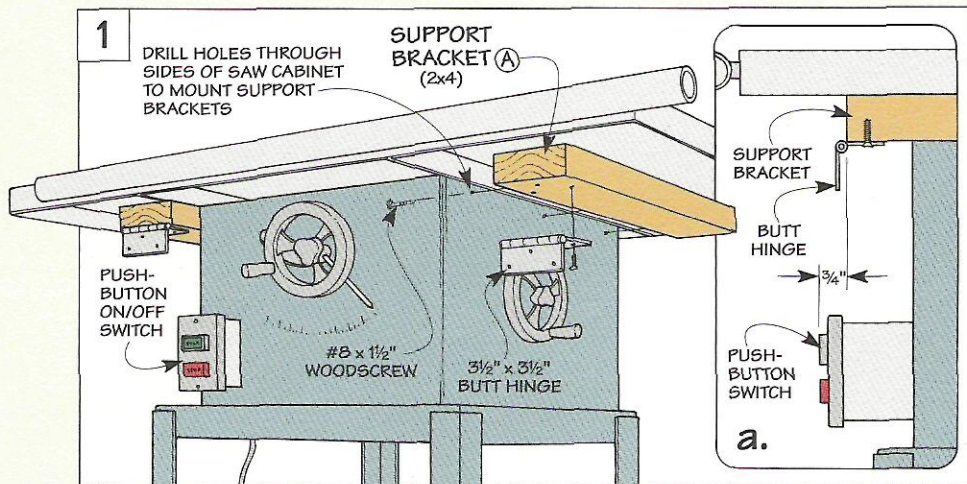

With the brackets in place, the next step is to screw a butt hinge to the end of each support, see Fig. 1. These hinges allow the knee switch to swing.

**ARMS**

Now you're ready to move on to the U-shaped knee bar that's made up of two arms and a bar.

To determine the length of the arms (B), just measure from the bottom of the table top to the center of the OFF button, see Fig. 2. Then add 5/8" for a dado that's added next.

Once the arms are cut to size (I used 3/4"-thick hard maple), a dado is cut on each side of the arm — one allows clearance for the hinge knuckle, the other accepts the bar, see Fig. 2a.

When screwing the hinges to the arms, leave a 1/4" clearance on top so the arms can swing freely, see Fig. 2a. After you've screwed them in place, all that's left is to add the bar.

**BAR**

The bar (C) hangs from the arms and runs across the full width of the table saw. The bar is just a length of 1 1/4"-dia. dowel with a plunger (a 1/2"-dia. dowel) glued in it to make contact with the OFF button, refer to Fig. 4.

To determine the length of

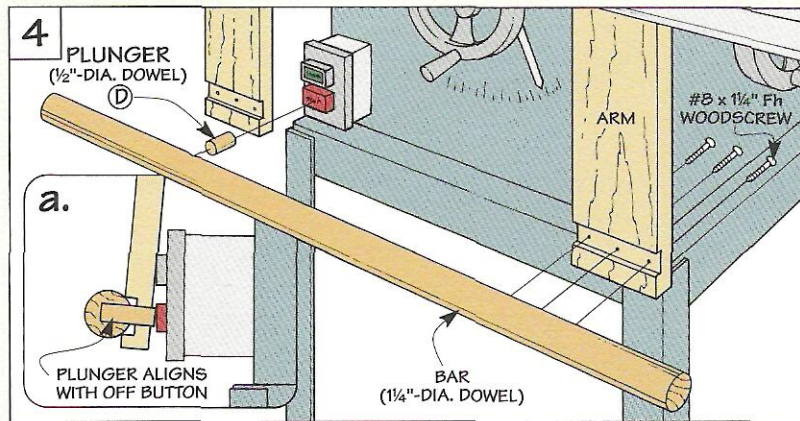
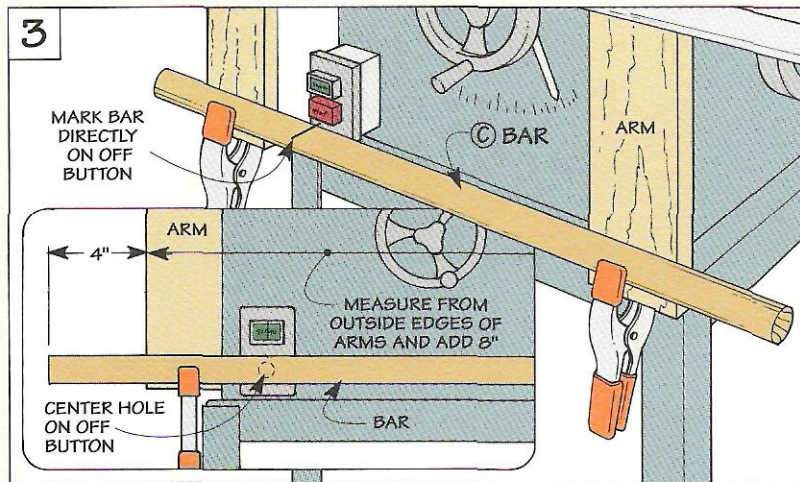

your bar (C), measure from the outside edges of the arms and add 8" for a 4" overhang at each end, see Fig. 3a.

Then to locate the hole for the plunger (D), temporarily clamp the bar to the arms, see Fig. 3. And make a mark on the bar

where it's directly over the OFF button, see Figs. 3 and 3a. Now drill a hole and add the plunger.

Finally, to mount the bar, I again clamped it in place with the plunger positioned over the OFF button, then screwed the arms to the bar, see Fig. 4 and 4a.

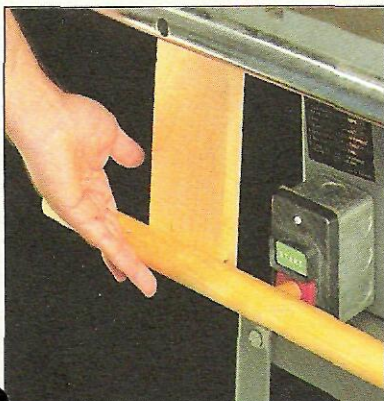

**Hand Operated.** The shut-off bar is designed to be knee operated, but you can also use your hand.

**Push-button Switch**

Many table saws come with toggle-type power switches. If your saw has one, you'll have to replace it with a push-button switch before you can build and use the knee switch, see photo.

Push-button switches are available through most electrical supply dealers. Some tool manufacturers even carry them. But check around. We found prices ranging from \$30 to \$130.



**Push-Button.** To build the knee bar, you'll need a pushbutton switch like this.

# Table Saw Tune-Up

*All it takes to keep a table saw in top condition is a little periodic maintenance and upkeep.*

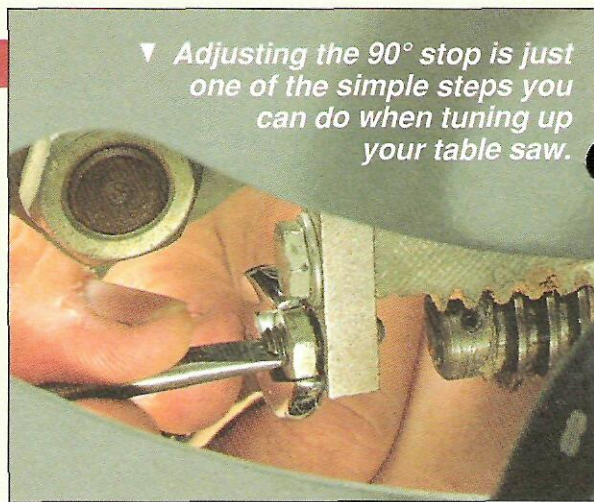

▼ Adjusting the 90° stop is just one of the simple steps you can do when tuning up your table saw.

**J**ust like any automobile, a table saw requires periodic maintenance and upkeep to keep it performing at its best. If kept clean, adjusted, and lubricated, a table saw will not only last longer, it'll also cut smoother and

with greater precision.

When it comes to routine maintenance on the table saw, I always do an in-depth tune-up once a year. And periodically throughout the year, I'll give the saw a quick checkup — just to make

sure everything is adjusted right and running smooth.

The following steps are what I recommend for a complete table saw tune-up. But for routine checkups, I only do the steps that are necessary.

## Cleaning

Keeping your table saw clean, especially the trunnion, is the single most important step to a well-maintained saw. (The trunnion is located under the table top, refer to top drawing on next page.)

If sawdust, pitch, and resin are allowed to build up here it won't be long before wormdrives, gears, and cranks become difficult to operate when tilting, raising, or lowering the blade.

**SAWDUST.** To clean the saw, the first thing I do is use an air compressor or shop-vacuum to blow off sawdust trapped in and around the trunnion, below the

table top, and inside the saw cabinet, see bottom left drawing.

**SOLVENT.** Once the sawdust is out of the way, I go right to work on the trunnion with a toothbrush and solvent to scrub away the pitch and resin build-up, see bottom right drawing and margin tip.

Turpentine and mineral spirits work well here. As does paint thinner. In fact, just about any solvent you have in the shop will loosen the build-up to help get the job done. (Note: Avoid lacquer thinner because it can strip paint from metal.)

**BRUSHES.** For stubborn build-up, it may be necessary for you to

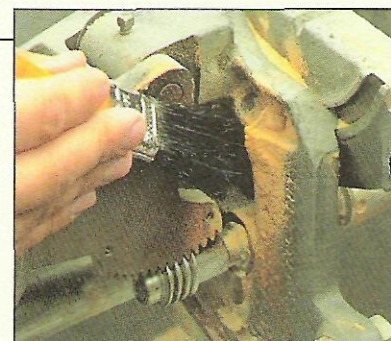

*It may be necessary to soak pitch and resin build-up with solvent to help break it free.*

saturate it with solvent and let it set a while. And if it's really stubborn and difficult to remove, try breaking it free with a brass or wire brush.

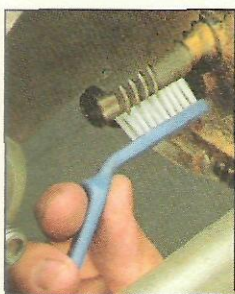

*To get at hard to reach places, heat the handle of a toothbrush and bend it at an angle.*

◀ Just about any solvent you have in the shop will work to help break up pitch and resin build-up.

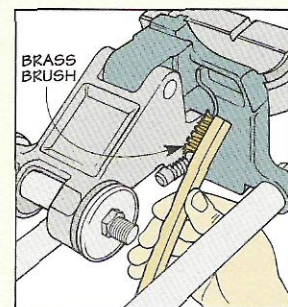
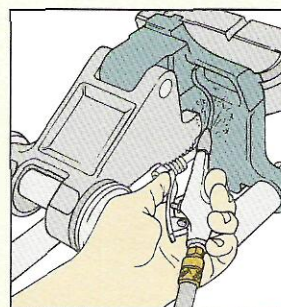

**Clean Saw.** To clean a table saw, the first step is to blow away any trapped sawdust from inside the saw cabinet. Then scrub away the pitch and resin build-up.

# Inspection

Once the saw is clean, my next step is to perform a complete visual and manual inspection.

**VISUAL INSPECTION.** To visually inspect a saw, I do it just like I do the engine of my car before taking it on a long trip.

The first thing is to look for (and jot down) any obvious problems — broken, bent, or loose parts, damaged gear teeth, and worn belts, see drawing.

**MANUAL INSPECTION.** Then I manually inspect the arbor for run-out and bearing problems, see Fig. 1. To do this, just remove the drive belt and give the arbor a few good spins.

As it's spinning, listen and feel for any problems. If you have a bearing problem, you should be able to hear or feel it.

If you do, it may be necessary to remove the arbor housing and have a new set of bearings installed. If it wobbles back and forth, it's probably bent and more than likely needs to be replaced.

After inspection, reinstall the belt and check the arbor and motor pulley alignment, see Fig. 2.

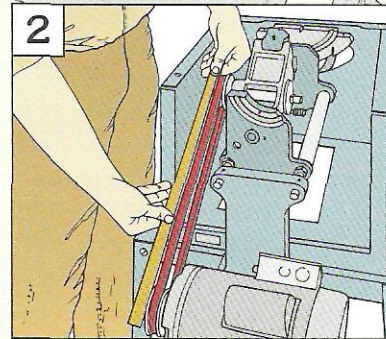
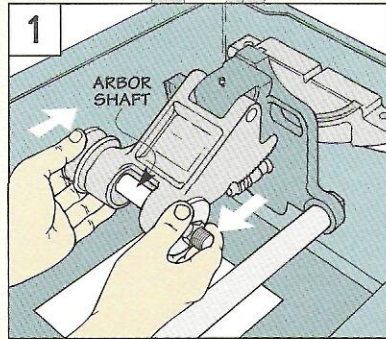
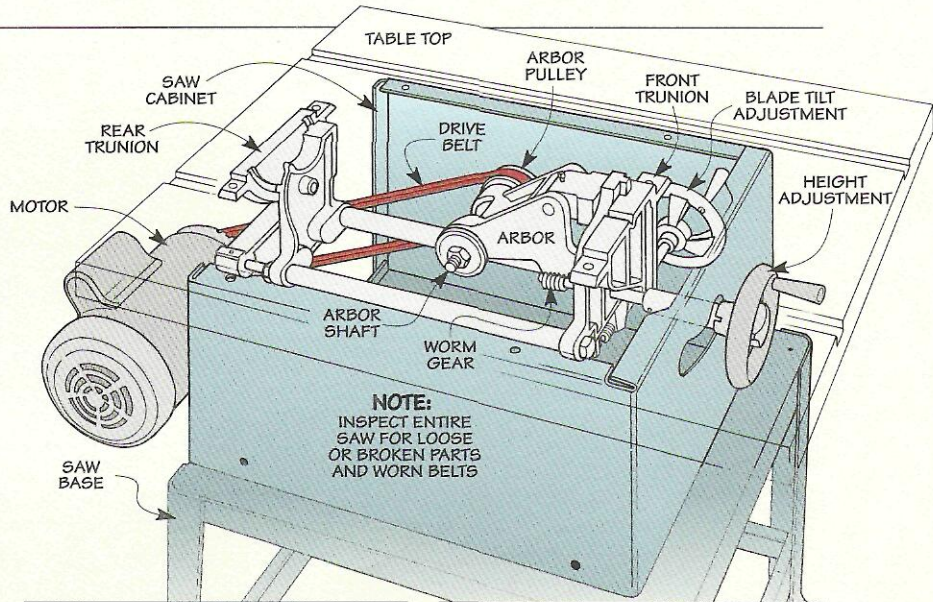

▲ To inspect the bearings in an arbor, first spin the arbor shaft, then try moving it back and forth.

▲ A straightedge is a quick and easy way to check the arbor and motor pulley alignment.

## Checking Trunnion Alignment

A quick way to check the alignment of the trunnion is to use a simple shop-made, T-shaped jig with a brass screw at one end, see photo at right.

Just place the jig in one of the miter gauge slots, near the front of the blade, see Fig. 1. Then adjust the

screw until it touches a tooth (mark this tooth). To check the alignment, simply slide the jig to the back of the blade and rotate the blade until the marked tooth faces the screw.

If the screw touches the blade, the trunnion is okay. If it doesn't touch (or

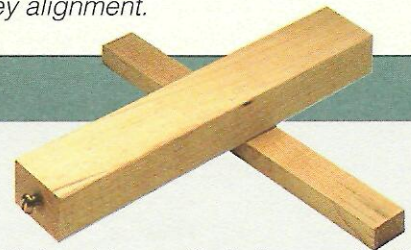

binds up) loosen the bolts securing the trunnion to the top, see Fig. 2. Then make the necessary adjustments, see Fig. 3 and your owner's manual.

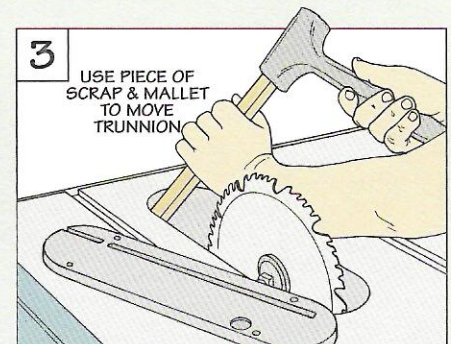
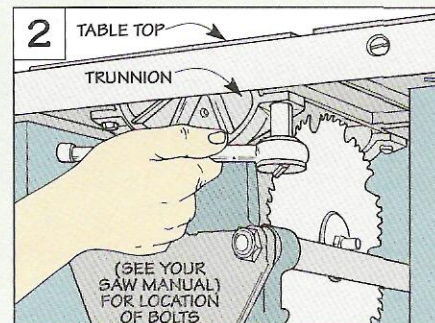
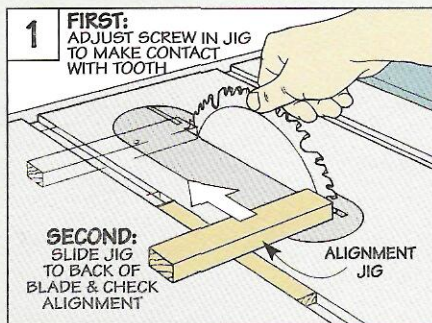

# Adjusting the Stops

On most saws, the 45° and 90° stops are only useful for getting you close to an angle. That's why I only use them as a rough guide and then take the time to set the angle with a triangle or square.

**CHECK STOPS.** To reduce the amount of hand cranking when changing angles, it's a good idea to periodically check the stops. Depending on your saw, you may have two stops (45° and 90°), one stop (90°), or none at all, see drawing. And the way each is calibrated may vary as well. Some saws have an adjustable collet around a worm gear, see detail a. Others use a set screw, see detail b. I've even seen one that has you bend a metal pointer to match up with a printed scale.

If you're not sure which type your saw has, or how to adjust it, check your owner's manual.

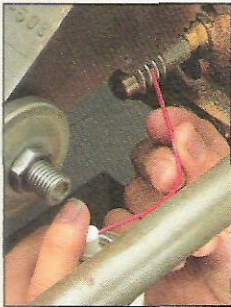
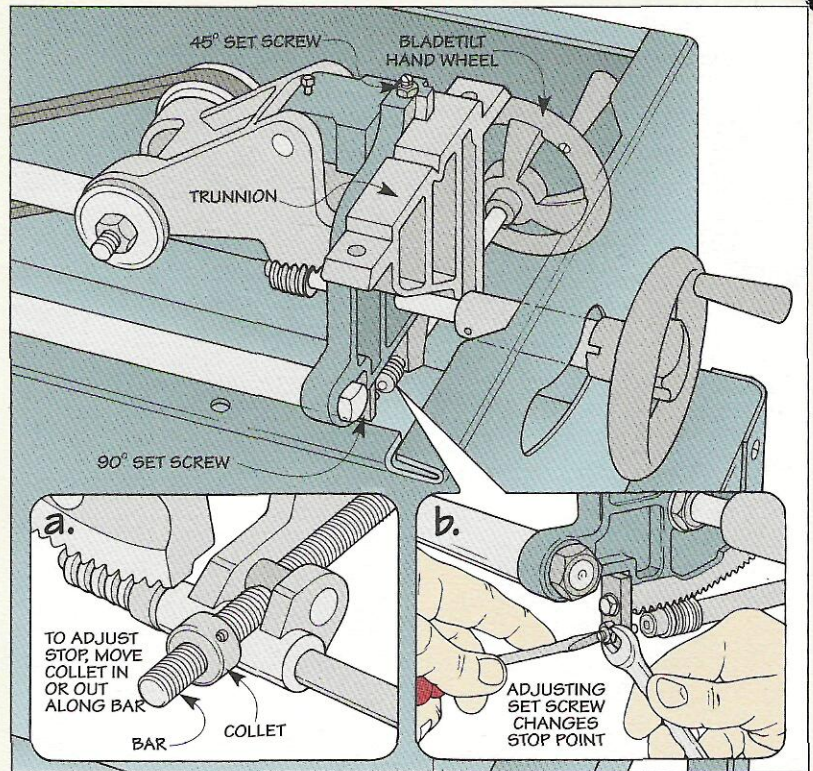

A recycled spray nozzle can help direct an aerosol solvent into a hard to reach place.

# Lubrication

Since sawdust constantly collects around the trunnion, the last thing you'll want to use as a lubricant here is a petroleum product. (If you do, it won't take long for parts to cake up and become difficult to operate.)

To lubricate moving parts with minimal build-up, I use

paraffin wax (any type of hard paste wax will do) or graphite powder, see bottom left photo.

Also, avoid applying lubrication near sealed bearings. All this will do is attract and retain more sawdust — which could penetrate and cause the bearings to seize.

When applying wax

or graphite, use only what's necessary to keep the parts moving freely, see drawing below.

You'll find that paraffin wax lasts longer. But you'll have more build-up sooner. Graphite powder on the other hand doesn't increase build-up, but you'll have to apply it more regularly.



◀ To prevent pitch, resin, and sawdust from building up, I use paraffin wax or graphite powder. For table saws exposed to low temperatures (such as one stored in a garage), try lubricating internal moving parts with white Lithium grease.

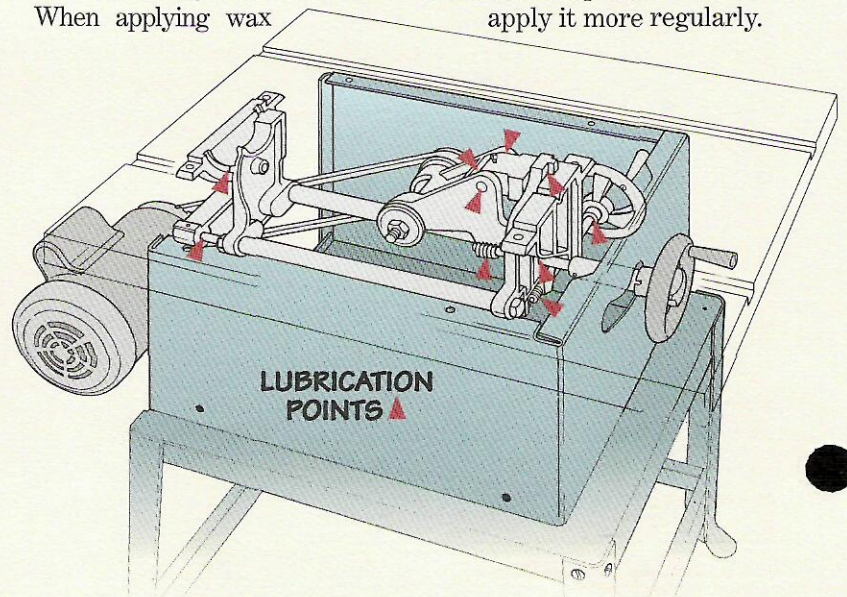



## Table Top

When it comes to an automobile, it doesn't matter how good the engine is if the body around it is completely rusted away. The same holds true for a table saw. If the cast iron table top isn't main-

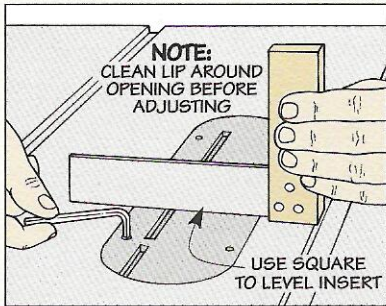

**Insert.** It's much safer operating a table saw with the insert maintained flush with the table top.

tained, the condition of the trunnion underneath it won't matter a whole lot.

There are three basic steps I follow for maintaining a cast iron table top: remove rust and dirt, seal it with a protective topcoat, and check the insert.

I'm always on the lookout for rust so I can take care of it before it becomes a problem, see top photo at right. And after removing any rust, seal the top by spraying on a protective topcoat, see bottom photo at right.

Finally, I check and adjust the saw blade insert to make sure it's flush and level with the table top so a workpiece won't catch or hang-up during a cut, see drawing.

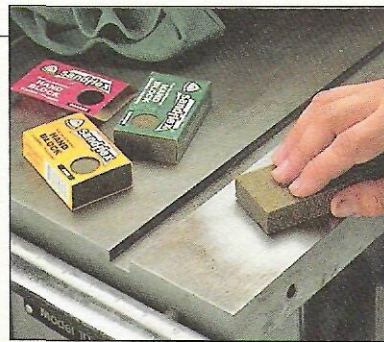

◀ **Remove Rust.** Grit-embedded scouring blocks, like this Sandflex, work great for removing rust and grime from a cast iron table top.



◀ **Protect Top.** After cleaning the top with mineral spirits or denatured alcohol, apply a coat of protection to prevent rust.

## Rip Fence

If a workpiece binds during a cut, there's a good chance the fence isn't adjusted properly. To check the fence, I use the same jig used for checking the trunnion (page 7).

But while the trunnion must be parallel to the miter gauge slot, I adjust my rip fence so it's slightly canted from the slot (about  $\frac{1}{32}$ "). This still allows for straight cuts, while reducing the chance of a workpiece binding between the blade and the fence.

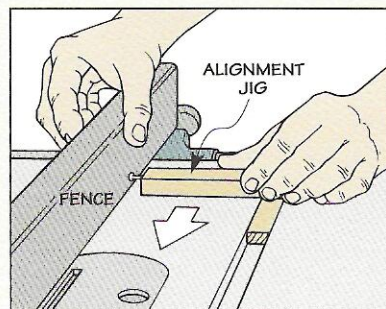

**Step 1.** To align the fence, first lock it down with it just touching the screw on the alignment jig.

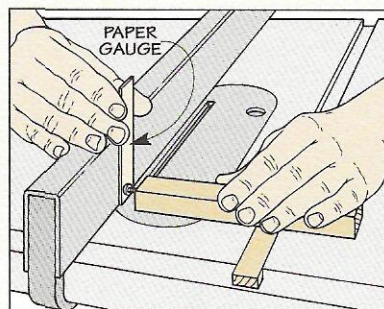

**Step 2.** Now slide the jig to the far end of the fence and adjust the fence for about a  $\frac{1}{32}$ " gap.

## Miter Gauge

With use, the bar on your miter gauge can rattle around in the miter gauge slot. To take up the slack, all you need to do is make a small dimple on one side of the bar with a center punch.

Also, just like the angle indicators on the trunnion, the indicators on the miter gauge will only get you close. Here again, I take the time to use a triangle or square to double-check the setup to make sure the angle is right on. 🛠️

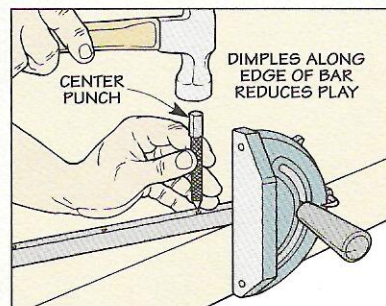

**Loose fit.** Dimples made on the side of a miter gauge bar will take up some of the slack in the slot.

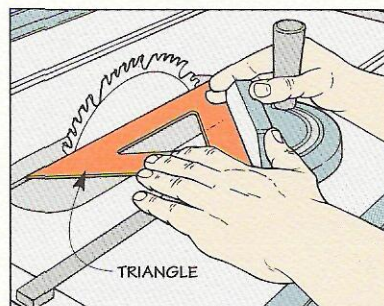

**Check Angle.** Before using your miter gauge, it's a good idea to double-check your setup.



# Utility Ladder

*Here's a sturdy ladder with all the features you've been looking for.*

Everytime I use a rickety step ladder, I promise myself I'm going to build one that's sturdy. The only problem is this requires cutting perfectly-matched angled dadoes. So I started by coming up with a simple way to do this (see the article on page 12), then set out to build a ladder, see photo.

To eliminate any chance of wobble, the ladder legs are 33% wider than legs on a conventional ladder. And there's stiffer bracing throughout. For the material, I used Douglas fir because of its strength to weight ratio.

While I was at it, I added a tray on top to keep tools and materials handy,

(a gallon can of paint fits just right). And so two people can work off the ladder at the same time, it has rungs on both sides.

The utility ladder consists of two identical leg assemblies hinged at the top and held apart by a pair of braces, see Exploded View. I began work by making the leg assemblies.

## LEG ASSEMBLIES

Each leg assembly consists of two legs that are mirror images of each other, three rungs and supports, and a tray, see Exploded

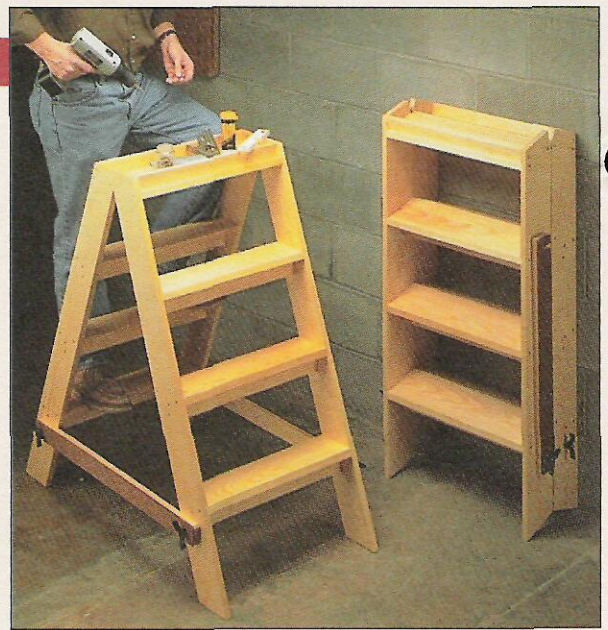

View. The first step is to cut four legs (A) to finished width and rough length, see detail in Exploded View. Then cut a 22° miter on the ends of each leg.

**EAR.** Next, to allow the leg assemblies to butt up against each other once they're hinged together, the top (inside) ear of each leg is cut at a 90° angle, see Fig. 1.

**TEMPLATE.** Now a set of angled dadoes can be cut to accept the rungs. To ensure the dadoes

## Materials

To build this project you'll need five 8'-1"x6"'s, one 4'-1"x6", one 6"x4x8" piece of 1/4" Masonite, and the following hardware:

- (60) #8 x 1 1/2" Fh Woodscrews
- (2) 4" Strap Hinges w/screws
- (4) 1/4" Plastic Wing Nuts
- (2) 1/4"-20 x 24" Threaded Rods

A complete hardware kit is available from ShopNotes Project supplies at 1-800-347-5105.

Kit #525-6825-100.....\$17.95

**EXPLODED VIEW**  
OVERALL DIMENSIONS:  
42" H x 25 1/2" W x 34" D

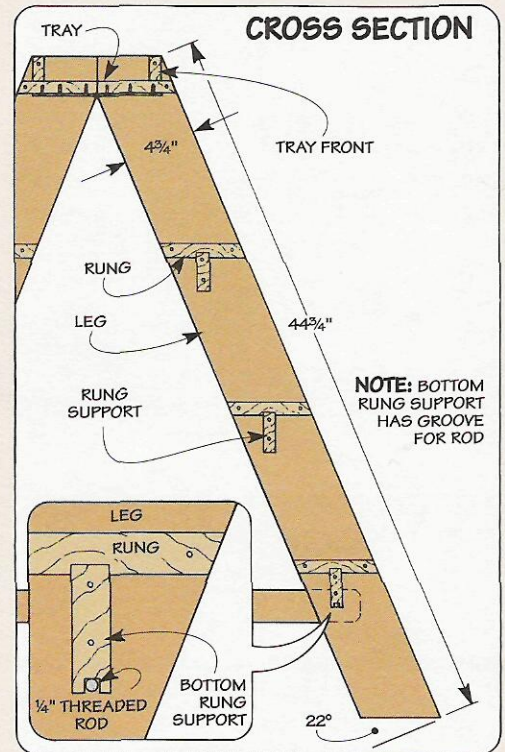
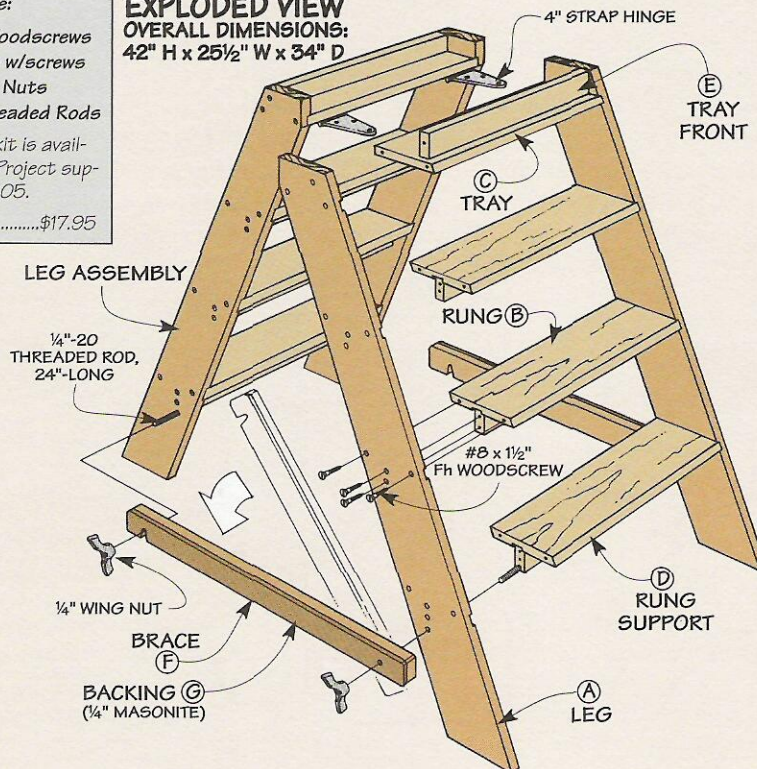

align, I used a template, see Fig. 1. I also used the template to layout the holes for attaching the rungs and supports to the legs.

To use the template, start with it flush at the ends on the *inside* face of the leg. Then scribe or mark a line at the top, mark an "X" to indicate waste, and slide the template up to mark the next dado.

**DADOES.** Once everything is laid out, drill countersunk pilot holes and cut the angled dados (refer to the article on page 12).

**RUNGS & TRAY.** Each leg assembly is held together with three rungs (B) and a tray (C), see Exploded View. To allow the ladder to fold up, the rungs and trays are bevel ripped to match the slope of the legs, see Fig. 2. (Note: Bevel only *outside* edge of each tray.)

Also, a groove is cut down the center of each rung to accept the supports added next, see Fig. 2. There's no groove in the tray — it's not intended for use as a step.

**SUPPORTS.** Once the grooves are cut, you can glue and screw the rungs to the legs. Then to strengthen each rung, cut a support (D) to fit between the legs. Note: The bottom support has a groove cut in it for a threaded rod that's added later, see Fig. 2.

**TRAY.** Once the supports are in place, you can form the tray by adding two tray fronts (E), see Fig. 3. Now the assemblies can be

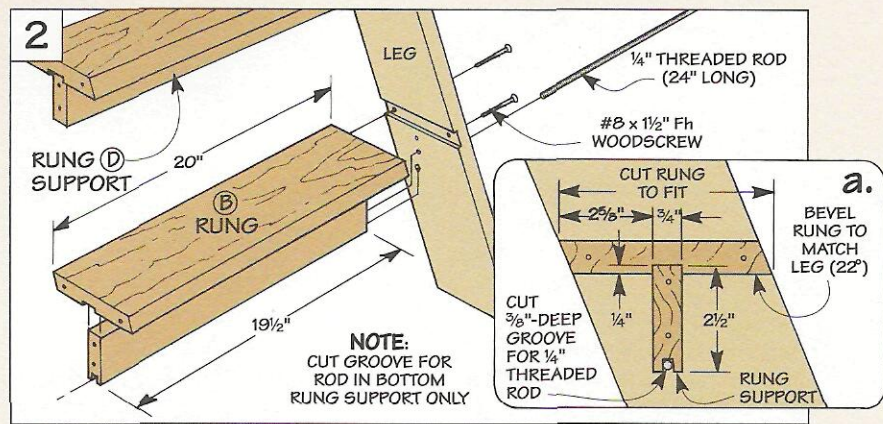
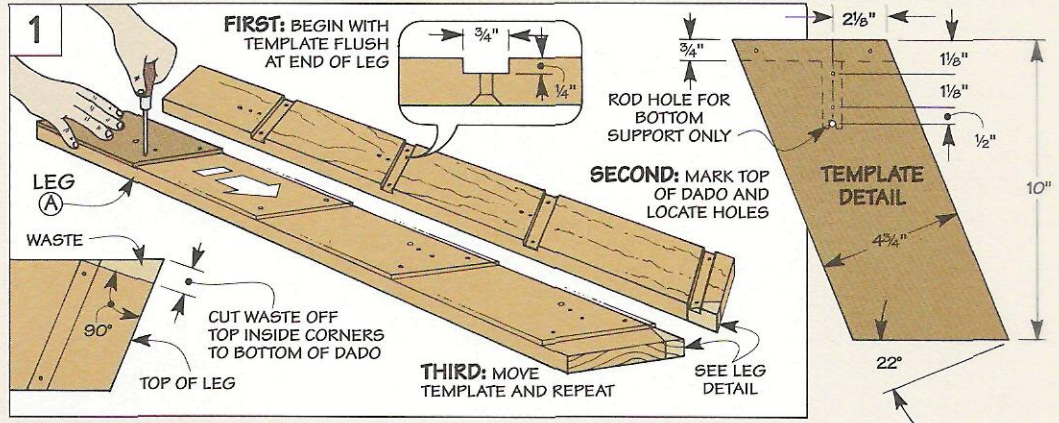

joined together with a pair of strap hinges, see Fig. 3.

**BRACING**

To prevent the legs from splaying apart in use, a brace (F) is added to each side, see Fig. 4. The braces pivot on 24"-long threaded rods that fit in the grooves cut earlier in the bottom rung supports. To strengthen each brace,

I laminated it with a backing (G) made from 1/4"-thick Masonite.

**NOTCH.** Finally, a notch is cut on the end of each brace to allow it to slip over the threaded rod. To locate the notch, unfold the legs and measure between the rods. Then transfer this distance to the brace, drill a hole, and remove the waste. Now slide the braces over the rods and add the wing nuts.

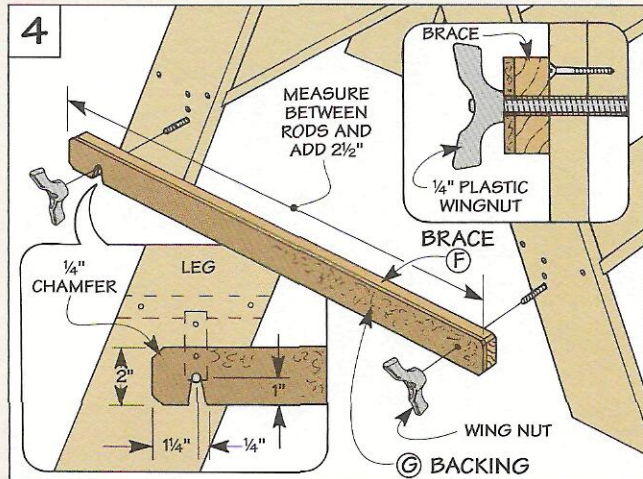
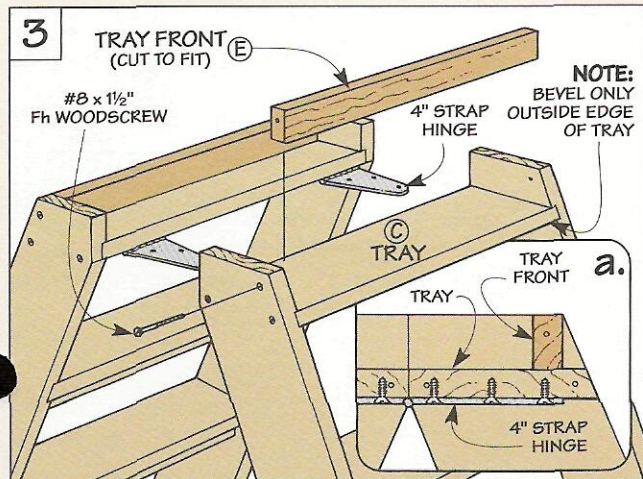

# Cutting Angled Dadoes

*A simple technique...and a shop-made jig. That's all it takes to cut perfectly aligned angled dadoes.*

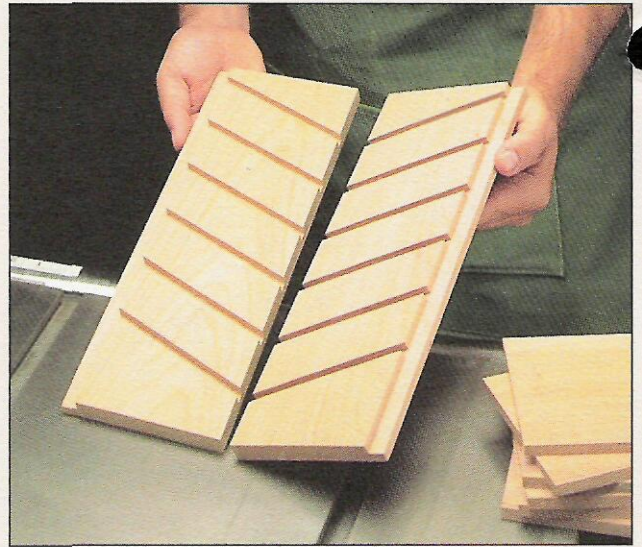

**T**here's nothing all that complicated about cutting *one* set of angled dadoes. The trick is to cut a *second* set that's a mirror image of the first.

That's because after you cut dadoes in one piece, you need to adjust the angle of the miter gauge to cut matching dadoes in the other. And if both angles aren't *exactly* the same, the dadoes won't align.

So when building a project like the utility ladder on page 10 or a CD rack for example, I use a simple technique that aligns the dadoes like stripes on a sergeant's sleeve. All it takes is two things: an accurate layout, and a shop-made angle gauge to set your miter gauge. (For more on making

and using an angle gauge, see the box on page 13.)

## LAYOUT

When laying out the dadoes, there are several things you can do to build in accuracy.

**GANG PIECES.** First, it helps to "gang" the pieces together and lay out the dadoes on both pieces at once, see Step 1 below. Just be sure to clamp the pieces together so the ends are flush and the sides that will be dadoed are facing each other.

**SINGLE LINE.** Another way to ensure accuracy is to use a *single* line to lay out each dado. This way, you'll be able to adjust the dado blade to whatever width

you want without affecting the accuracy of the layout. To avoid cutting to the wrong side of the line, don't forget to mark the waste area with an 'x.'

**SIDES.** Once the edges are marked, you can lay out the sides. This is where the angle gauge comes in handy. After using it to set the angle on a bevel gauge, just transfer the angle to one side of each workpiece, see Step 2.

## CUT DADOES

With the layout complete, you're ready to cut the dadoes. As with any dado (angled or straight) there are a couple of preliminaries to take care of first.

**WIDTH OF CUT.** For starters, adjusting the width of cut. What you're after is to adjust the width of the blade to match the thickness of the piece that will fit in the dado. And the only way I've found to get a snug (not tight) fit is to make a test cut, check the fit, and readjust the blade if necessary.

**FENCE.** Also, to prevent chipout on the edge of the workpiece, I attach a scrap wood fence to the miter gauge. Note: Make sure the fence is long enough to extend past the blade when you tilt the head of the miter gauge, see Step 3.

**ADJUST ANGLE.** With the fence in place, you can adjust the angle

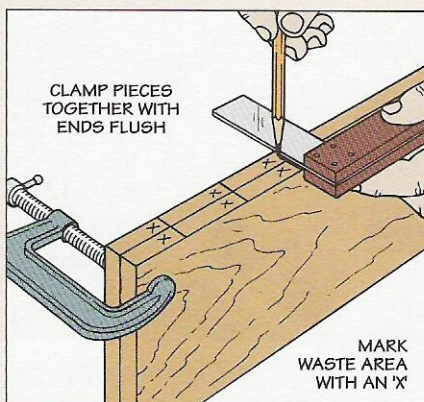

**Step 1.** With the pieces clamped together, lay out a single line for each dado across one edge of each piece.

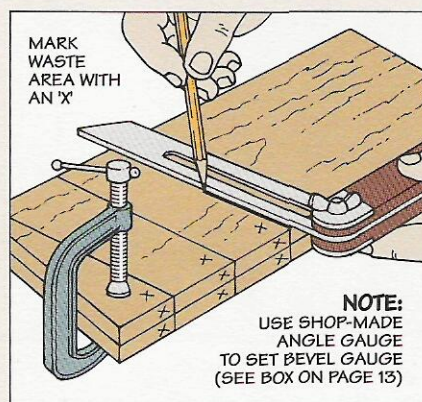

**Step 2.** Using a bevel gauge, lay out an angled line for each dado on both sides of the clamped-up assembly.

of the miter gauge to cut the first set of dados. Here, the angle gauge makes quick work of finding the exact setting, see the box below.

But even with the correct angle, you still need a way of aligning the workpiece to the blade so the dados end up exactly where you want them.

**NOTCH.** An easy way to do this is to cut a notch in the fence and use it as a reference, see the drawings in right-hand margin. The thing to be aware of is if the notch is too tall, the edge of the workpiece will chip out when the blade cuts through.

To get around this, I cut the notch so its *height* equals the desired *depth* of the dado. The best way to do this is to make a pass with the blade set low, then sneak up on the final depth of cut.

**MATCHING DADOES.** After you cut one set of dados, all that's left is to cut the matching dados in the other piece, see Step 4. Here again, use the angle gauge to set the miter gauge. Note: Before cutting these dados, you'll need to cut another notch in the fence. 

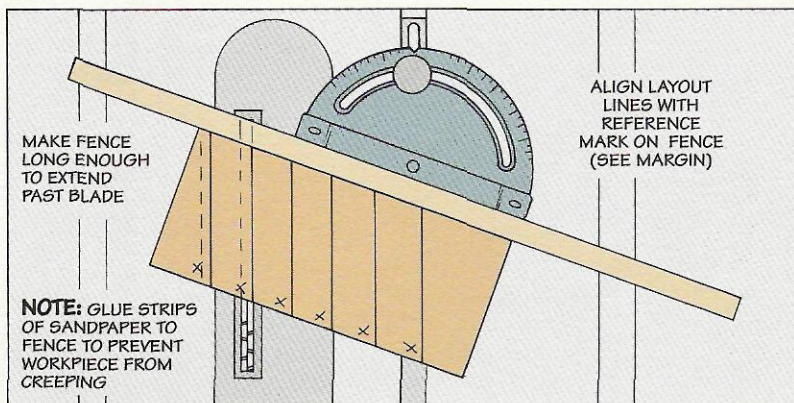

**Step 3.** Before cutting the first set of dados, use the angle gauge to set the miter gauge at the desired angle. Then align each layout line with the reference mark on the fence to cut the dados.

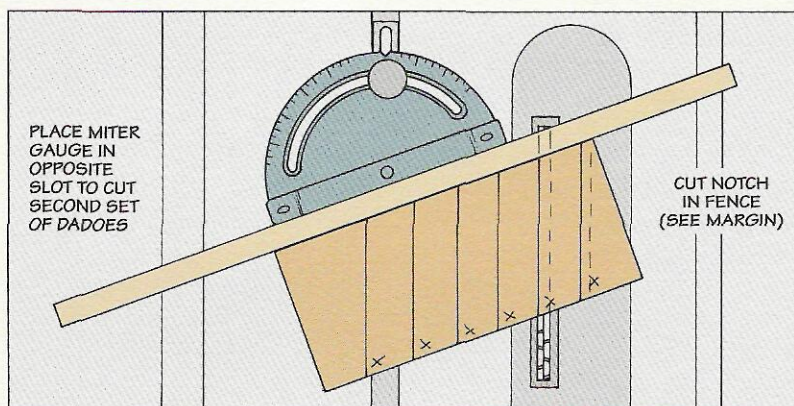

**Step 4.** To cut the second set of dados, you'll need to do two things. Adjust the miter gauge to the opposite angle (using the angle gauge) and place the miter gauge in the opposite slot.

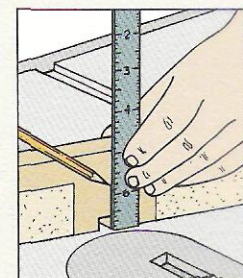

To indicate the path of the dado blade, extend a line from the side of a notch cut in the fence.

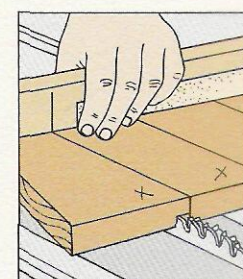

Aligning the mark on the fence with a layout line allows you to cut the dado quickly and accurately.

## Angle Gauge

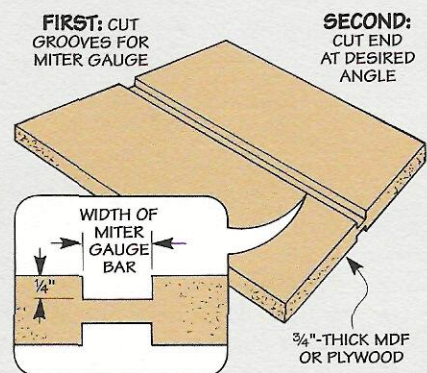

▲ An angle gauge is easy to make. It's a scrap with a groove in each side to accept your miter gauge. And one end is cut to the desired angle.

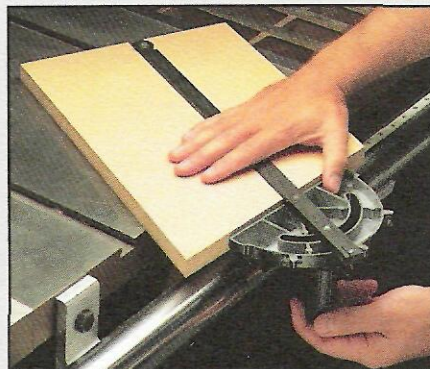

**First Angle Setting.** To set the first angle, hold the miter gauge upside down, pivot the head so it's tight against the end, and lock it in place.

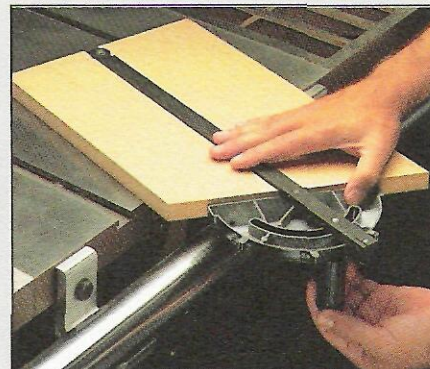

**Second Angle Setting.** Flipping the angle gauge over and repeating the process automatically sets the miter gauge to the exact opposite angle.

# Hardware Tips

*Here's a collection of great hardware tips to help you successfully complete your next project.*

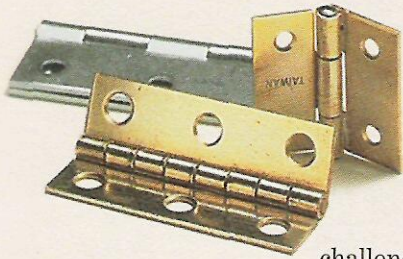

## Hinges

■ It can be a real challenge cutting a mortise to fit a hinge. The quickest and easiest way I've found to do this is to use a handheld router and a couple of simple tricks.

The first trick ensures that the depth of the mortise will be perfect. Just set your router on two open hinges and adjust a straight bit to barely touch the workpiece, see Fig. 1.

The second trick allows you to support the router during a cut and guarantees the bottom of the mortise ends up flat. All you have to do is sandwich the workpiece between two scraps, see Fig. 2.

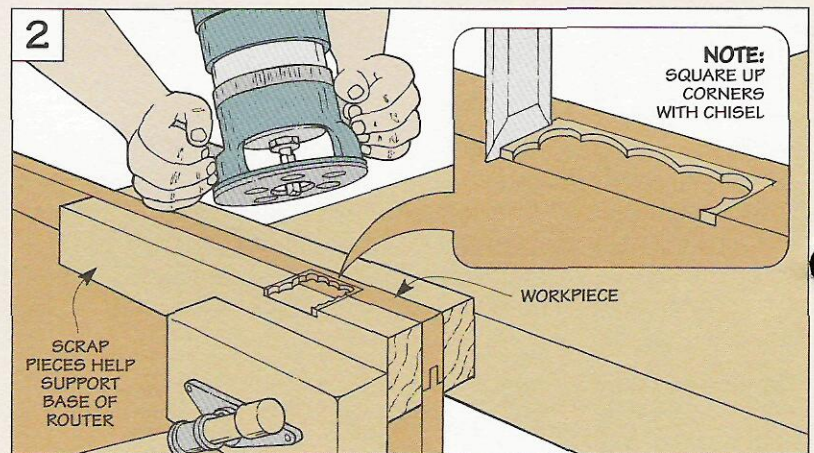
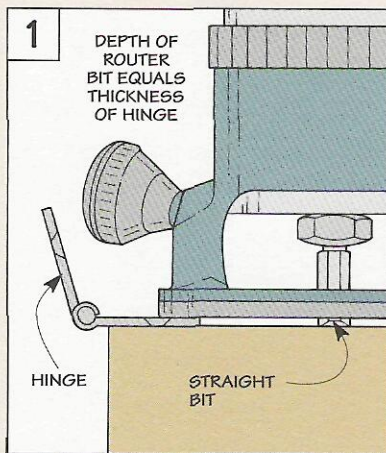

## Magnetic Catches

■ Most magnetic door catches consist of two parts: a magnet and a catch plate (or screw). To install one properly, two things must be done. First, the magnet has to be

seated straight in the hole and flush with the work surface. To do this, I guide the magnet in the hole with a block of wood, see Fig. 1.

Second, in order for a door to stay closed, the catch must align

with the magnet. To ensure it does, I place the screw on the magnet, close the door, and tap the door with a no-mar hammer, see Fig. 2. The mark left behind indicates where to mount the catch.

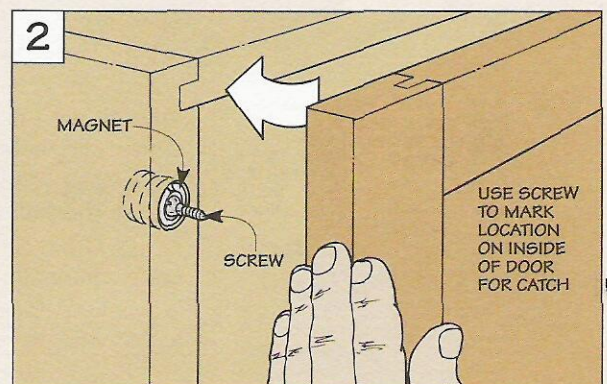
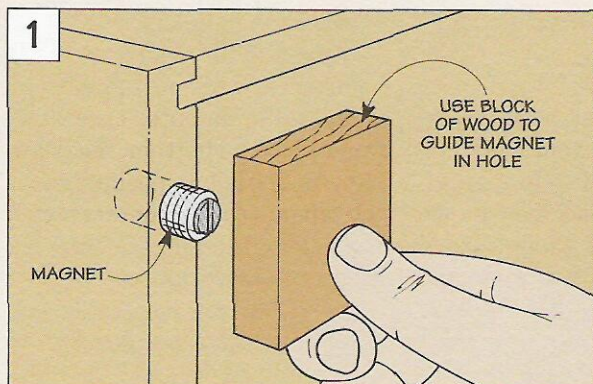

## Keyhole Hangers

■ Drilling and cutting a mortise in a picture frame for a keyhole hanger can be a time consuming process. So can locating where to mount the screw in the wall for the frame to hang on.

If I'm not concerned about mounting the frame so it's flat against the wall, I take a shortcut by drilling a hole just large enough to fit the slot in the hanger, see Fig. 1. Then I mount

the hanger over the hole.

To locate the screw in the wall, a wire brad (with the head removed) is nailed in the frame and used to mark the wall, see Fig. 2.

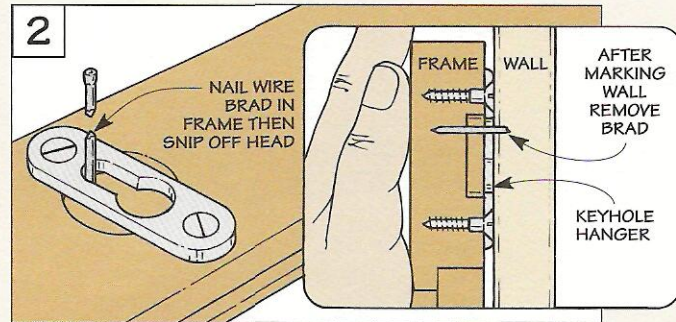
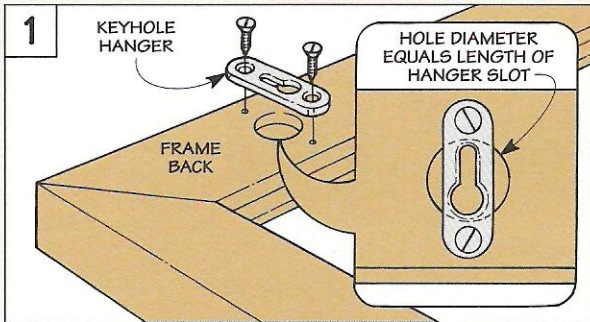

## Knobs & Pulls

■ When mounting hardware, the last thing I want to happen is to drill a hole, mount the hardware, and then decide I don't like how it looks. To avoid this, I often carpet tape the hardware in place

and take a step back to see how it looks, see Fig. 1. This way, I can try different pieces of hardware and different positions.

Once I've found what looks best, I'll often take a few extra

minutes to make a drilling guide from a piece of Masonite and a scrapwood cleat, see Fig. 2. The guide eliminates tedious layout and helps locate the holes in the same place.

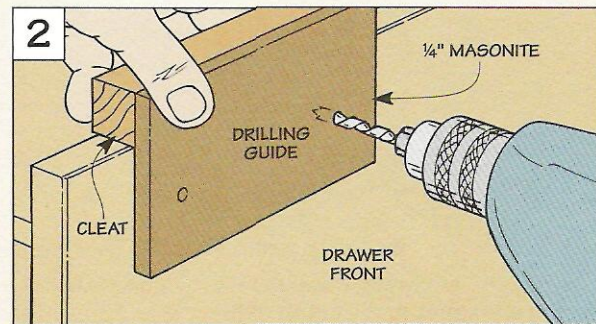
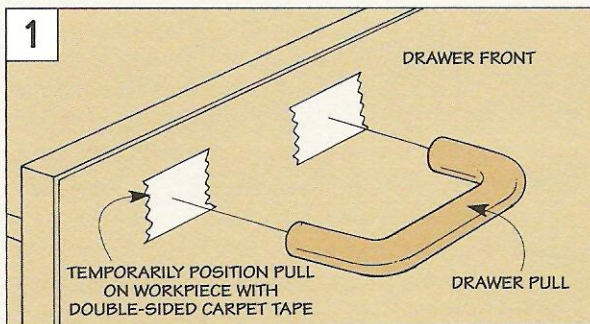

## Self-Centering Drill Bits

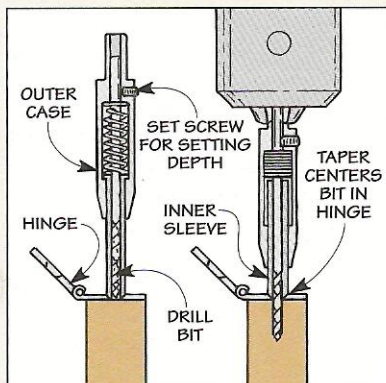

■ Before discovering self-centering drill bits, drilling perfectly-located pilot holes for hinge screws was hit or miss at best. Sometimes the holes would end up where they should — in the center of the hole machined in the hinge. Other times the bit would catch the grain of the wood and get pulled off center — resulting in a misaligned hinge.

But not anymore. With self-

centering bits, pilot holes end up exactly where they should. The reason? The drill bit is housed in an outer case that's tapered at the bottom, see drawing. As the bit is pushed down, the taper of the bit centers it over the hole in the hinge just before it enters the workpiece.

These bits are commonly sold as Vix bits, spring-action bits, or self-centering drill bits.

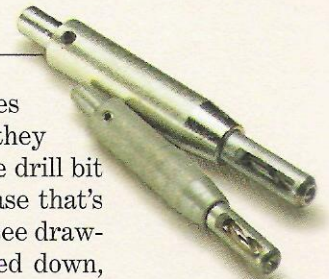

# Table Saw Cabinet

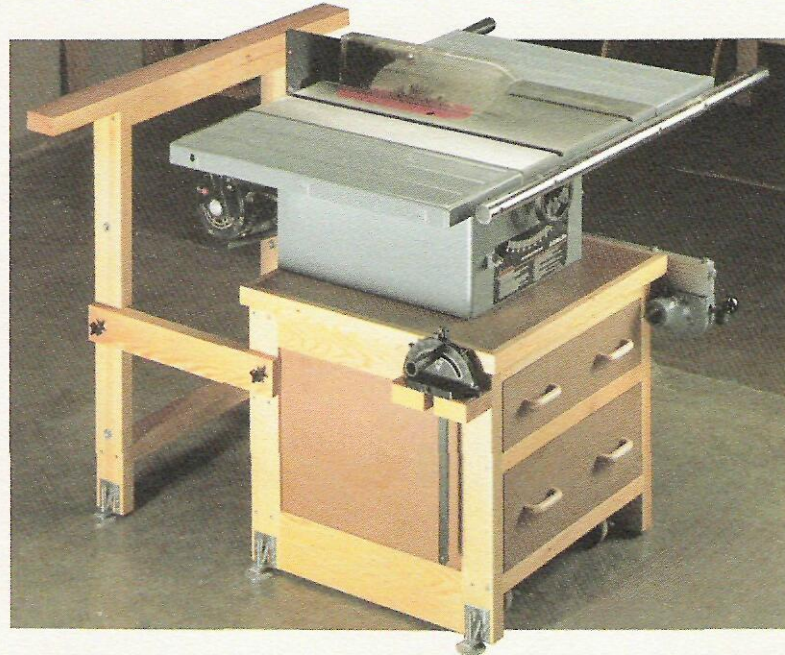

**T**he stand on my table saw has always struck me as a bit of an afterthought—a “bare bones” metal frame that supports the saw. But by replacing it with this shop-built cabinet, I was able to make a number of improvements.

**STORAGE.** First, there’s a large drawer for storing jigs, accessories, and extra saw blades, see photo A. And the miter gauge and rip fence are held in place with simple brackets when they’re not in use.

**DUST COLLECTION.** Besides adding storage, the cabinet also provides a way to control dust. A pull-out bin collects the dust, see photo B. Or, as an option, you can hook a dust collector up to the bin,

*It’s easy to “build-in” improvements to your table saw with this sturdy cabinet.*

refer to page 20.

**OUTFEED.** As much as I appreciate how this cabinet gives me a handle on dust, there’s one thing I like even better—an outfeed support. It attaches to the cabinet and makes it easy to cut large workpieces, see photo C.

**STABILITY.** Finally, this cabinet is much more stable than my old metal stand. The reason is simple—it’s heavier. Made from medium-density fiberboard (MDF) and Douglas fir, there’s enough mass to dampen any vibration caused by the saw.

But regardless of its weight, casters make the stand easy to roll around. And once it’s in place, special levelers raise it off the casters for rock solid support.

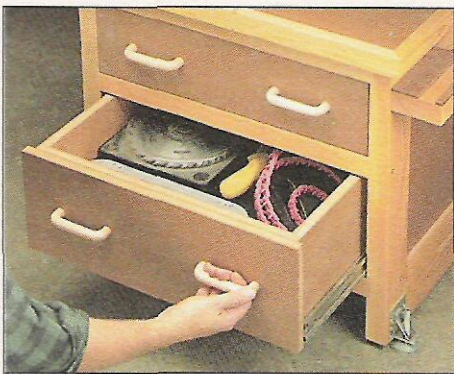

**A. Storage.** Saw blades and accessories are stored in a large drawer. And brackets hold the rip fence and miter gauge.

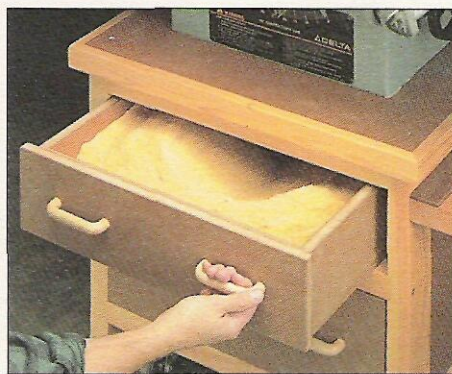

**B. Dust Bin.** A bin below the saw cabinet collects dust. When it’s full, the bin pulls out for easy emptying.

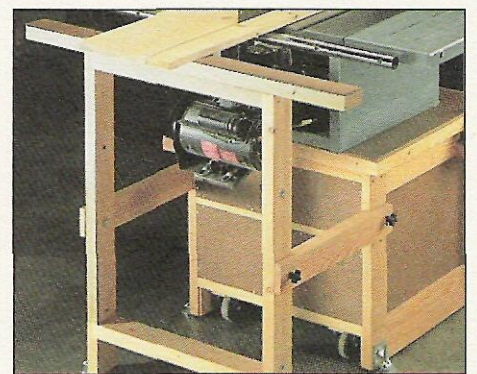

**C. Outfeed.** To make cutting large workpieces more manageable, an outfeed support attaches to the stand.



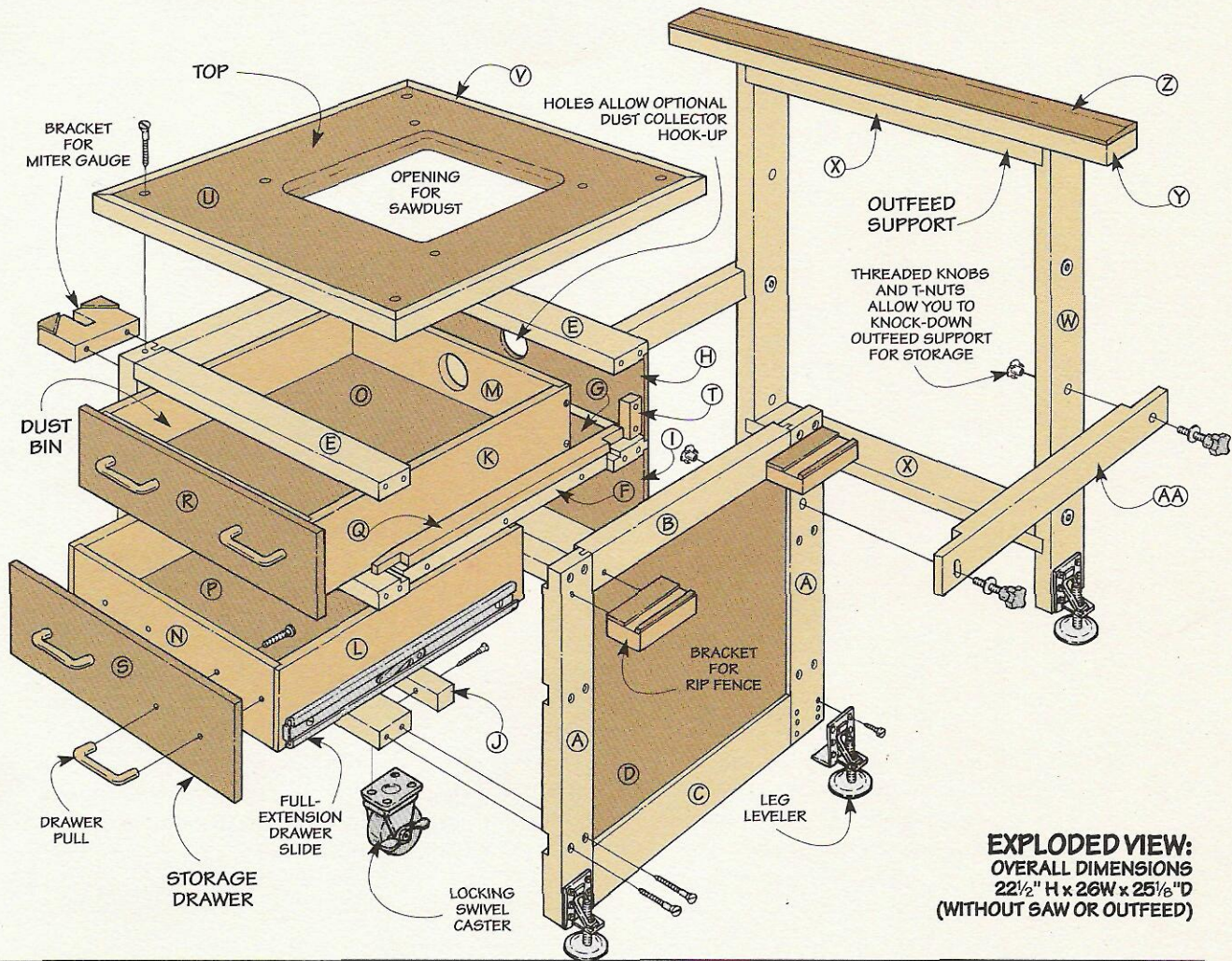

**EXPLODED VIEW:**  
OVERALL DIMENSIONS  
22½" H x 26" W x 25½" D  
(WITHOUT SAW OR OUTFEED)

## Materials

### Base

A Stiles (4)	1½ x 3 - 21
B Upper Side Rails (2)	1½ x 3 - 19
C Lower Side Rails (2)	1½ x 4¾ - 19
D Sides (2)	14¼ x 19 - ¾ MDF
E Front/Back Rails (6)	1½ x 3 - 21½
F Cleats (2)	1½ x 1½ - 18
G Dust Shelf (1)	19 x 19¾ - ¼ Masonite
H Upper Back Panel (1)	6¼ x 21¾ - ¼ Masonite
I Lower Back Panel (1)	8½ x 21¾ - ¼ Masonite
J Support Strips (2)	1½ x 2 - 21

### Dust Bin & Storage Drawer

K Bin Sides (2)	5 x 22 - ¾ MDF
L Drawer Sides (2)	7¼ x 22 - ¾ MDF
M Bin Front/Back (2)	5 x 19¼ - ¾ MDF
N Drawer Front/Back (2)	7¼ x 19¼ - ¾ MDF
O Bin Bottom (1)	19¼ x 21¼ - ¼ Masonite
P Drawer Bottom (1)	19¼ x 21¼ - ¼ Masonite
Q Guides (2)	7/8 x 21½ - ¾ MDF
R False Bin Front (1)	5¾ x 20¾ - ¾ MDF
S False Drawer Front (1)	7¾ x 20¾ - ¾ MDF
T Stops (2)	1 x 3 - ¾ MDF

### Top

U Top Pieces (2)	23⅝ x 24½ - ¾ MDF
V Trim Strips (2)	1½ x ¾ - 60

### Outfeed Support

W Uprights (2)	1½ x 3 - 33¾
X Rails (2)	1½ x 3 - 22½
Y Top (1)	1½ x 3 - 40
Z Cover (1)	3 x 40 - ¼ Masonite
AA Arms (2)	1½ x 3 - 20

## Hardware

- (28) #8 x 3" Fh Woodscrews
- (16) #14 x 5/8" Panhead Screws
- (16) 1/4" Flat Washers
- (2) 3" Locking Swivel Casters
- (2) 3" Fixed Casters
- (4) #8 x 1½" Fh Woodscrews
- (24) #6 x 3/4" Fh Woodscrews
- (4) 3¾" Drawer Pulls
- (8) 8-32 x 1¾" Machine Screws
- (6) Heavy-Duty Leg Levelers
- (36) #8 x 3/4" Rh Woodscrews
- (6) #8 x 2" Fh Screws\*
- (12) 5/16" T-Nuts
- (4) 5/16" x 1½" Hex Bolts
- (8) 5/16" Flat Washers
- (4) 5/16" x 2¼" Threaded Knobs
- (6) #10 x 4" Fh Woodscrews
- (8) #8 x 1¼" Screws\*
- (20) #8 x 1½" Screws\*
- (1 pr.) 22" Full-Ext. Drawer Slides

\*To avoid splitting MDF, use flathead sheet metal screws with a straight shank.

Note: If you're hooking up the table saw stand to a dust collector or shop vacuum, you'll also need a plastic coupler.

For a complete hardware kit, call ShopNotes Project Supplies at 800-347-5105.

Kit No. 525-6825-200 .....\$149.95

# Base

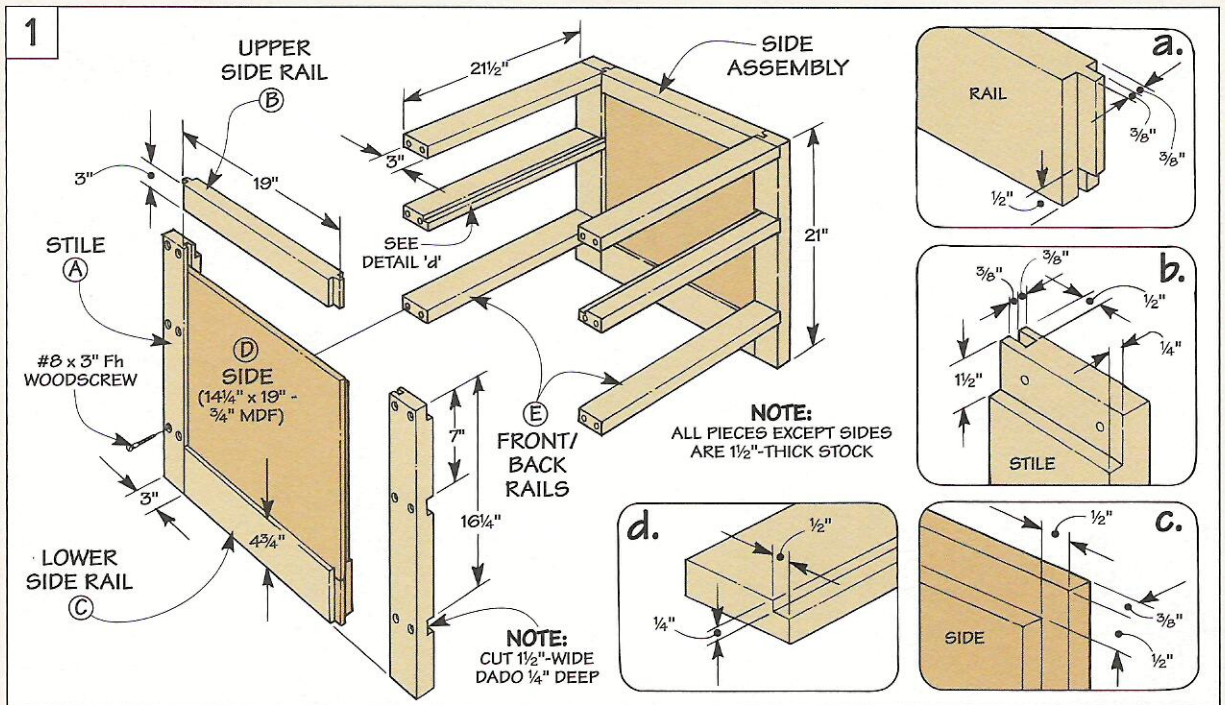

An Allen wrench is all that's needed to adjust these heavy-duty levelers and raise the cabinet off its casters.

Besides supporting the top of the cabinet, the base houses the dust bin and storage drawer.

**SIDE ASSEMBLIES.** The base starts out as two side assemblies. These are “two-by” wood frames and  $\frac{3}{4}$ ”-thick MDF panels that are held together with stub tenon and groove joints, see Fig. 1.

Each frame consists of two *stiles* (A), and an *upper* (B) and *lower side rail* (C). To accept the stub tenons on the rails and a tongue on the panel (cut later), there’s a

groove cut in each piece, see Fig. 1b. What’s unusual here is these grooves are cut *off-center*.

That’s because the panels that form the *sides* (D) of the cabinet are rabbeted on all four edges to form a tongue, see Fig. 1c. Fitting this tongue into the groove centers the side in the frame.

Before gluing up the side assemblies, you’ll need to cut stub tenons on the ends of the side rails, see Fig. 1a. And two dados and a rabbet cut in each stile will

accept a set of rails that holds the side assemblies together.

**RAILS.** Besides adding rigidity, the *front/back rails* (E) form the openings for the dust bin and storage drawer. Although they’re identical in size, the top inside edge of each middle rail is rabbeted for a dust shelf, see Fig. 1d. Then the rails are screwed in place.

**DUST SHELF.** The dust shelf keeps dust from filtering into the storage drawer. In addition to the middle rails, it’s supported on the sides by two *cleats* (F) that are also rabbeted on the top inside edge, see Figs. 2 and 2a. After gluing and screwing the cleats in place, cut a Masonite *dust shelf* (G) to fit. And glue it into the rabbets.

**BACK.** The back of the cabinet is also enclosed with pieces of Masonite. After routing a rabbet around the openings in back, just cut an *upper* (H) and *lower back panel* (I) to fit and glue and screw them in place, see Figs. 3 and 3a.

**CASTERS.** To make the cabinet easy to roll around, I added a set of heavy-duty casters. But first, to provide a large mounting sur-

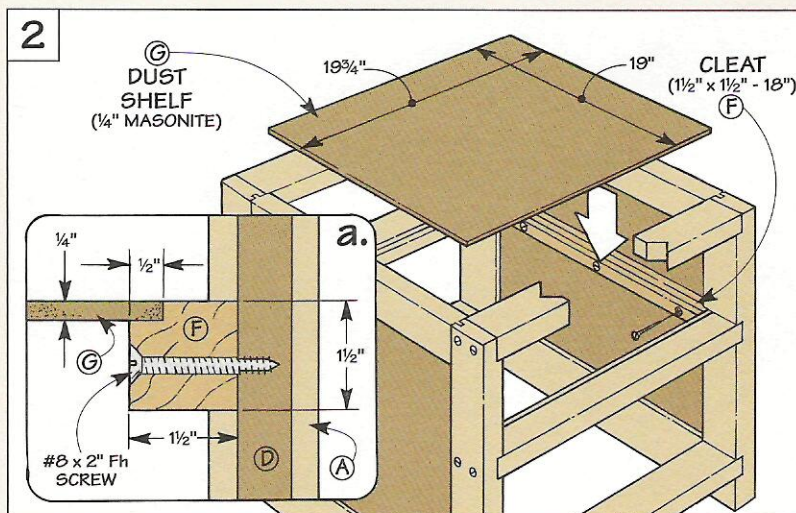

face, *support strips (J)* are glued and screwed to the bottom rails. Then install a pair of locking swivel casters in front and fixed casters in back, see Fig. 3b.

**LEVELERS.** Even with locking casters, I was still concerned the cabinet might “creep” when the saw is running. So I installed levelers to raise the cabinet off the casters when the saw is in use, see margin on page 18.

**DUST BIN & DRAWER**

Now you can build the dust bin and drawer to fit their openings.

The length of the bin and drawer is the same (22"), see Fig. 4. And so is the width (20"). This allows for guides for the bin and drawer slides. But their height is different. To allow for false fronts (added later), they're 1/2" shorter than their openings (5" and 7 1/4").

To build the bin and drawer, start by cutting the *sides (K and L)* to size, see Fig. 4. Then rabbet the ends of each piece to accept *front/back pieces (M and N)*. After cutting a groove in each piece for *bottom pieces (O and P)*, assemble them with glue and screws.

**SLIDES.** To provide easy access to the drawer, full-extension slides are installed on the storage drawer. But I took a different approach with the bin.

**GUIDES.** To eliminate the hassle of “releasing” a slide to pull out the dust bin, I made two *guides (Q)*, see Figs. 5 and 5a. These are strips of MDF that are notched to fit around the stiles. To help guide the bin into the opening, the front ends are tapered.

**FALSE FRONTS.** With the guides glued in place, I installed the bin and drawer and added the *false fronts (R and S)*. They're cut to allow 1/16" gap all the way around and attached with screws, see Fig. 4b.

Finally, after installing pulls, I screwed in *stops (T)* to keep the bin and drawer flush with the front of the cabinet, see Fig. 5a.

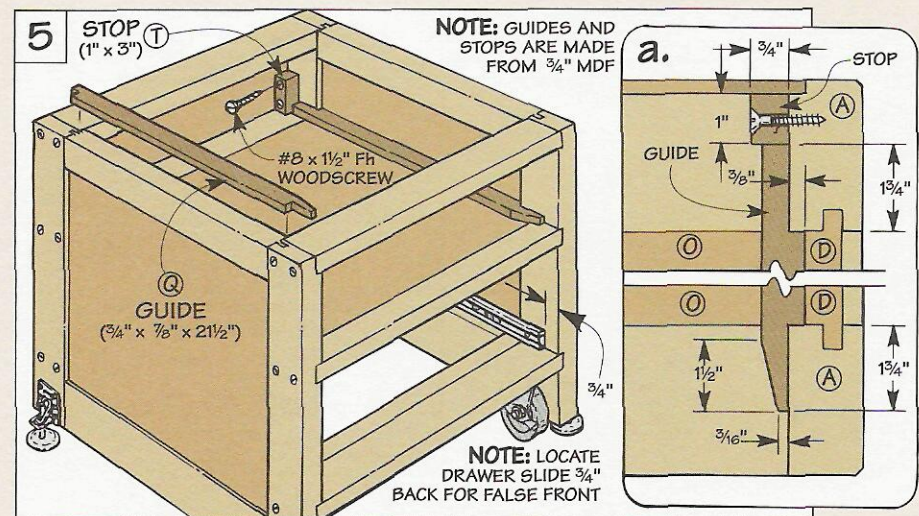
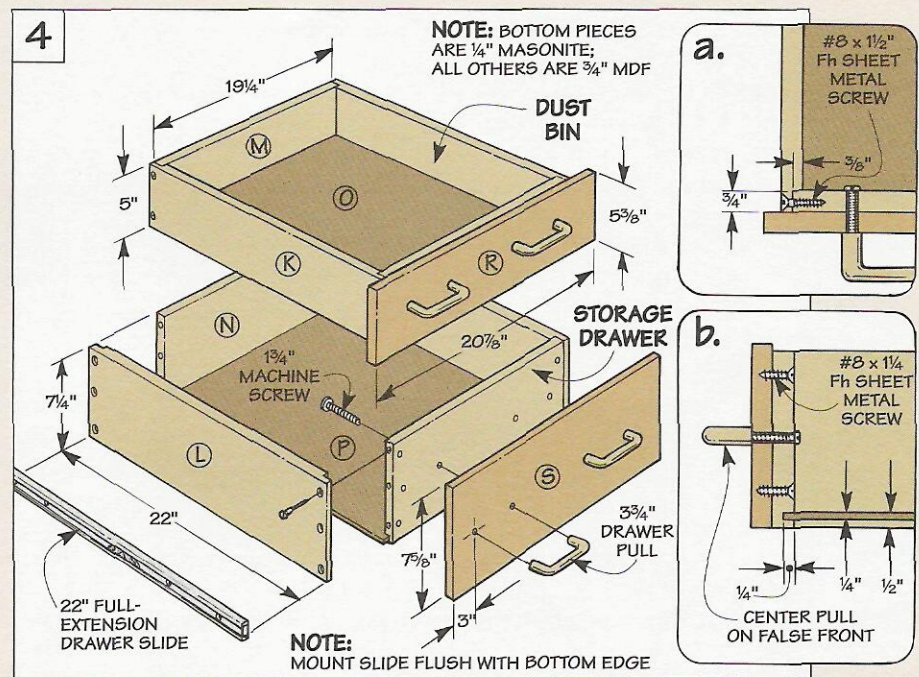
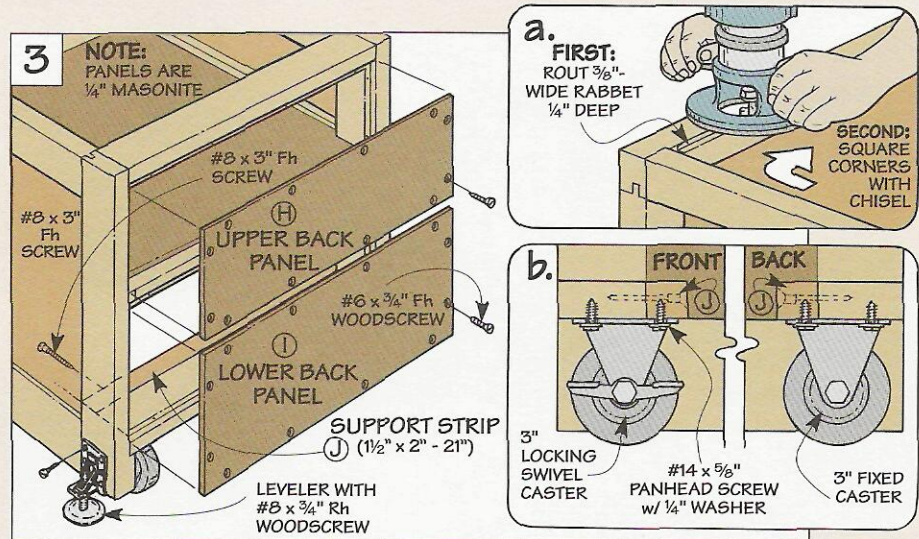

Top

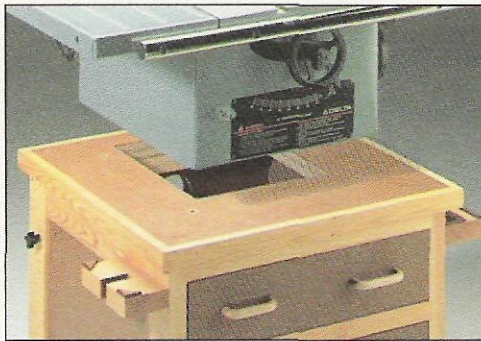

▲ A built-up top with a hole cut in it allows sawdust to fall through. It also provides a sturdy platform to mount the table saw.

The top acts as a mounting platform for the table saw. So I wanted a thick, heavy slab to help dampen any vibration. (Note: If you plan to hook up a dust collector, it's easiest to do it *before* making the top, see box below.)

The top is built up from two pieces of  $\frac{3}{4}$ "-thick MDF, see Fig. 6. What I found worked best here is to cut one *top piece* (U) to size first. Then glue on a second (slightly oversize) piece with contact cement and rout the edges with a flush trim bit.

**TRIM.** To cover the exposed edges, the top is "wrapped" with *trim strips* (V). These are just pieces of  $1\frac{1}{2}$ "-thick stock that are

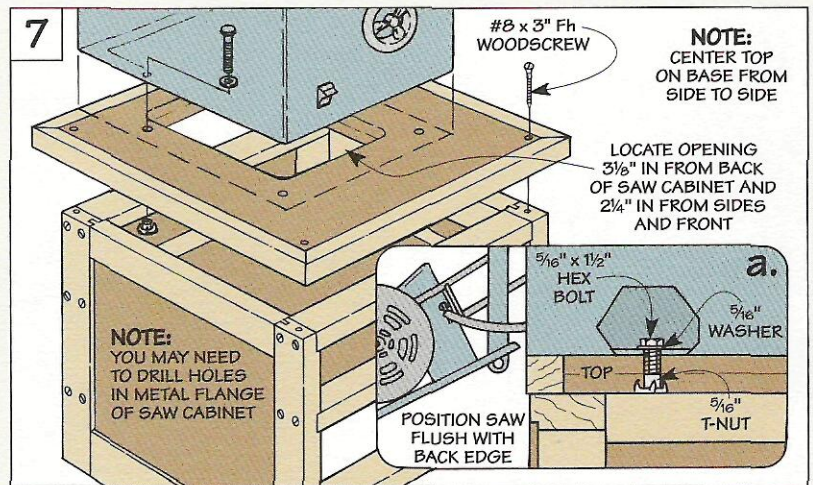
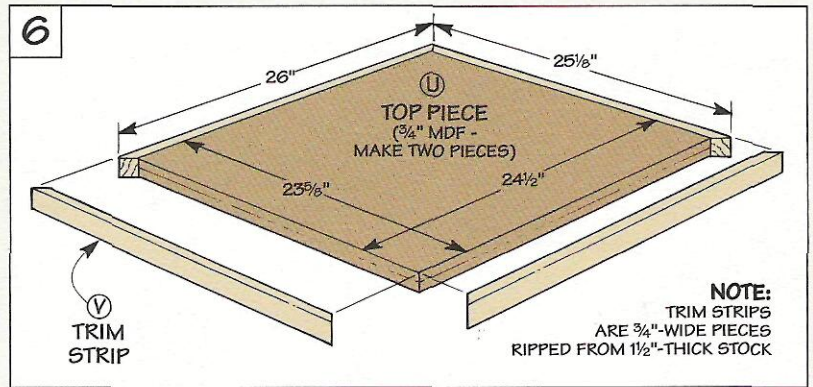

ripped to a width of  $\frac{3}{4}$ ". After mitering the strips to length, they're simply glued in place.

**OPENING.** At this point, you can screw the top to the base and lay

out an opening for dust to fall through, see Fig. 7. The location of this opening is determined by the position of the metal saw cabinet.

If it's a contractor-type saw where the motor hangs off the back, there's one thing to be aware of. Since the motor swings to the side when you tilt the blade, you'll have to allow for clearance to keep it from hitting the top.

To do this, position the metal saw cabinet flush with the back edge and mark around it with a pencil, see Figs. 7 and 7a. Then draw layout lines to the *inside* as shown and cut the opening with a sabre saw.

**ATTACH SAW.** Now you can attach the saw. It's held in place with bolts that thread into T-nuts installed in the top from underneath, see Fig. 7a. Note: For clearance, you may need to drill additional holes in the metal flange of the saw.

Dust Collector Hook-Up

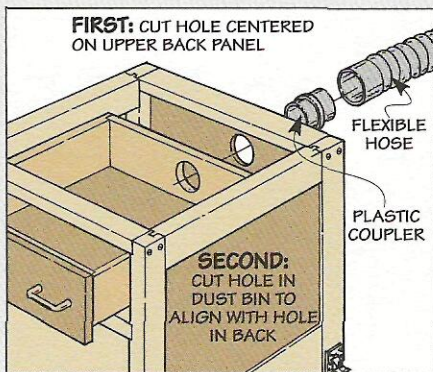

**Coupler.** One end of a plastic coupler fits snug in holes cut in the back of the cabinet and the dust bin.

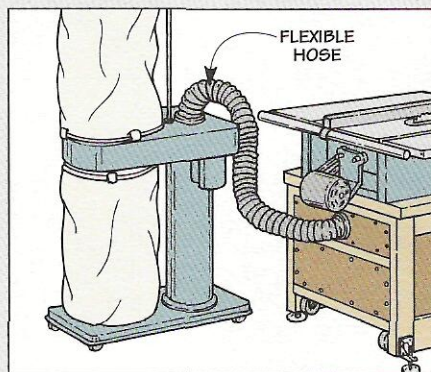

**Dust Collector.** A flexible hose attached to the other end of the coupler hooks up to your dust collector.

# Outfeed Support

With the saw in place, I added an outfeed support to “catch” long workpieces when completing a cut. It consists of three parts: a wood frame, a long crossbar, and a pair of arms to attach it to the cabinet.

To ensure that the workpiece slides smoothly off the saw table onto the outfeed support, the top of the crossbar needs to be at the same height as the saw table.

**FRAME.** So when building the frame, the first step is to determine the height of the *uprights* (W), see Fig. 8. To do this, measure the distance from the bottom of the cabinet to the top of the saw table and subtract the overall thickness of the crossbar (1 3/4”).

The uprights are held together with two *rails* (X). One fits in rabbets cut in the top ends of the uprights. And the other into dados cut near the bottom.

**CROSSBAR.** Once the frame is screwed together, the crossbar is made by gluing up a *top* (Y) made of “two-by” material and a Masonite *cover* (Z). By cutting a wide bevel in the cover (Fig. 8a), even thin workpieces that tend to sag will slip easily onto the crossbar.

**ASSEMBLY.** After screwing the crossbar to the top rail, the out-

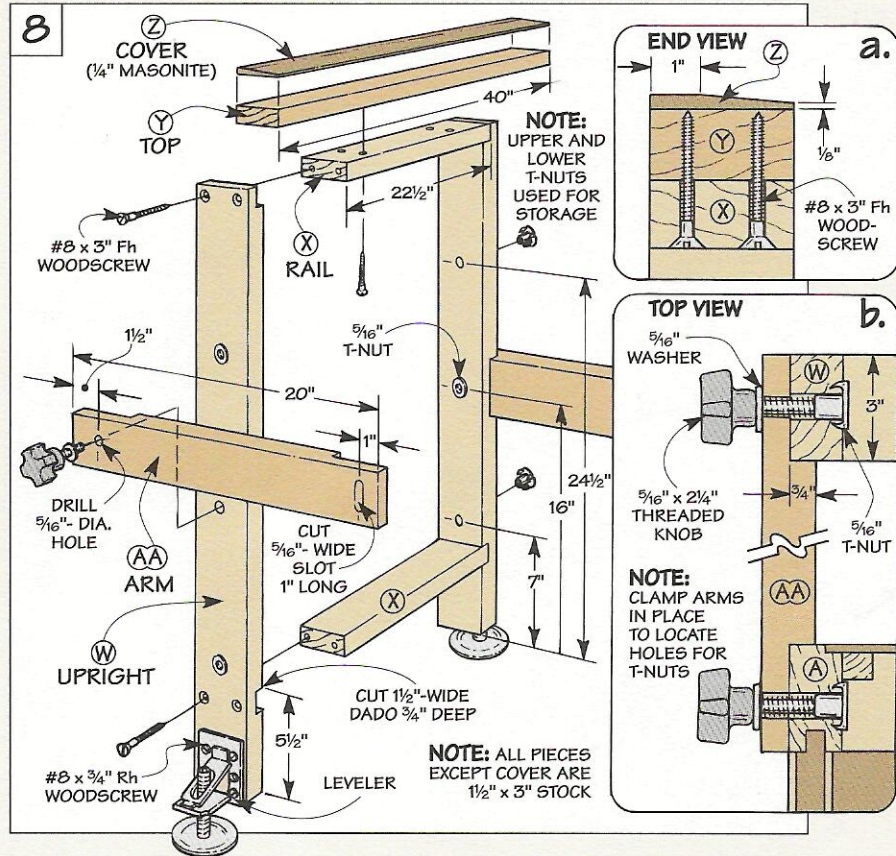

feed support is attached to the cabinet with two *arms* (AA) that are rabbeted on each end, see Fig. 8b. Threaded knobs pass through a hole in one end and a slot in the other (for height adjustment). Tightening the knobs

into T-nuts installed in the uprights and back stiles locks the outfeed support in place.

Finally, after installing levelers on the uprights, I added two T-nuts to each upright for compact storage, see photo below. 

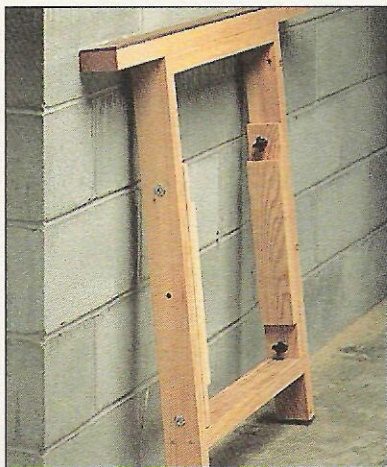

**▲ Storage.** For compact storage, tuck the arms that connect the outfeed support to the cabinet inside the frame and tighten the knobs.

## Accessories

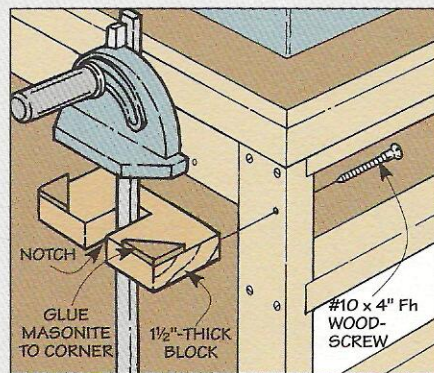

**Miter Gauge.** A block with a notch cut in it holds the miter gauge. And scraps of Masonite keep it from slipping off.

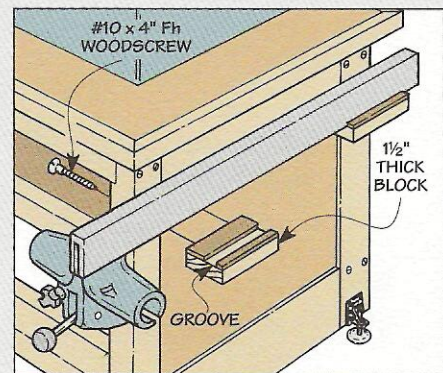

**Rip Fence.** To hold the rip fence, these brackets have grooves formed by gluing strips of Masonite to a wood block.

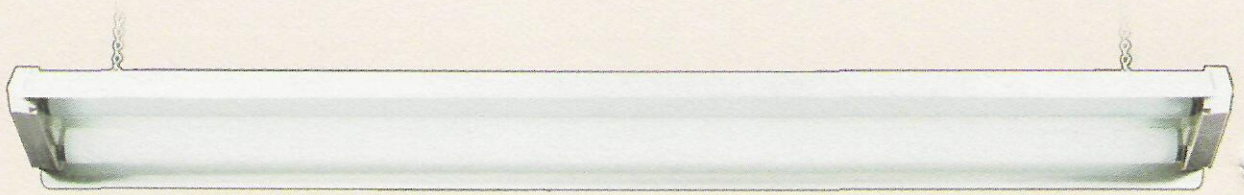

# Lighting in the Shop

**T**here's nothing more frustrating than working in a dimly lit shop. Layout lines disappear in the shadow of a straight-edge. And even if you do get an accurate layout, it's difficult to cut to a line. Not to mention that a poorly lit shop can be downright dangerous as well.

Fortunately, there are some simple things you can do to shed more light in your shop. This can improve the quality of your work and make the shop safer as well.

**PAINT.** One thing that can help eliminate shadows is to paint the walls, ceiling, and pegboard a light color. This way, the light bounces off these surfaces instead of being absorbed by dark (or natural) colors.

Even so, you may still need additional lighting. To cover a range of situations, it's best to incorporate three types of lighting: natural light from a door or window, general area lighting, and lighting for specific tasks.

vides a true color. So it's ideal when mixing stains or testing the look of a finish.

But even sunlight has its drawbacks. If it shines directly on your work, the glare *obscures* details instead of highlighting them. To prevent this, just orient your work surface differently, see photo A.

## AREA LIGHTING

While natural light is nice, it's only part of the solution. Especially if your shop is in a basement or garage. To brighten up these areas, you'll need to use either incandescent or fluorescent light fixtures.

**INCANDESCENT.** Ordinary incandescent light bulbs are one of the most common ways to do this. But they produce more heat than light. So you can end up with some hefty electric bills. And the harsh shadows they cast often create a "blind spot." (For alter-

### A. Natural Light.

To take advantage of natural light, orient your bench or work surface so the sun slants across it at an angle.

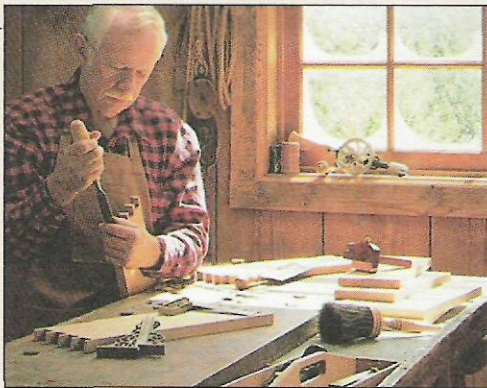

### B. Area Lighting.

Fluorescent shop lights are an inexpensive way to illuminate large areas of the shop.

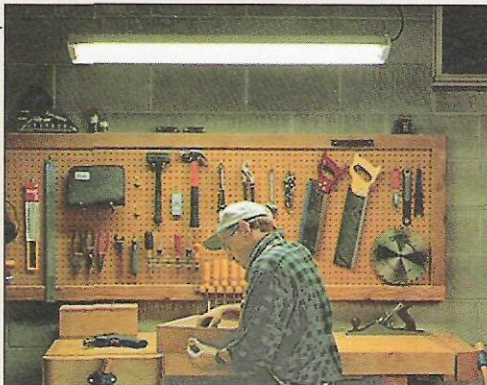

### C. Task Lighting.

When doing close-up work, individual "task" lights highlight small details that are difficult to see.

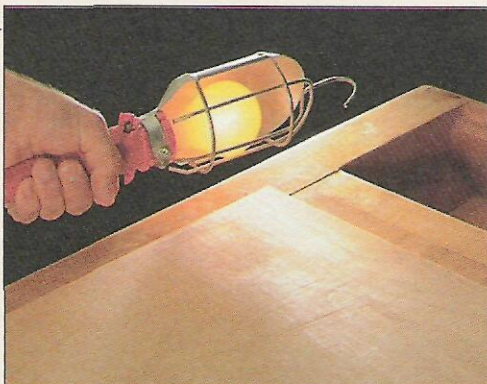

## NATURAL LIGHT

Besides giving the shop a comfortable "feel," natural sunlight pro-

## Alternative Bulbs

**COMPACT.** To reduce the amount of energy used, install a "compact" fluorescent bulb in an existing light fixture. Although it only uses 30 watts, this circular bulb produces the same amount of light as a 150 watt bulb.



**HALOGEN.** This halogen bulb produces about 10% more light than a standard incandescent bulb. And you get a brighter (white) light.

*Editor's Note: Both of these bulbs are available at most home centers.*



natives to standard incandescent light bulbs, see the box on page 22.)

**FLUORESCENT.** To provide a more diffused light, I use fluorescent fixtures, see photo B. The fluorescent shop lights you see at most home centers will handle the job. But the inexpensive ballasts in these lights can be a nuisance.

In cold weather, these ballasts may have a hard time starting the lamps. And the lamps flicker till the shop warms up. Not to mention that the "hum" of the ballasts is annoying. So even though they cost more, I check for ballasts that are designed to start in cold weather and run quietly.

**COLOR.** One last thing about fluorescent lamps is the *color* of

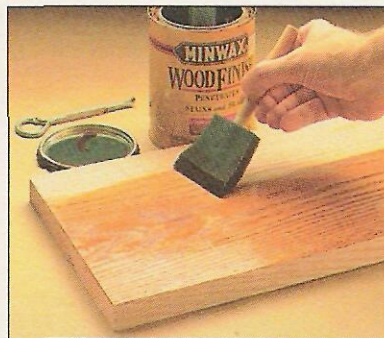
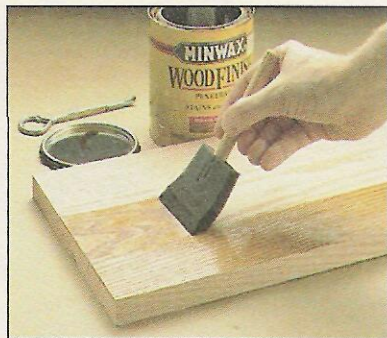

**Color.** Cool white or warm white fluorescent lamps produce a washed out color (left). But "full spectrum" lamps create a warm, natural-looking color (right). Just what you want above a finishing area.

the light produced. Most lamps have a blue or yellow cast to the light, see photos above.

That's fine for general purpose lighting. But where color is critical (like in a finishing area), it's worth using a "full-spectrum" lamp. (Four-foot lamps are available at home centers for about \$4 to \$6.)

**TASK LIGHTING**

Even in a well-lit shop, your body will still cast a shadow as you hunch over your work. Or a large tool will

create a dark spot. That's where task lighting comes in. It "fills in" shadows that make it hard to see.

**UTILITY.** Clip-on utility lights or lamps with magnetic bases (available in many woodworking catalogs) are an ideal way to focus light on a specific task, see photos at left. Or you can make a simple bracket and use an ordinary student lamp, see the box below.

But task lighting doesn't always involve getting *rid* of shadows. Before applying a finish for instance, shining a light at an angle across the surface *creates* shadows that reveal any irregularities, see photo C on page 22.



*If a fluorescent lamp breaks, a plastic sleeve will protect you from getting showered with glass fragments.*

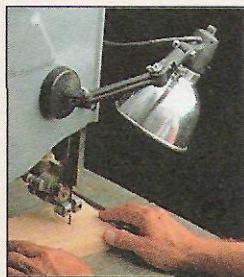
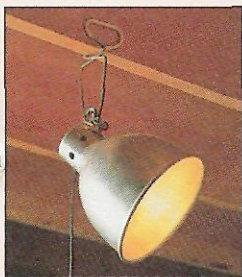

**Utility Lights.** A clip-on utility light (left) or a lamp with a magnetic base (right) help fill in shadows when you're doing close-up work.

**Shop-Made Lamp Bracket**

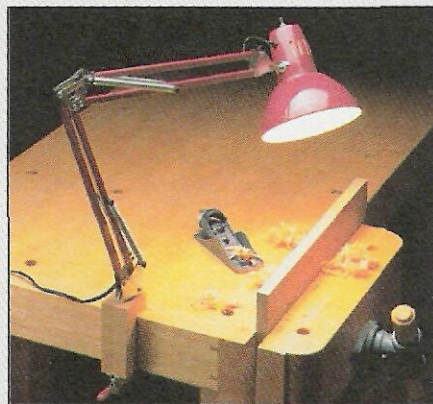
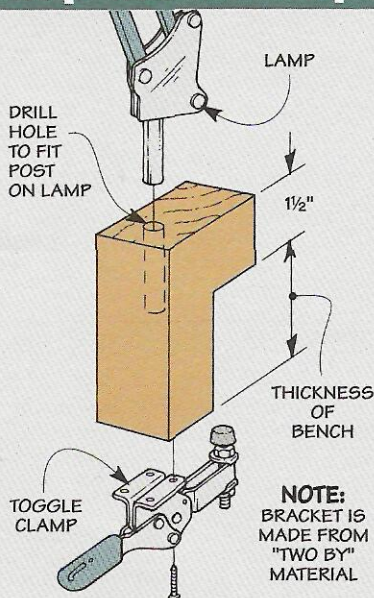

**Bench.** Clamping a shop-made bracket to the edge of your bench allows you to direct light from an ordinary student lamp exactly where you want it.

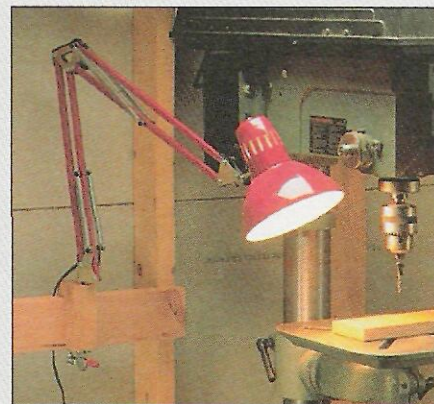

**Wall.** To illuminate close-up work at a power tool, clamp the bracket to a wall-mounted block ripped to the same width as the thickness of the bench.

# Combination Blades

*It's a "jack of all blades." But which combination blade is the best?*

**W**e have several specialty blades for the table saw in our shop. But the one that gets used day in and day out isn't a specialty blade at all—it's a combination saw blade.

Basically, it's designed to make a number of different types of cuts without changing blades. So you can rip a board one minute, crosscut (or miter) it the next, and still get good results.

**TEETH.** What makes this work is the design of the teeth. Not so much how they're arranged (in groups of five), but the *shape* of the teeth in each group.

For ripping, each group has one flat-topped tooth (raker) with a deep gullet in front for removing chips quickly, see drawing above. And to make smooth crosscuts, four teeth are angled across the top in alternating directions.

Okay, so it does a good job of

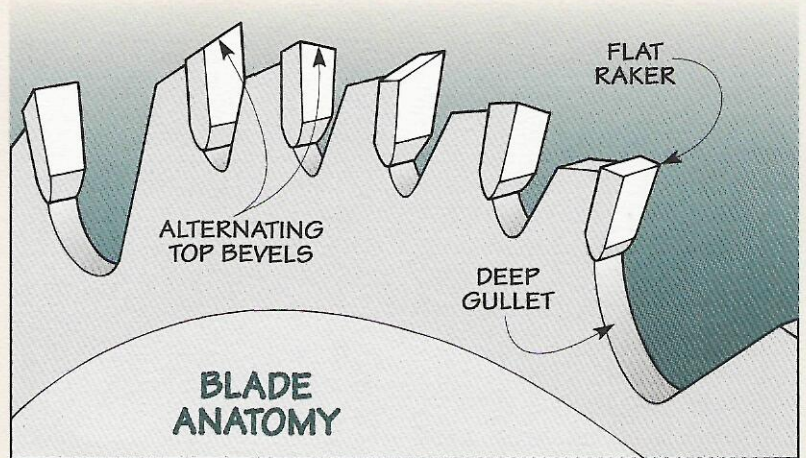

ripping and crosscutting. But which combination blade does the best job of both?

**TEST.** To find out, we tested six 10" industrial quality blades, see photos below. When selecting blades to test, we also noticed several "general purpose" blades. So we decided to test two of them as well, see box on next page.

**TEAM.** As with our other tool reviews, we rounded up our team of three woodworkers to test the blades. Once again, to provide a wide range of viewpoints, each person has a different level of woodworking experience.

So the "best" blade for a professional cabinetmaker like *Ken* may not be the one that *Cary* (a beginning woodworker) chooses. And an advanced woodworker like *Steve* may pick a different blade altogether.

**PROCEDURES.** While the final selections may vary, the test procedures were identical. The same contractor-style table saw was used throughout the test. (Using a dial gauge, we measured the runout of the saw at .0005".) And the same type and number of cuts



**CMT 110-500**  
(800-531-5559)  
\$62.90



**Delta 35-617**  
(800-223-7278)  
\$49.95



**Freud LU 84-10**  
(800-334-4107)  
\$49.95

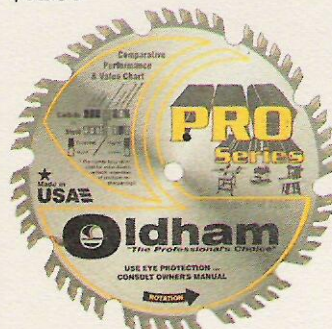

**Oldham C3470**  
(800-828-9000)  
\$44.95

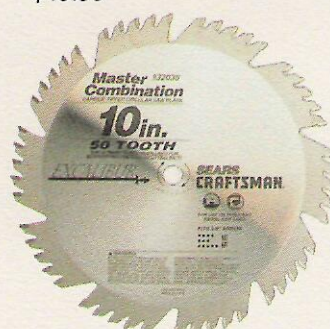

**Sears 932035**  
(800-290-1245)  
\$69.99



**SystiMatic**  
(800-426-0000)  
\$59.95



were made in hardwood, plywood, and particleboard. (For more on our testing procedures, refer to page 26.)

**Q:** Before making a single cut, you had a good chance to check out the blades. What do you look for in a quality blade?

**Ken:** The first thing is the carbide tips on the teeth. Although I can't determine the quality of the carbide, at least I can see the amount.

As a rule, the thicker the carbide, the more resharpenings I'm going to get. (See left-hand photo above.) Of the blades we tested, I liked the hefty carbide tips on the Freud and SystiMatic.

**Steve:** Another thing I check is how securely the carbide tips are attached. After all, with a blade whirling around at 100 mph and carbide tips slamming into a chunk of hardwood, something's going to give. Hopefully, it's the wood — not the carbide tips.

To make sure they stay put, they're brazed into "pockets"

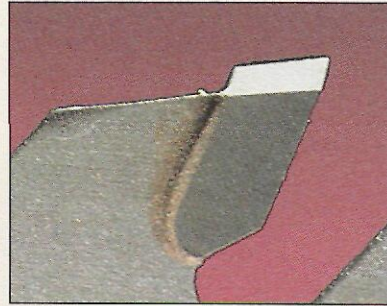

**Carbide.** Thicker carbide tips on the teeth of a blade will usually give you more resharpenings.

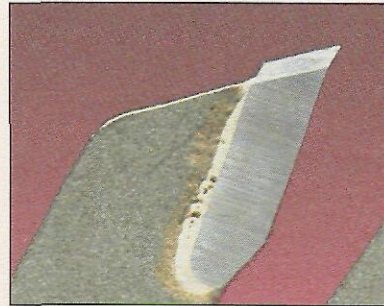

**Brazing.** Pinholes in the brazing that holds this carbide tip in place create a potential weak spot.



Cleaning up the brazing leaves a "glass bead" finish around the rim of the blade.

machined in the teeth. What I look for is a smooth, even bead without any pinholes. (See right-hand photo above.)

**Q:** Anything else about these blades that jumped out at you?

**Cary:** The outer rim of the blades appeared to be etched. (See top photo in margin.) At first, I thought it was to keep the blade from getting gunked up with pitch and resin. But I called up a technician at one of the companies and found it's more cosmetic than anything else.

The same is true for the "ring" on the body of the SystiMatic and Freud blades. (See bottom photo in margin.) This ring is what's left behind when the blade is tensioned to ensure it stays flat.

**Q:** So why doesn't the ring show up on the other blades?

**Cary:** It depends on what stage of the manufacturing process the tensioning is done. On the blades where you can't see the ring, the final grinding of the body is done after the tensioning. And this grinding removes the ring.

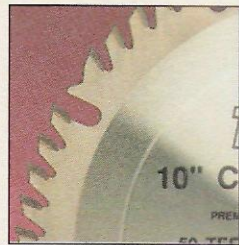

A faint ring is sometimes left over from the process used to tension the blade.

## General Purpose Blades

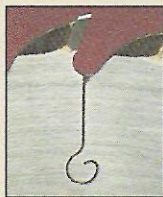

Although it does the same job as a combination blade, a *general purpose* blade goes about it differently.

**TEETH.** Take the teeth for instance. They're arranged evenly around the blade instead of in groups of five. And there are no flat-topped raker teeth.

Instead, *all* the teeth are beveled across the top in alternating directions, see drawing. This alternate top bevel (ATB) grind is similar to a crosscut blade. So we were curious to see if the DeWalt and Forreest blades we tested (see photos above right) would do a better job at crosscutting. (See page 27 for results.)

**EXPANSION SLOTS.** Another difference is the general purpose blades have a number of expansion slots cut into the body of the blade, see photo above.

Like the deep gullets in a combination blade, these slots allow the blade to expand and contract as it heats and cools. And this prevents the blade from warping.



**DeWalt 3213**  
(800-433-9258)  
\$45

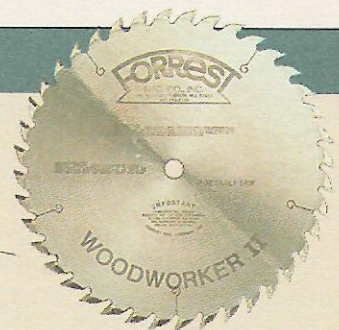

**Forreest Woodworker II**  
(800-733-7111)  
\$119.95

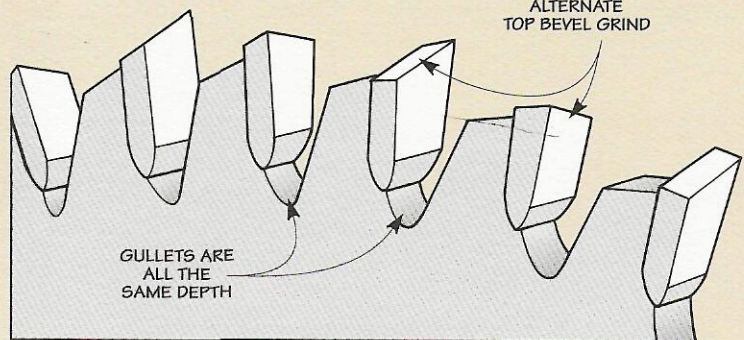

# Performance

**Q:** I'd expect all these saw blades to perform pretty well right out of the box. So how did you go about finding the one that was best?

**Steve:** By making all different types of cuts in all kinds of material. (See photos at right.) After all, a blade that produces a smooth edge when ripping might cause chipout when crosscutting.

**Cary:** Especially in plywood. And since many projects combine hardwood and plywood, I was anxious to see how using different materials affected the quality of cut.

**Ken:** A blade should stay sharp too — even if you occasionally cut abrasive material. So we cut up a sheet of particleboard with each blade and ran the test again.

**Q:** Was there any single type of cut (or material) where these blades just didn't measure up?

**Cary:** Crosscutting plywood — especially oak which tends to chip anyway. While the top side was almost perfect with no chipout, the bottom splintered

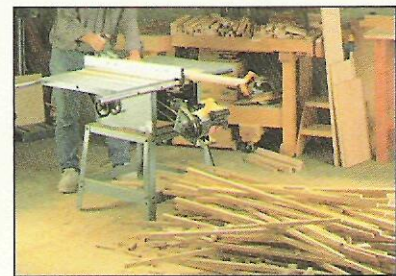

**How We Tested.** Besides crosscutting and ripping, we cut miters, bev-els, and compound miters (left). After checking the quality of cut in hardwood and plywood, we cut particleboard (right) and tested again.

like I'd cut it with a chain saw.

**Ken:** I'd say the problem isn't so much the blades as it is the blade height. (See box below.) With the height adjusted correctly, I got smooth cuts with each blade.

But one that made a slightly cleaner cut was the CMT. Probably because the raker teeth are chamfered. (See margin at left.) So they're not as likely to chip out fragile veneer when crosscutting.

**Q:** What type of results did you get when crosscutting hardwood?

**Cary:** That's where I noticed a big difference. When I crosscut a

board, all the blades except one left sawmarks on the end. But the Forrest blade practically burnished the end smooth. (See top left photo on next page.)

**Ken:** Two other blades that impressed me were the SystiMatic and Freud. Although the cuts weren't as polished, the ends were quite smooth. And the quality of cut didn't deteriorate after cutting particleboard like it did with the Delta blade.

**Q:** How do the rest of the blades stack up when crosscutting?

**Steve:** The Sears, CMT, and Oldham blades all made consistently good cuts. In fact, even when I used a magnifying glass, it was hard to find any significant differences.

**Q:** What did you find when cutting miters and compound miters.

**Ken:** I expected problems here. Especially since I was working with cherry which tends to burn. But all down the line, I got the same results as when crosscutting.

**Q:** How about ripping?

**Cary:** What surprised me is all the blades except one left ridges on the edge when ripping. (See top right photo on next page.) But with the Forrest, I got a smooth enough edge to use as a glue joint.

**Ken:** Don't forget. These blades are designed to do a good job with all types of cuts — not necessarily

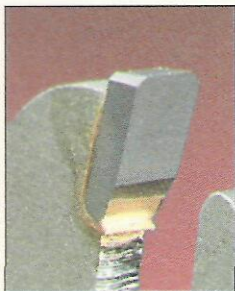

Chamfers on the raker teeth of the CMT blade help prevent chipout.

## Cutting Plywood

It's possible to get a clean, crisp cut in plywood when using a combination (or general purpose) blade. But only if the height of the blade is adjusted correctly.

With the blade raised high, the teeth cut at an angle that's almost perpendicular to the plywood, see left-hand drawing below. So there's no chipout on top. But as the blade exits the bottom, it blows out the veneer.

To get around this, raise the blade

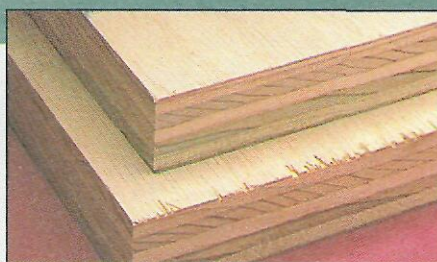

$\frac{1}{8}$ " above the plywood. This way, the teeth make a shearing cut and don't chip out the bottom, see right-hand drawing below.

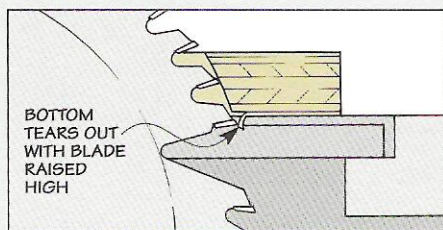

to excel at one. I can live with a few ridges. I'd just rip the board a hair wider and run the edge across a jointer.

**Q:** One thing I'm curious about is the different "look" of the Freud and CMT blades. What gives?

**Steve:** You mean the tall shoulder that sits behind each set of teeth? (See left-hand photo below.) It limits kickback by making the blade take a smaller "bite."

That's a nice safety feature if you get kickback caused by feeding the workpiece too fast. But I

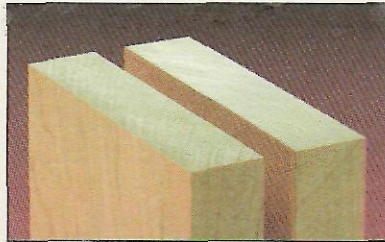

**Crosscut.** When crosscutting, the Delta blade left sawmarks (left) while the Forrest polished the end (right).

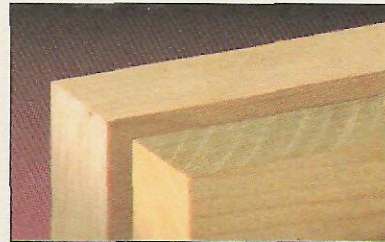

**Rip.** Most blades left ridges on the edge when ripping (bottom) that need to be jointed smooth (top).

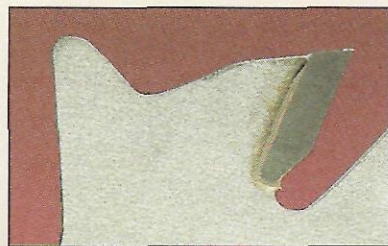

**Anti-Kickback.** A shoulder behind each set of teeth on the Freud and CMT blades helps limit kickback.



**Noise Reduction.** Slots in the CMT blade are filled with a special material that reduces noise.

**Q:** And what about the slots cut in the body of the CMT blade?

**Ken:** They're supposed to absorb vibration and make the blade run quieter. (See photo at left.) And if you go by the "thunk" you hear when you flick the blade with your finger, it should work.

To find out, I borrowed a meter that's used to measure sound. What I found is the CMT was two decibels quieter than the other blades when ripping 1½"-thick maple. But at 99 decibels, it's still too loud to cut without hearing protectors.

## Recommendations

**Ken:** To be honest, I'd be satisfied with any of these saw blades. But I picked the SystiMatic as the best.

Whether crosscutting or ripping, it gave me a *slightly* cleaner cut than any other blade except the Forrest. Yet it costs half as much.

A second choice? Probably the Freud. It's a good quality blade for a little less money.

**Steve:** Eliminating three blades is easy. The Forrest is too expensive. And the Delta and DeWalt don't give me as smooth a cut as I want.

Then things get tough. I can make a perfectly good joint with either the CMT, Sears, or Oldham. But the SystiMatic and Freud have a slight "edge" in price and quality, so I chose them instead.

**Cary:** The way I look at it, buying a saw blade isn't all that different than any other tool. Quality means more to me than price.

So I picked the Forrest blade because of its quality of cut. Polished ends when crosscutting. And when ripping, it leaves edges smooth enough to glue up. That's nice since I don't have a jointer. 🐿

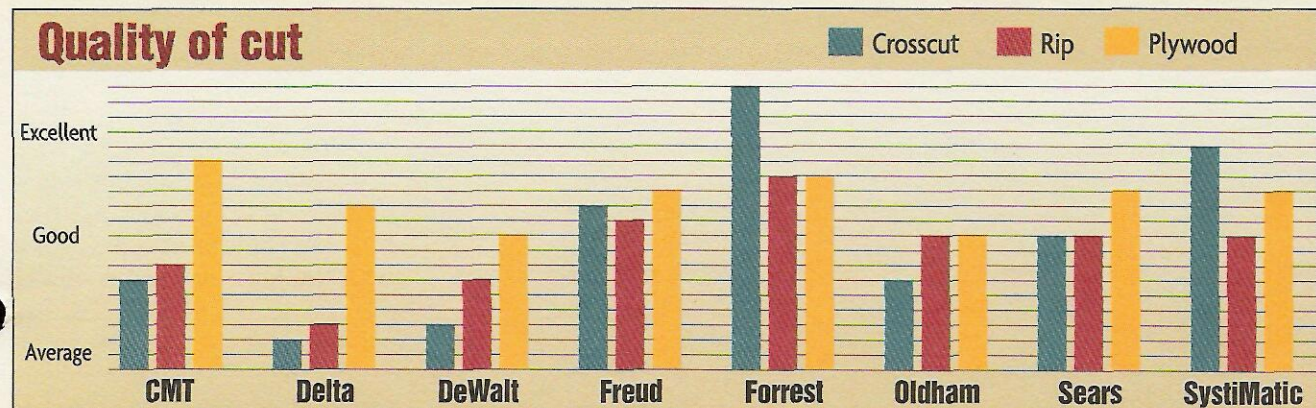

# Shop Solutions

## Spindle Adjustment Knob

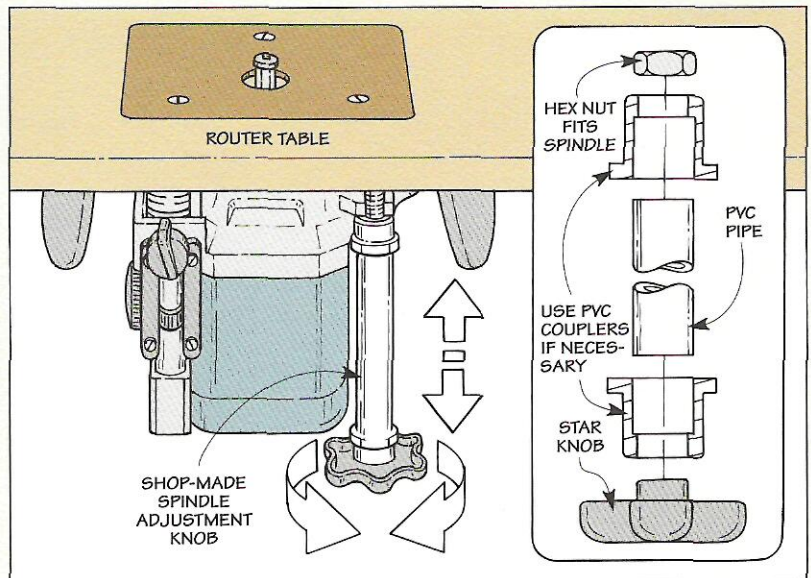

■ The most convenient way to adjust the depth of cut in a plunge router installed in a router table is with a spindle adjustment knob, see photo. Unfortunately, they're usually sold as an accessory and

can cost over \$20. I got the idea to make one when I came across some scraps of PVC pipe.

Start by epoxying a hex nut that fits the spindle of your router into a short length of PVC

pipe, see drawing. Then epoxy a plastic star knob to the other end of the pipe to make it easy to turn (total cost, less than \$5).

*Kevin Masten  
Kansas City, Missouri*

## Belt Sander Platform

■ When using the *belt sander* on my stationary sander, the guard on the *disk sander* tends to get in the way. To get around this, I built a plywood platform to fit the belt sander's table top and made it tall enough to clear the top of the disk sander guard, see drawing.

The only trick was attaching the box to the table top. I didn't want to use clamps because they'd be in the way. And bolting it in place would have made it a hassle when installing or removing it. So instead, I came up with an expanding cleat, see detail.

The cleat is cut to fit the miter gauge slot in the table top and is screwed to the bottom of the box. But before screwing it in place, I

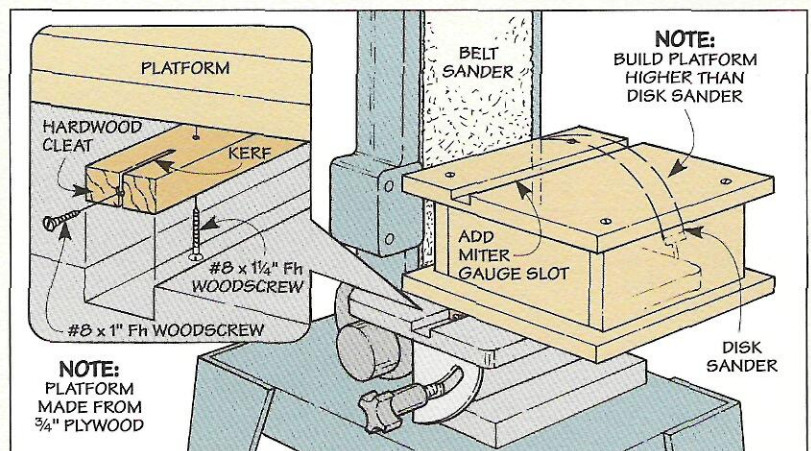

cut a thin kerf in each end and installed a screw in the center of each kerf.

To use the box, first slide the cleat in the miter gauge slot.

Then tighten the screws. The screws spread the kerf and lock the cleat tightly in the slot.

*Robert H. Raquet  
Norristown, Pennsylvania*

## Checking Diagonals

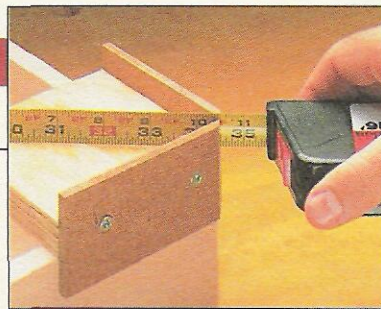
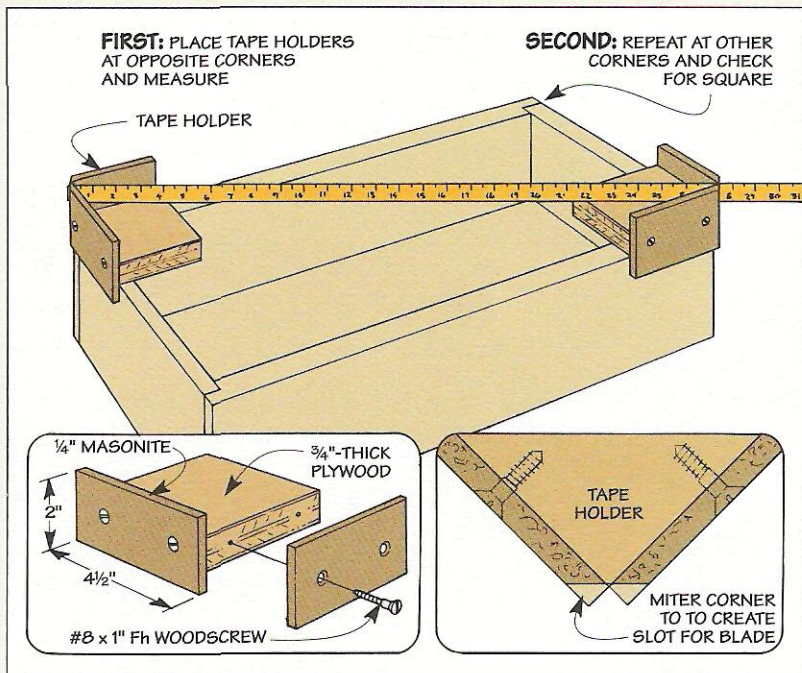

■ Comparing the diagonals of a cabinet is a great way to check it for square. But when alone in the shop, measuring long diagonals can be difficult. To give me a hand, I made a pair of simple tape holders, see photo.

Each holder is just a scrap of plywood with two sides covered with Masonite to “hook” over a corner, see drawing. Then to hold the tape and allow for an accurate reading, the corner is mitered to form a slot that fits the blade.

*R.B. Himes  
Vienna, Ohio*

## Keyhole Slot Tip

■ Many woodworkers have discovered that a keyhole slot routed in the back of a picture frame is a great way to hang the frame on a wall. But unless the slot is routed exactly in the center of the frame, the frame is going to hang crooked.

To avoid this, I rout the slot *horizontally* to allow the frame a small amount of side-to-side adjustment, see drawing.

*Joseph Kutchma  
Kewanee, Illinois*

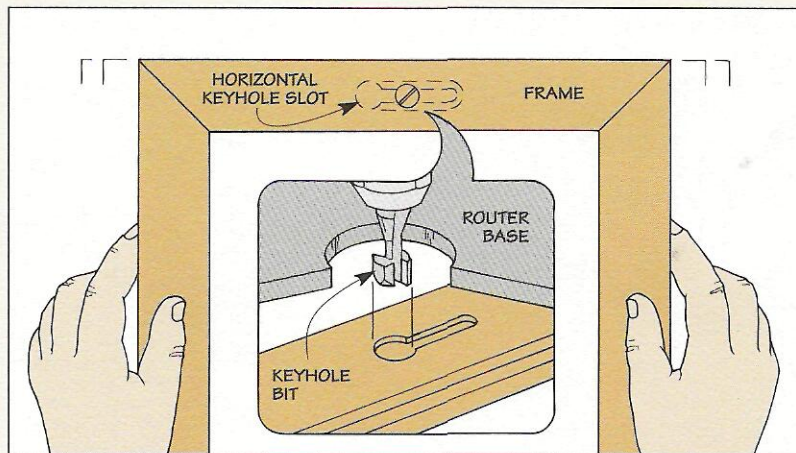

## Cord Wrap



■ To keep power cords rolled up when not in use, I keep them tied with elastic ponytail holders. The best holders I've found for this are the type with a small plastic ball at each end, see photos.

You can find them anywhere beauty supplies are sold for around \$1.50 for a package of six.

*John Harlan  
Logan, Utah*

## Send in Your Solutions

If you'd like to share your original solutions to problems you've faced, send them to: *ShopNotes*, Attn.: Shop Solutions, 2200 Grand Avenue, Des Moines, IA 50312. (Or if it's easier, FAX them to us at: 515-282-6741.)

We'll pay up to \$200 depending on the published length. Please include a daytime phone number so we can call you if we have any questions.

# Rubbing Out a Finish

**T**he secret to getting a “perfect” finish isn’t how you *apply* the finish. It’s what you do *after* it dries. That’s where rubbing out the finish comes in.

By removing flaws in the finish caused by dust particles or brush marks, it makes a finish *feel* smoother. And it improves the *look* of a finish by creating a nice, even sheen (either satin or gloss).

**BUILD FINISH.** But before you get started, you’ll need to build up the thickness of the finish. How thick? That depends on the finish and how much sanding you do between coats. I usually apply five or six coats.

**WAIT.** Although it may be tempting to rub out the finish as soon as the final coat dries, it’s best to wait awhile. By giving the finish time to harden (at least a week, but a month is better), you’re more likely to get a uniform sheen.

**ABRASIVES.** When it’s time to rub out the finish, the basic idea is simple. You’re using a series of progressively finer abrasives to create a pattern of tiny scratches — just like sanding a board.

The size of these scratches determines how much light is reflected. So depending on where

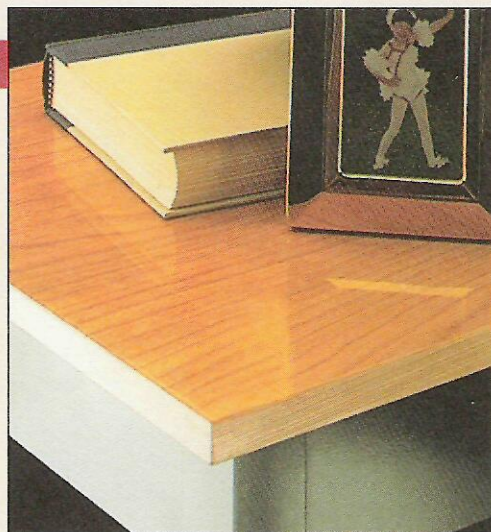

you stop in the process, you can either get a satin or gloss finish.

**SANDPAPER.** Regardless of the look I’m after, I start by sanding the finish with 1000-grit silicon carbide sandpaper, see Step 1. A film of soapy water helps keep the sandpaper from clogging. And a rubber sanding block ensures a flat surface.

The thing to watch is that you don’t accidentally cut through the finish. So check your progress frequently and continue to sand until you get a dull, uniform sheen, see Step 2.

**PUMICE.** Next, to bring out a satin sheen, I switch to a powdered abrasive called pumice, see Sources in margin. Here again, use soapy water and sprinkle on the pumice (a salt shaker makes a handy applicator). What works best for me is to use a felt block to rub the pumice evenly across the surface, see Step 3.

**ROTTENSTONE.** After you’ve wiped off the remaining pumice and checked for a consistent sheen, you may want to use rottenstone to rub the finish to a high gloss. It’s applied the same way. But it makes smaller scratches that create a shinier surface.

**POLISH.** Finally, to get a mirror-like surface, you can apply a polishing compound and buff it out, see Step 4. One that I like (*Behlen’s Deluxing Compound*) combines rottenstone, an even finer abrasive (tripoli), and two types of wax. 

## Sources

- Homestead Finishing Products (pumice, rottenstone) 216-582-8929
- Garrett Wade (pumice, rottenstone, polishing compound, felt blocks) 800-221-2942
- Woodworker’s Supply (pumice, rottenstone, polishing compound, felt blocks) 800-645-9292



**Step 1.** With soapy water as a lubricant, use Wet-or-Dry sandpaper and a rubber block to sand the finish flat.



**Step 2.** Remove the slurry with a squeegee and check for a dull, uniform sheen. Shiny areas indicate low spots.



**Step 3.** Now rub the finish with pumice and a felt pad to produce a satin sheen. Rottenstone creates a gloss finish.

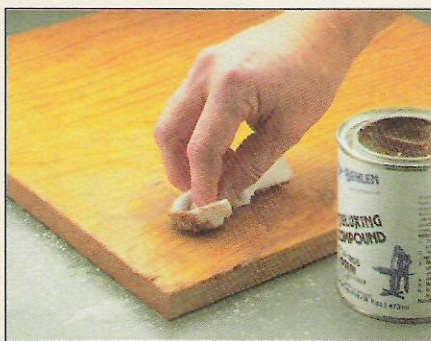

**Step 4.** To get an even shinier finish, apply a polishing compound in a circular motion. Then buff it out when dry.

# Specialty Plywoods

*Here are three special types of plywood that have been engineered for specific uses.*

## Medium-Density Overlay

■ Medium-density overlay (MDO) is a plywood product that's ideal for outdoor projects, see photo. In fact, many of the green road signs you see along Interstate Highways are made of MDO.

MDO is basically a B-grade plywood free of voids with one or both faces covered with a smooth paper overlay. This overlay is impregnated with phenolic resins to make the plywood abrasion and

water resistant (not waterproof).

A sheet of single-faced  $\frac{3}{4}$ "-thick MDO (G1S - good one side) can cost anywhere from 25% to 50% as much as its AC grade plywood counterpart. Double-faced MDO (G2S) is about \$10 more per sheet than single-faced MDO.

Note: Even though MDO is water resistant, it should be primed and painted with an exterior paint (especially the edges).



## Premium Plywoods

■ At first glance, ApplePly (see photo) and Baltic Birch appear like any other plywood. It's not until you look at the *edges* that you'll notice a difference. These plywoods have roughly twice the number of plies than standard plywood — which makes them extremely stable.

For jigs and fixtures, I prefer Baltic Birch (birch throughout) because it's the least expensive of

the two. When it comes to furniture and cabinetry, ApplePly (alder inner plies) is a better choice because of the large selection of face veneers and grades. It machines very well and can be routed.

Because Baltic Birch is made in Europe and Russia, it only comes in metric sizes. ApplePly on the other hand is made in the U.S., and is available in standard thicknesses from an  $\frac{1}{8}$ " to 1".

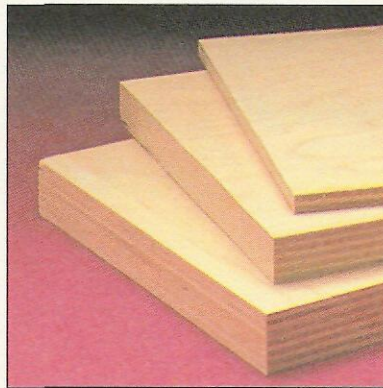

## Bending Panel

■ The first time I saw a sheet of Bending Panel bent into a tight radius I was impressed. It's a flexible plywood product manufactured by the Danville Plywood Corporation (often sold as Curve-A-Board), see photo.

The secret to bending without breaking is the thickness of the plies and the direction they run. The panel shown has a  $\frac{1}{32}$ "-thick center ply that holds two thicker

plies together — with the grain of the center ply running perpendicular to them.

Although not intended to be used as a structural material, Bending Panel is used decoratively for curved panels. According to the manufacturer, it's designed to be bent to a radius of 16". And is available in  $\frac{1}{8}$ ",  $\frac{1}{4}$ ", and  $\frac{3}{8}$ " thicknesses, with a birch, maple, or pine veneer.

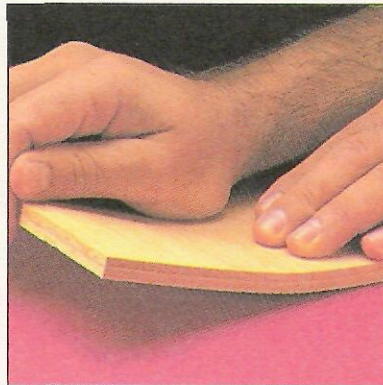

### Sources

- Because these are considered specialty plywoods, not all lumberyards are going to have them in stock, but many will special order them for you.
- For your nearest ApplePly dealer call: States Industries at 800-626-1981

## Scenes from the Shop

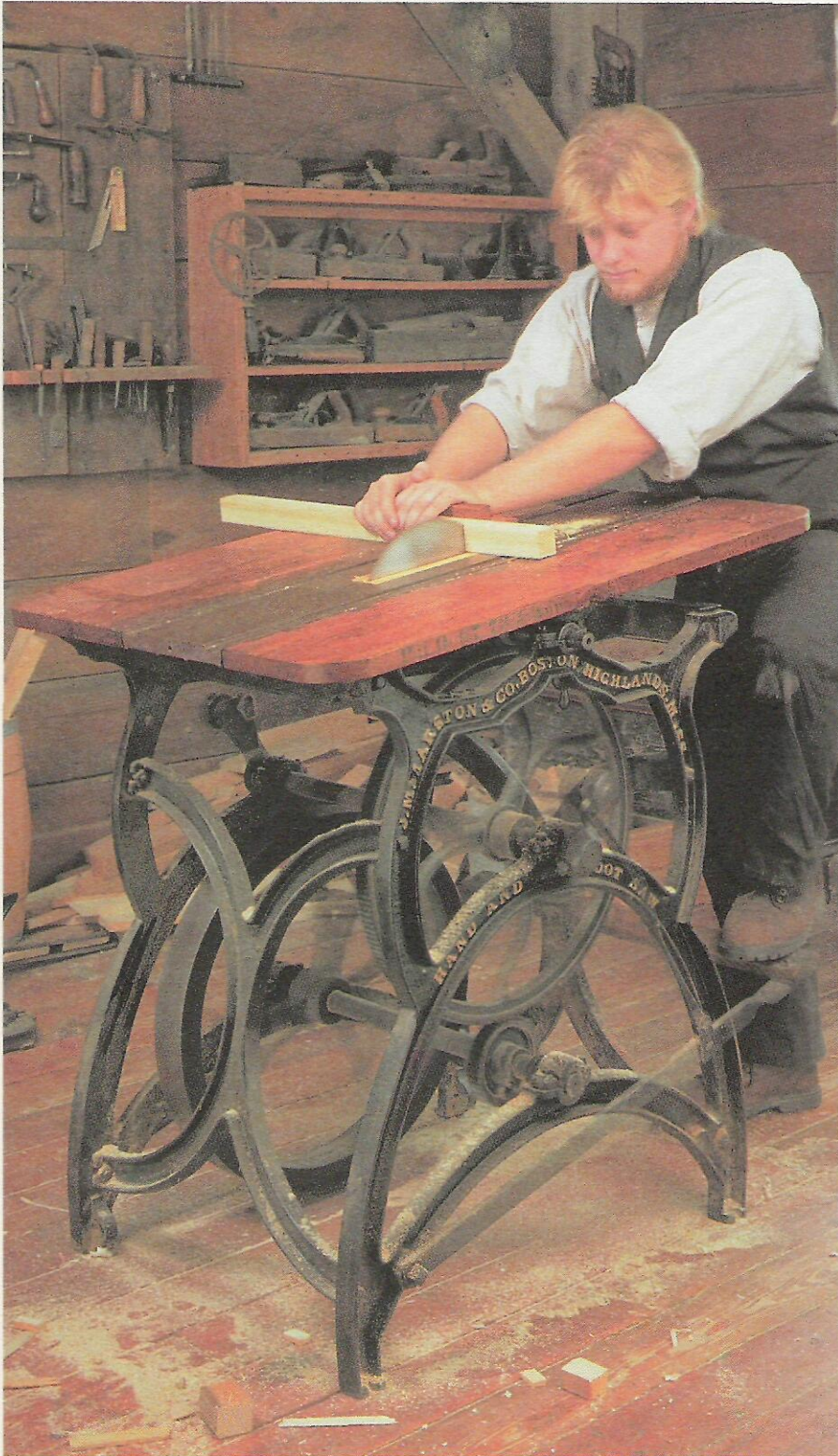

▲ Built by the J.M. Marston & Company, this 1873 forerunner of today's table saw is used in a turn of the century shop at Des Moines' Living History Farms. After tilting the table to adjust blade height, the saw blade is rotated by stepping on a foot pedal, or having a helper use an optional hand crank.

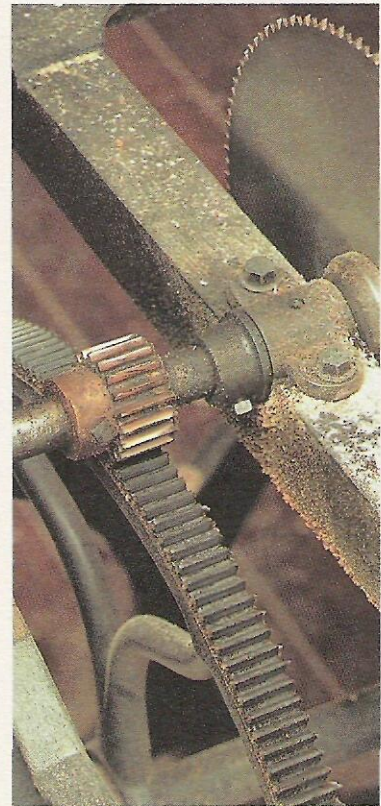

▲ A simple set of gears transfer the momentum of the spinning flywheel directly to the arbor the saw blade is mounted on.



▲ By turning this small hand-wheel under the front edge of the table, the top is raised and lowered instead of the blade.