

TIPS • TOOLS • TECHNIQUES

ShopNotes®

Vol. 5

Issue 27



SLIDING Cutoff Table

- Scraper Plane
- Outdoor Finishes
- Picnic Table
- Pegboard Storage Rack
- Splined Miter Joinery

PUBLISHER Donald B. Peschke
EDITOR Tim Robertson
ASSOCIATE EDITOR Phil Totten
CONTRIBUTING EDITORS Vincent S. Ancona
 David Stone
ART DIRECTOR Cary Christensen
SENIOR ILLUSTRATORS Kurt Schultz
 Roger Reiland
 Mark Higdon

CREATIVE RESOURCES

Creative Director: Ted Kralicek • *Exec. Editor:* Douglas L. Hicks • *Project Design Director:* Ken Munkel • *Sr. Proj. Designer:* Kent Welsh • *Shop Manager:* Steve Curtis • *Shop Craftsman:* Steve Johnson • *Sr. Photographer:* Crayola England • *Elect. Comm. Coord.:* Gordon C. Gaipe • *Assoc. Graphic Design Dir.:* Susie Rider • *Senior Graphic Designer:* Chris Glowacki • *Graphic Designer:* Cheryl L. Cynor

CIRCULATION

Circulation Director: Susan Du Bois • *Assistant Circ. Dir.:* Troy Dowell • *Subscription Managers:* Sandy Baum, Paige Rogers • *Asst. Sub. Mgr.:* Julie Greenlee • *Newsstand Mgr.:* Kent A. Buckton

CORPORATE SERVICES

VP, Planning & Finance: Jon Macarthy • *Controller:* Robin Hutchinson • *Sr. Acct.:* Laura Thomas • *Bkpr.:* Holly Lucas • *Prod. Dir.:* George Chmielarz • *Prod. Mgr.:* Carol Quijano • *Elect. Pub.:* Douglas M. Lidster • *Prod. Artist:* Jon Snyder • *Net. Adm.:* Al Barnes • *Prof. Develop. Dir.:* Joyce Moore • *Admin. Assists.:* Cheryl A. Lee, Julia Fish • *Receptionist:* Jeanne Johnson • *Bldg. Maint.:* Ken Griffith

MAIL ORDER

Op. Dir.: Bob Baker • *Art Dir.:* Cindy Scarpino • *Materials Mgr.:* Mark Mattussi • *Cust. Serv. Mgr.:* Jennie Enos • *Warehouse Super.:* Nancy Johnson • *Buyer:* Linda Jones • *System Op.:* Tammy Aldini • *Team Leader:* Karla Cronin • *Tech. Support:* David Stone • *Cust. Serv. Reps.:* Jennifer Murphy, Joy Krause, Sara Kono, Anna Cox, Adam Best, Kristi Andrews, Margo Petrus • *Warehouse:* Gloria Sheehan, Chuck Carlson, Sylvia Carey, Larry Prine, Scott Gilliam, Cathy Steiner

ShopNotes® (ISSN 1062-9696) is published bimonthly (Jan., March, May, July, Sept., Nov.) by August Home Publishing, 2200 Grand Ave., Des Moines, IA 50312. ShopNotes® is a registered trademark of August Home Pub. ©Copyright 1996 by August Home Publishing. All rights reserved.

Subscriptions: Single Copy, \$4.99. One year subscription (6 issues), \$19.95. Two years (12 issues), \$35.95. Canada/Foreign, add \$5.00 per year.

Second Class Postage Paid at Des Moines, IA and at additional offices.

Postmaster: Send change of address to ShopNotes, Box 11204, Des Moines, IA 50340-1204

Subscription Questions? Call 1-800-333-5854, 9am to 5pm, Central Time, weekdays. FAX 515-283-5854

E-Mail: ShopNotes@aol.com

Internet: http://www.augusthome.com

PRINTED IN U.S.A. Reprinted 2003

Cutoffs

It doesn't take much detective work to identify the scraper I use in the shop. It's the one with the rusty thumbprints imprinted on the blade. While the rust is just part of living in a humid area, the thumbprints tell a much different story.

They're a visual reminder of the constant (and tiring) hand pressure it takes to keep the scraper flexed when smoothing a surface. Not to mention the heat that builds up that can make it downright uncomfortable to hold.

SOLUTION. That's why I was excited when Ken (our design director) showed me the scraper plane he was working on for this issue. It holds a scraper at a constant angle and flexes the blade at the same time. So I can make thin, wispy shavings with a lot less effort. And I don't leave any fingerprints on the scraper.

SMALL PIECES. Because the scraper plane is built up from pieces that are quite small (see photo), one of the challenges is to find a safe and accurate way to cut them. So even if you don't plan on building the plane, it's worth taking a look at the article on page 4 to check out the tool setups and jigs we used to work with the small pieces.

LARGE PIECES. Cutting large pieces also presents its share of problems — especially on the table saw. For example, think back to the last time you used a miter gauge to crosscut a wide panel.

What probably happened is you had to pull the miter gauge so far back in front of the saw that the head no longer supported the workpiece. Or maybe the end of the runner came clear out of the

slot. Either way, it makes it impossible to get an accurate cut.

CUTOFF TABLE. This is where a sliding cutoff table like the one shown on page 16 comes in handy. Basically, it's a big platform that works like a huge miter gauge. But what's different is you can make extremely accurate crosscuts on panels up to a full 24" wide.

Besides its extra-large capacity, there were several other things on my wish list as the sliding table was in the design stage. Like

having a fixed fence (for 90° cuts) and an adjustable fence for making angled cuts. A stop block for making repeat cuts accurately. A replaceable insert to reduce chipout. And a ...

ANTICIPATION.

Okay, I'll stop there.

The point is I look forward to each new project like the first balmy days of spring after a long winter. And it doesn't always have to be a woodworking project.

A CHANGE. Recently, I've picked up the responsibilities of Editor here at ShopNotes. Although the job is new, I've been around ShopNotes since Issue No. 1, so I feel right at home.

And I'm as excited about the upcoming issues as when I first came on board. As always, we'll continue to feature the practical tips and techniques, unique project ideas, and unbiased tool reviews that you've come to expect.

In the meantime, don't be a stranger. Stop by for a visit. Drop me a line (or photo) about the latest project you're working on. Or send along a tip that you'd like to see published. I look forward to hearing from you.



Tim

WoodNet

COMPUTER BULLETIN BOARD FOR WOODWORKERS

- Project plans and photos to download
- Woodworking Techniques Forum
- Indexes for Woodsmith & ShopNotes
- FREE download on first call

To log on to WoodNet, call 1-515-245-9663. If you have any questions, please give us a call: (voice) 1-515-282-7000 M-F 9-5 CST.

Contents

Projects & Techniques

Scraper Plane _____ 4

Designed to hold an ordinary steel scraper, this shop-built plane makes it easy to get a smooth, uniform surface.

Splined Miters _____ 8

Here's a simple technique that adds lots of strength to your miter joints. Just rout a slot and glue in a spline.

Picnic Table _____ 10

With splined miters and a "shortcut" version of a mortise and tenon, this good-looking picnic table is built to last.

Sliding Cutoff Table _____ 16

Cut wide glued-up panels or pieces of plywood safely and accurately with this sliding cutoff table. And an adjustable fence allows you to make angled cuts as well.

Drilling Holes for Screws _____ 22

There's more to drilling holes for screws than meets the eye. The key is the size and sequence you drill the holes.

Departments

Great Tips Plywood Tips _____ 14

A collection of our best tips for working with plywood.

The Small Shop Pegboard Storage _____ 24

Lots of storage in a compact space. That's the idea behind the unique design of this pegboard storage system.

Selecting Tools Quick Clamps _____ 26

We test three different "quick clamps" and offer practical suggestions on which one to choose.

Readers' Tips Shop Solutions _____ 28

Our readers offer their own shop-tested solutions to some of the most common woodworking problems.

Lumberyard Redwood _____ 30

Building a project out of redwood? Understanding the different grades can affect both its cost and durability.

Finish Room Outdoor Finishes _____ 31

A look at three finishes that resist the extremes of weather.

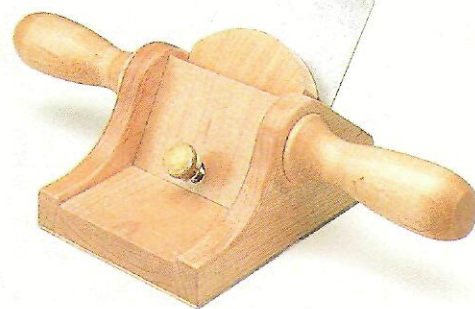

Scraper Plane page 4

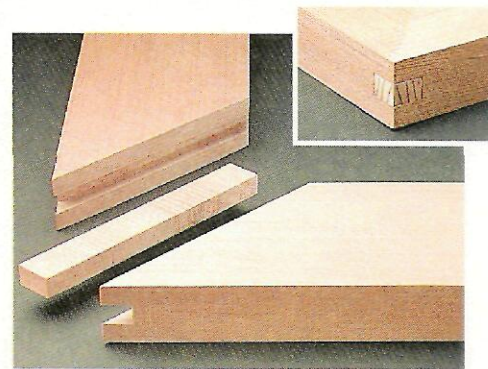

Splined Miters page 8

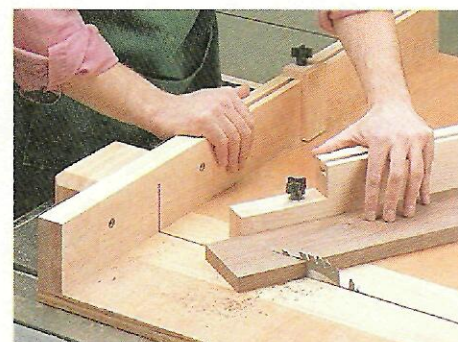

Sliding Cutoff Table page 16

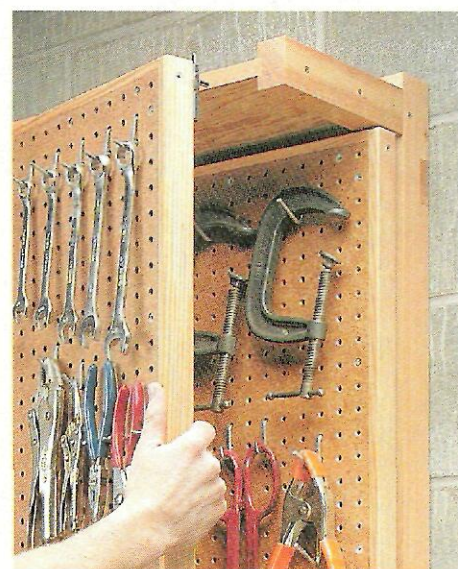

Pegboard Storage page 24

Scraper Plane

This shop-built plane solves two of the biggest problems of using a hand-held scraper.

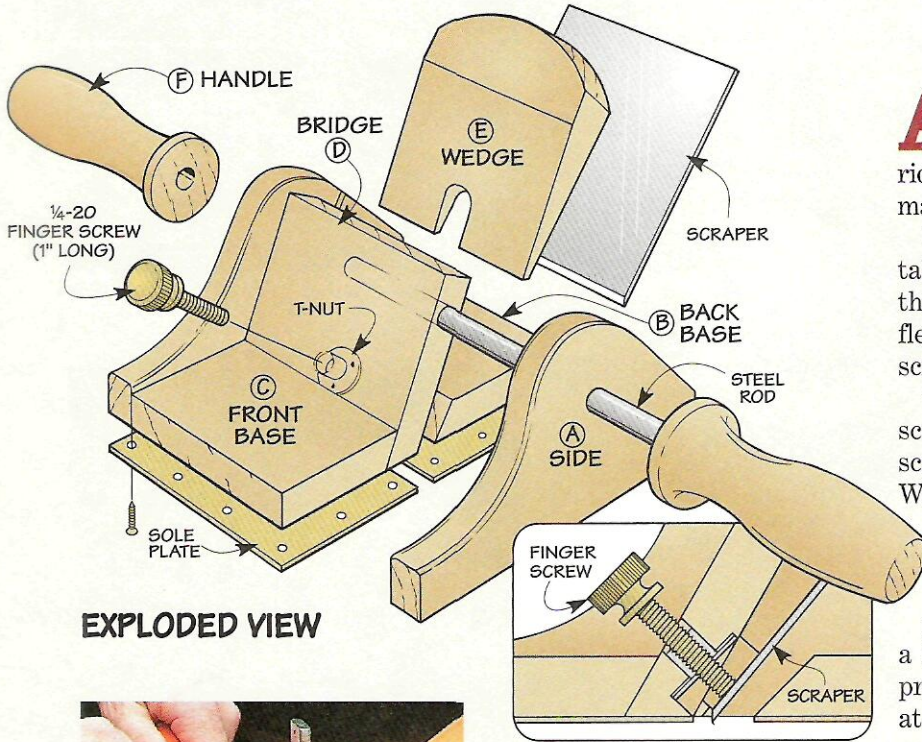
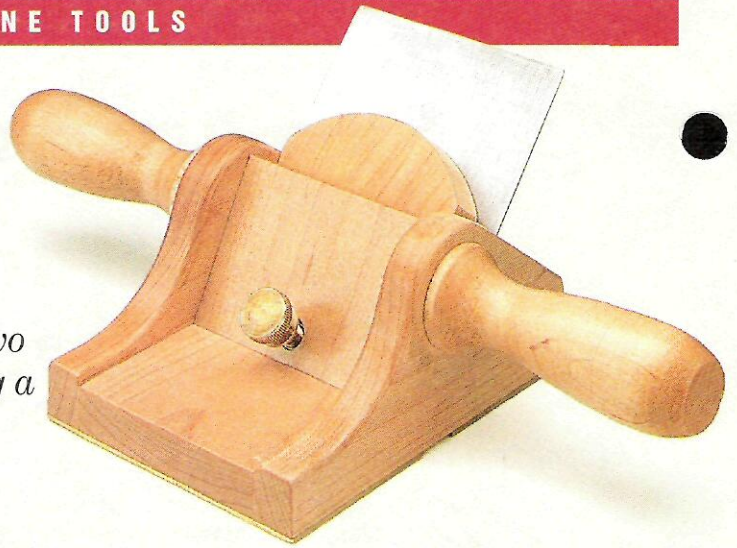

EXPLODED VIEW

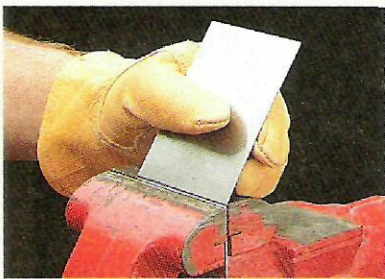
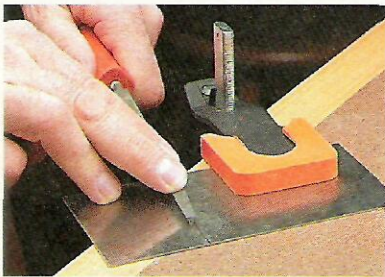

Cutting a Scraper. After filing a deep groove across the blade (top), tighten the scraper in a vise and bend it until it snaps (bottom).

A thin piece of steel. That's all there is to a scraper. Yet it's an ideal tool for leveling ridges left behind by a planer, removing burn marks, or smoothing highly figured pieces of wood.

But as much as I like using a scraper, it doesn't take long before my thumbs start to wear out from the constant pressure required to keep the blade flexed. And the heat caused by the friction from scraping makes the blade uncomfortable to hold.

This scraper plane changes all that. It holds the scraper at a consistent angle. And a simple finger screw adjusts the amount of flex in the scraper. With a pair of handles providing a firm, comfortable grip, you can make thin, wispy shavings all morning long without tiring.

SCRAPER. Before you get started on the plane, it's best to have the scraper in hand. I used a 3"-wide scraper. Then, to create a low overall profile, I cut the scraper to a length of 4", see photos at left. (For a complete hardware kit, see page 5.)

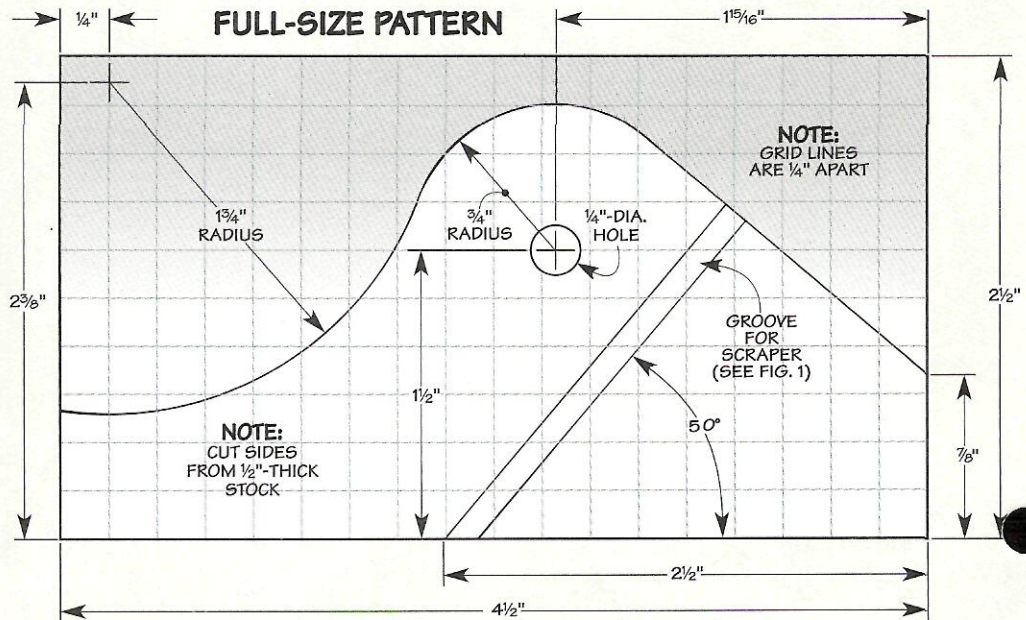

SIDES. I began by making the curved sides of the plane from two 1/2"-thick blanks, see Fig. 1 and the full-size pattern on page 4. (I used maple, but it's also a good chance to experiment with a piece of highly figured wood, refer to the photos on back page.)

GROOVES. To hold the scraper in the plane, an angled groove (kerf) is cut on the inside face of each blank, see Fig. 1b. Note: You'll need to move the miter gauge to the opposite slot and rotate the head to the opposite angle to cut the groove in the second blank.

To ensure the grooves align when the plane is assembled, I

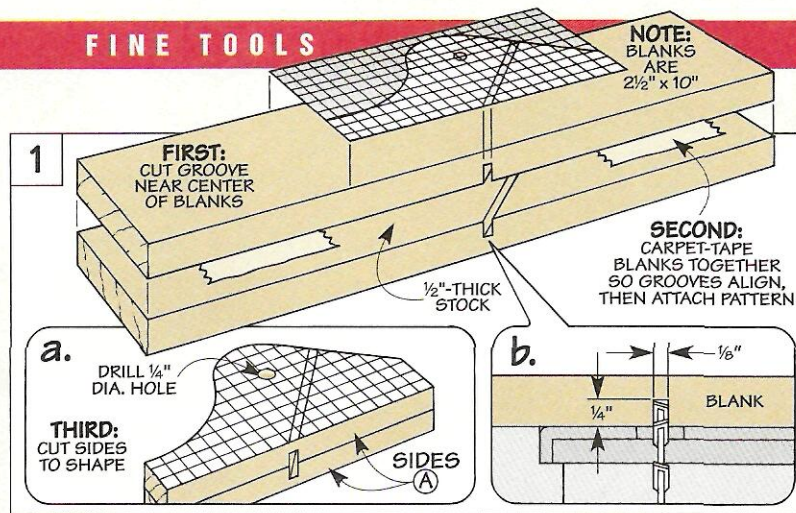

carpet-taped the blanks together so the kerfs match up and attached the paper pattern with spray adhesive. Then, after cutting and sanding the *sides* (A) to shape, drill a

hole for a steel rod that's added later, see Fig. 1a.

All that's left is to take the sides apart and rout a slight (1/8") roundover on the top edges only.

Core

With the sides complete, you can start on the core of the plane. It's made up of two base pieces that form the bottom of the plane, and a bridge that supports the handles and holds the sides together, see Exploded View on page 4.

BLANK. Since these pieces are fairly small, it's safest to cut them from one long blank, see drawing.

The beveled end on the *back base* (B) will keep shavings from clogging the plane. And cutting a single bevel to separate the *front base* (C) from the *bridge* (D) ensures a tight joint when these

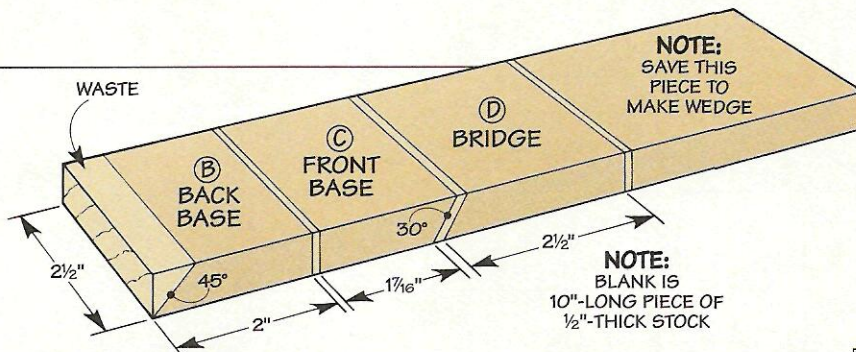

pieces are glued up. Note: Save the remaining part of the blank to use for the wedge later.

T-NUT. There's one last thing to do before assembling the core. To accept a T-nut and thumbscrew that work together to flex the scraper, a counterbored shank

hole is drilled at an angle in the bridge, see Figs. 2 and 2a. Note: A pair of cleats keeps the bridge from sliding as you drill the hole.

ASSEMBLY. After epoxying the T-nut in place (Fig. 2b), it's just a matter of gluing up the sides and core pieces. The front base and bridge are glued together first, see drawing below. Then this assembly and the back base are sandwiched between the sides.

Hardware

- (1) 1/4" T-Nut
- (1) 1/4" x 1" Knurled Finger Screw (Brass)
- (20) #4 x 1/4" Fh Woodscrews (Brass)
- (1) 2" x 12" Brass Plate (.064 thick)
- 1/4" x 6 1/2" Steel Rod
- 3" x 6" Scraper

For a complete hardware kit, call 800-347-5105 6827-100.....\$19.95

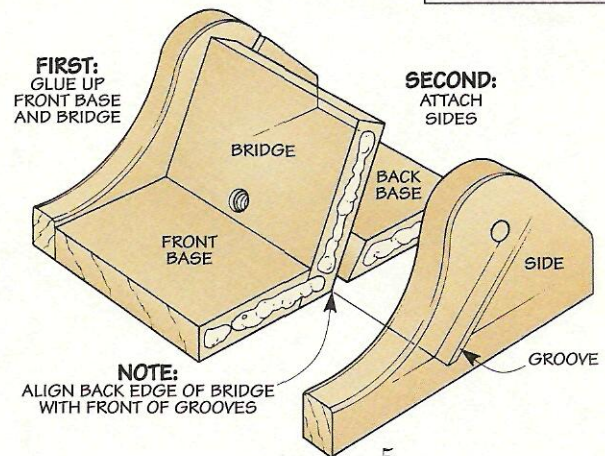
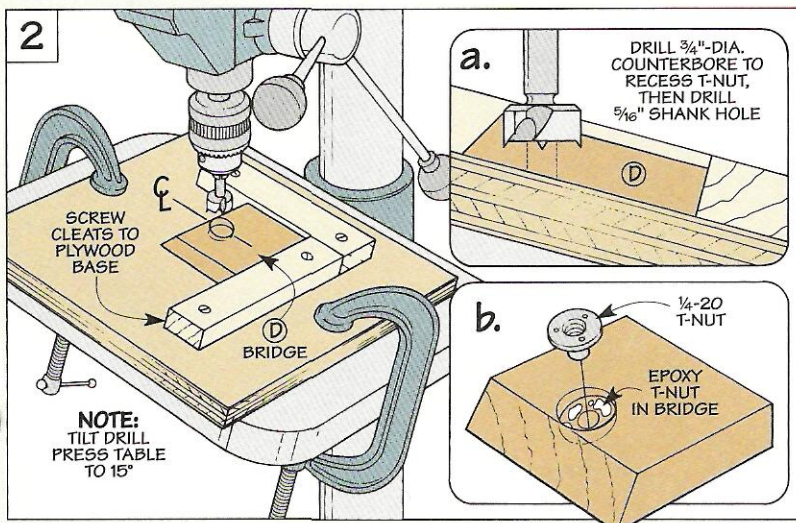

Wedge



The scraper is held tightly in place by a wood wedge that slips down into the opening between the bridge and the scraper.

The *wedge (E)* is made from the remaining part of the blank used to cut the core pieces, see

drawing below. A curved notch in the bottom allows the wedge to slide over the thumbscrew. (I drilled a hole and removed the waste with a hand saw.)

JIG. To hold the wedge safely when cutting the angle on the face, I used a simple jig. It's a scrap of "two by" material with

dowels for handles, see Fig. 3. Fitting the blank between two cleats that are glued in place and screwing it to the jig makes it easy to cut the wedge.

CURVED TOP. Now it's just a matter of cutting the curve at the top with a bandsaw (or sabre saw) and sanding it smooth.

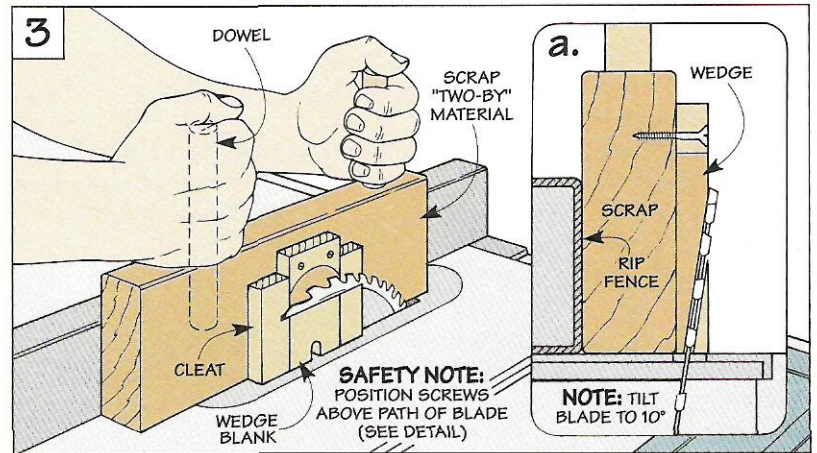
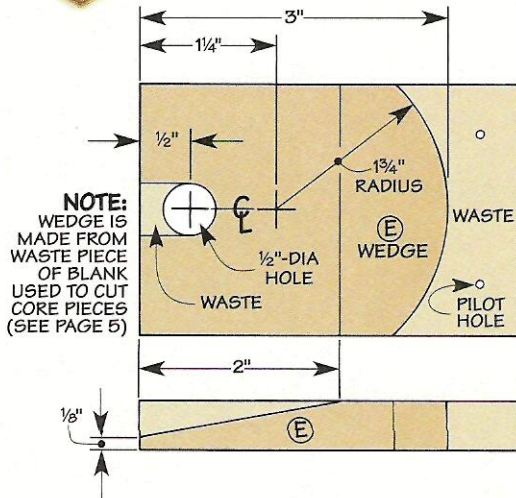

Handles

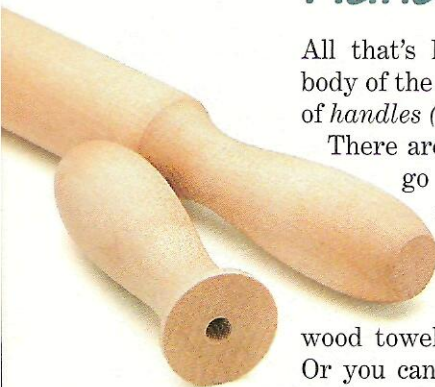

All that's left to complete the body of the plane is to add a pair of *handles (F)*, see drawing.

There are a couple of ways to go about this. One ready-made solution that we used for the maple plane is to cut the handles off a wood towel holder, see margin. Or you can turn the handles to shape on a lathe which is what we did with the walnut plane shown on the back page.

Towel holders with handles already turned to shape are available from:

- Cherry Tree
800-848-4363

STEEL ROD. Either way, the handles are held in place with an ordinary steel rod that I picked up at the local hardware store. To strengthen the handles, the rod passes through both sides and the bridge of the plane, see detail 'a'.

This requires drilling holes for the rod in the ends of each handle

and through the body of the plane, see Figs. 4 and 5. To do this, drill halfway through from both sides using the holes drilled earlier in the sides as guides.

EPOXY. After drilling the holes, simply attach the handles to the rod and the sides of the plane with epoxy.

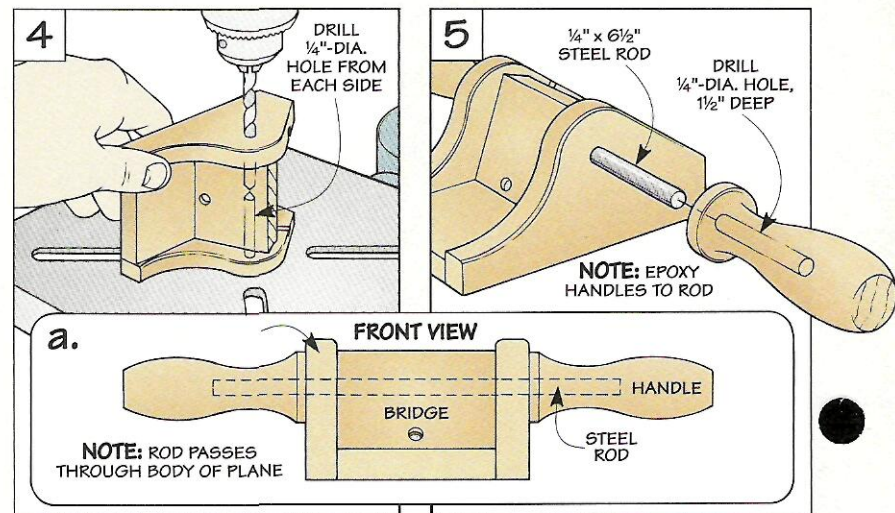
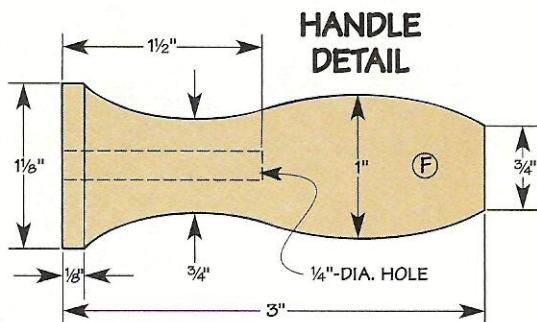

Sole Plates

At this point, all the wood parts of the plane are complete. But to protect the bottom of the plane from wear, I added two brass sole plates, see drawing.

These are 2"-wide strips that are attached to the front and back base pieces. (Brass strips are available at many hobby shops.)

The strips are held in place with small brass screws. Note: To avoid splitting the wood, the holes for the screws in the back plate are located *farther* from the inside edge, see detail 'a'.

COUNTERSINKS. To keep from gouging the workpiece, the screws are countersunk in the sole plates. What works well here is to tighten a countersink bit in

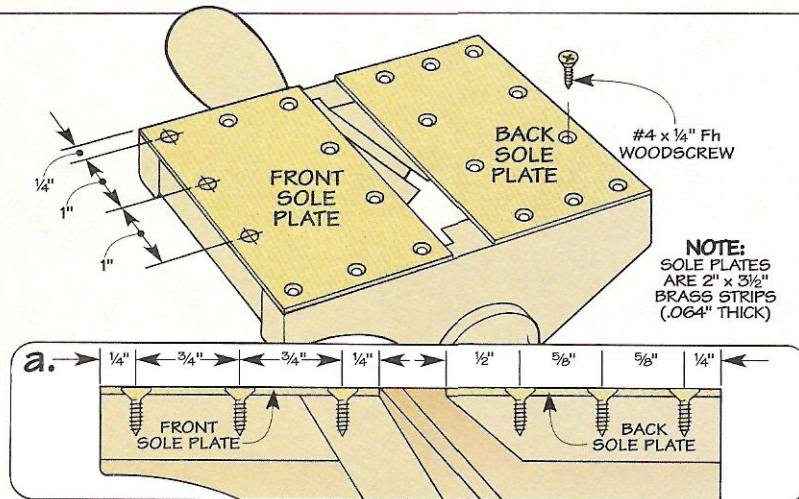

the drill press and turn the chuck by hand, see photo A at right.

FITTING. After screwing the sole plates in place, it's just a matter of filing and sanding the edges

flush with the plane, see photo B.

Finally, I sanded the sole flat using silicon-carbide sandpaper (up to 600 grit), see photo C. A piece of glass ensures a flat surface.

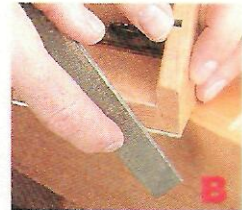

Setup

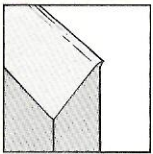

The scraper plane is easy to set up. But first you'll need to sharpen the scraper.

SHARPENING. What you're after is to create a "hook" or burr that scrapes the wood fibers, see drawing above. Start by filing the end of the scraper at about a 45° angle (the exact angle isn't critical). Then roll the edge with a burnisher or hardened piece of steel (like a drill bit) to form the burr.

SETUP. Once the scraper is sharpened, you can set up the plane. The quickest way I found to do this is to place the plane on a flat surface.

Then just slip the scraper into the plane so the burr faces toward the *back*, see Step 1 below. And when the scraper "bottoms out," slide the wedge into place, see Step 2.

All that's left now is to flex the scraper in a slight bow by adjusting the finger screw, see Step 3.



A half turn or so after it contacts the scraper is just about right.

The best way to check is by making a trial cut. Pushing the plane across a board at an angle should produce thin, lacy shavings, see the photo above.

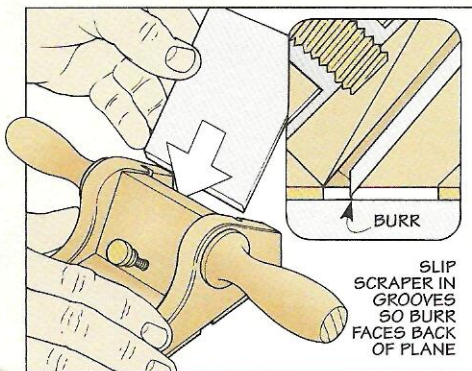

Step 1. With the plane resting on a flat surface, back off the finger screw and slip the scraper in until it bottoms out.

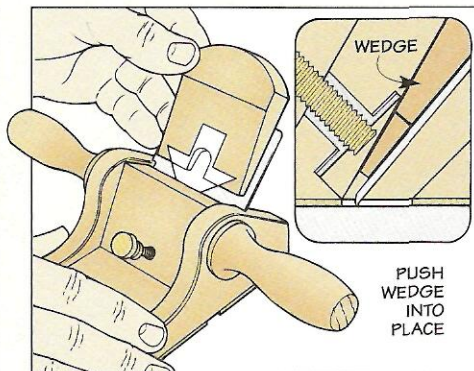

Step 2. Now slide the wedge down until it's firmly seated between the bridge and the scraper blade.

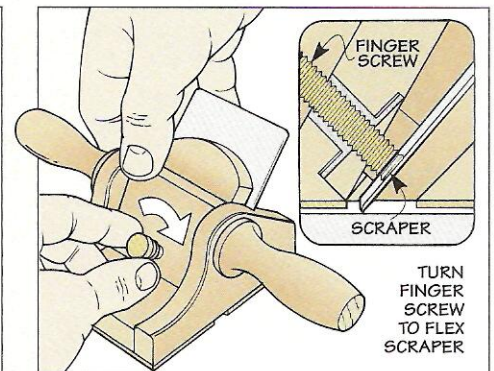

Step 3. Turning the finger screw flexes the scraper in a slight bow which helps produce fine, wispy shavings.

Splined Mitters

How do you add strength to a miter joint? Rout a groove and glue in a wood spline.

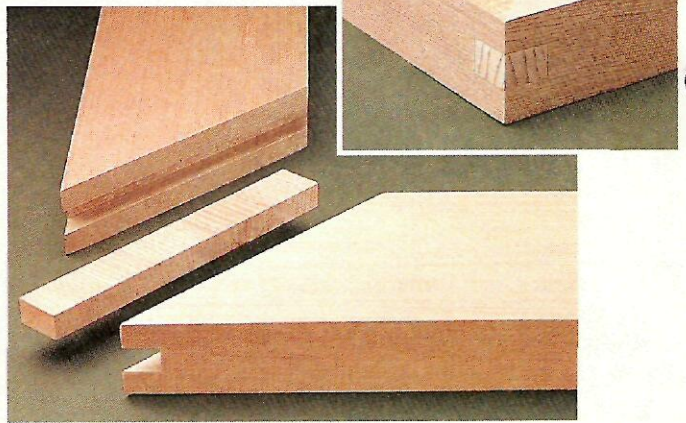

I've always thought of a miter joint as something of a mixed bag. Since the pieces are joined together at an angle, the end grain is hidden. But gluing end grain to end grain produces a weak joint.

SPLINE. Fortunately, all that's needed to strengthen a miter joint is a simple spline. This is just a strip of wood that's glued into a groove cut in the angled end of each piece, see photos above. With a spline, you get a larger glue surface. And it creates a strong surface-to-surface glue joint.

SLOT CUTTER. A quick way to cut the grooves for the splines is to use a router and a slot cutter bit, see margin at left. Depending

on the length of the pieces, I use two different approaches.

LONG PIECES. Since long pieces can be awkward to handle (like the pieces in the picnic table on page 10), it's easiest to clamp them to the bench and use the router in a hand-held position.

The problem is the tip of the miter doesn't provide much support for the router base. And when the bit cuts through, it's likely to chip out the edge of the workpiece. To support the base and prevent chipout, I clamp mitered scraps on each side of the workpiece, see Fig. 1.

GROOVE. Now it's just a matter of routing the groove. As a rule, the width of the groove is

about a third the thickness of the workpiece. (Rout a $\frac{1}{2}$ "-wide groove in $1\frac{1}{2}$ "-thick stock for example.) And the depth of the groove matches its width.

To ensure the groove is centered on the thickness of the workpiece, the idea is to rout it in two passes — flipping the workpiece between each one. (I use a slot cutter that's smaller than the width of the groove.)

The thing to be aware of here is if you rout the upper part of the groove first, there won't be any material left to guide the bearing during the second pass. So you'll need to rout the lower part first, see Fig. 1. Then flip the workpiece over, reposition the scraps, and rout the upper part, see Fig. 2.



A slot cutter bit makes quick work of routing a groove for a spline. And different size bearings let you adjust the depth of cut.

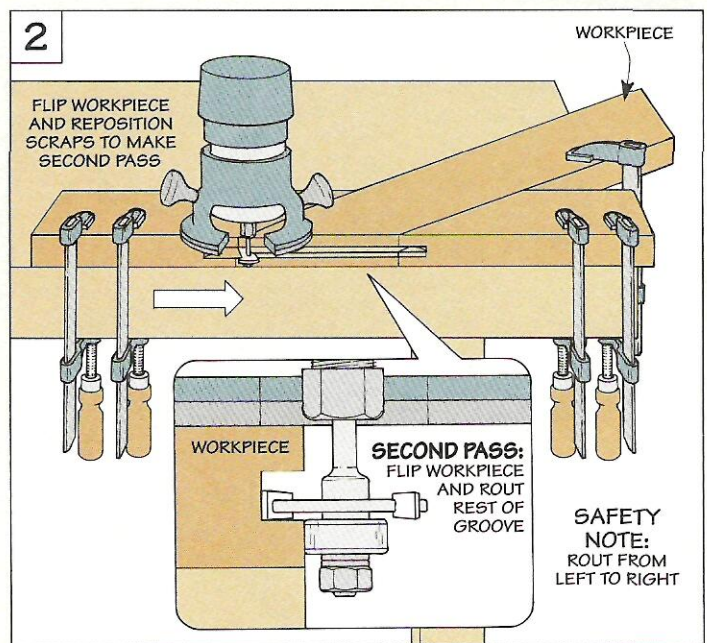
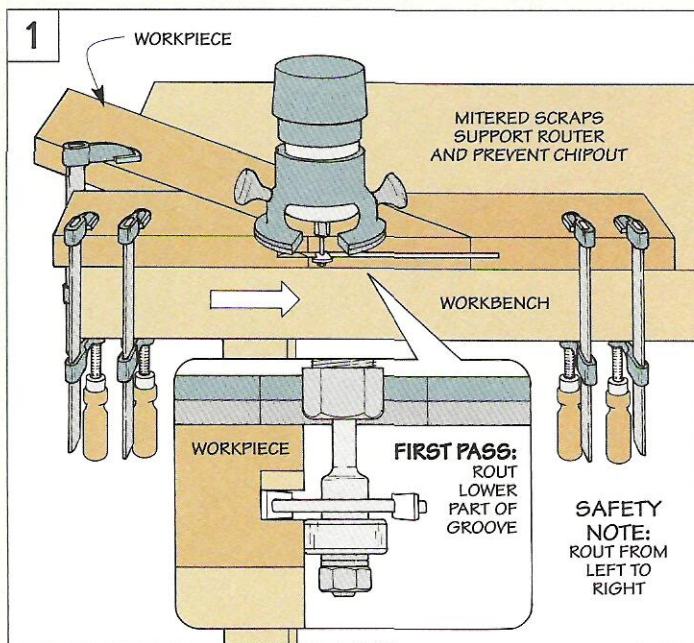

and rout the rest of the groove, see Fig. 2.

SHORT PIECES. When routing a groove in a short workpiece, I find it's quicker and easier to use

the router table.

The basic idea is the same. The groove is routed in two passes, see Figs. 3 and 4. And using a mitered scrap as a push block re-

duces chipout. To prevent the tip of the miter from catching, I carpet-tape a piece of Masonite to close the opening in the fence, see margin tip at right.

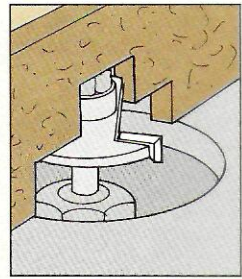

A piece of Masonite with notches cut in it prevents the tip of the miter from catching on the opening in the fence.

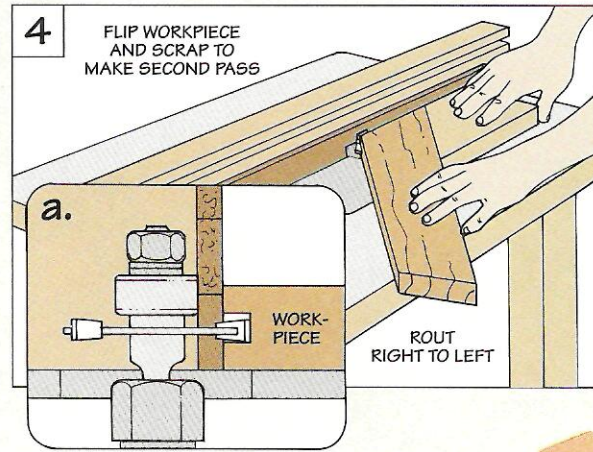
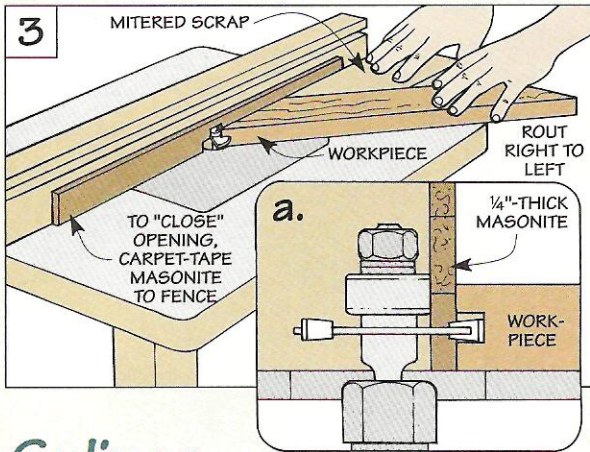

Splines

Once you've routed the grooves, the next step is to cut the splines.

GRAIN. The important thing here is the direction of the grain in the spline. To provide the most strength, the grain should run perpendicular to the joint line,

see photo on previous page.

SIZE. Besides the grain direction, you also need to consider the size of the spline.

What you want is to cut the spline to thickness so it fits snug in the groove. But not so tight

that it squeezes out all the glue.

And to ensure the workpieces draw tightly together, it's cut to length (width) so it doesn't "bottom out" in the grooves.

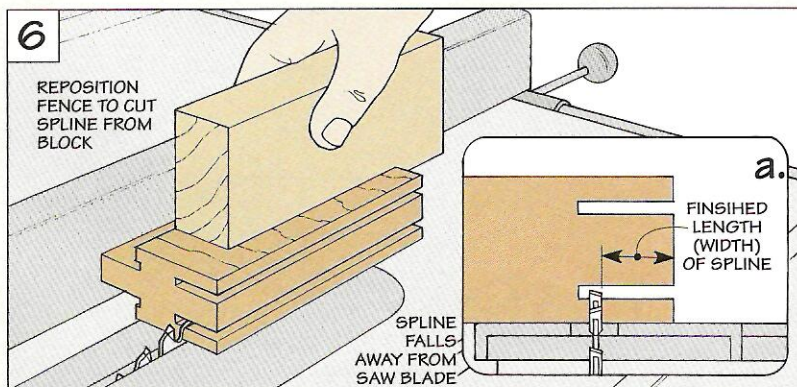
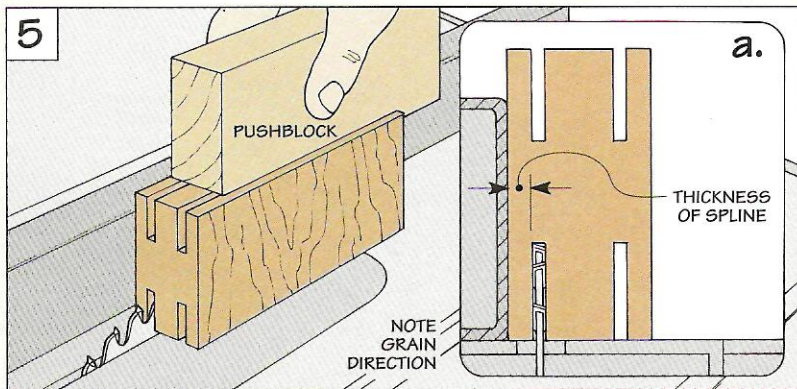
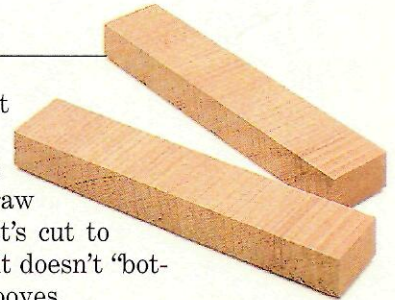

Finally, to allow for trimming, I usually cut the spline from a block of wood that's wider than the length of the joint. Note: When working with wide pieces like those on the picnic table, you can butt two small splines together.

CUT SPLINES. An easy way to make the splines is to use a scrap from the project you're working on and cut it on the table saw. Start by setting the rip fence to the desired thickness of the spline, see Fig. 5.

Then raise the blade $\frac{1}{8}$ " higher than the length (width) of the spline and cut a series of kerfs. After repositioning the fence and lowering the blade so it just cuts into the kerf, you can cut each spline from the block, see Fig. 6.

ASSEMBLY. Now it's just a matter of applying glue to the splines and grooves and clamping the pieces together. When the glue dries, trim the end of each spline flush and sand it smooth. 

Picnic Table

As sturdy as it is good looking, this picnic table is built to last.



All it took was a few warm days to remind me of the picnic table and benches I'd been planning to build. What I had in mind was a simple, straightforward design. Something I could knock out in a few days, yet sturdy enough to last for years.

To make the table and benches easy to build, the joinery on each one is identical. Strong mortise and tenon joints keep the bases from racking. And splined miters ensure that the tops stay flat.

But no matter how strong the

joints are, the table and benches still need protection from the weather. So I used redwood for the tabletop and benchtops and applied an outdoor oil. And I built the bases with less expensive Douglas fir and applied several coats of paint. (For more on redwood and outdoor finishes, see pages 30 and 31.)

needed with stretchers at the top and bottom, see drawing below. And a pair of supports for the top span the upper stretchers.

END ASSEMBLIES. Each end assembly is made up of a pair of legs held together with a rail at the top and bottom, see Fig. 1.

To simplify the mortise and tenon joinery, each leg is built up from two *leg pieces* (A). Cutting a dado near the middle and a rabbet at the top of each piece will form "mortises" for the rails when

TABLE BASE

I started work by building the base of the table. It consists of two end assemblies that are con-

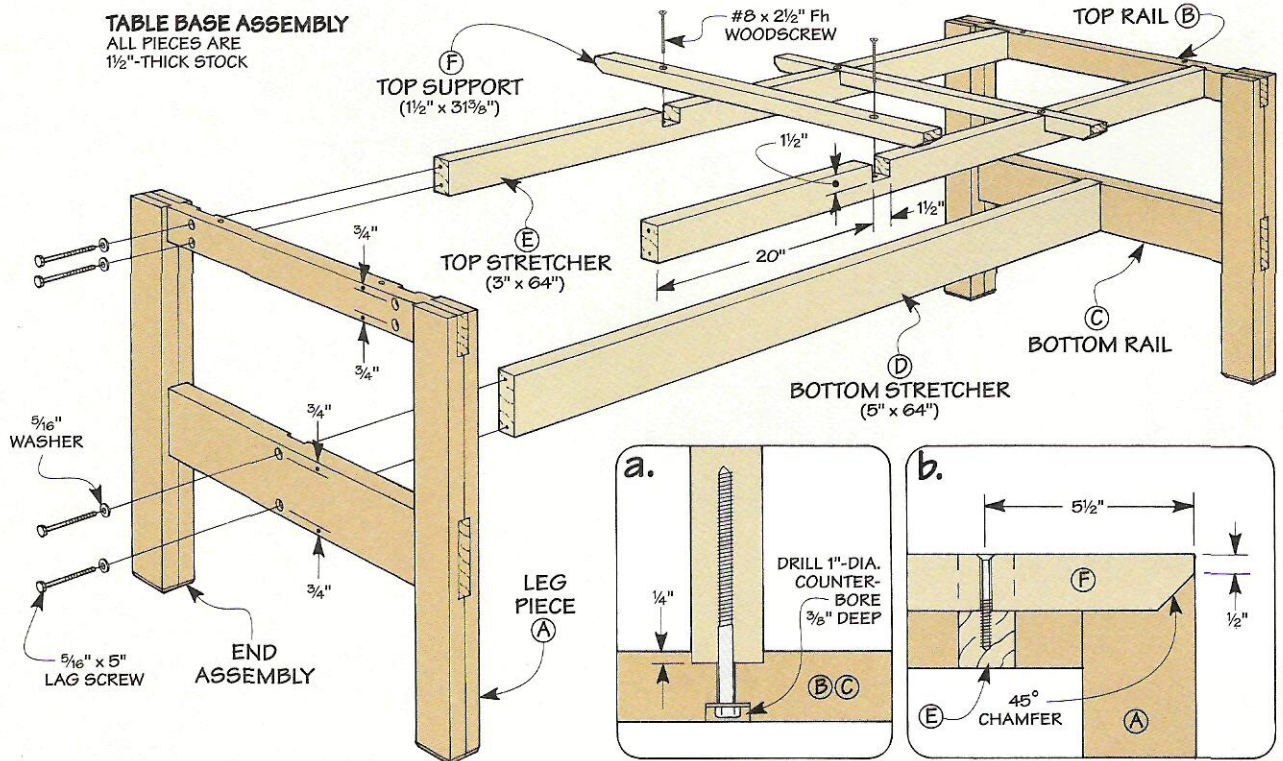

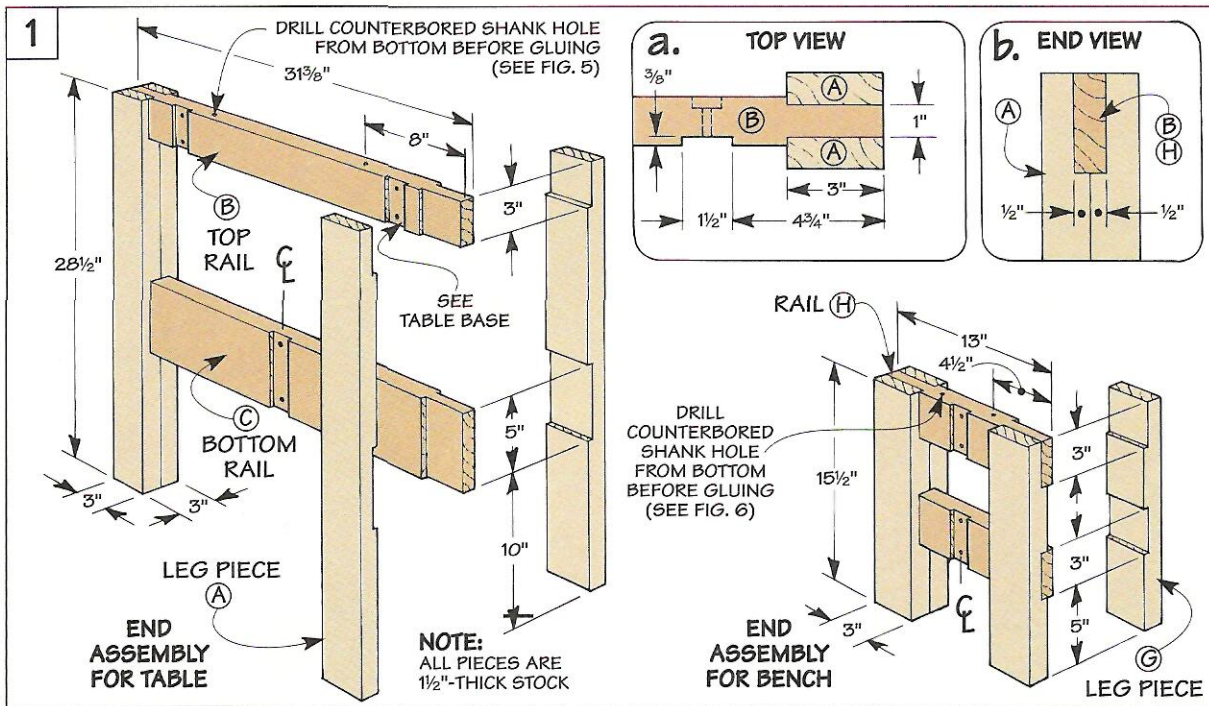

the legs are glued up.

RAILS. Each leg is held together with a narrow *top rail* (B) and a wide *bottom rail* (C). Tenons are cut on the end of each rail to fit the mortises, see Figs. 1a and 1b. And to accept the stretchers, there are two shallow dados in the top rail and a single dado centered on the bottom rail.

To make assembly easier, two counterbored shank holes are drilled on each dado, see detail 'a' on page 10. And counterbored shank holes drilled from the bottom of the rails will be used to attach the top, see Figs. 1 and 5.

Now it's just a matter of gluing up each end assembly. To provide plenty of working time (and protect against moisture), I used slow-curing epoxy.

STRETCHERS. To hold the end assemblies together, I added a *bottom* (D) and two *top stretchers* (E). After cutting a pair of notches in each top stretcher to accept the supports (added next), the stretchers can be attached to the end assemblies with lag screws.

TOP SUPPORTS. All that's left to complete the base is to add

two *top supports* (F). To provide some extra knee room when sitting down to a meal, the ends of these supports are chamfered, see detail 'b' on page 10. Then the supports are simply screwed in place so the ends are flush with the leg assemblies.

BENCH BASE

The bases for the two benches are built the same way as the table base. But the size and number of

parts is just a bit different.

The biggest difference is the *leg pieces* (G) are shorter, see Fig. 1. And unlike the table base, the *rails* (H) that join the legs together are both the same width.

Another difference is the end assemblies are held together with two *stretchers* (I) instead of three, see drawing below. And both stretchers are the same width. Here again, two notches accept the *top supports* (J).

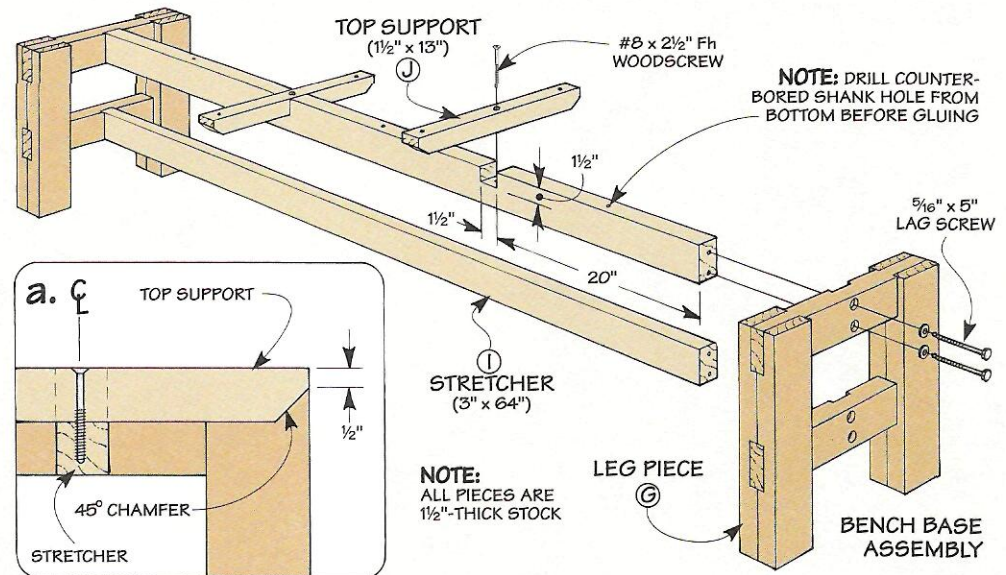

Tabletop

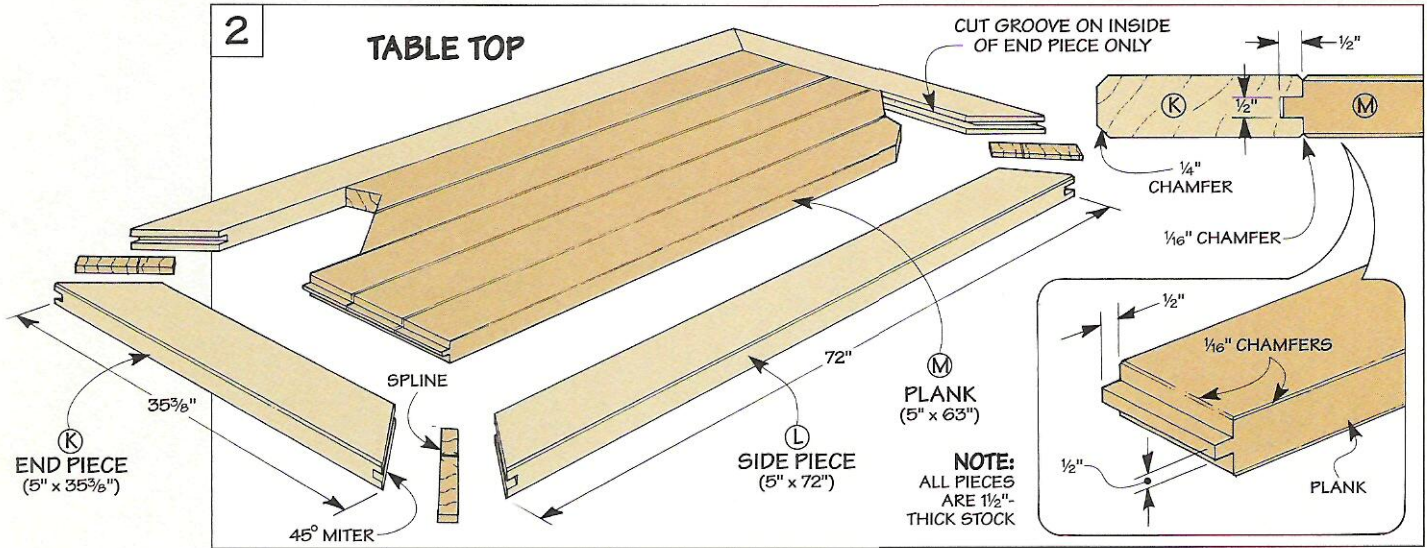

With the bases complete, you can turn your attention to the tabletop. It consists of a mitered frame that surrounds several wood planks, see Fig. 2.

FRAME. The frame is made up of two *end (K)* and two *side pieces (L)* that are mitered at a 45° angle, see Fig. 2. To strengthen the miter joints, they're held together with wood splines. These splines fit in grooves that are routed in the end of each frame piece. (For more on making splined miters, refer to the article on page 8.)

In addition to the grooves for the splines, you'll need to rout two other grooves of the same size. To accept the tongues on the

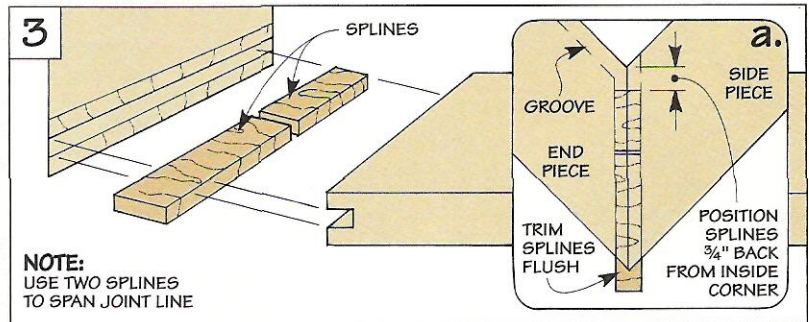

planks that are cut next, there's a groove in the *inside* edge of each end piece, see Fig. 2.

PLANKS. With the frame complete, the next step is to cut the *planks (M)* to length, see Fig. 2. Rabbeting the end of each plank on the top and bottom forms a tongue that fits the grooves in the

end pieces, see Fig. 2a.

CHAMFER. While I was at it, I routed a decorative chamfer ($1/16$ ") around the top and bottom edges of the planks and the *inside* edges of the frame pieces.

SPLINES. Before assembling the tabletop, you'll need to make the splines. I found it easiest to

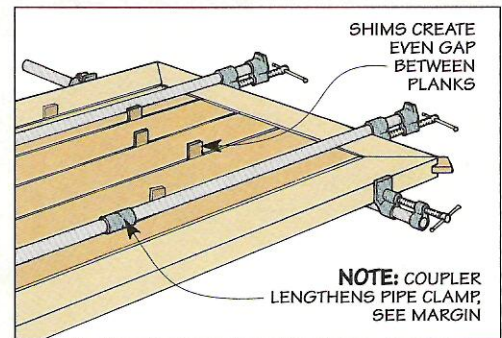
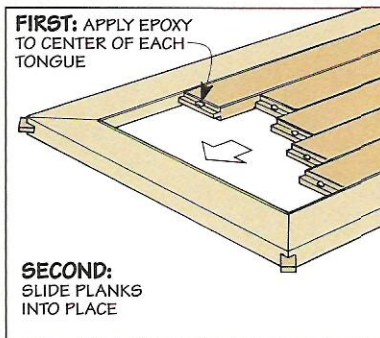
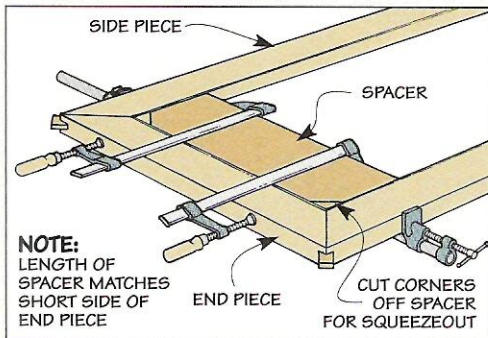

Assembly. The first step is to epoxy two corners of the frame. Clamping a spacer to the end of the frame and positioning another clamp across the sides keeps the corners square, see drawing at left. Then apply epoxy to the

center of each tongue and slide the planks into the end of the frame, see middle drawing. Finally, with shims creating an even gap between the planks, clamp the opposite end of the frame in place, see margin and drawing at right.

use the cutoffs from the top for this. But since these pieces are too narrow to span the length of the joint line, you'll need to butt two small splines together, see Fig. 3.

ASSEMBLY. Now you're ready to assemble the tabletop. Even after dry assembling and checking the fit, gluing up a large project like this can be a challenge. So I assembled it in stages, see bottom of page 12.

There are a couple of things to watch for here. To avoid filling the grooves that the planks fit into, the splines are set back from the inside corner, see Fig. 3a. And to allow for wood movement, I used shims to create a uniform ($\frac{1}{16}$ " gap between the planks and applied epoxy to the center of each tongue only.

After trimming the splines

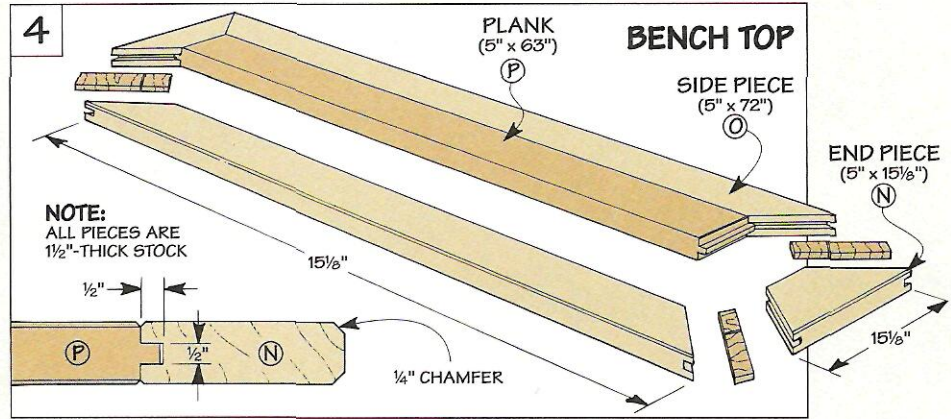

flush, there's just one more thing to do. That's to "break" the sharp edges on the top and bottom of the table by routing a $\frac{1}{4}$ " chamfer.

BENCHTOPS

The two tops for the benches are built the same way as the tabletop. They're just smaller.

While the *end pieces* (N) on the

benchtops are quite a bit shorter than the ones on the tabletop, the *side pieces* (O) are exactly the same length, see Fig. 4.

Here again, the mitered frame for each benchtop is held together with splines. And a tongue on the end of a single *plank* (P) fits into a groove in each end piece.

Assembly

At this point, all that's left is to attach the top of the table and the benchtops to their bases.

TABLE. The easiest way to position the tabletop is to place it upside down on the floor and center the base on top of it, see Fig. 5.

After drilling counterbored shank holes in the stretchers (E) and countersunk shank holes in the top supports (F), the top is simply screwed in place, see details in Fig. 5. Installing screws in the holes drilled earlier in the top rails (B) secures the ends of the frame.

BENCHES. Now it's just a matter of attaching the two benchtops. They're screwed to the bases using the same basic procedure as before, see Fig. 6.

CHAMFER. There's one last thing to do. To prevent the legs from splintering when moving the table and benches, I sanded a slight chamfer on the bottom edges, see Figs. 5 and 6.

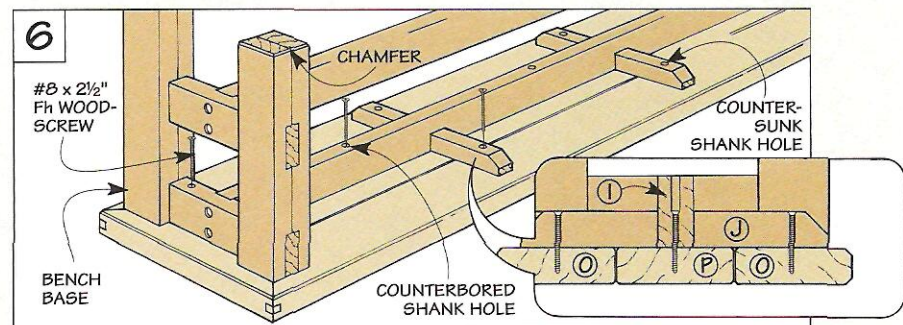
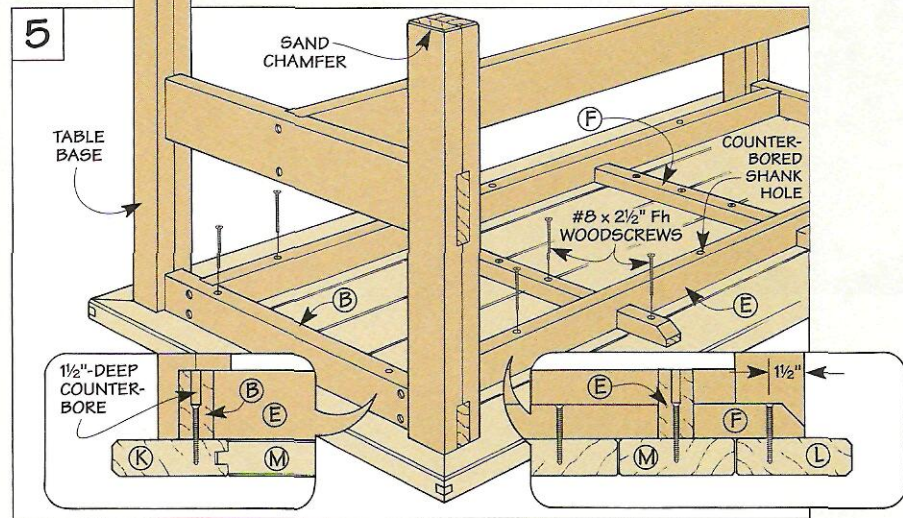

Great Plywood Tips

Here's a collection of tips that are sure to come in handy the next time you're working with plywood.

Cutting Guide

■ Clamping a board to plywood guides the base of a circular saw or router so you can make a straight cut. But positioning it on the workpiece so the cut is made

exactly where you want can be a guessing game. To solve this, I use a cutting guide, see photos.

The way it works is simple. The edges of the guide act as a refer-

ence that indicates the path of the blade (or bit). So to ensure an accurate cut, just align one of the edges of the guide with the layout lines on the workpiece.

There's nothing complicated about making the cutting guide. Start out with an extra-wide base made from 1/4"-thick hardboard, see drawing. After gluing and screwing a plywood fence to the base, one reference edge is created by trimming off the waste with a circular saw. And the other by cutting it off with a straight bit in a router.

To use the guide, clamp it to a workpiece so the edge aligns with the layout marks. Then just make a cut with the same blade or bit that you used to create the reference edge. Note: Since a router bit may not be exactly centered in the base of the router, keep the same point on the base against the fence.

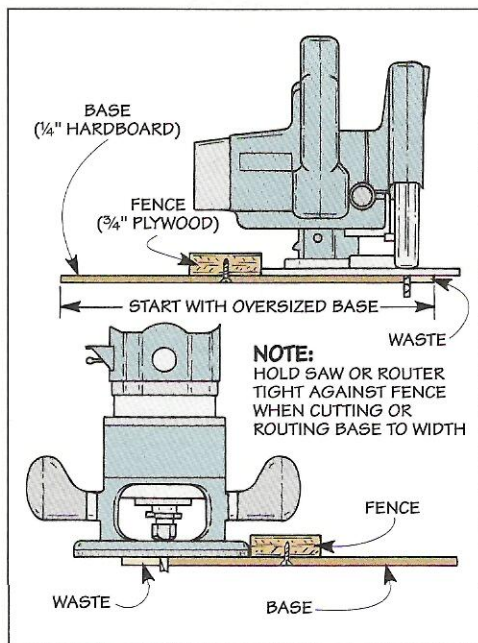

Quick Tips

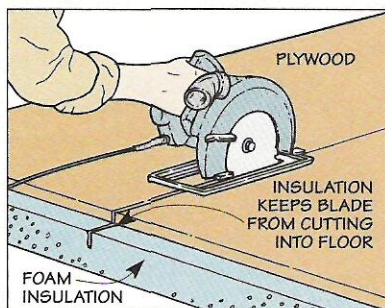

▲ Laying a sheet of foam insulation on the floor makes it easy to cut a full sheet of plywood down to manageable size.

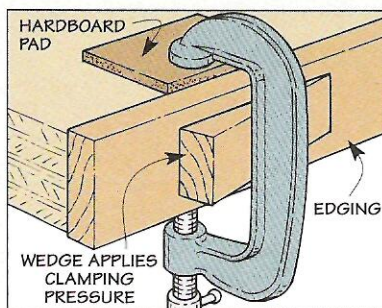

▲ To glue edging strips to plywood, simply position C-clamps along the edge and use a wedge to apply pressure.

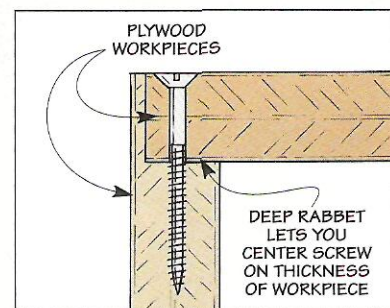

▲ By cutting an extra deep rabbet, you can center a screw on the thickness of the workpiece. This way, it won't split out the side.

Reducing Chipout

■ Few things are more frustrating than having a saw blade chip out the face veneer on an expensive piece of plywood.

While a blade that's specially designed to cut plywood can prevent this (see box at right), you can also get good results with a combination saw blade.

SCORE. One way is to use the saw blade to lightly score the plywood, see Fig. 1. To do this, raise the saw blade so it just barely cuts through the face veneer and make a pass.

This way, the blade severs the wood fibers of the veneer instead

of tearing them out. A second full-depth pass completes the cut and produces a crisp edge.

INSERT. Another way to get a quality cut is to replace the original metal insert on the table saw with a zero-clearance insert made of wood, see Fig. 2.

The basic idea here is to eliminate the opening between the blade and the insert by providing support right up next to the saw blade. This way, when the blade cuts through the workpiece, the insert backs up the bottom face of the plywood and prevents the veneer from splintering.

One way to improve the quality of cut when working with plywood is to use a saw blade that's designed just for that purpose.

To produce razor sharp cuts, both the 10" table saw blade and 7¼" circular saw blade shown here have 200 small steel teeth set around the perimeter of a thin, tapered rim. A thick, center hub adds rigidity to the blade.

Note: To avoid binding, adjust the blade height so only the rim (not the hub) passes through the workpiece.

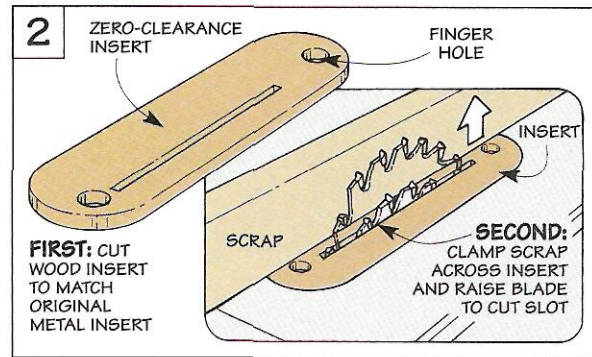
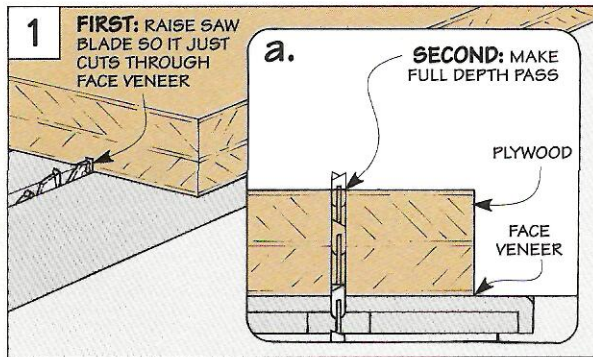
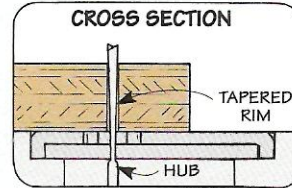

Flush Trimming

■ To create the look of a solid wood panel, the lip on a piece of edging that stands a bit proud needs to be trimmed flush with the surface of the plywood.

PLANE. If there are only a few pieces, I use a block plane to remove most of the waste. To avoid

gouging the plywood, apply a piece of masking tape and plane until the tape starts to "fuzz," see Fig. 1. With the tape removed, you can finish up with a sanding block. Just sand until pencil marks on the plywood start to disappear, see detail.

ROUTER. A router and a flush trim bit make quick work of the job if you have a lot of pieces to trim, see Fig. 2. Clamping a scrap to the workpiece keeps the router from tipping. And a rabbet in the scrap provides clearance for the lip on the edging, see detail.

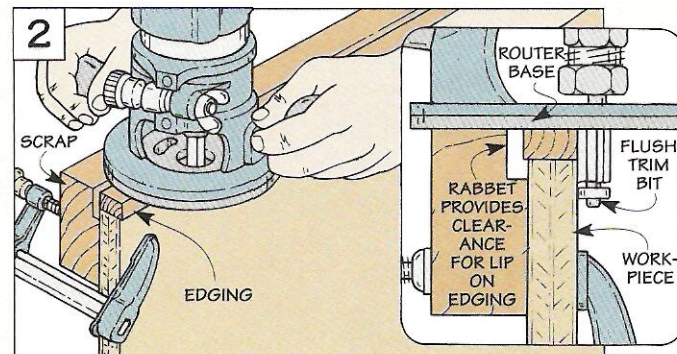
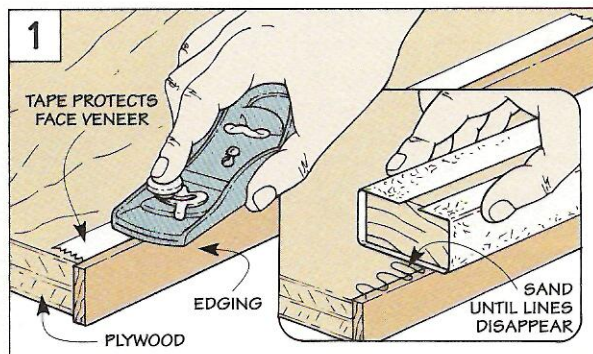

Sliding Cutoff Table

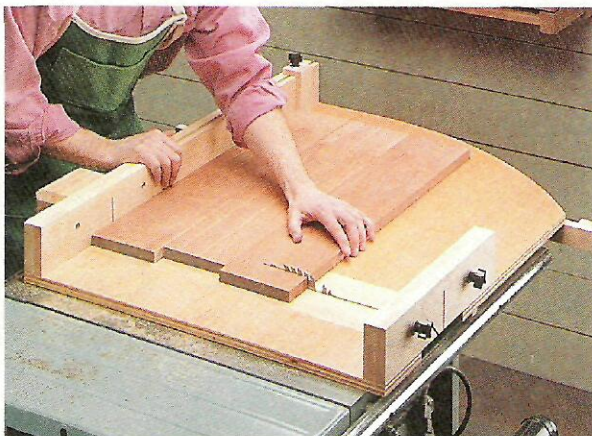

Wide Panels. To make accurate crosscuts on panels up to 24" wide, this sliding cutoff table combines a large plywood platform with a long fixed fence.

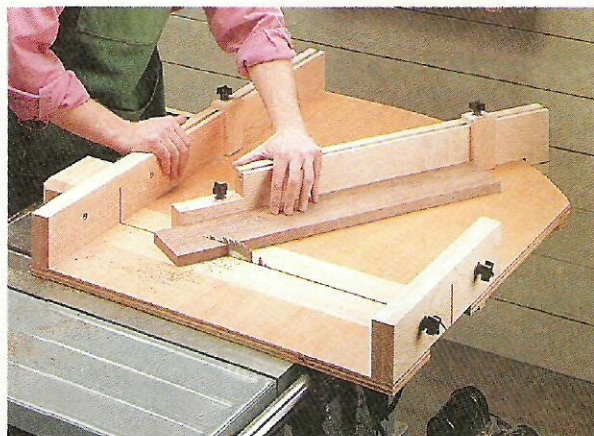

Angled Cuts. By attaching an adjustable fence that pivots around the curved end of the sliding table, you can make angled cuts as well.

I can't tell you where it is exactly. But there's a point of no return for the miter gauge on my table saw. Especially when I pull it back to crosscut a wide panel.

It's the point where the head starts to wobble because the runner isn't fully supported in the miter gauge slot. And that makes it almost impossible to crosscut a wide panel safely and accurately.

That's why I built this sliding cutoff table. With the workpiece resting on a large platform that slides across the saw table, it's

easy to crosscut panels up to 24" wide, see top left photo. And adding an adjustable fence allows you to make angled cuts as well, see top right photo.

STOP BLOCKS. Whether you make straight or angled cuts, sometimes you need a number of pieces that are identical in length. To ensure accuracy, a pair of stop blocks that slide in T-shaped slots in the fences can be locked tightly in place, see photo A.

INSERTS. In addition to the stop blocks, this sliding cutoff ta-

ble has two "zero-clearance" inserts that prevent chipout on the bottom of a workpiece. To make this work for both 90° and 45° cuts, it's just a matter of removing one insert and replacing it with another, see photo B.

SAFETY. Finally, a pair of wood blocks work together to stop the table at the end of a cut. This "buries" the blade in a thick wood block on the back of the table, see photo C.

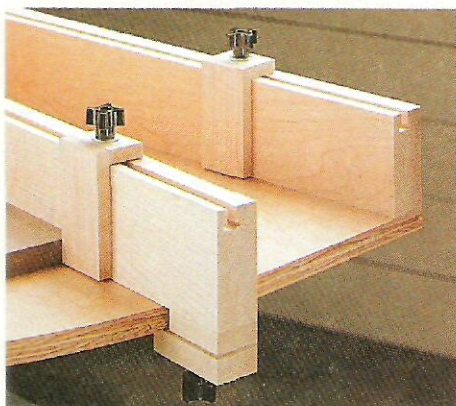

A. Stop Blocks. A pair of stop blocks allows you to cut multiple pieces to length quickly and accurately.

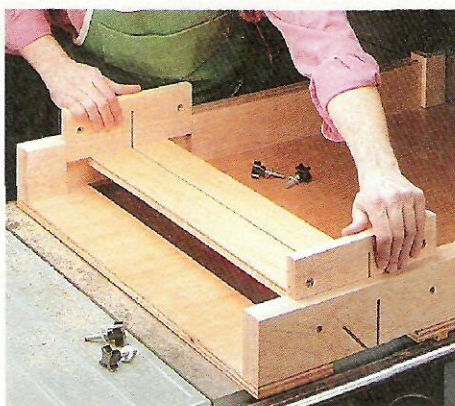

B. Inserts. Two removeable inserts (one for 90° and the other for 45° cuts) reduce chipout on the bottom of a workpiece.

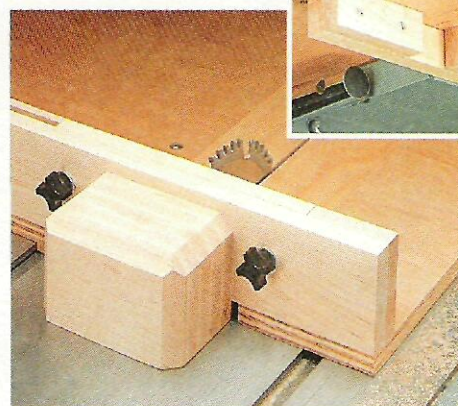

C. Safety System. A thick wood block and two stops prevent the blade from being exposed at the end of a cut.

FEATURE PROJECT

EXPLODED VIEW
OVERALL DIMENSIONS:
6"H x 40½"W x 32¼"D

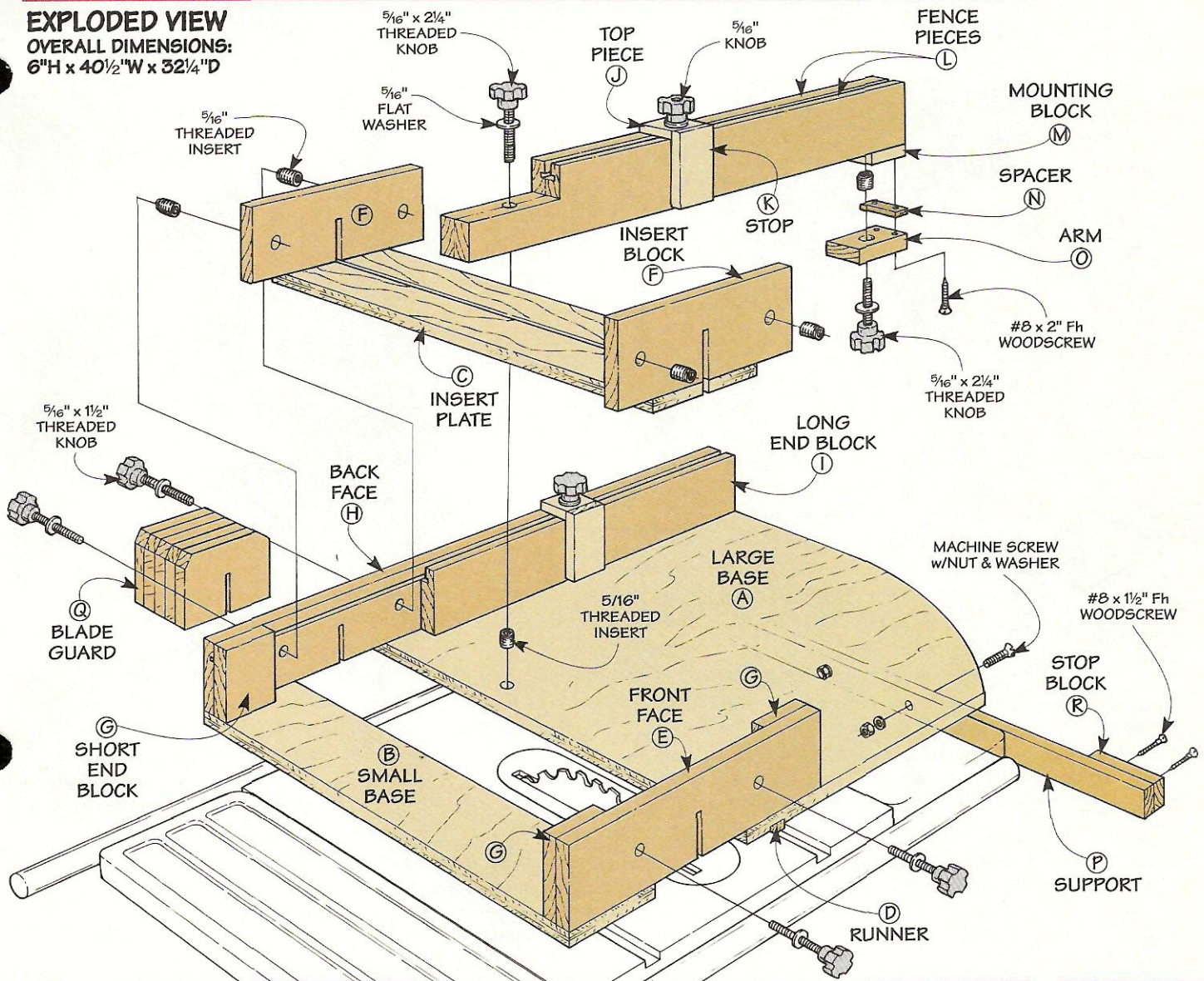

Materials

A Large Base (1)	27½ x 27 - ¾ Ply.
B Small Base (1)	27½ x 5 - ¾ Ply.
C Insert Plates (2)	6 x 26 - ¾ Ply.
D Runner (1)	½ x ¾ - 27½
E Front Face (1)	¾ x 3½ - 16
F Insert Blocks (4)	¾ x 3½ - 10
G Short End Blocks (3)	¾ x 3½ - 3
H Back Face (1)	¾ x 3½ - 38
I Long End Block (1)	¾ x 3½ - 25
J Top Pieces (2)	½ x 2 - 1¼
K Stops (2)	½ x 2 - 3⅞
L Fence Pieces (2)	¾ x 3½ - 32
M Mounting Block (1)	⅝ x ½ - 2¼
N Spacer (1)	½ x ¾ - ⅛ Mas.
O Arm (1)	¾ x 1½ - 3
P Support (1)	¾ x 1½ - 39
Q Blade Guard (5)	¾ x 3¾ - 5½
R Stop Blocks (2)	¾ x 1½ - 4

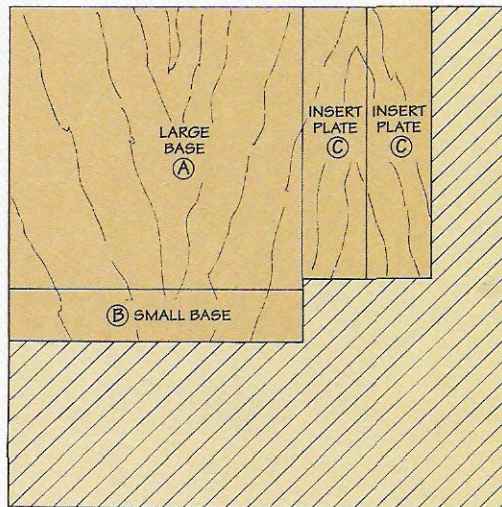

48" x 48" - ¾"-THICK PLYWOOD

Hardware

- (10) 5/16" Threaded Inserts
- (2) 5/16" x 1¾" Toilet Bolts
- (2) 5/16" x 2¼" Threaded Knobs
- (4) 5/16" x 1½" Threaded Knobs
- (2) 5/16" Plastic Knobs
- (8) 5/16" Washers
- (23) #8 x 1½" Fh Woodscrews
- (4) #8 x 2" Fh Woodscrews
- (4) #8 x ¾" Fh Woodscrews

To order a complete hardware kit, call:
 800-347-5105
 6827-200.....\$12.95

Base

To build accuracy into the sliding table, check that the corner of the large base piece is square, and the miter gauge slot is parallel to the blade.

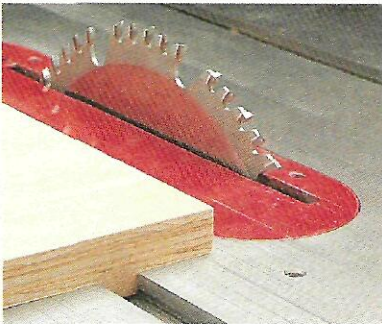

I began work on the cutoff table by building a plywood base. It serves as a platform that carries the workpiece through the blade.

The base is made up of three parts: a *large* (A) and *small* base (B) piece with a removeable *insert plate* (C) sandwiched in between, see Fig. 1. Note: To make straight and beveled cuts, I made two insert plates.

CURVE. To keep the adjustable fence (added later on) from binding, there's a curve cut on the outside corner of the large base piece, see Fig. 2. This requires establishing a pivot point for the fence, then cutting the curved shape and sanding it smooth.

RUNNER. The base is guided by a hardwood runner that slides

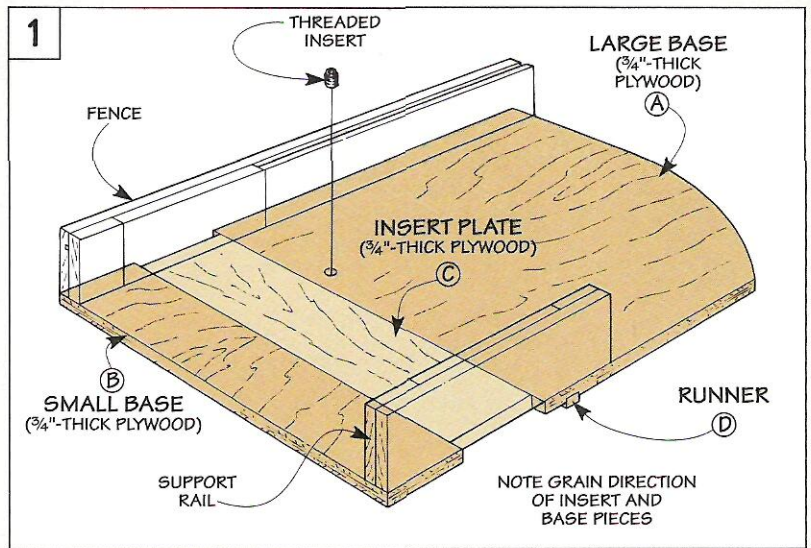

in the miter gauge slot. To produce accurate cuts you'll need to make sure this slot is parallel to the blade.

The runner fits in a dado cut in the bottom of the base. When laying out the location of this dado, the idea is to have the blade cut through the *center* of the insert. To do this, place the base piece on the saw table 3" away (half the width of the insert) from the center of the blade, see Fig. 2a. Then mark the location of the dado by

using the slot as a reference.

Before cutting the dado, it's best to have the *runner* (D) in hand. It's a piece of hardwood (maple) cut to fit the miter gauge slot so it slides smoothly without any "play", see Fig. 2b.

THREADED INSERT. After cutting the dado and screwing the runner in place, all that's left is to install a threaded insert, see Fig. 3 and margin at left. It fits in a hole that's drilled at the pivot point for the adjustable fence.

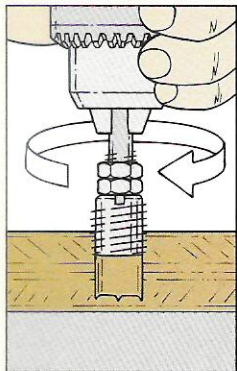

To install a threaded insert, chuck a cutoff bolt with two nuts tightened against each other in the drill press. Then turn the chuck by hand.

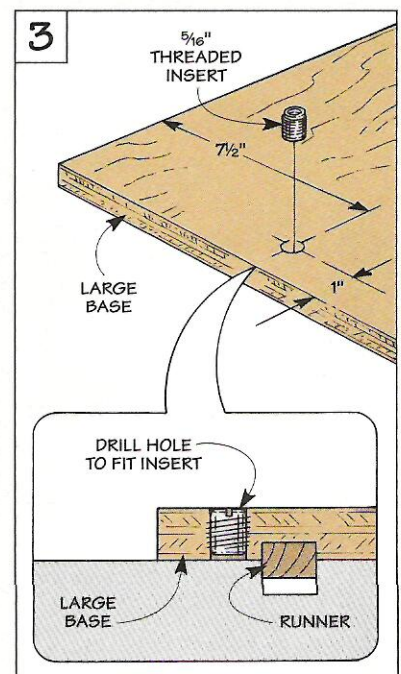
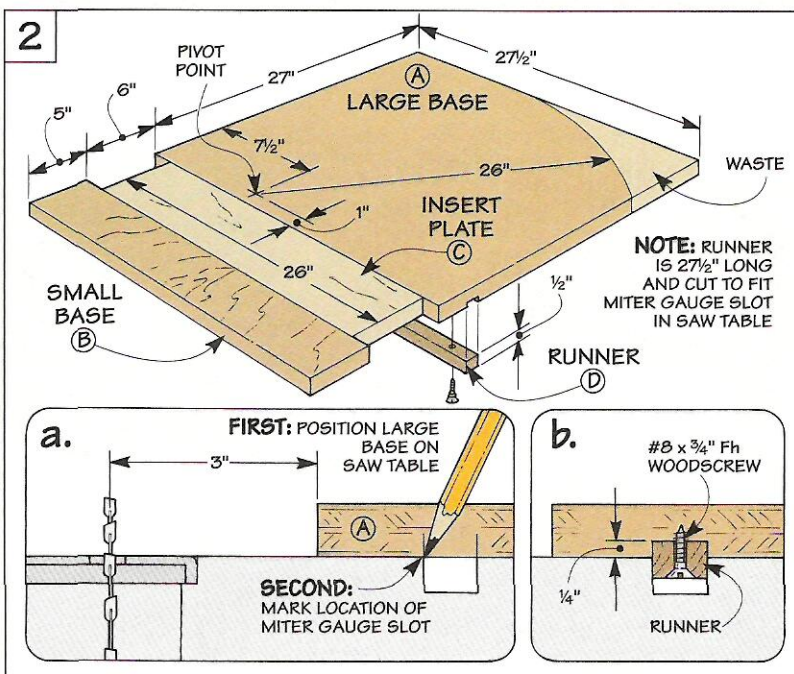

Fixed Fence & Support Rail

The base is held together with two parts. A fixed fence runs across the back edge and supports the workpiece as you make a cut, see Fig. 4. And a support rail adds rigidity to the front.

POCKET. To slip the inserts in and out of the sliding table, the fence and support rail each have a "pocket" that's built up from 3/4"-thick hardwood blocks (maple).

To form this pocket in the support rail, a *front face (E)* is cut to length, see Fig. 5. Then an *insert block (F)* is sandwiched between two *short end blocks (G)*.

Except for its size, the fence isn't all that different. But here, there's a long *back face (H)*. And another insert block (F) fits between the short end block (G) and a *long end block (I)*.

T-SLOT. Before assembling all these pieces, a T-shaped slot is cut in the fence for a toilet bolt (added later). Making this slot is simple. First, cut a shallow groove in the back face (H) and a deeper groove in the long end block (I), see Fig. 5a. Then rabbet the top edge of the long end block.

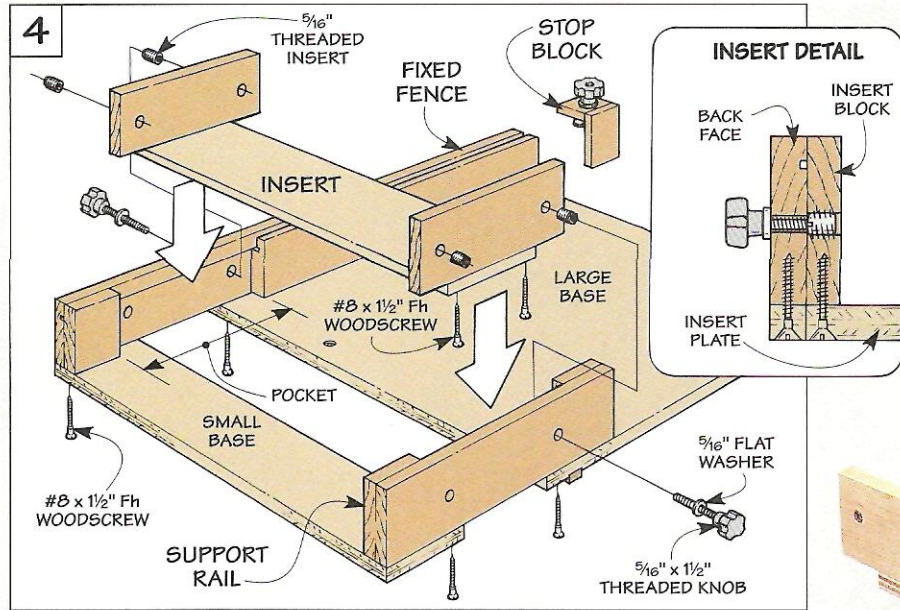

ASSEMBLY. To assemble the fence and support rail, the end blocks *only* are glued in place. (I used the insert blocks as spacers.)

When the glue dries, the fence is screwed (not glued) to the base and flush with the back edge. And the support rail is screwed flush with the front edge.

INSERTS. At this point, the insert plates (B) and insert blocks

(F) can be screwed together to form the inserts, see margin. They're held in place with knobs that tighten into threaded inserts, see Figs. 4 and 5.

STOP BLOCK. All that's left is to add a stop block. It consists of a *top piece (J)* and *stop (K)* glued up in an L-shape, see Fig. 6. Tightening a knob on a toilet bolt that passes through the top piece holds the stop block in place.



With two inserts, you can use one for 90° cuts (top) and the other for 45° cuts (bottom).

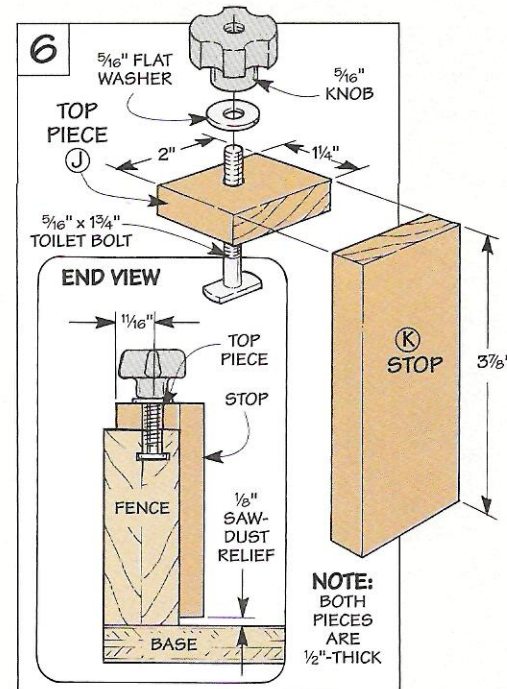
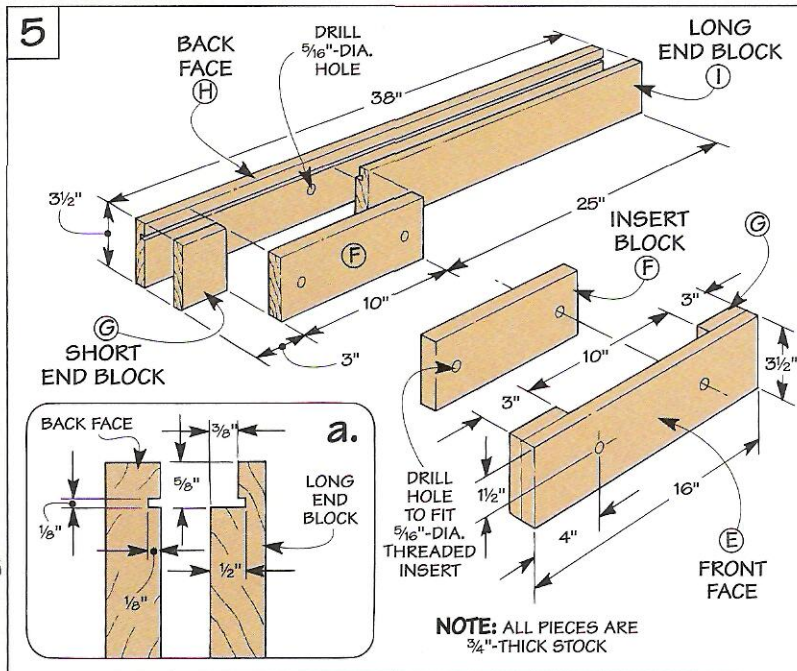

Adjustable Fence

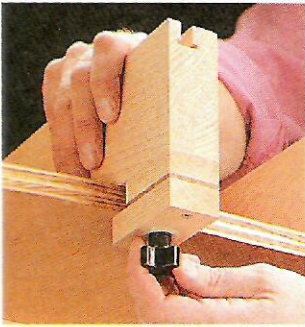

At this point, the cut-off table can be used for making 90° cuts. But to make angled cuts as well, I added an adjustable fence with a simple clamp that locks it in place, see Fig. 7 and photo.

T-SLOT. Like the fixed fence, a T-slot for a stop block runs along the top edge of the adjustable fence. After cutting two 3/4"-thick fence pieces (*L*) to size, this T-slot is made the same way as the one in the fixed fence, see Figs. 8 and 8a.

NOTCH. Once the fence is glued up, a notch is cut at one end. To provide a pivot point that lets you swing the fence to the desired angle, a knob passes through a hole drilled in the notch and into the threaded insert installed earlier, see Fig. 7a. Tightening (or loosening) the knob lets you attach (or remove) the fence.

CLAMP. Now you can add the clamp. It consists of three parts: a mounting block and arm made of hardwood, and a Masonite spacer in between, see Fig. 7b.

What makes this clamp work is the mounting block is *thinner* than the base. This way, the

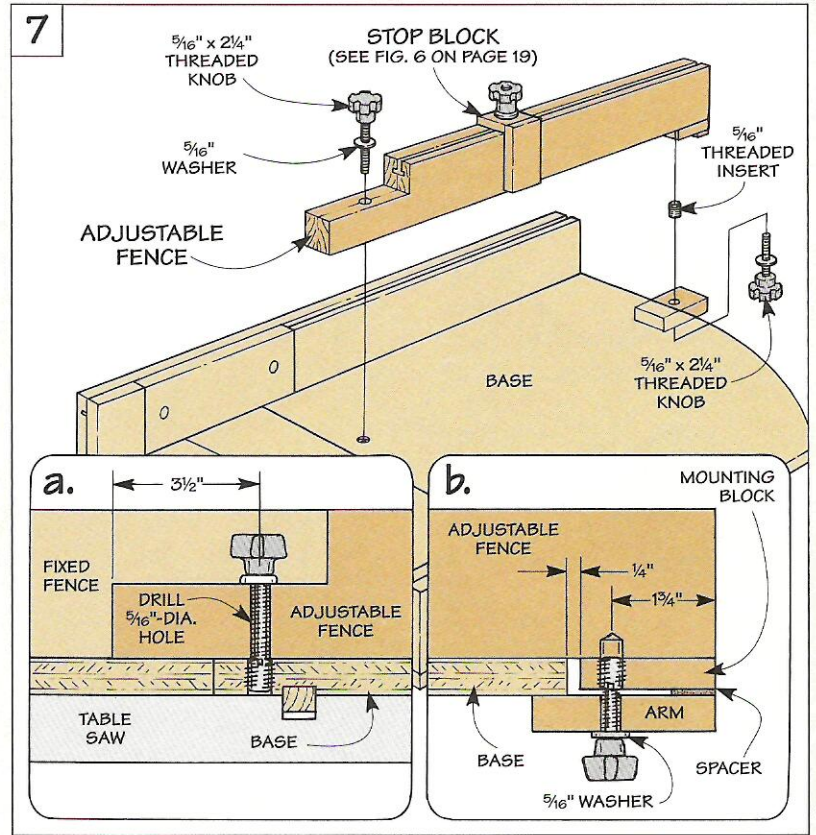

spacer creates a small gap that allows the arm to pinch against the base of the cutoff table when you tighten the clamp.

To provide this clamping pressure, the *mounting block* (*M*) and *spacer* (*N*) are first glued in place, see Fig. 9. After installing

a threaded insert in the mounting block and attaching the *arm* (*O*) with screws, a simple knob can be used to tighten the clamp, see Fig. 7b.

Finally, it's just a matter of adding a second stop block for the adjustable fence, see Fig. 7.

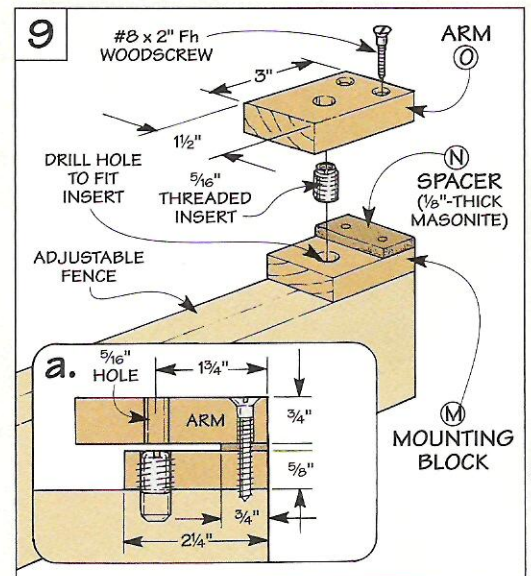
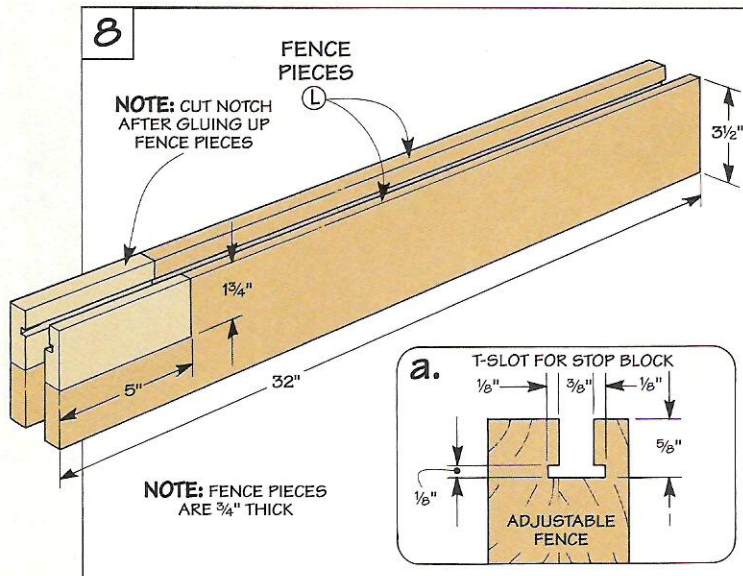

Stop System

All that's left to complete the sliding table is to add the stop system. Besides supporting the sliding table, it covers the exposed part of the blade that passes through the fixed fence at the end of a cut.

To make this work, the stop system consists of three parts: a support, a blade guard, and a pair of stop blocks, see Figs. 10, 11, and photo C on page 16.

SUPPORT. The *support* (P) is a long strip of wood that attaches to the extension wing of the table saw, see Fig. 10. It prevents the sliding table from tipping at the beginning and end of a cut.

To determine the length of the support, simply measure the depth of the saw table and add 12". (This gives you 6" of support at each end.) After cutting the support to length, it's just a matter of bolting it flush with the top of the saw table, see Fig. 10a.

BLADE GUARD. Now you can add the *blade guard* (Q), see Fig. 11. It's a thick block that's made by gluing up five pieces of 3/4"-

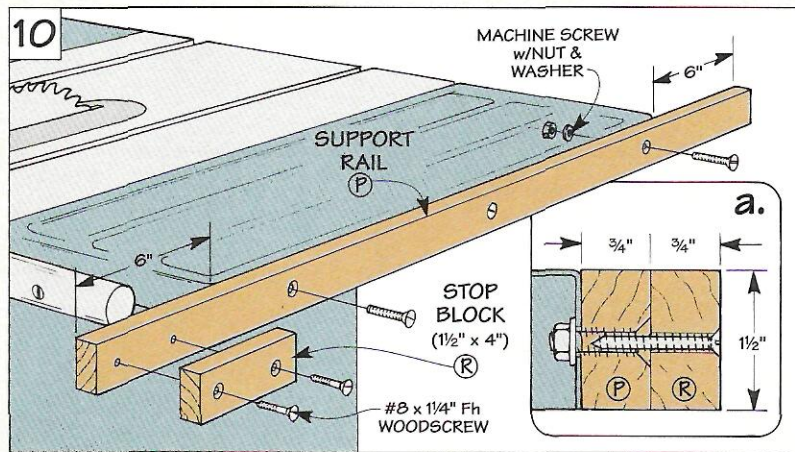

thick hardwood. In use, the part of the blade that cuts through the back of the fence is "buried" in this block at the end of a cut.

Before attaching the guard, I cut 1/2"-wide chamfers on all the outside edges. Then the blade guard is glued in place so it's centered behind the insert.

STOP BLOCKS. The last thing to do is to add two *stop blocks* (R). These blocks prevent the blade guard by creating a positive stop

at the end of a cut. One block is glued and screwed to the end of the support, see Fig. 10. The other attaches to the bottom of the cutoff table, see Fig. 12.

To determine the location of this block, position the cutoff table on the saw so the front of the fence is centered over the saw arbor, see Side View. Then glue and screw it in place. Note: An 1/8" gap between the block and support keeps the table from binding, see End View.

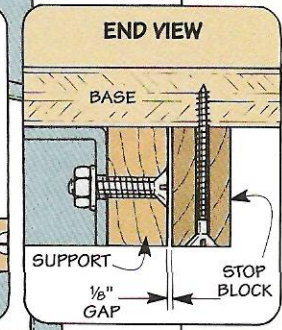
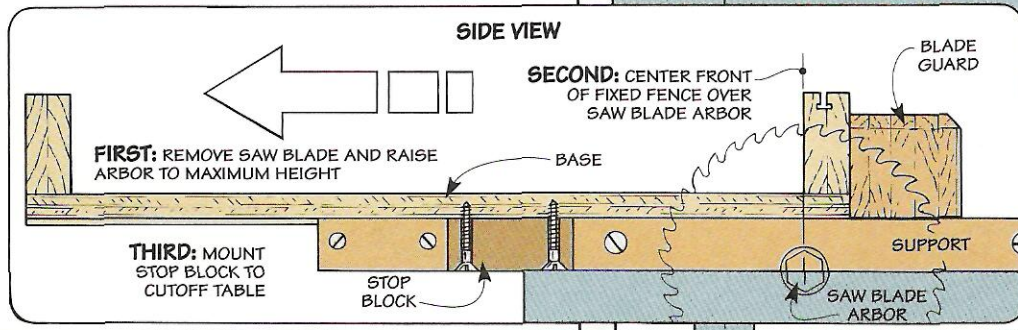
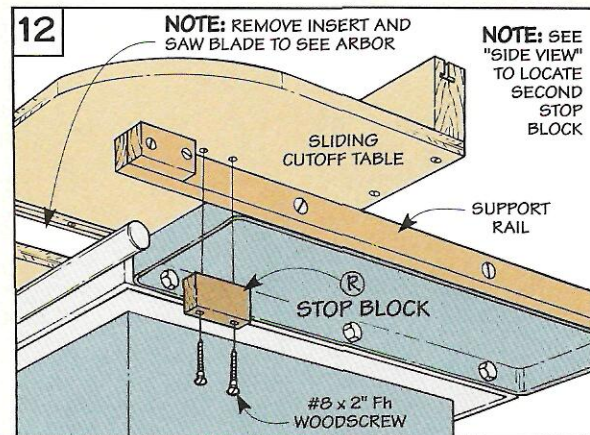
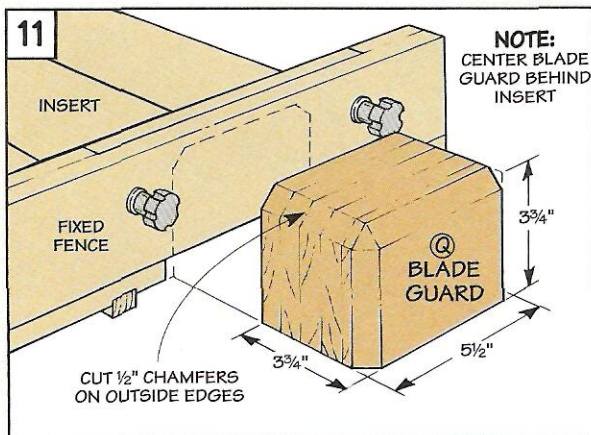

Drilling Holes

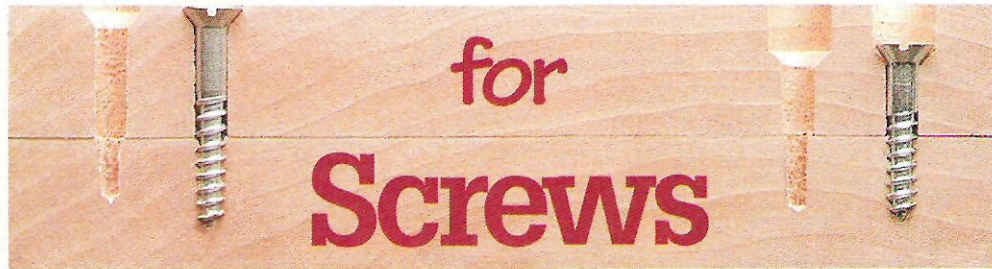

On the surface, assembling a project with screws is fairly straightforward. Just drill a hole (or a series of holes) and drive in the screws.

Maybe that's why it's so frustrating when things don't go exactly as planned. For example, the screw doesn't draw the pieces tightly together. Or the head of the screw snaps off.

If something like that happens, it's only natural to blame the screw. But more than likely, the real problem can be traced back to the holes that were drilled for the screws.

So when working with standard tapered woodscrews, I drill a series of stair-stepped holes to fit the shape of the screw as closely as possible. This can either be done with individual drill bits. Or you can use a special combination bit, see right-hand box on page 23.

TWO HOLES. To ensure a smooth assembly and a joint that's held tightly together, I start by drilling two holes. A large *shank hole* goes all the way through the top piece, see photo above and drawing in margin. And a small *pilot hole* stops in the base piece. Note: To drill these holes as accurately as possible, I use brad point bits.

SHANK HOLE. The shank hole provides clearance for the smooth part of the screw. And it keeps the threads in the top piece from "catching" and creating a

gap between the pieces, see Fig. 1.

SIZE. An easy way to select the right size drill bit for the shank hole is to hold the screw in front of the bit, see Fig. 2a. The sides of the bit should just barely stick out past the shank. Then when you drill the hole, the screw will slide through without binding, see Fig. 2.

PILOT HOLE. The next step is to drill the pilot hole in the base piece. The most important job of

the pilot hole is to prevent the wood from splitting.

To do this effectively, the pilot hole has to be sized correctly. If it's too large, the holding power of the screw is reduced. Too small and it increases the chances of splitting the wood or snapping the head off the screw.

As a rule, I drill the pilot hole slightly *smaller* than the root of the screw (the part of the screw

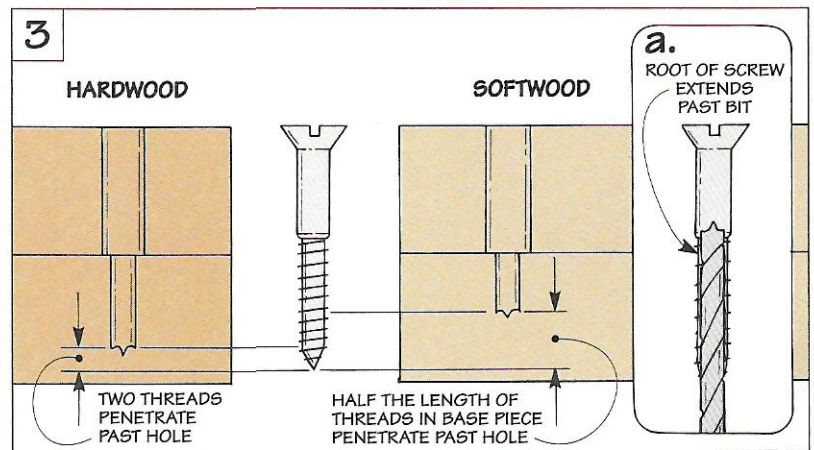
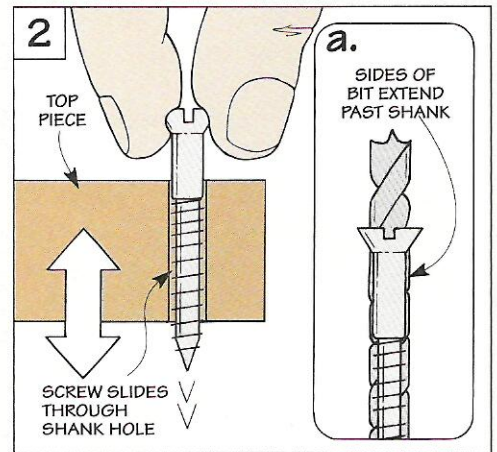
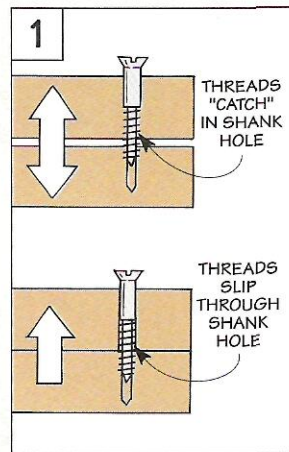
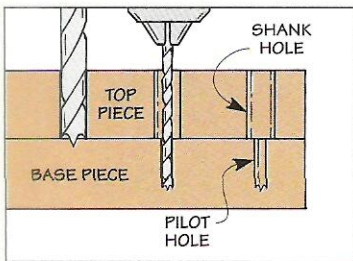

between the threads). This gives the threads something to grab.

Here again, to find the correct size drill bit, line up the bit with the screw. But this time, place the screw *behind* the bit, see Fig. 3a. The root of the screw should just peek past the sides of the bit.

DEPTH. Another thing to keep in mind is the depth of the pilot hole. This will vary depending on whether you're working with hardwood or softwood.

Since hardwood is more likely to split, I drill the hole almost as deep as the screw will penetrate, see Fig. 3. Leaving two or three threads to bite into the wood is plenty to produce a solid grip.

But with softwood, I drill a shallower hole — usually about half the length of the threaded part of the screw that will be in the base piece.

APPEARANCE

While the shank hole and pilot hole take care of the basic mechanics of a screw joint, you also need to consider the finished appearance of the screw head.

COUNTERSINK. On most shop projects, I drill a countersink. This leaves the screw head ex-

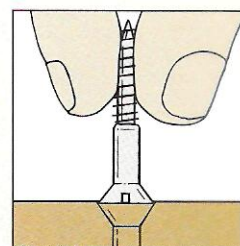
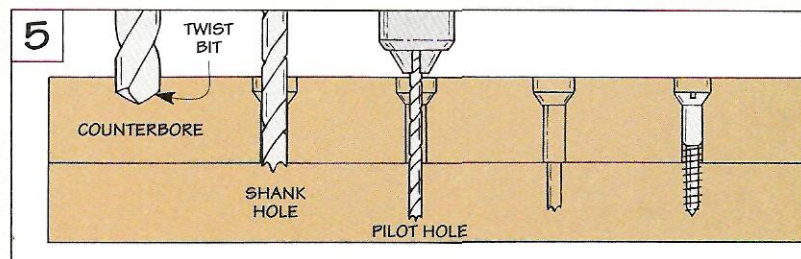
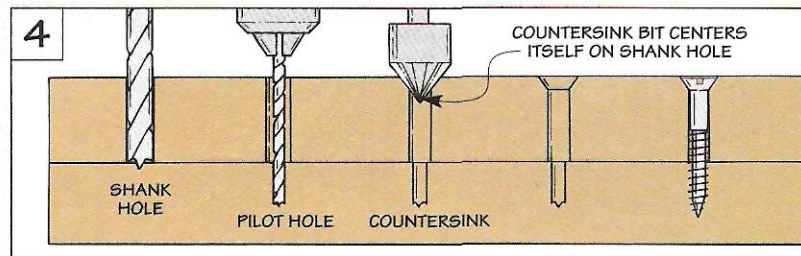

To set the screw head just below the surface, drill the countersink deep enough so the head fits the top of the opening.

posed and set slightly below the surface. The beveled sides of the countersink match the shape of the screw head so it can draw down tight.

The important thing is to drill the countersink *after* the shank hole and pilot hole, see Fig. 4. This way, the tapered sides of the bit automatically center it on the shank hole. (For more on countersink bits, see box below left.)

COUNTERBORE. For a finished appearance, a counterbore lets you recess the screw head below the surface. This is a deep,

straight-sided hole that's drilled to accept a wood plug or filler.

The thing to be aware of is the counterbore is drilled *before* the shank hole and pilot hole, see Fig. 5. (If you drill the shank hole first, the bit will wander because there's no centerpoint to guide it.)

So which bit do you use to drill a counterbore? Since a twist bit also forms a countersink at the base of the hole, it's a good choice for flathead woodscrews, see Fig. 5. But for a roundhead screw that's flat on the bottom, I use a brad point bit. 

Countersink Bits

There's a big difference in these two countersink bits. One uses a single cutting edge that slices the wood fibers and leaves a clean hole, see left-hand photo. The other has multiple cutters that scrape the wood and produce a scalloped cut, see right-hand photo.

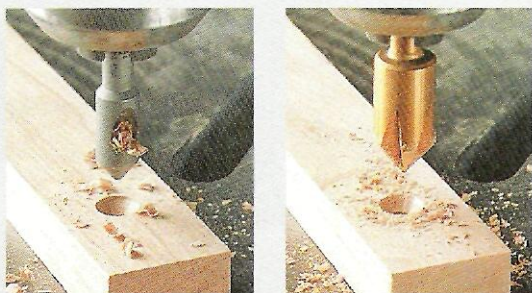

Combination Bit

If you're installing a lot of screws, this tapered combination bit saves time by drilling a series of holes in a single operation. You can use it to drill the countersink, shank hole, and pilot hole, see left-hand photo. Or adjust it to drill the counterbore as well, see right-hand photo.

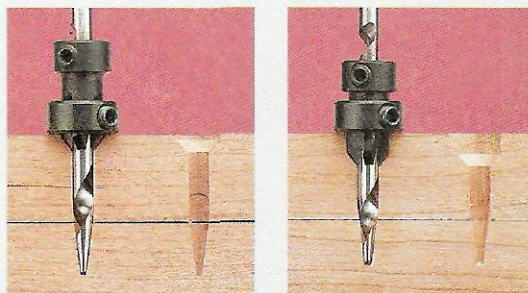

Sources

- Woodcraft (single & multiple cutter countersink, comb. bits)
800-225-1153
- Garrett Wade (combination bits)
800-221-2942
- Woodworker's Supply (single cutter countersink, comb. bits)
800-645-2942
- Constantine's (multiple cutter countersink, comb. bits)
800-223-8087

Pegboard Storage



Just open the doors to find the hidden storage space inside this compact rack.

At first glance, it's hard to imagine that you can organize a wall full of tools in this compact storage rack, see photo. But a closer look reveals the "hidden" storage space inside.

This extra storage is provided by two doors that have pegboard on both the front and the back. To provide easy access to tools on each side, the doors swing out in opposite directions, refer to the photos on the back page.

FRAME. The doors are supported by a sturdy frame made from "two-by" material (I used Douglas fir) and a 3/4"-thick plywood top and bottom, see drawing below left. It's held together

with simple (yet strong) lap joints that are made by cutting a series of notches in the frame pieces.

A pair of stretchers (A) used to attach the rack to the wall are rabbeted on each end, see Fig. 1. These rabbets fit dadoses in the back of the two uprights (B). Another pair of dadoses on the inside face accept short arms (C) that are rabbeted on one end.

Before assembling the frame, it's easiest to drill a hole in each arm for a pin that will allow the doors to pivot, see Fig. 2. And a shallow groove is cut for the top and bottom that are added later.

ASSEMBLY. Now you can assemble the frame. The stretchers, uprights, and arms are held together with glue and screws.

To add rigidity to the frame, the plywood top and bottom (D) are cut to fit between the grooves in the arms. But before gluing and screwing them in place, I

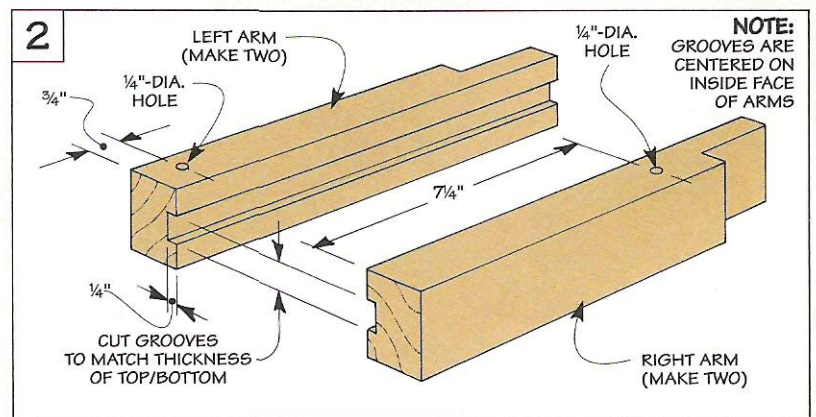
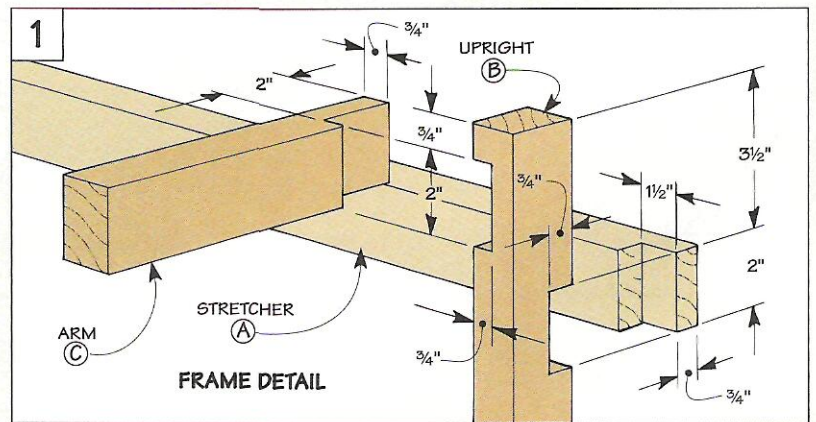
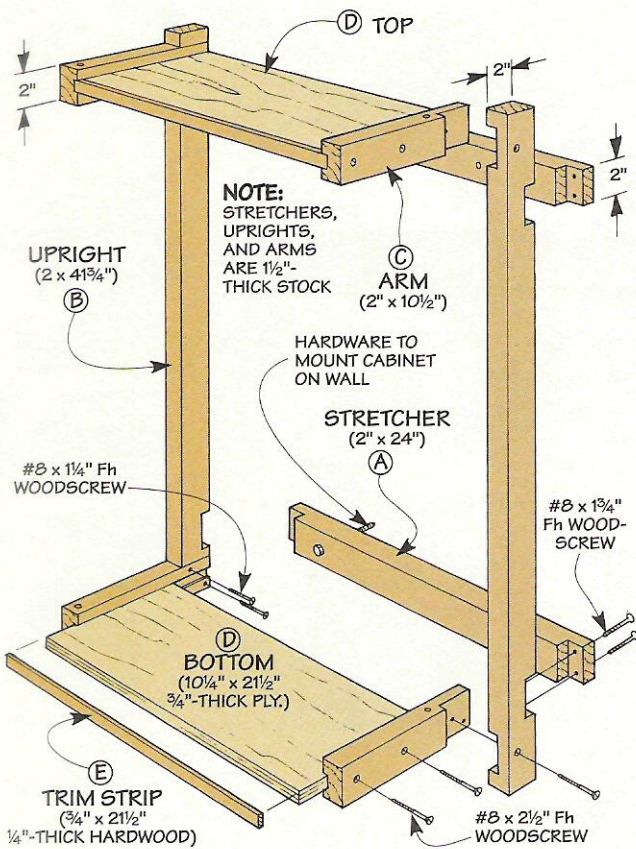

added hardwood *trim strips (E)* to cover the front edges.

DOORS

With the frame complete, you can add the doors. They're just simple wood frames with pegboard on each side, see Fig. 3.

The overall height of the doors is the same. But the back door is 1" narrower so it swings past the front door when you open it, see Fig. 3d.

Determining the length of the frame pieces is easy. The *stiles (F)* on each door are identical in length. (To provide an $\frac{1}{8}$ " clearance at the top and bottom, I cut them 36" long.) But the *front rails (G)* are 1" longer than the *back rails (H)*. (This takes into account the overall width of the doors and the joinery that holds them together.)

With the frame pieces cut to length, matching rabbets are cut on both sides for the pegboard panels, see Fig. 3a. And a notch in the ends of the stiles accepts the rails, see Fig. 3b.

PANELS. After screwing the frame pieces together, it's just a matter of cutting *front (I)* and *back door panels (J)* to fit and screwing them in place, see Fig. 3c. And a scrap *pull (K)* is glued to the front of the back door.

ATTACH DOORS. All that's left is to attach the doors. They pivot on two hex bolts that pass into bronze bushings installed in the top and bottom edges of each

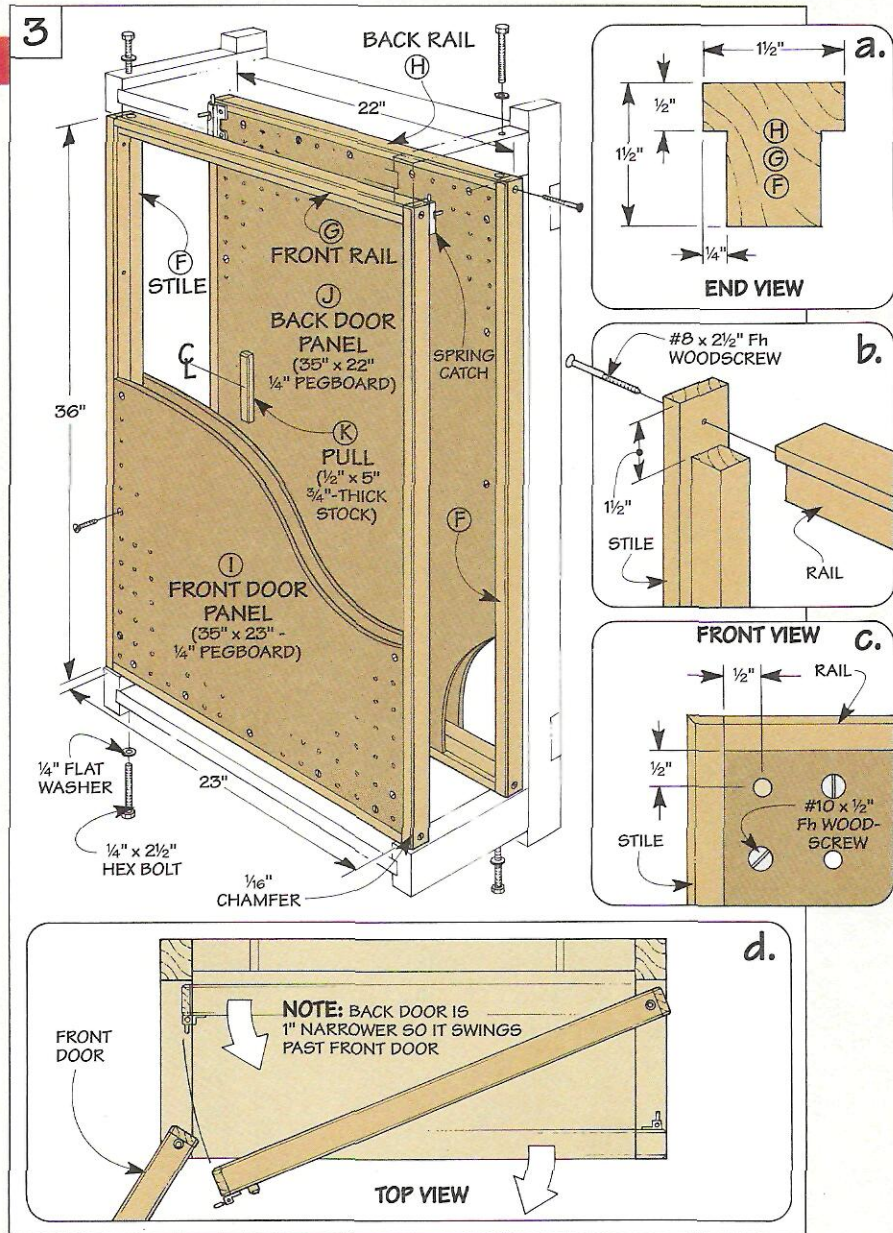

door, see Fig. 4. and 4a. These bolts pass through holes in the arms (drilled earlier) and thread into T-nuts in the inside face of the arms.

Finally, to lock the doors in

place, a hole is drilled in each upper arm for a spring loaded catch, see Fig. 5. Note: One catch mounts to the back of the front door. And the other is on the front of the back door, refer to Fig. 3.

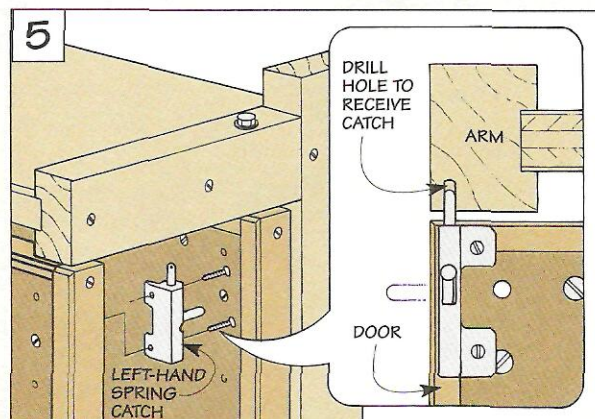
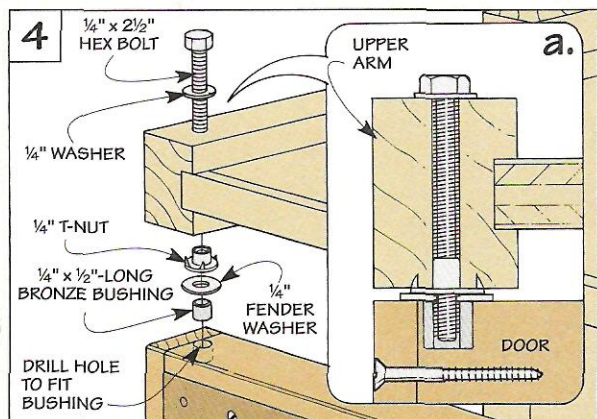

Hardware

- (8) #8 x 1/4" Fhws
- (20) #8 x 2 1/2" Fhws
- (8) #8 x 1 3/4" Fhws
- (80) #10 x 1/2" Fhws
- (4) 1/4" x 2 1/2" Hex Bolts
- (4) 1/4" Flat Washers
- (4) 1/4" Fender Washers
- (4) 1/4" T-nuts
- (4) 1/4" x 1/2"-long Bronze Bushings
- (2) Left-Hand Spring Catches w/Screws

To order a complete hardware kit call: 1-800-347-5105 6827-300.....\$20.95

Quick Clamps

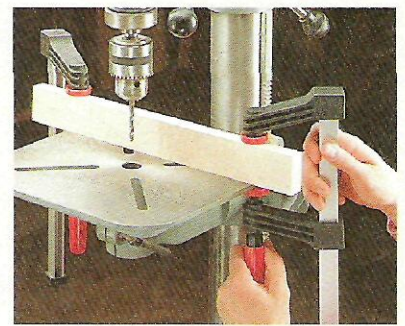
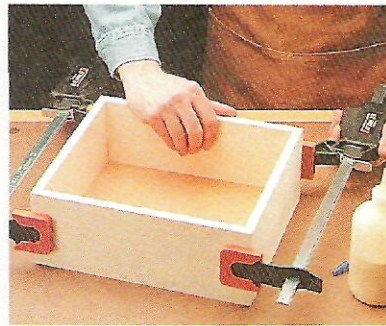
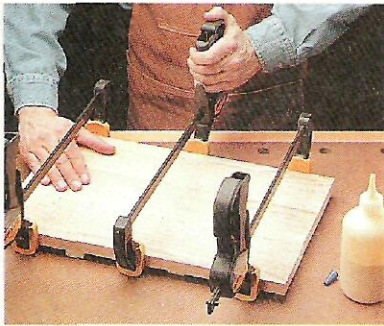

Prices

E-Z Hold

10" clamp \$11.95
16" clamp \$12.95
22" clamp \$13.95
28" clamp \$15.95

Quick-Grip

12" clamp \$16.95
18" clamp \$17.95
24" clamp \$19.95
36" clamp \$22.95

Quick-Star

8" clamp \$23.95
12" clamp \$27.50

There's one thing that's always in short supply when clamping up a project — a third hand. With one hand positioning the clamp, and the other keeping the parts aligned, an extra hand to tighten the clamp would speed things up considerably.

That's where these quick clamps come in, see photos below and prices in margin. They free up one hand by allowing you to position the clamp and apply

pressure with the other hand.

But there's more to a clamp than how handy it is to use. To see how they performed when gluing up a project or making a tool setup, we ran the clamps through a series of tests, see photos above.

To provide a range of viewpoints, we asked three woodworkers with different amounts of experience to test the clamps: *Cary* (a weekend woodworker), *Steve* (an advanced woodworker),

and *Ken* (a professional carpenter and cabinetmaker).

Q: *These clamps look quite different from each other. Do they work differently too?*

Steve: The two clamps that are the most alike are the E-Z Hold and Quick-Grip. With these, I just squeeze the handle to slide the lower jaw along the bar until it's tight against the workpiece.

Ken: While both clamps use a pumping action to advance the jaw, I liked the in-line handle on the E-Z Hold the best. (See the top drawing at left.) That's because no matter how the clamp is oriented, it's convenient to use.

But since the pistol grip on the Quick-Grip is perpendicular to the bar, it can be awkward to use depending on the position of the clamp. (See center drawing.)

Cary: The Quick-Star uses a different approach altogether. The lower jaw on this clamp is spring-loaded, so it advances "automatically" like a tape measure. (See bottom drawing.)

Q: *How does that work?*

Cary: It's pretty simple really. Pulling the lower jaw down the bar applies tension to the spring. And releasing it retracts the spring and pulls the jaw against the workpiece.

Once the jaw is snug, it works like a standard bar clamp. As you

**E-Z Hold
(Jorgensen)**
312-666-0640

**Quick-Grip
(American Tool)**
800-767-6297

**Quick-Star
(Gross Stabil)**
800-671-0838

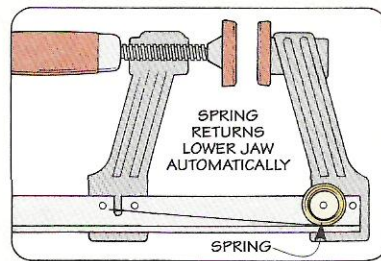
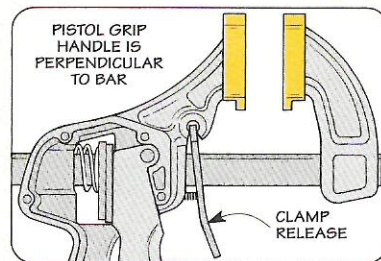
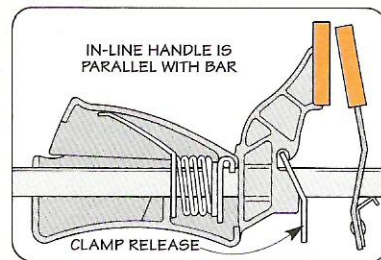

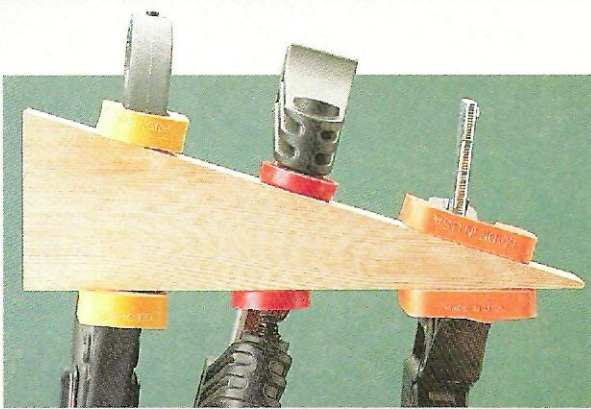

Irregular Shapes. Unlike the Quick-Grip (left), the clamp pads on the Quick-Star (center) and E-Z Hold (right) make full contact with irregular-shaped objects.

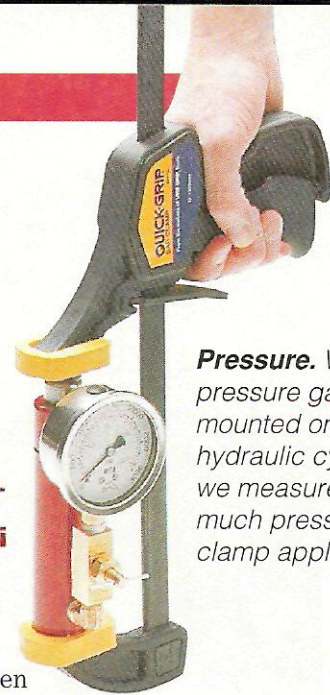
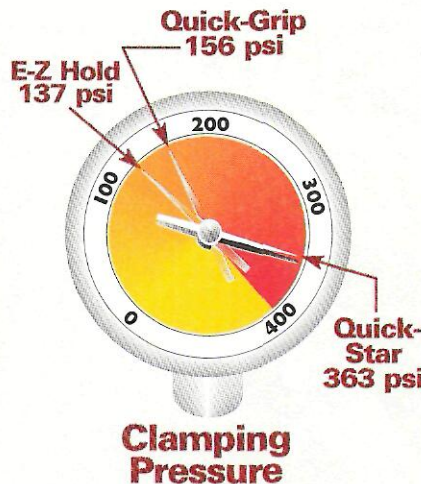

Pressure. With a pressure gauge mounted on a hydraulic cylinder, we measured how much pressure each clamp applied.

tighten the handle, a screw applies the clamping pressure. Which is why the Quick-Star applies more pressure than the other two clamps. (See drawing and photo above right.)

Ken: But that's not to say you can't get a tight fitting glue joint with the E-Z Hold and Quick-Grip. Since they don't produce as much clamping pressure, the key is to make sure the joint fits tight *before* gluing the pieces together. And since I do that anyway (even

when using heavy-duty clamps), that's not a big deal.

Q: What about the clamp heads?

Cary: That's one of the biggest differences I noticed. Because both clamp heads on the Quick-Grip are fixed, the pads don't make full contact when I clamp an irregular-shaped object. (See photo above left.)

But the lower clamp head on the Quick-Star is basically just a ball and socket joint. So the head

pivots as I tighten the clamp and the pads conform to the shape of the object.

Steve: While it doesn't have quite as much flexibility, the upper clamp head on the E-Z Hold also pivots.

In fact, the whole upper jaw slides off the bar so I can use it as a spreader. That's handy when I need to take a project apart after dry assembling it to check the fit. (See margin.)

Q: One last question. Besides the color, are there any real differences between the clamp pads?

Steve: Size is one thing. The large pads on the E-Z Hold and Quick-Grip seemed to distribute pressure farther along the joint line than the small pads on the Quick-Star. (See photos at left.)

Cary: And I liked the positive grip provided by the soft, rubbery pads on both the E-Z Hold and Quick-Grip.

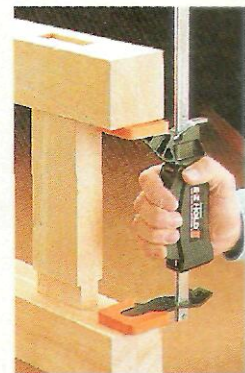

Simply reversing the jaws on the E-Z Hold clamp allows you to use it as a spreader.

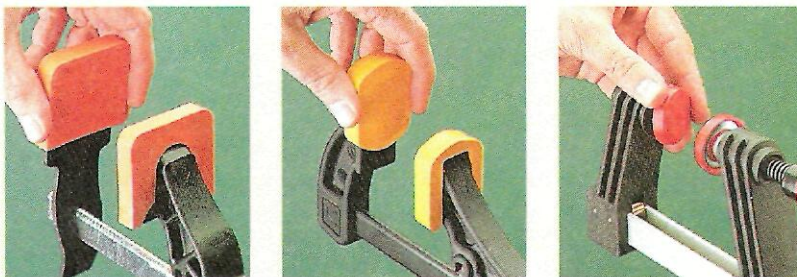

Clamp Pads. The large jaws and the soft rubbery clamp pads on the E-Z Hold (left) and Quick-

Grip (center) provide a more stable grip than the smaller plastic pads on the Quick-Star (right).

Recommendations

Cary: Choosing the best quick clamp was a tug of war.

I liked the spring-loaded jaw and the extra clamping pressure you get with the Quick-Star. But not enough to pay over \$20 for it.

So I picked the E-Z Hold instead. It only costs about half as much. And it would easily handle most of my clamping needs.

Steve: At first, it was the low cost of the E-Z Hold clamps that caught my eye too. (Especially if you're buying a bunch of clamps.)

But the real reason I picked the E-Z Hold was the convenience of the in-line handle. Also, converting the clamp to a spreader is something that would come in handy for me once in awhile.

Ken: I guess that makes three of us. Although it doesn't produce as much clamping pressure, I chose the E-Z Hold too.

It exerts plenty of pressure if you start with a tight-fitting joint. And the large clamping surface provided by the soft, rubbery pads distributes pressure evenly along the joint line. 🐶

Shop Solutions

Spring-Loaded Hold-Down

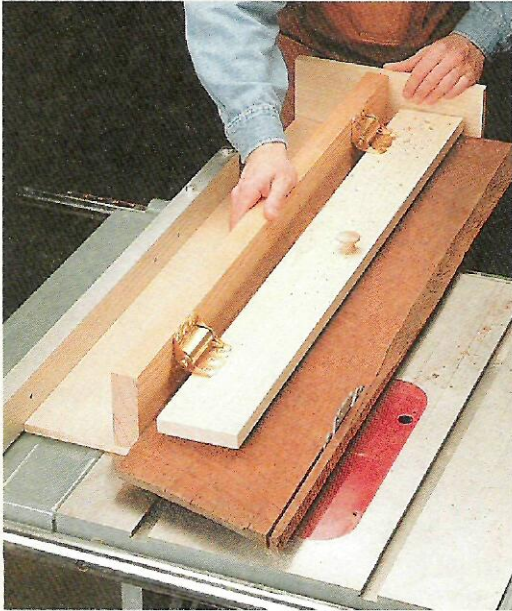

■ Like many woodworkers, I use a shop-made “sled” to rip a straight edge on rough cut lumber. But rather than buy special clamps to hold boards securely to the sled, a pair of spring-loaded hinges applies all the pressure I need, see photo.

One leaf of each spring is attached to a rail that’s screwed to

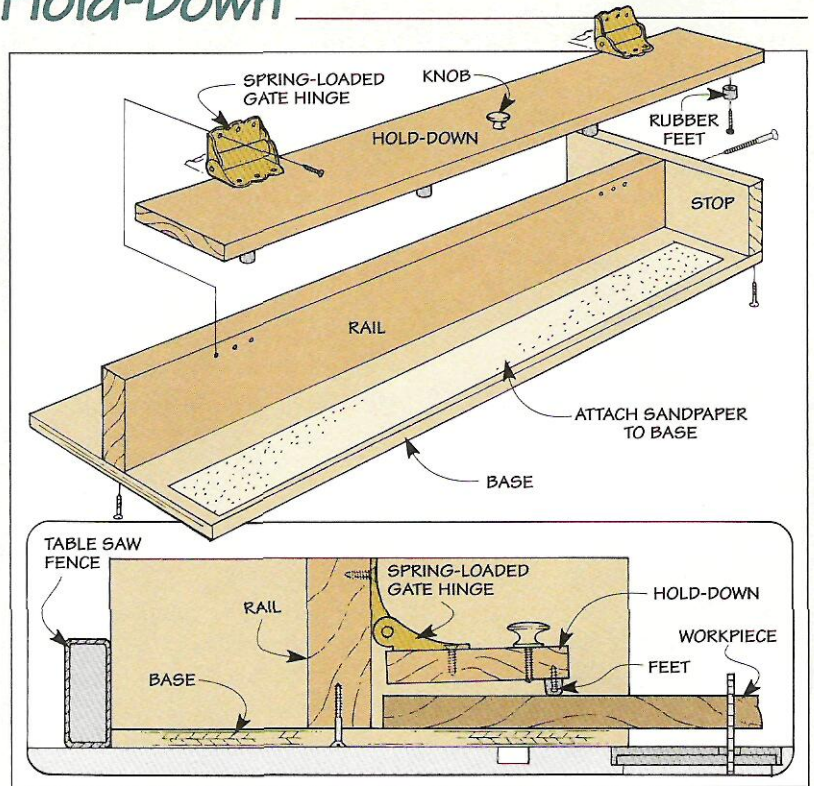

the base of the sled, see drawing. And the other fastens to a board that acts as a hold-down.

To hold the workpiece securely in place, I screwed rubber “feet” to the bottom of the hold-down

and glued sandpaper to the base.

And a stop glued and screwed to the end of the base helps push the workpiece when making a cut.

Terry Vikla

Cottage Grove, Minnesota

Brad & Nail “Drill Bit”

■ Predrilling a pilot hole for a brad or finish nail helps prevent them from splitting the wood. But I don’t always have a drill bit that’s the same size as the brad or finish nail.

To drill holes that are the exact size, I cut the head from one of the brads or nails I’m using and chuck the shank in my drill. The shank works like a drill bit to drill a hole that fits the brad or nail perfectly.

David Krimmel
San Diego, California

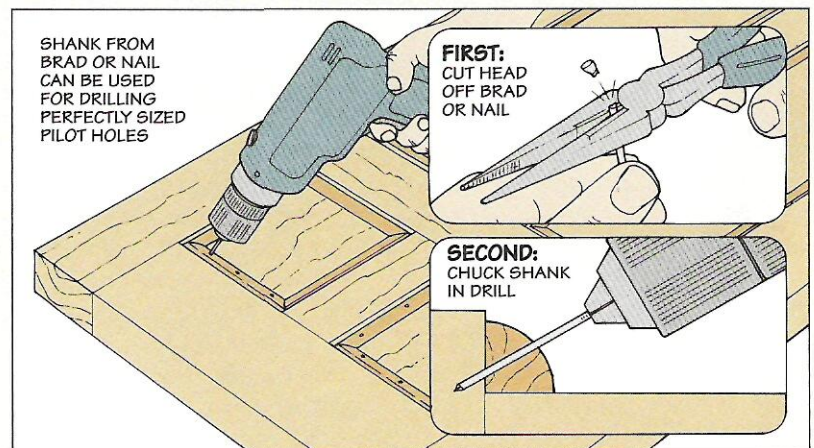

Quick Tips

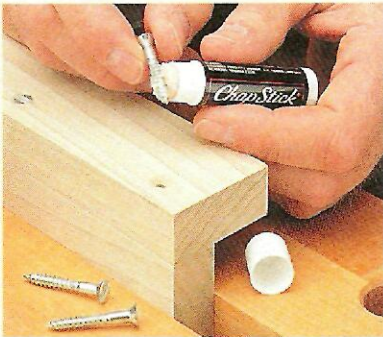

▲ Since his lip balm is always handy, **Bill Johnson** of Akron, Ohio, applies it to screw threads to make the screws easy to drive.

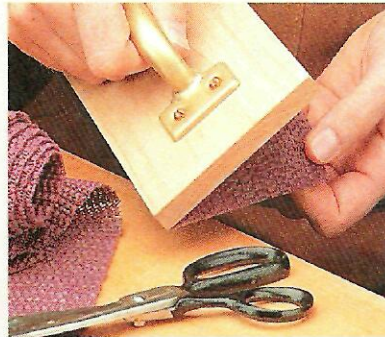

▲ To increase the grip of his push block, **John French** of San Diego, California, glues shelf liner to the bottom of the block.

► Right out of the package, it's easy to identify the grit on a hook and loop sanding disk. But if you change disks frequently, the grit markings on back soon wear off.



So **Wayne Loper** of Duncannon, Pennsylvania, uses a permanent marker to label the grit on the one place on the front of the disk that doesn't clog or wear out — the center of the disk.

Finishing Easel



■ To make it less tiring on my back when finishing doors and other flat projects, I built an "easel" that holds the workpiece at a comfortable height, see photo.

The main parts of the easel are a pair of uprights made from "two by" material that are set up on a sawhorse, see drawing. A square notch in the bottom of each upright fits behind a stretcher screwed to the legs of the sawhorse, see detail 'b'. And an angled notch in the back edge determines the slope of the easel.

To keep the uprights from tipping, I drilled two holes in each one for a pair of long dowels. By gluing and screwing one end of

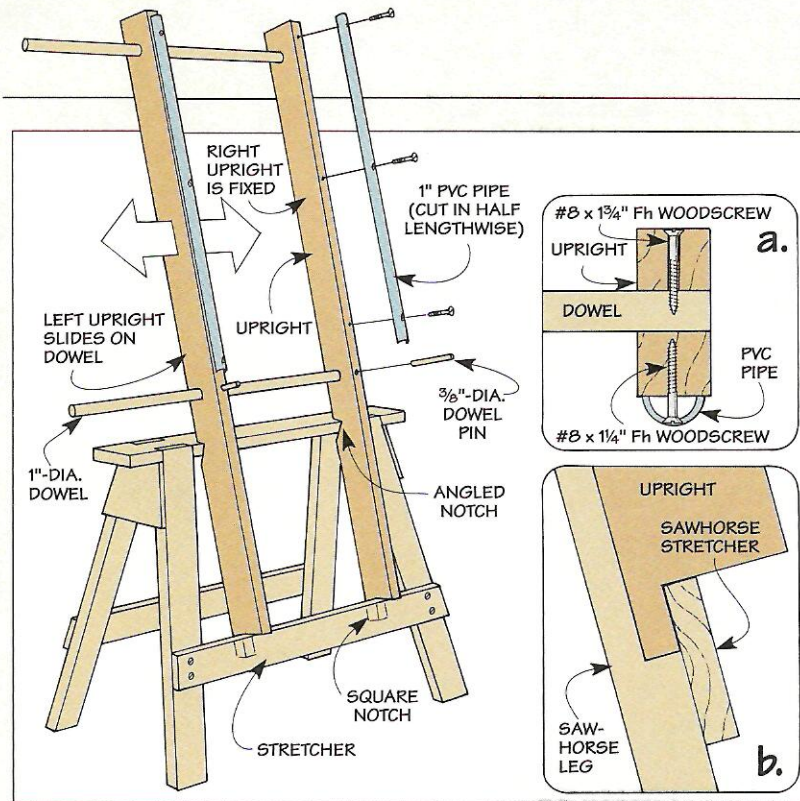

each dowel to the same upright, you can slide the other one on the dowels to adjust the easel for projects of different widths.

Finally, a dowel in the front edge of each upright supports the workpiece. And a piece of PVC pipe that's cut in half (lengthwise) and screwed to the uprights keeps the wet finish on the project from sticking to the easel, see detail 'a'.

*Allan Gabel
Sussex, Wisconsin*

Send in Your Solutions

If you'd like to share your original solutions to problems you've faced, send them to: *ShopNotes*, Attn.: Shop Solutions, 2200 Grand Avenue, Des Moines, IA 50312. (Or if it's easier, FAX them to us at: 515-282-6741.) We'll pay up to \$200 depending on the published length. Please include a daytime phone number so we can call you if we have any questions.

Redwood

There's a good reason why the houses my grandfather built still have their original wood siding. The siding is made from redwood.

And even though the finish on many of those homes has deteriorated over the years, the redwood is still as solid as the day he nailed it in place. That's because redwood has a natural resistance to both insects and decay.

Because of this durability, redwood is an ideal wood for a project that's going to sit outside (like the picnic table on page 10). But to take advantage of its ability to fend off damaging insects and rot, you'll need to take a close look at the different grades of redwood.

TWO GROUPS. Although there are a number of different grades, each one falls into one of two main groups: Heartwood or Sapwood.

When buying redwood for an outdoor project, I make it a point to select Heartwood lumber. Heartwood is easy to identify by its reddish-brown color, see photos at right. But there's something about it that's even more important than color.

The heartwood is cut from the inner part of a redwood log — the part that makes it resistant to insects and decay. But there's no natural resistance in the sapwood that's cut from the outer part of the log.

HEARTWOOD. The two best grades of Heartwood are Clear All Heart (straight grain, free of knots) and Heart 'B' (some irregular grain and a few small, tight knots), see photos below. Note: We used Heart 'B' on the picnic table.

Not surprisingly, these two grades of redwood are also the most expensive. Here in Des Moines, Clear All Heart costs about \$4.40 a board foot, and Heart 'B' is \$3.50 a board foot.

A less expensive grade you may want to consider for some projects is Construction Heart/Deck

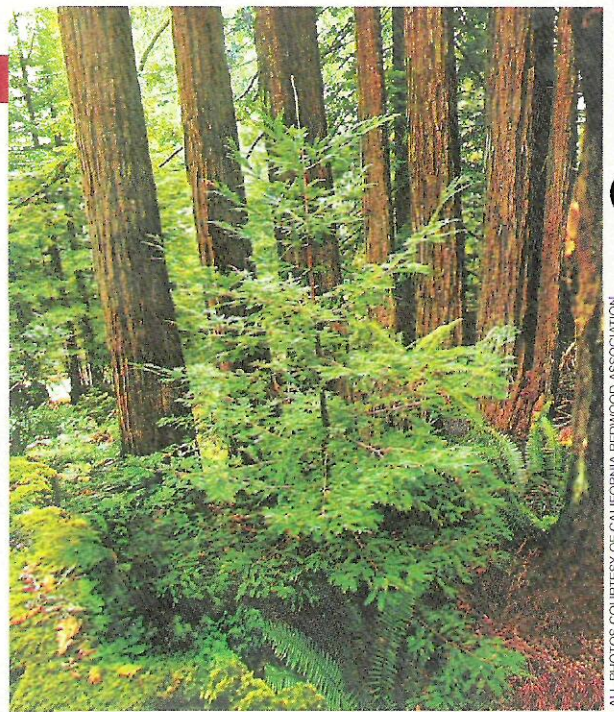

ALL PHOTOS COURTESY OF CALIFORNIA REDWOOD ASSOCIATION

Heart (\$1.50 a board foot), see bottom photo. Although boards in this grade aren't as straight grained and have larger knots, you can sometimes cut around them.

WORKABILITY. Regardless of the grade you use, there are a few things you should keep in mind when working with redwood lumber. Like most other softwoods, redwood cuts easily. But to help reduce splintering, it's still a good idea to first drill pilot holes before nailing or screwing it in place.

And if there are any small splinters along the edges, glue them in place before sanding or finishing as they have a tendency to "catch" on sandpaper, paintbrushes, and rags.

Also, when routing redwood, it's best to sneak up on the profile by making a number of passes to reduce tearout and splintering.

AVAILABILITY. Because redwood is such a specialty use item, you're not likely to come across it at your local home improvement center. But you can find it (or order it) at many lumberyards.

If you have trouble locating redwood, you can give the California Redwood Association a call (415-382-0662) for the nearest dealer in your area. 

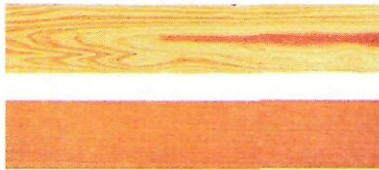

Color. Unlike the creamy colored sapwood (top), the red heartwood resists insects and decay.

Clear All Heart. Lumber with this grade is straight-grained and free of knots.



Heart 'B'. You'll see some irregular grain and small knots in Heart 'B' lumber.



Construction Heart/Deck Heart. Look for knots of varying sizes with this grade.



Outdoor Finishes

Whether it's drenched in the rain or baked by the sun, the finish on a piece of outdoor furniture has an incredibly tough job. So it's important to select a finish that protects the wood from damage caused by extremes of weather.

In addition, there are a couple other things I look at before choosing an outdoor finish. How it affects the appearance of the project for instance. And the maintenance required to preserve the finish.

To strike a balance between all these things, I usually select from three different types of outdoor finishes: penetrating oil, spar varnish, or paint.

PENETRATING OIL

The easiest finish to apply is a penetrating oil that's specially formulated for outdoor use. Wiping the oil on and off (I apply at least three coats) seals out moisture by penetrating *inside* the fibers of the wood.

Since the oil doesn't build up on the surface, it won't crack or peel. And it preserves the natural look and feel of the wood, see photo A.

MAINTENANCE. But it doesn't take long before an oil finish starts to look dull and loses its ability to keep out moisture. So about every two or three months, you'll need to wipe on a fresh coat.

SPAR VARNISH

For a more durable finish that still preserves the natural beauty of the wood, I use an exterior (marine) spar varnish, see photo B. It forms a protective barrier against moisture on the *surface* of the wood. And it's extremely resistant to wear.

FILTERS. When selecting a spar varnish, look for one with ultra-violet (UV) filters. These filters absorb the UV rays from the sun that break down a finish over time.

To take advantage of the filters, it's best to apply at least three coats of spar varnish. But since the filters gradually lose their effectiveness, you'll need to establish a regular maintenance schedule.

The important thing is to renew the finish *before* it starts to deteriorate. About once a year, I sand the finish lightly and apply another coat.

PAINT

Although it hides the wood, a good coat of paint still provides the best protection against the weather. That's because it keeps out moisture *and* prevents sunlight from penetrating the finish.

As with any finish, the end result is only as good as what's underneath. So start by applying a heavy coat of penetrating (outdoor) oil. Especially on end grain that will wick up moisture if the paint fails.

PRIMER. When the oil dries completely (about two or three days), the next step is to apply a good quality alkyd (oil-based) primer. While it provides excellent resistance to water, an alkyd paint can crack as the wood moves with changes in humidity.

TOP COATS. So when it's time to apply the top coats, I use a more flexible latex (water-based) paint, see photo C. Two coats will usually protect the wood for several years or more. 🐶

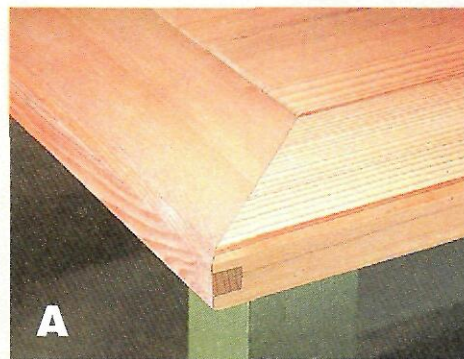

◀ **Penetrating Oil.** Even though it darkens the wood, the most natural looking outdoor finish is a penetrating oil. To ensure continuous protection against moisture, apply another coat of oil every few months.

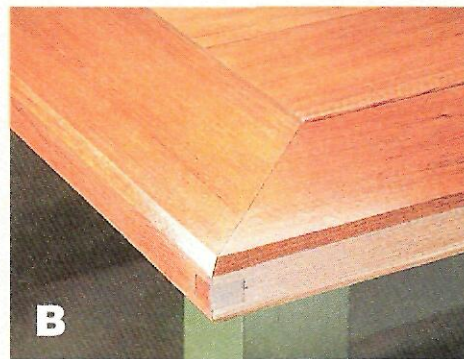

◀ **Spar Varnish.** With an exterior spar varnish, you get a more durable (and glossier) finish. Even so, you'll need to maintain the finish about once a year to prevent cracking or peeling.

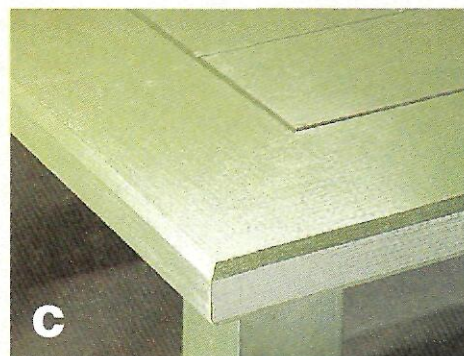

◀ **Paint.** While it hides the natural beauty of the wood, a painted finish offers the best protection against the weather. And you don't have to worry about renewing the finish as frequently.

Scenes from the Shop

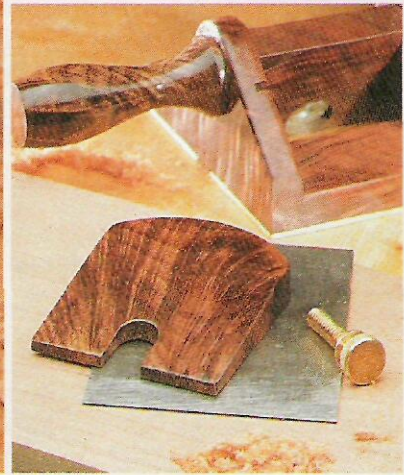
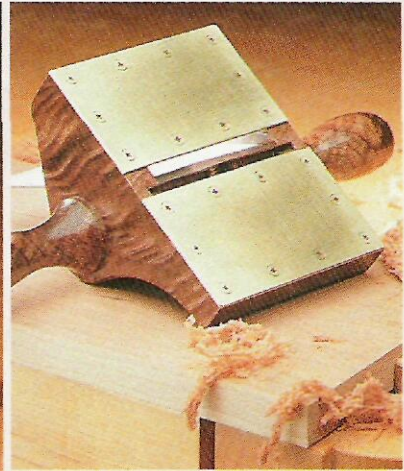

▲ The highly figured grain on this walnut scraper plane creates a fine tool that's as pleasing to look at as it is to use. Like the scraper plane shown on page 4, a

wood wedge and brass finger screw hold the scraper at just the right angle to produce thin, wispy shavings. And brass sole plates on the bottom resist wear.

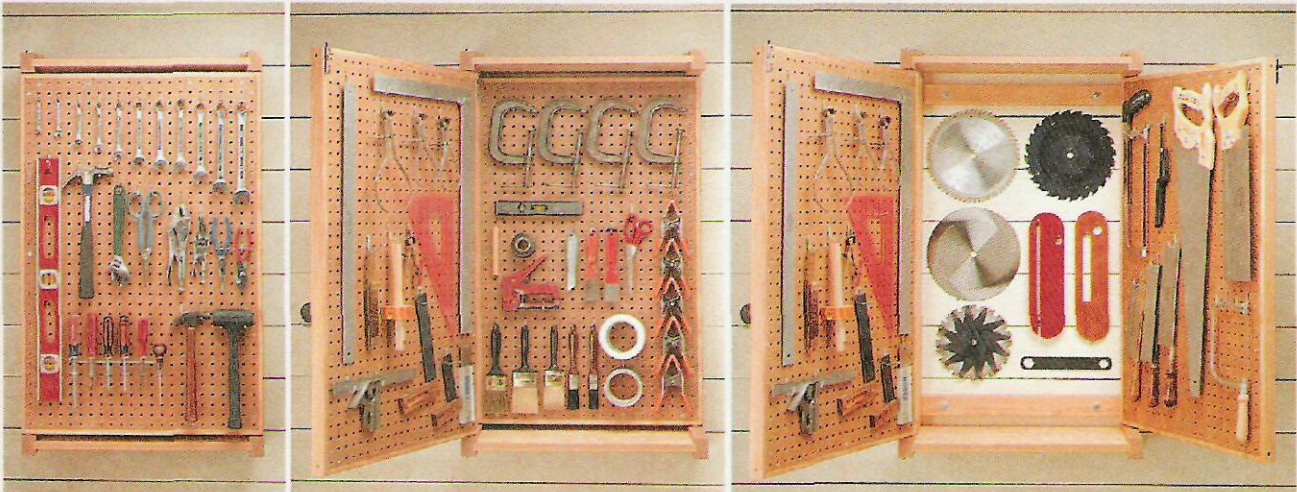

▲ A panel full of tools is just part of the storage provided by the pegboard rack shown above left and on page 24. Open the front door and there's storage on the

other side as well as a back door concealed within (center). Swing out the back door and you can even hang tools on the other side of it or the wall (right).