

# ShopNotes®

Vol. 5

Issue 30

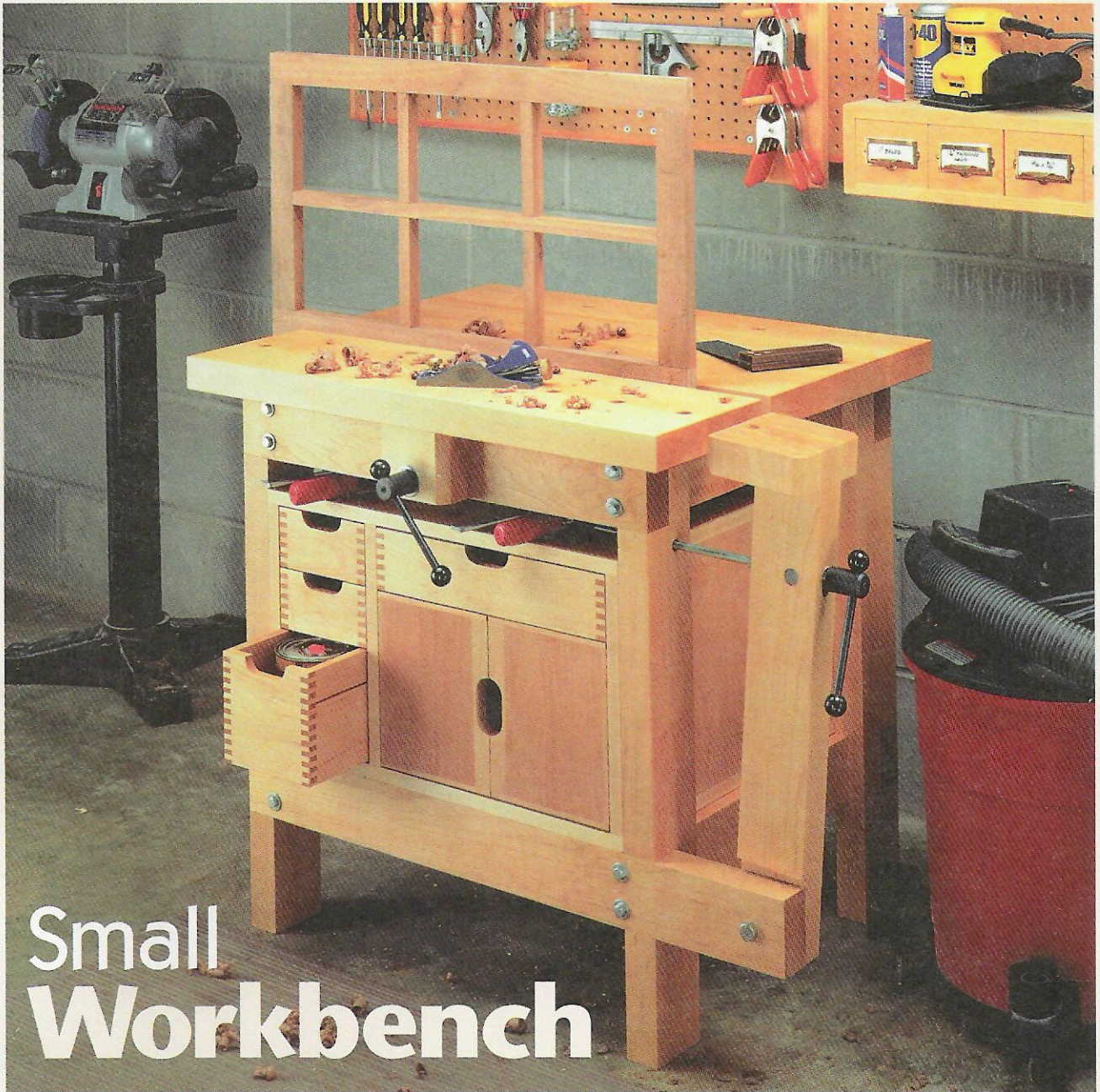

## Small Workbench

- Plunge Router Review
- Drop-Down Tool Tray
- Adjustable Assembly Table
- Wood Moisture



# ShopNotes®

Issue 30 November 1996

**PUBLISHER** Donald B. Peschke  
**EDITOR** Tim Robertson  
**ASSOCIATE EDITOR** Phil Totten  
**ASSISTANT EDITOR** Bryan Nelson  
**ART DIRECTOR** Cary Christensen  
**SENIOR ILLUSTRATORS** Kurt Schultz  
 Roger Reiland  
 Mark Higdon

## CREATIVE RESOURCES

*Creative Director:* Ted Kralicek • *Project Developer:* Ken Munkel • *Project Designer:* Ted Wong • *Shop Mgr.:* Steve Curtis • *Shop Craftsman:* Steve Johnson • *Photography Dir.:* Lark Gilmer • *Sr. Photographer:* Crayola England

## BOOKS

*Executive Editor:* Douglas L. Hicks • *Art Director:* Linda F. Vermaie • *Sr. Graphic Designer:* Chris Glowacki

## CIRCULATION

*Circ. Dir.:* Susan DuBois • *Sub. Mgr.:* Sandy Baum • *Renewal Mgr.:* Paige Rogers • *Asst. Direct Mail Mgr.:* Julie Greenlee • *Asst. Sub. Mgr.:* Joy Krause • *Assoc. Graphic Design Dir.:* Susie Rider • *Sr. Graphic Designer:* Cheryl L. Simpson

## CORPORATE SERVICES

*Vice Pres. of Planning & Finance:* Jon Macarthy • *Controller:* Robin Hutchinson • *Sr. Accountant:* Laura Thomas • *Accts. Payable Clerk:* Mary Schultz • *Prod. Dir.:* George Chmielarz • *Elect. Pub.:* Douglas M. Lidster • *Prod. Artist:* Jon Snyder • *Pre-Press Image Spec.:* Troy Clark • *Elect. Comm. Coord.:* Gordon C. Gaippe • *Net. Admin.:* Al Barnes • *Prof. Develop. Dir.:* Joyce Moore • *Human Res. Asst.:* Kirsten Koelke • *Admin. Asst.:* Julia Fish • *Recept.:* Jeanne Johnson, Sheryl Ribbey • *Bldg. Maint.:* Ken Griffith

## MAIL ORDER

*Operations Dir.:* Bob Baker • *Art Dir.:* Cindy Scarpino • *Materials Mgr.:* Mark Mattiussi • *Cust. Service Mgr.:* Jennie Enos • *Nat'l. Sales Mgr.:* Kent A. Buckton • *Warehouse Supr.:* Nancy Johnson • *Buyer:* Linda Jones • *Sys. Op.:* Tammy Aldini • *Team Leader:* Karla Eslinger • *Tech. Support:* Dave Stone • *Cust. Service Reps.:* Jennifer Murphy, Anna Cox, Kristi Andrews, Margo Petrus • *Warehouse:* Chuck Carlson, Sylvia Carey, Larry Prine, Scott Gilliam

ShopNotes® (ISSN 1062-9696) is published bimonthly (Jan., March, May, July, Sept., Nov.) by August Home Publishing, 2200 Grand, Des Moines, IA 50312.

ShopNotes® is a registered trademark of August Home Publishing ©Copyright 1996 by August Home Publishing. All rights reserved.

**Subscriptions:** Single copy: \$4.99. One year subscription (6 issues), \$24.95. Canada/Foreign add \$5 per year.

**Periodicals Postage Paid** at Des Moines, IA and at additional mailing offices.

**Postmaster:** Send change of address to ShopNotes, P.O. Box 37103, Boone, IA 50037-2103.

**Subscription Questions?** Write to: ShopNotes Customer Service, P.O. Box 842, Des Moines, IA 50304-9961. Or call 1-800-333-5854, 8:00 am to 5:00 pm, Central Time, weekdays. FAX 515-283-0447

E-Mail: ShopNotes@aol.com

Internet: http://www.augusthome.com

PRINTED IN U.S.A.

## WoodNet™

### NOW ON THE WEB!

- 50 Woodworking Tips Online
- Woodworking Techniques — Step-by-Step
- Project plans you can download
- WoodNet Forum — Woodworkers' Q & A
- Power Tool Reviews

Point your browser to: <http://www.augusthome.com>  
 Select "Woodworking" from the Welcome Page menu.

## EDITOR'S NOTE

# Cutoffs

As a kid, one of my favorite toys was an erector set. I'd spend hours assembling the metal parts with tiny nuts and bolts. Tightening each connection with "real" wrenches.

But something else about it intrigued me even more — some of the parts actually *moved*. Gears meshed together perfectly. Pulleys guided heavy-duty steel cables (okay, it was only strong thread). There was even an electric motor that made it easy to forget that my steam shovel was just a toy.

While it's my son who's doing most of the building with the erector set these days, I still have that same fascination with moving parts. Which is why I'm excited about the projects in this issue. Each one depends on a unique system of moving parts to make it work.

**VISES.** For example, the small workbench featured on page 16 has two different vises that are made from "scratch." One opens and closes the *top* of the workbench. And the other uses a long, vertical arm that works like a giant lever to apply pressure.

Now you'd think that building your own vise would require a lot of complicated hardware. But that's not the case. Except for the handles (which we had to order by mail), each vise is made from parts we picked up at the local hardware store.

But why not just buy a store-bought vise and bolt it to the bench? First of all, it's considerably less expensive to make your own. But even more important, incorporating these shop-built vises into the design of the bench pro-

vides a number of different clamping options that many workbenches just don't have — regardless of their size.

**ASSEMBLY TABLE.** Moving parts are also the key to the assembly table on page 4. To hold most any size project at a comfortable working height, you can raise and lower the table. And to create a larger work surface, two extension wings flip up.

**TOOL TRAY.** There's one last project where a simple moving part makes all the difference.

It's a tool tray with a drop-down lid, see page 24.

**FIRST BOOK.** For years, people have asked me, "When is *ShopNotes* or *Woodsmith* going to publish a good woodworking book?"

I finally have an answer. It's just about ready.

About a year ago, Doug Hicks (a long-time editor here at August Home Publishing), started working on some book ideas. And just a couple of weeks ago he told me that the first book was about ready to go to the printer.

After looking at some of the early pages, I'm pretty excited about seeing the finished product. The first book (with more to come soon) is called *Bookcases and Shelves*, and it includes some of the best projects we've ever published. They're all done in our typical step-by-step, illustrated style.

Doug also found a special binding process that allows the book to open flat without flapping shut when you lay it on a bench. It's perfect for use in a shop.

The book should be ready for delivery by the holiday season. We're offering a special early discount for *ShopNotes* subscribers at \$17.95. If you'd like to order one, call 800-444-7002.

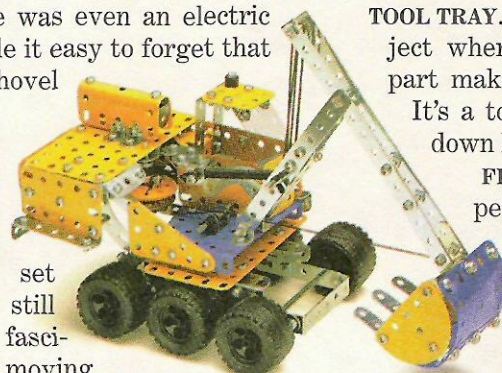

Tim

# Contents

## Projects

### Assembly Table \_\_\_\_\_ 4

No matter what size project you're building, this assembly table makes it easy to put it together. Raise or lower the table to hold projects at a comfortable working height. And flip up two wings to expand the work surface.

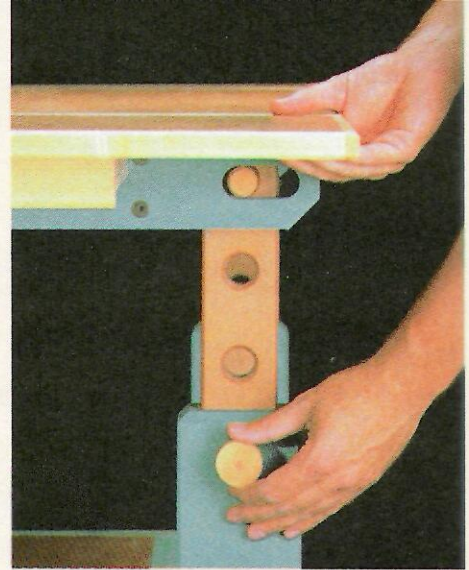

Assembly Table page 4

### Small Workbench \_\_\_\_\_ 16

Don't let its small size fool you. This sturdy workbench features two shop-made vises that provide more clamping options than many benches twice its size. There's even an optional cabinet for storing tools and supplies.

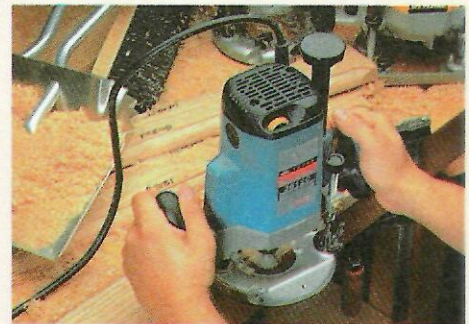

Plunge Routers page 10

### Drop-Down Tool Tray \_\_\_\_\_ 24

You can take advantage of the unused space under your bench with this handy tool tray. The lid drops down to provide quick access to your tools. And a set of unique tool holders keeps everything safely in place.

## Departments

### Selecting Tools

### Plunge Routers \_\_\_\_\_ 10

ShopNotes puts eight heavy-duty plunge routers to the test. Which one is best? And what are the key things to look for when you're buying a plunge router?

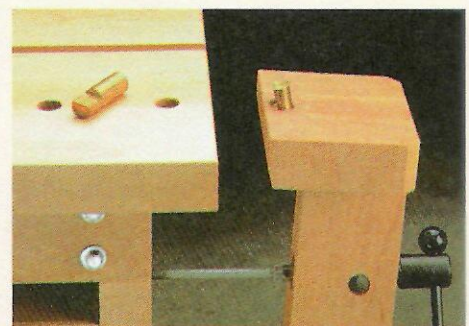

Small Workbench page 16

### Readers' Tips

### Shop Solutions \_\_\_\_\_ 28

Our readers offer their own shop-tested tips: Locking Tool Base, Band Saw Shelf, Box Joint Tip, a Shop-Vacuum Handle, plus three quick tips.

### Lumberyard

### Wood Moisture \_\_\_\_\_ 30

Using wood with the right moisture content can make or break a project. That's because the amount of moisture affects everything from the fit of the joints to the finish.

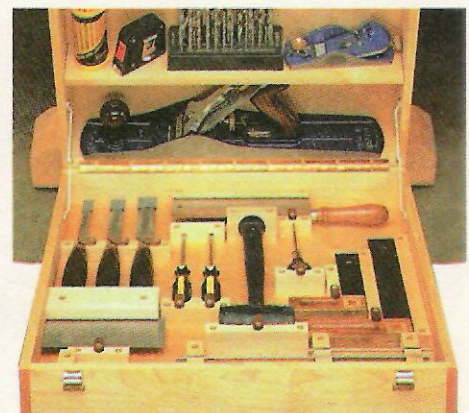

Tool Tray page 24

### Finish Room

### Spray Painting a Finish \_\_\_\_\_ 31

There's more to applying a spray-painted finish than just shaking up a can of paint. Especially if you want to produce a durable finish that looks good too.

# Assembly Table

*This assembly table has it all — a top that adjusts in height, an expandable work surface, plus room for storage.*

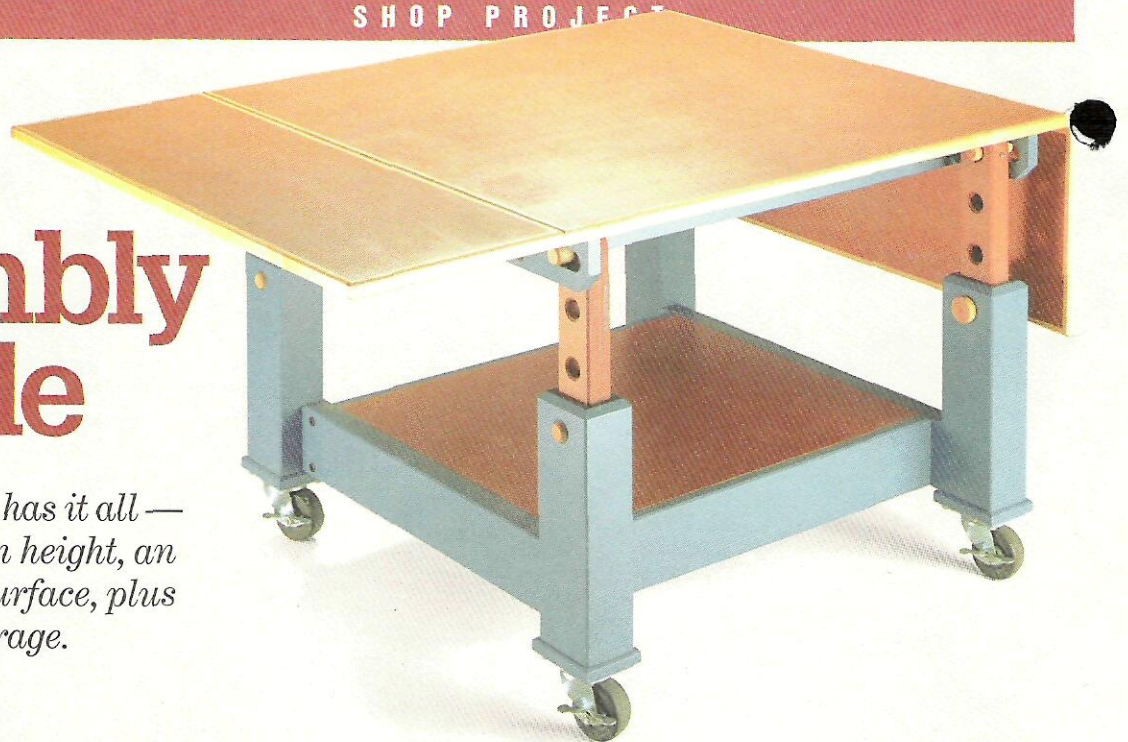

**W**hen it comes to assembling a project, it's hard to find just the right place. The top of my bench can be too high up off the floor (or too small) to handle some projects. And assembling a project on the floor is hard on my knees and back.

That's why I built this assembly table, see photo above. To hold a project at a comfortable working height, I just raise or lower the table. And for big projects, I can make the work surface larger.

**ADJUSTABLE HEIGHT.** To adjust the height of the assembly table, each leg has a post that slides inside a sleeve, see photo above. A series of holes in each post lets you raise the table up to 30", or lower it down to 21" off the floor.

The nice thing about adjusting the height of the

table is you don't need a helper to do it. That's because each end can be raised (or lowered) separately, see photos below left.

**WINGS.** And making the work surface bigger when assembling large projects is just as easy. That's because there's an extension wing that flips up on each side of the table. To hold the wings *and* the weight of the project, a sturdy support pulls out from underneath the table, see photos below right.

**STORAGE.** Another thing I like about this project is its storage shelf. It's a perfect place for glue, clamps, and parts that are going to be assembled, refer to the photos on the back cover.

**PAINT.** Finally, you can finish the table with spray paint as shown here. Or just apply several coats of oil.

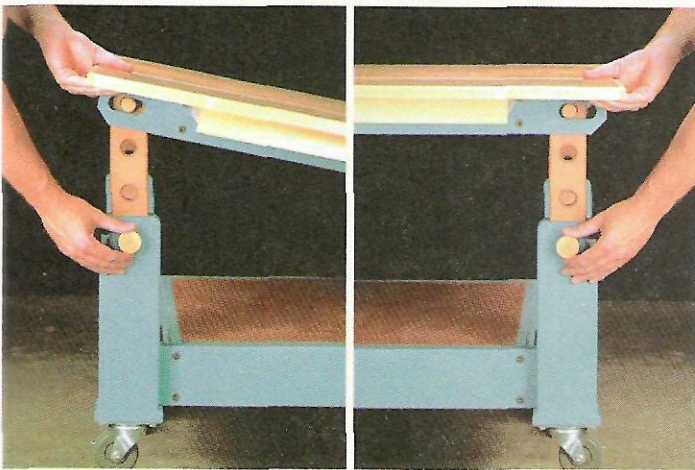

▲ **Adjustable Height.** It's easy for one person to adjust the height of the table. Lift one end and pin it in place (left). Then raise the other end and install the other pins (right).

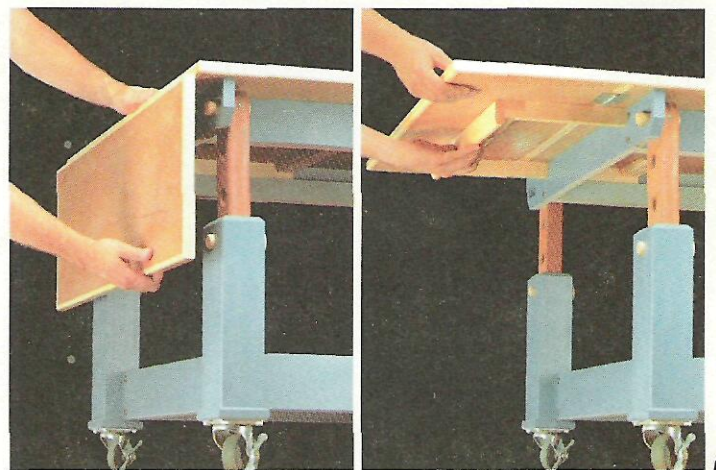

▲ **Expandable Work Surface.** An extension wing on each side of the table also lets you enlarge the work surface. Just raise the wing (left) and pull out a support (right).

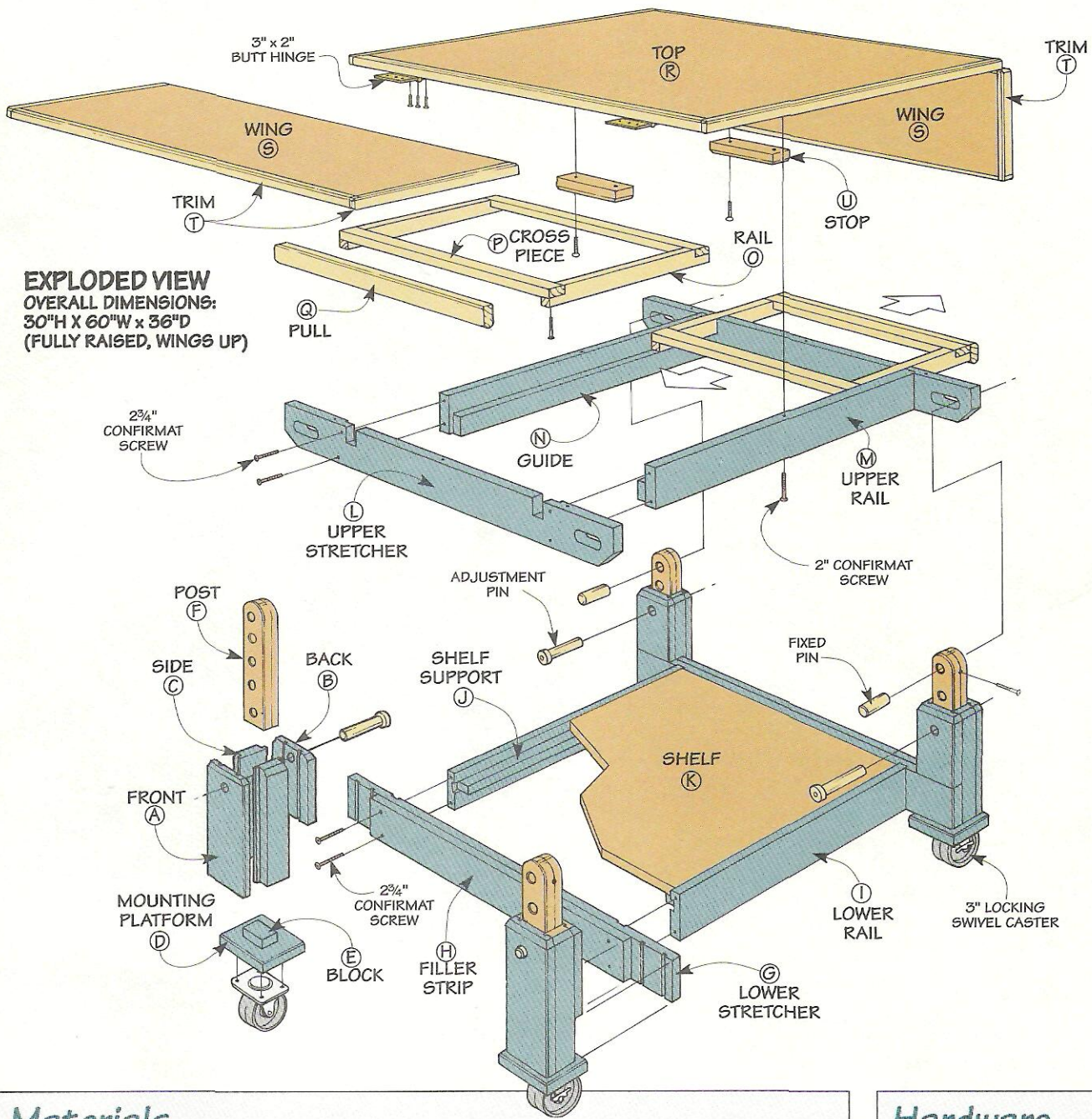

**EXPLODED VIEW**  
**OVERALL DIMENSIONS:**  
**30"H X 60"W x 36"D**  
**(FULLY RAISED, WINGS UP)**

**Materials**

**Base**

- A Fronts (4) 4 x 12 3/4 - 3/4 MDF
- B Backs (4) 4 x 8 3/4 - 3/4 MDF
- C Sides (8) 1 3/4 x 12 3/4 - 3/4 MDF
- D Mnt. Platforms (4) 3 1/2 x 4 1/2 - 3/4 MDF
- E Blocks (4) 1 1/2 x 2 1/2 - 3/4 MDF
- F Posts (8) 2 1/2 x 14 3/4 - 3/4 MDF
- G Lower Stretchers (2) 4 x 33 1/2 - 3/4 MDF
- H Filler Strips (2) 4 x 25 1/4 - 3/4 MDF
- I Lower Rails (2) 4 x 26 1/2 - 3/4 MDF
- J Shelf Supports (2) 1 x 26 - 3/4 MDF
- K Shelf (1) 22 1/4 x 26 - 3/4 MDF

**Top**

- L Upper Stretchers (2) 3 x 34 1/2 - 3/4 MDF
- M Upper Rails (2) 3 x 31 - 3/4 MDF
- N Guides (2) 1 3/4 x 30 1/2 - 3/4 MDF
- O Rails (4) 3/4 x 1 1/4 - 17
- P Cross Pieces (4) 3/4 x 1 1/16 - 22 1/4
- Q Pulls (2) 3/4 x 1 3/4 - 22 1/4
- R Top (1) 35 1/4 x 35 1/4 - 3/4 MDF
- S Wings (2) 11 1/4 x 35 1/4 - 3/4 MDF
- T Trim 3/4 x 3/8 - 30 ft.
- U Stops (2) 1 1/2 x 6 - 3/4 MDF

Note: You'll need 1 1/2 sheets of Medium-Density Fiberboard (MDF), approximately 4 bd. ft. of 3/4"-thick hardwood, 3 ft. of 1"-dia. dowel and 1 ft. of 1/4"-dia. dowel for this project.

**Hardware**

- (8) #8 x 1" Fh Woodscrews
- (4) #8 x 1 1/4" Fh Woodscrews
- (4) #8 x 2" Rh Woodscrews
- (8) 2" Confirmat Screws
- (16) 2 3/4" Confirmat Screws
- (16) 1/4" x 1" Lag Screws
- (4) 3" x 2" Butt Hinges (w/screws)
- (4) 3" Locking Swivel Casters
- (4) 1 1/2"-Dia. x 1/2"-Thick Wheels (with 1/4"-dia. hole)

For a complete hardware kit, call ShopNotes Project Supplies at 800-347-5105.

Kit No. 6830-100.....\$87.95

# Base

I started on the assembly table by making the base. It consists of four adjustable legs that let you raise and lower the table, and a frame that supports a storage shelf, see drawing at right.

## LEGS

To adjust the height of the assembly table, each leg is made of two parts: a hollow sleeve and a post that slides up and down. The post has a series of adjustment holes. Aligning one of these holes with a hole in the sleeve and inserting a pin sets the table to the desired height.

**MDF** To make it easy to raise and lower the table, it's important that the post slides smoothly without binding in the sleeve. So both parts are made from Medium-Density Fiberboard (MDF) which won't expand and contract with changes in humidity.

**SLEEVES.** I began work by making the four sleeves. Each one is just a box with a wide front (A) and back (B) piece and two narrow sides (C), see Fig. 1. Note: To create a recess for the stretcher that will be used to join the legs together, the back is

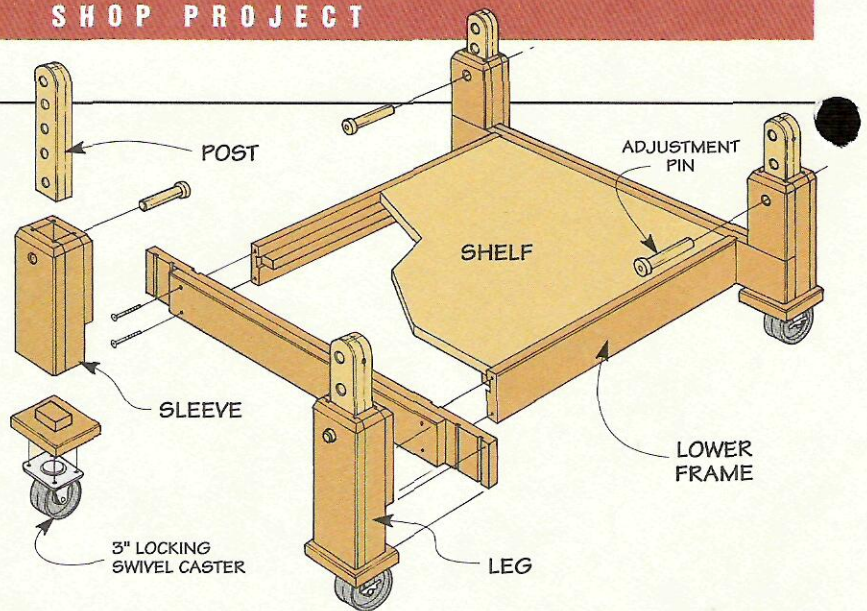

shorter than the front and sides.

The pieces of the sleeve are held together with tongue and groove joints, see Figs. 1 and 1a. Besides adding strength, this makes it easy to align the pieces so the size of the opening is consistent from top to bottom.

Before assembling the sleeve, you'll need to drill and chamfer the holes in the front and back for the adjustment pin (added later), see Fig. 1.

After gluing up the sleeve, I routed a  $\frac{3}{8}$ " chamfer on the top outside edges and an  $\frac{1}{8}$ " chamfer on all four corners, see Fig. 2.

All that's left to complete each

sleeve is to add a platform to the bottom for a caster. It's nothing more than two glued-up blocks. The caster will attach to the *mounting platform* (D), see Fig. 2 and drawing above. A small *block* (E) centers the platform in the sleeve when it's glued in place.

**POST.** With the sleeves complete, the next step is to add the four sliding *posts* (F), see Fig. 3. Each post starts out simply enough — just two pieces of MDF that are glued together.

Once the glue dries, there's a series of five holes drilled in each post, see Fig. 3. The upper hole will be used later to attach the

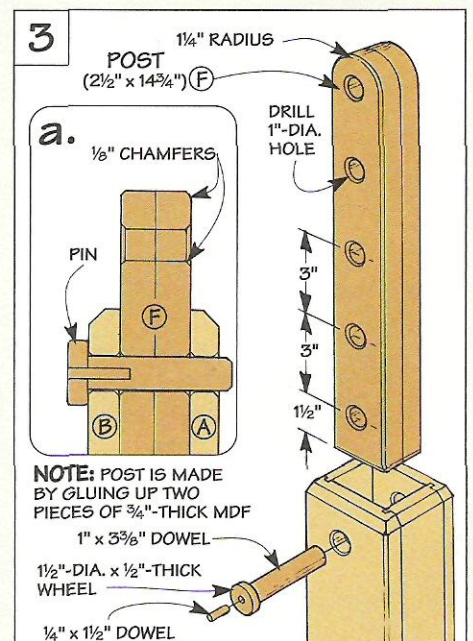
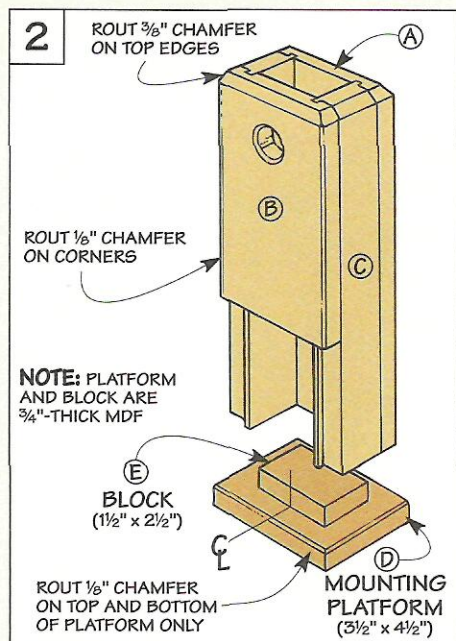
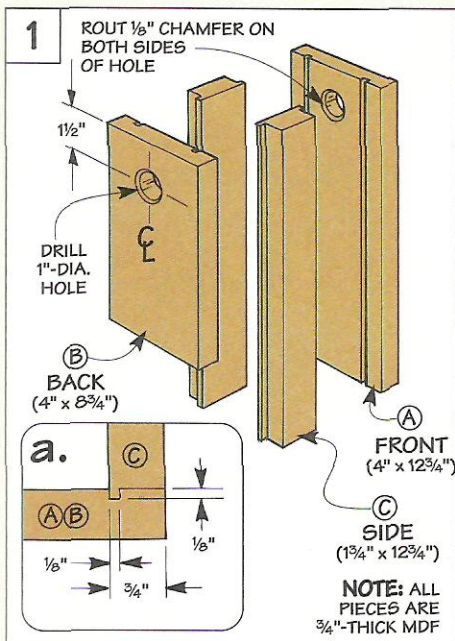

top assembly to the base. And the bottom four holes provide for the different height adjustments.

Since the table angles as you adjust the height (see photos on page 10), you'll need to cut a curve on the top of each post to provide clearance, see Fig. 3. Then rout small ( $\frac{1}{8}$ " chamfers on all the edges to keep the post from catching inside the sleeve.

PINS. Now all that's left is to add four pins to lock in the height adjustment. These pins are just 1"-dia. hardwood dowels (I used maple). A toy wood wheel that's held in place with a  $\frac{1}{4}$ "-dia. dowel makes it easy to remove the pin, see Figs. 3 and 3a.

**LOWER FRAME**

With the legs complete, you can add the lower frame that joins them together. What I found worked well was to connect the sleeves in pairs with parts of the frame, and then join the two assemblies together.

**STRETCHERS.** The first step is to connect each pair of legs with a *lower stretcher* (G), see Fig. 4. Two narrow kerfs cut in each end of the stretcher fit the exposed tongues on the sleeves, see Figs. 4 and 4a. And a dado accepts the rails (added later), see Fig. 4a.

To provide additional support, I cut a *filler strip* (H) to fit between the legs and glued it in place.

**RAILS.** At this point, it's just a matter of adding a pair of *lower rails* (I) to tie the two assemblies together, see Fig. 5. After cutting a groove for a *shelf support* (J) that's glued in place, I used a special fastener to attach the rails, see box at right.

**SHELF.** With the rails in place, you can add the *shelf* (K), see Fig. 5. It's a piece of MDF that's cut to fit the opening and set in place.

**CASTERS.** All that's left to complete the base is to attach a locking swivel caster to each platform with lag screws, see Fig. 5.

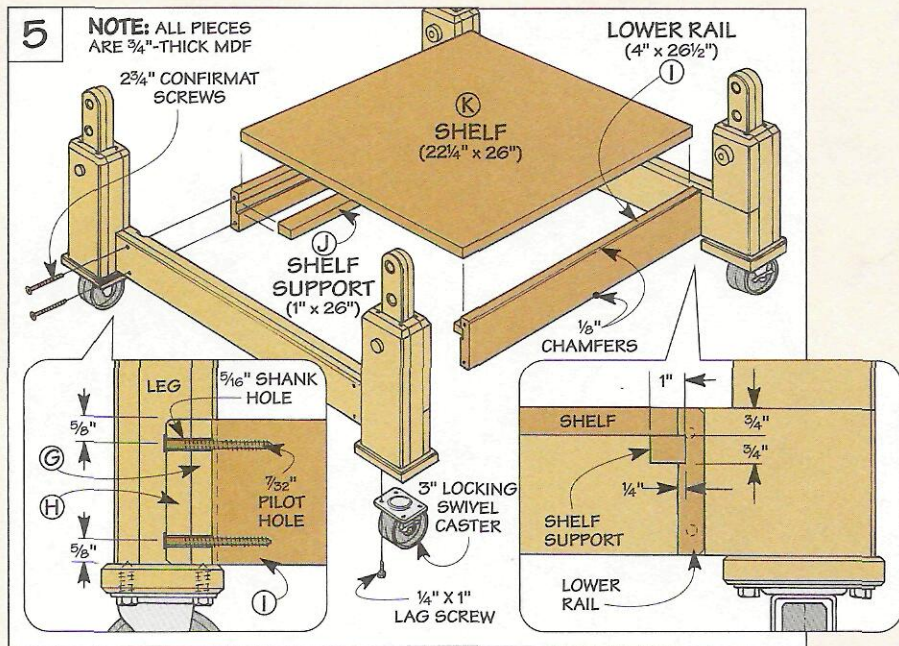
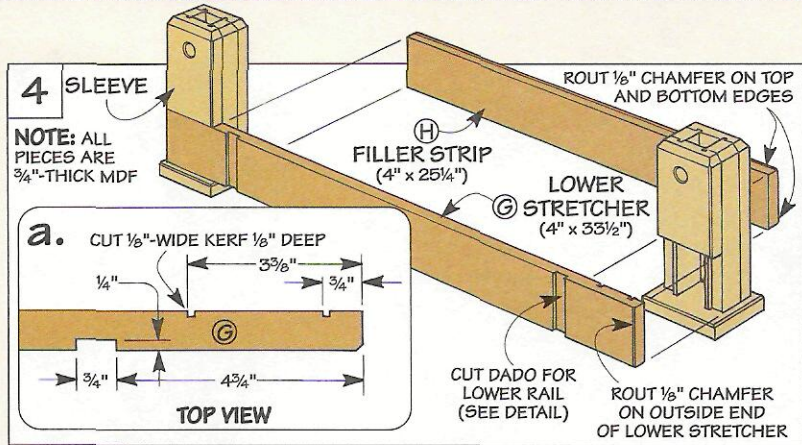

**Confirmat Screws**

One of the best fasteners I've found for working with Medium-Density Fiberboard (MDF) is a Confirmat screw, see photo at right. That's because it's specially designed to create a strong, mechanical joint.

**THREADS.** Take the threads for instance. They're deeper and spaced farther apart than the threads on a standard wood-

screw. This way, they won't pull out of the workpiece as easily.

**SHANK.** Besides the threads, the shank is also different. To keep from splitting the MDF, the shank is straight — not tapered like the shank on a woodscrew.

**HEAD.** One last thing about a Confirmat screw is the head is flat on the bottom. This keeps the head from pulling into the workpiece as you tighten it, see photo at left. (There's a recess in the head for an Allen wrench.)

Note: To order Confirmat screws, call Woodworker's Hardware (800-383-0130) or The Woodworkers' Store (800-279-4441).

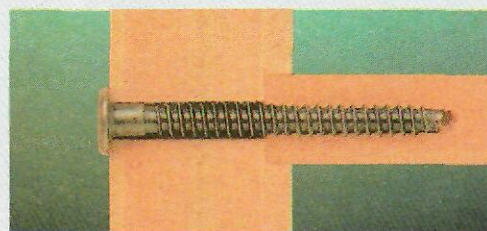

# Top Assembly

With the base complete, you can turn your attention to the top assembly. It consists of three main parts: an upper frame, a pair of wing supports, and a top and two wings, see the drawing at right.

## UPPER FRAME

Besides supporting the top, the upper frame houses the wing supports that slide out to hold up each wing.

**STRETCHERS.** The frame is attached to the base of the assembly table by two *upper stretchers* (L), see Fig. 6. It's held in place by a pin (added later) that passes through a slot

at the end of each stretcher; see Figs. 6a and 6b. These slots let you raise the frame without binding on the pin.

Also, to keep the stretchers from catching the sleeve of the leg as you raise the table, the bottom corners are cut at an

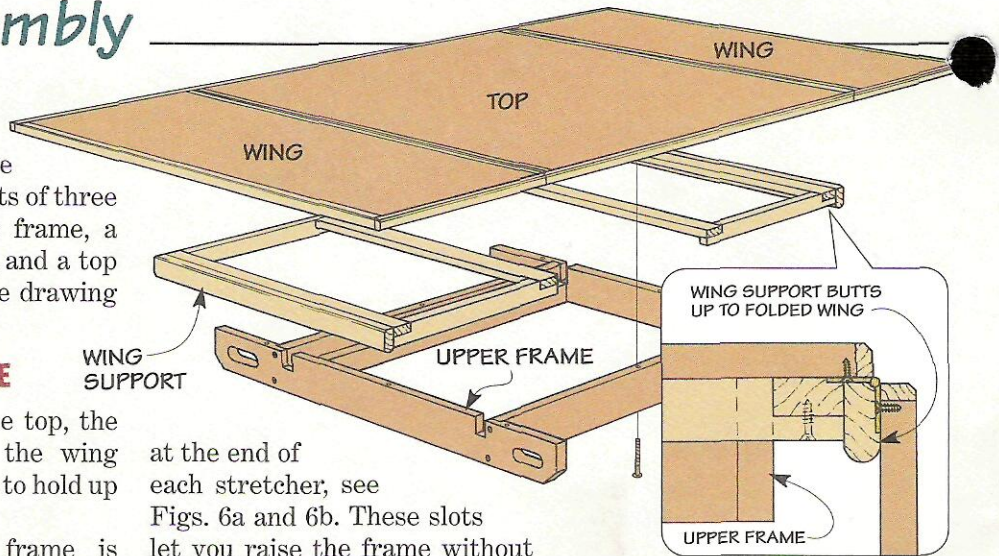

angle, see Fig. 6b.

To complete the stretchers, there's a dado cut near the end that will accept the upper rail. And cutting a wide ( $\frac{7}{8}$ " ) notch right next to the dado provides an opening that lets you pull out the wing support.

**RAILS.** The stretchers are connected by a pair of *upper rails* (M), see Fig. 6. To create a track for the wing supports to slide in and out, there's a *guide* (N) glued to the inside of each rail flush with the bottom of the notch.

Before assembling the upper frame there's one more thing to do. That's to drill counterbored shank holes in each stretcher and rail so you can attach the top later, see Figs. 6 and 6b.

**ASSEMBLY.** With the holes drilled, the upper frame is ready for assembly. Here again, I used Confirmat screws to attach the stretchers to the rails.

## WING SUPPORTS

With the frame complete, you can add the two wing supports. They're just small hardwood frames that slide in and out to support the wings.

Each frame is nothing more than a pair of *rails* (O) that are rabbeted at the ends to accept two *cross pieces* (P), see Figs. 7 and 7b.

After gluing and screwing the

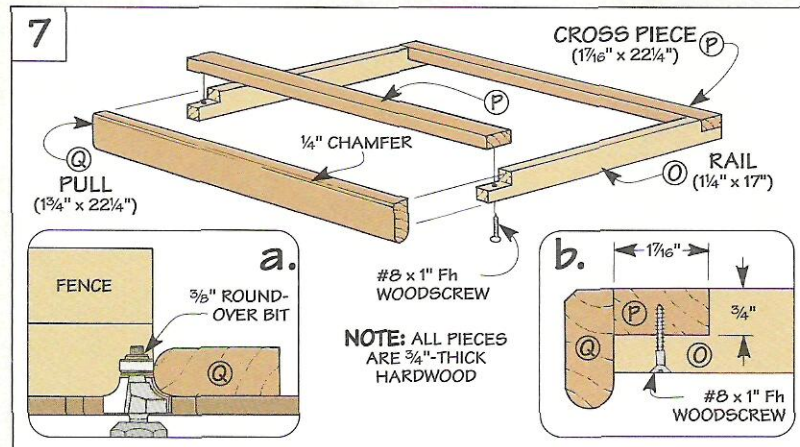
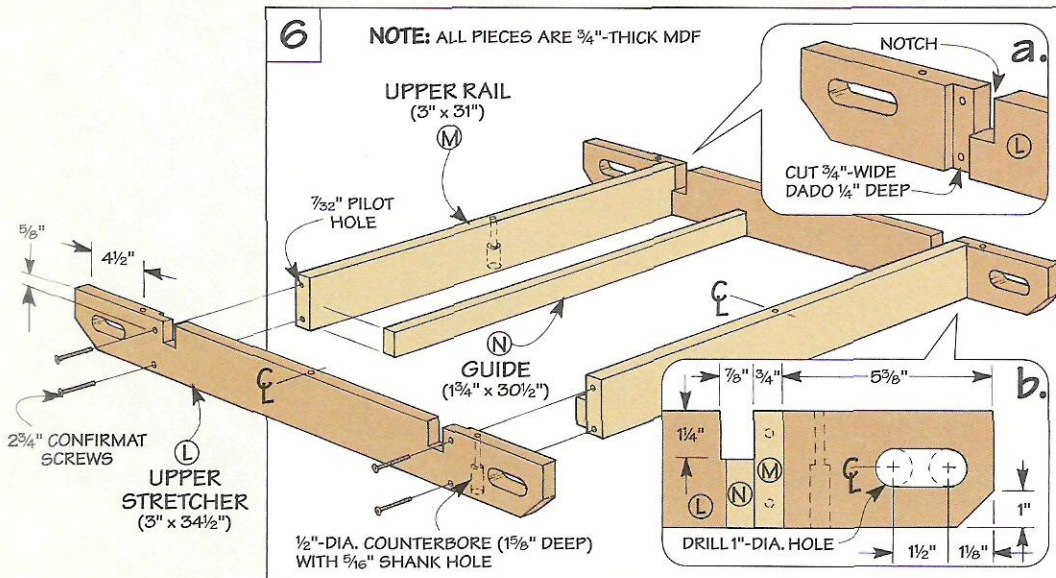



frames together, I added a hardwood *pull* (Q). To provide a comfortable grip, the bottom edges of the pull are rounded over, see Fig. 7a.

Finally, to prevent the wing from catching the edge of the pull as it's raised or lowered, I chamfered the top outside edge, see Figs. 7 and 7b.

**TOP & WINGS**

The main assembly area of the table is a large square top. But two rectangular wings increase the size of the work surface when working with large projects.

**PANELS.** The *top* (R) and *wings* (S) are 3/4"-thick MDF panels with hardwood *trim* pieces (T) "wrapped" around them, see Fig. 8.

After gluing on the trim, I chamfered all the edges except where the wings and top come together, see Figs. 8a and 8b. This way, there's a continuous surface when you install the hinges that hold the pieces together.

**ATTACH FRAME.** Once the top and wings are hinged together, you can attach the frame. It's easiest to start by flipping the top and wings upside down.

Then place the frame into position (centered on the top) and "capture" the wing supports in the notches of the stretchers, see Fig. 9.

Now just drill pilot holes in the top and attach the frame. Here again, it's held in place with Confirmat screws.

To avoid pulling the wing supports out too far, I screwed two simple *stops* (U) to the top, see Fig. 9.

All that's left is to flip the top assembly back over and attach it to the base. It's held in place with a pin (I used a dowel) that passes through the top hole of the post and into the slot in the stretcher, see Figs. 10 and 10a. Installing a screw "locks" the pin in place, see Fig. 10b.

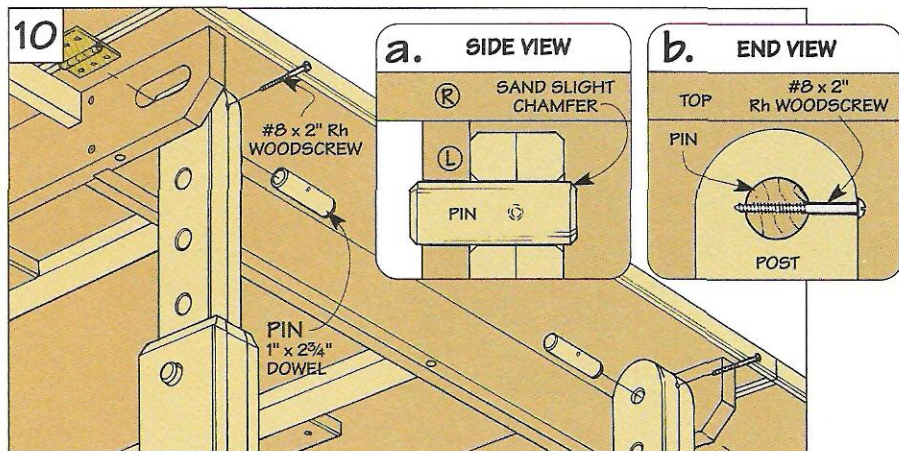
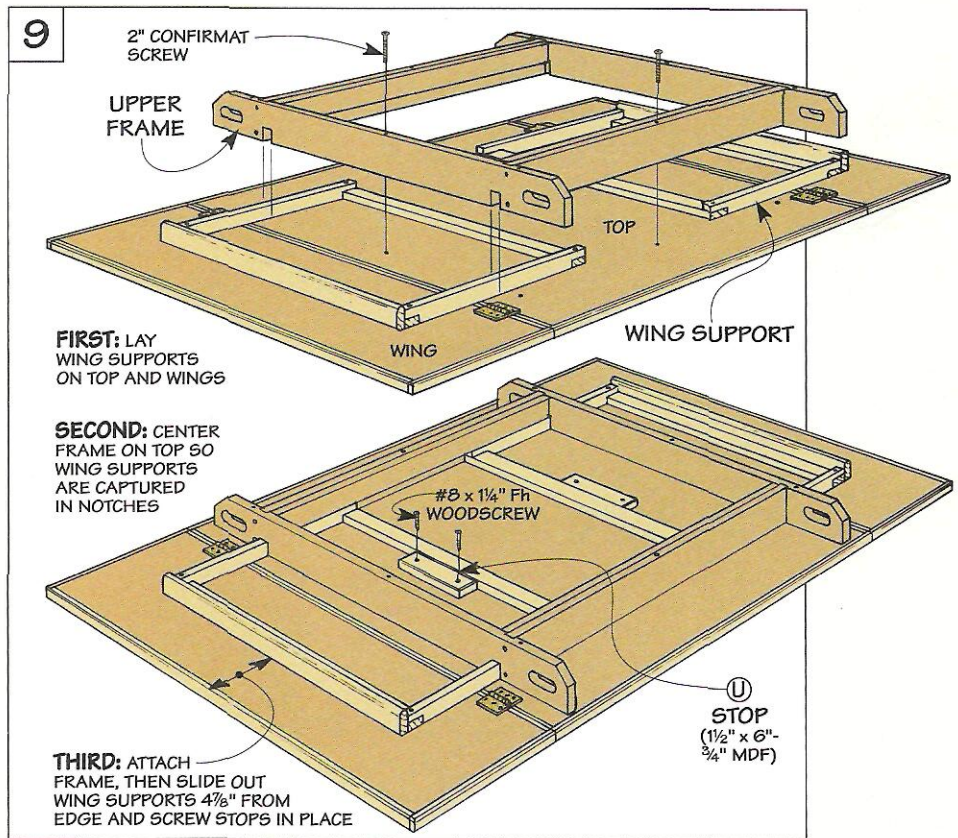
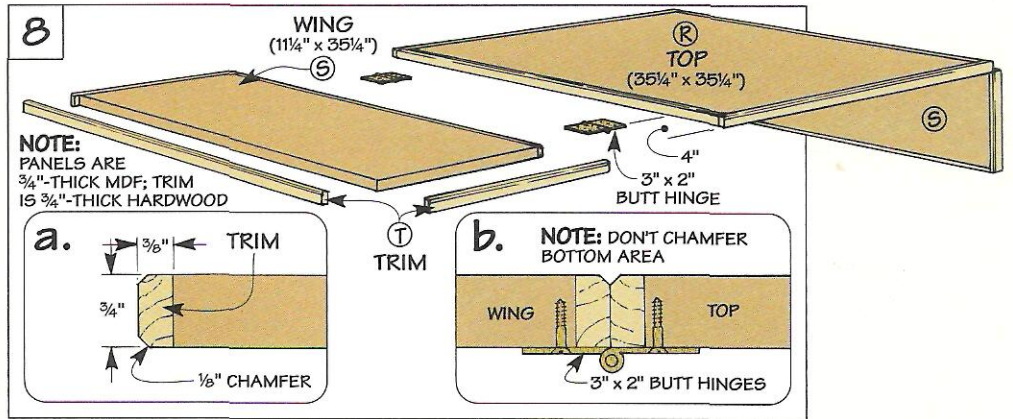

# Plunge Routers

*Thinking of buying a plunge router? We test eight heavy-duty models to help you select the one that's best for you.*

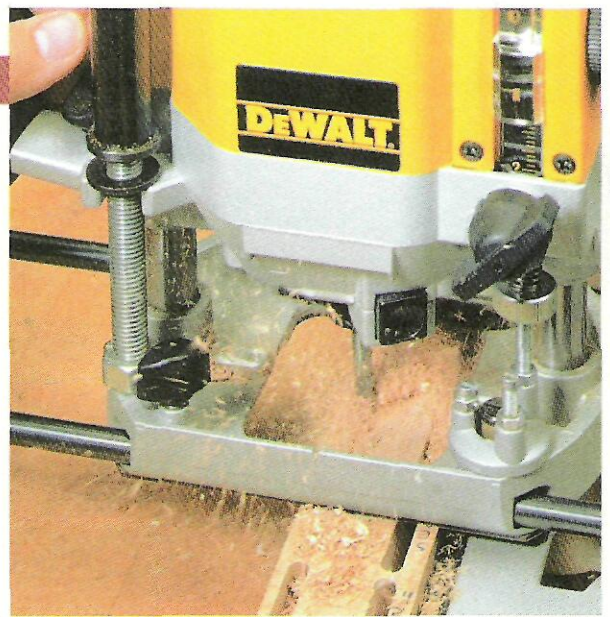

## How We Selected the Routers

Each router we tested has:

- Variable Speed Control
- a 1/2" Collet
- a 3-3/4 HP Motor
- costs between \$210 - \$295

I always used to think of a plunge router as a tool that was extremely specialized. One you'd expect to see in a big, commercial woodworking shop.

But a few years back, something happened that changed the way I looked at plunge routers — we got one for our own shop.

At first, we used it mainly for making the plunge-type cuts that it's designed for (like routing mortises or cutting stopped dados). But it wasn't long before we started using the new plunge router more and more in place of our old conventional router.

For example, it's not unusual to see one of the guys using it in a hand-held position for some-

thing as simple as routing a profile on the edge of a big project like a table. But its real "home" is mounted in the router table where it handles all kinds of jobs — from routing an 1/8" roundover to making raised panels.

**NEW BATCH.** Today, there's a whole new batch of plunge routers on the market. Some with bigger motors (and price tags). And most with enough switches, levers, and buttons to make selecting a plunge router just a bit confusing.

To help make this decision easier, we bought and tested eight plunge routers to find out which one is best. (See margin and photos below and on next page.)

Like our other tool tests we

rounded up three woodworkers with different amounts of experience. Both *Ken* (a professional cabinetmaker) and *Steve* (an advanced woodworker) use plunge routers extensively. And *Cary* (who is just getting started in woodworking) has a conventional router for his shop.

**Q:** So Cary, how do you like these plunge routers compared to the one you're using?

**Cary:** Since these routers have big motors and the plunge operation was new to me, I was worried about making a controlled cut.

But I was surprised at how easy it was. When I flipped the switch on, the bit accelerated up to speed



**Bosch 1615EVs**  
312-286-7330  
\$295.00

**DeWalt DW625**  
800-433-9258  
\$279.95

**Freud FT2000E**  
910-434-3171  
\$209.95

**Hitachi M12V**  
800-546-1666  
\$244.95

## Weight

<b>Bosch</b>	<b>14lbs/1oz</b>
<b>DeWalt</b>	<b>13lbs/10oz</b>
<b>Freud</b>	<b>11lbs/13oz</b>
<b>Hitachi</b>	<b>13lbs/1oz</b>
<b>Makita</b>	<b>13lbs/14oz</b>
<b>Porter Cable</b>	<b>17lbs/9oz</b>
<b>Ryobi</b>	<b>14lbs/10oz</b>
<b>Sears</b>	<b>12lbs/12oz</b>

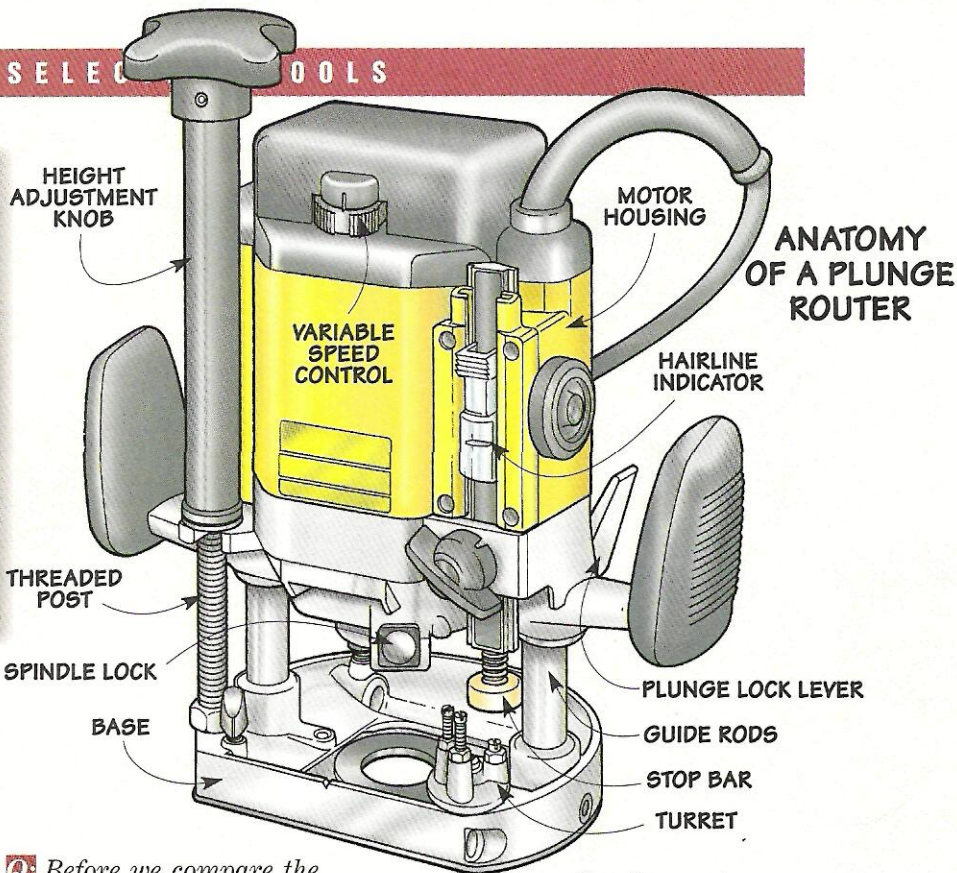

gradually. So the router didn't jerk to a start like I expected.

And lowering the bit into the workpiece was a snap. All it took was a little pressure on the handles to push the motor down the guide rods. (See drawing.) Once the bit was at the right depth, it was just a short reach to a lever to lock it in place — which let me concentrate on the job at hand.

I was also concerned about safely raising the bit out of the workpiece. But since the guide rods are spring-loaded, that wasn't a problem. When I release the plunge lock lever and ease up on the handles, the motor travels up the guide rods and retracts the bit safely above the workpiece.

**Q:** Before we compare the actual plunge operation, is there anything else you noticed?

**Steve:** One thing is the difference in weight. The Porter Cable is quite a bit heavier than the other routers. (See chart above.) So it could be a bear to lug around, or lift in and out of a router table.

**Ken:** Another minor thing is the Ryobi, Makita, Porter Cable, and Sears all have a round base instead of the D-shaped base like

the other routers.

So when I'm routing dadoes or grooves with a guide clamped to my workpiece, I have to mark a point on the base and keep it against the guide. This way, the bit will cut a consistent distance from the guide — even if it's not centered on the base of the router.

**Steve:** That's what I like about using the straight edge of a D-shaped base, it *always* keeps the bit at a consistent distance.



**Makita 3612C**  
800-462-5482  
\$269.95

**Porter Cable 7539**  
800-487-8665  
\$295.00

**Ryobi RE-600K**  
800-525-2579  
\$239.95

**Sears 27506**  
800-290-1245  
\$249.99

# Performance



**Mortises.** To test plunge operation for smoothness and accuracy, we routed a series of mortises.

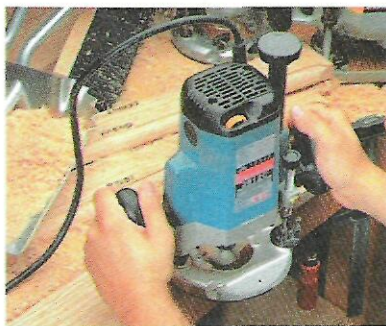

**Profile.** Routing a simple profile gave us an idea of the overall feel of the router in a hand-held position.

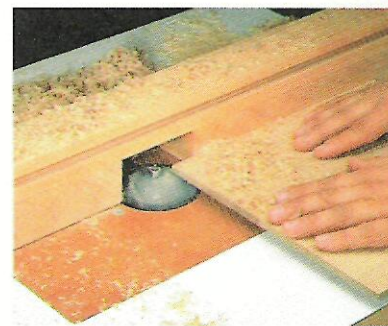

**Raised Panels.** To see how the routers perform when mounted in a table, we routed raised panels.



**Turrets.** The “stops” on the turrets that establish the depth of cut can either be fixed (top) or adjustable (bottom). Both types work equally well.

**Q:** When it comes to performance, what’s the key thing you’re looking for in these plunge routers?

**Ken:** That’s easy. The plunge operation has to be smooth and accurate.

That’s why I liked the DeWalt. The motor travels up and down the guide rods like a hydraulic ram.

Not only that, there’s no side to side play. So if I’m doing some intricate work (like routing a recess for a piece of inlay), I’ve got pinpoint control.

**Steve:** The Makita, Hitachi, and Porter Cable may not be as smooth as the DeWalt. But they all feel like precision-made tools to

me. Especially compared to the Ryobi, Freud, Bosch, and Sears. These all have a little more “play” when I’m making a plunge cut.

**Ken:** Another thing that affects the plunge operation is the springs in the guide rods. They have to be strong enough to raise the motor and retract the bit above the workpiece at the end of a cut. But not so strong that there’s resistance when I plunge the router.

On all the routers except for two, the springs were up to the job. But with the Hitachi and Ryobi, I had to give them a boost — usually after I’d completed a deep cut.

**Q:** Did you have any trouble setting the depth of cut?

**Cary:** The whole process was considerably easier on the DeWalt, Hitachi, and Porter Cable. That’s because I can set the depth adjustment system on each one to zero. (See drawings below.) Once it’s “zeroed out,” I just set the stop bar to 1” on the scale if I want a 1” depth of cut.

But I can’t do that with the Bosch, Sears, and Freud. That’s because there’s no way to “zero out” the system. So I have to use some other number as a reference. And that means doing some arithmetic. I have to add (or subtract)

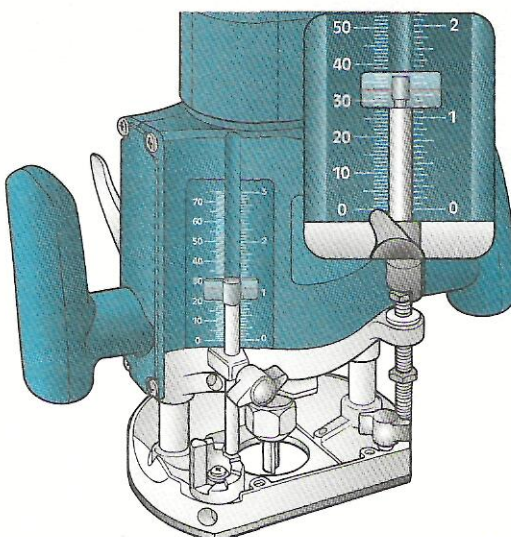
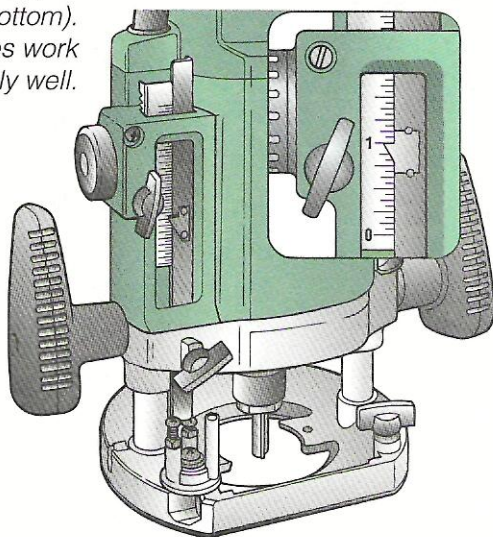

**Depth of Cut.** The depth adjustment system on the left can be set to zero. So the scale indicates the actual depth of cut (1”). But the scale won’t indicate the exact depth of cut on a system that can’t be “zeroed out” (right).

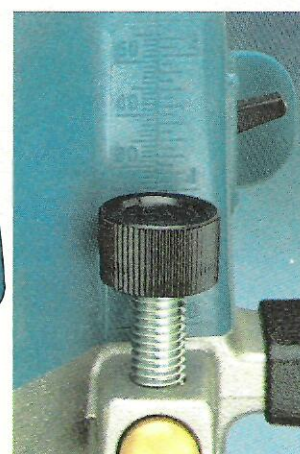

**Scales.** The depth of cut scale on the Makita (shown here) and the Ryobi are hard to read. And there’s no hairline indicator for setting the depth of cut accurately.

the depth of cut from whatever the reference number happens to be. And that leaves room for error.

**Ken:** Even so, those depth adjustment systems are better than the ones on the Ryobi and Makita. These can't be "zeroed out." And unlike the rest of the routers, there's no hairline indicator. (See bottom photo on page 12.) So it's hard to read the scales accurately.

**Q:** What about the plunge lock mechanisms? Are some easier to use than others?

**Cary:** The locking mechanism on the Sears is probably the most convenient. I just squeeze a switch that's built into the handle. (See photos above.)

**Steve:** The other routers all use a lever. Since they're just a short reach from the handle, they're easy to use too.

The only levers that are a bit odd are the ones on the Porter Cable and Bosch. These levers are spring-loaded in the "lock" position. So I can't even plunge the router without unlocking the lever first. That gets to be a pain.

**Ken:** It also causes problems when you mount these routers in a table. It takes *two* hands to adjust the height of the bit — one to unlock the lever, and the other to adjust the depth of cut.

**Steve:** Besides the lever, there's something else going on

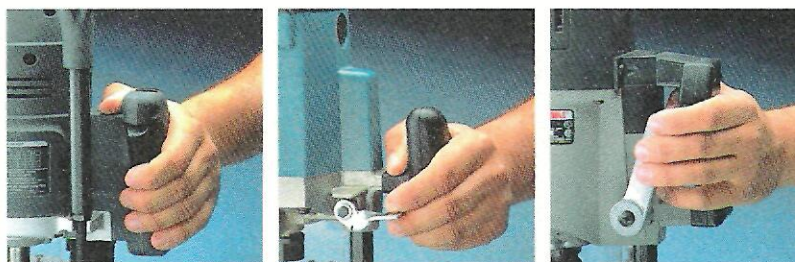

**Plunge Lock.** The plunge lock switch on the Sears (left) and the lever on the Makita (center) are easy to use. But you have to unlock the lever on the Porter Cable (right) to make a cut — and that's a nuisance.

with the Bosch when it's mounted in a router table. It jams on the guide rods after just a few turns of the height adjustment knob. So it's flat out impossible to use in a router table.

**Q:** Were there any differences in the variable speed controls on these routers?

**Ken:** The biggest thing is the Porter Cable has five separate speeds instead of a continuous range like the other routers. (See chart.) There's nothing wrong with that. But what happens is the speed of the Porter Cable fluctuates when I start a cut. The other routers run at a more constant speed.

**Steve:** Regardless of the type of speed control, each router has that nice "soft start" that Cary was talking about earlier.

**Cary:** The only thing that's different is the on/off switches. The Porter Cable, Sears, and Bosch

have a trigger switch in the handle. (See margin.) So if something unexpected happens, I just release the trigger to shut off the router.

It's not quite as automatic with the toggle switches on the Ryobi and Makita. Or the slide switches on the Hitachi, Freud, and DeWalt.

**Steve:** One thing about the Makita though is that when you turn it off, an electric brake stops the bit on a dime. That's a nice safety feature. And it's the only router that has it.

**Q:** Anything worth mentioning about the handles?

**Ken:** I like to be able to shift my grip to suit the job. So I liked the adjustable handle on the Hitachi. (See photos below.)

The only uncomfortable handles were the ones on the Porter Cable. Unlike all the others, they're attached in two places, so I feel like I'm handcuffed.



**Switches.** A trigger switch that's built into the handle (top) is handier to use than a toggle switch (center) or a slide switch (bottom).

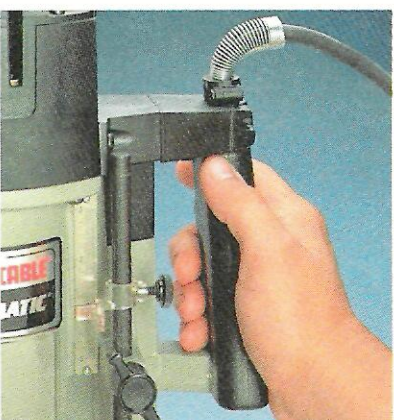

**Handles.** The handle on the Hitachi (left) adjusts to provide a comfortable grip. And it's attached in just one place. So it doesn't "trap" your hands like the dual supports on the handle of the Porter Cable (right).

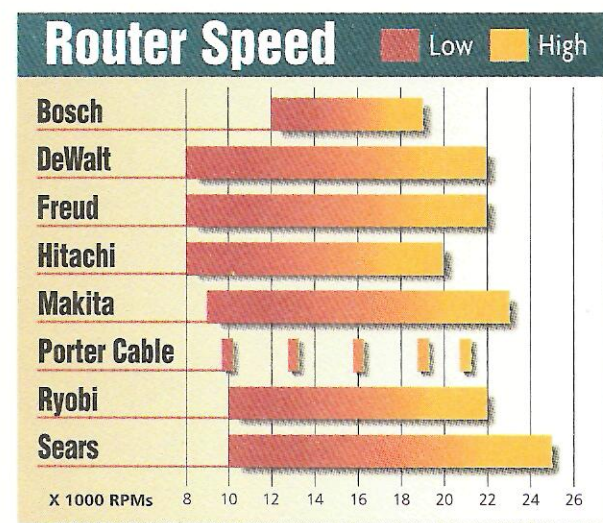

# Changing Bits

**Q:** By now, you guys must have changed more than your fair share of router bits. Do any of these routers make that job any easier?

**Cary:** Yes, the ones where I can lock the spindle while I loosen the bit. That way, I only have to use (and keep track of) one wrench instead of two.

**Steve:** A spindle lock is pretty much standard on these routers. The only router that doesn't have one is the Porter Cable.

**Ken:** I especially liked the spindle lock on the Sears. It's just a bar that slides from one side to the other. (See photos above.) What's nice about it is I can let go of the bar and use both hands to change bits.

But since all the other spindle locks are spring-loaded, I have to push them in with one hand while I loosen the bit with the other.

**Cary:** As long as we're talking about changing bits, I should mention the wrenches. The Makita,

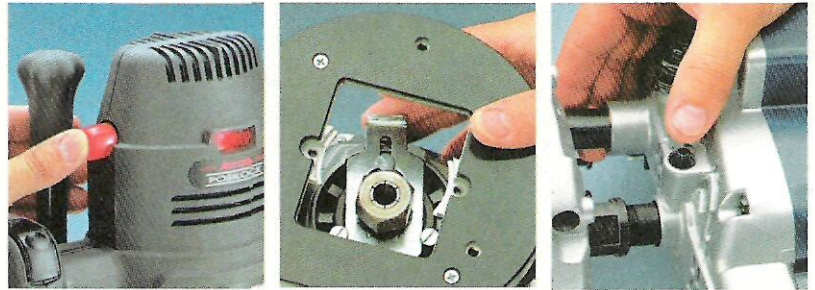

**Spindle Locks.** A sliding bar on the Sears (left) locks the spindle and leaves both hands free to change bits. So it's more convenient than a spring-loaded "wrench" (center) or button (right).

DeWalt, and Ryobi have cast wrenches that have a nice heft to them. (See photos below.) All the other wrenches are made from lightweight stamped steel.



**Q:** Let's talk about the thing that can make or break a router — the collet. How do the collets on these routers stack up?

**Ken:** I never had a single bit slip during the test. So I'd say

the collets are doing their job. Even so, each of the routers goes about it in a different way.

Most of the routers (all except the Hitachi and Sears) use a collet and nut assembly. (See drawings below.) Slits in the collet form "fingers" that apply pressure to the bit as you tighten the nut. In theory, the more slits, the more even the pressure.

But the collet on the Hitachi only has three slits. And it grips the bit like a barnacle. The only thing about this collet is it tightens after about a quarter of a turn. And I was never quite sure if I'd tightened it enough.

**Steve:** The collet on the Sears is completely different. It's actually part of the motor shaft. That sounds like a nice idea — one less part to keep track of. But if it gets damaged (or wears out), I'd have to replace the whole shaft.

**Cary:** What mattered more to me than the design of the collets was whether I could still use the 1/4" router bits I already have.

**Steve:** That's pretty easy with the DeWalt, Porter Cable, and Bosch. They provide a separate 1/4" collet. (See margin.) All the other routers use a sleeve that slips into the 1/2" collet and accepts a 1/4" bit.

I used to think that the sleeves wouldn't grip the bit as tight. But I've used a lot of them and never had a problem.



To use a 1/4" bit, some routers provide a separate 1/4" collet (left). But a sleeve that slips into the 1/2" collet (right) works just as well.

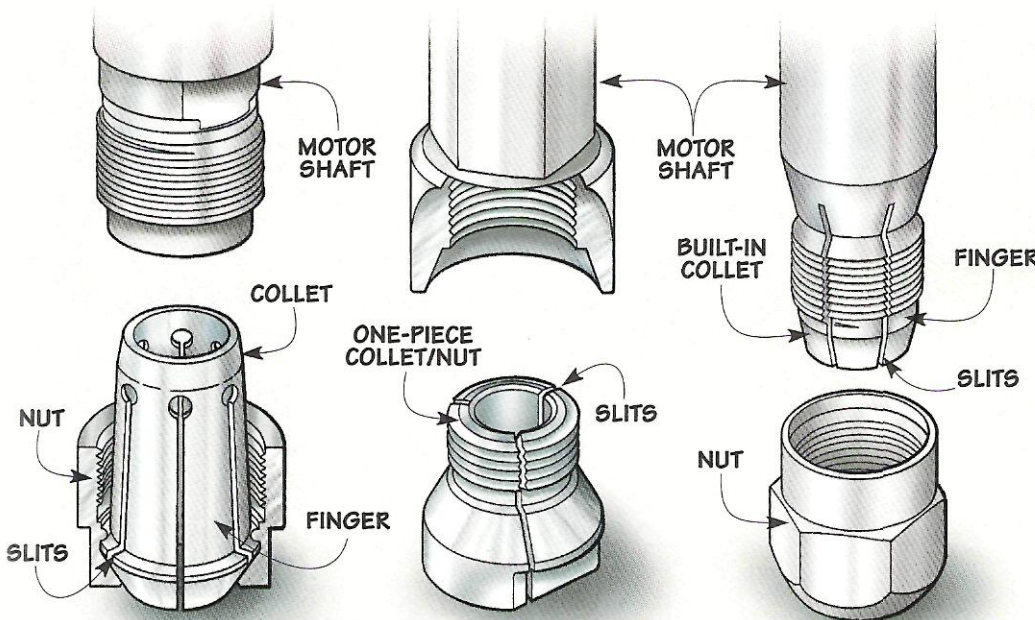

**Collets.** The collet and nut assembly on the DeWalt (left) and the one-piece collet on the Hitachi (center) both hold bits securely. And they're both easy to replace if they wear out or get damaged. But since the collet on the Sears (right) is part of the motor shaft, it would be expensive to repair.

# Accessories

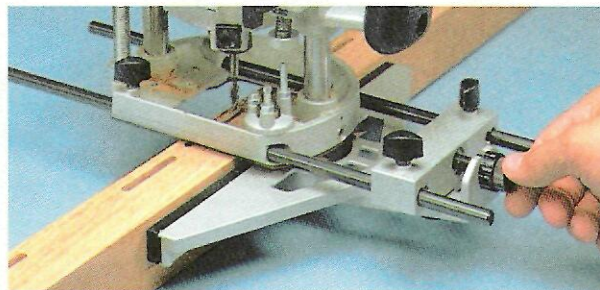
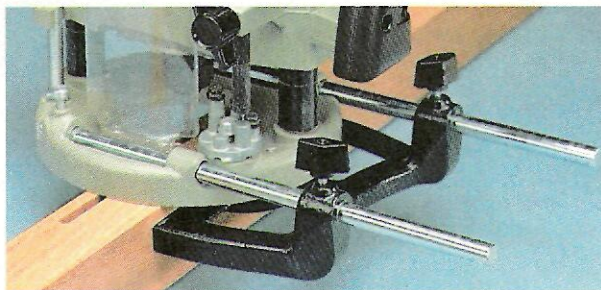

**Edge Guides.** The edge guide for the Porter Cable (left) doesn't have a micro-adjustable knob to "fine tune" the exact position of the bit. So it's not as handy as the micro-

adjustable edge guides on all the other routers. The DeWalt edge guide (right) is the most expensive. But its quality castings and smooth action are worth the cost.

**Q:** Just a few accessories add a lot to a router. So what's first?

**Ken:** I can't see buying a plunge router without getting an edge guide too. When I'm routing mortises or dadoes, it's a must for getting accurate results.

What I like about all the edge guides except the Porter Cable is I can fine tune the position of the bit. But with the Porter Cable, I have to "bump" the router to position the bit. (See photos above.)

**Steve:** There's another accessory that's important for me. Since my router spends a lot of its time mounted in a table, I'd want a height adjustment knob to make it easy to adjust the bit.

These knobs all work about the same. They fit onto a threaded post on the router so I can tweak the bit up or down. But the knobs on the Sears, Hitachi, Ryobi, and Freud get in the way of either the motor housing or power cord. So they're a bit

more difficult to use.

**Cary:** One last thing. I've done some routing using templates. So I've already got a set of universal guide bushings to run against the edge of the templates.

What's nice is I can use these bushings with the DeWalt, Porter Cable, and Hitachi without buying anything else. But with the Freud, Makita, Bosch, and Ryobi, I have to buy an adapter plate. The bad part about the Sears is I can only use their bushings.



**Guide Bushings.** Unlike the Sears (top) which comes with a single guide bushing, the DeWalt (center) has an adapter for a universal set. The Hitachi (bottom) comes with both.

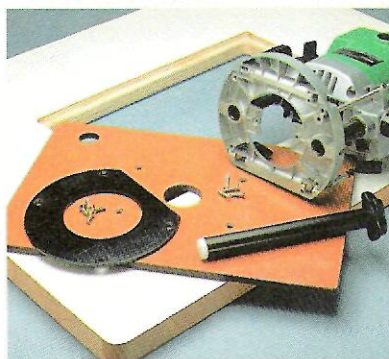

▲ A height adjustment knob, an insert and some screws are all it takes to mount a router in a table.

## Router Accessories

STD indicates accessory included

Plunge Router	Tool Price	Edge Guide	Adjustment Knob	1/4" Collet	Total Price Paid
<b>Freud</b>	\$209.95	STD	STD	STD	<b>\$209.95</b>
<b>Ryobi</b>	\$239.95	STD	STD	STD	<b>\$239.95</b>
<b>Sears</b>	\$249.95	STD	STD	STD	<b>\$249.95</b>
<b>Hitachi</b>	\$244.95	STD	\$12.99	STD	<b>\$257.94</b>
<b>Makita</b>	\$269.95	\$34.95	STD	STD	<b>\$304.90</b>
<b>Bosch</b>	\$295.00	\$32.95	STD	STD	<b>\$327.95</b>
<b>Porter Cable</b>	\$295.00	\$24.10	\$19.99	\$9.99	<b>\$349.08</b>
<b>DeWalt</b>	\$279.95	\$49.95	\$22.95	STD	<b>\$352.85</b>

## Recommendations

**Ken:** Picking just one router is tough. But I chose the DeWalt because it feels like a quality tool.

That quality shows up mainly in its incredibly smooth plunge action. Combine that with two-precision-made collets and an extremely accurate depth adjustment system, and it's hard to beat.

**Steve:** I chose the Makita. It's a compact router that performs like a solid, heavy-duty tool.

The plunge action is smooth and accurate. And I especially like the electric brake as an added safety feature.

All it needs is a better depth adjustment system.

**Cary:** I'd buy the Hitachi. It's not as expensive as the routers you guys picked. Yet it gives me a lot for my money.

I like its smooth plunge operation and easy-to-use depth adjustment system. And it comes with all the accessories I need except the height adjustment knob. 🛠️

# Small Workbench

*Don't be fooled by the small size of this workbench. It's sturdy. And it provides more clamping options than many benches twice its size.*

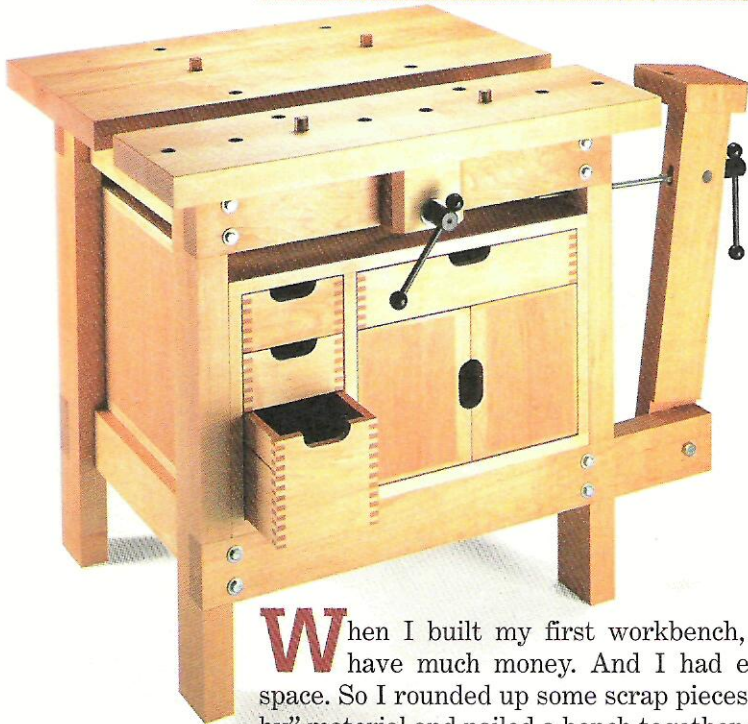

**W**hen I built my first workbench, I didn't have much money. And I had even less space. So I rounded up some scrap pieces of "two-by" material and nailed a bench together that was no bigger than a card table.

But in spite of the small size of the bench, there was still something about it I liked. With the bench tucked into the basement between the laundry area and shelves filled with fruit jars, I'd while away the hours — building a small box, getting a dovetail joint just right, or tuning up an old hand plane.

Well, it's funny how things work out. That bench has come full circle. In fact, it's the idea behind the small workbench shown in the photo above. The size is about the same as I remember it. Just right

for a small shop. Or even an out-of-the-way corner of your house. Only this time around, there are a few improvements.

**VICES.** For instance, this workbench has two vises: a *front vise* and an *end vise*, see photos below. Not your ordinary store-bought vises that are added onto the workbench after it's done. Instead, these vises are built *into* the bench.

By making each vise an integral part of the bench, you get a wide range of clamping options — more than many benches that are twice its size.

**STORAGE.** Besides the vises, this workbench has another advantage over my old bench — it has lots of storage. A cabinet fits inside the base of the bench and keeps tools and materials in easy reach.

## FRONT VISE.

The solid benchtop doubles as the front vise. With the two parts of the benchtop serving as the "jaws" of the vise, you can clamp work on edge (left). Or use bench dogs to hold irregular-shaped objects (right).

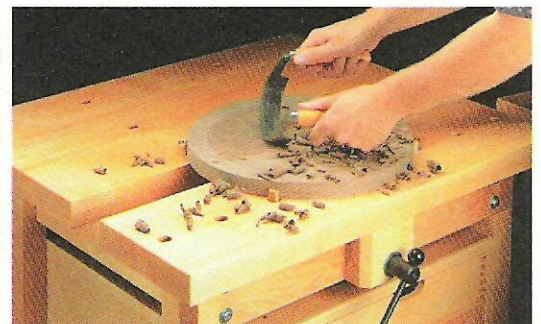
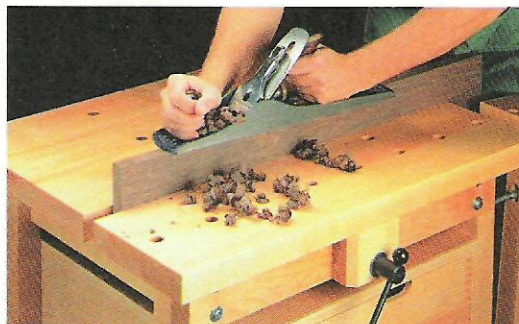

## END VISE.

To provide more clamping options, this workbench also features an end vise. Secure your work between the vise and the benchtop (left). Or add a pair of bench dogs to hold it flat against the benchtop (right).





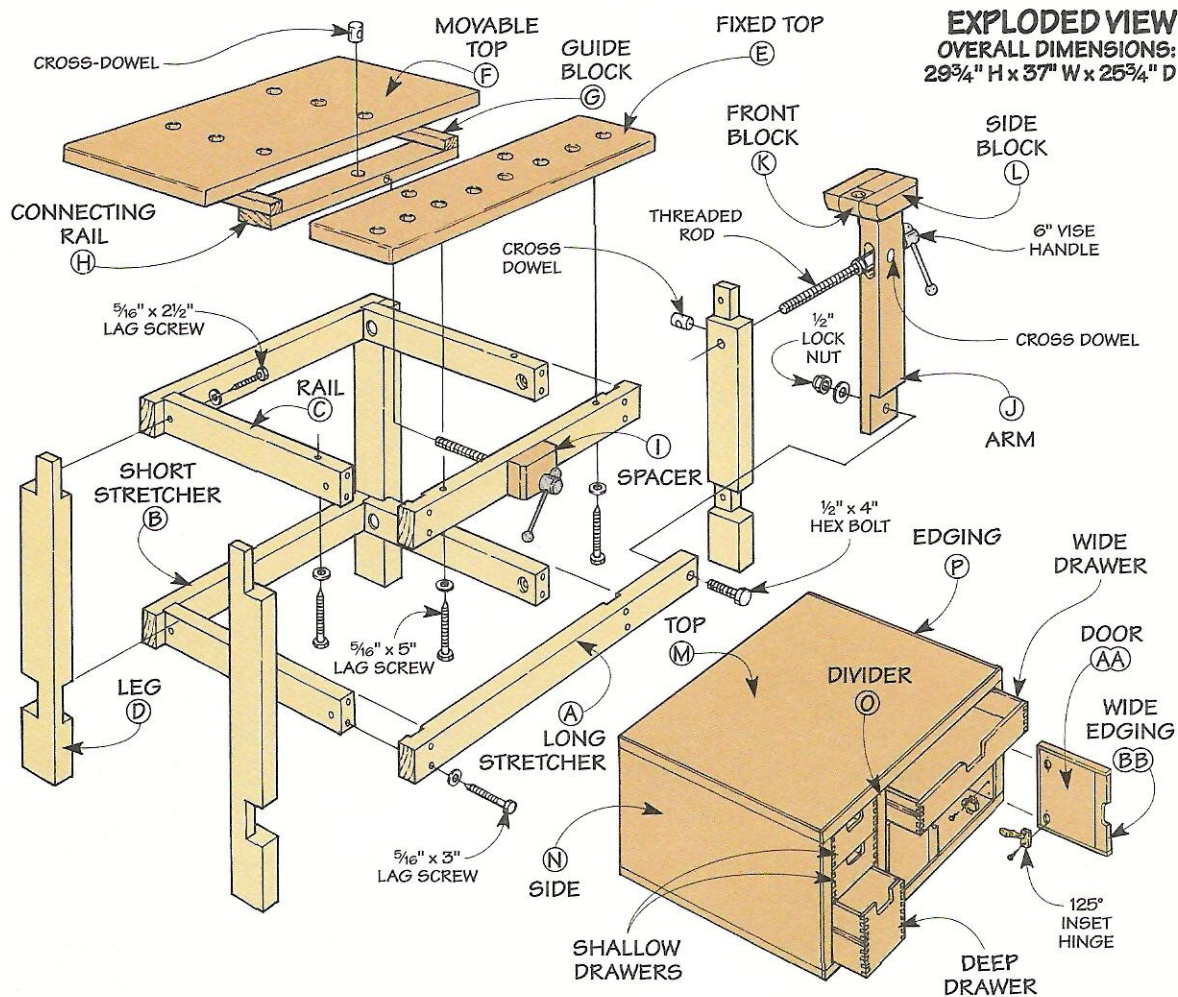

**EXPLODED VIEW**  
**OVERALL DIMENSIONS:**  
 29 3/4" H x 37" W x 25 3/4" D

## Materials

### Bench

A Long Stretcher (1)	1 3/4 x 3 1/2 - 33
B Short Stretchers (3)	1 3/4 x 3 1/2 - 26
C Rails (4)	1 3/4 x 3 1/2 - 19
D Legs (4)	1 3/4 x 3 1/2 (Custom Length)
E Fixed Top (1)	1 3/4 x 8 1/2 - 30
F Movable Top (1)	1 3/4 x 15 1/2 - 30
G Guide Blocks (2)	1 3/4 x 1 3/4 - 14
H Connecting Rail (1)	1 3/4 x 3 1/2 - 20 1/4
I Spacer (1)	1 3/4 x 3 1/2 - 4 1/2
J Arm (1)	1 3/4 x 3 1/2 - 23 1/2
K Front Block (1)	1 3/4 x 1 1/2 - 1 3/4
L Side Blocks (2)	1 3/4 x 5 - 1 3/4

### Cabinet

M Top/Bottom (2)	21 1/2 x 22 - 3/4" Ply.
N Sides (2)	21 1/2 x 12 1/2 - 3/4" Ply.
O Divider (1)	21 1/4 x 12 1/2 - 3/4" Ply.
P Edging	1/4 x 3/4 (20 Linear Ft.)
Q Back (1)	12 1/2 x 21 1/2 - 1/4" Hrdbrd.

### Drawers & Doors

R Fronts/Bks., Shallow (4)	1/2 x 3 - 5 3/4
S Sides, Shallow (4)	1/2 x 3 - 21 1/4
T Bottoms, Small (3)	5 1/4 x 20 3/4 - 1/4" Hrdbrd.
U Fronts/Backs, Deep (2)	1/2 x 5 3/4 - 5 3/4
Y Sides, Deep (2)	1/2 x 5 3/4 - 21 1/4
W Front/Back, Wide (2)	1/2 x 3 - 14

### Drawers & Doors (con't.)

X Sides, Wide (2)	1/2 x 3 - 21 1/4
Y Bottom, Large (1)	13 1/2 x 20 3/4 - 1/4" Hardboard
Z Stops	1/4 x 3/4 (2 Linear Ft.)
AA Doors (2)	5 7/8 x 8 1/8 - 3/4" Ply.
BB Wide Edging (2)	3/4 x 1 - 8 1/8

## Hardware

- (16) 5/16" x 3" Lag Screws
- (8) 5/16" x 2 1/2" Lag Screws
- (4) 5/16" x 5" Lag Screws
- (28) 5/16" Flat Washers
- (1) 3/8" x 11" Threaded Rod
- (1) 3/8" x 14" Threaded Rod
- (3) 3/4" x 1 3/4" Cross-Dowels
- (2) 3/8" I.D. x 1" Long Nylon Bushings
- (1) 3/8" I.D. x 1" Long Bronze Bushing
- (3) 3/8" Fender Washers
- (3) 3/8" Hex Nuts
- (2) 3/8" x 1 1/8" Coupling Nuts
- (8) 1/2" x 1/2" - 20 3/4" Aluminum Angle (1/8" thick)
- (28) #6 x 1 1/2" Fh Woodscrews
- (1) 1/2" x 4" Hex Bolt
- (1) 1/2" Flat Washer
- (1) 1/2" Lock Nut
- (2 pairs) 125° Inset Hinges
- (20) 1" Wire Brads
- (2) 6" Vise Handles\*

To order a kit that includes all hardware (except bench dogs), call ShopNotes Project Supplies at 800-347-5105.

Kit No. 6830-200.....\$128.95

\*Note: Vise handles are available individually from Reid Tool Supply (800-253-0421). Part No. A5C3T

# Base

I started on the bench by making the base. To provide rock-solid support for the benchtop, it consists of a top and bottom frame and four interlocking legs — all made from 1<sup>3</sup>/<sub>4</sub>"-thick hardwood (maple), see drawing.

**FRAMES.** To support the end vise (added later), the bottom frame has a *long stretcher* (A) that cantilevers out past the base, see Fig. 1. But otherwise the *short stretchers* (B) and *rails* (C) of each frame are identical in size.

The rails fit in dadoes cut near the ends of each stretcher, see Figs. 1a and 1b. But before assembling these pieces, it's best to drill a number of holes.

**DRILL HOLES.** A pair of counterbored shank holes in each rail will provide a way to attach the frames to the legs. And a single hole near the end of the long stretcher (A) will serve as a pivot point for the end vise.

There are also several holes drilled in the top frame only. To attach the fixed top later, I drilled two holes in the front stretcher and a single one in each

rail, see Fig. 1a. And there's a hole near the bottom edge of the front stretcher for the front vise.

After drilling the holes, you can assemble the frames. They're simply glued and fastened together with lag screws, see Fig. 1.

**LEGS.** With the frames complete, I added the four *legs* (D), see Fig. 2. The length of the legs determines the height of your

workbench. To provide a comfortable working height, a good rule of thumb is to measure the distance between your wrist and the floor, then subtract the thickness of the benchtop (1<sup>3</sup>/<sub>4</sub>"). In my case, the legs were 28" long.

**NOTCHES.** The next step is to cut notches in the legs to accept the frames. Since both the front and the back pair of legs are

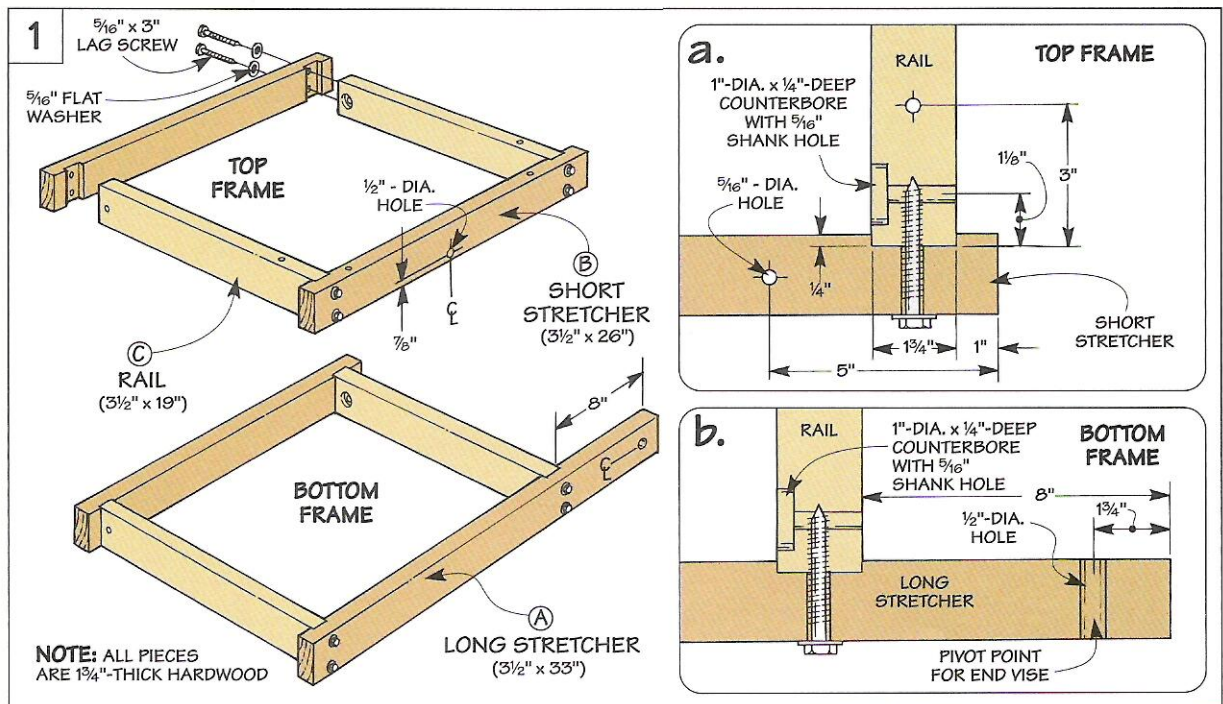
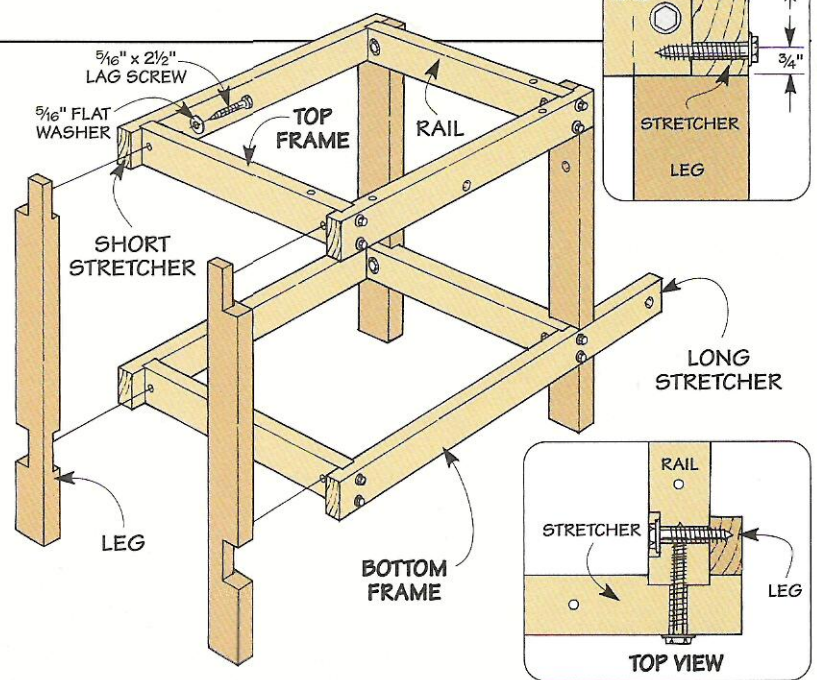

mirror images, it's easy to accidentally cut a notch in the wrong place. So I used a simple technique to keep things straight.

Start by cutting a rabbet and a dado in each leg, see Step 1 in Fig. 2. Then temporarily carpet tape the mirrored pairs together and cut notches in the edges of the legs, see Step 2.

Before assembling the base, you'll need to drill two intersecting holes in the right front leg for the end vise, see detail 'a.' A large, stopped hole is drilled in the inside edge. And there's a smaller, through hole in the face of the leg.

**ASSEMBLY.** All that's left to complete the base is to attach the frames to the legs. They're held in place with glue and lag screws that pass through the holes in the rails drilled earlier.

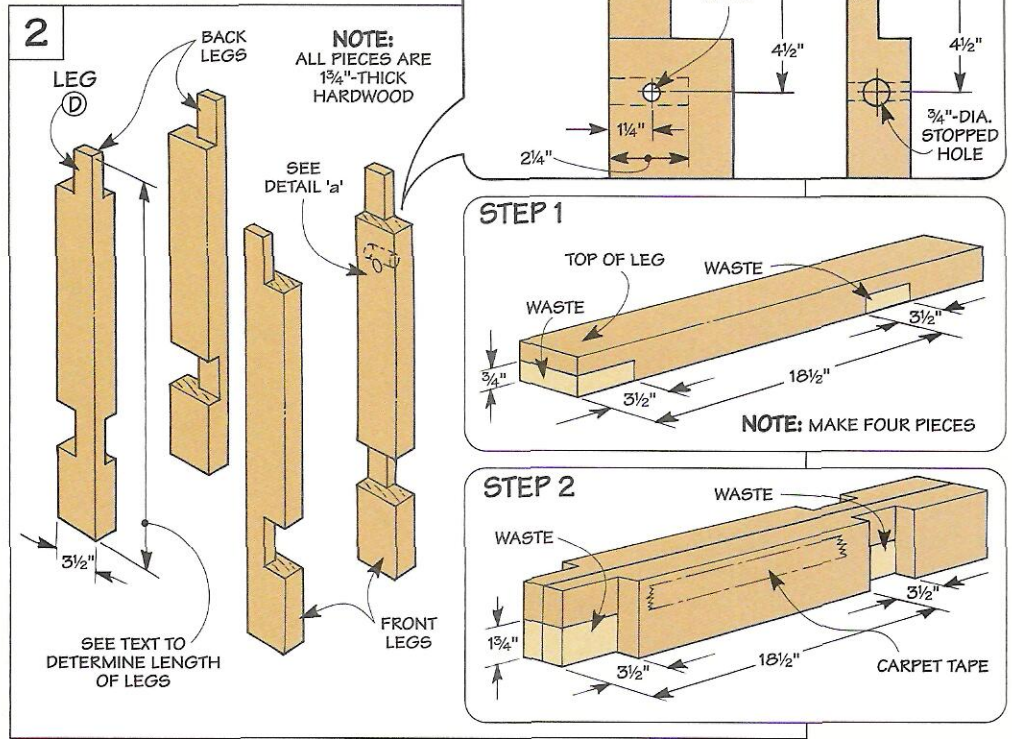

## Top

The top of this workbench does more than provide a solid work surface. It also doubles as a vise.

To make this work, the top consists of two thick slabs that act as the "jaws" of the vise, see Fig. 3. The front part is attached to the base. And the back part slides back and forth to open and close the top. This means you can clamp a project *between* the two parts. Or use bench dogs to clamp work *flat* against the top.

**GLUE-UP.** To build the top, I started by gluing up the two slabs from pieces of 1 3/4"-thick hardwood. After sanding both workpieces nice and flat, it's just a matter of cutting the *fixed top* (E) and *movable top* (F) to size, see Fig. 3.

**DOG HOLES.** The next step is to drill holes for the bench dogs. Two rows of holes across the width of both top parts will be used with the front vise. And there's a single row along the length of the fixed top for the end vise.

Note: I used 2 3/8"-long brass *Bench Pups* made by Veritas. (They're available in many woodworking catalogs.) But you can also make your own, see margin.

After chamfering the holes (Fig. 3a) and outside edges only of the top pieces, you can attach the fixed top. It's fastened to the base with lag screws, see Fig. 3b.



To make a simple bench dog, cut the threads off a bolt, and grind the sides of the head at a slight angle.

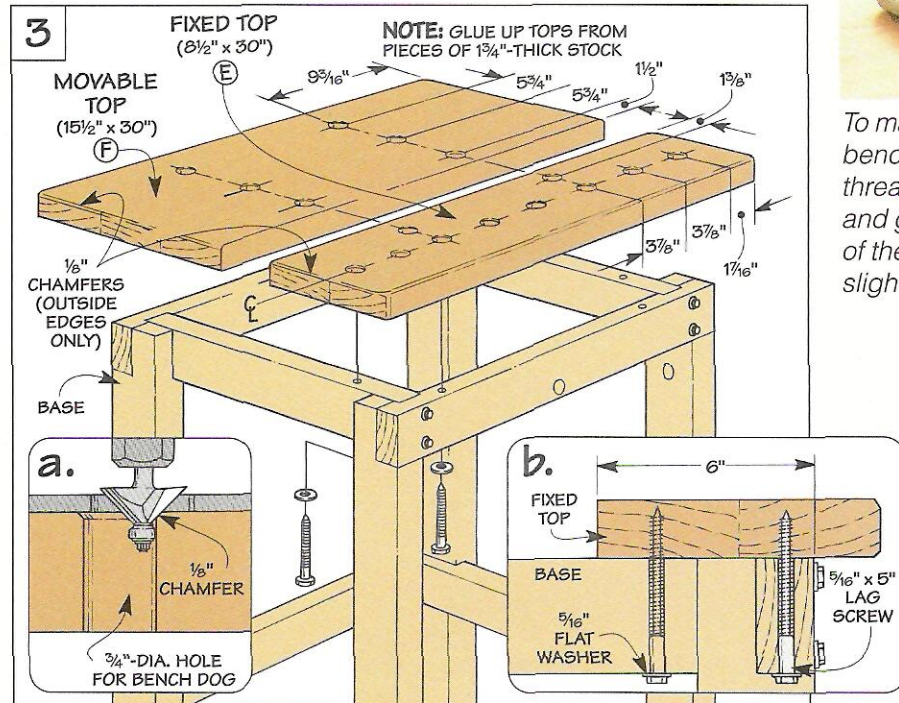

# Front Vise

With the top complete, you still need a way to make it open and close. That's the job of the front vise.

The basic operation of this vise is simple. There's a U-shaped guide assembly that's attached to the movable top, see Fig. 5. As you turn a threaded rod that's connected to this assembly, it opens and closes the vise.

**GUIDE BLOCKS.** To prevent the vise from racking, two *guide blocks* (G) track the movable top along the rails (C) of the base, see Fig. 6. They need to be almost (but not quite) touching the rails to keep the vise from binding.

To locate the guide blocks, start by flipping the top and base upside down. Then use a scrap that's the same width as the maximum opening of the vise (3½") to position the movable top. With shims between the guide blocks and rails (I used playing cards), just screw the blocks in place, see Figs. 6a and 6b.

**CONNECTING RAIL.** The guide blocks are tied together with a *connecting rail* (H), see Fig. 7. It transfers the rotation of the threaded rod to the movable top.

To make this work, you'll need to drill two intersecting holes in the connecting rail — one for the

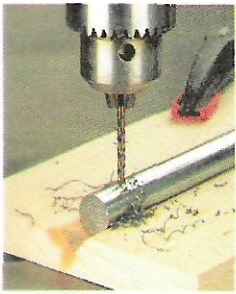
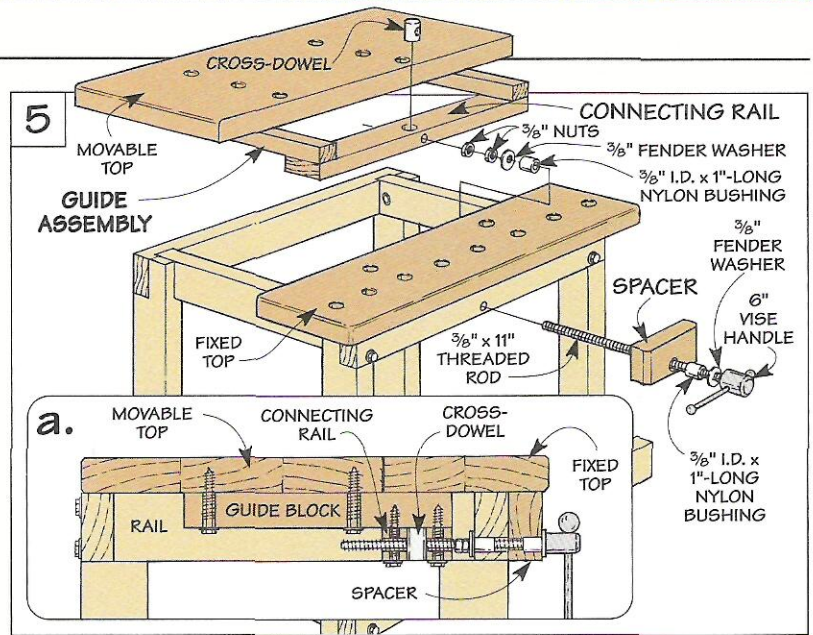

To make a cross-dowel, drill progressively larger holes (up to 5/16") in a steel rod that's clamped in a V-shaped block.

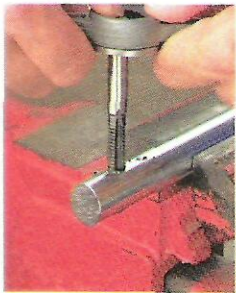

Then just cut the threads in the hole with a 3/8-16 tap and a T-handled wrench.

threaded rod and the other for a short, steel cross-dowel that's drilled and tapped to accept the threaded rod. (I cut a dowel from a length of steel rod, see margin.)

To locate the hole for the rod, set the connecting rail on the guide blocks (with the top closed) and mark the centerpoint, see Fig. 7a. Then use this same centerpoint to locate and drill a 3/4"-Dia. hole for the cross-dowel.

**SPACER.** After attaching the connecting rail, I added a *spacer* (I), see Fig. 7. It's just a block that allows the handle of the vise to clear the benchtop. Before

attaching the spacer, you'll need to locate and drill a counterbored shank hole for the threaded rod and a nylon bushing, see Fig. 7b. Then chamfer the front corners and glue the spacer in place.

**ASSEMBLY.** Now you're ready to assemble the vise, see Fig. 5a. The handle is epoxied to the threaded rod. After installing two nylon bushings to support the rod (one in the spacer and the other in the top frame), it's captured with a washer and two "jam" nuts. To complete the vise, slip the cross-dowel in place and thread the rod into it.

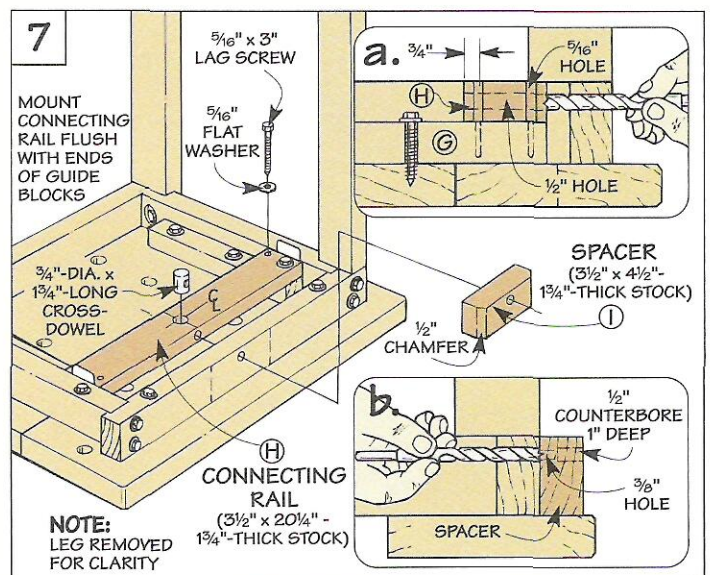
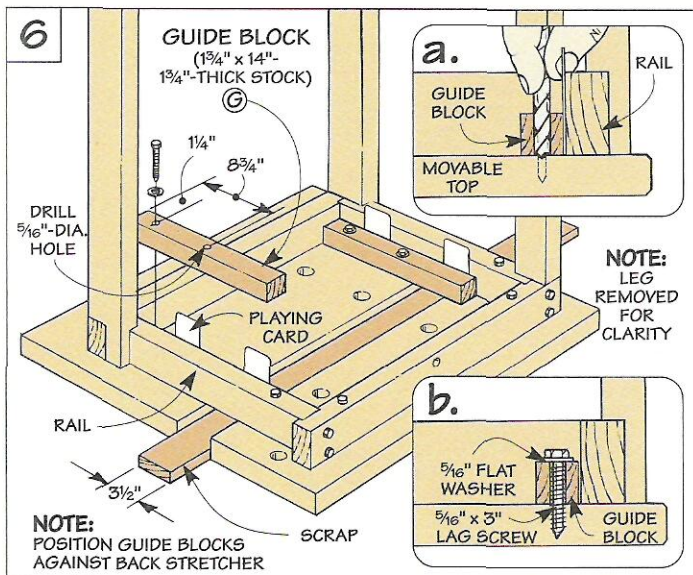

# End Vise

To provide more clamping options, there's also a vise on the *end* of the workbench.

As you tighten this end vise, a long, vertical arm pivots on the long stretcher (A) and moves the clamp head toward the fixed top, see Fig. 8. So you can either hold a workpiece between the clamp head and the benchtop. Or use bench dogs to clamp work flat.

**ARM.** The arm (J) is just a piece of 1 3/4"-thick hardwood with an oversize rabbet at the bottom, see Fig. 9. A hole near the bottom serves as the pivot point. And two intersecting holes at the top will be used to mount the vise. (The slotted hole allows the threaded rod to move up and

down as the arm pivots.)

**CLAMP HEAD.** With the arm complete, the clamp head is built up around it using three hardwood blocks, see Fig. 10.

The front block (K) has an angled hole for a bench dog drilled in it before gluing it in place, see Fig. 10a. This ensures that the bench dog applies pressure *downward* so the workpiece will stay flat on the bench.

After gluing on the two side blocks (L), I sanded a slight curve on the face of the clamp head, see Fig. 11. This way, the two clamping surfaces will be parallel — regardless of the position of the arm. So you'll always get good clamping pressure.

**INSTALL VISE.** After attaching the arm with a bolt and lock nut, you can install the vise. As before, the handle is epoxied onto the threaded rod. But this time, the rod passes through *two* cross-dowels.

The one that fits in the leg produces the clamping pressure, so it's threaded. But since the cross-dowel in the arm just keeps the rod aligned, I simply drilled an oversize hole (no threads).

This cross-dowel is sandwiched between a coupling nut and a spacer (bushing) on one side and another coupling nut on the other, see Fig. 8a. To capture the rod, thread on a hex nut so it's snug. Then to complete the vise, just thread the rod into the leg.

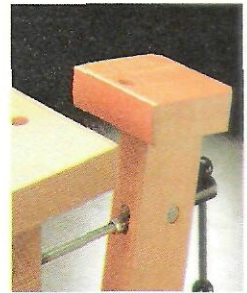

To hold carving blocks securely in place, you can glue leather strips to each clamping surface.

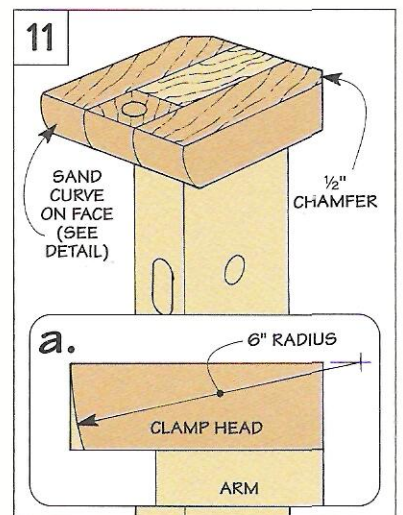
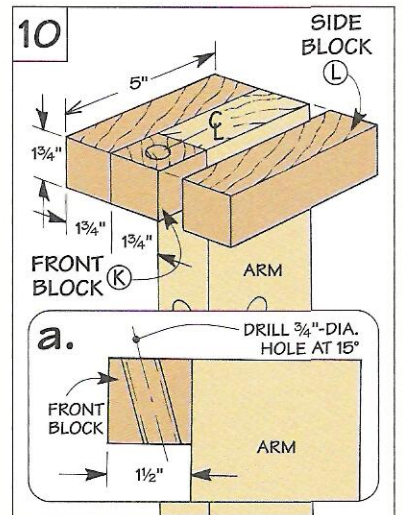
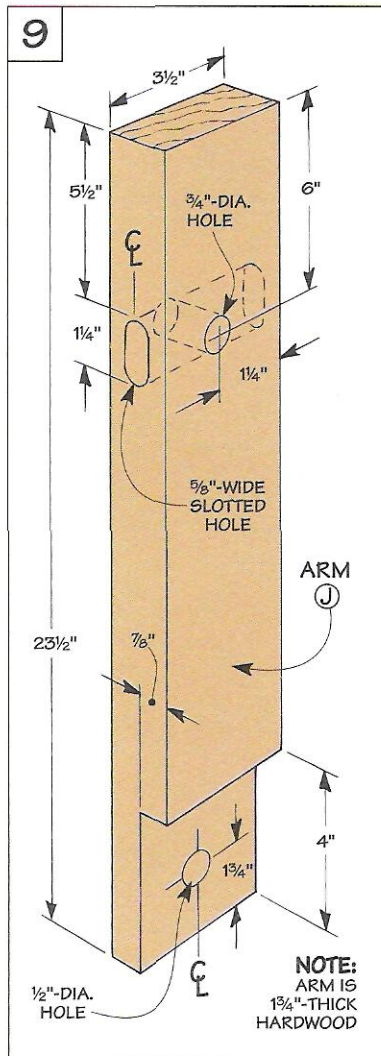
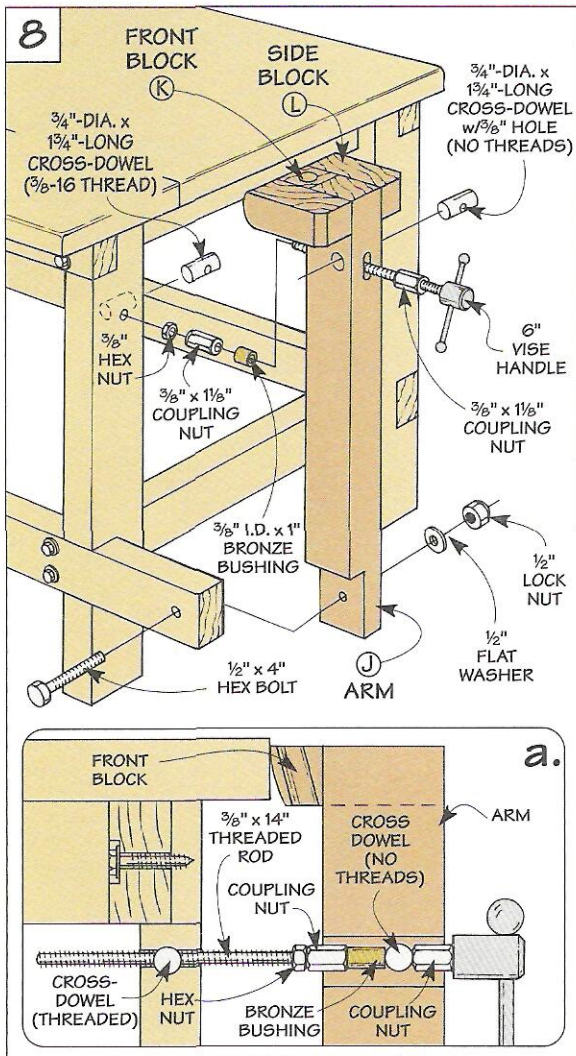

# Cabinet

As soon as the workbench was complete, I set about building my first project on it — a storage cabinet that slips into the base.

The cabinet is simply a plywood case that's divided into two compartments — a narrow one on the left and a wide compartment on the right, see Fig. 12.

**CASE.** The case consists of a *top/bottom* (M), two *sides* (N), and a *divider* (O), see Fig. 12. Except for the divider, each piece is rabbeted on the back inside edge for a back that's added later, see Figs. 12 and 12b.

To help strengthen the case, the pieces are held together with tongue and dado joints. But before cutting these joints, it's easiest to cover the exposed ends of the top and bottom. I just glued on  $\frac{1}{4}$ "-thick hardwood edging (P), see Fig. 12.

After sanding the edging flush with the plywood, you can cut the dados in the top and bottom, see Fig. 12a. Then cut the tongues on the sides and dividers to fit.

**GUIDES.** Before gluing the case together, there's one more thing to do. That's to add the drawer guides. The unusual thing about these guides is they're made from pieces of aluminum angle,

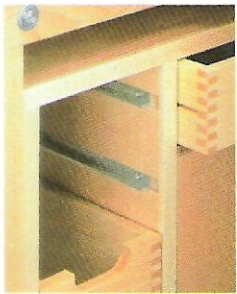
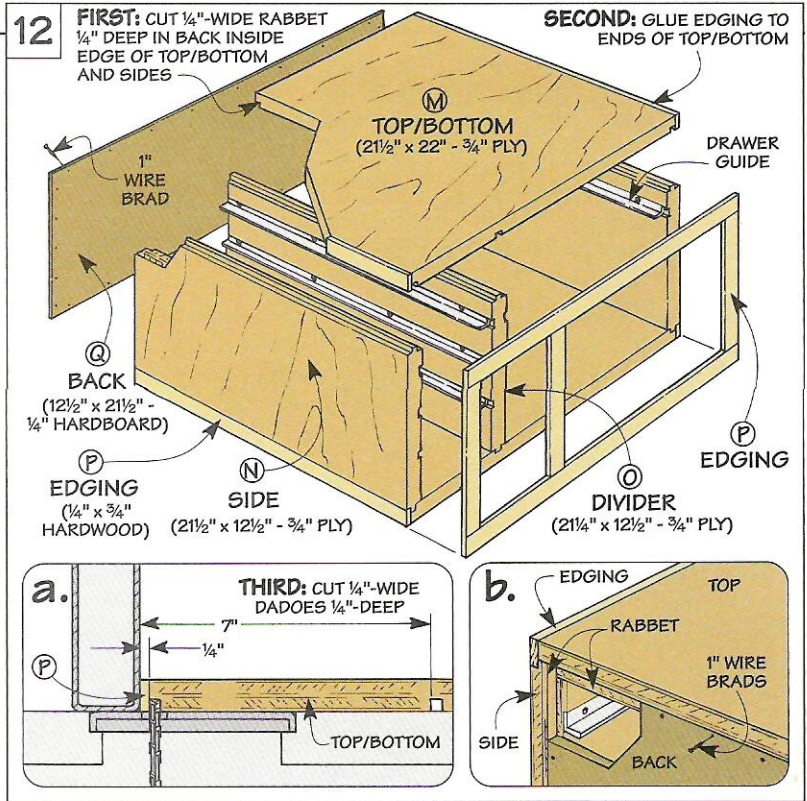

To keep the drawers from binding, they ride on guides made from pieces of aluminum angle.

see margin and Fig. 13. The reason for this is simple.

The aluminum won't expand and contract with changes in humidity. So the drawers won't bind like they sometimes do with wood guides. And the aluminum angle is less expensive than buying manufactured drawer guides.

To make it easy to align the drawer guides, they fit in dados

cut in the sides and divider, see Fig. 13. After drilling countersinks in the guides, they're simply screwed in place, see Fig. 13a.

**ASSEMBLY.** All that's left is to assemble the case. To keep it square during glue-up, I cut a *back* (Q) to fit and used brads to hold it in place, see Fig. 12b. Then I glued on *edging* (P) to cover the front edges of the case.

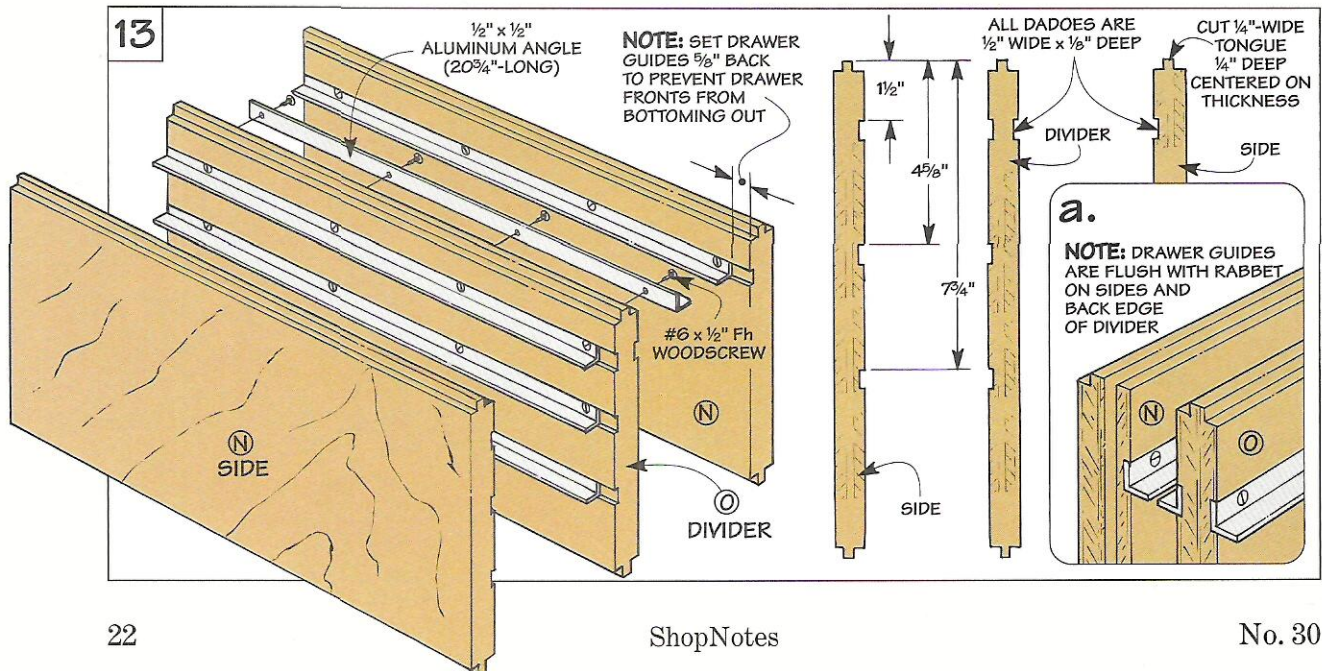

# Drawers & Doors

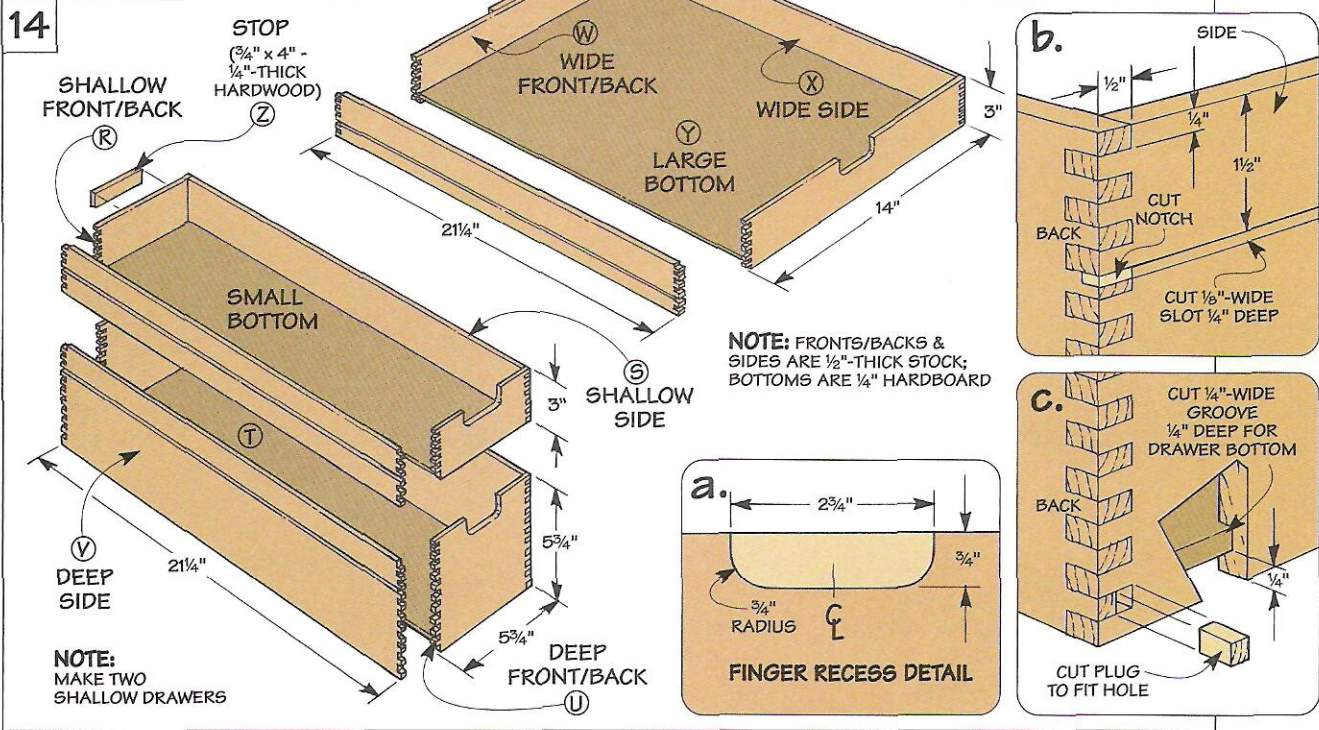

Once the case is complete, it's just a matter of building the drawers and doors to fit inside.

**DRAWERS.** To provide storage for different size tools, there are two shallow drawers and a deep drawer on the left, and a wide drawer on the right, see Fig. 15.

**BOX JOINTS.** Each drawer is held together with box joints, see Fig. 14. The pins of the box joints extend all the way through the *fronts/backs* (R, U, W) and *sides* (S, V, X) of the drawers. So start by cutting these pieces to size. (I used  $\frac{1}{2}$ "-thick stock and allowed for a  $\frac{1}{8}$ " gap all around.)

Now you can cut the box joints. To get the bottoms of the slots perfectly flat, I routed the slots using a straight bit. (For a step-by-step article on routing box joints, refer to *ShopNotes* No. 22.)

**GROOVES.** Next, you'll need to cut grooves in the sides for the aluminum drawer guides, see Fig. 14b. Also, there's a groove in each piece for the drawer *bottoms* (T, Y), see Fig. 14c.

Before gluing up the drawers,

it's easiest to cut a finger recess in the drawer fronts, see Fig. 14a. Then after the glue dries, cut a notch in the back corners so the drawers can slide onto the guides, and plug the holes in the sides, see Figs. 14b and 14c.

**STOP.** To complete the drawers, I glued a *stop* (Z) to the back of each one and planed it until the fronts were flush with the cabinet.

**DOORS.** All that's left is to add the two *doors* (AA), see Fig. 15. These are pieces of  $\frac{3}{4}$ " plywood that are trimmed with hardwood edging. A *wide trim piece* (BB) with a finger recess is glued to the inside edge of each door. And thin strips of *edging* (P) cover the other edges. After gluing on a stop (Z), I mounted the doors with European-style hinges.

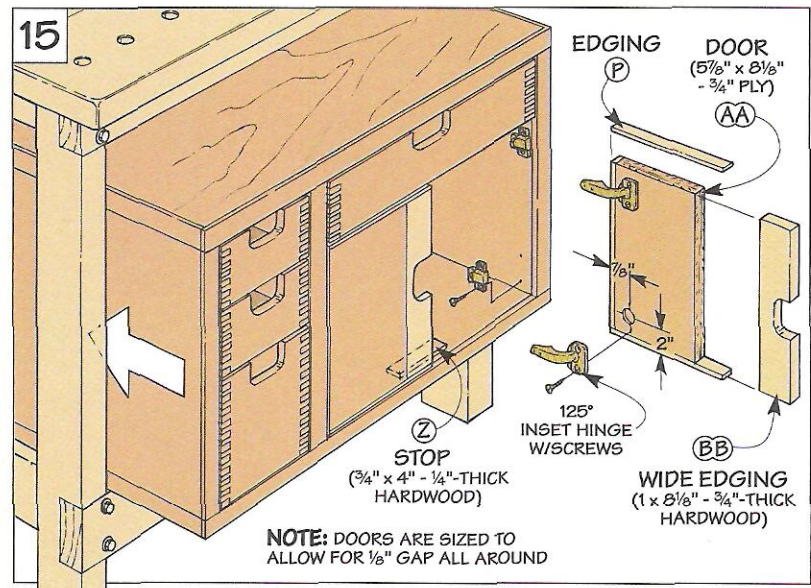

# Drop-Down Tool Tray

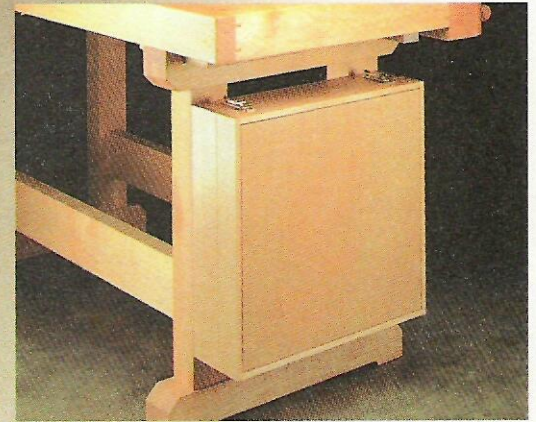

**K**eeping my bench cleared off sometimes seems like a losing battle. Even when I'm working on a simple project, tools and materials have a way of piling up on top.

Usually, this clutter just gets in the way. But every once in awhile, one of my tools gets knocked to the floor. In fact, I was picking up a chisel (freshly sharpened of course) when the idea for this tool tray hit me.

It hangs under the bench in a space that usually just goes to waste, see photos above. The lid drops down to put the tools I use most in easy reach. And when I'm done using a tool, I just slip it back into the tray — out of the way. A special holder locks each tool in place so it stays put when the lid is closed.

Basically, the tray consists of two parts: a box that holds two adjustable shelves, and the drop-

down lid. But rather than make each part separately, I built a single box and then cut it apart to form the lid. This ensures a good fit between the box and the lid.

**TONGUE & DADO.** The box consists of a *top/bottom* (A) and two *sides* (B) that are held together with tongue and dado joints (I used 1/2"-thick maple), see the drawing below.

**GROOVES.** Once you've completed the basic joinery, you'll

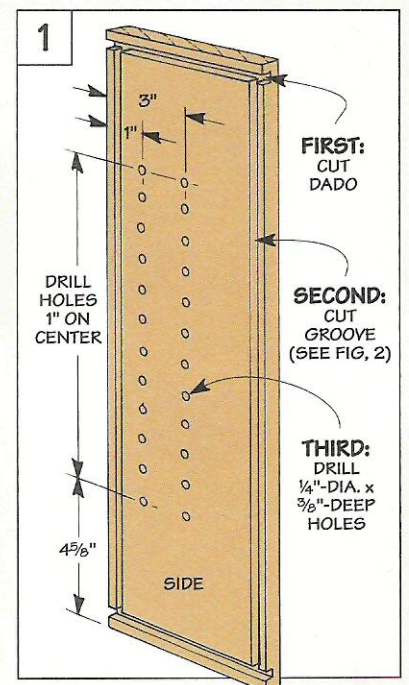
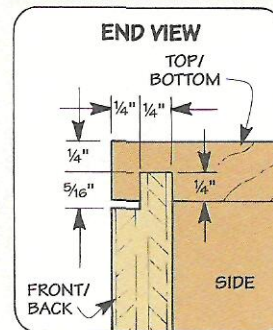
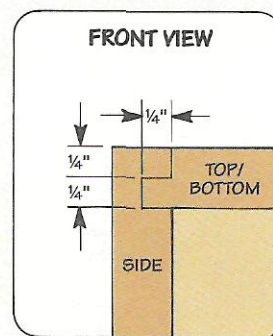
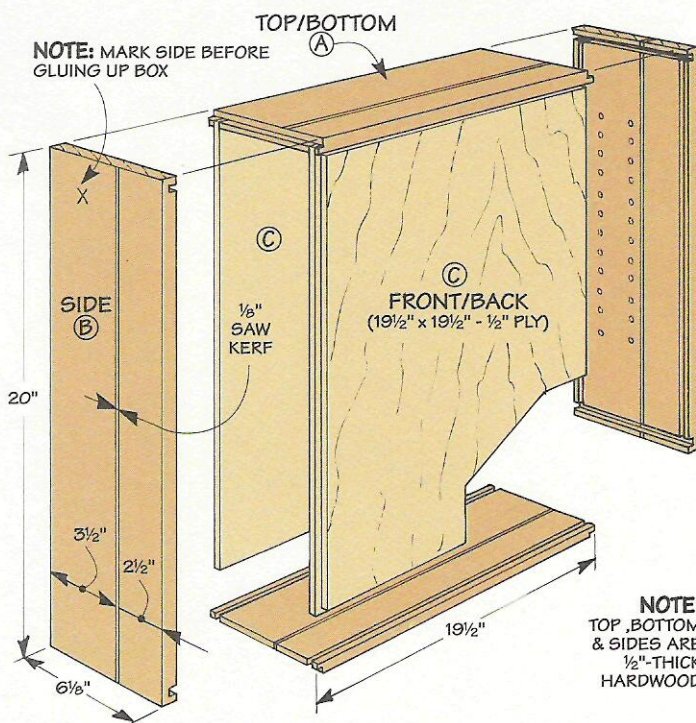



need to cut a pair of grooves in each piece to accept the front and back of the box (added next).

The grooves in the top and bottom run along the entire length. But if you cut the grooves in the sides all the way through, they'll be visible at each end and need to be filled with a wood plug. So instead, I *stopped* the grooves at the dados cut earlier.

An easy way to do this is to rout them on the router table. But first, you need to know where to start and stop each groove.

To do this, make two marks on the router fence — each one  $\frac{3}{8}$ " from the edge of the bit, see Fig. 2a. (I used a  $\frac{1}{4}$ "-straight bit.) The extra  $\frac{1}{8}$ " provides a "fudge factor" so you don't accidentally rout the grooves past the dado.

Now you're ready to rout the grooves. What you want to do here is to carefully lower the workpiece onto the spinning bit so the end aligns with the starting point, see Figs. 2 and 2a. Then rout the groove until the opposite end aligns with the stop mark, and shut off the router, see Fig. 2b. To rout the opposite groove, turn the workpiece end for end and repeat the process.

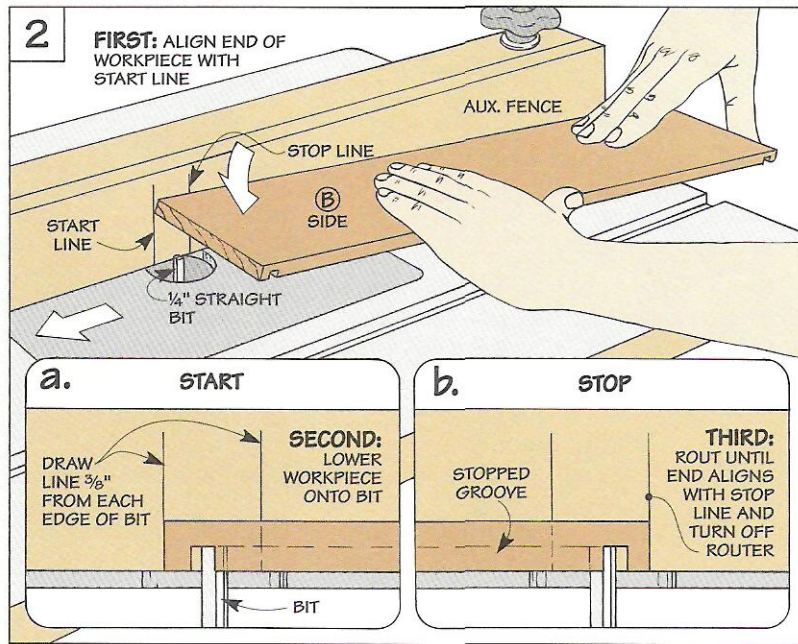

**DRILL HOLES.** The next step is to drill holes in the sides for the shelf support pins, see Fig. 1. Keep in mind that you won't know which part of the box the holes are drilled in once it's assembled. So to keep from accidentally cutting through the holes when you separate the lid from the box, it's a good idea to mark the part with the holes.

**FRONT/BACK.** All that's left to complete the basic box is to add a

plywood *front/back* (C). (I used  $\frac{1}{2}$ "-thick birch). The edges of these pieces are rabbeted to form a tongue that fits the grooves in the box pieces. To create a "shadow line" around the edges of the front and back, I cut the rabbets  $\frac{5}{16}$ " wide.

**ASSEMBLE BOX.** Now it's just a matter of gluing and clamping the pieces of the box together. Once the glue dries, you can cut the lid from the box, see box below.

## Cutting A Lid from A Box

There's nothing complicated about using a table saw to cut a lid from a box.

The key is to set the height of the saw blade so it's slightly *less* ( $\frac{1}{16}$ " ) than the thickness of the box, see Step 1. This leaves a thin membrane that holds the box together and keeps

the kerf from pinching the blade.

Once all four sides are cut, you can sever the membrane by making a series of *light* passes with a knife, see Step 2. The knife and a scrap block also make quick work of cleaning up the ridges left behind, see Step 3.

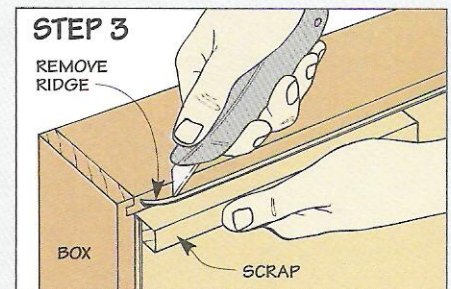
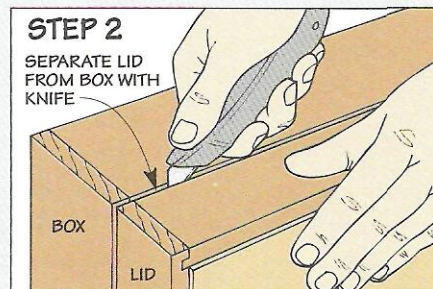
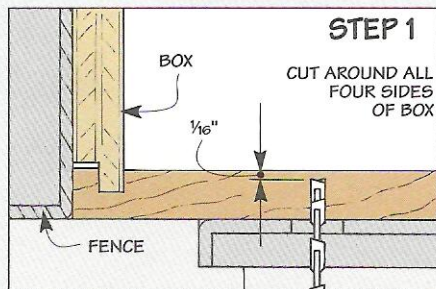
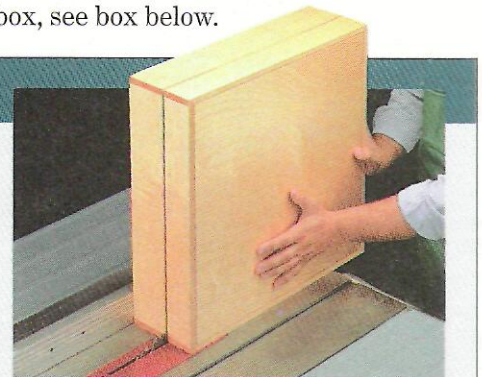

# Hardware & Shelves

At this point, the tool tray is just an empty box with a lid. But adding a few pieces of hardware and a pair of adjustable shelves lets you take advantage of the storage space inside.

**HINGE.** The box and lid are held together with a piano hinge, see Fig. 3. It's recessed into a shallow notch routed in the back edge of each part, see Fig. 3a.

**LID SUPPORTS.** After screwing the hinge in place, I installed a pair of lid supports, see Fig. 4. They support the weight of the lid and the tools inside. To provide easy access, the supports are positioned so they hold the lid open at a slight angle, see Fig. 4a.

**DRAW CATCHES.** Next, to hold the lid closed, I added a pair of draw catches, see Fig. 5. The trick is to position each catch so the bail draws the lid tight. To do this, start by mounting the catch. Then, with the catch in the raised position, set the strike in place so it's snug against the bail on the catch, see Fig. 5a.

**SHELVES.** After installing the draw catches and attaching the tray to the bench (I screwed it to the legs of the bench), all that's left is to add two shelves.

The shelves (D) are 1/2"-thick pieces of hardwood that rest on shelf support pins. Note: You may want to customize a shelf to hold one of your tools, see photo.

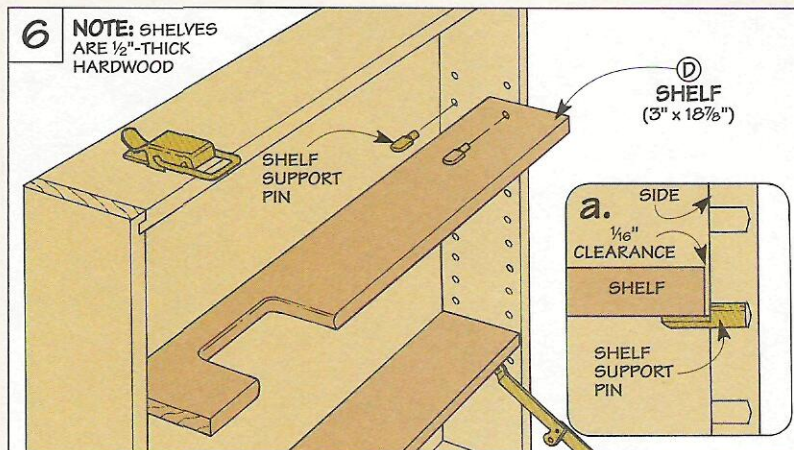
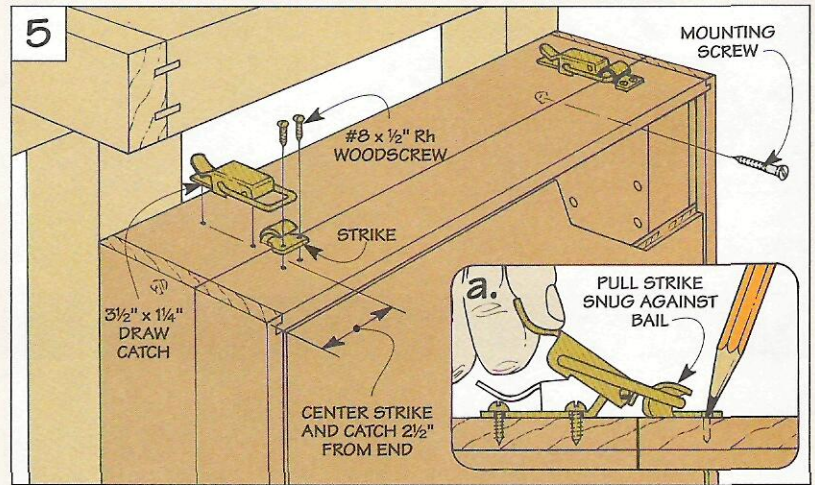
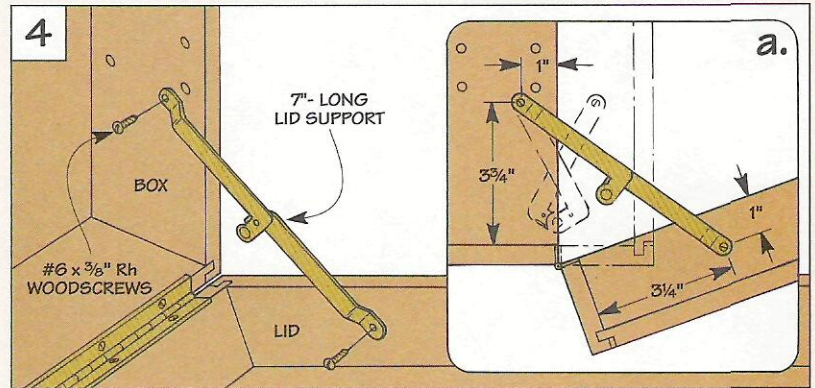
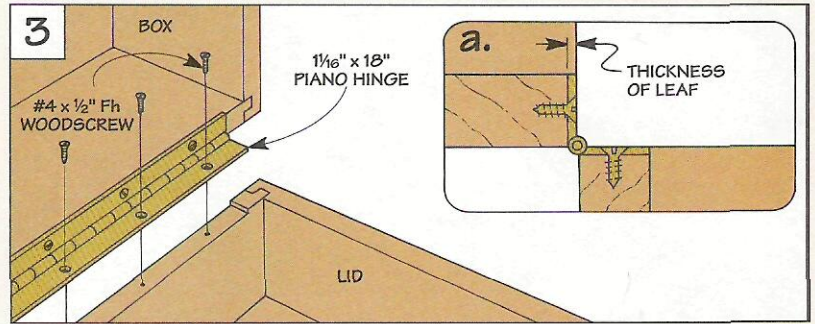

▲ To make a convenient holder for a cordless drill, just cut a simple notch in one of the shelves to fit the handle.

## Hardware

- (1) 1/16" x 18" Piano Hinge (Brass)
- (1B) #4 x 1/2" Fh Woodscrew (Brass)
- (2) 7"-Long Lid Supports (Brass)
- (4) #6 x 3/8" Rh Woodscrew (Brass)
- (2) 3 1/2" x 1/4" Draw Catches (Brass)
- (8) #8 x 1/2" Rh Woodscrew (Brass)
- (8) Shelf Support Pins (Brass)

For a complete hardware kit, call 800-347-5105. 6830-300.....\$19.95

# Tool Holders

## Flat-Bladed Tool Holders

To hold a tool with a flat blade (like a square, scraper, or saw), all it takes is two pieces of scrap.

A kerf in one piece captures the

blade, see drawing below. And a rabbet in the other one allows you to easily remove the tool and put it back in. To hold the blade flat, just be sure the bottoms of the kerf and rabbet align.

To save space inside the lid, keep in mind that one piece can do double duty. Take the middle piece in the drawing at left for instance. It acts as one part of the holder for two different squares.

After attaching the holders with screws, I added a wood turnbuckle to lock the tools in place, see margin.

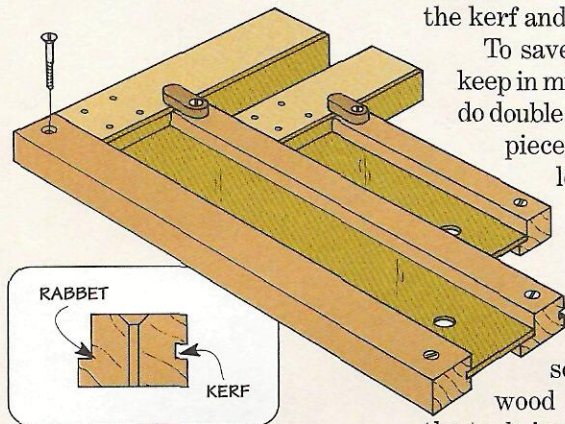

## Contoured Tool Holders

It's a bit trickier making a holder for a tool with a curved surface. So these holders are shaped to fit the contour of the tool.

**DOUBLE-END.** To hold my screwdrivers, awl, and mallet, both ends of each tool are captured between two blocks.

One has a hole that creates a pocket for the blade (or the handle of the mallet), see drawing below. The other has a curved notch that fits the shape of the opposite end of the tool. As before, a wood turnbuckle locks the tool in place.

But securing both ends of a chisel presents a problem. That's because the blade gets shorter as it's sharpened. And eventually, it will be too short to fit between the blocks.

**SINGLE-END.** The solution is a holder that lets the blade end of the chisel "float." With this type of holder, the handles fit in holes in one block. And the neck of each chisel slips into an open notch in a center block.

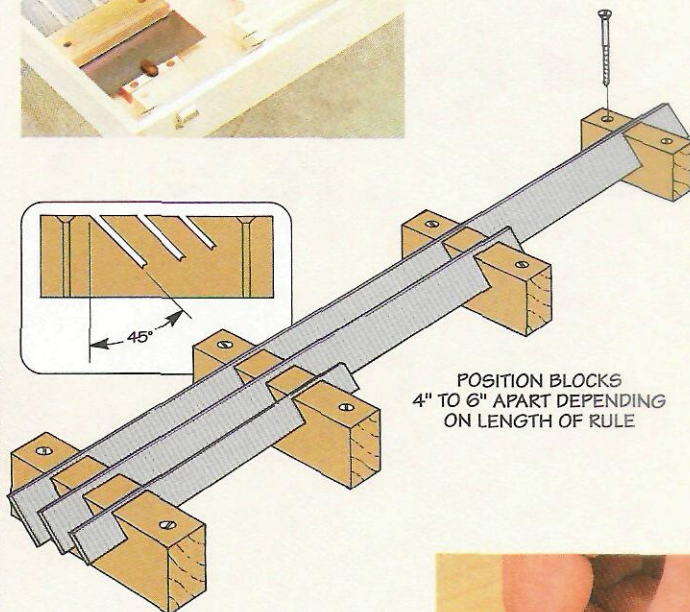
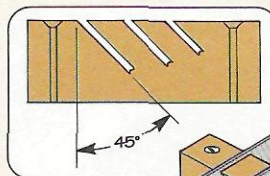
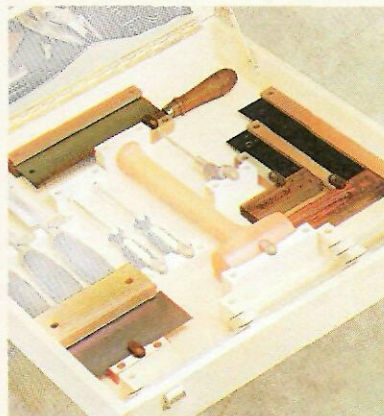
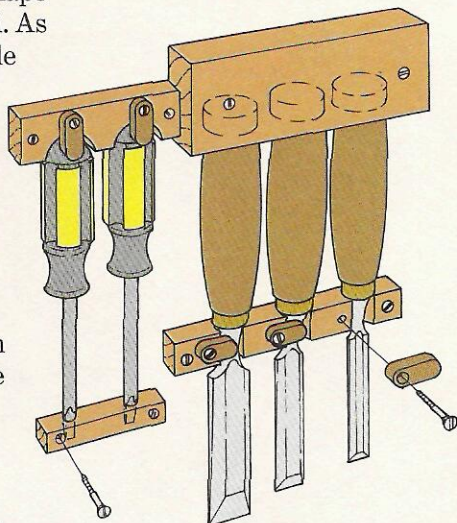

## Metal Rule Holders

Wood blocks with a series of kerfs cut at an angle — that's all there is to the holders for these metal rules, see drawings above.

Varying the depth of the kerfs keeps rules of different widths flush at the top. And positioning the blocks so the kerfs face up keeps rules from falling out.



▲ Small turnbuckles made of walnut prevent tools from falling out. To slip easily over the tool, you may need to sand a slight bevel on the end.

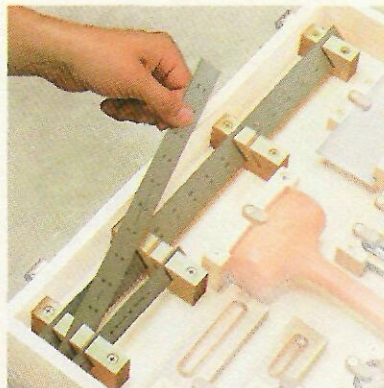

# Shop Solutions

## Locking Tool Base

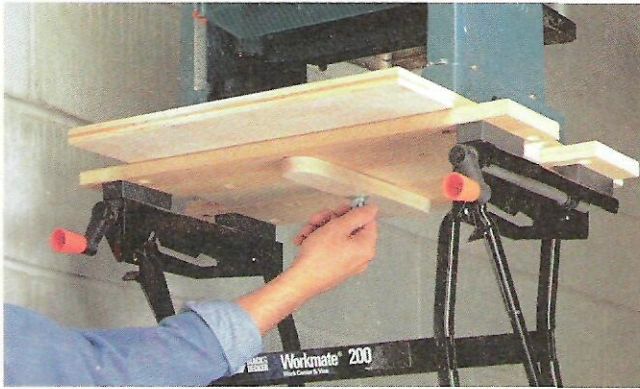

■ Like many woodworkers, I mount my benchtop tools to plywood bases and use a *Workmate* to support them. The bases are held in place by tightening the “jaws” of the *Workmate* against a cleat that’s screwed to the bottom of the base, see drawing.

But some of my tools set up more vibration than I like. And I’m concerned about the holding power of the jaws. So in order to provide some additional “insurance,” I added a wood turnbuckle

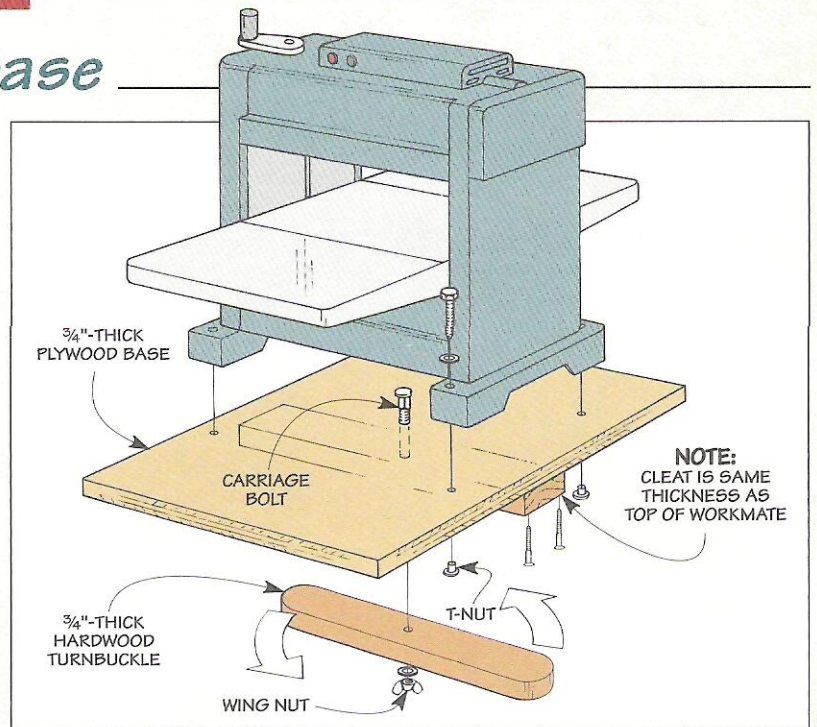

to each base, see photo.

The turnbuckle is just a piece of 3/4"-thick hardwood that’s centered on the cleat. It’s attached with a carriage bolt and wing nut that pass through holes drilled in the base and turnbuckle.

To quickly secure a tool, just set the base in place and tighten the jaws of the *Workmate*. Then rotate the turnbuckle a quarter turn to lock the base in place.

*Richard Weber  
Sheboygan, Wisconsin*

## Band Saw Shelf

■ When working with small pieces at my band saw, there isn’t a handy place to set them aside. So I attached a plywood shelf to the arm of the saw, see drawing.

To provide clearance for the lower door of the band saw, the shelf is built up above the arm with a spacer block. The spacer block is attached by threading machine screws into holes that are drilled and tapped in the cast iron arm, see detail.

With the spacer block in place, just attach the shelf with screws.

*Ralph Meermans  
Bay Village, Ohio*

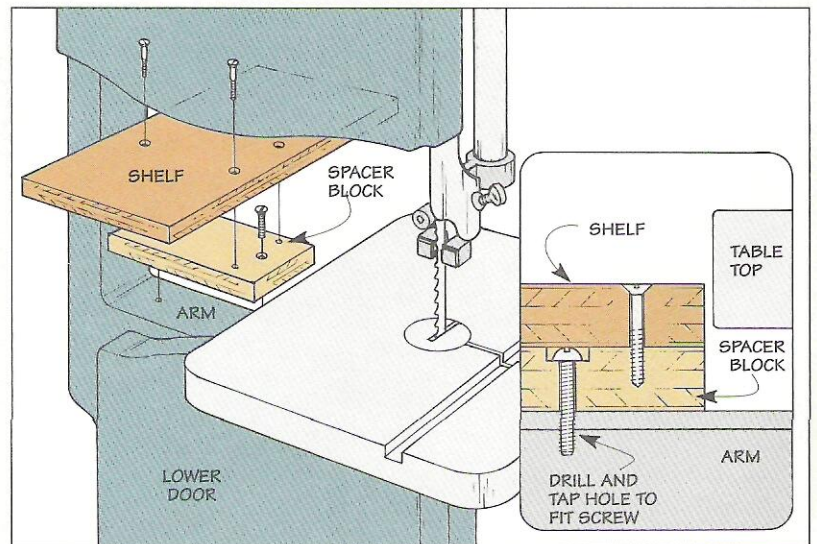

## Quick Tips

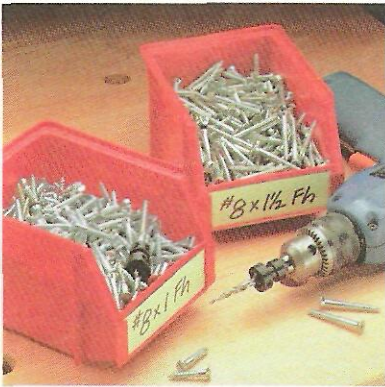

▲ To install screws quickly, Kirk Evans of Parkton, Maryland stores a preset combination bit with the lengths he uses most often.

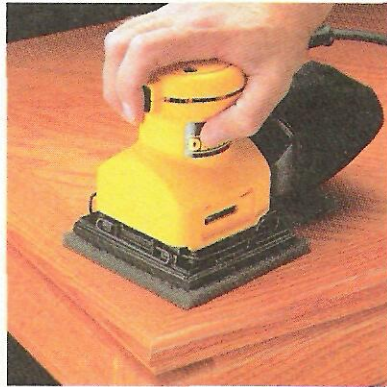

▲ By placing an abrasive pad under his sander, T.L. Mansfield from Louisa, Virginia makes quick work of smoothing a finish.

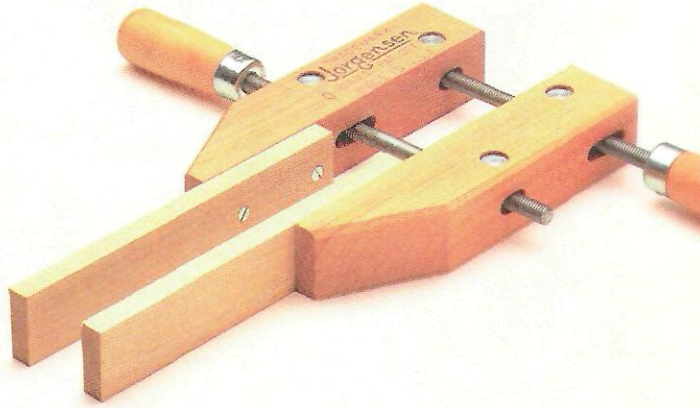

▲ To clamp hard to reach areas, Michael Burton of Glorieta, New Mexico screws wood extensions to the jaws of a hand screw.

## Box Joint Tip

■ When using box joints to hold a drawer together, I used to rout grooves for the bottom *before* assembly. But the ends of the grooves show up as holes that need to be plugged (or filled)

after the drawer is assembled.

To eliminate the holes altogether, I dry assemble the drawer and rout the grooves with a slot cutter, see Fig. 1. This requires replacing the small bearing on the

slot cutter with a large one so you don't cut through the drawer.

You'll also need to sand the corners of the bottom to fit, see Fig. 2.

*Ed Sepkowski  
Rochester, New York*

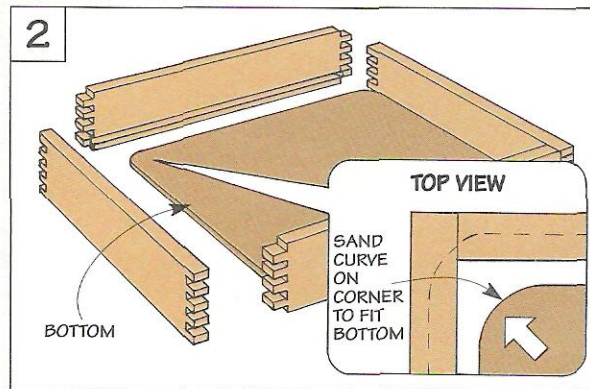
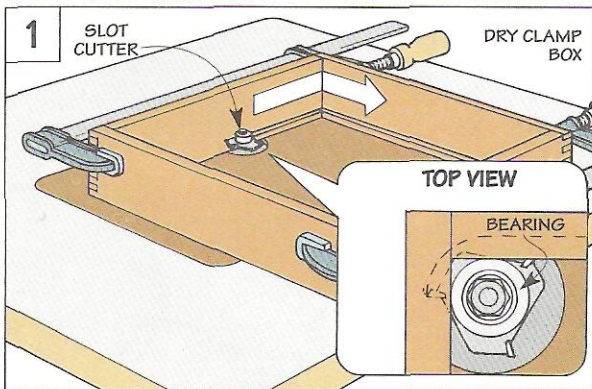

## Shop Vacuum Handle

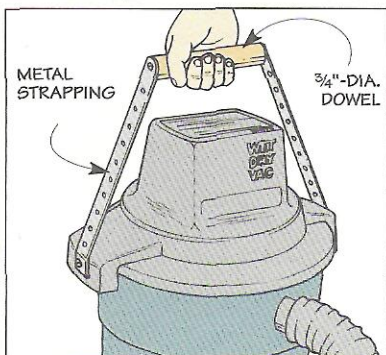

■ One annoying thing about my shop vacuum is it tips over when I tug on the hose. So I made a simple handle to carry it around.

It's just a dowel that's screwed to some light-gauge metal strapping, see drawing. Then the strapping is screwed to the handles of the vacuum.

*David Arrigoni  
San Jose, California*

## Send in Your Solutions

If you'd like to share your original solutions to problems you've faced, send them to: *ShopNotes*, Attn.: Shop Solutions, 2200 Grand Avenue, Des Moines, IA 50312. (Or if it's easier, FAX them to us at: 515-282-6741.)

We'll pay up to \$200 depending on the published length. Please include a daytime phone number so we can call you if we have any questions.

# Wood Moisture



▲ *Checking the moisture content of the wood before you start a project can keep problems from cropping up after it's completed.*

**T**here are few things more frustrating than carefully building a project only to have problems crop up *after* it's completed. For example, a tight-fitting joint pulls apart. A solid wood panel splits. Or a perfectly smooth finish starts to crack.

Although these problems are all different, they can often be traced back to the same thing — the amount of moisture in the wood used to build the project. If it's too wet, the wood shrinks as it dries. Too dry, and it expands as it absorbs moisture.

While some wood movement is unavoidable, the important thing is to keep it to a minimum. And the best way to do that is to take the moisture content of the wood into consideration *before* you start a project.

**MOISTURE CONTENT.** Basically, moisture content (MC) is the amount of water trapped inside a board compared to the weight of the wood when it's dry. This is generally expressed as a percentage.

The ideal moisture content for wood in most parts of the U.S. is around 6% to 8%. But depending on the average humidity of the region, the desired moisture content may vary, see map.

Regardless of the region, the thing to be aware

of is that the wood at the local lumberyard may not necessarily be at that ideal moisture content. So it's a good idea to let wood adjust to the moisture level in your shop before you start, see photo below.

Within a week or two, the moisture in the wood should reach a balance with the moisture in the shop. But you still won't know the *exact* moisture content of the wood.

**MOISTURE LEVEL.** That's why it's a good idea to use a special meter that measures the amount of moisture in wood. These moisture meters have been used by the commercial lumber industry for years. But recently, several manufacturers have

come out with meters for the home shop as well, see Sources in margin.

Basically, there are two types of meters. One is scanned across the board to read the average moisture content, see photo above. The other uses a pair of short, sharp pins that you push into the surface of the board.

Although both types of meters provide accurate results, there are some things to consider if you're thinking of buying one.

As a rule, the meters that use pins are a bit less expensive. But they leave puncture marks in the lumber — which may not go over too well with the guys at the lumberyard. And they aren't as handy to use as the meters that are scanned across the wood. (For tips on using either type of moisture meter, see the box below.) 🛠️

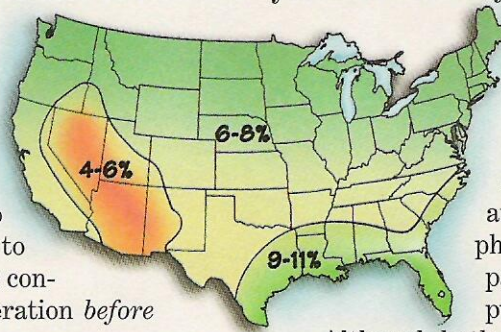

## Sources

- Delmhorst Instrument (Pin Meter)  
Model J-Lite, \$125  
800-222-0638
- Lignomat USA Ltd. (Pin Meter)  
Model Mini-Ligno, \$110  
800-227-2105
- Wagner Electronics (Scan Meter)  
Model L609, \$130  
800-944-7078

## Tips on Using a Moisture Meter

- 1 Multiple Readings.** To get an accurate measurement of the overall moisture content, take several readings and average the results. Especially with softwoods that may not be dried as evenly.
- 2 Ends.** Most moisture escapes from the ends of a board. So to avoid producing an artificially high reading, measure the moisture content at least 6" in from each end.
- 3 Knots.** Since the end grain rises to the surface around a knot, it will also give an abnormally high reading. So steer clear of knots when measuring moisture content.



▲ *To let wood adjust to the moisture level of the air in your shop, stack the boards with short strips in between so the air can circulate around them.*

# Spray Painting a Finish

**L**ike many woodworkers, I occasionally apply a spray-painted finish to a shop project. Not with expensive spray equipment. But using a simple can of spray paint.

While it's hard to imagine a finish that's easier to apply, there's a bit more to it than just shaking up a can and spraying the paint. In fact, even the type of paint you use can affect the quality of the finish.

**ENAMEL.** To create a durable finish, I use enamel spray paints (instead of lacquers). The enamel paints don't chip as easily as lacquer. That's nice for a shop project that's bound to get knocked around with use.

With paint in hand, it's tempting to start spraying right away. But to produce a smooth finish, you'll need to spend some time getting the surfaces ready to paint.

**EDGES.** It's the edges that usually need work. Especially on materials like the Medium-Density Fiberboard we used for the assembly table on page 4. Since the edges are quite porous, they wick up paint like a sponge and make it hard to get a good "build."

So to prevent the edges from absorbing the paint, I fill them with a special putty called *Durham's Rock Hard Water Putty*, see Step 1 below. (It's available at most hardware stores.)

Basically, it's a powder that

you mix with water. Since the mixture will dry extremely hard, you need to sand the edges smooth *before* the putty sets up.

Along with the edges, I also sand the other surfaces. A good "once-over" with 120-grit sandpaper is usually all it takes.

**PRIMER.** With the surfaces sanded smooth, the next step is to apply a coat of primer, see Step 2. The primer provides a base for the paint. And it seals the surface which keeps the paint from discoloring.

When the primer dries, the surface may feel a bit rough. So to lay the groundwork for a smooth finish, it's a good idea to sand the primer *lightly* (I use 220-grit sandpaper.)

**COLOR COAT.** Now you're ready to spray on the color coat. To avoid runs and sags, the idea is to apply several (three to four) light coats of paint instead of a single heavy one, see Step 3.

The thing to be aware of is that in order to get one coat of enamel to adhere to another, you need to apply it within a certain "window." So subsequent coats either need to be sprayed on within the hour (when the paint is still tacky) or after 48 hours (when it's completely dry.)

**CLEAR COATS.** Finally, there's one more thing you can do to add even a bit more protection to the painted finish. To keep it from getting dinged up, I spray on an acrylic clear coat, see Step 4. Here again, it's best to apply three or four light coats. 🛠️

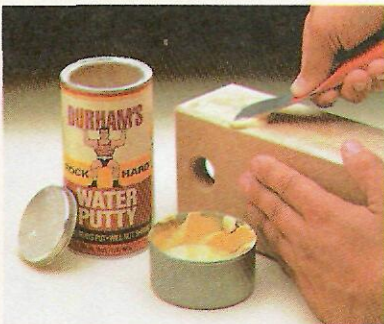
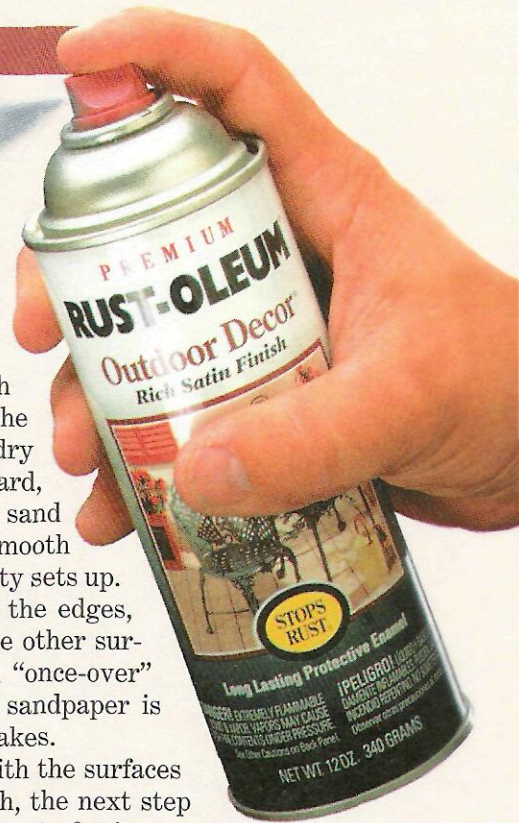

**Step 1.** To prevent the edges from absorbing paint, fill them with putty, then sand them smooth.



**Step 2.** Then apply a primer to provide a base for the paint and keep it from discoloring.

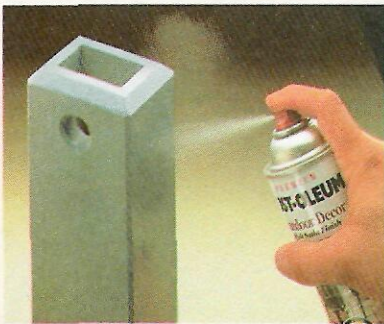

**Step 3.** To ensure uniform coverage, use a sweeping motion as you spray on the color coat.

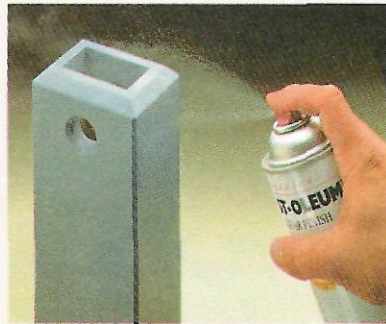

**Step 4.** Finally, spraying on an acrylic clear coat helps to protect the painted finish.

## Scenes from the Shop



▲ About the size of an ordinary card table, the small workbench shown here and on page 16 can be tucked easily into a corner of your house. Just pull up a

stool. Tighten a block of wood in the end vise. (It's specially designed to hold irregular-shaped objects.) Then enjoy a quiet evening of wood carving.

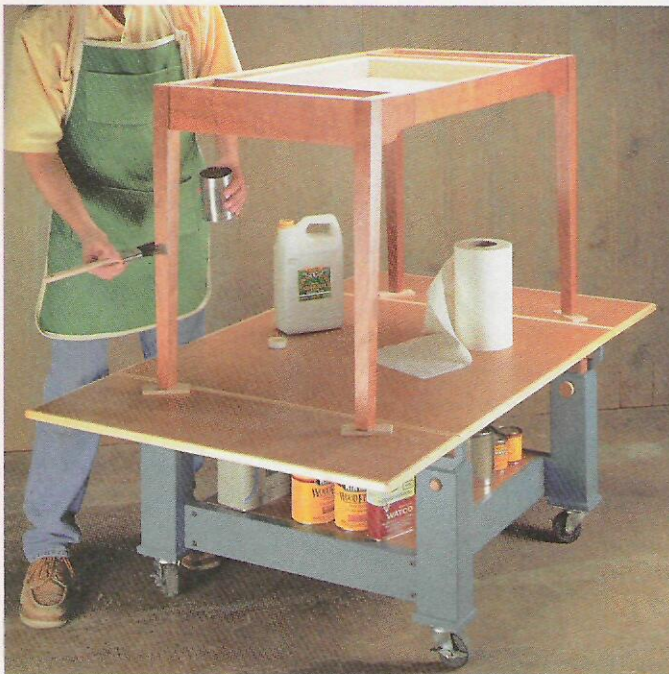

▲ The unique thing about the assembly table featured on page 4 is it adjusts to suit the job at hand. To apply a finish to a large project, lower the table and flip up

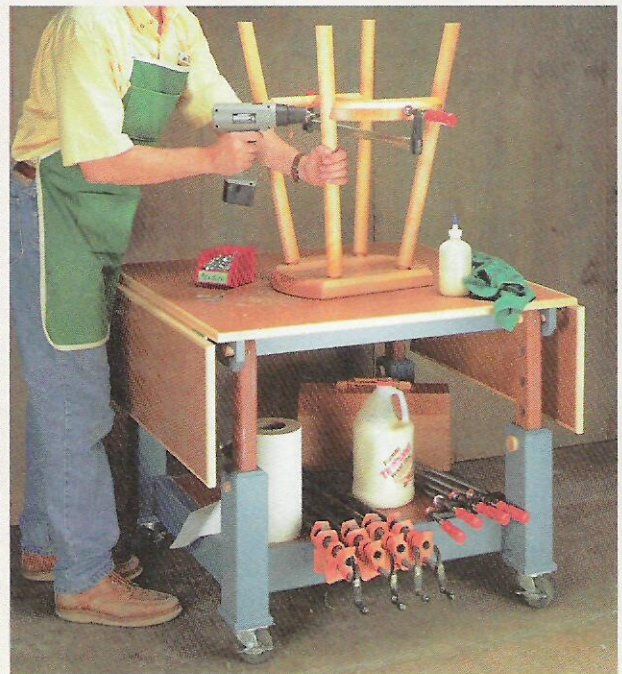

the extension wings (left). Or if you're assembling a smaller project, drop the wings down and raise the table to a comfortable working height (right).