

ShopNotes®

Vol. 6

Issue 31

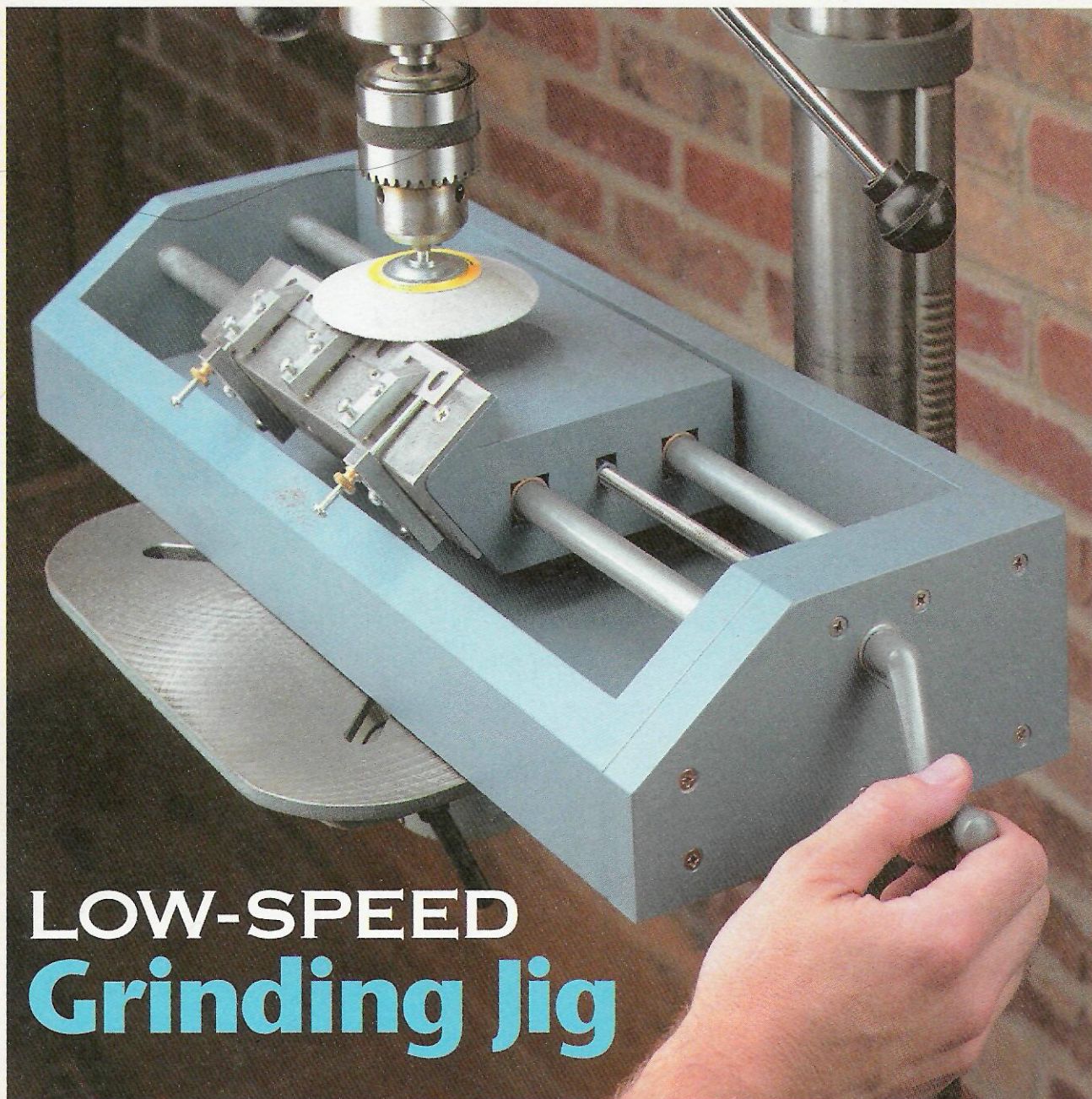

LOW-SPEED Grinding Jig

- Compound Miter Saw Test
- Tapping Threads
- Working with Shellac
- Miter Saw Work Station



ShopNotes®

Issue 31 January 1997

PUBLISHER Donald B. Peschke
EDITOR Tim Robertson
ASSOCIATE EDITOR Phil Totten
ASSISTANT EDITOR Bryan Nelson
ART DIRECTOR Cary Christensen
SR. GRAPHIC DESIGNER Kurt Schultz
SENIOR ILLUSTRATORS Roger Reiland
 Mark Higdon

CREATIVE RESOURCES

Creative Director: Ted Kralicek • *Project Developer:* Ken Munkel • *Project Designer:* Ted Wong • *Shop Mgr.:* Steve Curtis • *Shop Craftsman:* Steve Johnson • *Photography Dir.:* Lark Smotherman • *Sr. Photographer:* Crayola England

BOOKS

Executive Editor: Douglas L. Hicks • *Art Director:* Linda F. Vermie • *Sr. Graphic Designer:* Chris Glowacki

CIRCULATION

Circ. Dir.: Susan DuBois • *Direct Mail Mgr.:* Glenda Battles • *Sub. Mgr.:* Sandy Baum • *Renewal Mgr.:* Paige Rogers • *Asst. Direct Mail Mgr.:* Julie Greenlee • *Asst. Sub. Mgr.:* Joy Krause • *Assoc. Graphic Design Dir.:* Susie Rider • *Sr. Graphic Designer:* Cheryl L. Simpson

CORPORATE SERVICES

Vice Pres. of Planning & Finance: Jon Macarthy • *Controller:* Robin Hutchinson • *Sr. Accountant:* Laura Thomas • *Accts. Payable Clerk:* Mary Schultz • *Prod. Dir.:* George Chmielarz • *Elect. Pub.:* Douglas M. Lidster • *Prod. Asst.:* Susan Dickman • *Prod. Artist:* Jon Snyder • *Pre-Press Image Spec.:* Troy Clark • *Elect. Comm. Coord.:* Gordon C. Gaippe • *Net. Admin.:* Al Barnes • *Prof. Develop. Dir.:* Joyce Moore • *Human Res. Asst.:* Kirsten Koele • *Admin. Asst.:* Julia Fish • *Recept.:* Jeanne Johnson, Sheryl Ribbey • *Bldg. Maint.:* Ken Griffith

MAIL ORDER

Operations Dir.: Bob Baker • *Art Dir.:* Cindy Scarpino • *Mat'l's Mgr.:* Mark Mattiussi • *Cust. Service Mgr.:* Jennie Enos • *Nat'l. Sales Mgr.:* Kent A. Buckton • *Warehouse Supr.:* Nancy Johnson • *Buyer:* Linda Jones • *Op. Asst.:* Tammy Aldini • *Promotions Copywriter:* Dave Stone • *Team Leader:* Karla Eslinger • *Tech. Rep.:* Matthew TeRonde • *Cust. Service Reps.:* Jennifer Murphy, Anna Cox, Margo Petrus, Tammy Truckenbrod, William Nelson, Nancy Downey • *Warehouse:* Chuck Carlson, Sylvia Carey, Larry Prine, Scott Gilliam, Thomas Russell

ShopNotes® (ISSN 1062-9696) is published bimonthly (Jan., March, May, July, Sept., Nov.) by August Home Publishing, 2200 Grand, Des Moines, IA 50312.

ShopNotes® is a registered trademark of August Home Publishing ©Copyright 1997 by August Home Publishing. All rights reserved.

Subscriptions: Single copy: \$4.99. One year subscription (6 issues), \$24.95. Canada/Foreign add \$5 per year.

Periodicals Postage Paid at Des Moines, IA and at additional mailing offices.

Postmaster: Send change of address to ShopNotes, P.O. Box 37103, Boone, IA 50037-2103.

Subscription Questions? Write to: ShopNotes Customer Service, P.O. Box 842, Des Moines, IA 50304-9961. Or call 1-800-333-5854, 8:00 am to 5:00 pm, Central Time, weekdays. FAX 515-283-0447

E-Mail: ShopNotes@aol.com

Internet: http://www.augusthome.com

Reprinted 2002

PRINTED IN U.S.A.

WoodNet™

NOW ON THE WEB!

- 50 Woodworking Tips Online
- Woodworking Techniques — Step-by-Step
- Project plans you can download
- WoodNet Forum — Woodworkers' Q & A
- Power Tool Reviews

Point your browser to: <http://www.augusthome.com>
 Select "Woodworking" from the Welcome Page menu.

EDITOR'S NOTE

Cutoffs

The jointer knives looked like a hopeless case. Large nicks left tell-tale ridges behind. And the knives were so dull, they tore out big hunks of wood.

Usually, this would mean sending the knives out to a professional sharpening shop. But not this time.

GRINDING JIG. Instead, we decided to see if the low-speed grinding jig that Ken (our project developer) had been working on could restore the edge on these beat-up knives.

At first, there were quite a few skeptics. Why would you want to mount a grinding jig on the drill press anyway? And what was the deal with this strange-looking grinding disk and a hand crank that was "borrowed" from a window?

Rather than answer these questions, Ken just grinned and switched on the drill press. Then he turned the crank very deliberately as if he was slowly taking up line on a fishing reel.

To make a long story short, the grinding jig was a success. Not only did the bevel on each knife have a nice, even grind without a trace of a burn mark. But when we reinstalled the knives, they produced perfectly flat, smooth surfaces. (And that's no fish story.)

If you plan to build this grinding jig, there's a complete set of plans beginning with the article on page 16. We've also included some tips from our shop that will make it easy to work with some of the metal parts on this project.

SHOP SOLUTIONS. But you won't find these tips in the article itself. That's because even if you don't build the grinding jig, there's a good chance you'll find them useful on another project you're building. So we've put these tips together in *Shop Solutions* (page 30) so they're in one convenient place.

And speaking of tips, we're still publishing tips from our readers as always. You can find them starting on page 4.

Tim

STATEMENT OF OWNERSHIP, MANAGEMENT AND CIRCULATION (Required by 39 U.S.C. 3685)

- Title of Publication: ShopNotes. 2. Publication No.: 1062-9696. 3. Filing Date: September 25, 1996. 4. Issue Frequency: Bimonthly. 5. No. of issues published annually: 6 (six). 6. Annual subscription price: \$19.95. 7. Complete mailing address of known office of publication: 2200 Grand Avenue, Des Moines, (Polk County), Iowa 50312-5306. 8. Complete mailing address of the headquarters or general business offices of the publisher: 2200 Grand Avenue, Des Moines, (Polk County), Iowa 50312-5306. 9. Full names and complete mailing addresses of publisher, editor, and managing editor: Publisher: Donald B. Peschke, 2200 Grand Avenue, Des Moines, Iowa 50312; Editor: Tim Robertson, 2200 Grand Avenue, Des Moines, Iowa 50312. 10. Owner: August Home Publishing Company, 2200 Grand Avenue, Des Moines, Iowa 50312; Donald B. Peschke, 2200 Grand Avenue, Des Moines, Iowa 50312. 11. Known bondholders, mortgagees, and other security holders owning 1 percent or more of total amount of bonds, mortgages or other securities: None. 12. (Does not apply.) 13. Publication Title: ShopNotes. 14. Issue Date for Circulation Data Below: July 1996 (#28) 15. Extent and nature of circulation:

	Average no. copies each issue during preceding 12 months	Average no. copies of single issue published nearest to filing date
A. Total no. copies (net press run).....	215,279	202,304
B. Paid and/or requested circulation:		
1. Sales through dealers, street vendors and counter sales.....	18,274	15,431
2. Mail subscriptions (paid and/or requested).....	158,988	149,877
C. Total paid and/or requested circulation.....	177,262	165,308
D. Free distribution by mail, samples, complimentary, and other free copies.....	58	72
E. Free distribution outside the mail (carriers or other means).....	0	0
F. Total free distribution.....	58	72
G. Total distribution.....	177,320	165,380
H. Copies not distributed:		
1. Office use, left over, unaccounted, spoiled after printing.....	7,911	10,176
2. Returns from news agents.....	30,048	26,748
I. Total.....	215,279	202,304
Percentage Paid and/or requested circulation.....	99.97%	99.96%
16. This statement of ownership will be printed in the Jan. 1997 (#31) issue of this publication.		
17. I certify that the statements made by me above are correct and complete. (signed) Tim Robertson, Editor		

Contents

Projects & Techniques

Miter Saw Station _____ 6

This miter saw station will spoil you. When you raise the folding wings, two extension tables provide all the support you need for cutting long workpieces. And with a flip-up stop block that slides along a fence, you can make precision cuts without measuring and marking.

Miter Saw Tune-Up _____ 14

It's easy to keep your power miter saw running smoothly and accurately. All it takes is some routine maintenance and a few basic adjustments.

Low-Speed Grinding Jig _____ 16

You can get razor sharp edges on your plane irons and jointer knives with this shop-built grinding jig. Along with a grinding wheel that's chucked in the drill press and spinning at low speed, it gives you complete control over every step of the grinding process.

Departments

Tips & Techniques

Readers' Tips _____ 4

Our readers offer their own shop-tested tips: Magnetic Resaw Fence, Leg Leveler, String Clamp, Speed Control, and a tip for Hanging Full-Overlay Doors.

Selecting Tools

Compound Miter Saws _____ 24

Thinking about buying a compound miter saw? Our three-man team tests four popular models and offers practical suggestions on the best one to buy.

Finish Room

Shellac _____ 28

Shellac has been around for years — and there's a good reason for it. Besides providing plenty of protection, it's extremely easy to apply. This "old timer" also provides solutions to many modern finishing problems.

Tips From Our Shop

Shop Solutions _____ 30

Whether you're building the projects in this issue or another one altogether, this collection of tips from the guys in our shop is sure to come in handy.

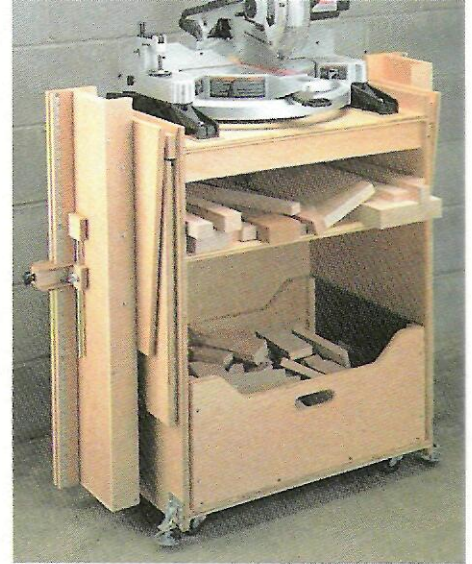

Miter Saw Station page 6

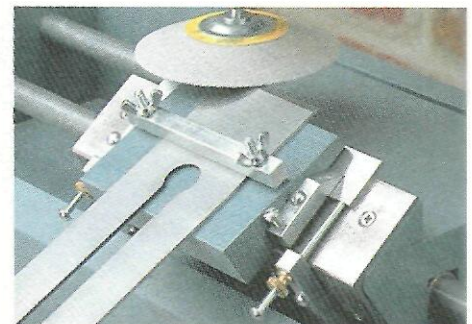

Grinding Jig page 16

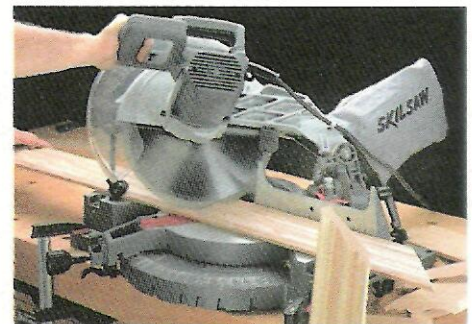

Miter Saws page 24



Shellac page 28

Readers' Tips

Magnetic Resaw Fence

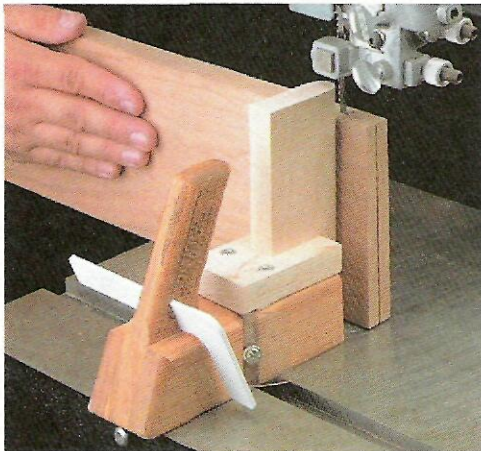

■ When resawing on the band-saw, it can be difficult clamping a fence in place because of the support ribs under the table. And it's time consuming if you need to reposition the fence to compensate for the drift of the blade.

To eliminate the clamps altogether and make it easy to adjust for drift, I made a magnetic resaw fence that can be positioned quickly anywhere on

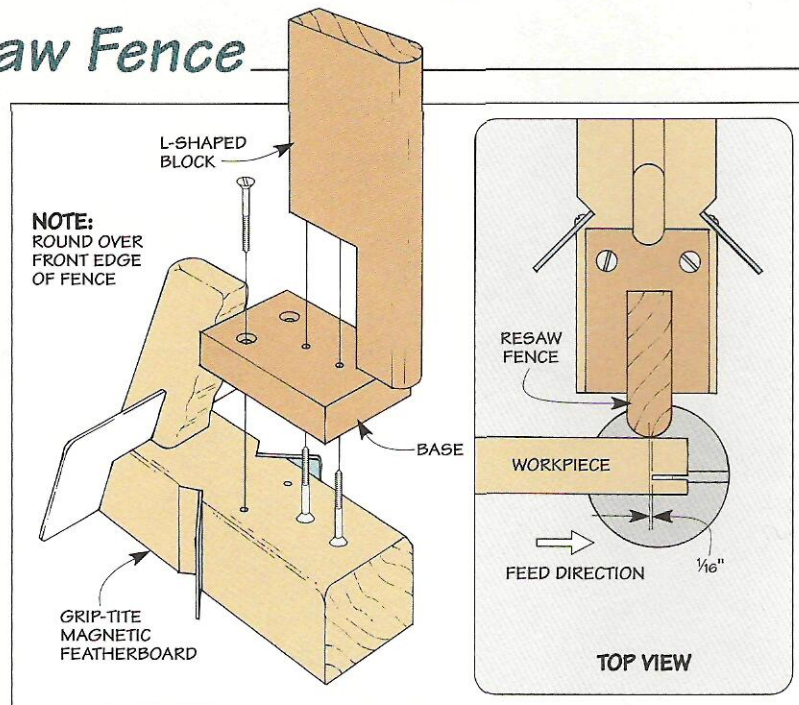

the table, see photo. It's just an L-shaped block screwed to a base piece, see drawing. This assembly is screwed to my *Grip-Tite* magnetic featherboard.

A roundover routed on the front edge of the fence lets you

“swing” the workpiece to one side or the other to adjust for drift. Note: To make this work, position the centerpoint of the fence $\frac{1}{16}$ " ahead of the blade.

Thomas Kabelitz
Long Beach, California

Mounting Full-Overlay Doors

■ Sometimes it takes a lot of fiddling around to get an even gap between two full-overlay doors. So I use a simple technique to establish a consistent gap.

Start by screwing the hinges to the doors. Then slip a steel rule (mine is $\frac{3}{32}$ " thick) between the doors and clamp them together, see drawing.

To raise the pipe clamps above the rule (and to protect the doors), I've added an oversized clamp pad to each jaw. It's just a scrap with a hole to fit the pipe.

Gerald Kunkel
Merrill, Wisconsin

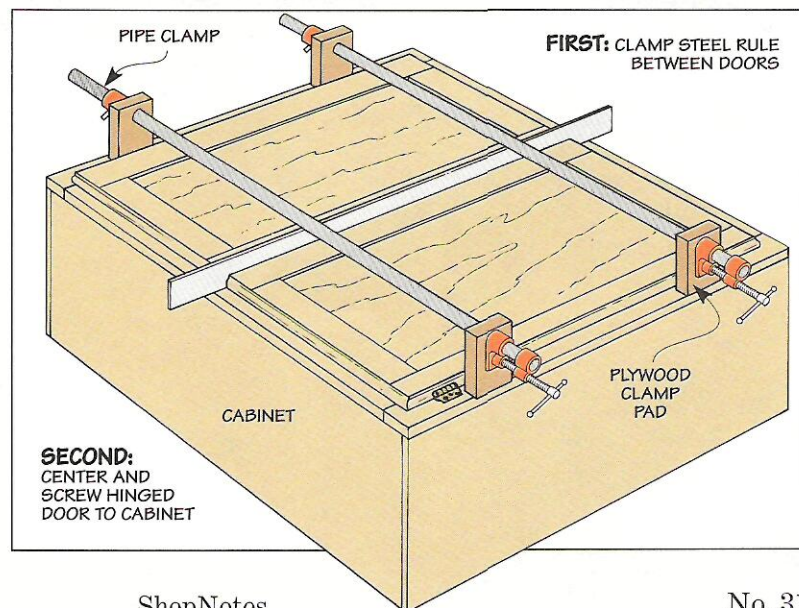

Leg Leveler

■ Here's a handy leg leveler I use on my shop-made tool stands. The thing that's unusual about this leveler is it has a rubber tip on the bottom. This keeps the stand from "walking" across the floor of the shop if there's any vibration produced by the tool.

The rubber tip is nothing more than the pad from the bottom end of a crutch. (I picked one up at a local hardware store for about 75 cents.)

The crutch tip fits over a dowel that has a hole drilled in it to accept a carriage bolt, see drawing above. After slipping on a washer and nut, the bolt threads into a T-nut installed in the bottom of the leg. Note: To provide

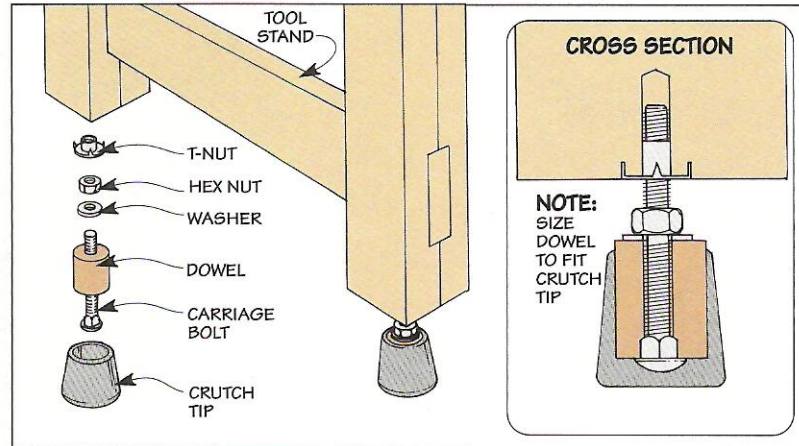

clearance for the bolt as you adjust the leveler, you'll need to drill a deep shank hole for the T-nut.

The only thing to keep in mind when using the leveler is the nut

has to be tight. This keeps the dowel from spinning as you adjust the leveler.

Brad Mege'
Marietta, Georgia

String Clamp

■ The small number of picture frames I make doesn't justify the cost of a special frame clamp. So I use a nylon string and some scraps of wood instead.

To apply clamping pressure, tie the string tightly around the frame and place the blocks in between, see drawing. To draw the miters together, just slide the scraps toward the corners. Note: A kerf in each block keeps the string from slipping off.

A. J. Gauthier
Parnell, Missouri

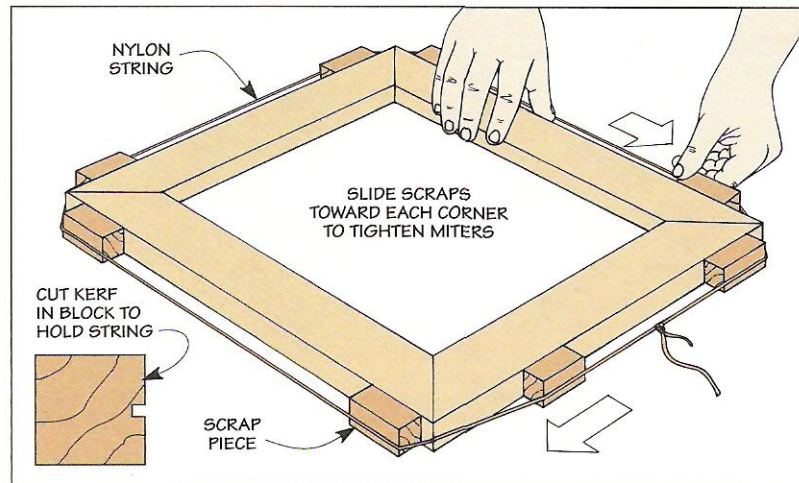

Speed Control



■ The speed on my sabre saw is determined by the amount of pressure on the trigger. But with the trigger locked in the "on" position, the blade only runs at high speed.

To adjust the speed when the saw is mounted upside down in my sabre saw table, I slip on a hose clamp and tighten (or loosen) it as needed.

Joe Xaver
Warners, New York

Send in Your Solutions

If you'd like to share your original solutions to problems you've faced, send them to: *ShopNotes*, Attn.: Shop Solutions, 2200 Grand Avenue, Des Moines, IA 50312. (Or if it's easier, FAX them to us at: 515-282-6741.)

We'll pay up to \$200 depending on the published length. Please include a daytime phone number so we can call you if we have any questions.

Miter Saw Station

*It's the large wingspan that you notice.
But it's a system for cutting pieces to
length without measuring and marking
that makes this miter saw station unique.*

Stop Block. There's no need to measure and mark to cut a workpiece to length. Just slide a stop block along the fence until it lines up with the correct mark on the tape measure (left). Then flip it up to "save" the setting or to cut a longer workpiece (right).

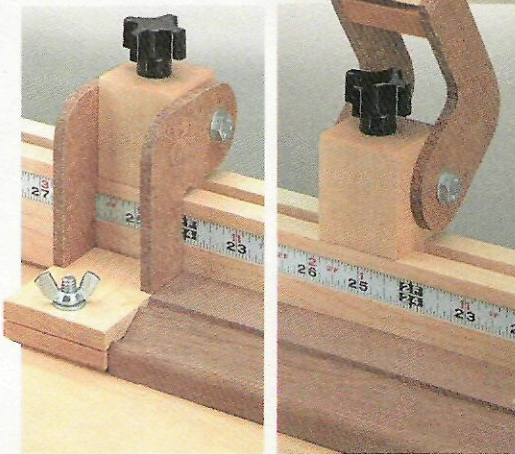

Wings up.
Flaps out.

Levelers down. No, it wasn't a lesson on how to fly an airplane. It was just Phil (our associate editor) explaining how this miter saw station worked.

The "wings" he was talking about are really the underpinnings for two long extension tables, see photo above. With the miter saw mounted to a center cabinet, the tables provide sturdy support on each side when you're cutting long workpieces to length.

FENCE & STOP BLOCK. But there's a lot more to these tables than just holding up a workpiece. Each table has a built-in fence with an adjustable stop block, see photos at left. Along with a tape measure on each fence, the stop block lets you cut a workpiece to length without having to measure and mark.

Regardless of the speed and accuracy this provides, the long extension tables would just be in the way when you're not using the miter saw. Especially when you consider that they have an overall "wingspan" of nearly eight feet.

FOLDS DOWN. So to save space and avoid bumping into the tables, they fold down when you're done using the saw, see bottom photo at left. This creates a compact tool stand that you can roll out of the way for storage or out to the driveway to tackle the next job.

BIN & SHELF. Wherever you happen to be working, there's bound to be a lot of cutoffs. But you don't need to throw them on the floor. That's because there's a removable scrap bin on the bottom. And if you're working with a number of pieces, there's a simple shelf to hold them until you're ready to start cutting.

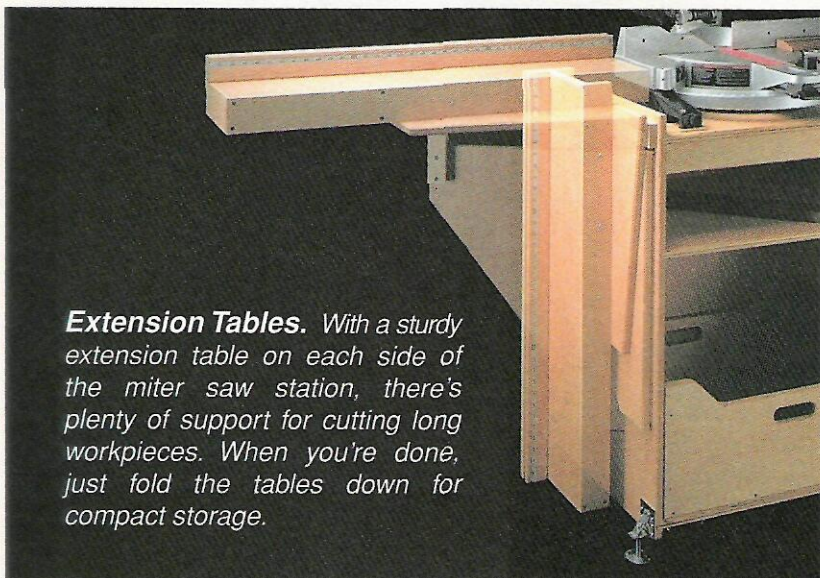

Extension Tables. With a sturdy extension table on each side of the miter saw station, there's plenty of support for cutting long workpieces. When you're done, just fold the tables down for compact storage.

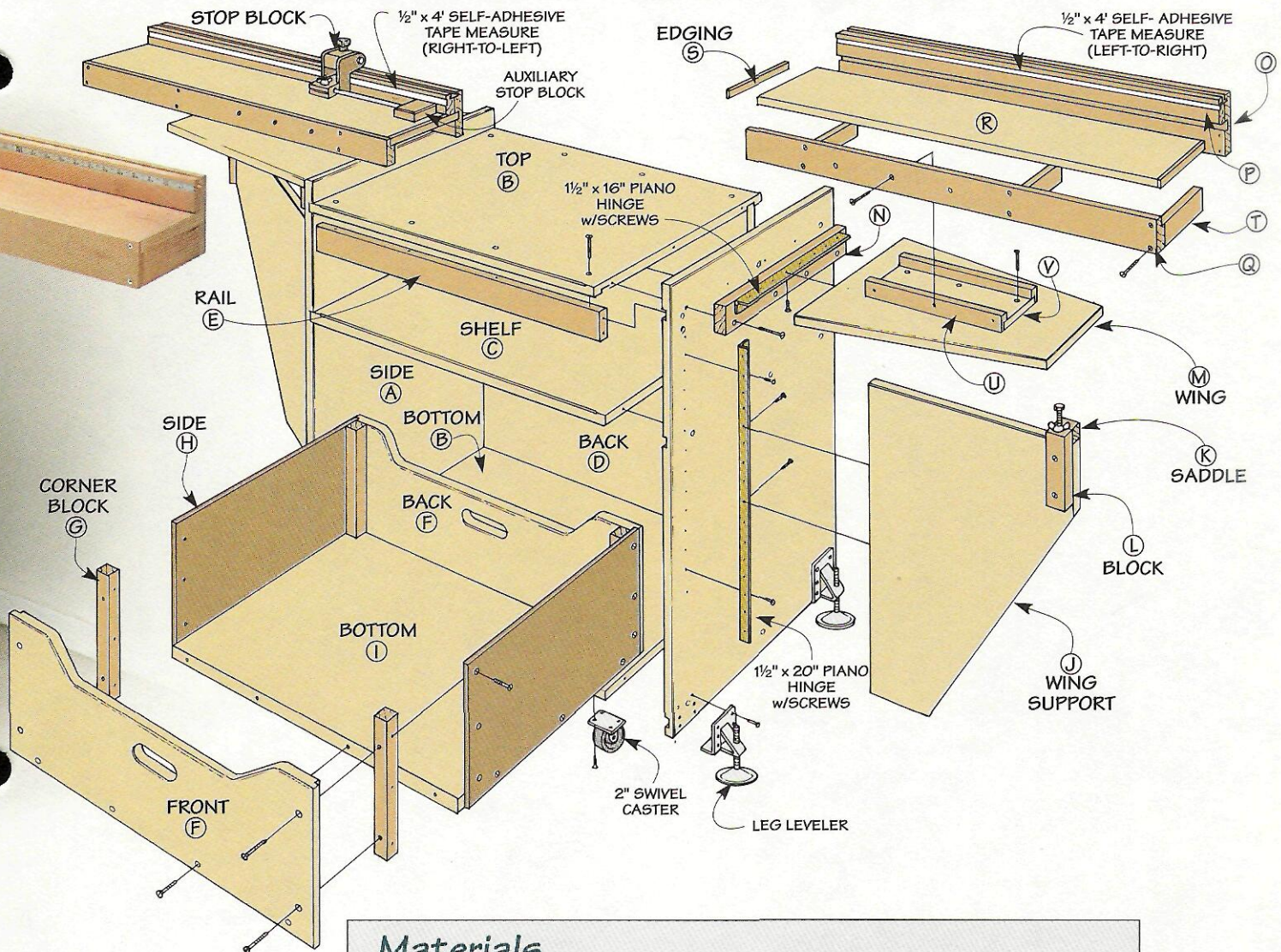

EXPLODED VIEW
OVERALL DIMENSIONS:
43 1/2" H x 96 1/4" W x 21" D

Materials

Case

- A Sides (2) 21 x 34³/₄ - ³/₄ Ply.
- B Top/Bottom (2) 21 x 27 - ³/₄ Ply.
- C Shelf (1) 19⁵/₈ x 27 - ³/₄ Ply.
- D Back (1) 26¹/₄ x 31¹/₂ - ³/₄ Ply.
- E Rail (1) 3 x 26¹/₄ - ³/₄ Ply.

Scrap Bin

- F Front/Back (2) 11 x 26 - ³/₄ Ply.
- G Corner Blocks (4) ³/₄ x ³/₄ - 10¹/₄
- H Sides (2) 11 x 18⁷/₈ - ¹/₄ Hardboard
- I Bottom (1) 18⁷/₈ x 25¹/₂ - ³/₄ Ply.

Table Supports

- J Wing Supports (2) 19 x 23 - ³/₄ Ply.
- K Saddles (2) ³/₄ x 1¹/₂ - 1
- L Blocks (2) ³/₄ x 1¹/₂ - 4
- M Wings (2) 17¹/₂ x 20¹/₂ (rgh.) - ³/₄ Ply.
- N Cleats (2) ³/₄ x 2 - 17¹/₄

Extension Tables

- O Back Fences (2) ³/₄ x 4³/₄ - 36
- P Front Fences (2) ³/₄ x 2 - 36
- Q Rails (2) ³/₄ x 2⁵/₈ - 36
- R Beds (2) 7¹/₄ x 35¹/₂ - ³/₄ Ply.
- S Edging (4) ¹/₄ x ³/₄ - 7¹/₄
- T Stretchers (6) ³/₄ x 2 - 6¹/₂
- U Sides (4) ³/₄ x 1³/₄ - 14¹/₂
- V Mounting Plates (2) 5³/₄ x 14¹/₂ - ³/₄ Ply.

Stop Block

- W Arms (2) 3 x 3⁵/₈ - ¹/₄ Hardboard
- X Clamp Head (1) 1¹/₂ x 1¹/₂ - 2
- Y Stops (2) ³/₄ x 2 - 2¹/₂

Hardware

- (4) 2" Swivel Casters
- (4) Heavy-Duty Leg Levelers
- (40) #10 x ³/₄" Ph Sheet Metal Screws
- (12) #8 x 1¹/₄" Ph Sheet Metal Screws
- (12) #8 Flat Washers
- (5) ¹/₄" Flat Washers
- (16) ¹/₄" Lock Washers
- (9B) #8 x 1¹/₄" Fh Woodscrews
- (8) #8 x 2" Fh Woodscrews
- (18) #8 x ³/₄" Fh Woodscrews
- (2) 1¹/₂" x 36" Piano Hinge w/screws
- (2) ¹/₄" x 2" Full-Thread Hex Bolts
- (1) ¹/₄" x 2¹/₂" Hex Bolt
- (1) ¹/₄" x ³/₂" Toilet Bolt
- (1) ¹/₄" x 1" Carriage Bolt
- (2) ¹/₄" Threaded Inserts
- (1) ¹/₄" Lock Nut
- (3) ¹/₄" Wing Nuts
- (1) ¹/₄" Plastic Knob
- (1) 4" Tape Measure (Left-to-Right)
- (1) 4" Tape Measure (Right-to-Left)
- (1) ³/₁₆" x 11⁷/₈" Steel Rod

ShopNotes Project Supplies is offering a kit for the saw station (Kit, No. 6831-100) that includes the leg levelers, tape measures, and all the hardware you need to build the stop block. Call 800-347-5105 for availability and pricing.

Case

I started on the miter saw station by making the case. Basically, it's an open plywood box with a recessed top to support the miter saw. An opening in the bottom holds a scrap bin, see drawing. And a shelf below the top provides a handy place to put workpieces that you're not ready to use yet.

SIDES. I began work on the case by making two sides (A), see Fig. 1. They're held together with a top/bottom (B) and a shelf (C) that fit in dadoes in the sides, see details 'a' and 'd.'

These pieces are all cut to the same length (27"). But to allow for a back (added later) that's set in just a bit, the shelf is narrower than the top and bottom.

Since the width of the shelf is easier to determine *after* the case is assembled, I set it aside and ripped the top and bottom to final width (21").

GROOVES. Before assembling the case, you'll need to cut a groove for a rail (E) (added later) near the front edge of the top only, see detail 'c.' And there's a groove near the back edge of the top *and* bottom for the back of the case, see detail 'b.'

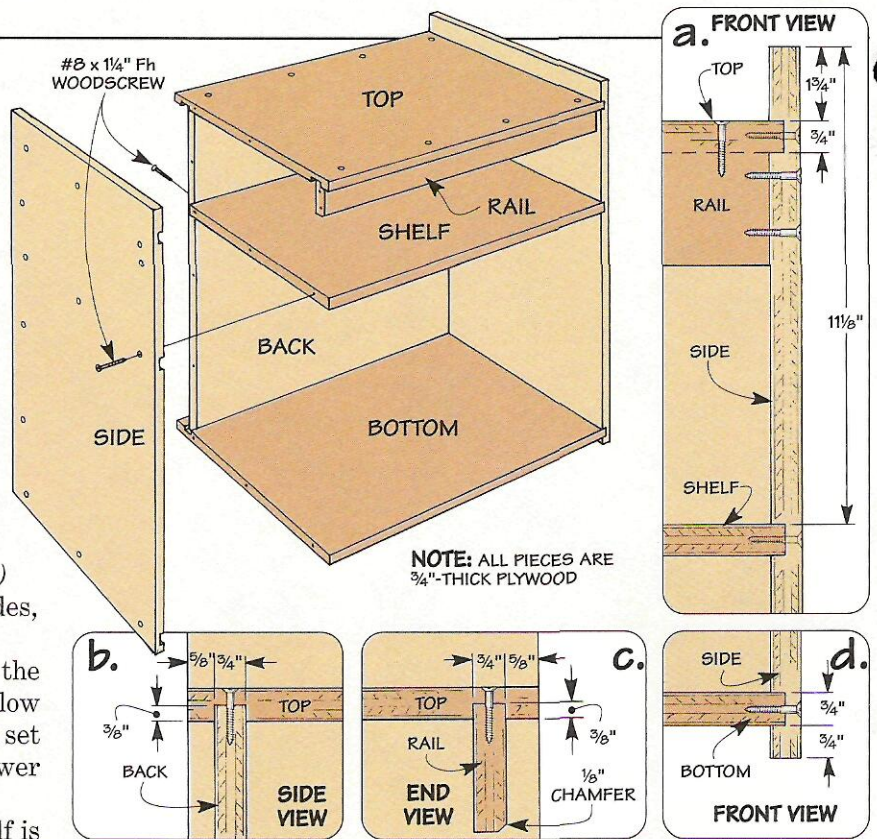

BACK. To determine the size of the back (D), it's easiest to dry assemble the case, see Fig. 1. While the back is cut to fit between the grooves in the top and bottom, it simply butts against the sides.

ASSEMBLY. Because of this, the easiest way I found to assemble the case is to first glue up a U-shaped assembly that

consists of one side and the top and bottom, see Fig. 1. Then slide the back into place and add the other side. Reinforcing each of the glue joints with screws helps strengthen the case.

Once the case is assembled, you can trim the shelf to final width and glue and screw it to the sides, see Fig. 2. To add rigidity to the top, I added a rail (E).

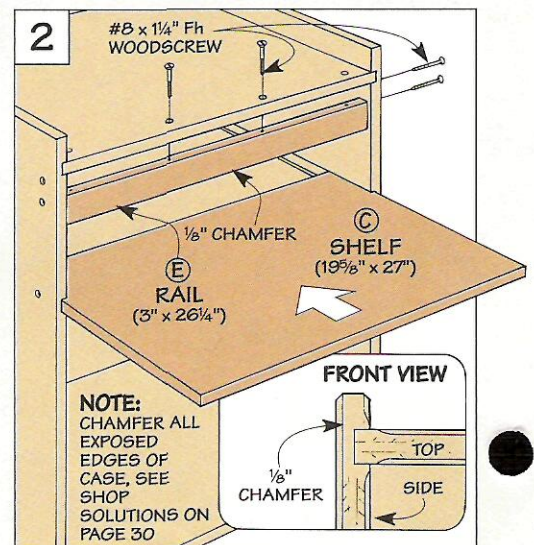
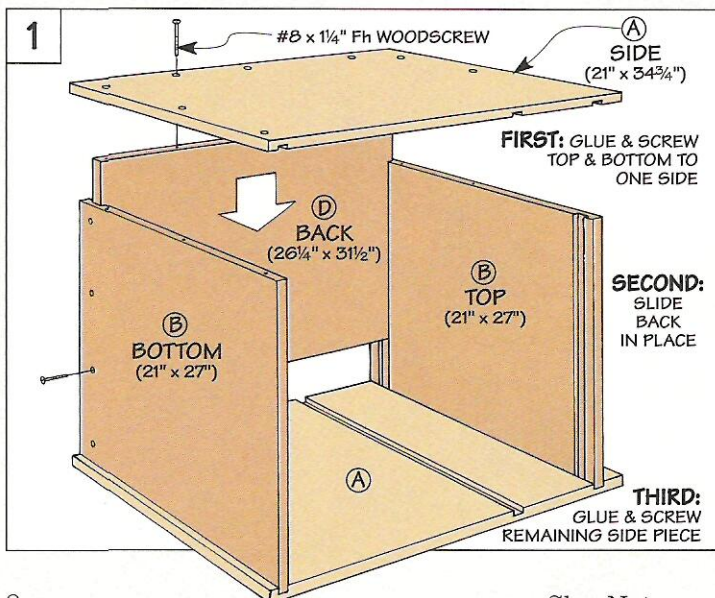

After chamfering the bottom edge, it's glued and screwed to the case.

CASTERS & LEVELERS. Finally, to make it easy to roll the miter saw station around, I mounted four casters to the bottom, see Fig. 3. But I didn't want it to move around when making a cut.

So I added four leg levelers to raise the casters off the floor, see margin. When working with long or heavy pieces, these levelers provide a solid foundation for the miter saw station.

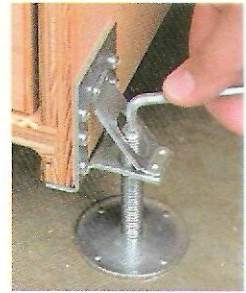
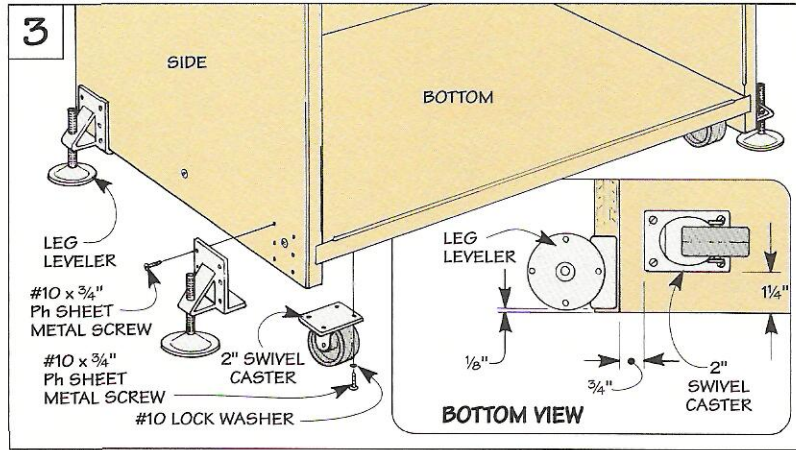

Use an Allen wrench to adjust each leveler and raise the miter saw station off its casters.

Scrap Bin

To keep my work area clear of cutoffs, I added a removable scrap bin, see Fig. 4.

I wanted this bin to be sturdy, yet light enough that it's not a chore to empty. So it's made up of a combination of plywood, hardwood, and hardboard.

FRONT & BACK. The front and back (F) are pieces of 3/4"-thick plywood that are cut to length to allow an 1/8" gap at each side. Narrow rabbets in each end accept

the sides of the bin, see Figs. 4b and 5. And there's a wide rabbet in the bottom edge for the bottom.

CUTOUTS. To improve my shooting percentage when I toss scraps into the bin, I cut a large opening in the top edge of the front and back, see Fig. 4a. Also, a simple handhold makes it easy to carry the bin to the firewood pile.

CORNER BLOCKS. Next, to help strengthen the corners, I added four corner blocks (G), see Fig.

5. These are pieces of hardwood glued and screwed to the front/back so they're flush with the rabbets.

SIDES. With the corner blocks in place, you can add the sides (H), see Fig. 4. To reduce the weight of the bin, the sides are made from pieces of 1/4" hardboard that are glued and screwed to the corner blocks.

Finally, a plywood bottom (I) is cut to fit, then glued and screwed in place, see Fig. 4.

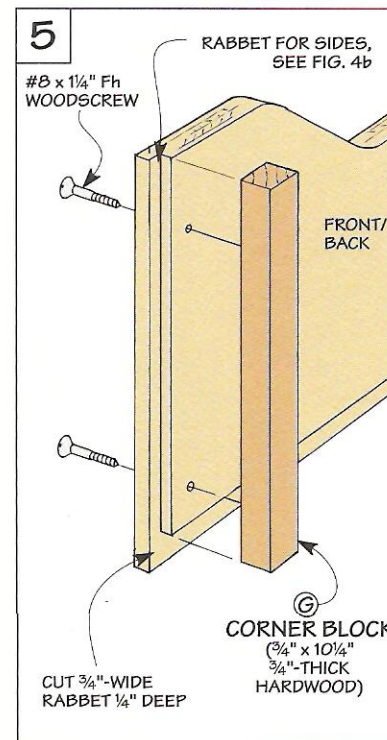
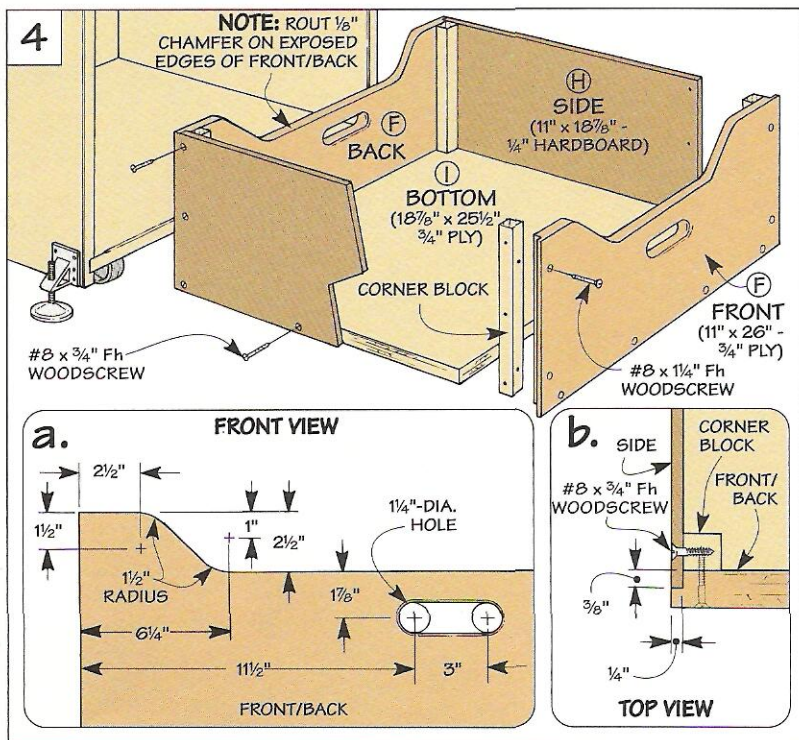

Table Supports



To avoid crushing the hinge when you tighten it in a vise, slip a thin scrap between the leaves, then cut it to length.

With the case complete, I added two plywood supports to each side. A wedge-shaped wing serves as a platform for the extension table, see drawing. And a triangular-shaped support props up the wing.

WING SUPPORTS. Each wing support (J) is attached to the side of the case with a piano hinge, see Fig. 6. This way, you can swing it out to hold up the wing. Or fold it flat for storage.

The easiest way to attach the hinge is to first screw one leaf to the wing support. Then mount the assembly to the case. To provide clearance for a cleat (added later), the wing support is 2 7/8" from the top. And it's flush at the front when it's fully opened, see Fig. 6a.

LEVELERS. Next, I added two levelers to adjust the height of the wings. Each one consists of two glued-up blocks: a saddle (K) that fits over the support and a block (L) that houses an adjustment mechanism, see Fig. 7.

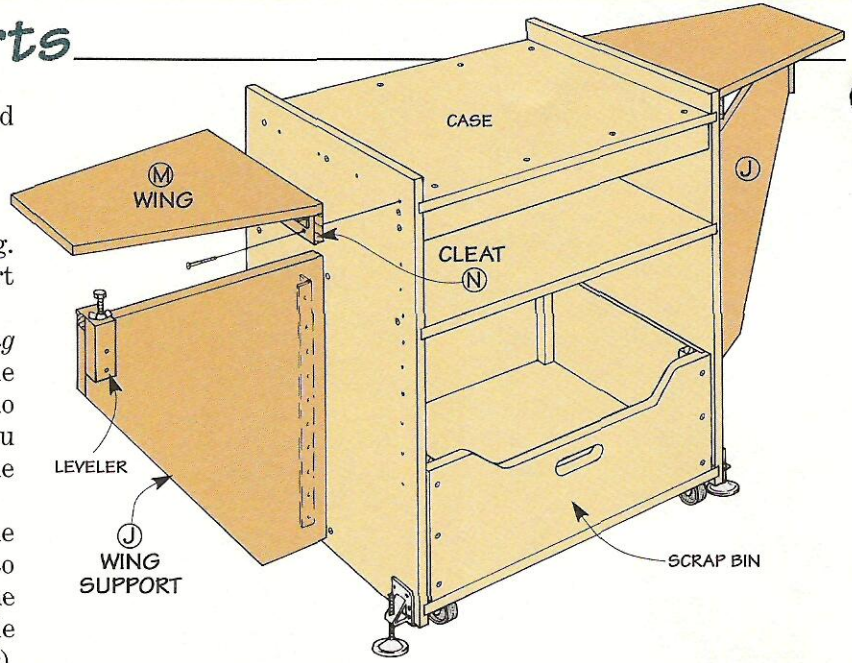

The key to this mechanism is a simple bolt. As you thread it in (or out) of an insert in the end of the block, the head of the bolt lowers (or raises) the wing. Tightening a wing nut locks in the adjustment.

WINGS. Now you can add the two wings (M), see Fig. 8. A shallow hole in the bottom of each wing creates a pocket for the bolt in

the leveler. This keeps the wing support from accidentally getting knocked out from under the wing.

ATTACH WINGS. To fold the wings up and down, they're also attached with a piano hinge. Here again, it's easiest to screw one leaf to the wing first. Then attach the other leaf to a hardwood cleat (N) that's glued and screwed to the case.

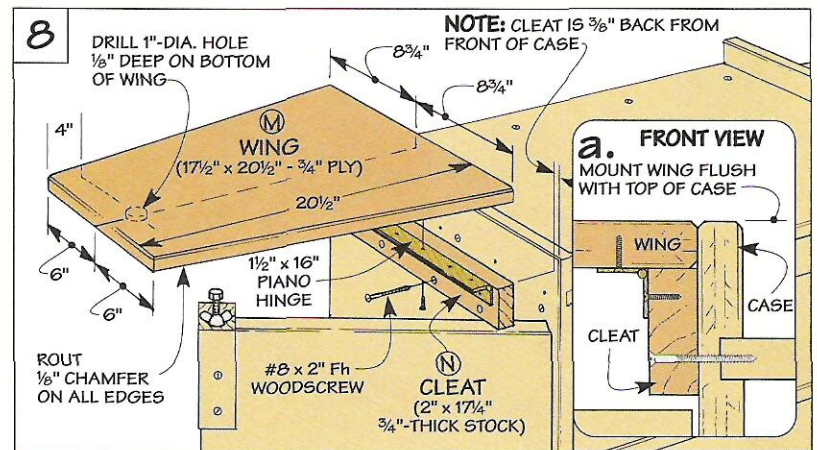
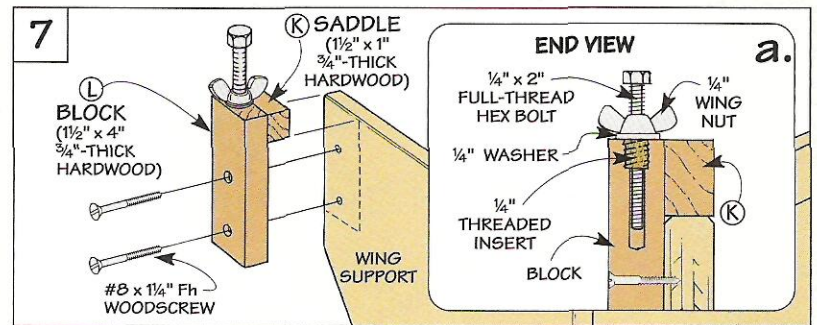
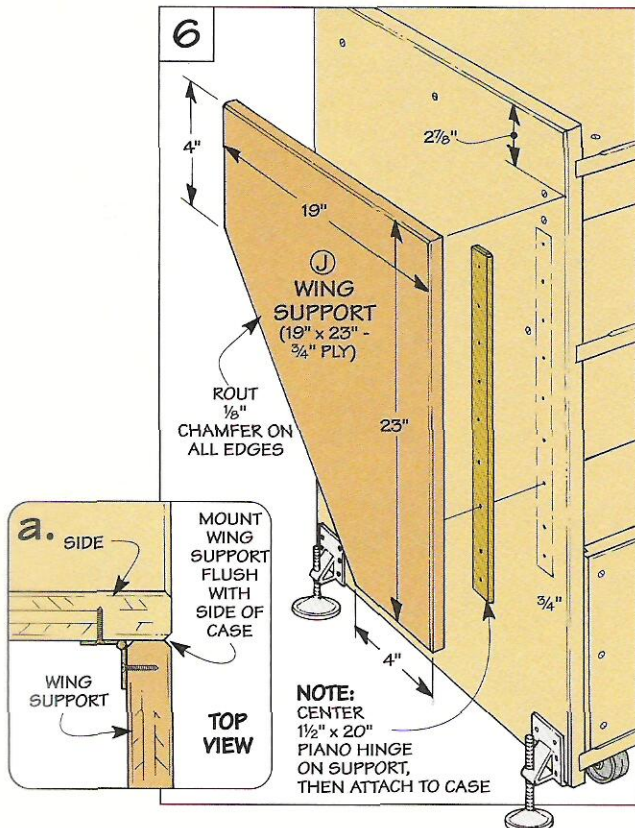

Extension Tables

With the table supports in place, you've laid the groundwork for the two extension tables, see Fig. 9. Besides supporting long workpieces, each table has a fence with a T-slot that acts as a track for an adjustable stop block.

FENCE. The fence on each table consists of two hardwood pieces: a tall *back fence* (O) and a short *front fence* (P), see Fig. 9. (I used maple.) After cutting the pieces to length (36") the T-slot is formed by making two simple cuts in each piece.

First, to accept the head of a toilet bolt, cut a narrow ($\frac{3}{16}$ ") groove near the top edge. Second, rabbet the inside edge of each piece for the shank of the bolt.

At this point, there are just a

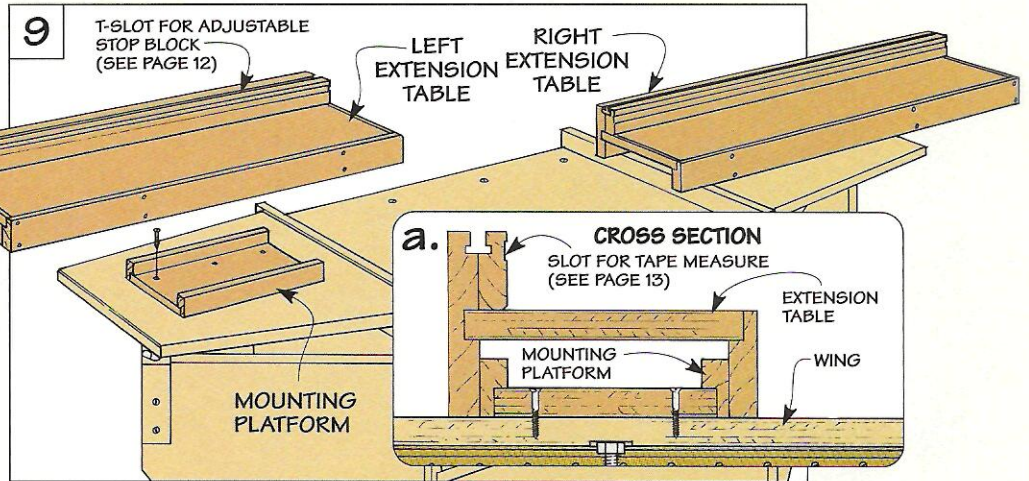

few things left to complete the front fence. A shallow groove cut in the front provides a recess for a tape measure. And the bottom edge is chamfered for dust relief.

The back fence isn't quite com-

plete yet either. Along with a *rail* (Q), it supports a plywood *bed* (R). The bed fits in a groove in the back fence and a corresponding rabbet in the rail. To end up with a bed that's flat, make sure the groove aligns with the rabbet.

ASSEMBLY. Now it's just a matter of putting all the pieces together. After gluing thin strips of hardwood *edging* (S) to the ends of the bed, it's glued and clamped between the back fence and rail. Then simply glue the front fence piece in place.

STRETCHERS. To complete each table, I added three hardwood *stretchers* (T), see Fig. 10. They work together with a mounting platform (added next) to position the tables on the wings.

One stretcher is screwed flush with the outside end of the table. But the stretcher at the end nearest the saw is set in $3\frac{1}{4}$ ". Along with the middle (offset) stretcher, it controls the side-to-side adjustment of the table.

MOUNTING PLATFORMS. That's where two U-shaped mounting platforms come in, see Fig. 11. They're just two hardwood *sides* (U) that are rabbeted to fit a plywood *mounting plate* (V). Later, they'll be attached to the wings, and the table will fit down over the platforms.

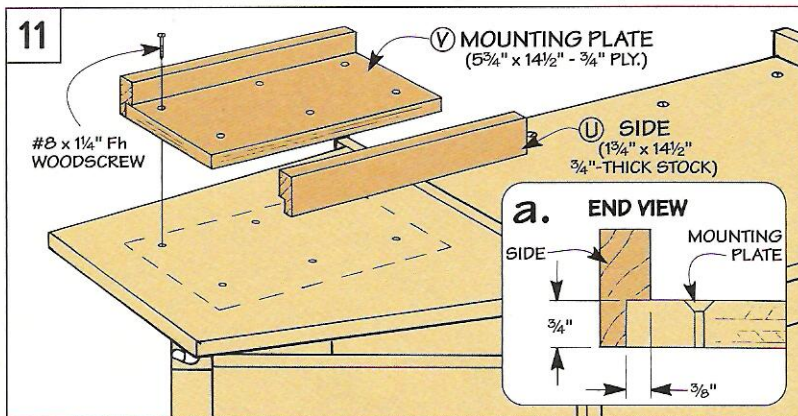
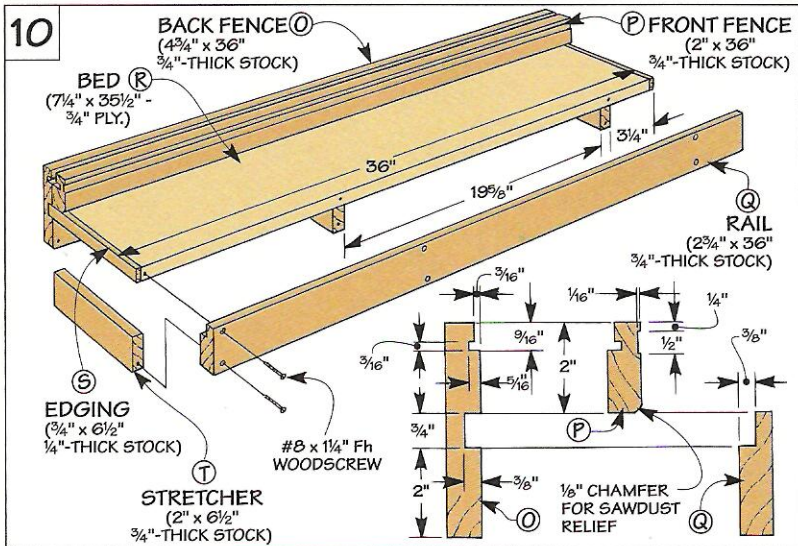

Stop Block

One of the handiest things about this miter saw station is a flip-up stop block. It consists of three parts: a pair of L-shaped arms, a clamp head that slides in the T-slot in the fence, and a block that acts as a stop, see Fig. 12.

ARMS. The clamp head and the stop are sandwiched between two identical arms (*W*), see Fig. 13. A hole drilled through the arms accepts a bolt that acts as a pivot when you flip up the stop.

CLAMP HEAD. The next step is to add the clamp head (*X*), see Fig. 14. It's a hardwood block with a centered tongue on the bottom that fits in the T-slot. When cutting the tongue, it's safest to start with an oversize blank and sneak up on the final thickness until it just fits the T-slot.

After cutting the clamp head to length, just drill a centered hole for the toilet bolt that slides

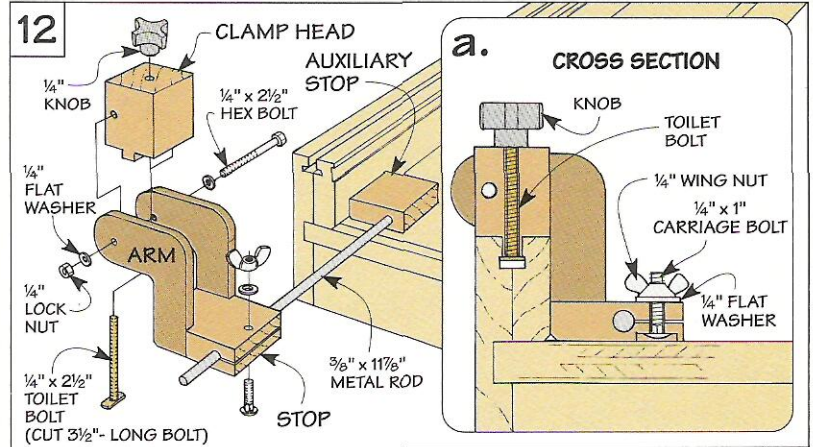

in the T-slot. Tightening a knob onto the bolt will lock the stop block in place, see Fig. 12a.

STOP. All that's left is to add the stop (*Y*), see Fig. 15. It's nothing more than a block with notches cut at one end to fit the arms.

To accept a metal rod that fits into an auxiliary stop (see margin), there's a hole drilled through the edges of the stop. This hole allows the rod to slide back and forth. But you'll still need a way to lock it in place.

This is just a matter of cutting a kerf in the end of the stop that will pinch down on the rod when you apply pressure. This pressure comes from tightening a wing nut on a bolt that passes through a hole in the end of the stop.

ASSEMBLY. All that's left now is to assemble the stop. After gluing the arms to the stop, chamfer the bottom edges of the stop block (and auxiliary block) for dust relief. Then drill a hole through the clamp head for the bolt, see Fig. 16.

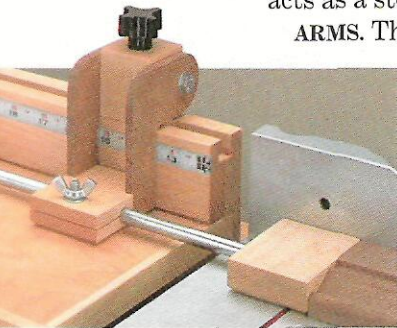

To cut short pieces, an auxiliary stop extends over the metal saw table. It's just a wood block that's held onto the end of a metal rod with epoxy.

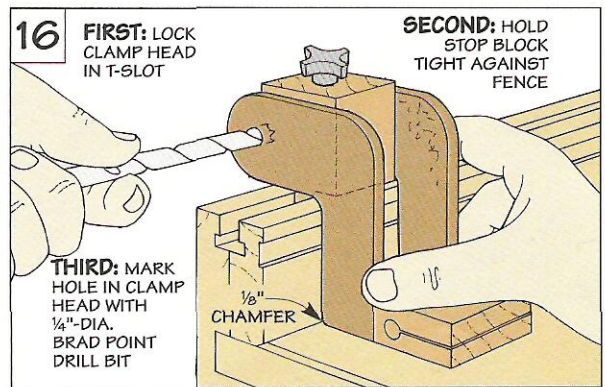
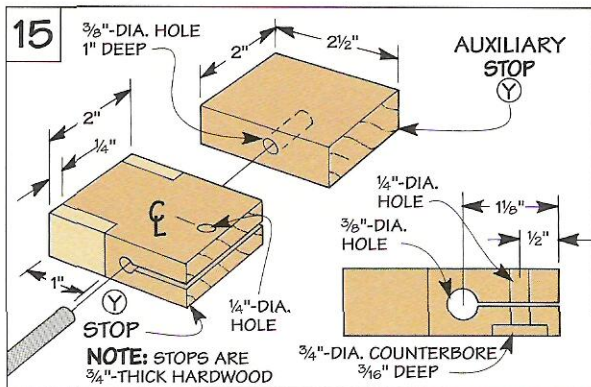
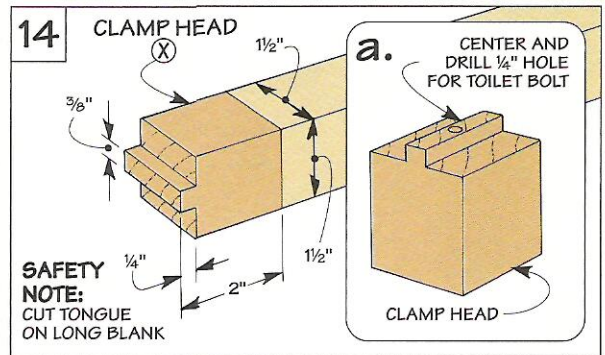
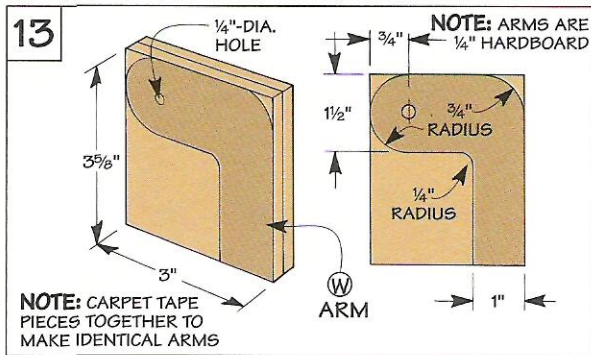

Setup

Before you can use the miter saw station, you'll need to take a few minutes to set it up.

LEVEL WINGS. To ensure that a workpiece will lay flat on the extension tables, the first step is to level the wings, see Step 1.

ATTACH PLATFORMS. Once the wings are level, you can attach the mounting platforms, see Step 2. Since these platforms determine the location of the fences, it's important that they line up.

INSTALL TABLES. After screwing the mounting platforms in place, you can install the extension tables. To do this, fit the tables down over the mounting platforms and slide them toward the miter saw, see Step 3. Note: To build in some side to side adjustment, the tables are attached to the mounting platforms with screws that pass through *oversize* holes.

MOUNT SAW. At this point, you can mount the miter saw to the top of the station. But before bolting it in place, you'll need to check that the metal table and fence of the saw are flush with the bed and fence on each extension table, see Step 4.

ADD TAPE MEASURES. All that's left is to apply a self-adhesive tape measure to each fence, see Step 5. (One reads right-to-left, the other left-to-right.)

An easy way to determine the position of the tape measures is to use a 12" scrap as a gauge, see Step 5.

After trimming the ends of the tape measures, you may still need to do some "fine tuning" to get accurate cuts. To do this, cut a test piece and compare its length with the location of the stop block on the tape measure. If you need to make an adjustment, just loosen the screws that hold the tables in place and nudge them one way or the other. 

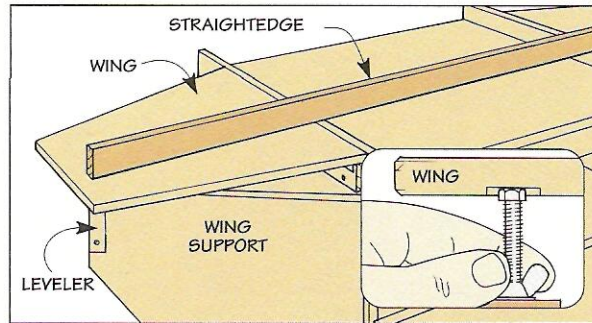

Step 1. Level Wings. With a straightedge set across the top of the miter saw station, adjust the bolt in the leveler to raise or lower the wings so they're flush with the bottom of the straightedge.

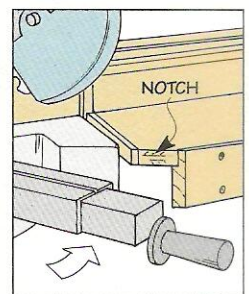

Depending on your saw, you may need to notch the inside corner of the extension table to provide clearance for the miter lock handle.

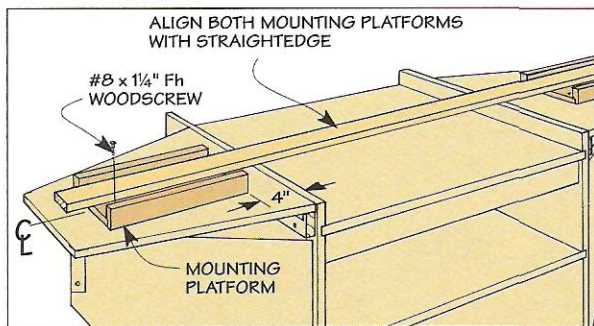

Step 2. Attach Mounting Platforms. To ensure the fences on the extension tables align, use the straightedge to align the two mounting platforms. Then screw the mounting platforms to the wings.

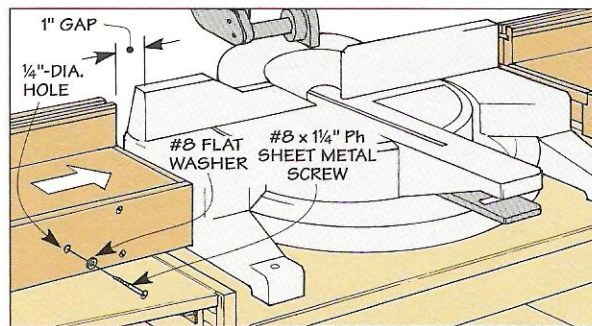

Step 3. Install Tables. After fitting the extension tables down over the mounting platforms, slide them into position next to the miter saw (I left a 1" gap). Then just screw the tables to the mounting platform.

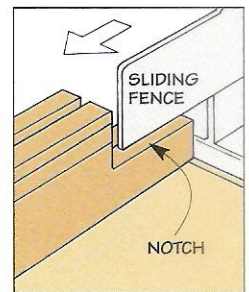

If your miter saw has a tall sliding fence, you'll need to notch the wood fence on the left-hand extension table.

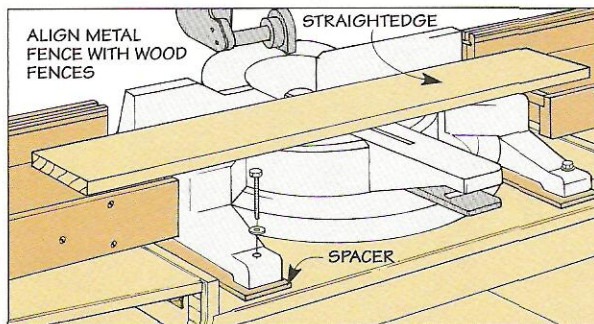

Step 4. Mount Saw. Before bolting the saw in place, use spacers (if needed) to raise the table flush with the bed of each extension table. Also, make sure that the metal fence aligns with the wood fences.

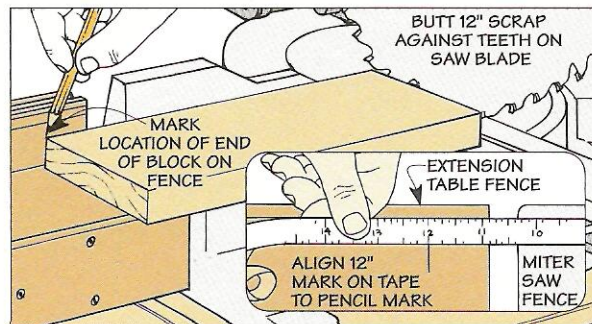

Step 5. Apply Tape Measure. To position the tape measure, butt a 12" scrap against the blade and make a mark on the fence. Then align the 12" increment on the tape with the mark and press it into place.

Miter Saw Tune-Up

All it takes is a quick tune-up to keep your miter saw running smoothly and accurately.

Let me get right to the point. We have a used power miter saw in the shop. And I mean it's used for everything. From projects in the shop and trimming out doors and windows. To building decks, porches, and all kinds of remodeling jobs in between.

The amazing thing about all this (other than the length of the waiting list to use the saw) is that it still provides accurate cuts. That's because we've made it a point to take care of the routine maintenance and make the minor adjustments that keep it running smooth.

CLEANING. Even something as simple as cleaning off sawdust, pitch and resin makes a difference. Especially around the moving parts of the saw that are difficult to operate if they're packed with dust.

INSPECT BRUSHES. You'll also want to remove the brushes that transfer electrical current to the motor and inspect them for wear, see detail 'a.' As the brushes wear, they get shorter. If they get too short (or if they're heavily scored), the motor will spark more than usual and bog down or stop altogether. To find out how long the brushes should be, check your owner's manual and replace them if necessary.

LUBRICATION. Another part of routine maintenance is to oil the main pivot points on the saw. (I use sewing machine oil.) Don't overdo it here. To keep the oil from *attracting* sawdust, a

few drops are all that's needed.

One place you'll need to oil is the pivot point for the spring-loaded arm, see detail 'b.' Also, the "knuckle" that lets you tilt the head of the saw to the side may need attention. Finally, add a few drops of oil to the point where the turntable pivots on the base of the saw, see detail 'c.'

Even with the oil, the movement may still be quite stiff. Or perhaps it's just the opposite, and there's so much slop that it will be hard to adjust the saw accurately. Either way, it's an easy fix. Just tighten (or loosen) the nuts at each pivot point to eliminate the "play" without restricting the movement, see details 'b' and 'c.'

BLADE GUARD. One last thing to check is the blade guard. If there's a hitch when you pull the arm down, the linkage that operates the blade guard may need to be tightened, see detail 'd.' Or the parts that guide the linkage may be worn and need to be replaced. (Parts are available at most repair shops.)

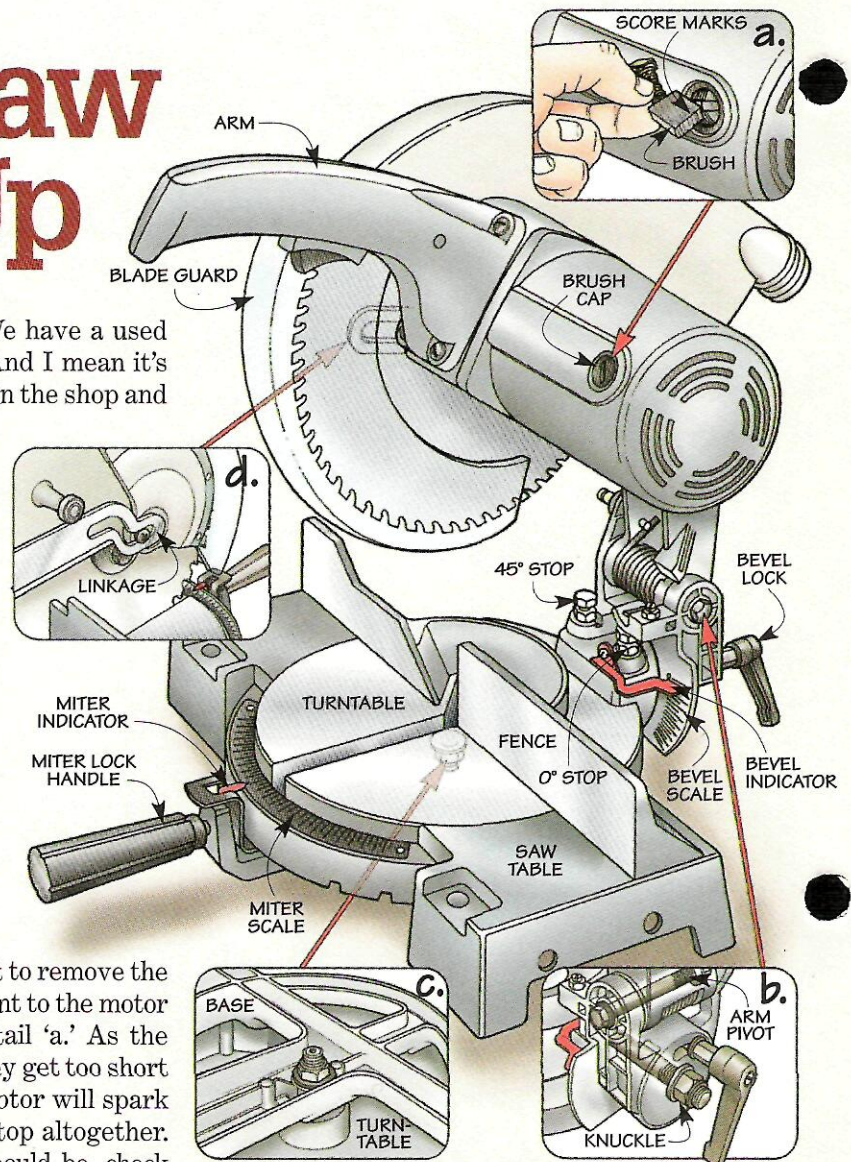

Tune-Up Checklist

- 1 Remove Sawdust.** Clean off any loose sawdust and caked-on pitch and resin — especially around moving parts.
- 2 Inspect Brushes.** Check brushes for wear, and replace them if they're shorter than what's recommended in the owner's manual.
- 3 Lubricate Pivot Points.** Oil the main pivot points on the saw to ensure smooth operation and easy adjustment.
- 4 Check Blade Guard.** Tighten the blade guard if necessary and replace any worn parts in the linkage.
- 5 Adjust Miter & Bevel Settings.** Make two simple adjustments to produce accurate miter and bevel cuts. (See page 15.)

Miter Adjustment

Making a miter cut across the *face* of a workpiece seems simple enough. Just pivot the head to the angle you want. Then push the arm down and lower the blade into the workpiece.

But sometimes no matter how careful you are, there's a slight gap when you fit the pieces together. So how do you track down the problem?

The easiest way is to rotate the turntable to the 0° mark and check whether the blade is square to the fence, see photo below. To do this, you'll need to lock the head in the "down" position and place a

square against the body of the blade (not a tooth).

To make an adjustment, you may need to check your owner's manual to find out where it is. Usually, it's just a matter of loosening bolts on the bottom of the saw and moving the turntable until the blade is square to the fence, see drawing 'A.' (Don't forget to retighten the bolts.) But on some saws, you may need to reposition the fence instead.

Either way, it's a good idea to make a test cut as a final check, see margin. Then just align the indicator with the 0° mark on the scale, see drawing 'B.'



Mark one side of a wide scrap piece and make a 90° crosscut.

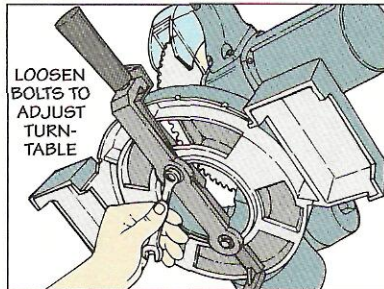

A. Adjust Turntable. After loosening two bolts on the bottom of the saw, adjust the turntable so the blade is square to the fence.

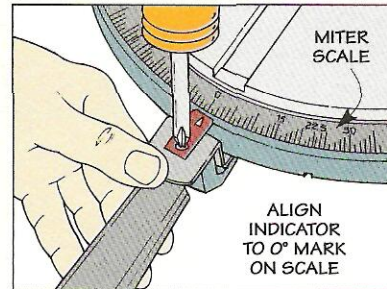

B. Align Indicator. Once you get a perfectly square test cut (see margin), align the indicator with the 0° mark on the miter scale.

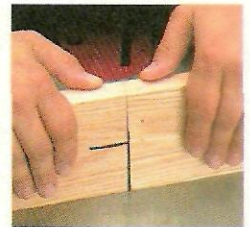

Now flip one of the cutoffs over and butt the pieces end to end to see if there's a gap.

Bevel Adjustment

If you have a compound miter saw (or a sliding compound miter saw), you'll need to make one more adjustment. It determines the accuracy of your cut when you tilt the head of the saw and bevel the *end* of a workpiece.

To make this adjustment, start by unlocking the knob that lets you tilt the arm of the saw. Then just square the saw blade to the table and tighten the knob back down, see photo below.

STOP. To make it easy to return the blade to this setting, most saws have a built-in stop near the

base of the arm, see drawing 'A' below.

TEST CUT. After adjusting this stop, you'll want to make another test cut. Only this time, set the scrap on *edge*. Here again, flip one piece over and butt the ends together to check for a gap. Once the pieces fit tightly together, it's just a matter of setting the indicator on the bevel scale to 0°.

45° STOP. All that's left is to adjust the 45° stop, see drawing 'B.' It lets you tilt the arm quickly and accurately to 45°. As before, you'll want to make a test cut to check the setting, see margin. 

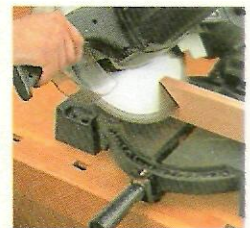

With the head tilted to 45°, cut a tall scrap piece that's standing on edge.

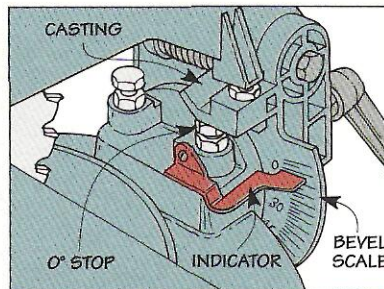
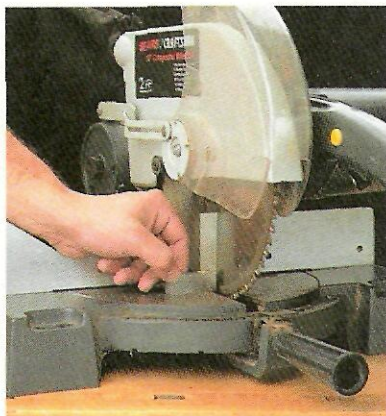

A. Set 0° Stop. After adjusting the 0° stop so it contacts a casting on the arm, align the indicator to the 0° mark on the bevel scale.

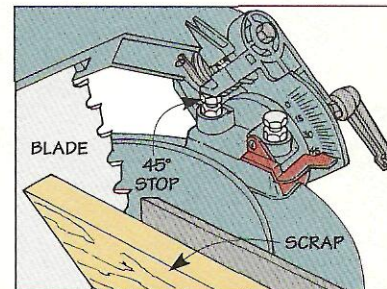

B. Set 45° Stop. To determine where to position the arm when setting the 45° stop, set a scrap that's cut at 45° against the blade.

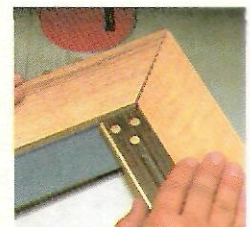

Now form a "corner" with the two cutoffs and check it for square.

Low-Speed Grinding Jig

Like many woodworkers, I've always sent my jointer knives to a professional sharpening shop when they get dull or nicked. Mainly because of this nagging fear that I'd ruin them trying to sharpen the knives on my benchtop grinder.

One reason is the fast speed of the grinder. With a grinding wheel spinning at 3450 rpm's there's always the risk that the thin metal at the edge of the knife will heat up and burn.

To make things even more difficult, the knife has to be held at a perfectly consistent angle while you move it across the grinding wheel. Otherwise, you won't get a nice, even grind all the way across the bevel.

That's fairly easy with a narrow chisel. But it's a real challenge with long jointer knives. Which is why I've always sent them off to be sharpened.

But now that's changed. Recently, Ken (our project developer) showed me this grinding jig that attaches to the table on the drill press.

With a disk-shaped grinding stone chucked in the drill press (see drawing at left), the jig makes it easy to sharpen

Grinding Stone. This grinding stone is mounted to an arbor adapter that's chucked in the drill press. A spacer centers the stone on the adapter.

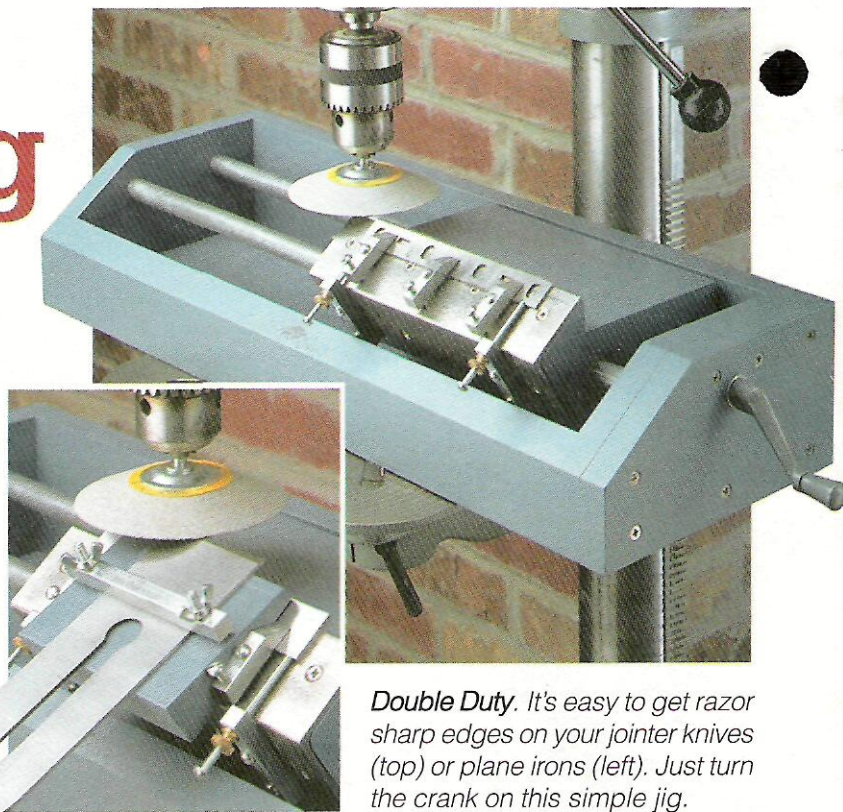
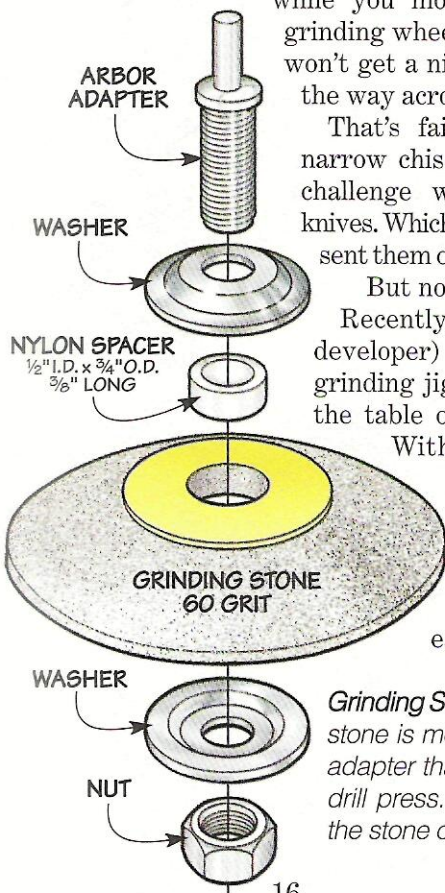

Double Duty. It's easy to get razor sharp edges on your jointer knives (top) or plane irons (left). Just turn the crank on this simple jig.

jointer knives and plane irons. **LOW SPEED.** That's because you can adjust your drill press to run at a *low* speed. (I set mine for 460 rpm's.) The low speed means there's less friction and heat. So you don't have to worry about burning the knife (or plane iron).

CONTROL. But the thing I like best about this grinding jig is it gives me complete control over every step of the sharpening process. To maintain a perfectly

consistent angle, the knife is held in place on a carriage that slides back and forth under the stone.

STOPS. A pair of stops lets you fine tune the position of the knife, see photo A below. And they ensure you get identical results from one knife to the next.

CRANK. To produce a nice, even grind, the process is almost automatic. Just turn a simple window crank to move the carriage slowly back and forth, see photo B.

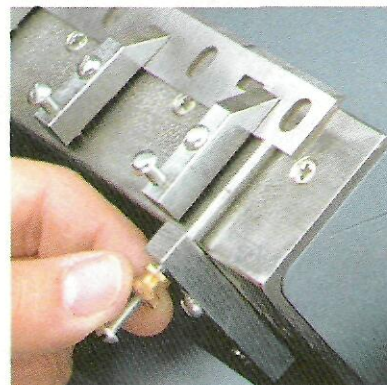

A. Stop. A micro-adjustable stop lets you fine tune the position of the knife. And a set of hold-downs keeps it securely in place.

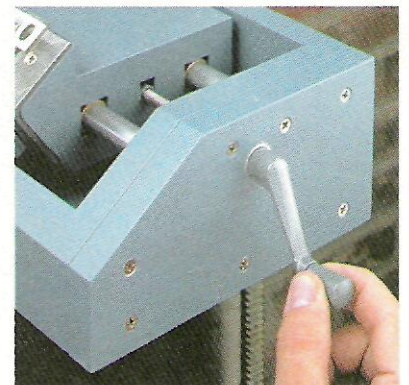

B. Crank. Turning a simple crank moves the carriage that holds the knife (or plane iron) back and forth under the grinding stone.

EXPLODED VIEW
OVERALL DIMENSIONS:
 5" H x 25½" W x 8" D

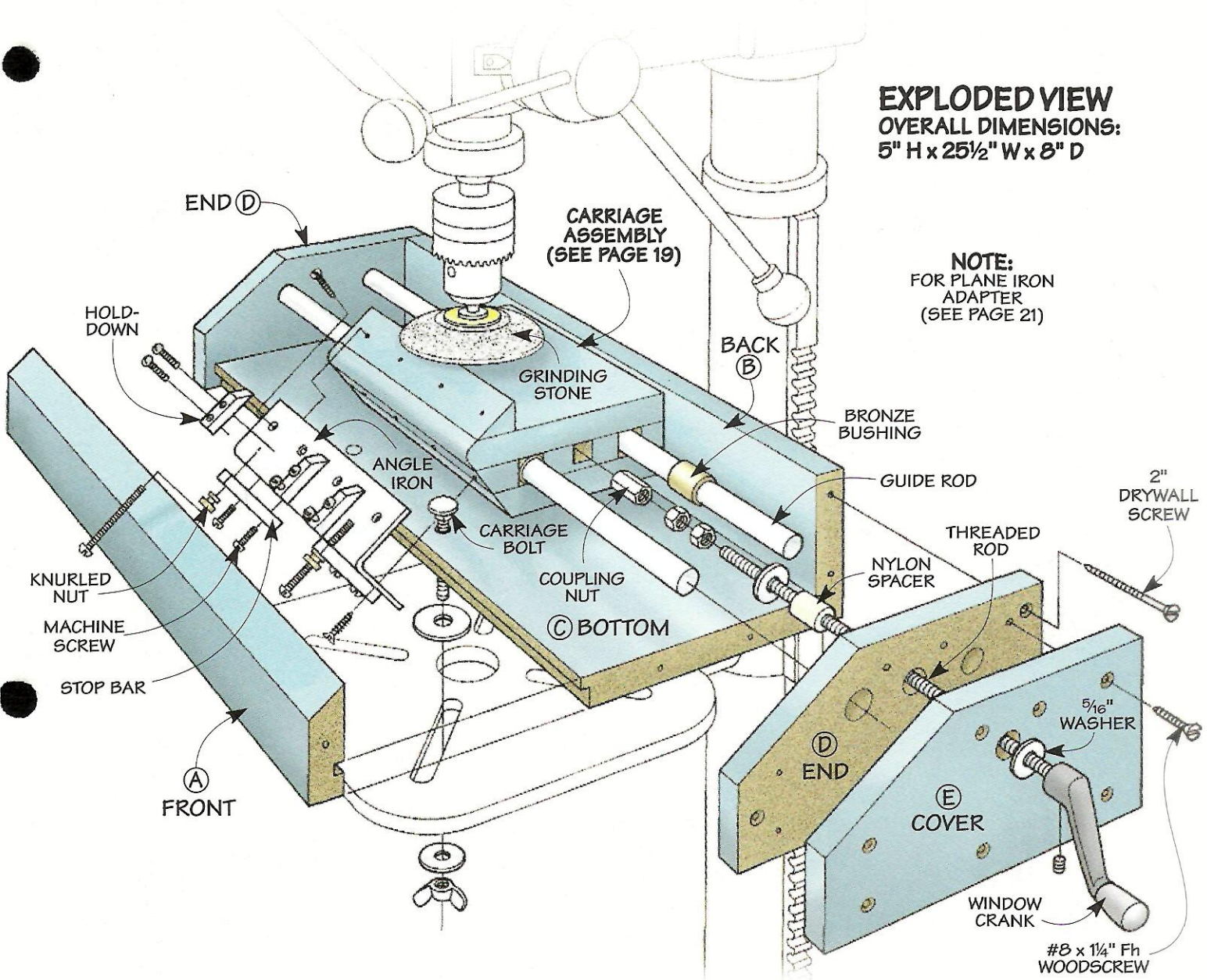

NOTE:
 FOR PLANE IRON
 ADAPTER
 (SEE PAGE 21)

Materials

Base

A Front (1)	2½ x 20 - ¾ MDF
B Back (1)	4 x 20 - ¾ MDF
C Bottom (1)	7 x 20 - ¾ MDF
D Ends (2)	4 x 8 - ¾ MDF
E Cover (1)	4 x 8 - ¾ MDF

Carriage

F Middle Piece (1)	2¼ x 8 - ¾ MDF
G Narrow Keeper Strip (1)	¾ x 8 - ¾ MDF
H Top/Bottom (2)	6¼ x 8 - ¾ MDF
I Wide Keeper Strip (1)	1¾ x 8 - ¾ MDF
J Support (1)	1½ x 8 - ¾ MDF
K Wedge (1)	1 x 3 - 4/8
L Guide (1)	5/16 x 3½ (Rgh.) - 1/8 Hdbd

Hardware

- (1) Norton Grinding Stone - 60 Grit No. 662435-30067
- (1) ½" Arbor Adapter Vermont American No. 17108 (w/nut and washers)
- (1) ½" I.D. x ¾" O.D. x ¾" Nylon Spacer
- (10) 2" Drywall Screws
- (12) #8 x ¾" Fh Woodscrews
- (7) #8 x 1¼" Fh Woodscrews
- (2) 5/8" x 21¼" Steel Rod
- (4) 5/8" I.D. x ¾" O.D. Bronze Bushing
- (1) 5/16-18 x 7/8" Coupling Nut
- (1) 5/16-18 x 15" Threaded Rod
- (1) 3/8" I.D. x ½" O.D. x 1" Nylon Spacer
- (2) 5/16-18 Hex Nut
- (2) 5/16" Steel Washer
- (1) 5/16" I.D. Window Crank
- (1) 2" x 2" - 8" Angle Iron (1/8" Thick)
- (2) 3/8" x 3/8" - 12" Metal Bar Stock
- (4) 8-32 x ½" Machine Screws
- (6) 8-32 x ¾" Machine Screws
- (2) 8-32 x 2½" Machine Screws
- (2) 8-32 Brass Knurled Nut
- (1) 1/8" x 1" - 6" Flat Steel Stock
- (2) 3/16" x 1½" Carriage Bolts
- (2) 3/16" Wing Nuts
- (3) 3/16" x ½" Fh Woodscrews

For a complete hardware kit to build the Low-Speed Grinding Jig (Kit No. 6831-200), call ShopNotes Project Supplies at 800-347-5105 to check availability and pricing.

Base

I began by making the base. It's just an open box that supports a carriage as it slides back and forth on two metal rods, see drawing.

The base starts out as a short *front* (A) piece, a tall *back* (B) piece, and a *bottom* (C) that are held together with tongue and groove joints, see Fig. 1. But before gluing these pieces together, I beveled the top edge of the front to provide clearance for a stop system that's added later.

ENDS & COVER. When the glue dries, the next step is to add two *ends* (D) and a *cover* (E), see Fig. 2. Although these pieces are identical in size and shape, they serve different purposes.

Besides enclosing the sides of the box, each end has two holes to support the metal rods. To keep the carriage from binding on the rods, it's important for the holes to align. So I carpet-taped

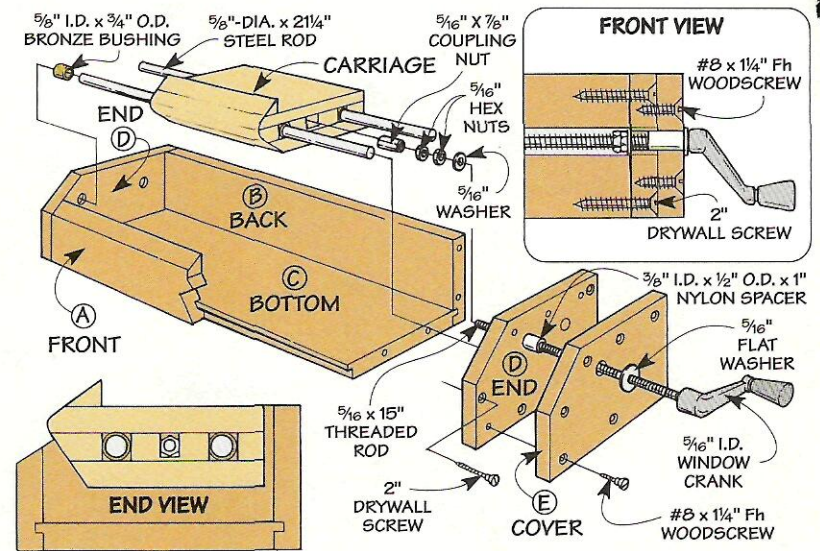

them together to drill the holes. These holes go *through* the end piece on the right, see Fig. 3a. But they're *stopped* in the one on the left. This way the guide rods will be trapped in the end pieces when the cover is

attached later. You'll also need to drill a hole in the *right* end and the cover for a threaded rod that operates the carriage, see Figs. 4 and 4a. **ASSEMBLY.** Now just drill countersunk shank holes in each end

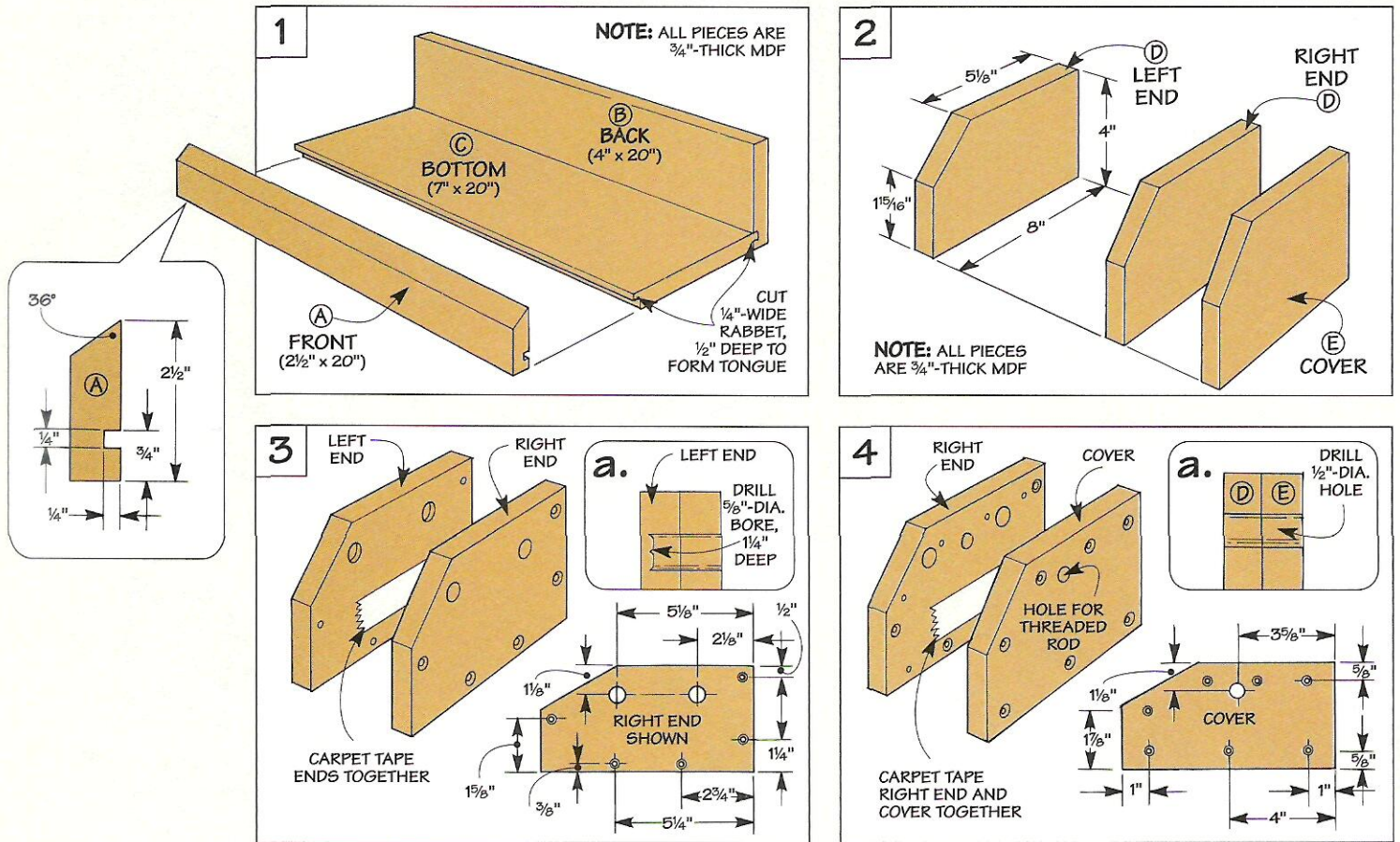

and the cover, see Figs. 3 and 4. To keep the screws from hitting each other, the holes for the screws in the cover are offset from the ones in the ends. After screwing the ends in place, the cover is set aside until later.

CARRIAGE

The sliding carriage is built up like a thick layer cake from pieces of 3/4" MDF. To create "channels" that allow the carriage to slide back and forth, the layer directly above the bottom is made up of three separate pieces, see Fig. 5.

Each channel houses a pair of bushings that the guide rods pass through. To keep the carriage from binding, the important thing is to get the bushings to align with the holes in the end pieces.

To do this, temporarily install the bushings and guide rods, see Fig. 6. Then cut a *middle piece* (F) to width until it just fits between the bushings — not too tight, not too loose.

The next step is to add a coupling nut to transfer the spinning motion of the threaded rod to the carriage, see Fig. 5. It's epoxied in a groove that's centered in the middle piece, see Fig. 6a.

GLUE-UP. Now it's just a matter of gluing up the carriage. Start by gluing a *narrow keeper strip* (G) to the *bottom* (H), see Fig. 5. Then, using the bushings

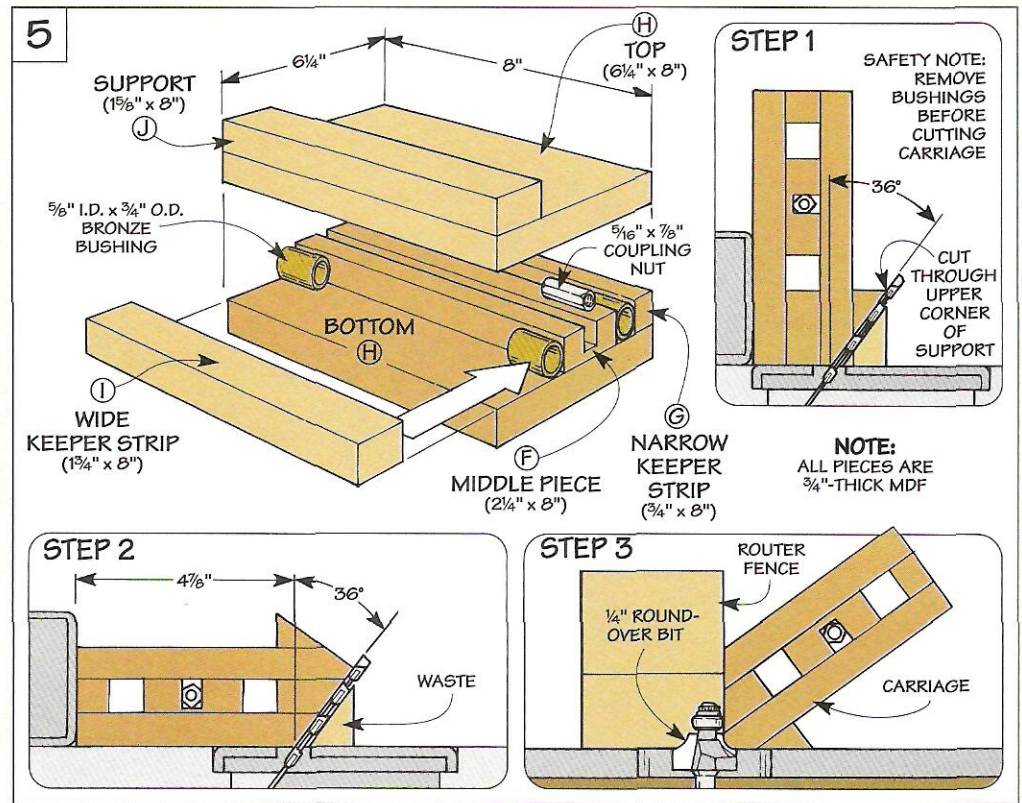

as spacers, glue the middle piece (F) and *wide keeper strip* (I) in place. Finally, add the *top* (H) and a *support* (J) for a piece of angle iron that's added later.

NOSE. When the glue dries, an angled "nose" is cut on the front edge of the carriage to hold the jointer knives at the correct angle.

This involves making two angled cuts. First, tilt the blade on your table saw so the resulting cut will match the

angle of the bevel on your jointer knives, see Step 1. (In my case this was 36°.) The second cut forms a 90° corner that holds the angle iron, see Step 2. Routing a roundover on the edge allows the angle iron to fit tight against the carriage, see Step 3.

BUSHINGS. All that's left is to install the bushings. They're held in place with screws that barely poke into the bushings, see Figs. 7 and 7a.

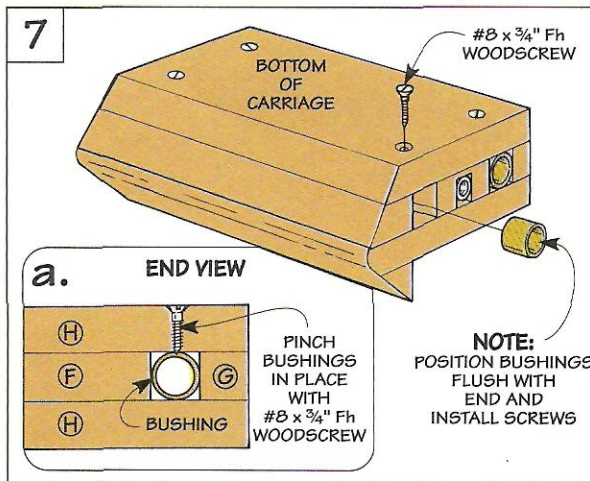
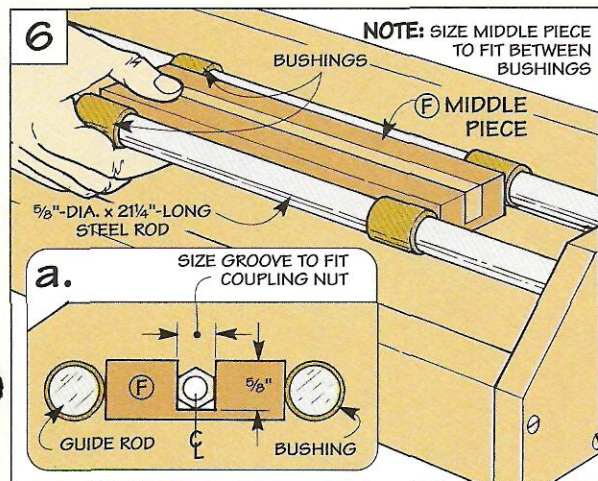

Stops & Hold-Downs

The heart of this grinding jig is a pair of micro-adjustable *stops* that let you position the jointer knives and a set of three *hold-downs* that lock them in place, see drawing at right.

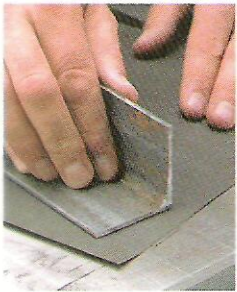

All it takes to sand the angle iron flat is a sheet of silicon carbide paper and a flat surface like the cast iron top of a table saw.

ANGLE IRON. The stops and hold-downs are attached to an ordinary piece of angle iron. In use, the jointer knife is pressed tight against this angle iron. So to avoid leaving high and low spots, you'll need to sand the angle iron flat, see margin.

Once the angle iron is nice and flat, drill countersunk shank holes for screws that will be used to attach it to the carriage.

STOPS. The next step is to add the two stops. Each stop is just a machine screw that threads into a short metal stop bar, see detail 'a.' The end of the screw rests

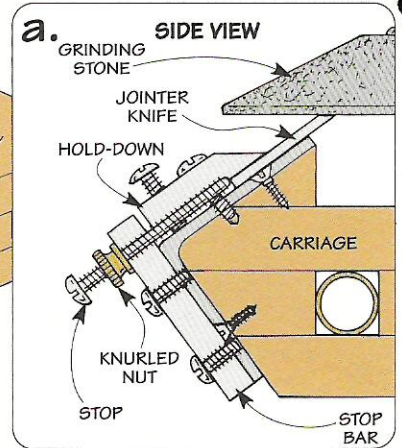
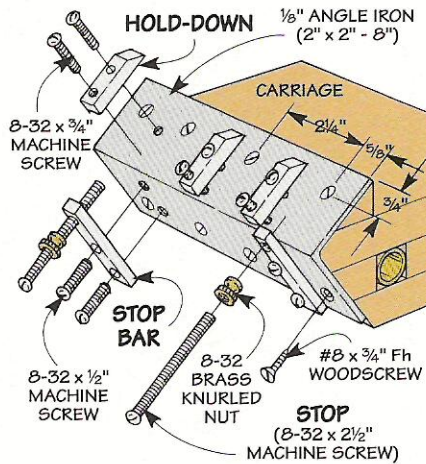

against the back edge of the knife. So by adjusting the screw in and out, you can fine tune the height of the knife. A knurled nut locks the stop in place.

To make each stop bar, start by drilling three holes in a piece of metal bar stock, see Fig. 8.

The hole at the end is drilled and tapped for the machine screw. The other two are drilled only (no threads) so you can attach the stop bar to the angle iron.

When positioning the bar, you want the machine screw to be just barely above the angle iron. This way, you can turn it without binding. Yet it's close enough to the angle iron so it will contact the back edge of the knife.

The easiest way I found to do this is to thread the machine screw into the stop bar and use a playing card as a shim, see Fig. 9. Then, after marking the location of the bottom two holes (Fig. 9a), drill and tap holes in

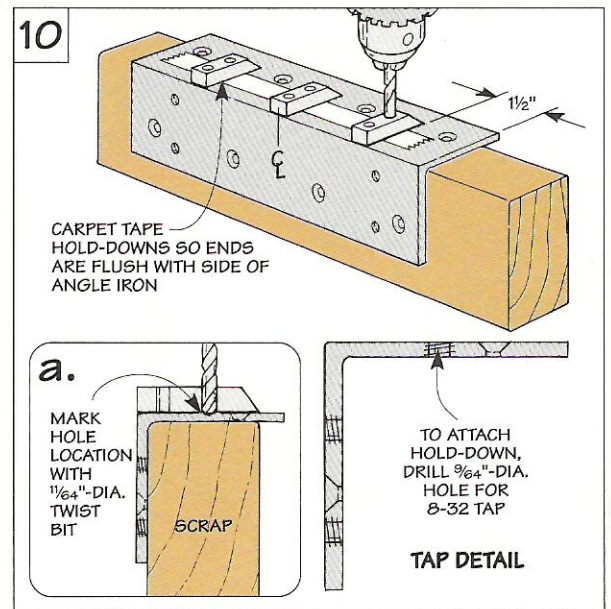
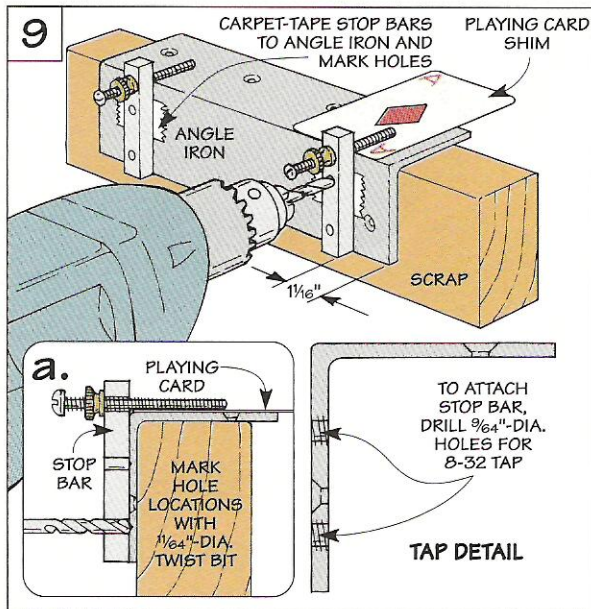
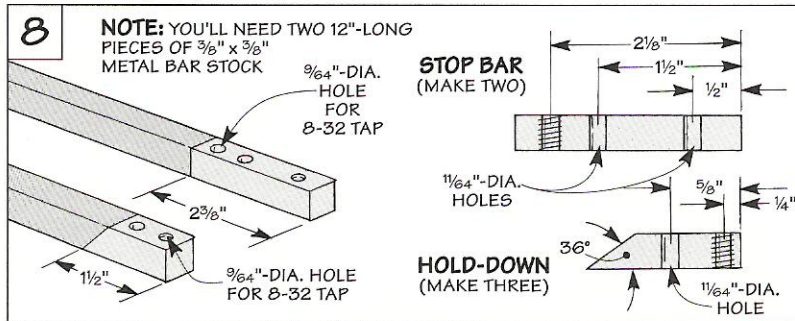

the angle iron, see Fig. 9.

HOLD-DOWNS. With the stops complete, you can add the three hold-downs. These are short pieces of metal bar stock with a beveled end that provides clearance as the carriage passes under the stone, see Figs. 8 and 10.

Each hold-down has two machine screws that work together to apply clamping pressure. The screw near the beveled end fastens the hold-down to the angle iron. And the other screw raises the back end of the hold-down slightly as it's tightened. This presses the tip of the

hold-down against the knife. To make this work, the hole near the beveled end is drilled oversize and left unthreaded, see Fig. 8. (Here again, I started with a long piece of bar stock.) And the other hole is drilled and tapped.

After cutting each hold-down to length, it's just a matter of marking the locations of the holes in the angle iron that will be used to attach them, see Figs. 10 and 10a. Then just drill and

tap the holes as before.

PLANE IRON

The grinding jig can also be used to sharpen a plane iron. But there's a slight "catch."

BEVEL ANGLE. The angle of the bevel on a plane iron is usually about 25°. But since the angle on the carriage is 36°, this means you'd be grinding the bevel at the wrong angle.

WEDGE. The solution is a wood wedge that compensates for the difference in the two angles. (I cut an 11° wedge.) It's attached to the carriage with a metal strap that slips under the hold-downs, see detail 'b' above.

BLANK. To cut the wedge safely, it's best to start with an oversized blank, see margin. Then make a series of three cuts on the table saw before cutting the wedge (K) to final length, see Figs. 11.

PRESSURE BAR. The next step is to add a metal bar that presses the plane iron tight against the wedge. This requires drilling holes

for two carriage bolts that pass through the wedge and pressure bar, see Fig. 11a. Tightening a wing nut on the end of each bolt locks the plane iron in place.

GUIDE. To help square up the plane iron, I added a simple guide (L). It's a narrow strip of 1/8" hardboard that's glued into a kerf cut in the wedge.

ASSEMBLY

At this point, you're ready to assemble the grinding jig.

The first step is to attach the angle iron to the carriage with screws and epoxy. Then install the stops and hold-downs.

CARRIAGE. Now you can add the carriage. Start by slipping the guide rods into the end of the base. Then slide the carriage onto the ends of the guide rods. After pushing the rods into the holes in the opposite end of the base, just screw the cover in place.

All that's left is to install the hardware that makes the carriage slide back and forth. To do this, attach the crank to the threaded rod, refer to drawing on page 18. Then pass it through a nylon bushing in the cover. Finally, slip on a washer and two "jam" nuts, and thread the rod into the coupling nut in the carriage.

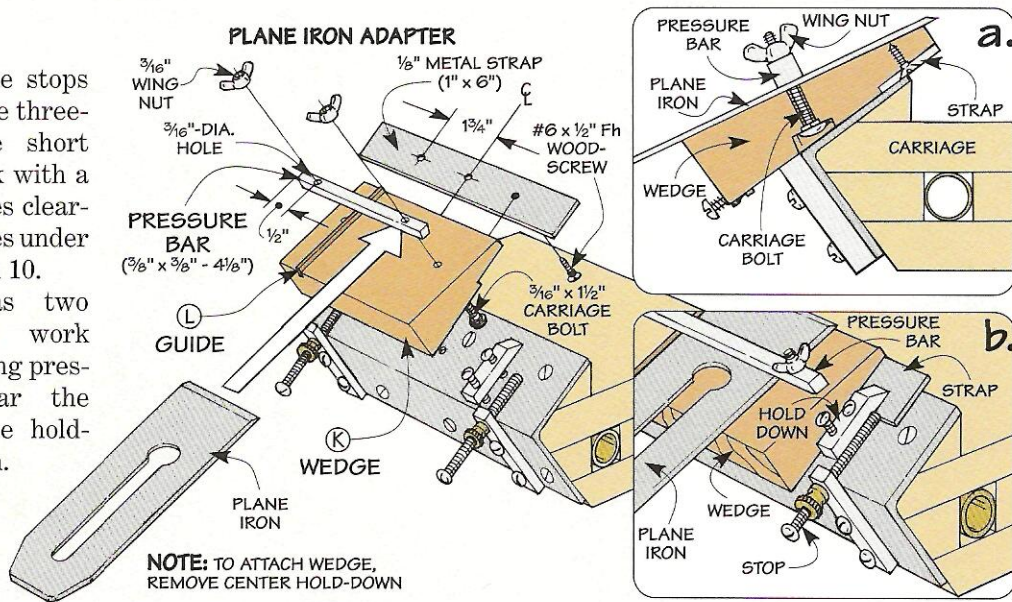

NOTE: TO ATTACH WEDGE, REMOVE CENTER HOLD-DOWN

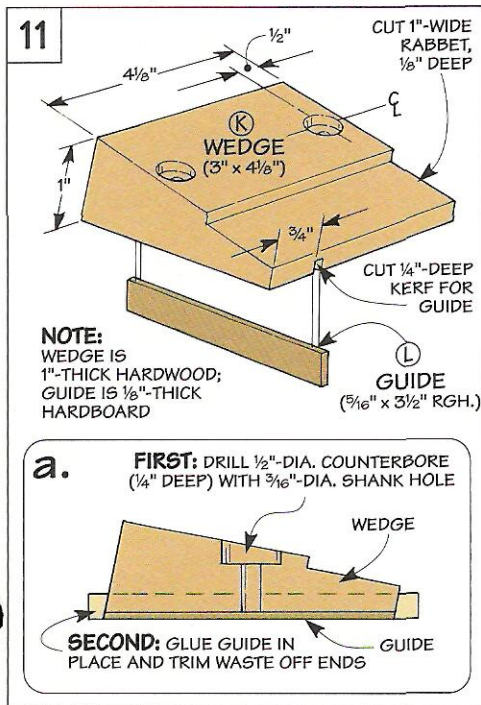

NOTE: WEDGE IS 1\"/>

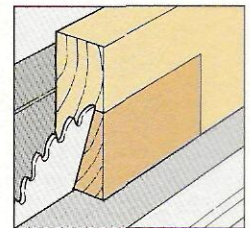
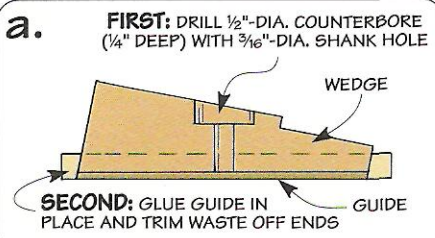

To cut the wedge, start by ripping the blank at an angle.

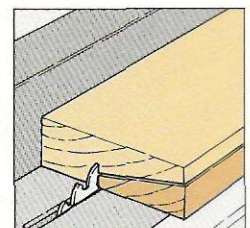

Cutting the wedge to width "frees" it from the blank.

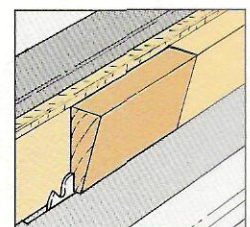

Finally, cut a shallow rabbet to accept the metal strap.

Setup

All it takes is a few minutes to set up the grinding jig.

MOUNT JIG. The jig is held in place with carriage bolts. To locate the holes for these bolts, you'll need to position the jig on the drill press table. This varies depending on whether you have 6" or 8" jointer knives.

For 6" knives, the jig is centered from side to side, see Step 1. But for 8" knives, the jig is offset 1" to the right. This way, you won't hit the grinding stone when installing (or removing) a knife.

You'll also need to position the jig from front to back. What works best here is to leave a 1/2" gap between the support (J) and the nut that holds the grinding

stone on the arbor adapter, see detail 'a' in Step 1.

ATTACH JIG. Now you're ready to attach the jig. What's unusual here is that the jig doesn't sit flat on the table. Instead, I raised the end with the crank just a bit, see Step 2. This way, only the right side of the grinding stone will contact the knife. This means there's less friction, so heat won't build up in the knife.

FLATTEN STONE. With the jig in place, the next step is to flatten the grinding stone, see Step 3. This is just a matter of holding a dressing stick (see margin) on top of the carriage. Then, with the drill press running, lower the stone until it just

touches the dressing stick.

INSTALL KNIFE. At this point, you can slip one of the knives under the hold-downs until it bottoms out on the stops. The idea here is to get the bevel on the knife to contact the stone equally at both ends. To do this, I adjusted the stops until a playing card had the same amount of resistance at each end, see Step 4.

STONE HEIGHT. All that's left is to adjust the height of the grinding stone. The goal is to set the stone to make a very light cut. The easiest way to do this is by sound. This is just a matter of lowering the stone until it makes a light rasping sound and locking it in place, see Step 5.



A silicon carbide dressing stick makes quick work of flattening a grinding stone.

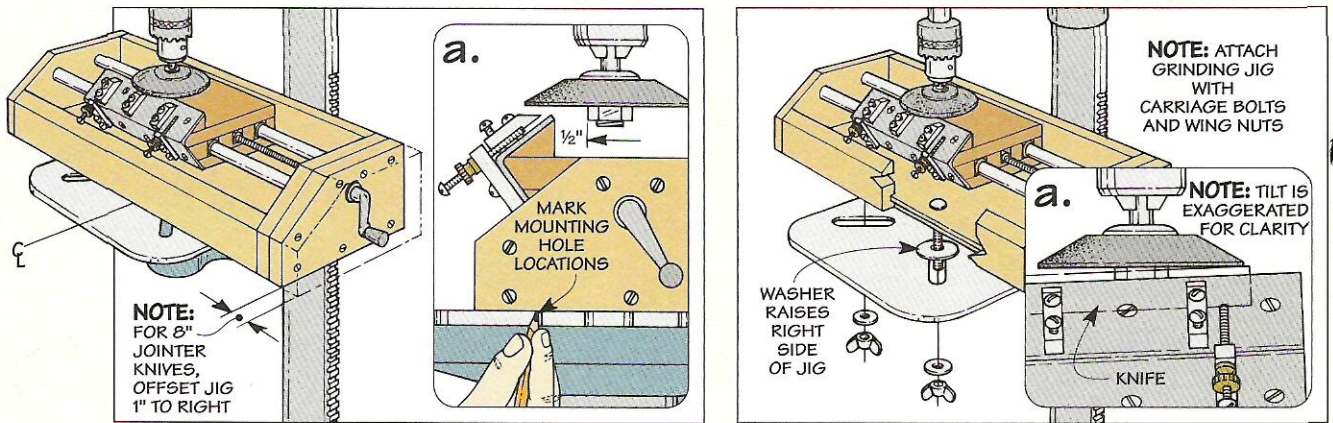

Step 1. Start by positioning the jig from side to side (for either 6" or 8" jointer knives). Then, after locating it front to back, mark and drill the mounting holes.

Step 2. To raise the end of the jig with the crank, slip washers over the two nearest carriage bolts so they fit between the base and the drill press table.

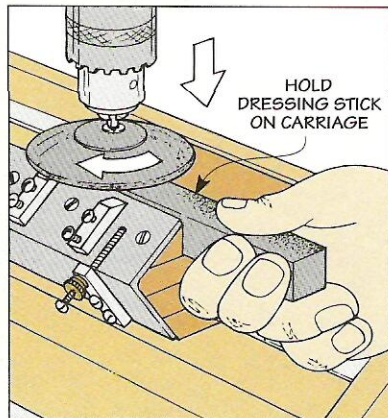

Step 3. Lower the spinning grinding stone onto a dressing stick to "true up" the stone.

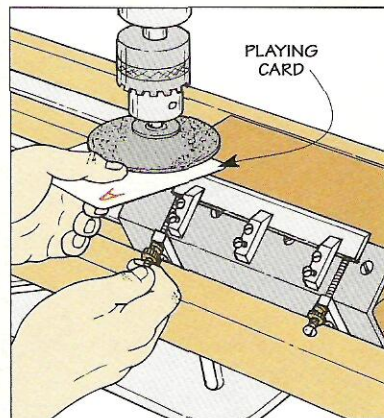

Step 4. A playing card works like a feeler gauge as you adjust the stops to position the knife.

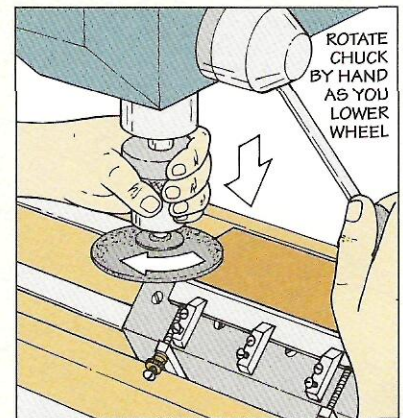

Step 5. Finally, lower the grinding stone to make a very light cut and lock the quill in place.

Using the Jig

Using the grinding jig is a lot like fishing on a lazy afternoon. You'll get the best results using a slow, deliberate approach.

SPEED. Start by setting the drill press to the *lowest* possible speed. Then, with the carriage all the way to the right, flip the drill press on and turn the crank slowly.

The idea is to keep turning the crank until the carriage travels far enough that you can't hear the grinding stone making contact with the knife. Then turn the crank in the opposite direction to return the carriage to the starting point, see Step 1.

CHECK BEVEL. With the initial pass complete, you'll want to take a look at the bevel. Ideally,

you'll see a nice, even grind. But in practice, the grinding marks may run at a slight angle across the bevel. That's probably because the knife is higher at one end.

ADJUST STOPS. To correct this, use the stops to raise the knife at the *low* end. Then make another pass (down and back). You may have to repeat this process a few times. But the nice thing about it is the stops will be automatically set for the next time you need to sharpen the knives.

FINAL GRINDING. Once the stops are adjusted, you can complete the grinding. To keep the knives balanced, you'll need to remove the same amount of material from each one. This

means making the same number of passes for each knife.

The best way I found to get consistent results is to grind each knife at one height setting. Then, if the knives are badly nicked (or the grind marks don't cover the entire surface of the bevel), lower the stone just a hair and grind all the knives at that setting, see Step 2.

HONE BEVEL. Now all that's left is to hone the bevel. (I use a diamond hone, see margin.) This removes the burr that forms as you grind, see Steps 3 and 4. And it creates a small secondary bevel that's more polished (sharper) than the rough bevel left behind by the grinding stone. 

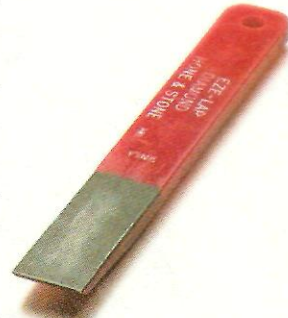

Use a fine diamond hone to remove the burr and add a secondary bevel to the edge of the knife.

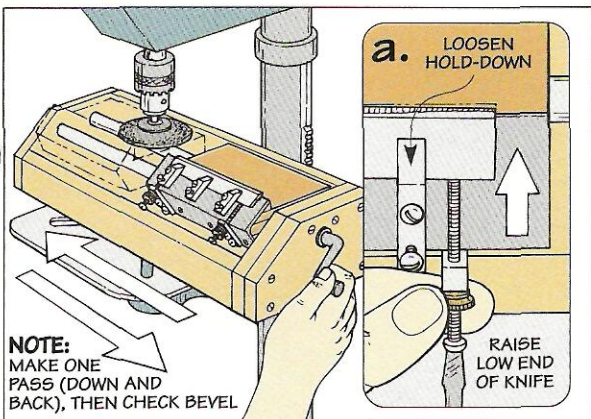

Step 1. After making an initial pass (down and back), inspect the grinding marks on the bevel. If they run at an angle, raise the low end of the knife.

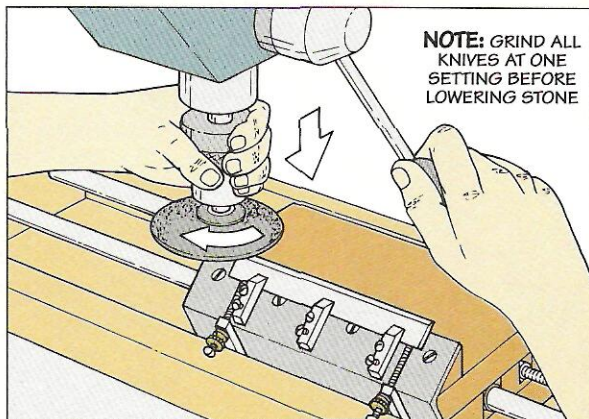

Step 2. After grinding all the knives at one height setting, lower the stone slightly. Repeat the process until the bevel is flat and any nicks are removed.

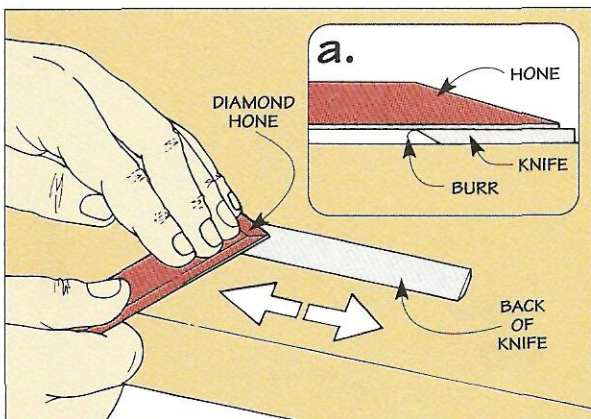

Step 3. To remove the burr that forms, "bend" it back and forth several times by alternately honing the back, then the bevel of the knife, see Step 4.

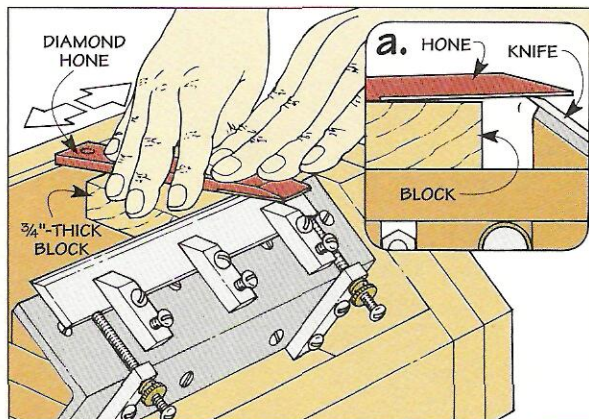

Step 4. After reinstalling the knife, a secondary bevel is formed by honing the bevel. Supporting the hone on a block ensures a consistent angle.

Compound Miter Saws

If there's a woodworking equivalent to kicking tires on a car, it's checking out a power miter saw. And if you spend as much time as I do in the tool department at the local home center, you probably know the routine by heart.

Grasp the handle and push down on the spring-loaded arm. Now pivot the head of the saw — first to the left, then to the right. And if it's a *compound* miter saw, don't forget to tilt the head of the saw to the side.

Since these saws have been around for a number of years,

this basic operation is pretty familiar. But what's different is the *size* of the saws — they're getting bigger all the time.

12" COMPOUND MITER SAWS. A good example of this is the new 12" compound miter saws. While the large blades on these saws may look like overkill at first, the extra cutting capacity this provides makes a lot of sense.

For example, you can crosscut a 2x8 or cut a miter on the end of a 2x6 — something you can't do with the smaller 10" saws. And if you're working on a deck or remodeling project, those are just the type of cuts you might need to make.

The large cutting capacity also comes in handy when you're cutting a bevel on a *wide* workpiece (like a wide piece of floor trim) or a compound angle on a piece of crown molding. With the head of the saw tilted to the side, you can lay the workpiece *flat* on the table and cut all the way across.

HOME SHOP. But these saws aren't just "construction" tools. They're also a perfect crosscutting tool for a home shop. You can use them to cut lumber to rough length. Or cut precision miters in the long pieces of a frame.

TEST. But which one of these 12" compound miter saws is best? To find out, we bought the only four saws that are currently available and rounded up our team of three woodworkers to put them to the test.

Ken is a professional cabinet-maker. *Steve* is an advanced woodworker. And *Cary* has been working wood for about a year now.

Q: *Aren't these big saws a chore to lug around?*

Steve: Not really. With aluminum bases, fences, and blade guards, they're pretty lightweight. Even so, they are a bit awkward to carry around. So it's handy to have built-in handles at the top of the arm. (See photos below.)

Ken: What's more important to me is the handle that I use to lower the arm of the saw when I'm making a cut. Since I make hundreds of cuts a day, it has to be comfortable.

That's why I liked the horizontal handles on the DeWalt and Skil. (See photos on bottom of page 25.) With these, my hand and wrist are in a more relaxed position than when I use the vertical handles on the Sears and Delta.

Delta 36-230
800-438-2486



DeWalt DW705
800-433-9258



Portability. A convenient handle and a recess in the base make it easy to carry the DeWalt (left), Skil, and Sears. But the Delta (right) doesn't have either, so it's harder to move around.

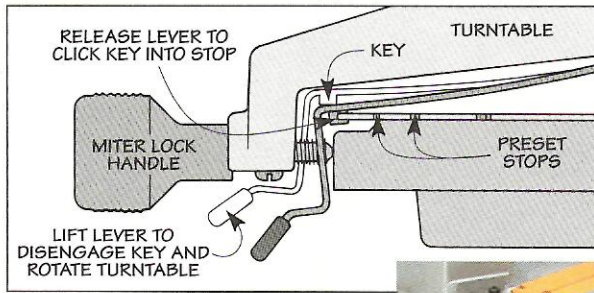
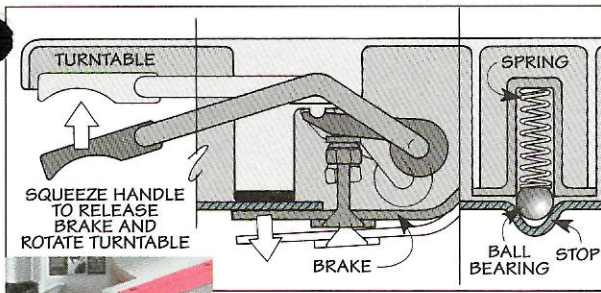

Miter Locks. To quickly rotate the turntable on the Delta (left), just squeeze the handle. Then let it go to lock the turntable in place. With all the other saws, you need to turn a knob to lock (or unlock) the turntable which takes a little more time.

Cary: The safety switch on top of the Sears compounds the problem. To reach the switch with my thumb, I have to cock my wrist at a weird angle.

Steve: Even so, it's better than the safety switch on the Skil. Since it's located on the left corner of the handle, you can forget about turning on the saw if you're left-handed (or if you need to hold a workpiece with your right hand).

Q: How about the basic pivoting operation of the head when you're cutting a miter?

Ken: The bottom line is the head has to pivot smoothly. And when I rotate the turntable to the correct angle, it has to lock in with dead-on accuracy. That's just what I was able to do with the DeWalt, Delta, and Sears. But the Skil "creeps" about a half of a degree when I tighten the miter lock.

Cary: One thing I noticed is the miter locks on the saws are different. With the Delta, I just

squeeze a handle to release the lock, rotate the turntable, and let go when I get to the angle I want. (See photos above.)

The other saws have a knob that you turn to lock (or unlock). They work fine, but fiddling with the knob takes a bit more time.

Steve: Regardless of the lock, all the saws have preset stops so you can automatically "find" the common miter angles.

On the DeWalt, Skil, and Sears, this is a spring steel key that clicks into a notch — I know when I'm there. But the Delta feels "soft." It has a spring-loaded ball bearing that falls into a pocket in the base. But unless I jiggle the handle back and forth to lock it in, I'm off by as much as a degree.

Ken: I wouldn't worry about the preset stops too much. How often are they going to be perfectly accurate for the project you're working on anyway? Usually, you'll need to cut an angle that's just slightly different than

the preset angle. But the key (or ball bearing) will pop into place when you get close. So it's hard to set a fraction of an angle.

That's what's nice about the Skil. It has a small lockout clip that lets me "short circuit" the preset stops.



Sears 23512
800-290-1245



Skil HD3812
877-754-5999

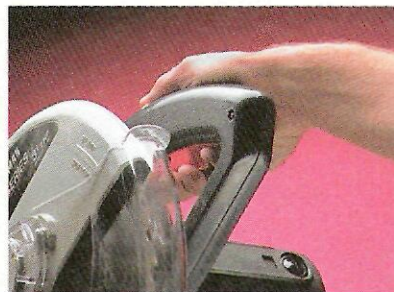
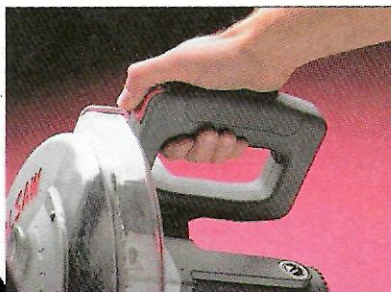

Handles. A horizontal handle (left) is more comfortable to use than a vertical handle (right). But regardless of the style of handle, the safety switch on the Skil (left) and Sears (right) are awkward to use.

Performance



Crosscutting. To get a feel for the basic crosscutting operation and controls of each saw, we cut stacks of “two-by” material.



Miters. We also wanted to see how easily and accurately we could use these saws to cut miters for door and window trim.



Bevels. Cutting bevels in 2”-thick oak gave us an idea of the power of the saw and whether the blade deflected in a heavy cut.



Crown Molding. Finally, we cut compound angles on pieces of crown molding and fit them around the top of a simple cabinet.

Q: When it comes right down to it, these compound miter saws have one basic job to do — crosscut stock to length. How did you go about testing their performance?

Ken: We wanted to see how these saws handled a variety of crosscutting jobs. Everything from getting a square cut on the end of a workpiece to cutting miters, bevels, and compound miters. (See photos at left.)

Besides checking the accuracy of the saws, that also gave us a good feel for their overall operation. Rotating the table to cut miters. Tilting the head to make bevel cuts. Lowering the spring-loaded arm.

Steve: The smoothness of the arm is where I noticed a big difference. It was easy to lower the arm to make a cut on the Delta, Sears, and DeWalt. But the Skil had a little “hitch” in it.

The reason is the blade guard kept hanging up on some rough edges on the linkage that retracts the guard.

After I filed the rough edges, the movement was a little better. But it still didn’t have the smooth action of the other saws.

Q: Did that have any affect on the quality of the cut?

Steve: Besides distracting me every time I felt the hitch, the only thing I noticed was some chipout on the bottom of the workpiece. But that was happening on all the saws.

Ken: That’s not surprising considering that they all come with blades that have either 32 or 40 teeth. The first thing I’d do is buy a good crosscut blade — one with at least 60 to 80 teeth.

Cary: I did notice one thing. The blades on the Sears, Skil, and DeWalt sliced through wood like a hot knife through butter.

That’s because they all have

thin-kerf blades. The blade on the Delta cuts a standard thickness kerf and tends to bog down a little. Especially when I make bevel cuts in thick material.

Q: What about changing blades on these saws?

Steve: Even though I probably wouldn’t change blades all that often on a miter saw, it’s easier on the Sears and Delta.

With these saws, the blade guard stays up. That gives me two free hands — one to hold the spindle lock and the other to unscrew the arbor nut or bolt.

The guards on the Skil and DeWalt don’t stay up by themselves. So I need a “third hand” to change blades.

Q: Besides the blade guards, what other safety features do these saws have?

Steve: They all have hold-downs to clamp a workpiece while you’re making a cut. These hold-downs are standard with the Delta and Skil. But we had to buy the hold-downs for both the DeWalt and Sears.

I especially like the one on the Sears because I can apply pressure in *two* directions. (See photos at top of page 27.) Straight down for stock that’s flat on the saw table. Or if I have a tall workpiece, I can clamp it against the fence.

Even though the hold-down on the DeWalt only clamps in one direction, I like how quickly I can put it on the saw or take it off. I just slip it into a mounting hole on either side of the table.

Another thing about the hold-down on the DeWalt is it has a quick-release lever. All I have to do is flip the lever back and slide the threaded rod in or out until the clamp head is against the workpiece. Tightening the knob clamps the work securely in place.

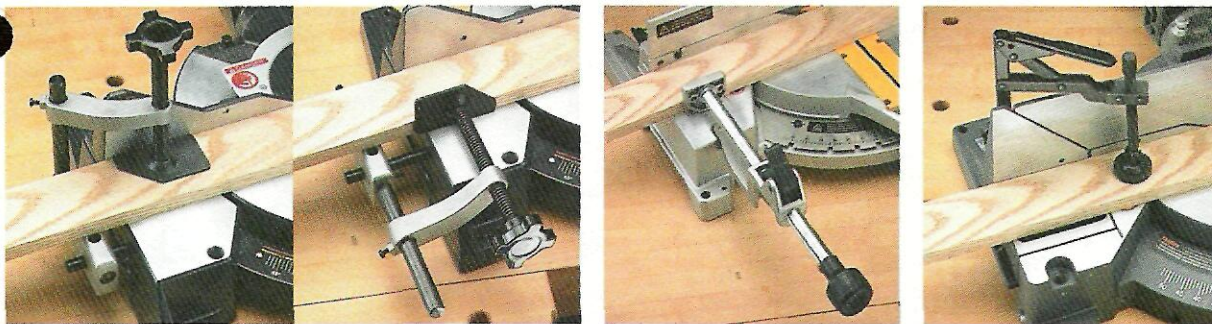

Hold-Downs. The hold-down on the Sears can be used to clamp work down against the saw table (left) or against the fence (left center). So it has a wider range of uses than the DeWalt (right center) that holds work against the fence only, or the Skil (right) that only applies pressure downward.

Cary: The hold-downs on the Skil and Delta don't apply as much pressure. And it's a nuisance backing the threaded rod off far enough so you can put a workpiece underneath.

Ken: I guess I don't use hold-downs all that much anyway. They usually don't hold the workpiece securely enough. And they're just too slow to use.

What's more important to me is how well the fence supports

tall workpieces — like when I cut crown molding.

For accurate cuts, the fence needs to support the workpiece on *both* sides of the saw blade. That way, the workpiece won't "give" as the cut is made.

The fences on the Sears and Delta are too low to provide that support. Both the DeWalt and Skil have high fences that support the workpiece on each side.

But tall fences get in the way

when I tilt the head for a bevel cut. So I need to be able to move the fence out of the way quickly.

That's easy on the DeWalt. All I have to do is loosen a couple knobs and slide it out of the way. (See photos at left.)

On the Skil I have to take out two bolts and completely remove the fence — and that's a hassle.

Steve: One last thing. I noticed that the fence on the DeWalt bowed out just a bit in the middle. At first I thought it hadn't been milled correctly at the factory.

But after looking into it, I found that the problem wasn't the fence. The bolts that hold it to the saw table had been overtightened to the point that it actually "bent" the fence. But when I loosened the bolts, the fence sprung back so it was perfectly flat.

Just to be safe, I'd make sure to check that *any* fence is flat and square to the saw table before buying a saw. 🐼

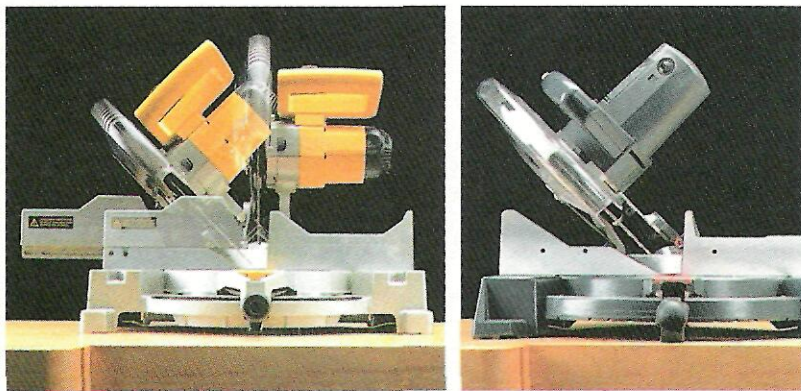

Fences. When you need to tilt the head of the saw to the side to cut a bevel, the tall fence on the DeWalt (left) slides conveniently out of the way. But you have to remove the fence on the Skil (right).

Recommendations

Cary: Picking the best miter saw was tough. But when it comes right down to it, I'd choose the DeWalt for my shop.

All in all, it's an easy saw to use. A comfortable handle and squeeze trigger. A quick-release hold-down. And a miter scale that's easy to read.

Steve: At first, I was leaning toward the Delta. I just wish the turntable clicked into the preset stops with a more positive feel.

So I picked the DeWalt. Besides everything that Cary said, I liked the tall fence. And being able to slide it out of the way for bevel cuts is a real plus.

Ken: I guess that makes three of us — I'd buy the DeWalt too.

Everything about it tells me it's a quality tool. A nicely machined fence and saw table. Its smooth operation when I rotate the turntable or tilt the head of the saw. And the solid feel of the arm when I make a cut.

Shellac

When it comes to finishes, shellac is an "old timer." But it offers solutions for many modern-day finishing problems.

I'd just applied a coat of finish to a cedar chest and set it aside to dry — or so I thought. The next day, it was still tacky. And a week later, it wasn't dry yet. In fact, the finish had separated into little sticky balls.

After checking around a bit, I found that certain types of cedar react with oil-based finishes and prevent them from drying. So I stripped the old finish and started over. But this time I used a different finish — shellac.

The shellac dried almost immediately and gave the chest a nice, warm look. Since it worked so well on the chest, I started using shellac for other projects. And I found several other uses for it as well, see box on page 29.

ADVANTAGES. But no matter how it's used, shellac has several things going for it as a finish. For instance, it provides an excellent

barrier against water vapor (just look at all the turn-of-the-century furniture that's still in excellent shape). And shellac dries fast too. So you can apply several coats in a day without having dust settle in the finish. Finally, since it's not an oil-based finish, it doesn't smell bad or produce toxic fumes.

All these things make shellac an ideal finish for a project like a dresser, a blanket chest, or a set of book shelves. But it's probably the last finish you'd want to use on a kitchen table.

That's because even though it's resistant to water vapor, shellac doesn't protect against liquid water. (Remember the white ring on grandma's coffee table?) And spilling a drink with alcohol will dissolve the finish

right before your eyes.

RESIN. That's because shellac is a natural resin that's dissolved in denatured alcohol. This resin is usually sold as dry flakes that vary in color from dark brown to bleached white, see photos below.

CUT. Regardless of the color, the amount of shellac you mix with alcohol is called a "cut." For instance, a two-pound cut (which is what I use most often) means that two pounds of shellac are dissolved in one gallon of alcohol.

But rather than mix up a whole gallon of finish, I usually mix smaller amounts. A small kitchen scale makes it easy to get the right proportions.

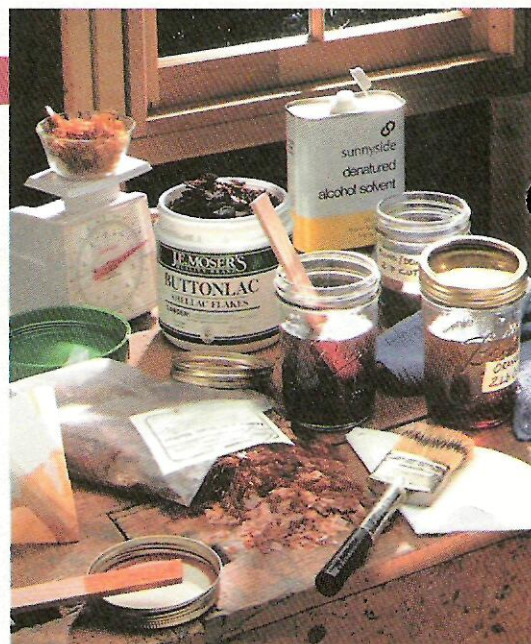

Sources

- Garrett Wade
800-872-2511
- Woodworker's Supply
800-444-7002
- Wood Finishing
Products
216-582-8929



Buttonlac
This unrefined, dark brown shellac is used to restore finishes on antique furniture.

Garnet
Garnet shellac is more refined. Its light brown color produces an old-time look.

Orange
With its warm, amber color, orange shellac is an ideal general purpose finish.

White
Since it's colorless, use white shellac as a sealer or for a transparent finish.

Mixing & Applying Shellac

Mixing up a batch of shellac is like marinating meat for next weekend's barbecue — you have to do it in advance. That's because it takes a couple of days for the alcohol to completely dissolve the shellac.

To start with, you'll need to decide on which cut of shellac to use (one-pound, two-pound, etc.), see photo A. After measuring out the right amounts of shellac and alcohol, just mix them together. Note: Shellac reacts with metal, so I use glass jars.

To keep the flakes from solidifying into a lump at the bottom of the jar, you'll need to stir the mixture several times the first few days. Also, you'll want to keep the jar tightly covered to prevent the alcohol from evaporating.

WAX. If you don't use the shellac right away, you may notice that the bottom of the jar looks cloudy. That's just the natural wax that's in unrefined shellac settling to the bottom.

The problem is this wax reduces the amount of protection shellac will provide against water vapor. So you'll need to "pour off" the shellac into another jar and leave the wax behind. A

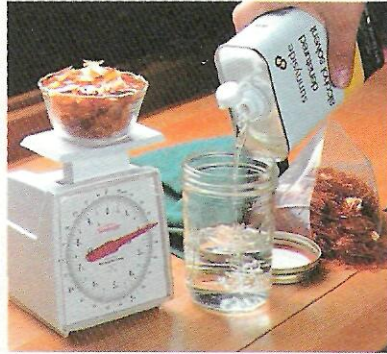

A. Cut. Weigh the flakes of shellac and measure out the alcohol to determine the correct "cut."

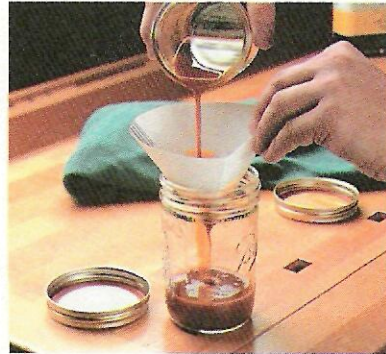

B. Strain. After the shellac is completely dissolved, strain it through an ordinary paint filter.

paint filter will remove any other foreign material, see photo B.

APPLICATION. Now you're ready to apply the finish. Since shellac dries fast, the secret is to brush it on quickly with smooth, even strokes. (A natural bristle brush works best.) If you get a drip or a run, go back over it right away. Otherwise, just let it dry — you can sand it later.

After the first coat dries, the surface may be a bit rough. That's because the alcohol in the shellac raises the grain of the wood. So I knock off the "whiskers" by sanding with 600-grit sandpaper.

Now it's just a matter of applying a couple more coats.

Since the alcohol will "melt" each new coat into the previous one, you don't have to worry about sanding in between. Just sand the final coat *lightly* with 1000-grit silicon-carbide sandpaper to create a smooth finish.

SHELF LIFE. One final note. If there's any shellac left, it's a good idea to mark the date on the jar. That's because liquid shellac has a shelf life of just a few months (dry flakes can be stored for up to ten years).

What happens is the shellac will start to take longer and longer to dry. Eventually, it won't dry at all. A simple test will tell you if it's okay, see margin. 🛠️

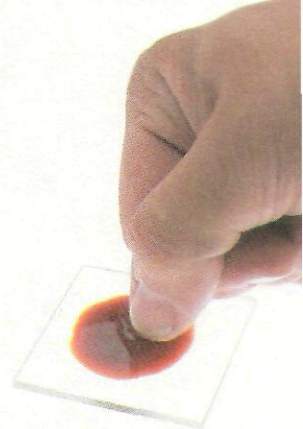

If you can make a dent with your fingernail in a few drops of shellac that have been left overnight, mix up a fresh batch.

Shellac — a General Purpose Finish

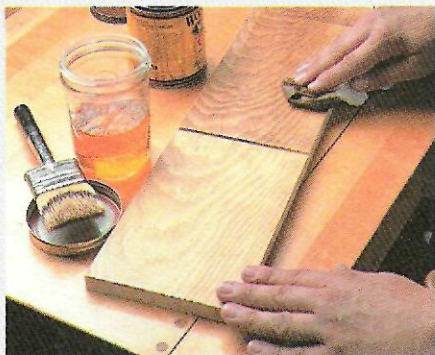

Conditioner. To help prevent blotching when staining softwoods, use a half-pound cut of shellac as a conditioner before you stain.

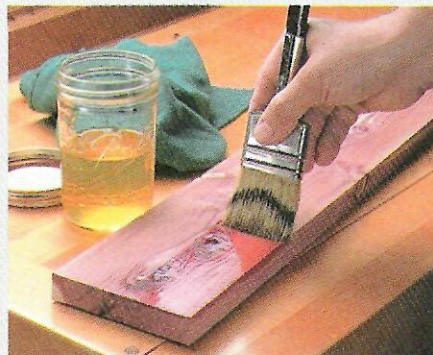

Sealer. Applying a two-pound cut of shellac to wood that has a lot of knots will seal in resins or sap that can bleed through and ruin a finish.



Repairs. Shellac is compatible with most finishes, so it's ideal for repairing damage. Just use shellac that's close in color and dab it into the scratch.

ROUTING CHAMFERS

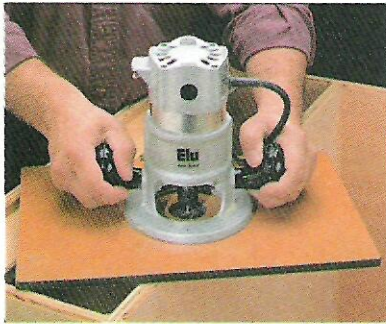

Routing a chamfer on the edge of a project *after* it's assembled can be a challenge. Especially if there's only a thin edge to support the base of the router. In this case, it's all too easy to tip the router and gouge the workpiece.

So when routing the chamfers on the miter saw station shown on page 6, Steve (our shop manager) used a couple different methods to hold the router steady.

INSERT. One of the simplest ways is to use the insert from the router table as a support. To make this work, the insert needs to straddle at least *two* edges of the cabinet, see photo above and drawing A below. This works best when you're chamfering the edges around the opening at the top of the case.

But using the insert for the lower part of the case doesn't work. The insert is too small to

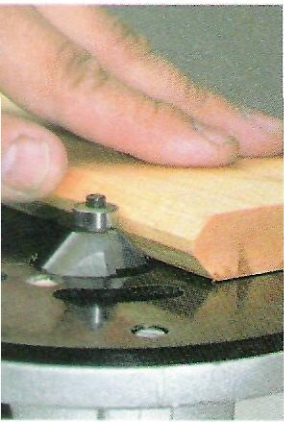

Chamfer Gauge. A scrap block with pre-cut chamfers makes it easy to set the height of the chamfer bit.

CUTTING METAL

When cutting the metal bars for the grinding jig on page 16, I ran into a couple of problems.

First, the bars had to be clamped securely in a vise without marring the surface. And second, the thin metal blade on the hack saw flexed, so it was hard to get a straight cut.

A simple solution to both problems is to pinch the metal bars between two scraps that are tightened in a vise, see photo.

A V-shaped groove in each block keeps the round metal rod from spinning. And straight



grooves hold the square bar, see drawing below.

KERFS. To provide a guide for the blade of the hack saw, just cut narrow kerfs in the blocks. The two 90° kerfs are for making square cuts. The angled kerf is for cutting a bevel.

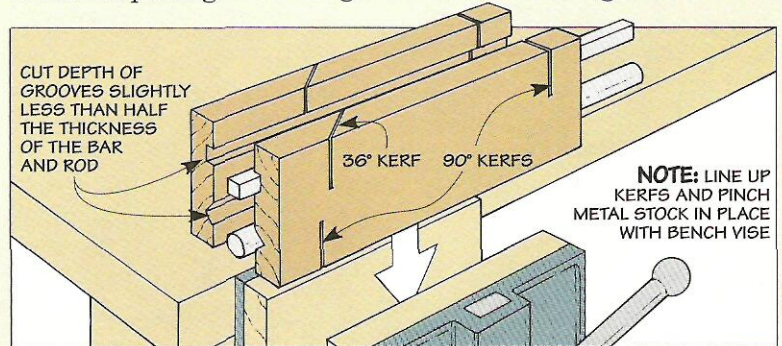

Cutting a metal bar (or rod) is easy when you use a vise to pinch them between two scraps.

Grooves hold the metal pieces securely in place. And narrow kerfs guide the hack saw blade.

span the opening.

SCRAP SUPPORT. So here, it's best to build up the thickness of the edge by clamping a scrap to the case, see drawing B. This provides a wide support for the base of the router so it won't tip as you rout the chamfer.

CHAMFER GAUGE. No matter which method he uses, Steve keeps a chamfer gauge handy to set the height of the router bit, see margin. This way, he doesn't have to spend a lot of time making test cuts in scrap stock to check the height of the bit.

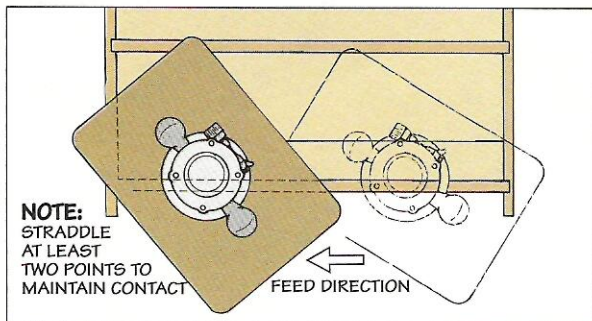

A. Insert. By spanning the opening at the top of the case, the insert that's used to mount a router in a table provides a large, stable support.

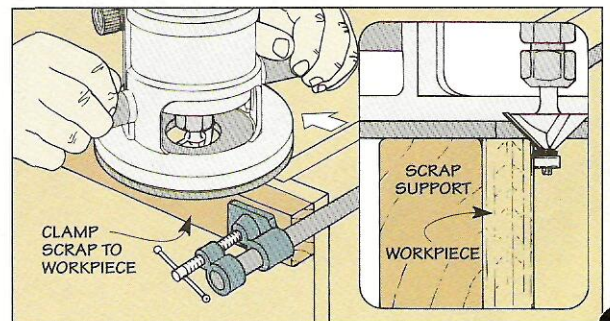

B. Scrap Support. To add extra support that keeps the router from tipping on a narrow edge, clamp a scrap board to the side of the case.

TAPPING THREADS

When making the metal parts for the grinding jig, you'll also need to drill and tap several holes to accept machine screws. This is just a matter of using an ordinary tap to cut the threads and following a simple step-by-step procedure.

LAYOUT. Start by marking the location of each hole. To keep the bit from wandering as you drill, you'll need to make a dimple with a metal punch, see Step 1.

DRILL HOLE. Once you've established a starting point, you're ready to drill the hole. To keep the bit from heating up and breaking, it's best to drill a series of progressively larger holes, see Step 2.

The final size of the hole should be slightly *smaller* than the diameter of the tap. This leaves enough material for the tap to cut the threads.

I used three different size bits ($\frac{5}{64}$ ", $\frac{7}{64}$ ", and $\frac{9}{64}$ ") and added a

drop or two of oil as I drilled. This way, the bits cut smoothly, with less heat build-up. To keep the bar from spinning, clamp one of the scrap blocks (used earlier) to the drill press table and fit the bar in the groove.

CHAMFER. Before tapping the holes, there's one more thing to do. To help center the tap, I cut a slight chamfer in the rim of the hole, see Step 3.

TAP THREADS. Now it's just a matter of selecting the correct size tap (I used an 8-32 tap). After tightening the tap in a T-handled wrench, add a few drops of oil to make it cut easier, see Step 4.

The goal here is to start the tap straight. This way, the tap won't bind as you cut the threads.

Then, with a little downward pressure, rotate the tap clockwise about a half-turn until it starts to cut, see Step 5.

After the tap cuts a few



threads, back it off to remove the waste. While it's tempting to cut the threads all the way down, this puts a lot of stress on the tap. And there's a chance it could break. So just repeat this process of cutting about a half-turn and backing off the tap until all the threads are cut.

CLEAN-UP. Finally, run the tap down the hole a couple of times. This cleans up the threads and clears the shavings from the hole.

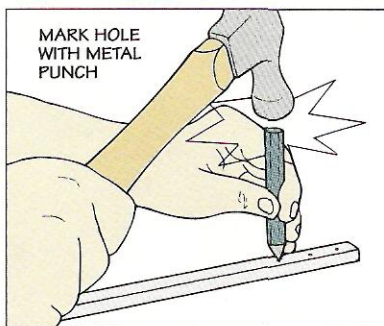

Step 1. To prevent the bit from wandering, use a metal punch to create a dimple in the bar.

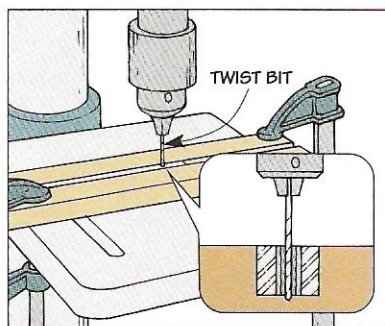

Step 2. Start by drilling a small ($\frac{5}{64}$ ") hole. Then drill a series of larger holes up to $\frac{9}{64}$ " .

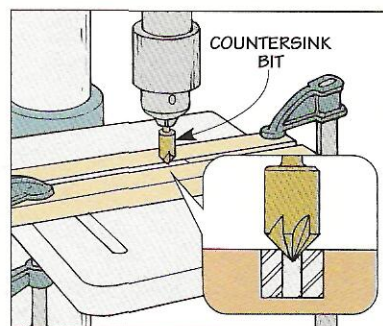

Step 3. To help center the tap, use a countersink bit to cut a slight chamfer around the rim of the hole.

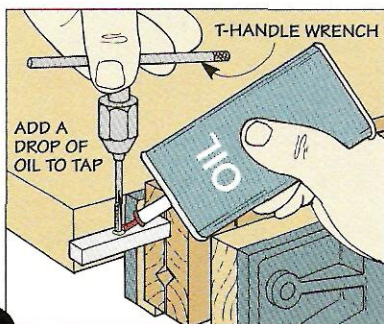

Step 4. Now position the tap so it's straight up and down and add a few drops of oil.

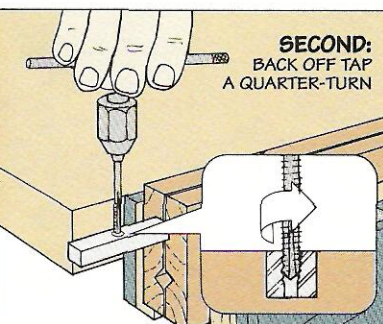
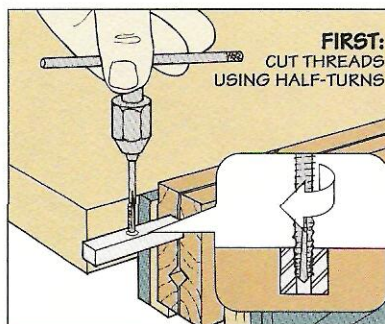

Step 5. With the tap straight up and down, begin cutting the threads (left). After each half-turn, back off the tap to clear the waste (right). Then repeat the process until the threads are cut all the way down.

Scenes from the Shop

Built in the early part of ► the century by the Luther Manufacturing Company, this grinder was pedaled like a bicycle to maintain a keen edge on a tool. Also known as the "Hummer," it was geared low. So with a surprisingly little amount of effort, you could spin the grinding wheels at high speed — fast enough that you'd want to wear a leather apron as protection against a shower of sparks.

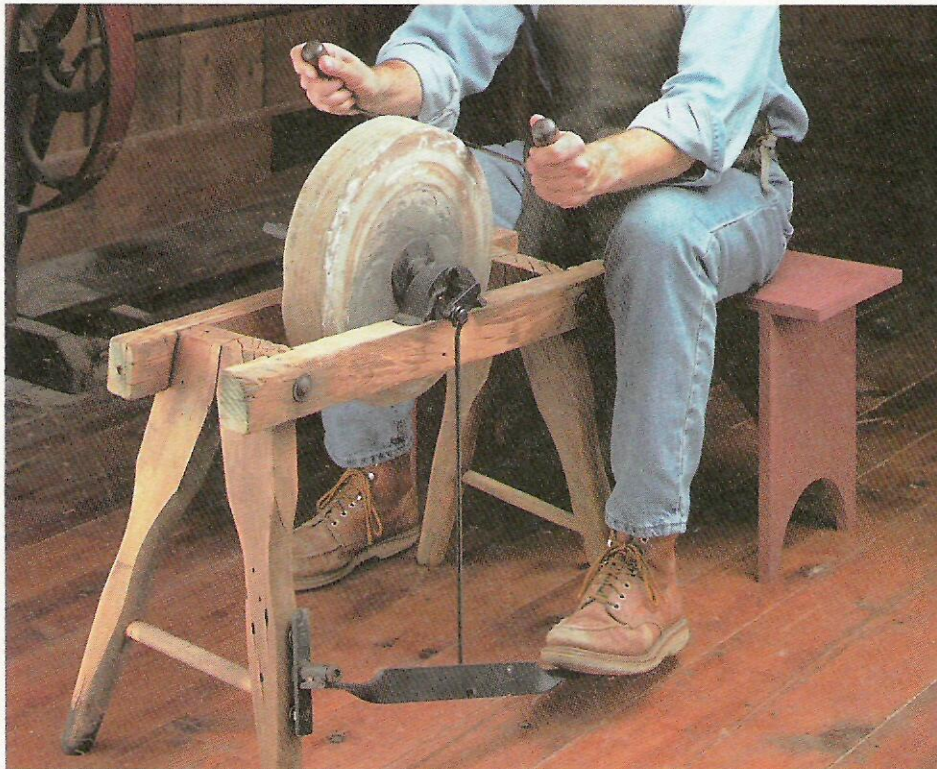

◀ Another forerunner of today's power grinders, this grinding wheel has a massive stone that's turned by stepping on a foot pedal. With a simple metal rod connecting the pedal to a center shaft, this grinding stone rotated at a considerably slower speed than the ones above. But like the low-speed grinding jig shown on page 16, it provided excellent control over the sharpening process.