

TIPS • TOOLS • TECHNIQUES

# ShopNotes®

Vol. 7

Issue 40

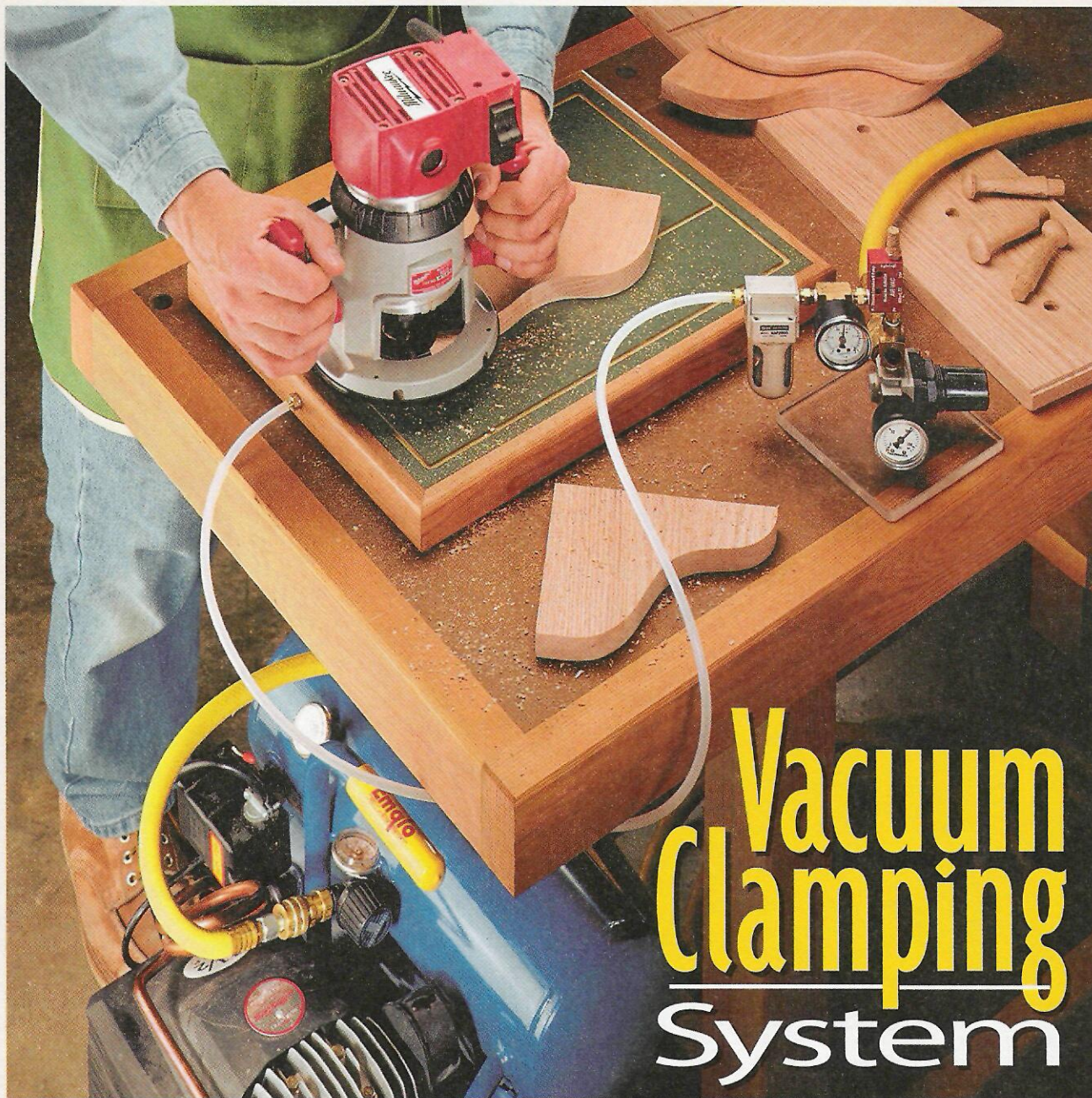

- Router Tenoning Jig
- Vacuum Veneer Press
- Files and Rasps
- Shop-Built Support Stand



# ShopNotes®

Issue 40

July 1998

**PUBLISHER** Donald B. Peschke

**EDITOR** Tim Robertson

**ASSOCIATE EDITOR** Tom Begnal

**ASSISTANT EDITOR** Bryan Nelson

**ART DIRECTOR** Cary Christensen

**SR. GRAPHIC DESIGNER** Kurt Schultz

**SENIOR ILLUSTRATORS** Roger Reiland  
Mark Higdon

## CREATIVE RESOURCES

*Creative Director:* Ted Kralicek • *Project Developer:* Ken Munkel • *Project Designer:* Kevin Boyle • *Project Coordinator:* Kent Welsh • *Shop Mgr.:* Steve Curtis • *Shop Craftsman:* Steve Johnson • *Photography Director:* Lark Smothermon • *Sr. Photographer:* Crayola England

## BOOKS

*Executive Editor:* Douglas L. Hicks • *Senior Graphic Designer:* Chris Glowacki

## CIRCULATION

*Sub. Serv. Dir.:* Sandy Baum • *New Bus. Dir.:* Glenda Battles • *Renewal Mgr.:* Paige Rogers • *Billing Mgr.:* Rebecca Cunningham • *Prom. Mgr.:* Rick Junkins • *New Bus. Mgr.:* Todd L. Bierle • *Asst. Sub. Mgr.:* Joy Krause • *Assoc. Graphic Design Dir.:* Susie Rider • *Sr. Graphic Designer:* Cheryl L. Simpson

## CORPORATE SERVICES

*V.P. of Planning & Finance:* Jon Macarthy • *Controller:* Robin Hutchinson • *Sr. Acct.:* Laura Thomas • *Accts. Payable:* Mary Schultz • *Accts. Rec.:* Margo Petrus • *Prod. Dir.:* George Chmielarz • *Elect. Pub.:* Douglas M. Lidster • *Prod. Asst.:* Susan Dickman • *Pre-Press Image Spec.:* Troy Clark, Minnette Bieghler • *New Media Mgr.:* Gordon C. Gaippe • *Multimedia Art Dir.:* Eugene Pedersen • *Network Admin.:* Chris Harrison • *H. R. Asst.:* Kirsten Koele • *Admin. Asst.:* Julia Fish • *Recept.:* Jeanne Johnson, Sheryl Ribbey • *Bldg. Maint.:* Ken Griffith • *Special Proj. Dir.:* Saville H. Inman

## MAIL ORDER

*Operations Dir.:* Bob Baker • *Mat'l's Mgr.:* Mark Mattiussi • *Cust. Service Mgr.:* Jennie Enos • *Warehouse Supr.:* Nancy Johnson • *Buyer:* Linda Jones • *Op. Asst.:* Tammy Aldini • *Tech. Rep.:* Matthew TeRonde • *Cust. Serv. Reps.:* Anna Cox, Tammy Truckenbrod, Adam Best, Nancy Downey, Deborah Rich • *Warehouse:* Sylvia Carey • *Quality Control Technician:* Frank Johnson

ShopNotes® (ISSN 1062-9696) is published bimonthly (Jan., March, May, July, Sept., Nov.) by August Home Publishing, 2200 Grand, Des Moines, IA 50312.

ShopNotes® is a registered trademark of August Home Publishing ©Copyright 1998 by August Home Publishing. All rights reserved.

**Subscriptions:** Single copy: \$4.99. One year subscription (6 issues), \$21.94. Canada/Foreign add \$6 per year.

**Periodicals Postage Paid** at Des Moines, IA and at additional mailing offices.

**Postmaster:** Send change of address to ShopNotes, P.O. Box 37103, Boone, IA 50037-2103.

**Subscription Questions?** Write to: ShopNotes Customer Service, P.O. Box 842, Des Moines, IA 50304-9961. Or call 1-800-333-5854, 8:00 am to 5:00 pm, Central Time, weekdays. FAX 515-283-0447

**E-Mail:** ShopNotes@shopnotes.com

**Internet:** http://www.shopnotes.com

PRINTED IN U.S.A.

## WoodNet™

### NOW ON THE WEB!

- 101 Woodworking Tips Online
- Woodworking Techniques — Step-by-Step
- Project plans you can download
- WoodNet Forum — Woodworkers' Q & A
- Power Tool Reviews

Point your browser to: <http://www.augusthome.com>  
Select "Woodworking" from the Welcome Page menu.

Reprinted 2002

# Cutoffs

**I**t was quite an unusual looking apparatus — something you'd be more likely to find in a science lab than a woodworking shop.

Made up of gauges, valves, and brass fittings, the entire assembly was mounted to a plastic base, see photo below. Running out of the side of this assembly, there was a long, flexible tube about as big around as a drinking straw.

The end of this plastic tube was hooked up to what appeared to be an ordinary push block. But when I tried to lift the push block off the bench, it wouldn't budge. It was stuck tight as if it was nailed down.

"So what's the deal?" I asked Ken. (Ken is our project developer).

"Just part of a little experiment," he said. Then he turned a valve, and the push block released its grip like magic.

**FIVE JIGS.** As it turns out, the push block was one of five simple jigs Ken had been working on. Each one is designed to securely hold a workpiece that's difficult (or impossible) to clamp — like when you're routing a small piece, or sanding a small part on a disk sander.

But the thing that intrigues me about these jigs isn't that they hold a workpiece with an iron grip. It's that they do it *without* using a single clamp.

**VACUUM.** The secret to this extraordinary holding power is a vacuum (the kind that nature abhors). Each jig is designed with a vacuum area that's sealed off from the outside air. By placing a work-

piece over this vacuum area, the outside air presses it firmly against the jig like an invisible "clamp." (Remember sucking the air from a paper cup till it stuck to your face?)

Okay, paper cups are one thing. But how do you go about producing a vacuum that will hold a workpiece when a router bit is chewing into it at 20,000 rpm's?

Well, it's actually easier than it sounds. All you really need is an air compressor and a special valve called a *venturi valve*.

**VENTURI VALVE.** The most amazing thing about a venturi valve is its simplicity. Inside the valve, air from a compressor is funneled past a tiny opening. As the compressed air shoots past the opening, it sucks *outside* air into the valve.

To take advantage of this suction, one end of a tube is connected to the vacuum system. And the other is hooked up to the jig. The suction in the tube draws all the air out of a sealed off area in the jig. And that creates the vacuum. (For more on this vacuum system, see page 16.)

**INDEX.** But the vacuum system isn't the only project we've been working on. We've just completed an updated index for *ShopNotes* and *Woodsmith* magazines. (*Woodsmith* is our companion publication.)

The index provides a complete reference to all the projects and woodworking techniques that have appeared in both *ShopNotes* and *Woodsmith*. If you're interested in purchasing a copy of the index, give us a call at 800-444-7002.



*Tim*

# Contents

## Features

### Router Tenoning Jig \_\_\_\_\_ 6

*This shop-made tenoning jig makes it easy to cut perfect, square-shouldered tenons. All you need is a hand-held router and a straight bit.*

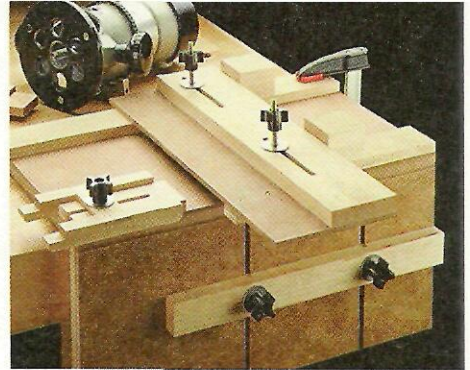

Tenoning Jig page 6

### Files & Rasps \_\_\_\_\_ 12

*Whether you're sharpening a scraper, roughing a workpiece to shape, or smoothing a surface, a basic set of files and rasps is sure to come in handy.*



Files & Rasps page 12

### Vacuum Clamping System \_\_\_\_\_ 16

*A simple valve and an air compressor. That's the key to the extraordinary clamping pressure provided by this vacuum system. It features five simple accessories that use a vacuum to hold small (or difficult to clamp) workpieces securely in place.*

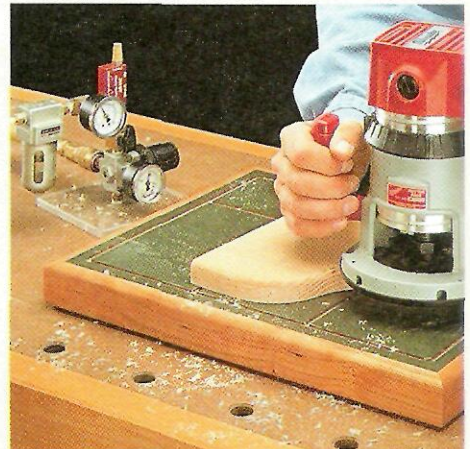

Vacuum Clamping System page 16

### Vacuum Veneer Press \_\_\_\_\_ 24

*Setting up a vacuum system is just a start. By hooking it up to a vacuum bag, you can make a press that applies perfectly uniform pressure — just what you need to veneer flat panels or tricky curved surfaces.*

### Roll-Around Support Stand \_\_\_\_\_ 26

*A telescoping post lets you raise and lower the head of this support stand to match the height of your tools. And a rock solid base keeps it from tipping.*

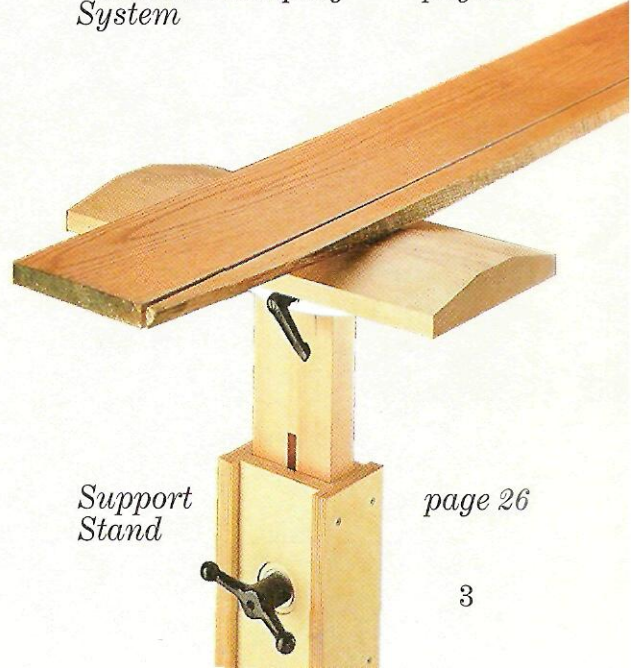

Support Stand page 26

## Departments

### Readers' Tips \_\_\_\_\_ 4

*Our readers offer their own shop-tested tips to some of the most common woodworking problems.*

### Shop Solutions \_\_\_\_\_ 14

*Tips from the guys in our shop that are sure to come in handy when building the projects in this issue.*

### Sources \_\_\_\_\_ 31

*Hardware, supplies, and mail-order sources for the projects featured in this issue.*

# Readers' Tips

## Vacuum Hose Bracket



■ The drum sander on my drill press produces lots of dust. To collect the dust, I slip the hose on my shop vacuum into a bracket attached to the column of the drill press, see photo.

Besides keeping the hose from flopping around on the drill press table, the bracket is easy to adjust. So I can put the end of

the hose right where I want it.

The bracket consists of two parts. A keyhole-shaped *yoke* made from  $\frac{3}{4}$ "-thick stock holds the hose, see drawing. And a metal *hose clamp* secures the yoke to the column.

These parts are held together with a carriage bolt and wing nut. The bolt passes through a hole in the hose clamp and into another hole in the end of the yoke.

Note: The hole in the clamp is slightly *larger* than the square shoulder of the bolt. This lets you tilt the yoke to the desired angle without loosening the wing nut.

To provide clearance for the wing nut, there's a rectangular opening in the yoke. And a large hole is sized to accept the hose.

R.B. Himes  
Vienna, Ohio

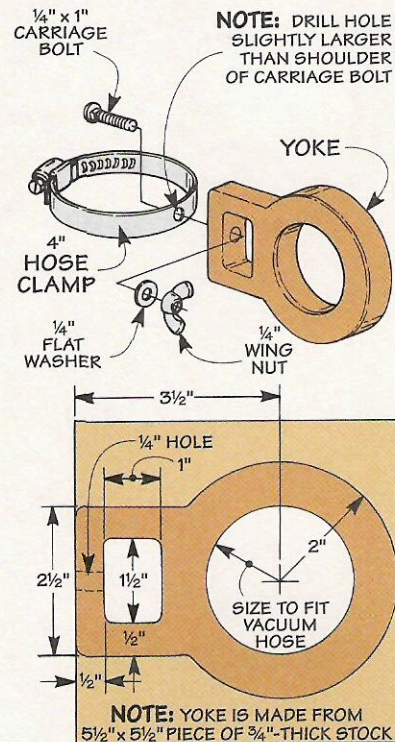

## Clamp Blocks

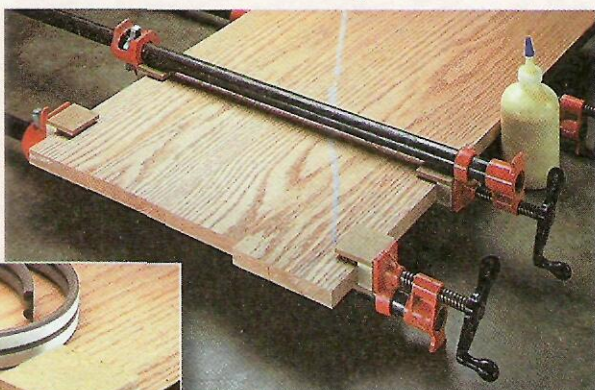

■ When edge gluing boards, I use scrap blocks to distribute the clamping pressure and avoid denting the edges. But sometimes the blocks fall to the floor before I get the clamps tightened.

To solve the problem, I made a number of U-shaped clamp blocks

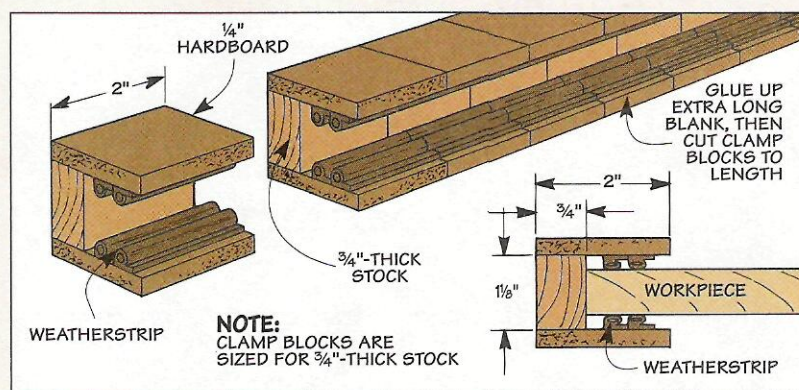

that stay right where I put them. The secret is a piece of self-adhesive weatherstrip attached to the "jaws" of each block, see inset.

When you slip the block over the edge of the workpiece, it compresses the weatherstrip, see drawing. This provides just

the right amount of resistance to hold the block in place.

To make the clamp blocks, it's easiest to glue up a long blank. Then just cut the individual clamp blocks to length.

John Saunders  
Portland, Oregon

## Quick Tips

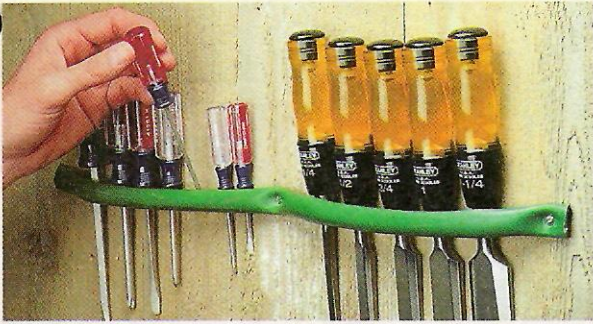

▲ A length of garden hose screwed to the wall provides **Ed Adams** of Dayton, OH with a handy tool rack. The hose holds each tool firmly in place. Yet it's easy to remove a tool or put one back.



▲ Rather than toss out his old leather belt, **Al Finn** of Kent, OH recycled it into a sharpening stropp. With a length of belt glued (rough side up) to a wood handle, he can polish a knife to razor sharpness.

## Cutting Threaded Rod

■ Like many woodworkers, I frequently need to cut short pieces of threaded rod when making a jig. But that's often easier said than done.

One reason is the rod has to be clamped in a vise to keep it from spinning. But using a metal vise will damage the threads. And the jaws of a woodworking vise will get chewed up if you don't use scrap pieces to protect them.

Even when the rod is tightened down, the unsupported part that sticks out of the vise still tends to vibrate as you make a cut. This can cause the saw to chatter or bind.

Fortunately, there's an easy way to avoid all this fussing around. To hold the threaded rod in place, I use a simple block of

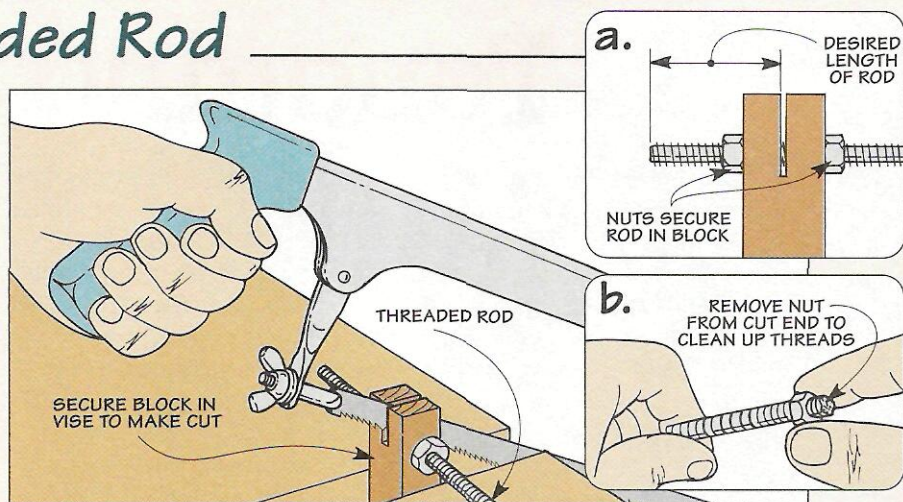

wood that's tightened in a vise, see drawing. The rod passes through a hole drilled near the end of the block. And a thin kerf guides the saw blade.

To prevent the rod from spinning as you make a cut, thread a nut on each end so it's snug (not

tight) against the block, see detail 'a.' The nut remaining on the cutoff piece can be used to clean up the threads damaged by the saw. To "recut" the threads, just remove the nut, see detail 'b.'

*Dan Harlan  
Rochester, Minnesota*

## Layout Tip

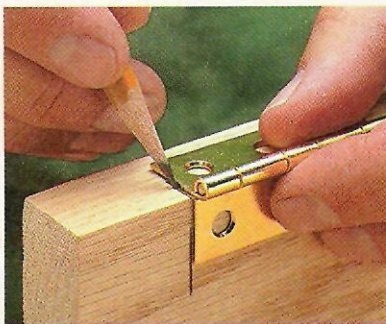

■ To transfer a layout line from one face of a board to an adjacent edge, I use an ordinary butt hinge as a "square," see photo.

This eliminates the guesswork that's sometimes involved when using a try square. And it's quick and accurate as well.

*Adam Roberts  
Chicago, Illinois*

## Send in Your Tips

To share your original tips and solutions to problems you've faced, send them to: *ShopNotes*, Attn.: Readers' Tips, 2200 Grand Ave., Des Moines, IA 50312. (Or if it's easier, FAX them to us at: 515-282-6741.)

We'll pay up to \$200 depending on the published length. Please include a daytime phone number so we can call you if we have any questions.

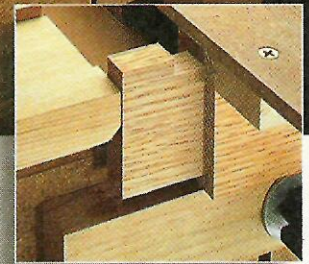
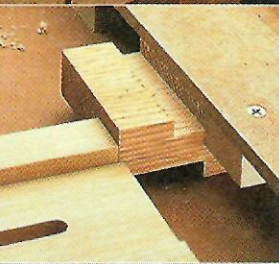
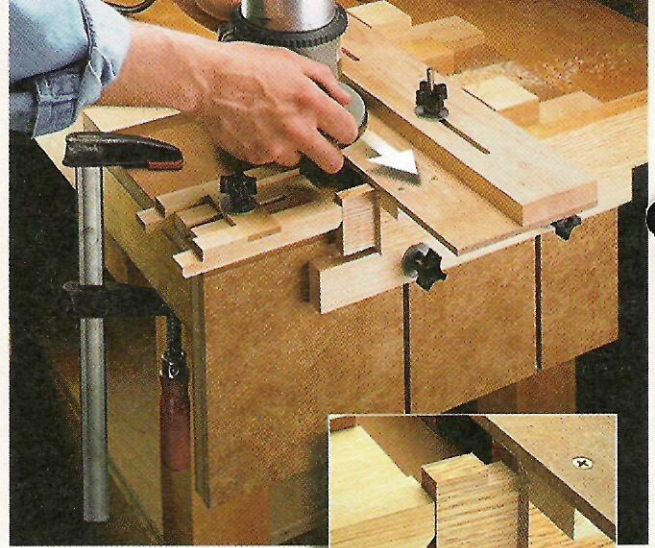
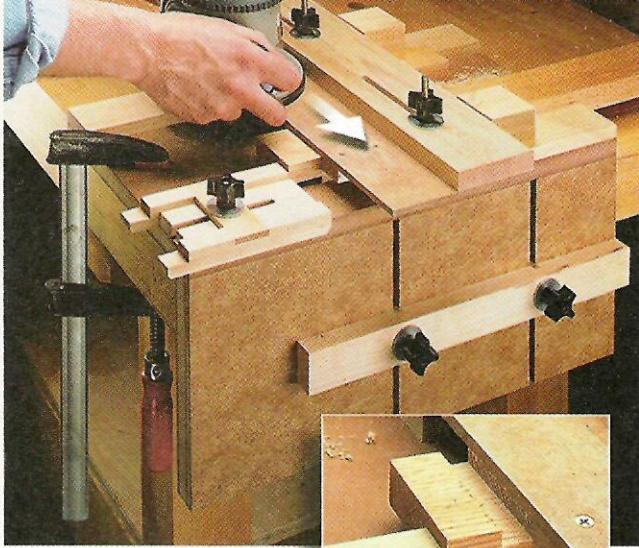

# Router Tenoning Jig

*All you need is a router and this simple jig to rout tenons quickly and accurately.*

The project I'd been working on was coming along nicely. But the next step presented a real challenge — cutting a tenon on the ends of several long rails. Since these rails would hang over the side of the table saw, I'd have to rig up a support to keep them from tipping. And even

then, they would still be awkward to handle — long pieces always seem to twist away from the miter gauge when making a cut.

So I took a different approach altogether. Instead of using the table saw, I made a simple jig which made it easy to *route* the tenons with a hand-held router.

**TWO CUTS IN ONE.** The nice thing about this jig is it provides a way

to cut *both* parts of the tenon. To cut the wide part (the cheek), the workpiece is held flat in the top part of the jig, see photos above left. And the cuts on the edge are made with the workpiece placed against the side of the jig, see photos above right.

In both cases, the workpiece is fixed while the router is guided along a fence. Because of this, there's no limit to the length of a piece you can rout. And the jig can handle stock up to  $5\frac{3}{4}$ " wide.

**SHORT PIECES.** One more note. As I was routing the tenons on my rails, I realized it would be a shame to use this jig for long pieces only. With its easy setup and accurate results, it's ideal for routing tenons on short pieces too.

## BASE

The foundation of the jig is an L-shaped base that clamps to the bench, see drawing.

**TOP.** I began by making the *top* (A) of the base from  $\frac{3}{4}$ " MDF, see Fig. 1. The top provides a flat, stable surface for the workpiece when routing the cheeks.

**SIDE.** After cutting the top to size, the next step is to add a two-part *side*, see Fig. 1. To guide a

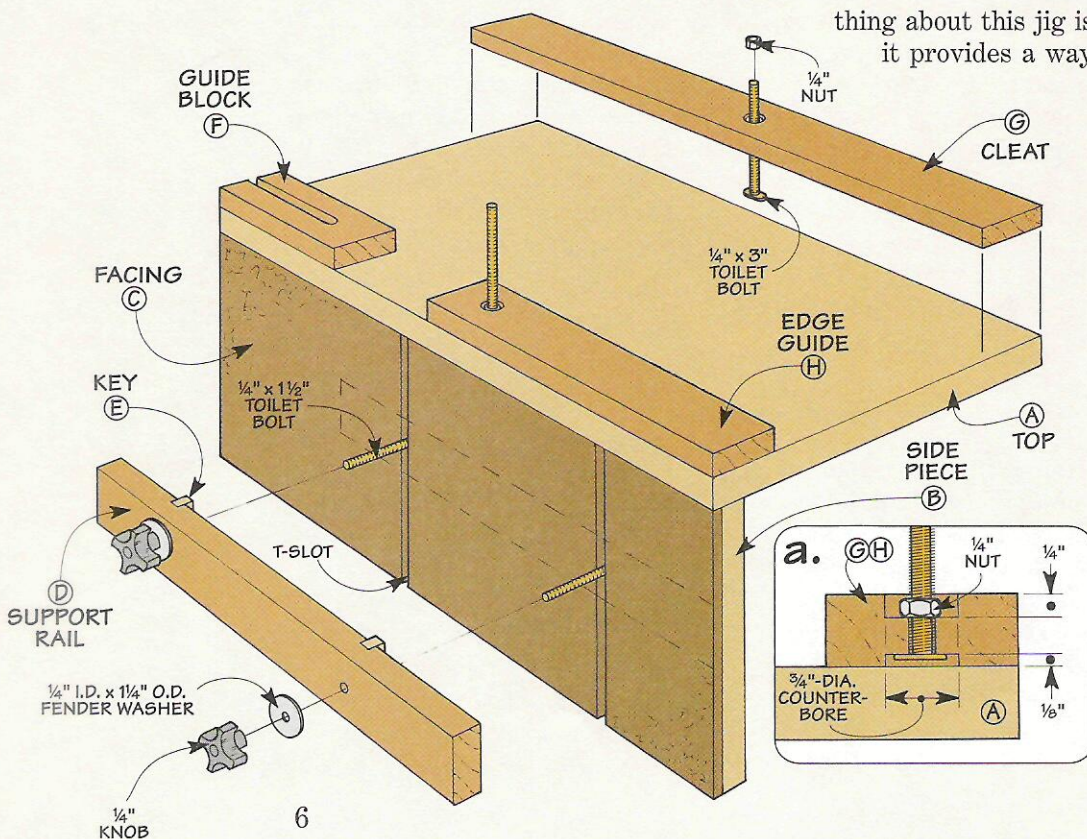

support rail (added later), the side has two T-shaped slots.

An easy way to make these T-slots is to start by cutting a pair of wide dados in a *side piece* (B). Then glue on a hardboard *facing* (C) and complete the slots by cutting narrow dados centered on the ones below, see Fig. 1a.

**SUPPORT RAIL.** After screwing the side and top together, I added a hardwood *support rail* (D), see Fig. 2. It holds up the workpiece when making the cuts on the edge.

To accommodate pieces of different widths, the support rail slides up and down the T-slots in the base. Two hardwood *keys* (E) glued into dados in the support rail keep it aligned.

The support rail is held in place with toilet bolts and plastic knobs. The head of each bolt fits in the T-slot, see Fig. 2a. And the shank passes through a hole drilled through the key and support rail. Tightening a knob on the bolt pulls the head against the facing (C) and locks the rail.

**NARROW STRIPS**

After screwing the side to the top, I added three narrow strips of hardwood. They provide the groundwork for a stop and fence that are added later. Note: I made all three strips from two 1/2"-thick blanks, see Fig. 3

**GUIDE BLOCK.** To keep the stop aligned, a *guide block* (F) is

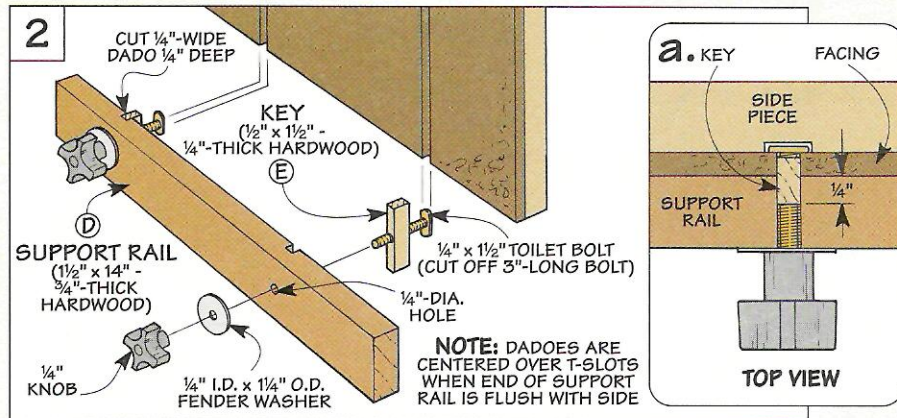
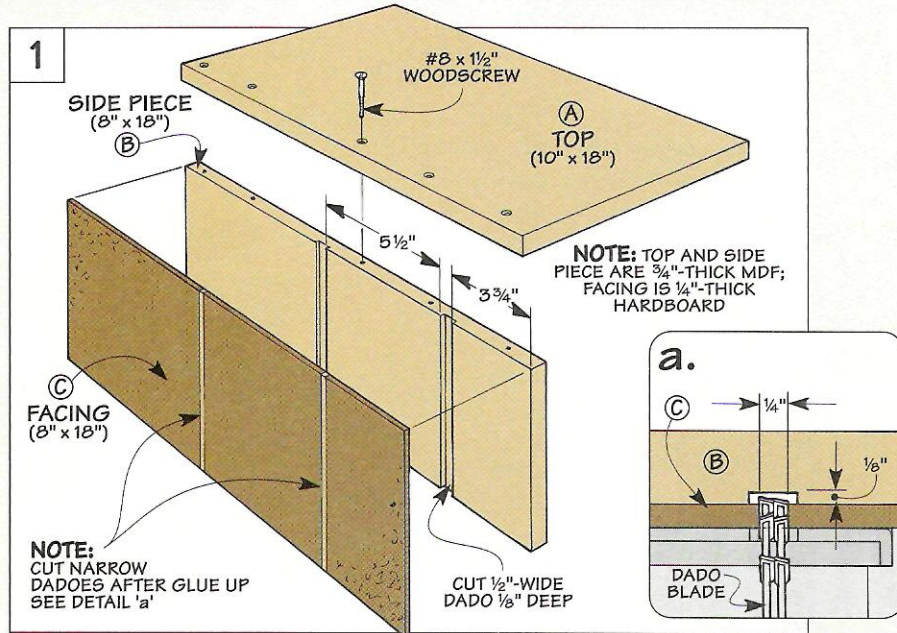

attached to a corner of the base. Here again, a T-shaped slot in the guide block makes the stop adjustable. But this time, I routed the slot using two different size straight bits in the router table. Safety Note: To

avoid working with a small piece, I routed the slot in one of the long blanks and then cut the block to length, see Fig. 3.

**CLEAT & EDGE GUIDE.** In addition to the guide block, I also added a *cleat* (G) and *edge guide* (H). Both parts are used to locate the fence on the base. And the edge guide positions the workpiece so it's square to the fence.

To hold the fence in place, there's a toilet bolt anchored in the cleat and edge guide, see detail 'a' on page 6. The head of each bolt fits in a counterbore in the bottom of the cleats. And a counterbore on top creates a "pocket" for a nut that secures the bolt.

After installing the bolts, it's just a matter of gluing the cleat and edge guide in place.

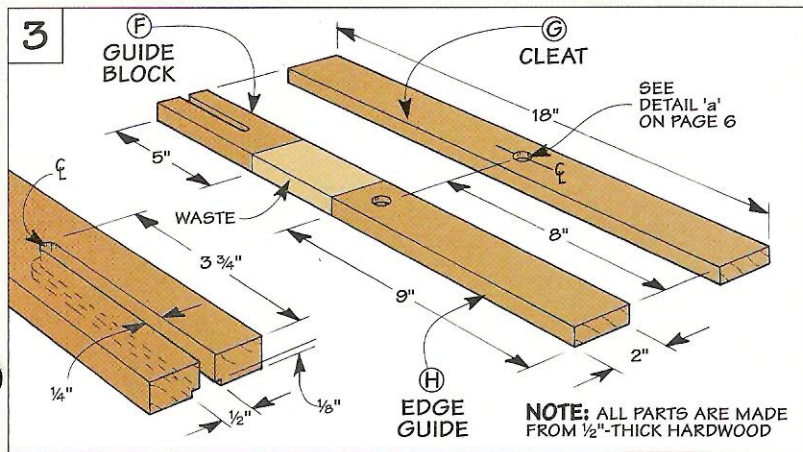

**Hardware**

- (5) #8 x 1 1/2" Fh Wood screws
- (2) #6 x 5/8" Fh Brass Wood screws
- (5) 1/4" x 3" Toilet Bolts
- (5) 1/4" Knobs
- (5) 1/4" x 1/4" Fender Washers
- (2) 1/4" Nuts

# Fence System

The heart of the Tenoning Jig is a sliding fence system that guides the router as you make a cut.

**PLATFORM.** To support the base of the router, it rides on a hardboard *platform* (I), see Fig. 4. This platform is cut to final length. But it's extra wide to start.

**FENCE.** Before trimming it to width, I glued on a hardwood *fence* (J). A pair of slots in the fence (and platform) fit over the toilet bolts in the base. And they allow you to adjust the fence.

**TRIM PLATFORM.** Now you can trim the platform to width. The idea is to use the same bit that will be used to rout the tenons. (I used a 1/2" straight bit.) This creates a *reference edge* that indicates the path of the bit, see Fig. 5.

Note: The bit may not be perfectly centered in the base of the router. So it's best to mark a line on the base where it contacts the fence. Then keep this mark against the fence as you trim the platform to width, see Fig. 5a.

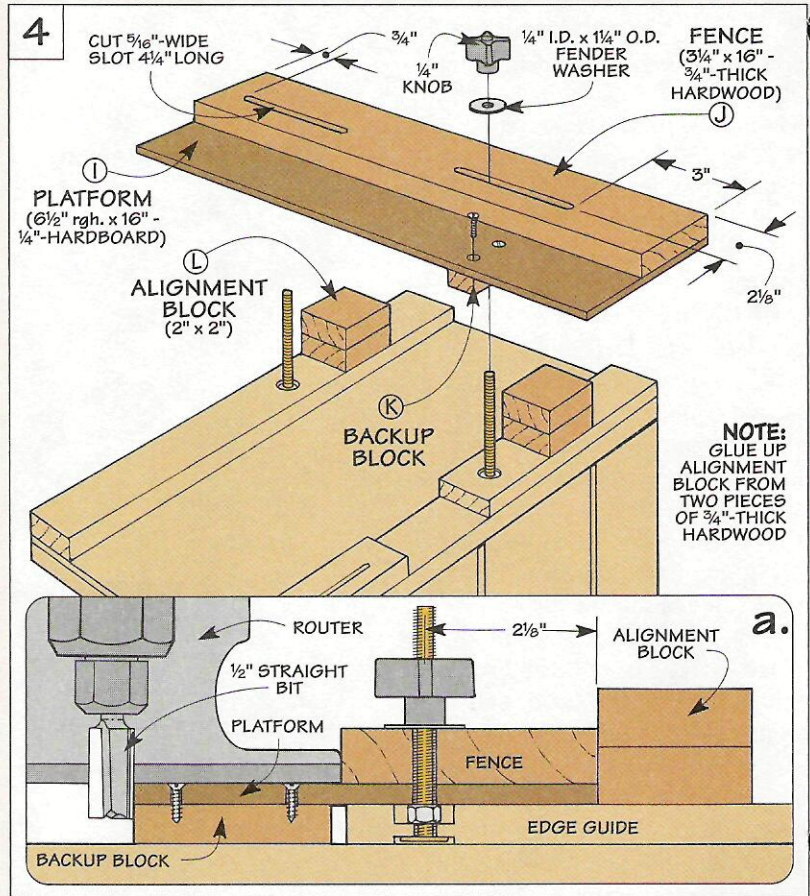

**BACKUP BLOCK.** The next step is to add a *backup block* (K) to the bottom of the platform, see Fig. 6 and margin. This block reduces chipout where the bit cuts through the workpiece.

**ALIGNMENT BLOCKS.** After attaching the backup block with

glue and screws, I added two thick *alignment blocks* (L), see Fig. 4. These blocks keep the fence square to the workpiece. So it's important that the blocks are glued square to the edge guide and that they align with each other, see Fig. 4a.

▲ To reduce chipout, just slide the fence in so a small backup block butts up against the workpiece.

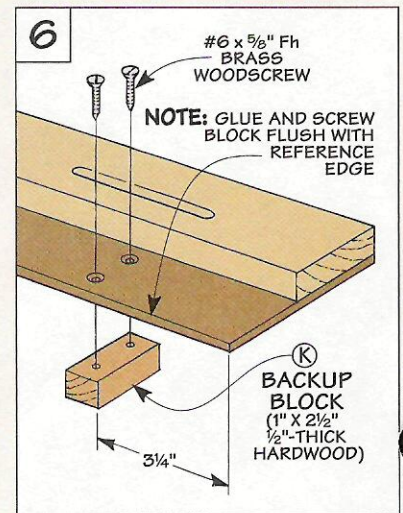
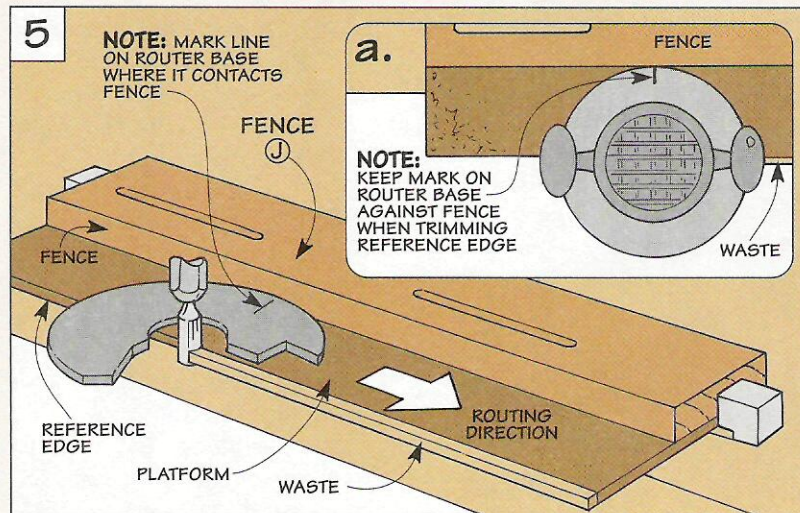



# Adjustable Stop

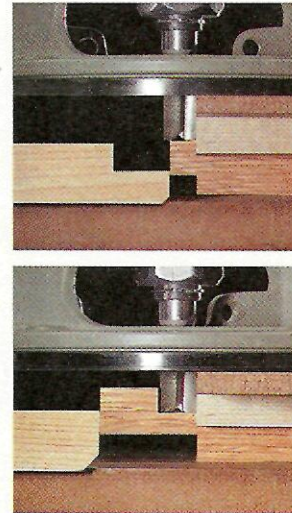
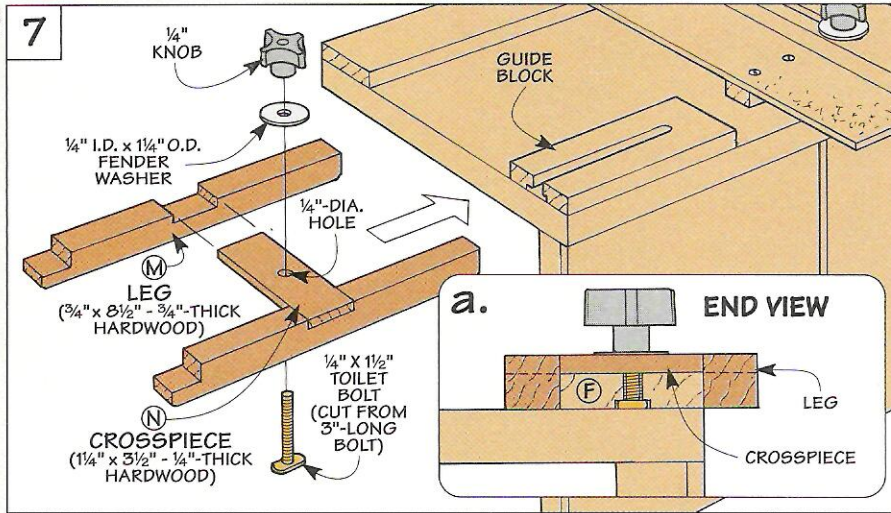

◀ To avoid cutting into the adjustable stop, use the notched ends of the legs when routing short (stub) tenons.

◀ If the tenon is longer than the diameter of the bit, simply turn the stop around and use the thick end of the legs.

To ensure accurate results, I added an adjustable stop that automatically positions the workpiece for each of the shoulder cuts. The stop is an H-shaped assembly that slides over the guide block on the base, see Fig. 7.

The shape of the stop creates two “legs.” When routing the cheek of the tenon, the workpiece butts up against the leg that rests on the base, see Fig. 7a. And when routing the edge, the leg that extends over the base acts as a stop.

But why do you need a *double-ended* stop? The reason has to do

with the *length* of the tenon.

If you’re routing a short (stub) tenon, the router bit will cut into the stop. So on one end, the legs are notched to avoid getting chewed up, see upper photo above. But for long tenons (anything longer than 1/2” if you’re using a 1/2” bit), I use the thick ends of the stop.

**ALIGNMENT.** No matter which end of the stop you’re using, the important thing is that the end of one leg aligns with the end of the other. This ensures that the shoulders of the tenon will be perfectly aligned on all four sides of the workpiece.

**LEGS.** To accomplish this, I made two identical *legs* (M) from a single blank of 3/4”-thick hardwood, see the drawings below. Safety Note: Because of their small size, it’s best to cut the legs from an extra-long blank.

**CROSSPIECE.** The legs are connected with a *crosspiece* (N) made from a thin strip of hardwood, see Fig. 7. Before gluing the legs in place, I drilled a centered hole in the crosspiece to accept another toilet bolt.

After sliding the head of the bolt into the T-slot in the guide block, just tighten a knob on the end to lock the stop in place.

## MAKING THE LEGS

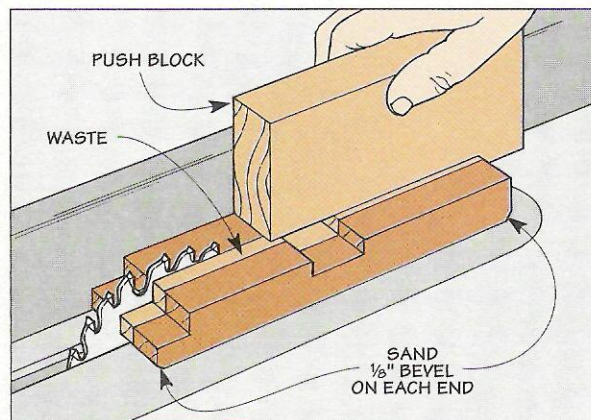
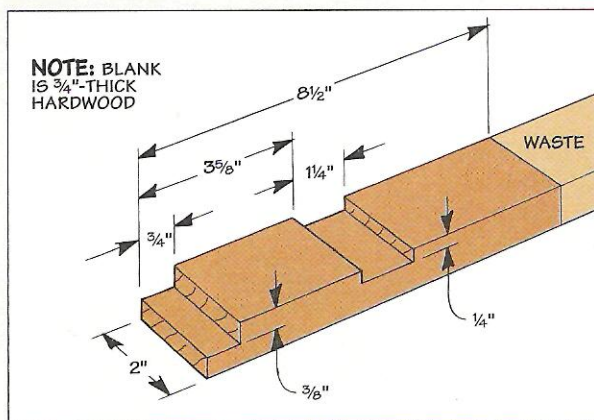

**1** To make two identical legs for the adjustable stop, start by rabbeting one end of an oversize blank. Then cut a wide dado for the crosspiece.

**2** After cutting the legs to length, sand a bevel on each end to provide a relief area for dust. Then rip two narrow strips to form the legs of the stop.

# Using the Jig

One nice thing about this jig is you can set it up and rout a tenon in a matter of minutes. The tenon is routed in a simple two-step process — first the cheeks, then the edges.

## CHEEKS

When routing the cheeks, the workpiece is slid into the end of the jig so it rests flat on the base. Then, with the fence tightened down against it, the tenon is cut by making a series of passes.

**LAYOUT.** To position the workpiece in the jig, you'll need to lay out one of the shoulders of the

tenon. I just make a single line across the *face* of the workpiece.

Even with an accurate layout, it doesn't guarantee a straight, square-shouldered cut. That depends on two things: the position of the workpiece in the jig, and the location of the fence.

**SQUARE UP FENCE.** To produce accurate results, the fence needs to be square to the edge of the workpiece. Fortunately, squaring up the fence is a process that's "built-in" to the design of the jig.

Start by placing the workpiece against the edge guide (H), see Step 1 below. Then butt the fence against the alignment blocks (L). Since the blocks are square to the edge guide, this automati-

cally squares up the fence.

But there's more to routing a tenon than just getting a square cut. The router bit has to cut precisely along the shoulder line.

**ALIGN SHOULDER.** That's where the reference edge on the platform comes in. Since it indicates the path of the bit, you just slide the workpiece one way or the other until the shoulder aligns with the reference edge. This ensures that the bit will cut exactly at the shoulder line.

**BACKUP BLOCK.** As the bit cuts through, it could chip out the edge of the workpiece. But the backup block (K) supports the wood fibers and reduces tearout. To make this work, just slide the

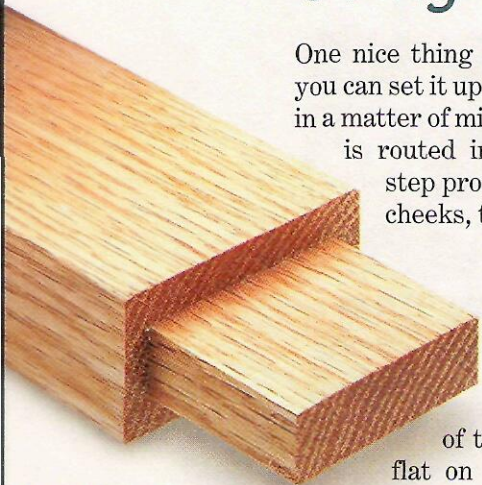

▲ It only takes a few minutes to set up the jig and rout a straight, square-shouldered tenon.

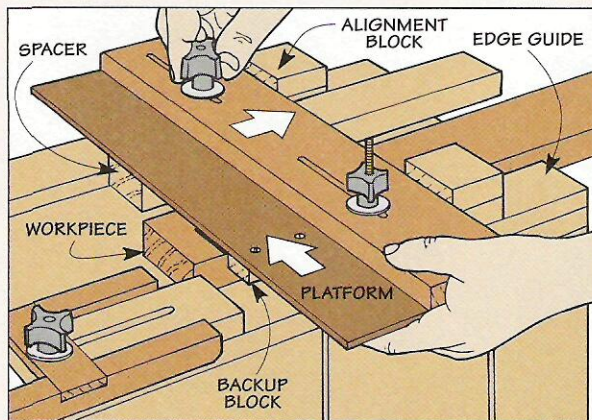

**1** After positioning the workpiece in the jig, slide the fence forward until the backup block butts up against it. Then simply lock the fence in place.

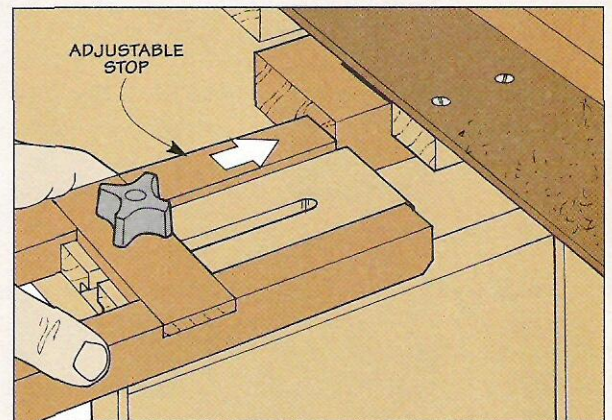

**2** Now slide the adjustable stop against the end of the workpiece and lock it in place. The stop ensures that all four shoulders align.

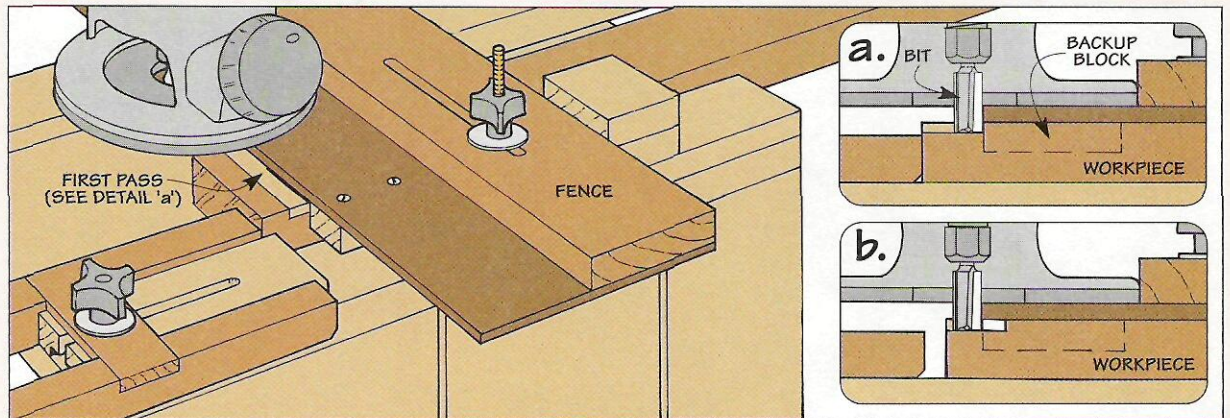

**3** With the base of the router riding against the fence, cut the shoulder of the cheek first, see detail 'a.' If you need to make additional passes to

complete the tenon, loosen the fence and slide the workpiece away from the stop, see detail 'b.' Then flip the workpiece and repeat the process.

fence forward until the block contacts the workpiece.

**ADD SPACER.** Before tightening the fence down, there's one more thing to do. That's to slip a spacer under the unsupported end of the fence. It's just a scrap that's the same thickness as the workpiece. With the spacer in place, the fence applies even pressure on the workpiece as it's tightened down.

**ADJUST STOP.** The fence locks the workpiece in place so you can rout the *first* shoulder. But to get the shoulder on the *opposite* side to align with it, you'll need to return the workpiece to the exact same position in the jig. Sliding the adjustable stop against the end of the workpiece will make it easy to duplicate the

exact setup, see Step 2.

**ROUT CHEEKS.** After adjusting the stop, you're ready to rout the cheeks. Depending on the length of the tenon, this may require several passes, see Step 3.

There are a couple of things to keep in mind when routing the cheeks. First, you'll want to use the same bit that was used to cut the reference edge. And since the bit may not be perfectly centered in the base, keep the same point on the router base in contact with the fence for each pass.

**EDGES**

Once the cheeks are cut, you're halfway done. All that's needed to complete the tenon is to rout the *edges* of the workpiece.

This is accomplished with the

workpiece held flat against the *side* of the jig. Once again, the jig makes it easy to position the workpiece for an accurate cut.

**SUPPORT RAIL.** To do this, set the workpiece on the support rail (D). Then raise the rail until the top edge of the workpiece butts against the platform (I), see Step 4. Note: To keep the fence parallel to the base, I slid a second spacer under the platform before tightening the fence.

Here again, slide the end of the workpiece against the adjustable stop. And check that the backup block is against the workpiece, see Step 5.

**ROUT EDGES.** Now it's just a matter of routing the edges. As with the cheeks, this may require several passes, see Step 6.

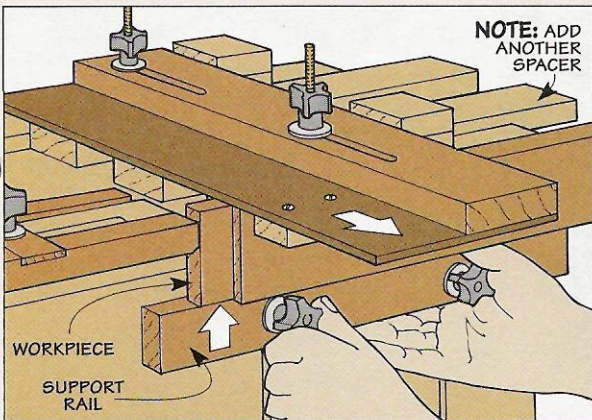

**4** Before you rout the edges, butt the workpiece up against the platform and the stop. Locking the support rail holds the workpiece in place.

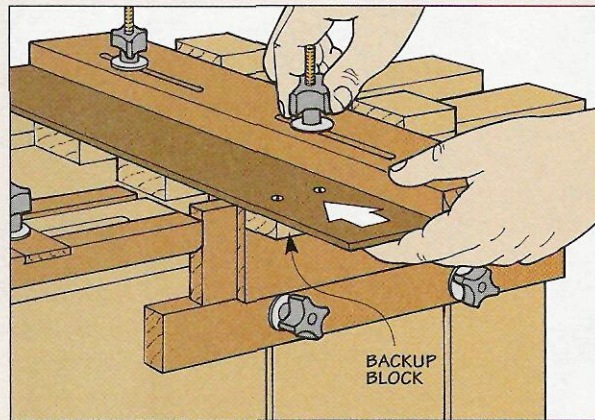

**5** To prevent chipout, slide the fence forward until the backup block contacts the workpiece. Then just tighten the knobs to lock the fence.

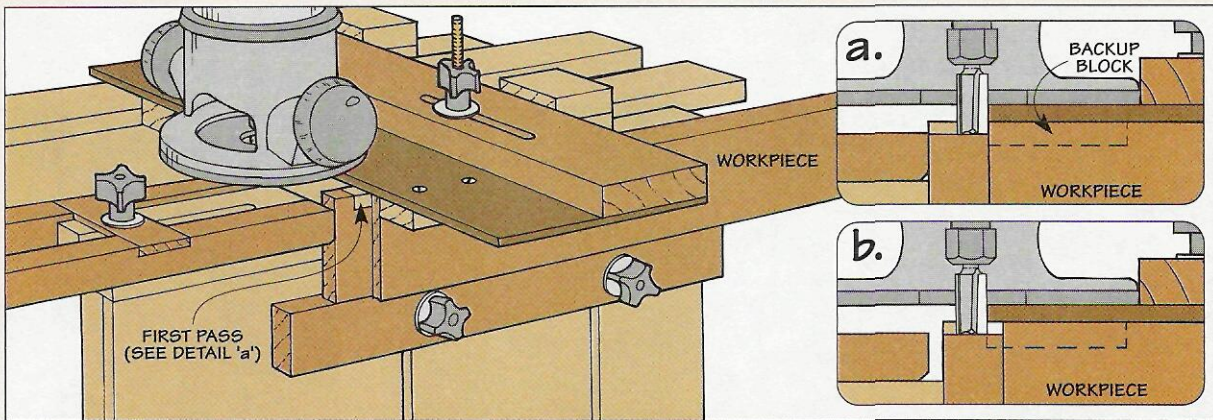

**6** Depending on the length of tenon, it may take several passes to rout the edges. After establishing the shoulder with the first pass (detail 'a'), loosen the fence and slide the workpiece away from the stop for subsequent passes, see detail 'b.' Then repeat the process on the opposite edge.

# Files & Rasps

*Don't overlook these simple hand tools. A basic set of files and rasps makes quick work of many jobs.*



**I**t's just a hunch. But I'd be willing to bet that files and rasps are the most "forgotten" tools in woodworking. Maybe that's why they often end up in the bottom of a toolbox gathering dust (and rust).

But don't sell these simple hand tools short. Whether you're sharpening a scraper, roughing out a curved shape on a workpiece, or just smoothing an edge, a basic set of rasps and files is an incredibly useful addition to your toolbox.

There's only one problem. Files and rasps come in a bewildering variety of shapes, sizes, and types. (There's even a rasp called a "planing rasp," see the box below.)

So which rasps and files do you include in a basic set? To answer that question, you need to understand a bit about how they work.

## RASPS

A rasp removes a lot of material in a hurry. So it's great for shaping a workpiece like a cabriole leg or the curved arm of a chair.

**TEETH.** There's a good reason a rasp cuts so quickly — it has hundreds of sharp, raised teeth,

see the left inset photo above.

These teeth are arranged in parallel rows on wood rasps and cabinet rasps. As a result, these rasps tend to leave grooves in the workpiece like the furrows from a plow.

**PATTERNMAKER'S RASP.** That's why I usually follow up the initial shaping with a special rasp called a *patternmaker's rasp*, see photos below left. With this rasp, the teeth are spread out *randomly*. So you don't have to worry about leaving a trail of grooves to clean up.

The only drawback to a patternmaker's rasp is the price. For example, a 10" Nicholson #49 costs about \$36. But for the smooth, controlled cut it produces, I think it's worth the cost.

## FILES

Even with the smoothest cutting rasp, it still leaves a surface that's a bit rough and "fuzzy." So for final smoothing, I reach for a file.

**CUTTING EDGES.** Unlike a rasp, a file doesn't actually have teeth. Instead it has diagonal rows of *cutting edges*, see right inset photo above. These edges are formed by making diagonal cuts in

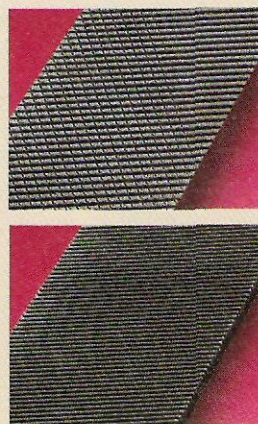

The diamond-shaped cutting edges on a double-cut file (top) remove material more aggressively than a single-cut file (bottom).

▼ **Rasps.** The teeth on a patternmaker's rasp (top photo) are spread randomly across the surface. So it doesn't leave grooves behind like a typical rasp (bottom) where the teeth are lined up in straight rows.

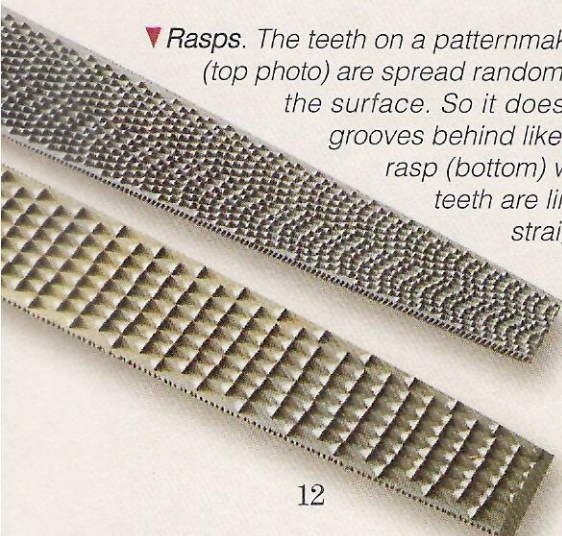

## Planing Rasp

The first time I picked up a *planing rasp*, it felt too lightweight for "serious" woodworking. But I was wrong.

A planing rasp has hundreds of razor-sharp teeth that shred wood quickly and aggressively, see photo. Even so, the teeth won't clog like most rasps, see page 31 for sources.



◀ *Shape.* Flat and half-round files (or rasps) are the real workhorses in my shop. But for getting into tight places or cleaning up a slot, it's handy to have triangular and round files as well.

the file. Because of these cutting edges, a file makes a clean, shearing cut that produces a smooth surface.

**CUT.** The pattern of the cutting edges on a file is called a "cut." A *single-cut* file has a series of diagonal cuts that run in one direction only, see center photos on page 12. But a *double-cut* file has a second set of intersecting cuts that form diamond-shaped cutting edges.

Which "cut" is best? That depends on the job. A double-cut file removes material more quickly on wood. But it's too aggressive for metal. So when sharpening the edge of a cabinet scraper for instance, I use a mill file which has a single cut.

**HOW THEY'RE ALIKE**

In spite of their differences, files and rasps do have some basic things in common. Keeping these things in mind will make it easy to select a set that's most suited to the type of work you do.

**GRADE.** First, you'll need to decide on the grade (coarseness) of the file or rasp. Typically, you'll find three grades: smooth, second-cut, and bastard. Note: These are listed from finest to coarsest.

For most work, I'll use a coarser file or rasp like a second-cut or bastard. They're more readily available. And they don't clog as quickly.

**LENGTH.** But the grade isn't the only thing that affects the coarseness of cut. The *length* of the tool also plays a part. For example, within a single grade, a longer file (or rasp) has larger, coarser teeth than a shorter one. So a 10"-long bastard file is *coarser* than an 8"-long bastard file.

And it gets more confusing

yet. As a rule, you'll find that a file which is one grade *finer* and 2" *longer* has the *same* size teeth. This means that a 10" second-cut file is just as coarse as an 8" bastard file.

**SHAPE.** Besides the grade and length, you also need to decide on the *shape* of the file. Here again, there's a shape for most any job, see photos above.

Note: For a look at the basic set of files and rasps that we use, see the box below.

**CARE & CLEANING**

As with any quality tool, a little preventive maintenance goes a long way in keeping your files and rasps nice and sharp.

**STORAGE.** Even something as simple as the way they're stored can make a difference. Because the steel is heat-treated to make it extremely hard, the teeth will chip if they get banged around. So I store them in a tray with dividers that keep each one separate.

**CLEANING.** With use, a file or rasp will get clogged with dust or debris. Besides preventing it from cutting effectively, this dust accumulates moisture which will cause the metal to rust.

To prevent this, I use a special brush called a *file card* to keep them clean, see photos above right. It has nylon bristles on one side to sweep out the loose dust. And spring steel wires on the other side make it easy to remove any material that gets packed in. 🛠️



*File Card.* Nylon bristles on this file card brush off the loose dust. And steel wires remove material that gets packed in, see inset.

**Files & Rasps — A Basic Set**

There's no need to fill up your toolbox with a bunch of files and rasps. A basic set like the one shown here will handle most any job.

**HANDLES.** Some files and rasps will come with a handle already in place. But if not, adding your own handle will provide a comfortable grip and make them easy to use.

For sources of files and rasps, see page 31.



## TEMPLATE ROUTING

■ To create a vacuum on the surface of the Vacuum Table (page 18), you simply surround the desired area with a strip of foam. This foam fits in grooves routed in the surface of the table, see margin.

For large workpieces, there's a groove running around the perimeter of the table. And for smaller pieces, a gridwork pattern of grooves lets you change the size of the vacuum area by rearranging the foam.

An easy way to rout these grooves is with a hand-held router and a core box bit. To guide the bit, all you need is a template and a guide bushing attached to the base of the router.

▲ Routing the grooves in the vacuum table is easy. All it takes is a template and a hand-held router.

**TEMPLATE.** The template is a piece of 1/4" hardboard attached to the top of the vacuum table, see Fig. 1. When sizing the template, there are a couple of things to keep in mind.

First, the groove around the perimeter is set in 1/2" from the edges of the table. Since you'll be routing all the way around the template, the first step in sizing the template is to subtract 1" (twice that amount) from the length and width of the table.

But remember, it's the guide

## CLAMPING JIG

■ When building the Support Stand on page 24, I used a sabre saw to cut a curve in the pieces of aluminum angle.

But clamping the aluminum can be a problem. If you clamp it in a vise, there's not enough clearance for the saw blade on its downward stroke. And if you clamp the aluminum to a bench so it extends over the end, the saw bounces like a jackhammer.

The solution is to screw the aluminum to a scrap of "two-

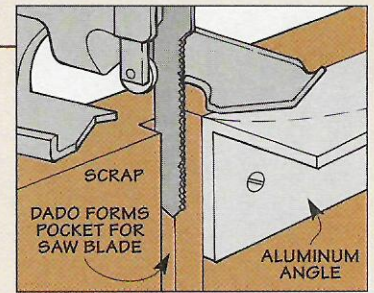

by" material tightened in a vise, see drawing. Two dadoes form pockets for the saw blade. This provides support for the base of the saw at the beginning and end of the cut, see photo.

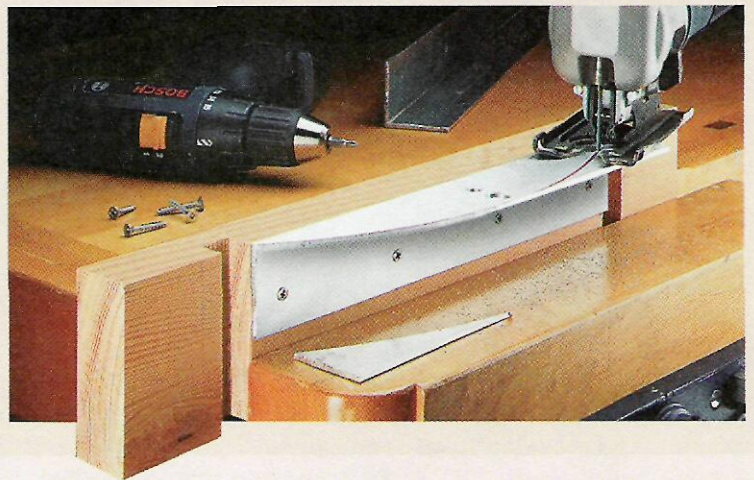

bushing (not the router bit) that rides against the template. So you'll need to figure out the offset as shown in Fig. 1a and subtract it too. Note: You'll need to double the amount of offset as well.

**ROUT GROOVES.** After cutting the template to final size, you're ready to rout the grooves. Start

by attaching the template with carpet tape so it's centered on the table, see Fig. 1. Then rout in a counter-clockwise direction.

To rout the gridwork pattern of grooves, just reposition the template, see Fig. 2. Then rout the grooves working from the longest one to the shortest.

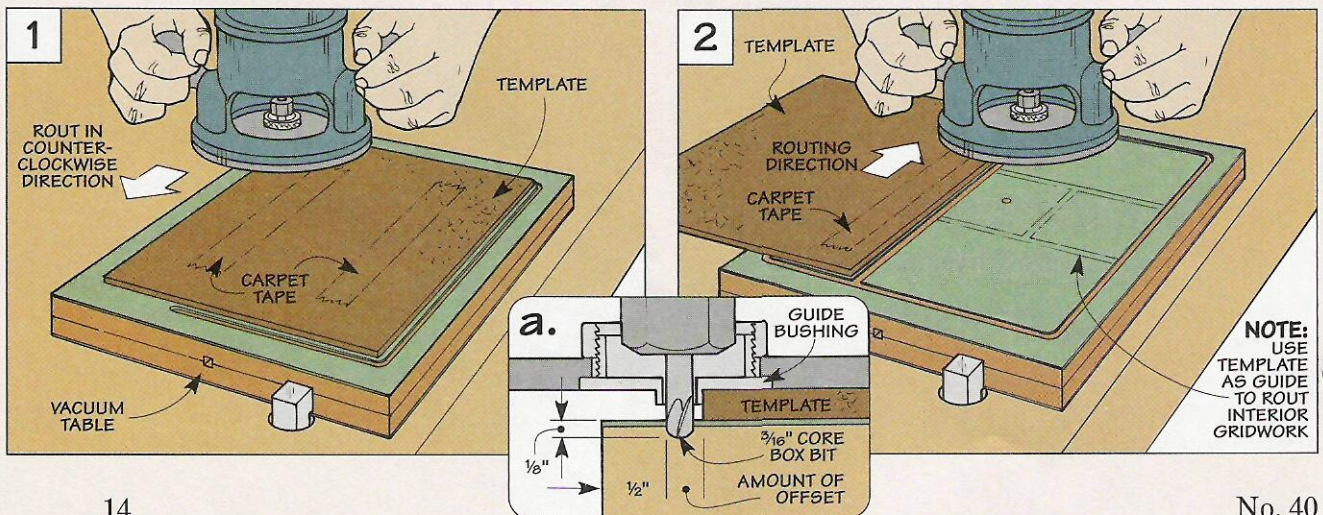

## INDEXING JIG

■ Making the “fingers” of the Featherboard shown on page 22 is easy. The trick is getting each finger spaced evenly apart. To do this, I made a simple indexing jig that attaches to the miter gauge on my table saw, see photo.

The jig consists of two parts. A tall fence provides support for the workpiece, see drawing below. And an *index pin* positions the featherboard to provide consistent spacing between each finger.

**INSTALL PIN.** The index pin is a scrap of 1/8" hardboard that fits in an angled kerf in the fence. After gluing it in place, screw

the fence to the miter gauge so the pin is 1/4" away from the blade (the same width as the fingers).

**CUT KERFS.** To cut the kerfs that form the fingers, start by butting the edge of the workpiece against the index pin. Then, after clamping it to the fence, make a single pass.

Note: Because the blade on my table saw tilts to the right, only the filler block on the featherboard contacted the fence. So to support the upper part of the featherboard, I carpet-taped a scrap to the fence that's the same thickness as the filler block,

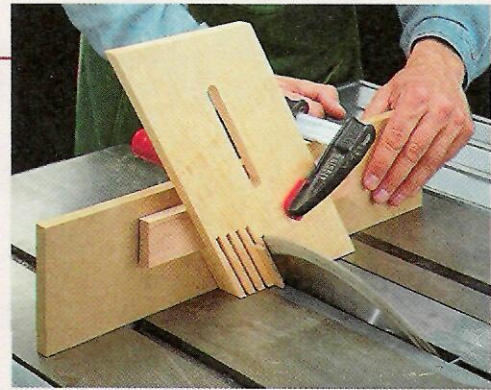

see photo above and detail below.

Once the first kerf is cut, fit it over the index pin. Then reclamp the workpiece and make another pass. To complete all the fingers, just repeat the process.

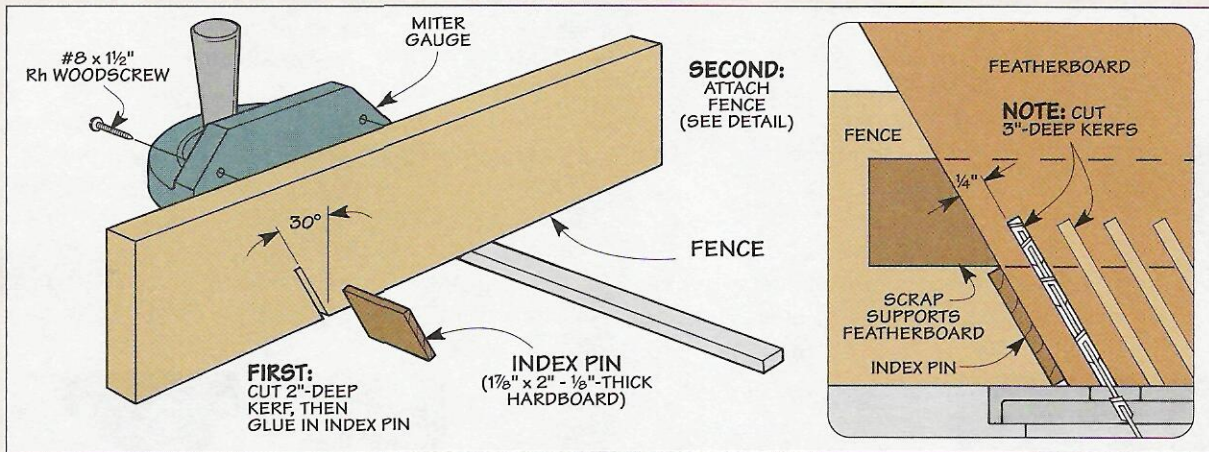

## SHOP-MADE HANDLES

■ The plywood handles for the Small-Piece Jigs (page 20) are fairly small. So to work with them safely, I glued up a large blank that's sized to produce two handles, see Fig. 1.

The curved shape on the *inside* of the handles is formed by

drilling a hole near each corner. And the *outside* corners are simply cut and sanded to match.

The next step is to remove the remaining waste with a bandsaw (or sabre saw), see Fig. 2. Note: To end up with two handles of equal size, make an entry cut

that's centered on one edge. Then after removing the waste, exit at the same place.

To complete the handles, rout a roundover on all the edges, see Fig. 3. Then cut the two handles apart.

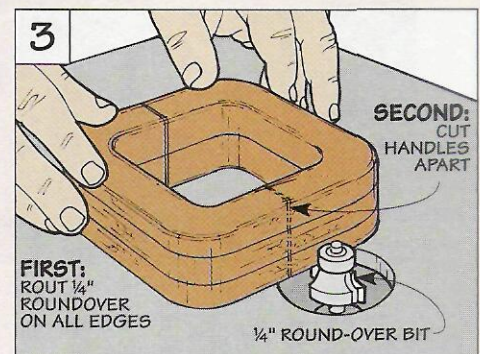
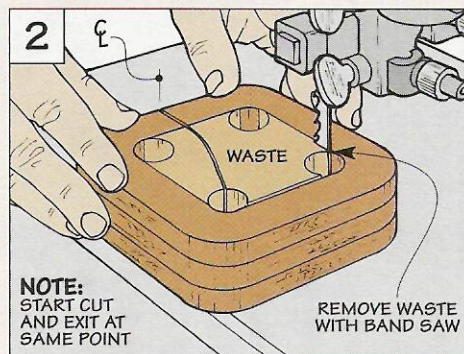
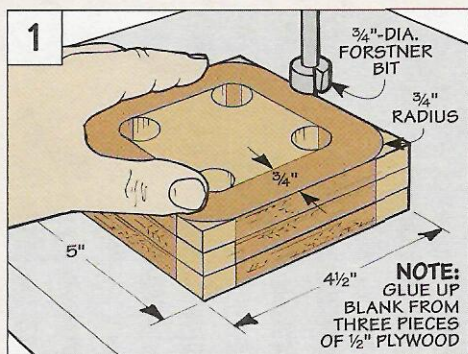
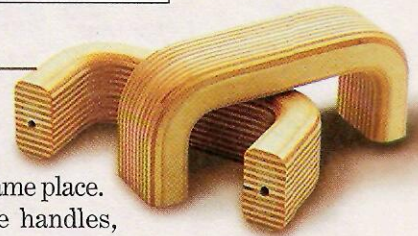

# Vacuum Clamping System

*You can't see it. But it has an iron grip. This invisible "clamp" is the secret to these five simple jigs.*

**I**t was a small, red metal block — no bigger than a bite-size candy bar. And I didn't have a clue what it was for.

"Alright," I said. "I give up. What is it?"  
 "It's a *venturi valve*," said Ken (as if that would make the light bulb come on in my head). "It's used along with an air compressor to create a vacuum."

Well, that helped a little. Even so, it wasn't until I saw the venturi valve hooked up to the *rest* of the system that I began to understand how it worked.

**VACUUM SYSTEM.** The venturi valve is just one part of an assembly that includes a couple of gauges, a shutoff valve, and an air filter; see photo at left and Exploded View on next page. But it's the venturi valve that's the heart of the vacuum system.

Inside the valve, air from the compressor is funneled past a small opening, see detail on page 17. As the air rushes past, it pulls outside air *in* — like the suction created in the wake of a big truck. The air that's drawn in is what creates the vacuum.

**FIVE JIGS & ACCESSORIES.** To work together with the vacuum system, we made five simple jigs and accessories, see photos below. Creating a vacuum in each one allows a workpiece to be held securely in place *without* using a single clamp.

Besides not having any clamps to get in the way, this allows you to work with small pieces that are difficult (or impossible) to clamp otherwise. You just set the workpiece over the vacuum area in the jig. When you apply the vacuum, the outside air presses against it like an invisible clamp.

**AIR-TIGHT SEAL.** The trick is to keep this outside air from leaking *into* the vacuum. To do this, there's an air-tight seal on each jig that's formed by a simple strip of foam, see box on next page.

**FINISH.** But even with the foam, outside air can be drawn right *through* some materials. So it's important to seal the exposed surfaces of the jig with a film finish. Note: The plastic laminate on the top and bottom of the vacuum table seals those surfaces.



◀ **Vacuum Table.** To hold a workpiece securely in place, a vacuum is formed on the surface of this compact table.

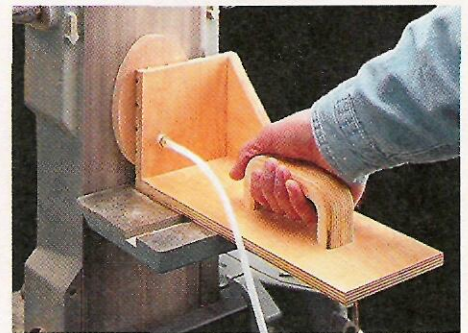

▶ **Small-Piece Sanding Jig.** A vacuum plate in the front of this jig makes it easy to sand small workpieces safely.

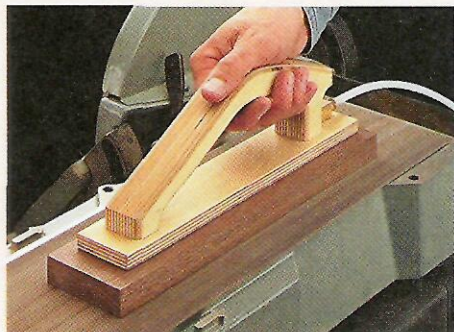

▲ **Push Block.** This push block works together with the vacuum system to provide a firm grip on a workpiece.

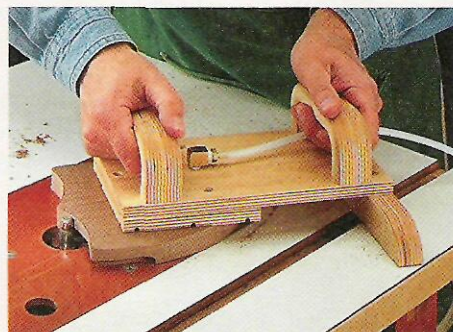

▲ **Routing Jig.** A vacuum allows this jig to hold small parts so you can rout them safely on a router table.

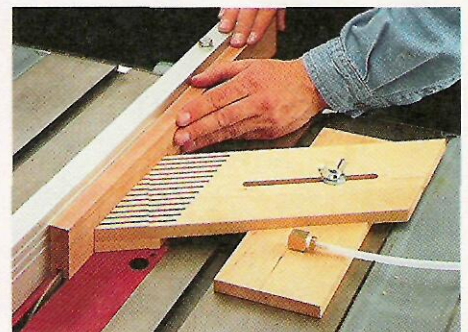

▲ **Featherboard.** All it takes to attach this featherboard to a table saw is to flip a switch on the vacuum system.



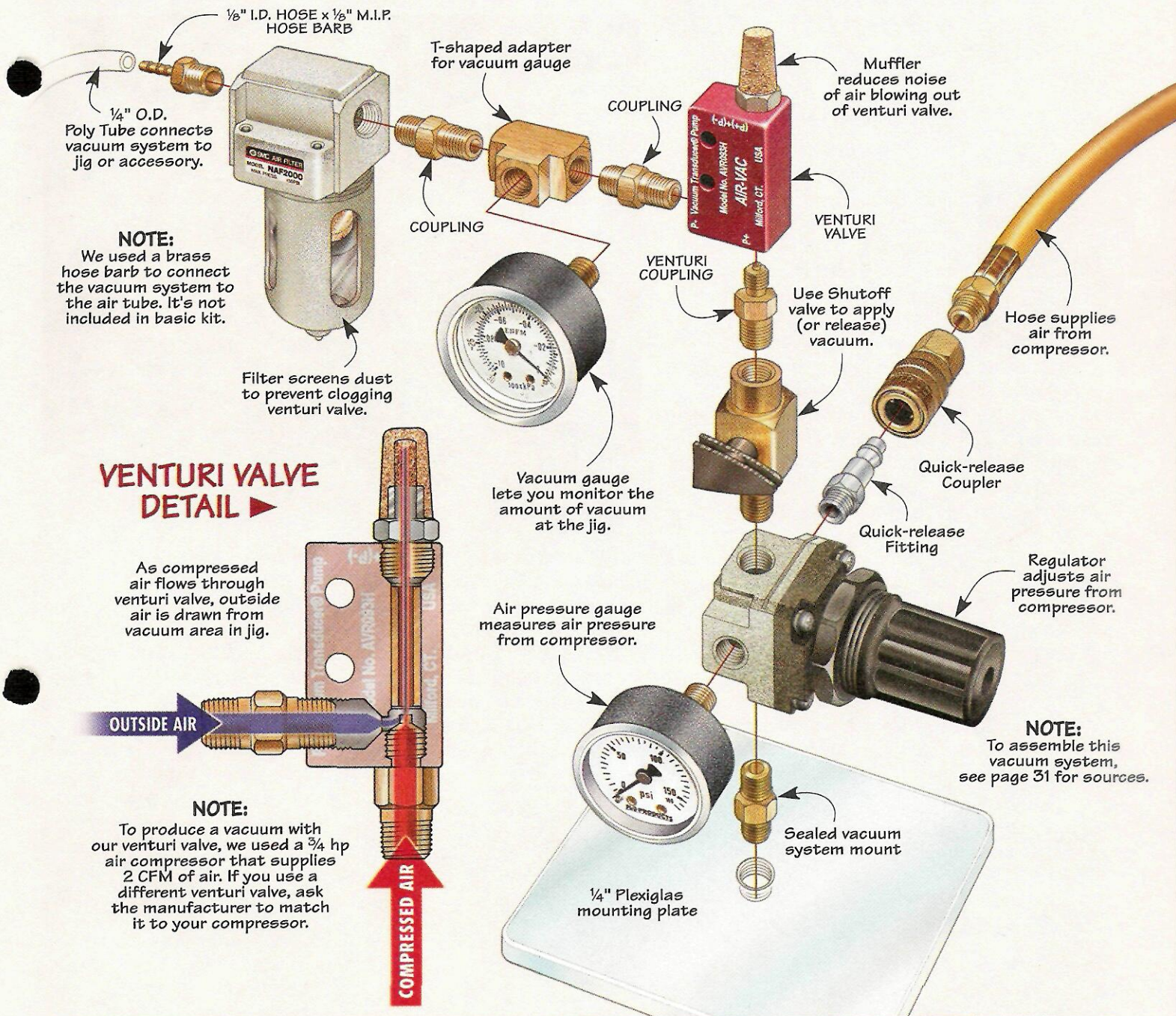

## Foam Backer Rod

It's one thing to establish a vacuum in each of the jigs. But to maintain that vacuum, you have to keep outside air from leaking back in.

**BACKER ROD.** The key to sealing out this air is a 1/4" dia. strip of foam called *backer rod*, see photo at right. Typically, it's used to fill gaps or cracks around doors and windows before they're caulked. But it's the perfect

material for sealing air out of the vacuum as well.

One reason is the foam has just enough "give" to fit snug in the grooves that are routed in each jig. And even though it's compressed when the vacuum is applied, the foam springs right back.

**SOURCES.** Backer rod is available from many building supply companies



that provide materials for contractors. (It costs about a penny a foot.) If you can't find it locally, you can order it from a company called *Construction Materials* by calling (515) 263-9006.

# Vacuum Table

One of the handiest ways to make use of the vacuum clamping system is with this vacuum table, see photo at right. About the size of a chessboard, it holds a workpiece securely in place without any clamps to get in the way.

The basic idea of the vacuum table is simple. A vacuum is formed *under* the workpiece. This way, the air *above* it exerts pressure downward that holds the workpiece tightly against the top of the table.

**VACUUM AREA.** To accommodate workpieces of different sizes, you can make the vacuum area larger or smaller. The key is a gridwork pattern of grooves that accept the foam backer rod.

When working with small pieces, place the foam around the area in the center of the table, see inset above left. Or surround a larger area for big workpieces, see photos at bottom of next page.

Okay, so the table keeps the workpiece from moving around. But what holds the table in place? There's also a vacuum



▲ To produce an air-tight seal, wrap the threads of the brass fitting with Teflon tape before screwing it in place.

established on the *bottom* of the table, see inset above right. It acts like a suction cup to anchor the table on the bench.

**TOP & BOTTOM.** The table starts out as an identical *top* and *bottom* (A) piece made from 3/4"-thick MDF, see Fig. 1. To provide a durable work surface, both pieces are covered with plastic

laminate on one side.

**AIR CHANNEL.** The opposite (interior) side of the top and bottom has a groove that's routed from one end of each piece to the center, see Fig. 1. Along with a hole (drilled later), these grooves form a channel for the air that's drawn from the top and bottom surfaces of the table.

**GLUE UP.** At this point, you're ready to glue the top and bottom together. To prevent air from leaking *between* the two layers, apply a thin layer of glue on both surfaces. Just be careful to avoid getting glue in the grooves — you don't want to clog the air channel.

**DRILL HOLE.** Now you can complete the air channel by drilling a centered hole through the table, see Fig. 2. It connects the top and bottom surfaces which produces a vacuum on each side.

To maintain this vacuum, you need to keep outside air from leaking in. That's where the foam comes in. To create an airtight seal, it fits in the grooves in the top and bottom of the table.

**GROOVES.** One groove runs around the perimeter on *both* sides of the table, see Fig. 2 and Shop Solutions on page 14. And

**EXPLODED VIEW**  
OVERALL DIMENSIONS:  
17"W x 19 1/16"H x 13"D

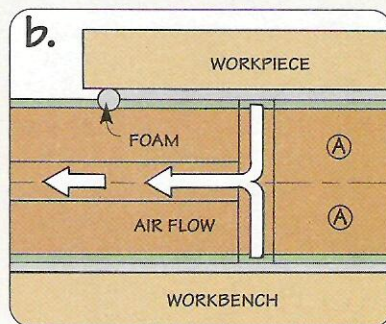
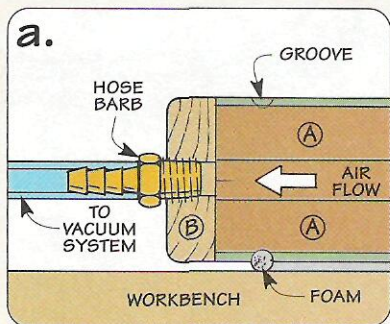
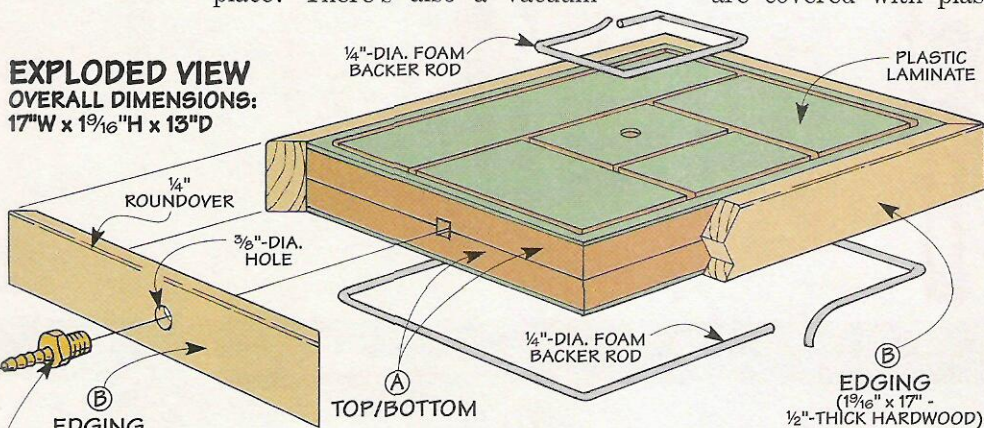

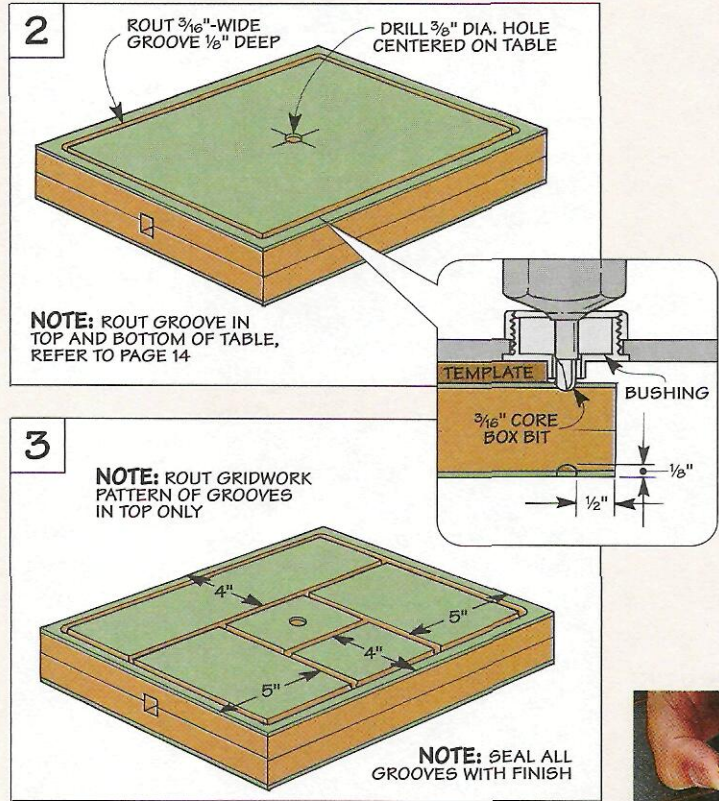
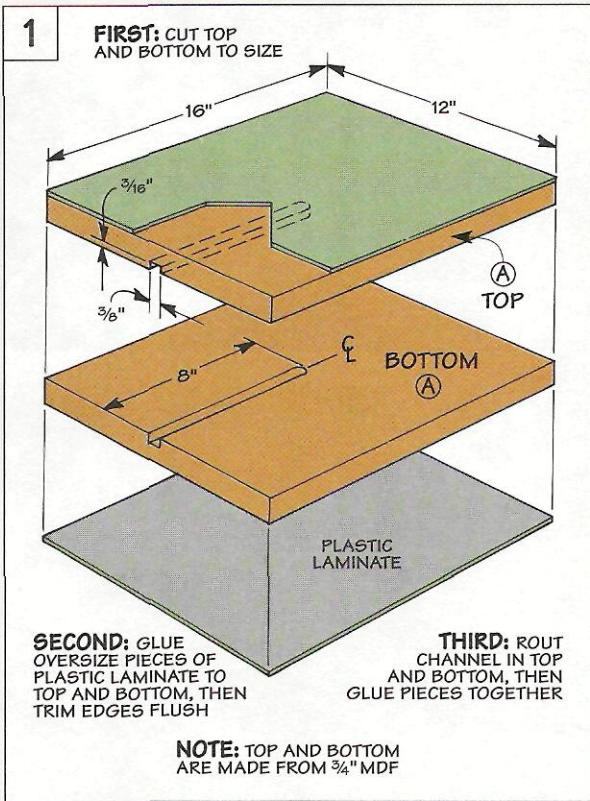

the gridwork pattern of grooves is routed in the top only, see Fig. 3.

Regardless of the location, one thing to be aware of is the *depth* of the grooves. The idea is to rout the grooves so the foam is a bit proud when it's pressed in place. (I routed 1/8"-deep grooves.) When the vacuum is applied, this

prevents the foam from getting crushed all the way down which could allow air to leak in.

The *shape* of the grooves is also important. To seal out air, the grooves are curved on the bottom to match the shape of the foam. I found that a 3/16" core box bit created just the right profile.

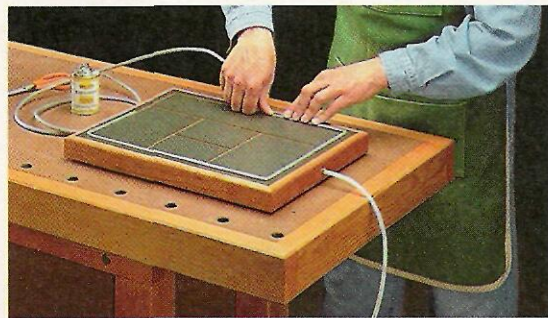

◀ *To increase the size of the vacuum area, all you need to do is surround a larger area of the table with foam.*

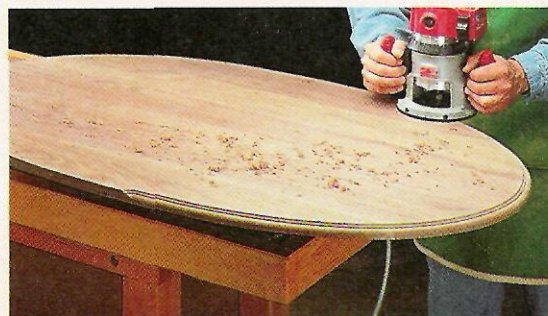

◀ *When the vacuum is applied, even a large workpiece is held securely in place — and there aren't any clamps to get in the way.*

**EDGING.** After routing the grooves, I "wrapped" the exposed edges of the table with hardwood *edging* (B), see Exploded View on page 18. These are just 1/2"-thick strips that are mitered to length.

Before gluing the edging in place, there's one last thing to do. That's to drill a 3/8"-dia. centered hole in the piece of edging that covers the air channel.

**HOSE BARB.** This hole accepts a brass fitting called a *hose barb*. (I picked it up at the local hardware store.) The "barbed" end of this fitting makes it easy to slip the air tube from the vacuum system on and off. After wrapping the threads of the hose barb with tape (see margin on page 18), thread the fitting into the hole.

**INSTALL FOAM.** At this point, the table is almost complete. But before using it, you'll need to install the foam, see margin at right. What works well here is to cut the foam a bit longer (about 1/4") than necessary. This lets you "bunch" the foam at the corners and ends for a better seal.

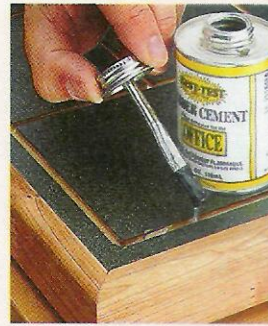

▲ *After brushing rubber cement in the grooves (top), press the foam in place. Bunching the foam in the corners ensures a tight seal (bottom).*

# Small-Piece Jigs

It's hard to clamp a small workpiece when sanding or routing (if you can do it at all). But with the vacuum system and these two small-piece jigs, it's a snap.

## SANDING JIG

The sanding jig is an L-shaped assembly that holds a workpiece tightly against a vertical plate, see top photo. This lets you sand a small workpiece on a disk (or belt) sander without accidentally sanding the tips of your fingers.

**BASE.** To provide a stable platform for the jig, I began by making a plywood *base* (C), see drawing below. (I used 1/2"-thick Baltic birch plywood.)

**VACUUM PLATE.** After cutting the base to size, the next step is to add a *vacuum plate* (D). It's a piece of 1/2" plywood with a waffle pattern of grooves running across it.

Here again, these grooves accept the foam backer rod. You simply arrange the foam around the rule where you want to create the vacuum. Note: The gridwork pattern lets you create a very small vacuum area. But as a rule, the larger the area, the greater the holding power.

As with the vacuum table, the

sanding jig has a barbed fitting that's used to connect it to the air tube from the vacuum system. The fitting threads into a hole centered on one of the squares in the vacuum plate.

**ASSEMBLY.** Now it's just a matter of gluing the vacuum plate to the base. To ensure that it stays perpendicular to the base, I glued a triangular *support* (E) to both pieces.

**HANDLE.** While I was at it, I also added a thick, sturdy *handle* (F). It provides better control (and a comfortable grip) when sanding, see Shop Solutions on page 15.

**ALIGNMENT STRIP.** One final note about the sanding jig. When sanding a number of pieces to shape, you may want to use an *alignment strip* (G) to position each one in exactly the same place on the vacuum plate, see margin.

The alignment strip is a piece of plywood with a rounded "key" on one edge that fits the grooves in the vacuum plate. To make the

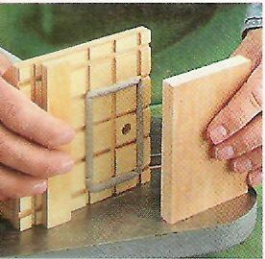
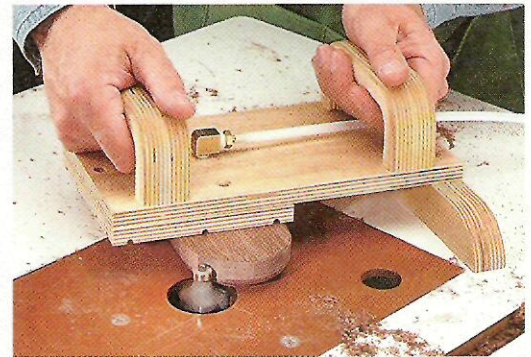
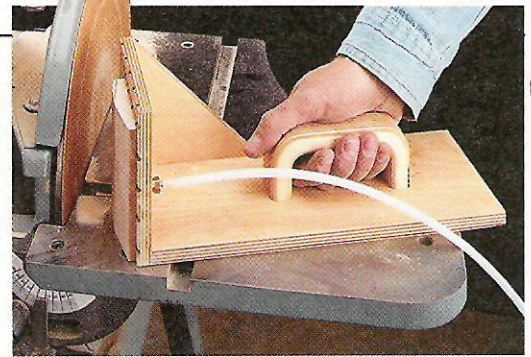

▲ An alignment strip lets you position a workpiece quickly and accurately on the vacuum plate. After applying the vacuum, just set the strip aside.

alignment strip, I started by cutting a wide, shallow rabbet in an oversize piece. Then, after cutting the strip to size, I rounded the key with a sanding block.

## ROUTING JIG

Although the routing jig looks different than the sanding jig, it uses the same basic principle. A vacuum plate holds the workpiece so you can safely rout small pieces on the router table, see

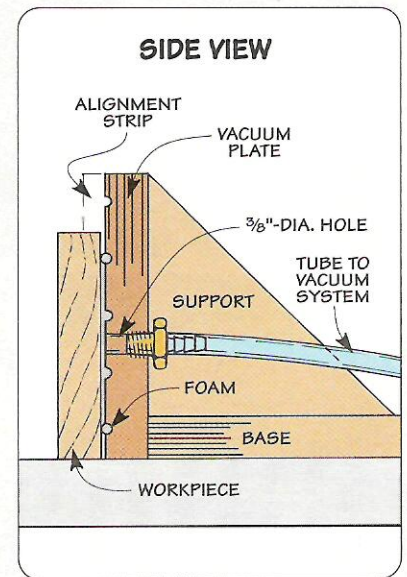
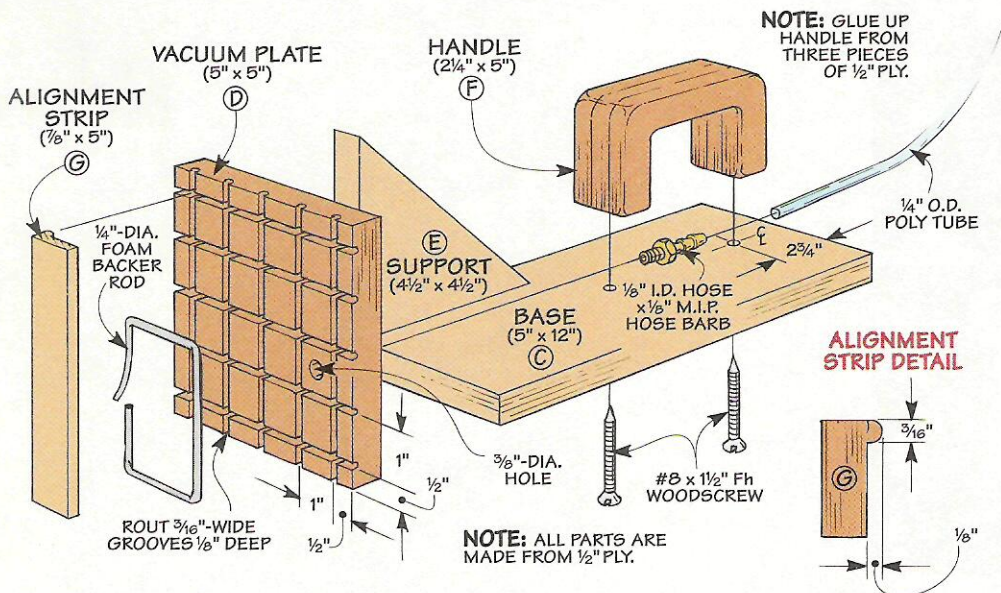

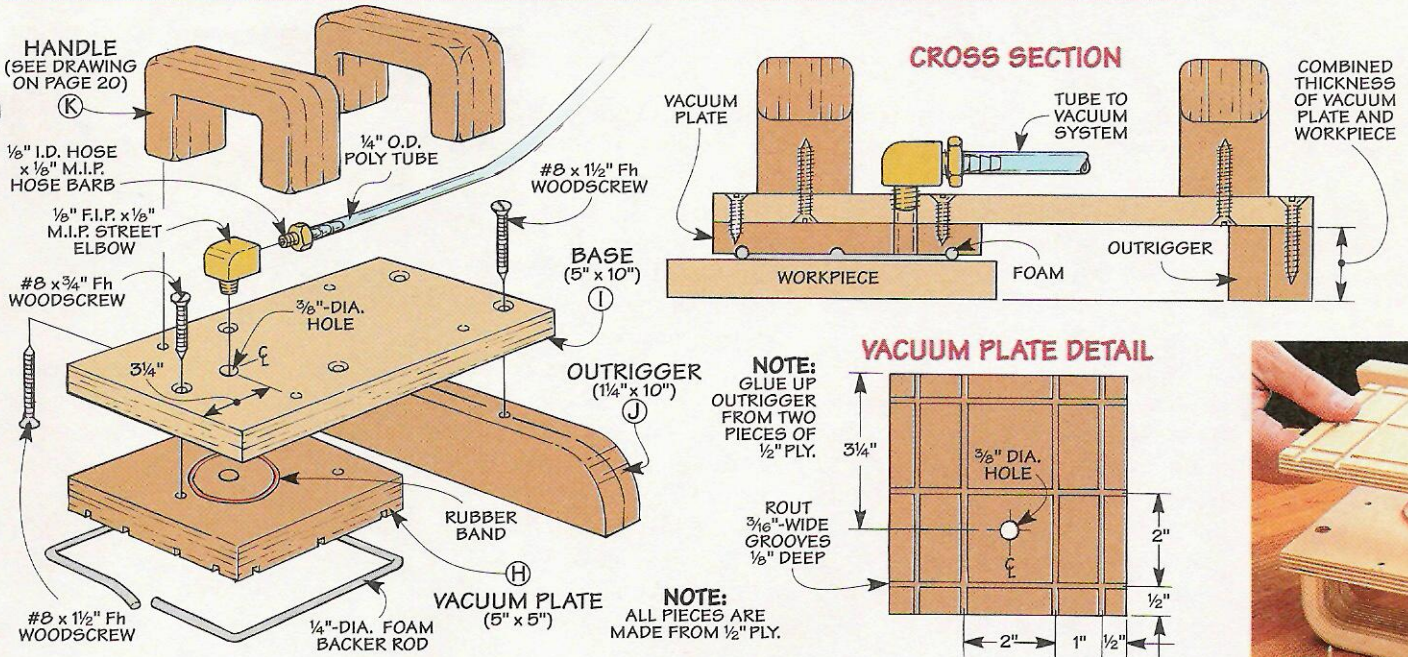

▲ Slipping an ordinary rubber band between the base of the routing jig and the vacuum plate creates an airtight seal.

lower photo on top of page 20. Or if you're making multiple workpieces, you can use the jig for pattern routing, see box below.

**VACUUM PLATE.** Here again, a plywood *vacuum plate* (H) has a series of grooves that let you change the size of the vacuum area, see drawing above. And as before, the vacuum plate is attached to a plywood *base* (I).

But this time, the air that's drawn out of the vacuum area passes through both the vacuum plate *and* the base. This requires drilling a hole in each piece for the air to pass through.

**RUBBER BAND.** One thing to be aware of is that air can leak between the base and the vacuum plate. So to create an airtight seal, I used an ordinary rubber band that's sandwiched between the two pieces, see margin.

**OUTRIGGER.** After screwing the vacuum plate to one end of the base, I attached an *outrigger* (J) to the other end. It prevents the jig from accidentally tipping which could gouge the workpiece.

To provide a stable base, the outrigger is 1" thick. (I glued up two pieces of 1/2" plywood.) But its height (width) depends on the thickness of the workpiece.

The idea is to size the outrigger

so the workpiece lies flat on the router table. To accomplish this, I cut the outrigger to width to match the *combined* thickness of the vacuum plate and the workpiece, see Cross Section above.

**BRASS FITTINGS.** After the outrigger is screwed to the base, you'll need to provide a way to connect the jig to the air tube from the vacuum system.

As with the sanding jig (and

vacuum table) I used a straight hose barb. But this time, it doesn't thread into the hole in the base. To keep the hose from sticking straight up out of the jig (which would be a nuisance), I threaded a street elbow into the base. Then I tightened the hose barb in the street elbow.

**HANDLES.** All that's left is to add two handles. They're identical to the handle on the sanding jig.

## Pattern Routing

If you need to rout a number of pieces to the exact same shape, this small-piece jig is ideal for *pattern routing* as well.

The basic idea here is simple. The vacuum plate on the jig is replaced by a plywood template that has a vacuum area on the *bottom*, see inset.

Once the vacuum is applied, the workpiece is held tightly against the template. By running the template against the bearing on a pattern bit, the workpiece is trimmed to the identical shape as the template, see photo above right.

To create the vacuum area, you'll need to rout a groove in the bottom of



the template for the foam. As with the vacuum plate, there's a hole in the template to draw air out of the vacuum area. But this time, I drilled a large (3/4"-dia.) hole. This makes it easy to align the holes in the template and the base of the jig. Note: Here again, slip a rubber band between the template and the base before screwing them together.

# Push Block

This push block is perfect in situations when an ordinary push block just won't work.

Take a plunge cut on the router table for instance. You have to carefully lower the workpiece onto the spinning bit at the beginning of the cut, then gingerly lift it off at the end. And all the time, the fence prevents you from getting a good grip.

But this push block holds the workpiece like a magnet, see photo. As a result, you have complete control over the cut.

**VACUUM PLATE.** The key is a narrow *vacuum plate* (L) with a vacuum area on the bottom, see

drawing. This vacuum area is formed the same way as the others — just rout a groove around the perimeter of the plate and press in the foam.

Here again, I wanted the tube that connects the push block to the vacuum system to run straight out the back. So I combined two fittings to form a 90° corner.

**HANDLE.** All that's left to complete the push block is to add a *handle* (M). After experimenting with several different handles, I decided on the shape shown in



the pattern below. It provides a comfortable grip. And it has a small “rest” in back for my hand.

Like the other handles, it's made by gluing up three pieces of 1/2" plywood. After band-sawing the handle to shape, I routed an 1/8" roundover on all the edges except where it contacts the vacuum plate.

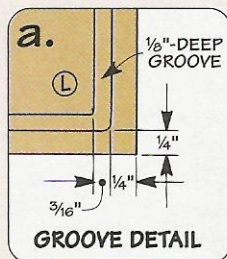

**NOTE:** GLUE UP HANDLE FROM THREE PIECES OF 1/2" PLY.

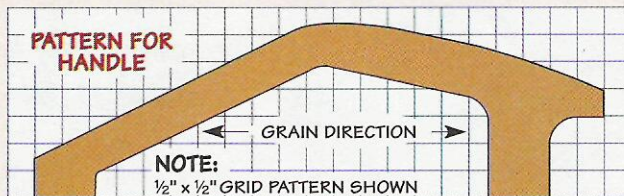
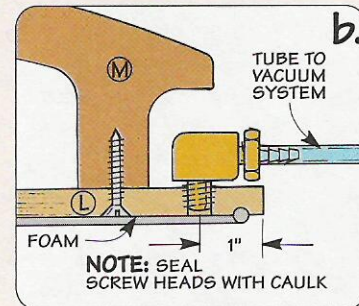
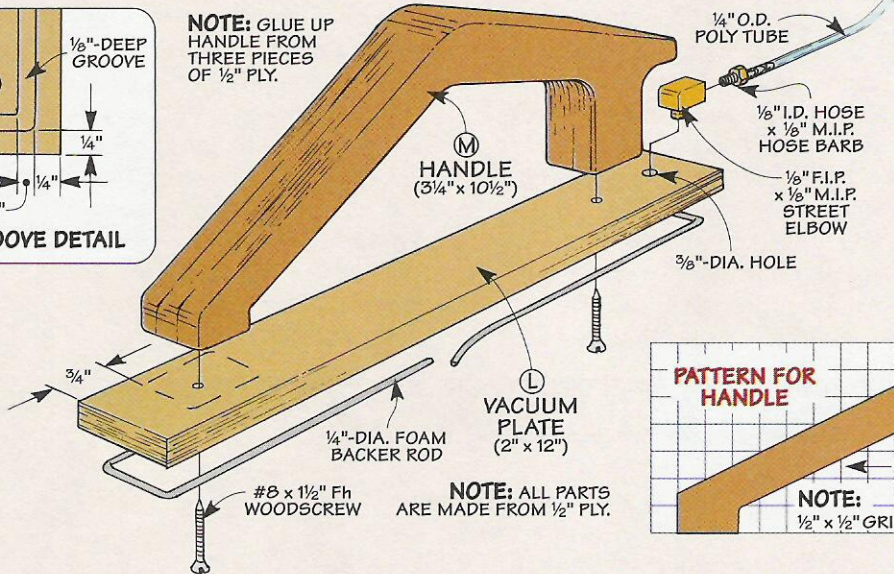

# Featherboard

It's hard to imagine a more practical use of the vacuum system than to hook it up to this featherboard, see photo.

The featherboard attaches quickly and easily to a router table (or table saw) without fiddling with clamps. Yet even though it's held firmly in place, you can adjust it in seconds.

The reason is simple. There's a vacuum area formed in the base of the featherboard, see drawing on page 23. So the base sucks

down tightly against the table like a giant leech. But the featherboard slides back and forth in an angled notch in the base. This lets you adjust the amount of pressure against the workpiece.

**FEATHERBOARD.** The *featherboard* (N) starts out as a 1/2"-thick hardwood blank, see Fig. 4. To make the featherboard adjustable, there's a slot centered on the



blank. I drilled a series of holes to form the slot then filed the remaining waste.

Since the featherboard will rest on the base in use, the “fingers” would be raised above the table.

That's okay for thick stock. But for thin pieces, the fingers would be too high up to apply pressure. The solution is to increase the thickness of the end of the featherboard.

**FILLER BLOCK.** To do this, I added a *filler block* (O), see Fig. 4. It's a piece of 1/2"-thick hardwood attached to the bottom of the featherboard. Before gluing on the filler block, I cut one end at an angle to match the mitered ends of the featherboard that are cut next.

**MITER ENDS.** There's nothing critical about the angle on the ends of the featherboard. I mitered the thick end at a 30° angle and cut the opposite end to match.

**FINGERS.** Now all that's left is to cut a series of saw kerfs to form the fingers of the featherboard. The goal here is to end up with evenly spaced fingers. To do this, I used a simple jig, refer to Shop Solutions on page 15.

**RIP TO WIDTH.** While the jig ensures uniform spacing between the fingers, you may find that the finger formed by the *last*

kerf is wider (or narrower) than the rest. If that's the case, rip a narrow strip off the edge so the last finger on the featherboard matches the size of the others.

**BASE.** Once the featherboard is trimmed to width, you can turn your attention to the *base* (P), see drawing above. The base is a 1/2"-thick piece of hardwood with an angled dado that's cut to match the width of the featherboard.

To establish the vacuum area, the next step is to rout a groove in the bottom of the base for the foam. To lock the featherboard in place, a bolt passes through a counterbored hole in the base and the slot in the featherboard. Tightening a wing nut on the end of the bolt locks the featherboard in place.

**CAULK BOLT.** But locating the hole for the bolt *inside* the vacuum area presents a bit of a problem. When you turn on the vacuum system, it will pull outside air through the hole and into the vacuum area. An easy way to prevent this is to seal the hole before installing the bolt, see margin at right.

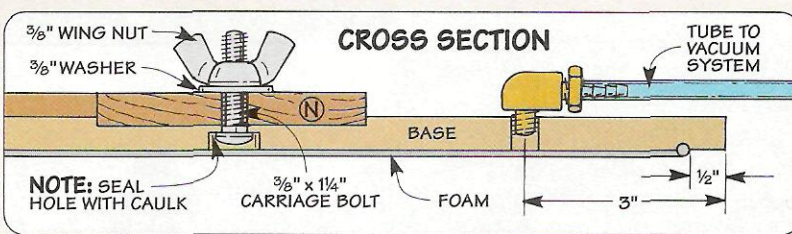
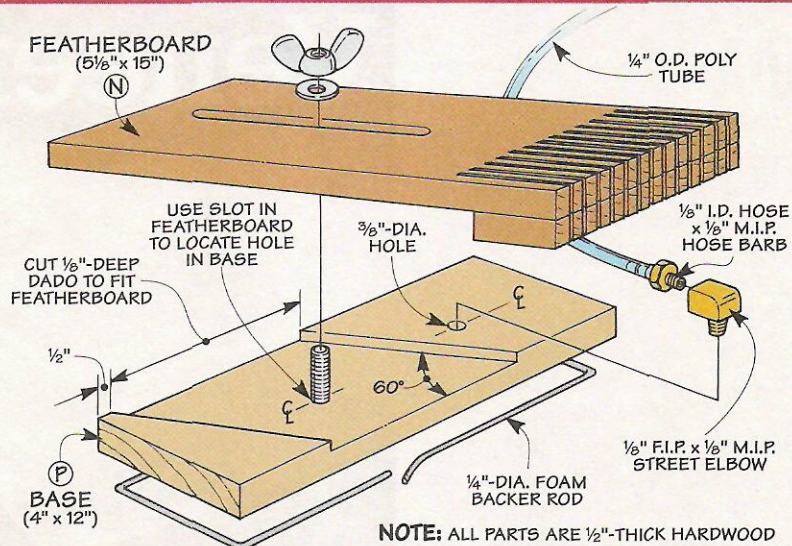

▲ To seal the hole in the base of the featherboard, squeeze caulk in the counterbore before installing the bolt.

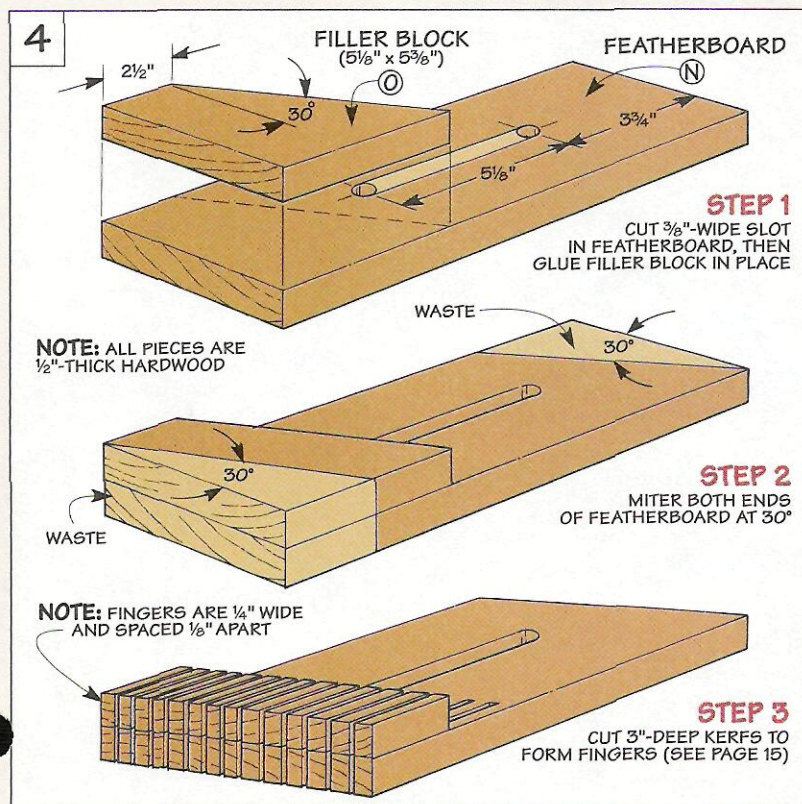

# Vacuum Veneer Press

*A heavy-duty plastic bag and an invisible "clamp" make it easy to apply veneer.*

**W**henever I think of a veneer press, one of the first things that comes to mind is clamps — lots of clamps. But a vacuum veneer press is different.

**PLASTIC BAG.** Basically, it's just a heavy-duty plastic bag. To produce the clamping pressure, the bag is hooked up to a vacuum system. (For information on the system we used, refer to page 16.)

There's nothing mysterious about how a vacuum press works. You just slide the project into the bag and turn on the vacuum system. As the air *inside* gets sucked out, the air *outside* presses down and molds the bag around the project like a shrink-wrapped slab of corned beef.

**EVEN PRESSURE.** But it's not the *amount* of pressure that makes a vacuum press so useful. It's the fact that it distributes this pressure so *evenly*.

For example, when gluing veneer to a large, flat panel, you get perfectly uniform pressure across the *entire* surface, see photo above. So you're not as likely to end up with an air bubble under the veneer.

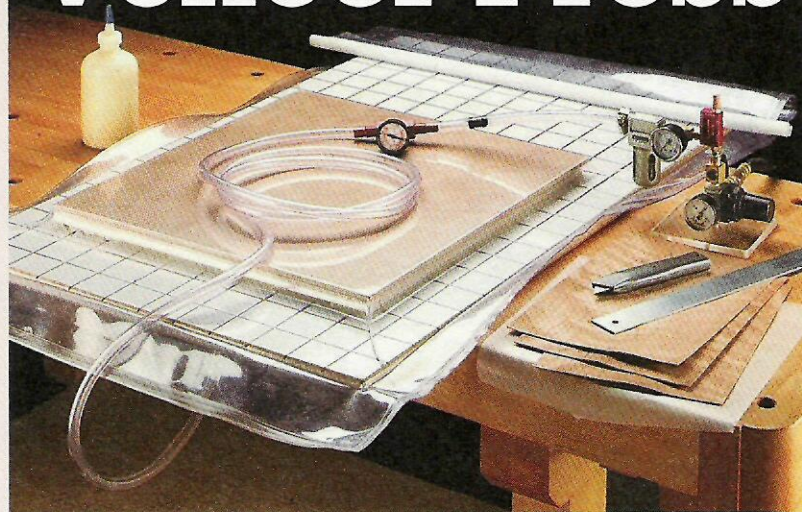

**NO-SLIP.** Another advantage of this even pressure is it prevents the veneer from slipping. Because of this, a vacuum press is also ideal for working with curved shapes, see box on page 25.

## THE BAG

There are a couple of things to keep in mind if you're thinking about getting a vacuum bag.

**SIZE.** First of all, vacuum bags come in a wide range of sizes.

The smallest bags can be used for pieces up to 24" wide and 48" long. But larger bags can handle work that's twice as wide and as long as eight feet. (For sources of vacuum bags, see page 31.)

**THICKNESS.** In addition to size, you also need to decide on the *thickness* of the bag. Most bags are available in 20 or 30 mil thicknesses (.020" or .030").

The 20 mil bags are more pliable. But with repeated use, they're more likely to get small pinholes. The thicker (30 mil) bags are more puncture resistant. And they still have plenty of flexibility.

**COST.** So how much *does* a vacuum bag cost? I bought a 27" x 48" bag (30 mil) for \$68. But I also needed to buy a kit from the manufacturer to hook it up to my vacuum system. (That cost an additional \$68.)

Altogether, that's quite a bit. But if you plan on doing a lot of veneering, a vacuum press is well worth the cost.

## SETTING UP THE PRESS

Once you have the vacuum bag in hand, it's just a matter of setting up the veneer press.

**PLATEN.** To provide a flat, solid surface for the workpiece inside the bag, it rests on a

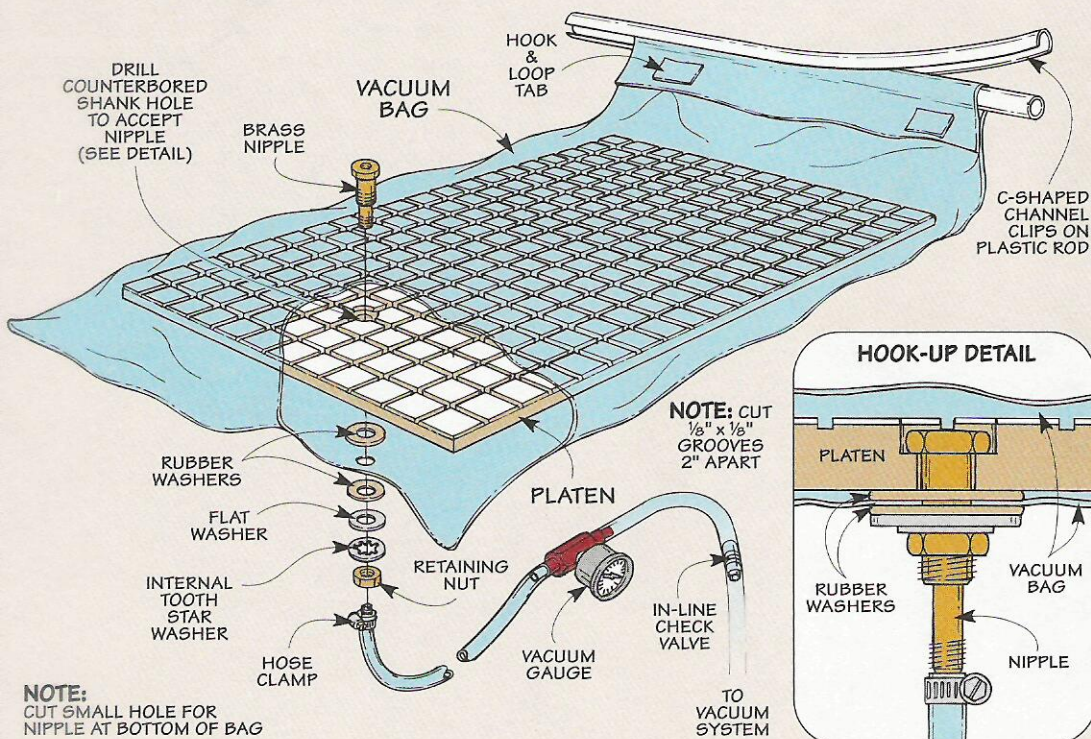



platen made from  $\frac{3}{4}$ "-thick material, see drawing on page 24.

Note: I used melamine because it has a slick surface that prevents glue from sticking to it.

When determining the size of the platen, it's tempting to make it fit tightly inside the bag. But this would stretch the bag as the vacuum is applied. So I cut the platen about 4" narrower and 6" shorter than the bag.

**GRIDWORK.** One thing to note about the platen is there's a grid-work pattern of grooves running across it. These grooves serve as channels for the air as it's drawn out of the bag.

After cutting the grooves it's a good idea to soften the edges and corners of the platen. (I routed a  $\frac{1}{4}$ " roundover on all the edges.) This way, the bag won't have to stretch around any sharp corners as the air is removed.

**NIPPLE.** The air exits the bag through a nipple installed in the platen. It fits in a counterbored shank hole drilled at the intersection of two grooves.

To install the nipple, you'll have to cut a small hole in the bag where it pokes through. This hole

is sealed by two rubber washers that sandwich the bag between them, see detail in drawing. After slipping on a couple of metal washers, tightening a nut secures the nipple to the platen.

At this point, the press is basically complete. But you still need to connect it to your vacuum system. That's where the installation kit comes in.

**KIT.** The kit consists of a vacuum gauge and a short length of plastic tubing. A check valve inside the tubing keeps air from leaking back into the vacuum bag.

### APPLYING THE VENEER

Now you're ready to put the veneer on the core material. The idea is to start by building up a "layer cake" made of four parts.

**GLUE.** To form the bottom two layers, the veneer is simply glued to the core material, see Step 1 above. For most work, I use yellow glue. But if I need more working time, white glue works fine. Shop Tip: A strip of tape will keep the veneer from slipping as you slide it into the bag.

**CAUL.** The top layer is a *caul* made from  $\frac{1}{4}$ " hardboard. The



**1** Start by gluing the veneer to the core material (left). Then cover the veneer with wax paper and a caul made from  $\frac{1}{4}$ " hardboard (right).



**2** After sliding this "layer cake" into the open end of the vacuum bag, seal the bag by clipping the C-shaped channel over the plastic rod.

caul works *with* the bag to distribute pressure across the surface of the veneer. Here again, it's best to soften the edges of the caul. Note: Wax paper prevents any glue that's drawn through the veneer from sticking to the caul.

**LOAD PRESS.** With the caul in place, you just slide the whole thing into the bag like a cake in the oven, see Step 2. It's a good idea to place the project over the nipple. This will keep the vacuum bag from getting sucked down into the opening in the nipple.

**APPLY VACUUM.** All that's left now is to turn on the vacuum system and wait. To provide a good bond, I usually let it "cook" in the bag for about three hours.

When you take it out, the top surface of the veneer may be damp. But don't worry. It's just the moisture from the glue that has been pulled up through the veneer. When the moisture evaporates, the veneer will be glued down nice and tight. 

## Veneering Curved Projects

Applying veneer to a curved surface can be a tricky process. But a vacuum bag simplifies things considerably.

The S-shaped curve on the project shown here is a good example. With the bag hugging the contours of the project, there's a uniform amount of pressure across the top.

**PLATEN SIZE.** One thing to be aware of with curved projects is the size of the platen. It should be small enough so the bag drapes *loosely* around the project during a "dry run." This way, the bag won't stretch (and possibly rip the

seam) as the vacuum is applied.

**COVER OPENINGS.** Also it's a good idea to cover any openings with a scrap. This keeps the bag from getting sucked inside.

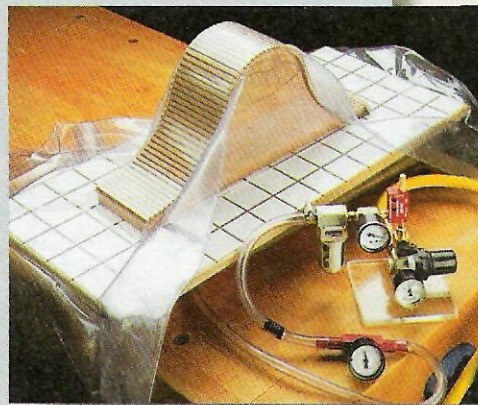

# Roll-Around Support Stand

*This adjustable stand combines rock-solid support with easy mobility.*

Over the years, I've used a number of different support stands (the kind where the workpiece slides on rollers). But they always seem to have a couple of annoying problems — especially when ripping a long board on the table saw.

If the end of the board “sags” as it leaves the saw table, it hits the stand and pushes it back. And if the stand isn't perfectly aligned, I've found that the rollers steer the board *away* from the rip fence.

To solve these problems, I decided to make my own support stand, see photo. Instead of rollers, it has a wide, beveled head that supports the workpiece. This way, it doesn't matter if the end of the workpiece drops down a bit. The bevel acts as a ramp that directs it smoothly to the top of the stand.

**SANDBOX.** And there's no need to worry about the stand creeping back. It's anchored by a large box filled with sand, see photo on next page.

**PORTABLE.** Getting the stand to stay put is one thing. But I didn't want it to become a permanent fixture at my table saw. So to make it easy to roll the stand to my band saw, drill press, or jointer, I

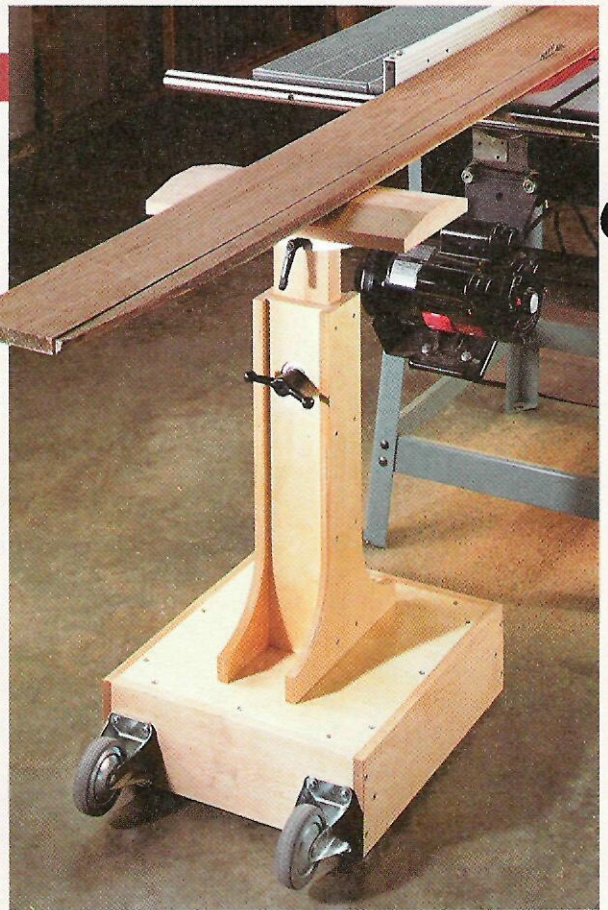

added two heavy-duty casters, see photo A below.

**ADJUSTABLE.** With the stand in place, the head can be adjusted in *two* directions. A telescoping post lets you raise or lower the head to match the height of the tool, see photo B. And if your shop floor is uneven (and whose isn't?) you can tilt the head so it aligns with the surface of the table, see photo C.

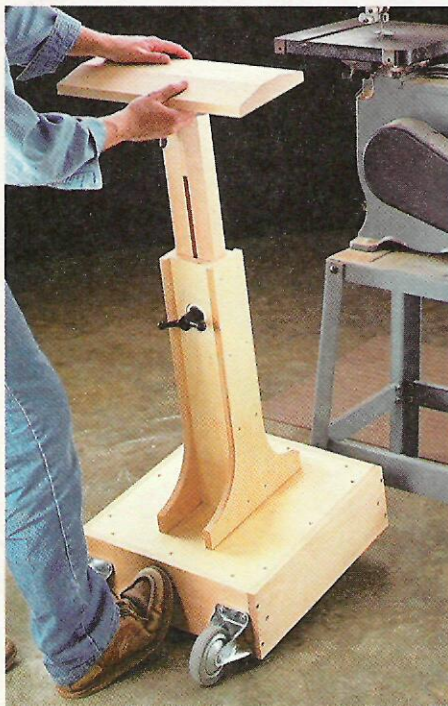

◀ **A. Roll-Around Stand.** It's easy to move the stand from one tool to another. Just tip it back onto a pair of heavy-duty casters and roll it away.

**B. Telescoping Support.** To ▶ match the height of the tool, a telescoping support post lets you adjust the beveled head from 32" to 48" above the floor.

**C. Tilting Head.** If the floor is ▶ uneven, tilt the head of the support so it aligns with the table on the tool. An adjustable handle locks the head in place.



**EXPLODED VIEW**  
**OVERALL DIMENSIONS:**  
 18"W x 48"H x 23"D  
 (FULLY EXTENDED)

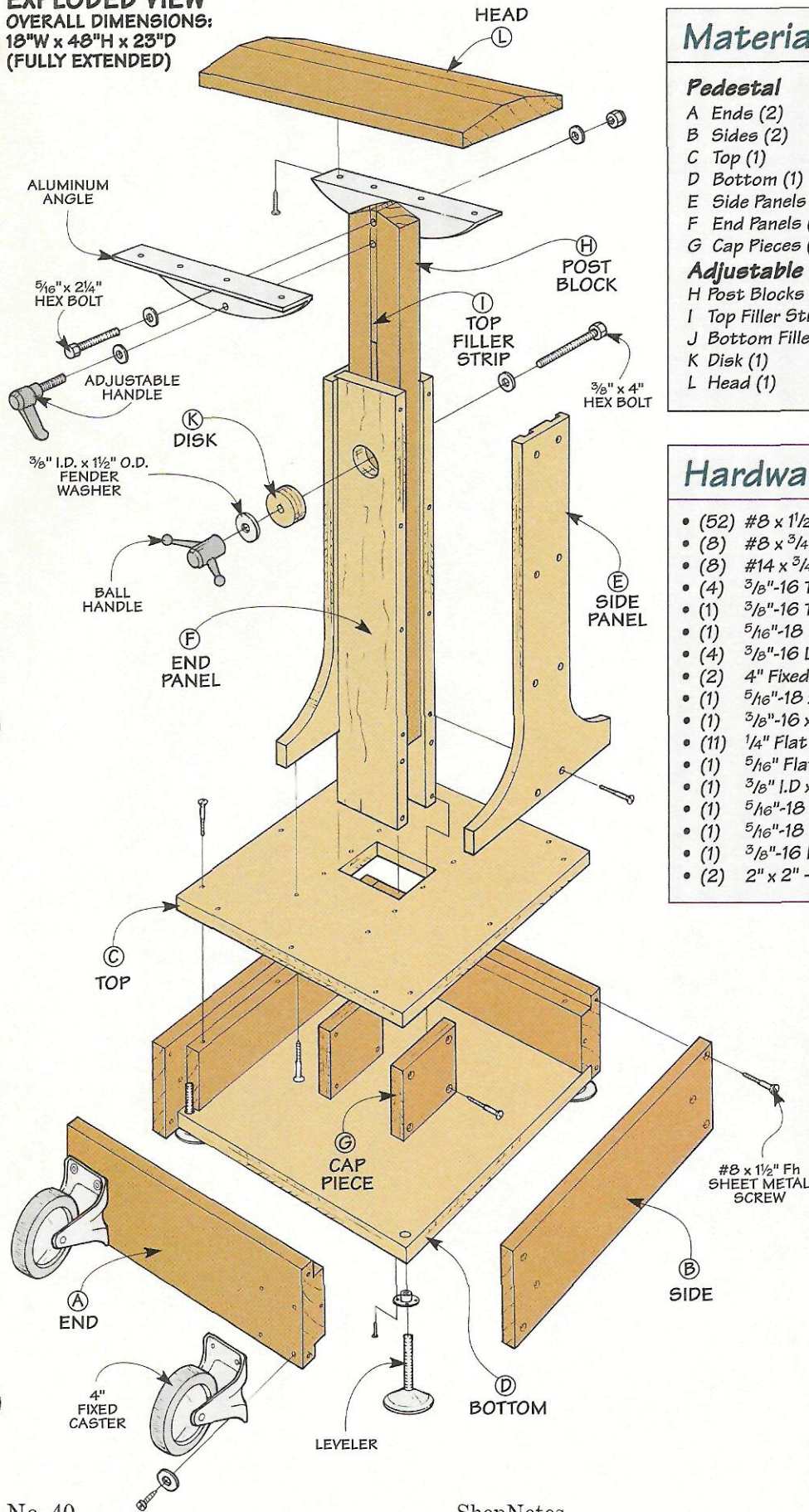

## Materials

### Pedestal

A Ends (2)	1 <sup>3</sup> / <sub>4</sub> x 5 <sup>1</sup> / <sub>2</sub> - 16 <sup>1</sup> / <sub>2</sub>
B Sides (2)	1 <sup>3</sup> / <sub>4</sub> x 5 <sup>1</sup> / <sub>2</sub> - 18
C Top (1)	16 <sup>1</sup> / <sub>2</sub> x 16 <sup>1</sup> / <sub>2</sub> - <sup>3</sup> / <sub>4</sub> Ply.
D Bottom (1)	16 <sup>1</sup> / <sub>2</sub> x 16 <sup>1</sup> / <sub>2</sub> - <sup>3</sup> / <sub>4</sub> Ply.
E Side Panels (2)	12 x 21 <sup>1</sup> / <sub>2</sub> - <sup>3</sup> / <sub>4</sub> Ply.
F End Panels (2)	4 <sup>1</sup> / <sub>2</sub> x 26 <sup>1</sup> / <sub>4</sub> - <sup>3</sup> / <sub>4</sub> Ply.
G Cap Pieces (2)	3 x 4 - <sup>3</sup> / <sub>4</sub> Ply.

### Adjustable Support

H Post Blocks (2)	1 <sup>15</sup> / <sub>32</sub> x 1 <sup>3</sup> / <sub>4</sub> - 29 <sup>1</sup> / <sub>4</sub>
I Top Filler Strip (1)	7 <sup>1</sup> / <sub>16</sub> x 1 <sup>15</sup> / <sub>32</sub> - 7
J Bottom Filler Strip (1)	7 <sup>1</sup> / <sub>16</sub> x 1 <sup>15</sup> / <sub>32</sub> - 5 <sup>1</sup> / <sub>2</sub>
K Disk (1)	4 x 4 (rgh) - <sup>3</sup> / <sub>4</sub> Ply.
L Head (1)	1 <sup>1</sup> / <sub>2</sub> x 8 - 18

## Hardware

- (52) #8 x 1<sup>1</sup>/<sub>2</sub>" Fh Sheet Metal Screws
- (8) #8 x <sup>3</sup>/<sub>4</sub>" Ph Sheet Metal Screws
- (8) #14 x <sup>3</sup>/<sub>4</sub>" Ph Sheet Metal Screws
- (4) <sup>3</sup>/<sub>8</sub>"-16 T-nuts w/ nails
- (1) <sup>3</sup>/<sub>8</sub>"-16 T-nut w/ prongs
- (1) <sup>5</sup>/<sub>16</sub>"-18 T-nut w/ prongs
- (4) <sup>3</sup>/<sub>8</sub>"-16 Leg Levelers
- (2) 4" Fixed Casters
- (1) <sup>5</sup>/<sub>16</sub>"-18 x 2<sup>1</sup>/<sub>4</sub>" Bolt
- (1) <sup>3</sup>/<sub>8</sub>"-16 x 4" Bolt
- (11) 1<sup>1</sup>/<sub>4</sub>" Flat Washers
- (1) <sup>5</sup>/<sub>16</sub>" Flat Washer
- (1) <sup>3</sup>/<sub>8</sub>" I.D x 1<sup>1</sup>/<sub>2</sub>" O.D. Fender Washer
- (1) <sup>5</sup>/<sub>16</sub>"-18 Lock Nut
- (1) <sup>5</sup>/<sub>16</sub>"-18 Adjustable Handle w/ 1<sup>3</sup>/<sub>16</sub>" Stud
- (1) <sup>3</sup>/<sub>8</sub>"-16 Metal Ball Handle
- (2) 2" x 2" - 12" Aluminum Angle (1<sup>1</sup>/<sub>8</sub>"-thick)

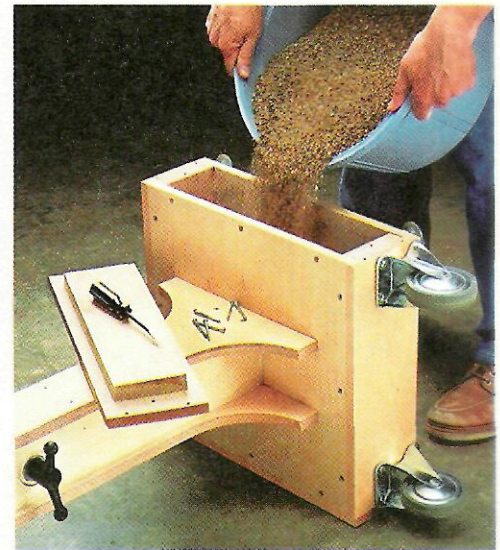

▲ Sand. To provide extra ballast that keeps the support stand from tipping, remove one side of the base and fill it with sand.

# Pedestal

I began work on the support stand by making the pedestal. It consists of two parts: a *base* that anchors the support stand, and a *column* that houses a support post, see drawing.

## BASE

In addition to holding the sand, the base adds rigidity to the column of the support stand.

**BUILD A BOX.** The base is nothing more than a simple box. But because the sand is quite heavy (about 70 pounds), it needs to be sturdy.

So the *ends* (A) and *sides* (B) of the base are made from 1 3/4"-thick hardwood (maple), see Fig. 1. And they're joined together with rabbets and woodscrews.

This requires cutting a rabbet in each end of the sides. There's also a rabbet in the top and bottom edge of each piece. These rabbets accept a plywood top and bottom that are added next.

**TOP/BOTTOM.** The *top* and *bottom* (C) are identical except for one thing — a square opening centered on the top. Later, this opening accepts the end of the column.

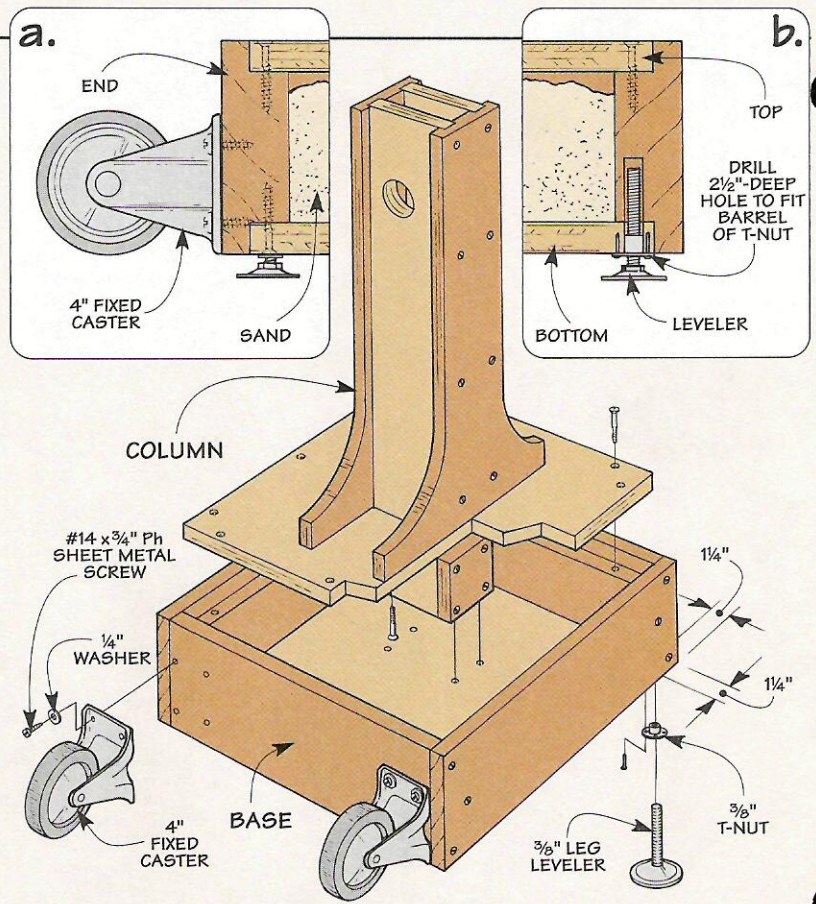
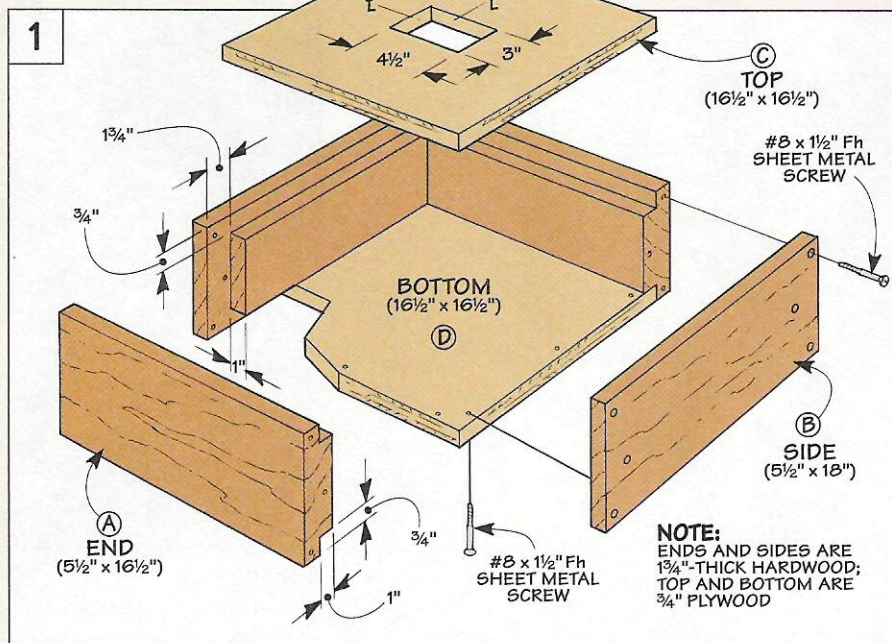

**ASSEMBLY.** To secure the column, you'll need access to the top. So set it aside for now and screw the other pieces together. Note: Don't use glue — you'll need to disassemble the box to add the sand.

**LEVELERS.** With the box complete, I added four levelers. Each leveler threads into a T-nut installed in the corner of the base. This requires drilling a deep hole to accept the barrel of the T-nut and the threaded shank of the leveler, see detail 'b.'

**CASTERS.** All that's left to complete the base is to attach a pair of fixed casters to one end. The casters are screwed in place so the wheels are *above* the floor, see detail 'a'. This prevents the stand from rolling when it's in use. But when you tilt it back, the wheels contact the floor so you can roll it around.

## COLUMN

Now you can turn your attention to the column. Basically, it's a tall, hollow sleeve that allows a support post for the head to slide up and down inside.

To create this sleeve, the column is made up of four plywood panels: a pair of curved

side panels (E) and two rectangular end panels (F), see Fig. 2.

One thing to be aware of here is that the end panels are longer than the side panels. When the column is assembled, this extra length will form a "tenon" that fits into the opening in the top (C) of the base, refer to Fig. 3.

**CUT GROOVES.** The end panels fit into grooves that run the length of the side panels. But don't assemble the pieces of the column just yet.

**FOOT.** First, you'll need to cut the curved "foot" at the bottom of the side panels. It strengthens the column by giving it a wide "stance" — like a lineman on a football team. After cutting the side panels to shape, there's still a little work to be done on the two end panels.

**DRILL HOLES.** To accept a disk that's part of a locking system (added later), there's a large hole drilled in one of the end panels. And a counterbored shank hole in the other end panel accepts a T-nut that's installed now.

**ASSEMBLY.** Now it's just a matter of assembling the column

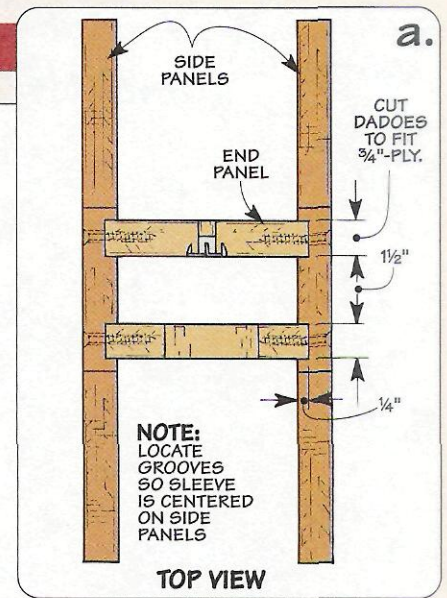
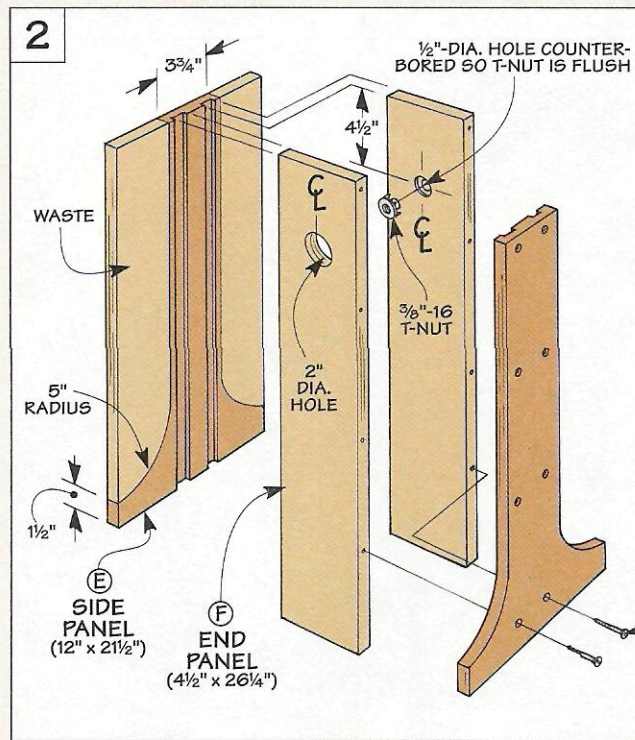

with glue and screws, see Fig. 2a. Just be sure that the top edges of the column are flush.

Once the glue dries, you can attach the column to the top of the base. This is a lot like sticking a fence post into a hole. You simply slide the end of the

column into the opening in the top, see Fig. 3. Then to secure the column, drive screws up into the side panels.

**CAP PIECES.** To prevent sand from "migrating" into the column, I enclosed the openings at the sides with two cap pieces (G), see Fig. 3. These are small pieces of plywood that are screwed to the end panels.

At this point, it's tempting to fill the box with sand. But then you'd have to wiggle the bottom (open) end of the column down into the sand. And here again, sand would get into the column.

**FINAL ASSEMBLY.** An easy way to prevent this is to start by screwing the top (with the column attached) to the base of the support stand. Then to help strengthen the column, drive screws up through the bottom (D) and into the cap pieces.

**ADD SAND.** Once the pedestal is complete, you can add the sand. To do this, remove one side from the base, refer to photo on page 27. Then after caulking the joints between the column and the base, dump in the sand.

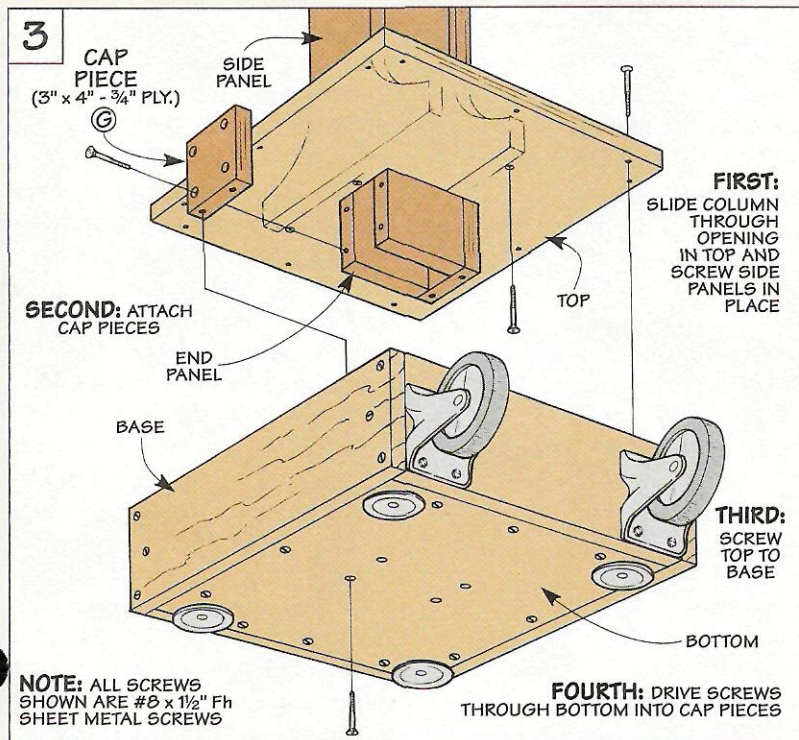

# Adjustable Support

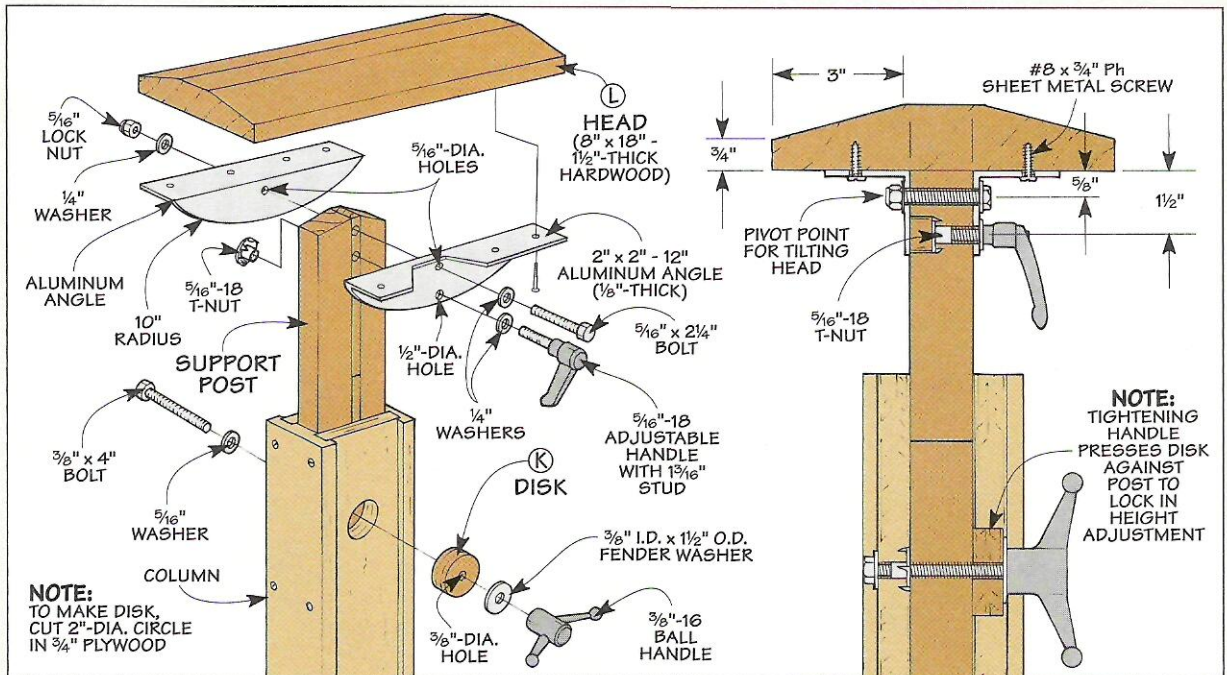

With the pedestal complete, the next step is to add the adjustable support. It consists of two main parts: a sliding *support post*, and a beveled *head*, see drawing.

## POST

To support the head, I began by making a thick post that slides up and down inside the column. A long slot in the post lets you raise or lower the head.

An easy way to create this slot is to glue up four pieces: a pair of *post blocks (H)*, and a *top filler strip (I)* and

*bottom filler strip (J)*, see Fig. 4.

The next step is to drill two holes near the top of the post. The upper hole accepts a bolt (added later). And the hole below it is counterbored for a T-nut.

To provide clearance for the tilting head, you'll also need to bevel the top corners of the post.

## HEAD

All that's left to complete the stand is to add the head that supports the workpiece.

The head is a thick, glued-up

blank with a wide bevel on each side. The bevel "catches" the end of a workpiece so it slides smoothly across the top of the head.

**ALUMINUM ANGLE.** The head is held in place by two pieces of aluminum angle. To avoid having sharp corners hang below the head, I cut a curve on the bottom flange of each piece, see page 14.

You'll also need to drill several holes in the pieces of angle. A  $\frac{5}{16}$ "-dia. hole in *each* piece accepts a bolt that acts as the pivot point for the tilting head. And there's a  $\frac{1}{2}$ "-dia. hole in one piece only for an adjustable handle that threads into the T-nut in the post. Tightening this handle secures the head at the desired angle.

**DISK.** After attaching the aluminum angle with screws, I added a simple plywood *disk (K)* to lock in the height adjustment. It's cut and sanded to fit in the large hole in the front end panel.

The disk fits over a bolt that threads into the T-nut in the back end panel and through the slot in the post. Tightening a metal ball handle onto the end of this bolt presses the disk against the post to lock it in place.

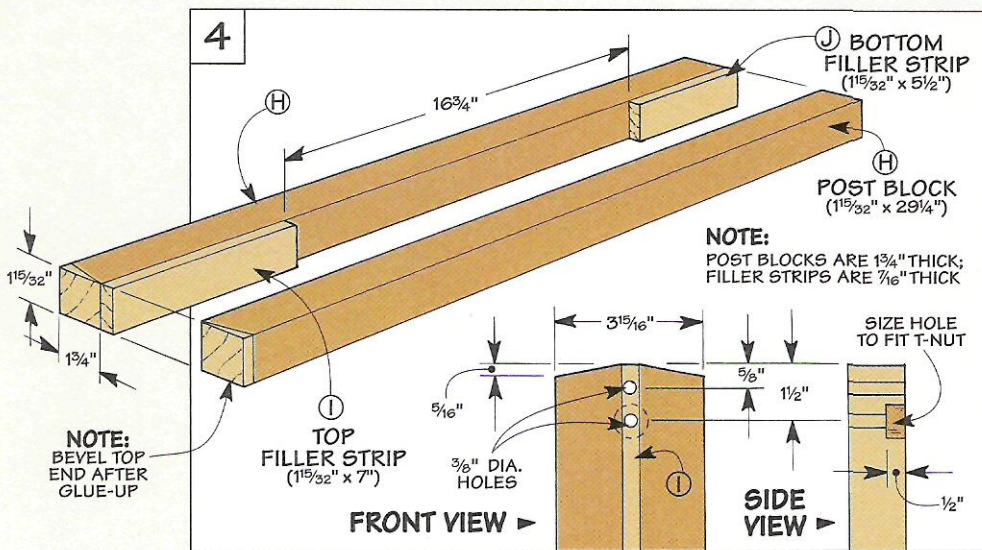

# Sources

## PRODUCT INFORMATION

### ShopNotes Project Supplies

provides sources for the hardware and supplies used to build the projects in this issue.

We've also put together a list of mail-order sources with similar hardware and supplies.



### Vacuum Clamping System ▼

Each of the accessories for the Vacuum Clamping System shown on page 16 depends on one thing to produce a vacuum — a venturi valve that hooks up to an air compressor.

The venturi valve we used is part of a kit that includes everything you need to hook up a vacuum system except the air compressor. The kit comes with or without a regulator. (If you already have a regulator on your air compressor, you don't need another one.) We bought our kit from *Woodhaven*, a woodworking supply company, see margin.

### ◀ Vacuum Bag

A Vacuum Bag (page 24) makes it easy to apply veneer to a curved or flat surface. To make this work, you'll need to hook the bag up to a vacuum system. (For more on this, see page 16.)

Vacuum Bags are available from several mail-order sources, see margin. You'll also need a kit to connect the bag to your vacuum system.



## MAIL ORDER SOURCES

**Woodhaven**  
800-344-6657  
*Vacuum Supplies*

**Quality VAKuum Products**  
800-547-5484  
*Vacuum Supplies, Vacuum Bags*

**Mercury Vacuum Presses**  
800-995-4506  
*Vacuum Supplies, Vacuum Bags*

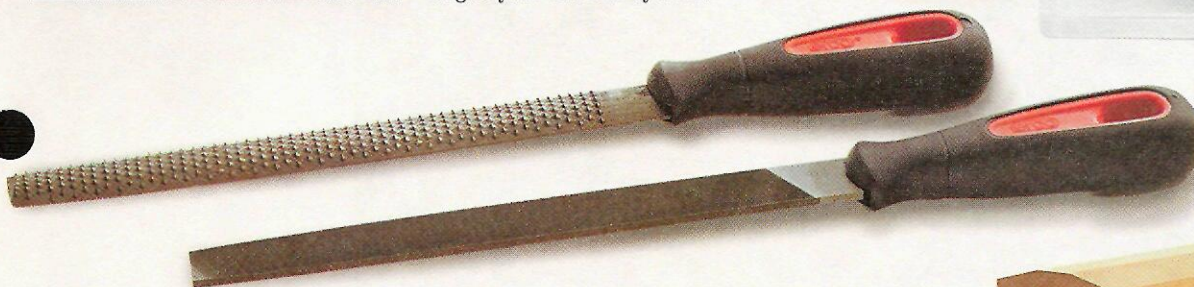

### ▲ Files & Rasps

One useful (but often overlooked) tool is a simple file or rasp. In fact, a basic set of files and rasps will save time and effort in any number of jobs. (For more on this, refer to the article on page 12.)

You can find a good selection of files and rasps at most woodworking stores and in the sources listed in the margin.

### Roll-Around Support Stand ▶

The Roll-Around Support Stand (page 26) is the perfect helper when working with long pieces. To align the support with the tool, you can adjust the height and the angle of the beveled head.

A large, metal ball handle (Part No. TM-1A) locks in the height of the head. And an adjustable handle (Part No. KHA-202) secures the head at the desired angle. Both handles are available from *Reid Tool Supply*, see margin. We've also included sources for the heavy-duty casters.

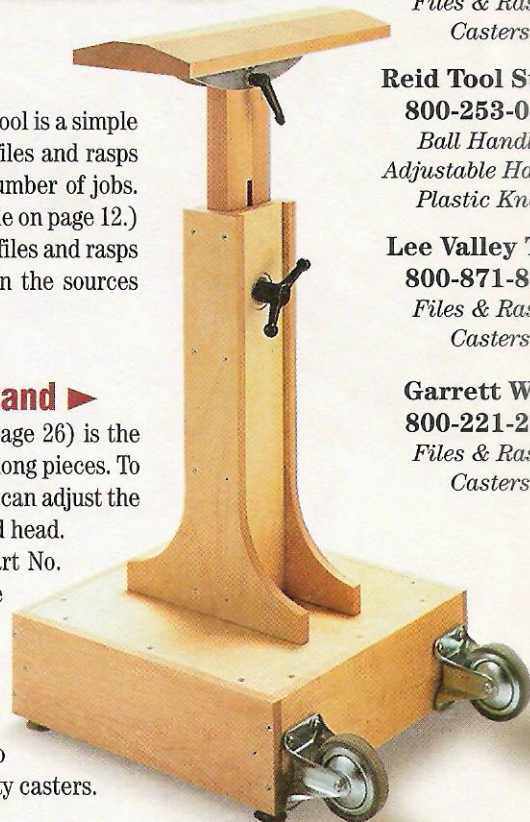

**Woodcraft**  
800-225-1153  
*Files & Rasps, Casters*

**Reid Tool Supply**  
800-253-0421  
*Ball Handles, Adjustable Handles, Plastic Knobs*

**Lee Valley Tools**  
800-871-8158  
*Files & Rasps, Casters*

**Garrett Wade**  
800-221-2942  
*Files & Rasps, Casters*

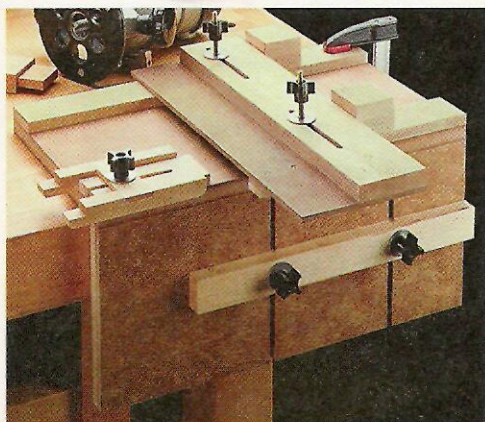

### ▲ Router Tenoning Jig

An easy way to cut tenons quickly and accurately is with a hand-held router and this Tenoning Jig. (For more information on this, see page 6.)

Most of the hardware you need to build this jig is available at local hardware stores. The only exception to this may be the plastic knobs. The knobs we used are available from *Reid Tool Supply*, see margin. (Order Part No. DK-81.)

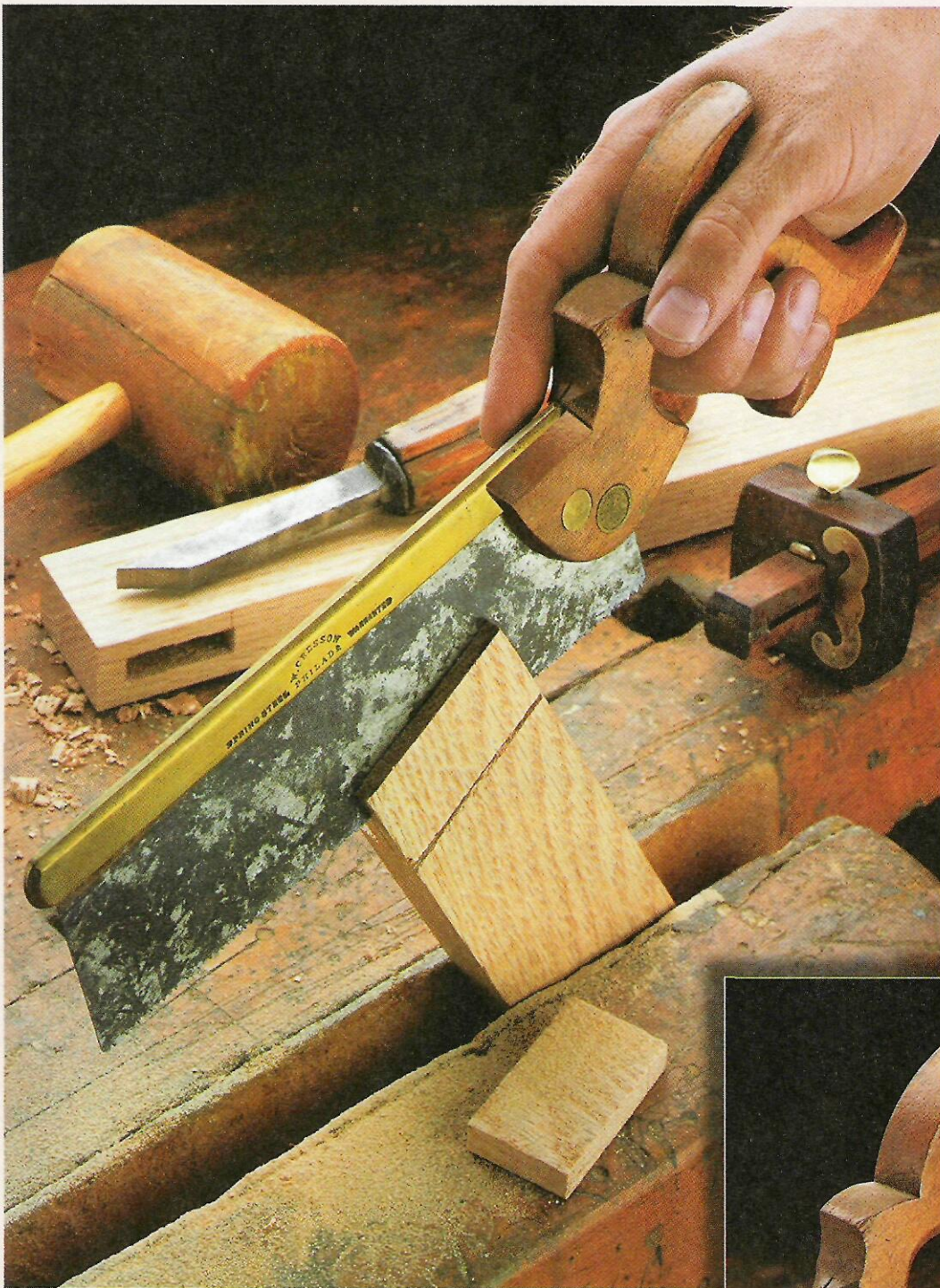

## Scenes from the Shop

Yesterday's craftsmen relied on tools like this old Crisson hand saw to produce accurate cuts. With a brass rib adding rigidity to the blade, it was easy to cut straight, square-shouldered tenons, see photo above. Even the handle is fashioned to provide a controlled cut and a comfortable grip, see inset. (Saw provided courtesy of The Fine Tool Journal at 800-248-8114.)

