

TIPS • TOOLS • TECHNIQUES

# ShopNotes®

Vol. 7

Issue 41

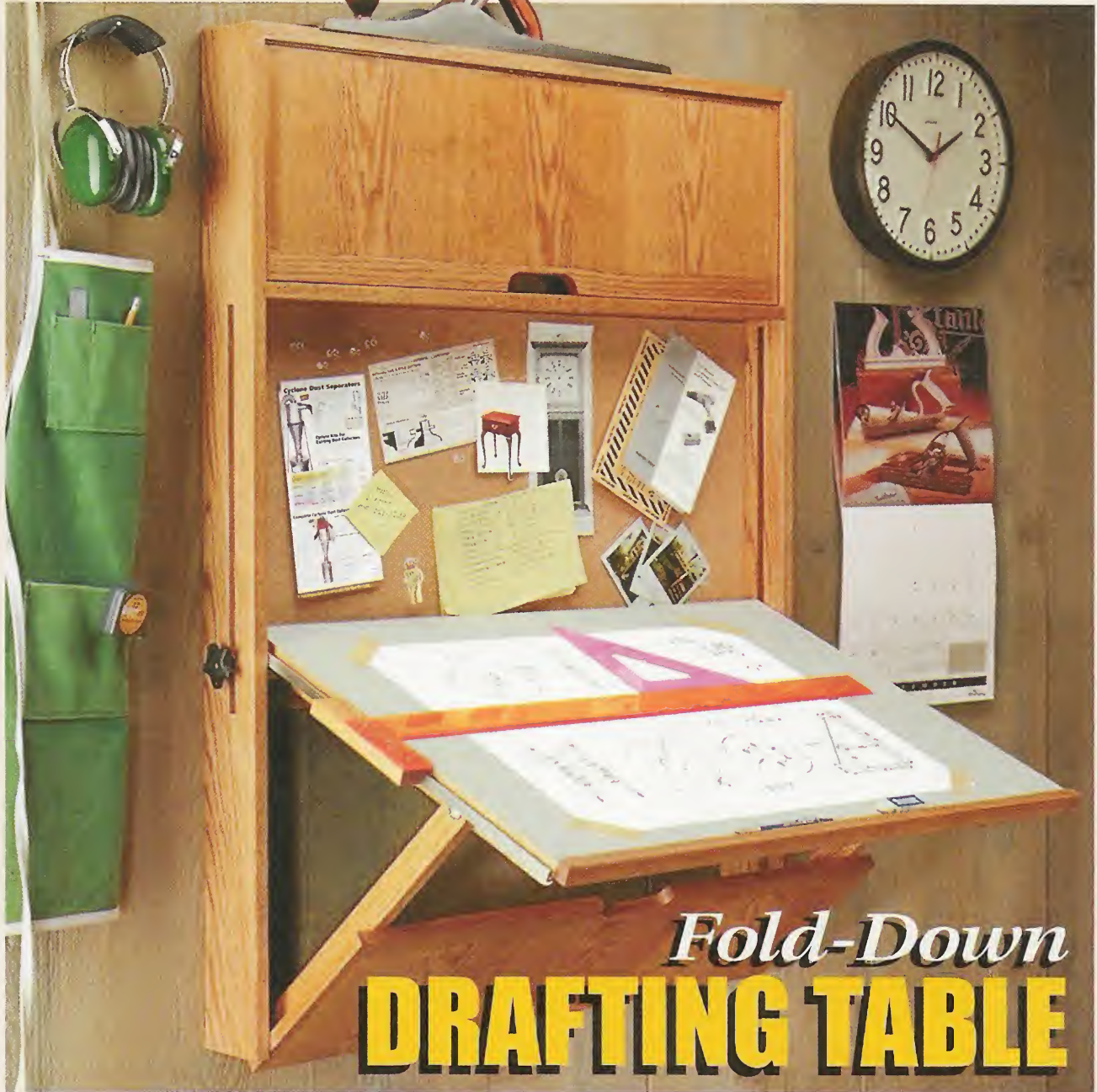

## *Fold-Down* **DRAFTING TABLE**

- Portable Hose Reel ■ Shop-Made Scratch Stock
- Drafting Tools: A Basic Set ■ Bird's-Eye Maple



# ShopNotes®

Issue 41 September 1998

**PUBLISHER** Donald B. Peschke  
**EDITOR** Tim Robertson  
**ASSOCIATE EDITOR** Tom Bagnol  
**ASSISTANT EDITOR** Bryan Nelson  
**ART DIRECTOR** Cary Christensen  
**SR. GRAPHIC DESIGNER** Kurt Schultz  
**SENIOR ILLUSTRATORS** Roger Reiland  
 Mark Higdon

## CREATIVE RESOURCES

*Creative Director:* Ted Kralicek • *Project Developer:* Ken Munkel • *Senior Project Designer:* Kevin Boyle • *Project Coordinator:* Kent Welsh • *Shop Manager:* Steve Curtis • *Shop Craftsman:* Steve Johnson • *Senior Photographer:* Crayola England

## BOOKS

*Executive Editor:* Douglas L. Hicks • *Senior Graphic Designer:* Chris Glowacki

## CIRCULATION

*Sub. Serv. Dir.:* Sandy Baum • *New Bus. Dir.:* Glenda Battles • *Renewal Mgr.:* Paige Rogers • *Billing Mgr.:* Rebecca Cunningham • *Prom. Mgr.:* Rick Junkins • *New Bus. Mgr.:* Todd L. Bierle • *Asst. Sub. Mgr.:* Joy Krause • *Assoc. Graphic Design Dir.:* Susie Rider • *Sr. Graphic Designer:* Cheryl L. Simpson

## CORPORATE SERVICES

*V.P. of Planning & Finance:* Jon Macarthy • *Controller:* Robin Hutchinson • *Sr. Acct.:* Laura Thomas • *Accts. Payable:* Mary Schultz • *Accts. Rec.:* Margo Petrus • *Prod. Dir.:* George Chmielarz • *Elect. Pub.:* Douglas M. Lidster • *Prod. Asst.:* Susan Rueva • *Pre-Press Image Spec.:* Troy Clark, Minnette Bieghler • *New Media Mgr.:* Gordon C. Galpe • *Multimedia Art Dir.:* Eugene Pedersen • *Network Admin.:* Chris Harrison • *H. R. Asst.:* Kirsten Koele • *Admin. Asst.:* Julia Fish • *Recept.:* Jeanne Johnson, Sheryl Ribbey • *Bldg. Maint.:* Ken Griffith • *Special Proj. Dir.:* Saville H. Inman

## MAIL ORDER

*Operations Dir.:* Bob Baker • *Mat'l Mgr.:* Mark Mattiussi • *Cust. Service Mgr.:* Jennie Enos • *Warehouse Supr.:* Nancy Johnson • *Buyer:* Linda Jones • *Op. Asst.:* Tammy Aldini  
*Tech. Rep.:* Matthew TeRonde • *Cust. Serv. Reps.:* Anna Cox, Tammy Truckenbrod, Adam Best, Nancy Downey, Deborah Rich • *Warehouse:* Sylvia Carey • *Quality Control Technician:* Frank Johnson

ShopNotes® (ISSN 1062-9696) is published bimonthly (Jan., March, May, July, Sept., Nov.) by August Home Publishing, 2200 Grand, Des Moines, IA 50312.  
 ShopNotes® is a registered trademark of August Home Publishing ©Copyright 1998 by August Home Publishing. All rights reserved.  
**Subscriptions:** Single copy: \$4.99. One year subscription (6 issues), \$21.94. Canada/Foreign add \$6 per year.  
**Periodicals Postage Paid** at Des Moines, IA and at additional mailing offices.  
**Postmaster:** Send change of address to ShopNotes, P.O. Box 37103, Boone, IA 50037-2103.  
**Subscription Questions?** Write to: ShopNotes Customer Service, P.O. Box 842, Des Moines, IA 50304-9961. Or call 1-800-333-5854, 8:00 am to 5:00 pm, Central Time, weekdays. FAX 515-283-0447  
**E-Mail:** ShopNotes@shopnotes.com  
**Internet:** http://www.shopnotes.com  
**PRINTED IN U.S.A.**  
 Reprinted 2002

## WoodNet™

### NOW ON THE WEB!

- 101 Woodworking Tips Online
- Woodworking Techniques — Step-by-Step
- Project plans you can download
- WoodNet Forum — Woodworkers' Q & A
- Power Tool Reviews

Point your browser to: <http://www.augusthome.com>  
 Select "Woodworking" from the Welcome Page menu.

## EDITOR'S NOTE

# Cutoffs

Whenever I have an idea for a project, I like to get it down on paper right away. Even if it means sketching out a rough drawing on a napkin or the back of an envelope.

Now there's nothing fancy about these drawings. (And the coffee stains don't help much either.)

But they still serve a purpose. For example, the quick sketch on the napkin shown here gave me a good feel for the overall proportions of a project featured in this issue — a fold-down drafting table.

**NAPKIN PLANS.** While these bits and scraps of paper provide a good starting point, they've also managed to get me in trouble. Like the time I built a table using some hastily sketched "plans" on a napkin.

In theory, it sounded simple. I'd jotted down all the important dimensions. And as for the joinery details, I planned to work those out when I came across them.

Not surprisingly, problems began to crop up right away. I cut several pieces too short. And the joinery proved to be a bit more involved than I'd expected.

As it turned out, it wasn't fussing around trying to get things to fit that bothered me. Or even the time and lumber that was wasted in making the pieces over again.

The worst thing was the sinking feeling I got when I finally assembled the table. Instead of the nicely proportioned project that I'd drawn on the napkin, the table was top-

heavy, and the legs looked spindly and out of place.

Although that table isn't around any more, the lesson it taught me *has* managed to stick. Not that I've quit doodling on napkins. But now I don't even get near the lumber pile without a complete set of accurate, detailed drawings.

**DRAFTING TABLE.** Making those drawings is what got me thinking about building a drafting table in the first place. Wouldn't it be nice to have a table that's big enough to spread out a large sheet

of drafting paper so I could make drawings in the shop?

There's only one problem. A table that's large enough to do that would just be in the way most of the time.

The solution was a wall-hung drafting table that *folds down* to create a large drawing surface. Once the drawing is complete, you just fold the table back up. (In the closed position, it only sticks out 4" from the wall.)

Besides the fact it saves space, this table has a couple of other features that are worth a closer look. A metal rail along one edge guides a shop-made T-square. And there's a compartment up above to hold drafting tools and supplies.

But as much as I like all that, the drafting table just wouldn't be complete without one more thing — a bulletin board. After all, how else would I tack up napkins when I sit down to make a drawing?

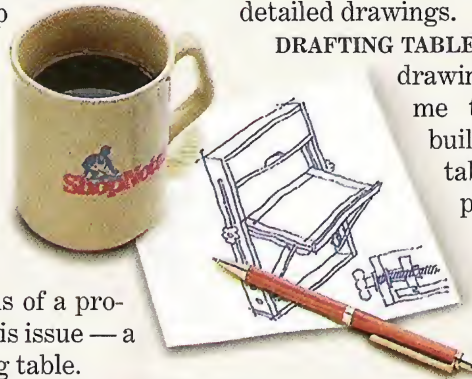

Tim

# Contents

## Features

### Portable Hose Reel \_\_\_\_\_ 6

Build this shop-made hose reel and you'll never waste time untangling the hose on your air compressor. Just give the hose a pull, then wind it up when you're done.

*Hose Reel* page 6

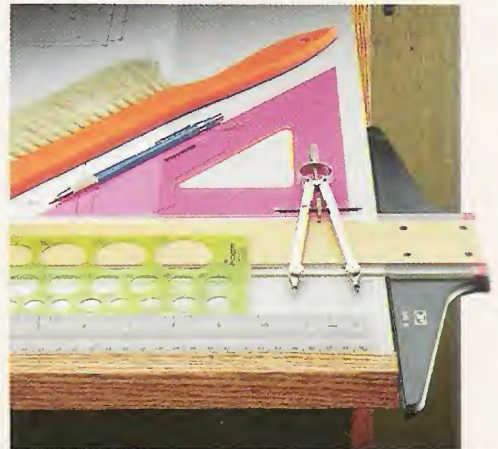

### Drafting Tools \_\_\_\_\_ 12

Whether you're making a detailed drawing or a simple cutting diagram, it pays to have a basic set of drafting tools. Here's a look at the tools we recommend.

*Drafting Tools* page 12

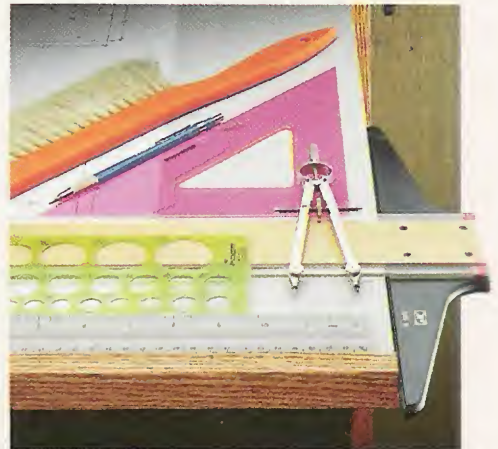

### Fold-Down Drafting Table \_\_\_\_\_ 16

This wall-hung drafting table folds down to provide a large drawing surface. With its built-in T-square and a compartment to hold your drafting tools, it has everything you need to make detailed shop drawings.

*Drafting Table* page 16



### Scratch Stock \_\_\_\_\_ 24

Looking for a way to add a subtle detail that will set your next project apart? Try cutting a decorative profile with this scratch stock. With a metal cutter filed to the desired profile, just pull the scratch stock across the workpiece.

*Scratch Stock* page 24



### Bird's-Eye Maple \_\_\_\_\_ 30

It's a mystery how the tiny "eyes" in bird's-eye maple are formed. But they're certain to attract a lot of attention. We offer tips on working with this highly-figured wood.

## Departments

### Readers' Tips \_\_\_\_\_ 4

Shop-tested tips from our readers to solve their most common woodworking problems. Plus two quick tips.

### Shop Solutions \_\_\_\_\_ 14

Here's a selection of tips from the guys in our shop that will make it easy to build the projects in this issue.

### Sources \_\_\_\_\_ 31

Hardware, supplies, and mail-order sources for the projects featured in this issue.

*Scratch Stock* page 24

# Readers' Tips

## Easy-to-Build Sawhorse



■ To build a sawhorse that provides sturdy support, I angle the legs in *two* directions. They splay out from side to side, and they tilt forward from each end of the sawhorse.

The only problem is this requires cutting compound angles which can be time consuming to set up. So instead, I use a wood wedge to angle each leg in both directions, see photo above.

These *wedges* are bandsawed

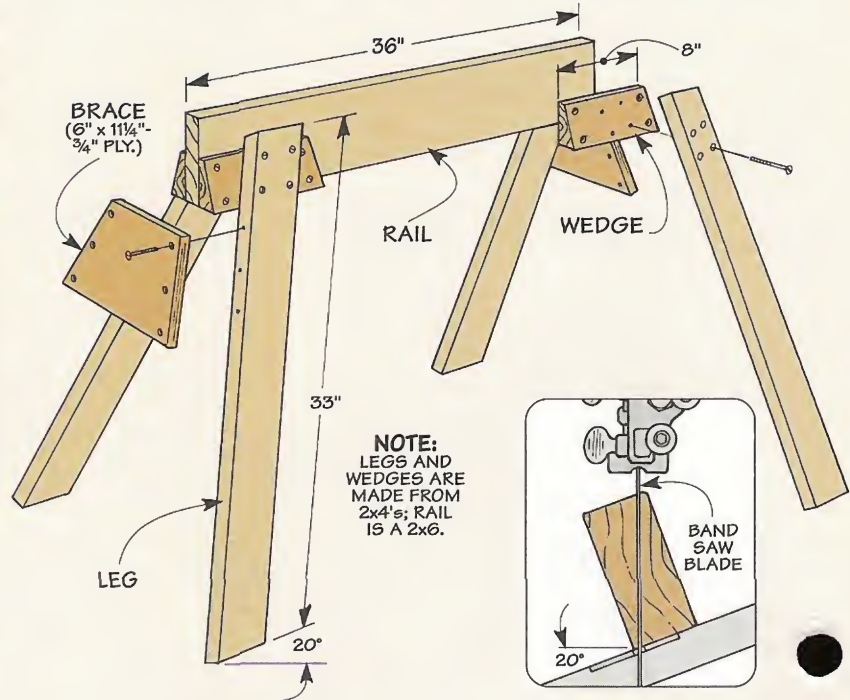

from a scrap 2x4, see detail above. Then they're glued and screwed to the *rail*, see drawing.

The next step is to miter the *legs* to length and attach them to the wedges. The idea here is to position each leg so it's flat against

the wedge *and* rotated forward. (This creates the compound angle.)

After screwing the legs in place, I also added a plywood *brace* for extra rigidity.

*Adolph Peschke*  
Des Moines, Iowa

## Lacquer Thinner Collector

■ I use a spray gun to apply a lacquer finish to many of my projects. When I'm done, I clean the gun using the method suggested by the manufacturer. That requires emptying the canister, pouring in lacquer thinner, and spraying it through the gun.

But I don't like the idea of spraying lacquer thinner into the air. So I use a simple collector that lets me recycle most of the thinner, see drawing.

Basically, the collector is just an empty bleach bottle with an

opening cut in the side. The opening is covered with a plastic scouring pad that's attached with hot glue. (You'll find the pads at any grocery store, see margin.)

Now I just spray the thinner into the bottle instead of my backyard. The pad filters out the lacquer thinner while allowing the clean air to escape. And after the excess lacquer settles to the bottom, I pour off the thinner and reuse it.

*Thomas K. Haltmeyer*  
Peoria, Arizona

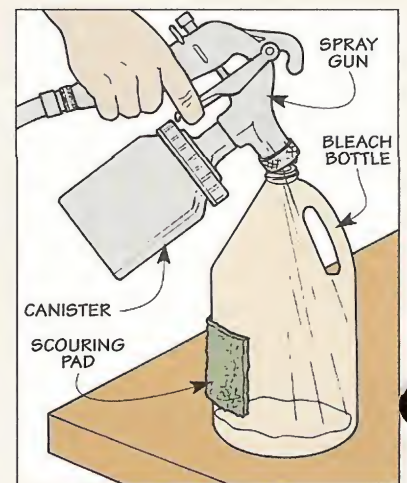

An ordinary plastic scouring pad filters the lacquer thinner.

## Quick Tips



■ If you don't protect your hands when staining, they'll end up the same color as the project.

Although plastic gloves keep your hands clean, they don't come free. But my "gloves" don't cost a penny. I just slip my hand into the plastic bag that the newspaper came in, see photo.

*Stanley Rulapaugh  
Phoenix, Arizona*

■ This hand countersink is ideal if you're working with metal — or if you only have a few holes to countersink in wood.

The countersink bit is attached to a dowel that's shaped to provide a comfortable grip. To secure the bit, the shank is epoxied in a hole in the end of the dowel.

*Robert Adams  
Newark, New Jersey*

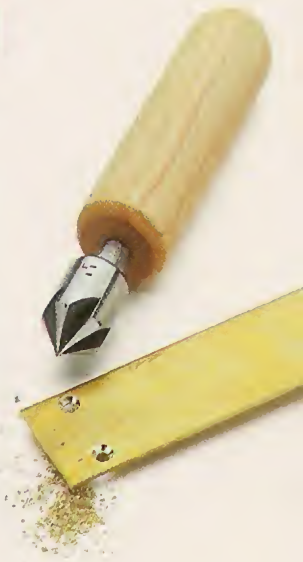

## Shop-Made Clamp

■ When assembling a large cabinet recently, I ran short of pipe clamps. But rather than buy more clamps, I made my own.

What's unusual about these clamps is how the pressure is applied. Instead of tightening a threaded screw, a simple wood wedge is tapped between the clamp and the project.

The clamps are easy to make. Each one consists of a long, wood rail with two clamp heads, see drawing. Note: Just cut the rail to whatever length you need.

A *fixed clamp head* is screwed to one end of the rail. And to accommodate different size projects, an *adjustable clamp head* is positioned along the length of the rail.

To make this work, you'll need to drill a series of holes in the rail. These holes accept a *pin* that's glued into a hole in the

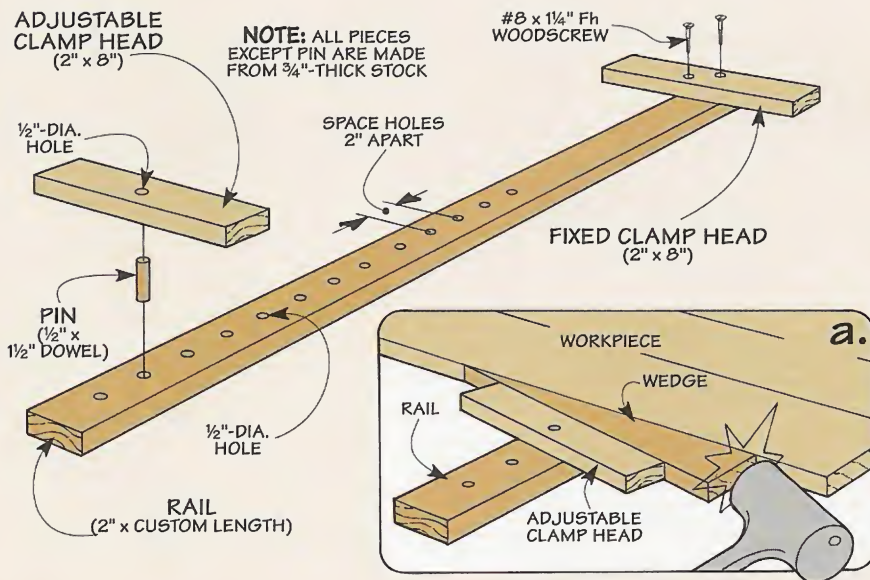

adjustable clamp head. (I used a dowel for the pin.)

In use, this pin allows the adjustable clamp head to pivot as you tap in the wedge, see

detail. The farther you tap in the wedge, the more pressure it applies against the workpiece.

*Peter M. Rath  
Alamogordo, New Mexico*

## Plans Hanger

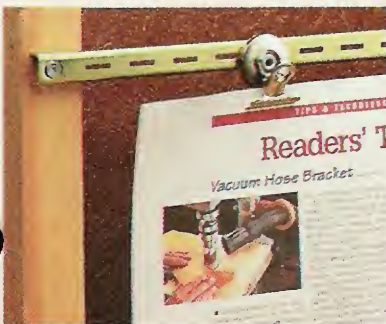

■ When my bench gets cluttered, the plans I'm using often get buried under tools and dust.

But screwing a steel shelf standard to the wall and adding a magnetic clip solves that problem, see photo. Now I just hang up the plans in full view.

*R. B. Himes  
Vienna, Ohio*

## Send in Your Tips

To share your original tips and solutions to problems you've faced, send them to: *ShopNotes*, Attn.: Readers' Tips, 2200 Grand Ave., Des Moines, IA 50312. (Or if it's easier, FAX them to us at: 515-282-6741.)

We'll pay up to \$200 depending on the published length. Please include a daytime phone number so we can call you if we have any questions.

# Portable Hose Reel

*Made of commonly available materials and hardware, this hose reel is inexpensive and easy to build.*

**A**s usual, the hose for my air compressor was tangled like spaghetti on the shop floor. And as I struggled to untie the “knots,” the same old thought crossed my mind. Perhaps it was finally time to break down and buy a hose reel.

The only drawback was the cost. The least expensive hose reel I could find was \$79. And many of them cost more than \$200. (At that price, I figured I’d just get along with a tangled-up air hose.)

**SHOP-MADE REEL.** But about this same time, I received an idea for a *shop-made* hose reel from Tom Accuntius of Sidney, Ohio. With just a few scrap pieces of plywood, dowels, and some standard pipe fittings, he made a hose reel for a fraction of the cost of a store-bought version.

Using a similar idea, I set about building a hose reel of my own, see photo above. It holds a 50-foot length of  $\frac{3}{8}$ " air hose. But the size of the reel can be easily modified for longer hoses.

**AIRTIGHT SHAFT.** Regardless of the length of the hose, the compressor supplies air to it through the *shaft* of the reel, see photo below. That’s where the

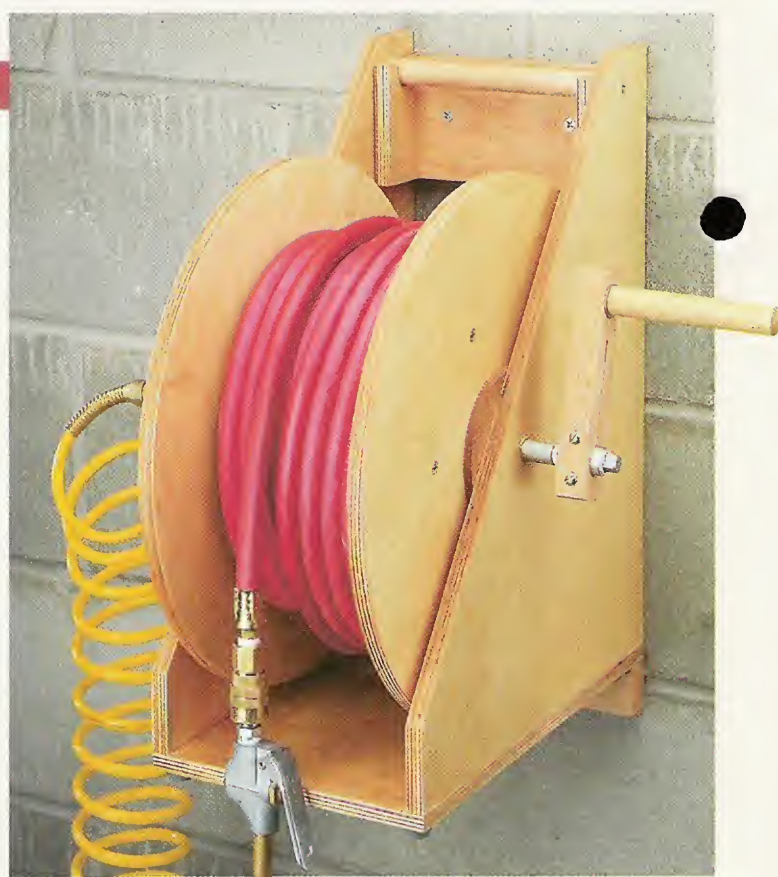

iron pipe fittings come in. They work together to form an airtight shaft that’s connected to the hose. (Pipe fittings are available at most hardware stores. We’ve also put together a complete hardware kit to build the hose reel, see page 31.)

**CRANK.** Besides serving as an air channel, the shaft of the hose reel has a simple wood crank mounted to one end. Turning the crank spins the reel so you can quickly wind up the air hose.

**PORTABLE.** One final note. Although the hose reel hangs on the wall, it’s not permanently attached. Instead, it rests securely on two wall-mounted brackets, see photo on page 7. This makes it easy to remove the hose reel when working outside the shop.



**Airtight Shaft.** A flexible hose directs air from the compressor into the shaft of the hose reel. Made up of standard pipe fittings, the shaft has an elbow

sticking out that’s used to connect the air hose. Turning a crank on the end of the shaft spins the reel so you can quickly wind up the air hose.

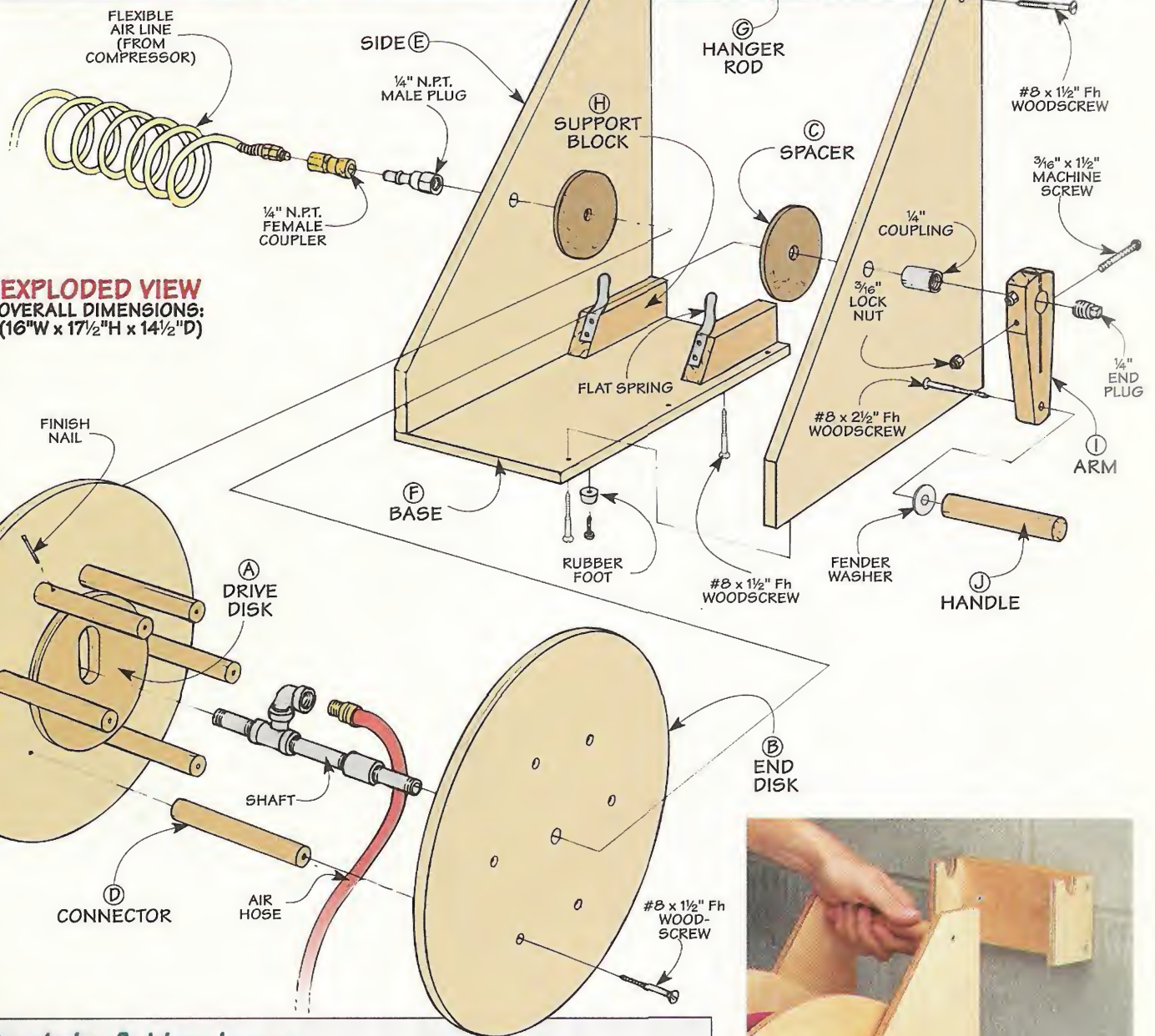

**EXPLODED VIEW**  
**OVERALL DIMENSIONS:**  
 (16"W x 17 1/2"H x 14 1/2"D)

## Materials & Hardware

### Reel & Housing

A Drive Disk (1)	6 1/4 x 6 1/4 - 1/2 Ply.
B End Disks (2)	14 x 14 - 1/2 Ply.
C Spacers (2)	4 x 4 - 1/4 Hardboard
D Connectors (6)	3/4 x 5 1/2 Dowel
E Sides (2)	13 x 17 - 1/2 Ply.
F Base (1)	8 x 13 - 1/2 Ply.
G Hanger Rod (1)	3/4 x 7 Dowel
H Support Blocks (2)	3/4 x 1 1/2 - 5

### Crank Assembly

I Arm (1)	3/4 x 1 1/4 - 5 3/4
J Handle (1)	3/4 x 4 1/2 Dowel

### Hanging Brackets

K Back (1)	3/4 x 3 1/2 - 5 7/8
L End Pieces (2)	2 1/2 x 3 1/2 - 1/2 Ply.
M Cleat (1)	3/4 x 1 1/2 - 8
N Pin (1)	5/16 x 1 Dowel

- (26) #8 x 1 1/2" Fh Woodscrews
- (1) #8 x 2 1/2" Fh Woodscrew
- (4) #8 x 3/4" Ph Sheet Metal Screws
- (2) 3/16" x 1 1/2" Machine Screws
- (2) 3/16" Nylon Lock Nuts
- (1) 5/32" I.D. x 7/8" Fender Washer
- (2) 2 3/4" x .032" Flat Spring
- (1) 1/4" x 3 1/2" Pipe Nipple
- (2) 1/4" x 2 1/2" Pipe Nipples
- (2) 1/4" Pipe Couplings
- (1) 1/4" Tee Fitting
- (1) 1/4" Street Elbow
- (1) 1/4" End Plug
- (6) #4 Finish Nails
- (4) 3/4"-Dia. Rubber Feet



Portable. Two simple brackets let you hang the hose reel on the wall or remove it to use away from the shop.

# Reel & Housing

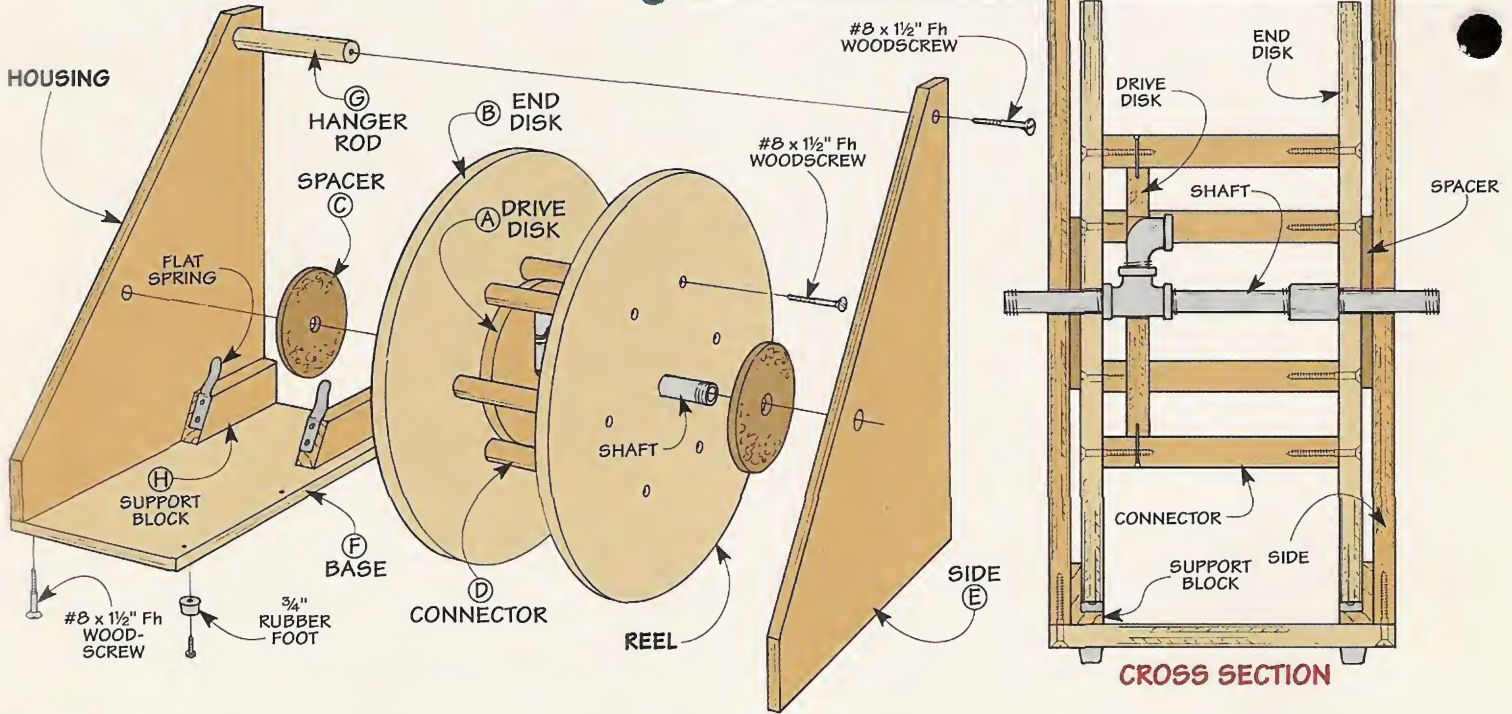

▲ To produce an airtight seal, wrap the threads of the pipe fittings with Teflon tape.

The hose reel is made up of two main parts. A circular *reel* holds the air hose, see drawing. And a triangular-shaped *housing* supports the reel.

## REEL

To direct air from the compressor to the air hose, the reel starts out as an assembly made up of iron pipe fittings, see Fig. 1.

**SHAFT.** Besides acting as an air channel, these fittings form the *shaft* of the reel. To prevent air from leaking, it's important to wrap the threads of the fittings

with Teflon tape before assembling the shaft, see margin.

**DRIVE DISK.** The next step is to add a plywood *drive disk* (A), see Fig. 1. It transfers the rotation of the shaft to the reel. To make this work, the tee fitting and elbow of the shaft fit tightly in a slot cut in the drive disk, see Fig. 1a. Note: You may have to file the slot to get a good fit.

**END DISKS.** Now you can turn your attention to the two *end disks* (B), see Fig. 2. These are large plywood disks that keep the air hose from slipping off the reel.

An easy way to make two identical disks is to start by carpet-taping a pair of square blanks together. This also ensures proper alignment of the holes that are drilled next.

To accept the ends of the shaft, there's a centered hole in each disk. You'll also need to drill a series of holes in a circular pattern for the screws that will be used to assemble the reel.

Now it's just a matter of cutting the end disks to rough shape and sanding the edges smooth, refer to page 14.

**SPACERS.** While I was at it, I also made two *spacers* (C), see Fig. 2. These are large hardboard "washers" with a hole in the center. The spacers prevent the end disks from rubbing on the housing as the reel spins around.

**CONNECTORS.** All that's left to complete the reel is to add a half dozen *connectors* (D) made from 3/4"-dia. dowels. Besides connecting the end disks, the dowels form the hub of the reel that the air hose wraps around.

To determine the length of the dowels, you'll need to measure the

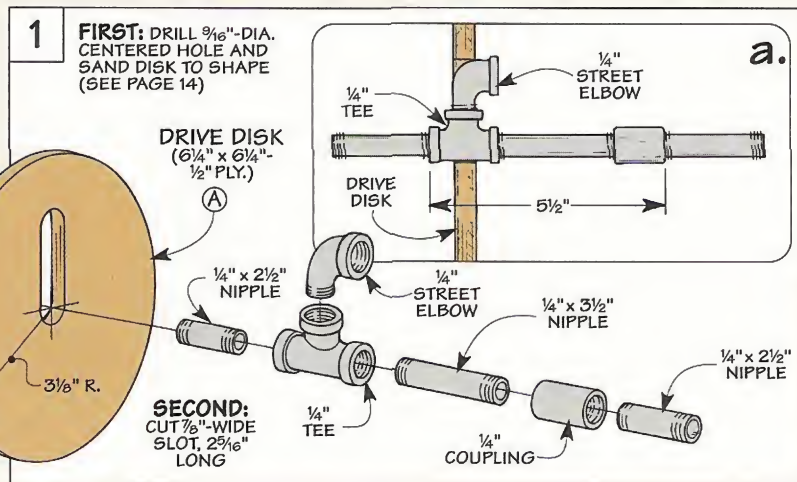



distance between the *outside* ends of the tee and the coupling, see Fig. 1a. (In my case, this was 5½".)

**ASSEMBLY.** Now you're ready to assemble the reel. Start by screwing the dowels to one end of the reel. Then slip the drive disk and shaft between the dowels and attach the other end. To secure the drive disk, I drilled a pilot hole in each dowel and drove in a finish nail, see Fig. 2a.

**HOUSING**

With the reel complete, all you need is a way to support it so it can spin around. That's the job of the housing.

**SIDES.** The housing starts out simply enough. It's just a pair of triangular-shaped *sides (E)* made from ½" plywood, see Fig. 3. To accept the ends of the shaft there's a hole drilled in each side.

**BASE & HANGER ROD.** The sides are joined with a plywood *base (F)* and a *hanger rod (G)* made from a dowel. Besides serving as a convenient handle, the dowel is used to hang the hose reel on the wall.

Both the base and hanger rod are screwed to the sides with the reel sandwiched between. Just don't forget to slip a spacer (C)

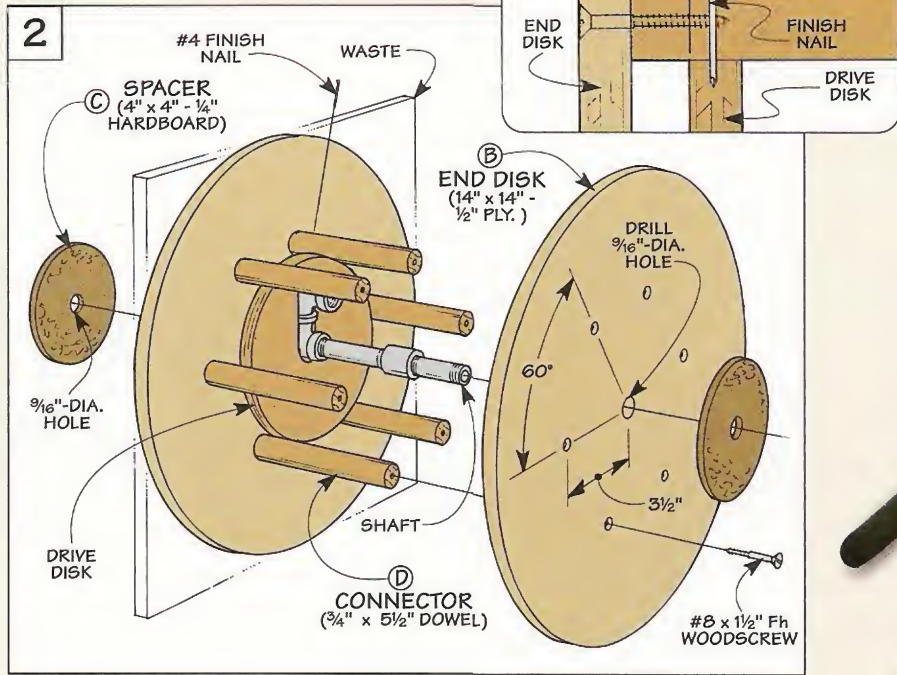

over each end of the shaft first.

At this point, the reel should spin easily. The problem is it will continue to spin after you stop pulling on the hose. (This would tangle up the hose like fishing line on an old bait-casting reel.)

**SPRINGS.** To prevent this, I added a pair of flat springs, see margin. These springs act like brakes by pressing against the end disks, see Fig. 4.

Each spring is screwed to a hardwood *support block (H)*, see Fig. 4a. I started with an extra-long block that's mitered on one end so it fits below the end disk.

To apply just the right amount of pressure, the idea is to position the block so the spring bends back just a bit, see Fig. 4b. After marking the block and trimming it flush, simply glue and screw it to the housing.

▲ The flat springs used to "brake" the hose reel are available from:

- Small Parts, Inc. (Part No. FS-8) 800-220-4242

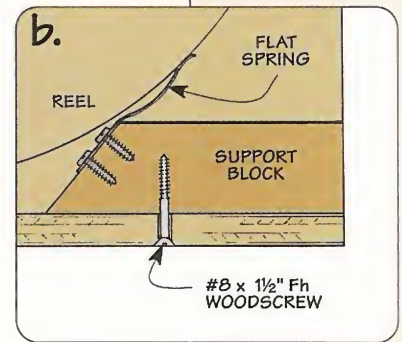
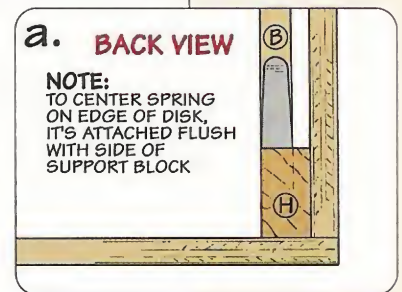
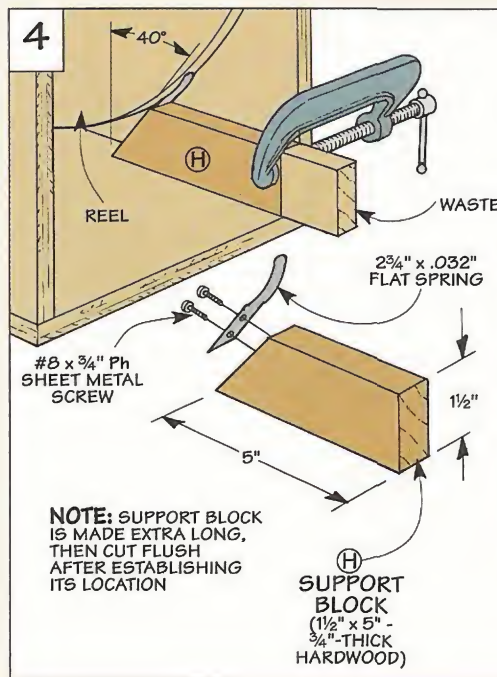
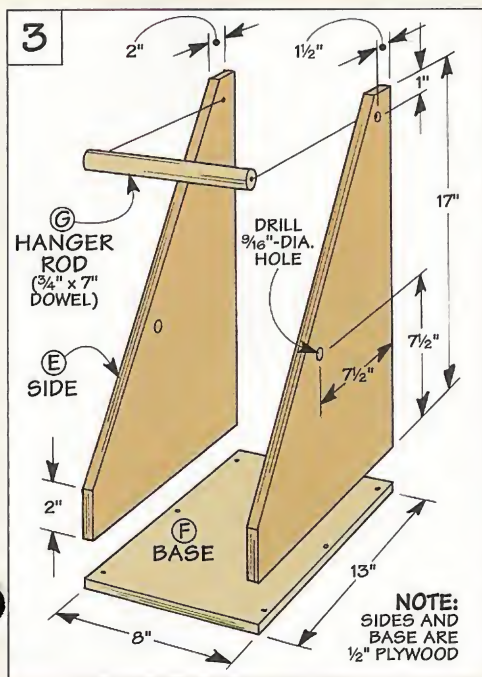

# Crank Assembly

At this point, the reel is enclosed by the housing. But it's not ready to use yet. It still needs a crank so you can wind the hose onto the reel. The crank consists of two pieces: an *arm* that fits over the shaft, and a *handle* that turns the crank, see Fig. 5.

**MORE PLUMBING.** But first there's a bit more plumbing to do. To prevent air from escaping from the end of the shaft where the crank is located, you'll need to thread on a coupling and install an end plug. Note: I threaded a male plug that accepts a female coupler to the opposite end of the shaft, see Step 1 on next page and Exploded View on page 7.

**ARM.** With the fittings in place, you're ready to add the *arm* (I). It's nothing more than a piece of 3/4"-thick hardwood. (I used maple.)

To allow the handle to spin freely once it's attached, there's an *oversize* hole drilled near one end of the arm, see Fig. 6. And a large (7/8"-dia.) hole near the opposite end is sized to fit tightly around the coupling.

But even with a tight fit, the arm could still slip as you turn the crank. So it's held in place with machine screws and lock nuts. The screws pass through holes in the edge of the arm, see Fig. 6.

To allow the screws to apply clamping pressure, I cut a long kerf in the arm. This way, the

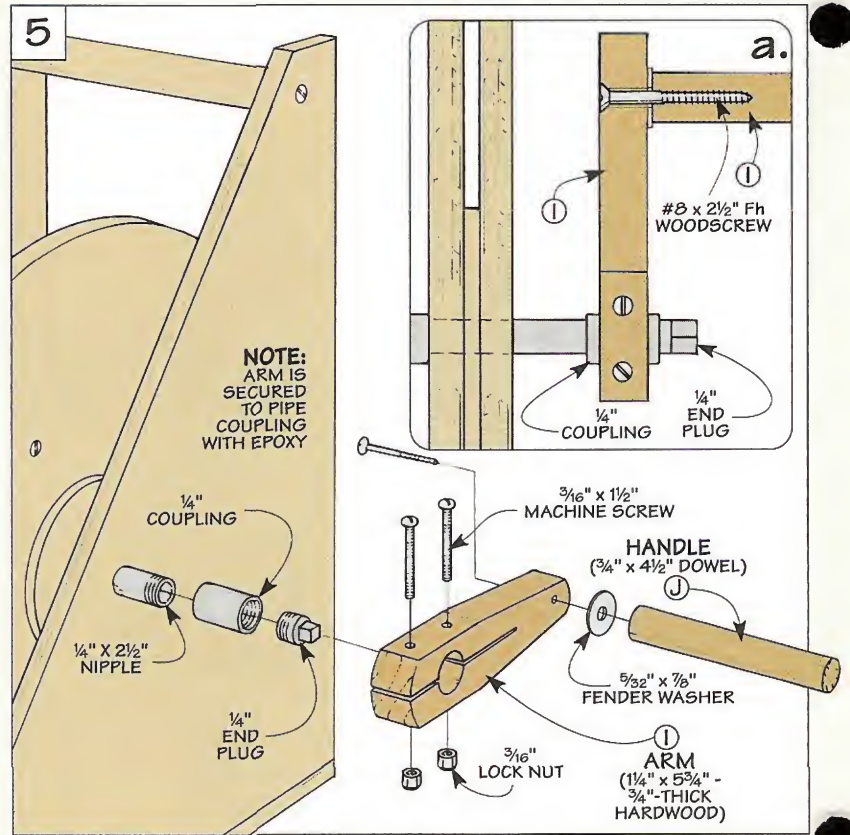

arm will "pinch" the coupling as you tighten the lock nuts.

All that's left to complete the arm is to cut it to final shape. The narrow end is formed by cutting a gradual taper on each edge. Then I sanded a gentle curve on both ends, see Fig. 6.

Now it's just a matter of attaching the arm. To provide extra insurance against slipping, it's held in place with epoxy.

**HANDLE.** Before attaching the arm, it's easiest to add the *handle* (J), see Fig. 5. This is just a dowel that's screwed to the arm.

Why doesn't the handle come unscrewed? Because the screw passes through the oversize hole in the arm. But it threads tightly into a pilot hole drilled in the end of the handle. As a result, the handle spins freely (without loosening) as you turn the crank.

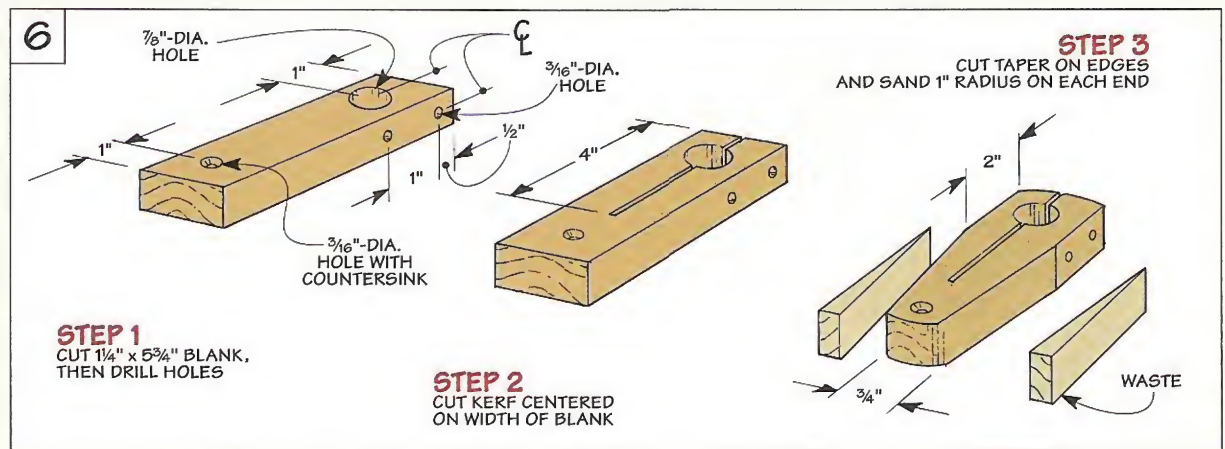

# Hanging Brackets

The hose reel is designed to hang securely on the wall. Yet it's easily removed if you need to use your compressor outside the shop.

To accomplish this, the hose reel is supported by two hanging brackets. An *upper bracket* cradles the hanger rod (dowel) at the top of the housing, see Fig. 7. And a *lower bracket* holds the base (F) in place.

**UPPER BRACKET.** The upper bracket is a simple, U-shaped assembly. It consists of a hardwood *back* (K) and two *end pieces* (L) made from 1/2" plywood, see Fig. 7.

Before gluing and screwing the bracket together, it's easiest to cut a curved notch in each end piece, see Fig. 7a. When the bracket is screwed to the wall, these notches form a "saddle" for the hanger rod.

The upper bracket provides plenty of support for the hose reel all by itself. But the housing would tend to "kick" away from the wall on the upward stroke of the crank. That's where the lower bracket comes in.

**LOWER BRACKET.** Basically, it's just a hardwood *cleat* (M) with a

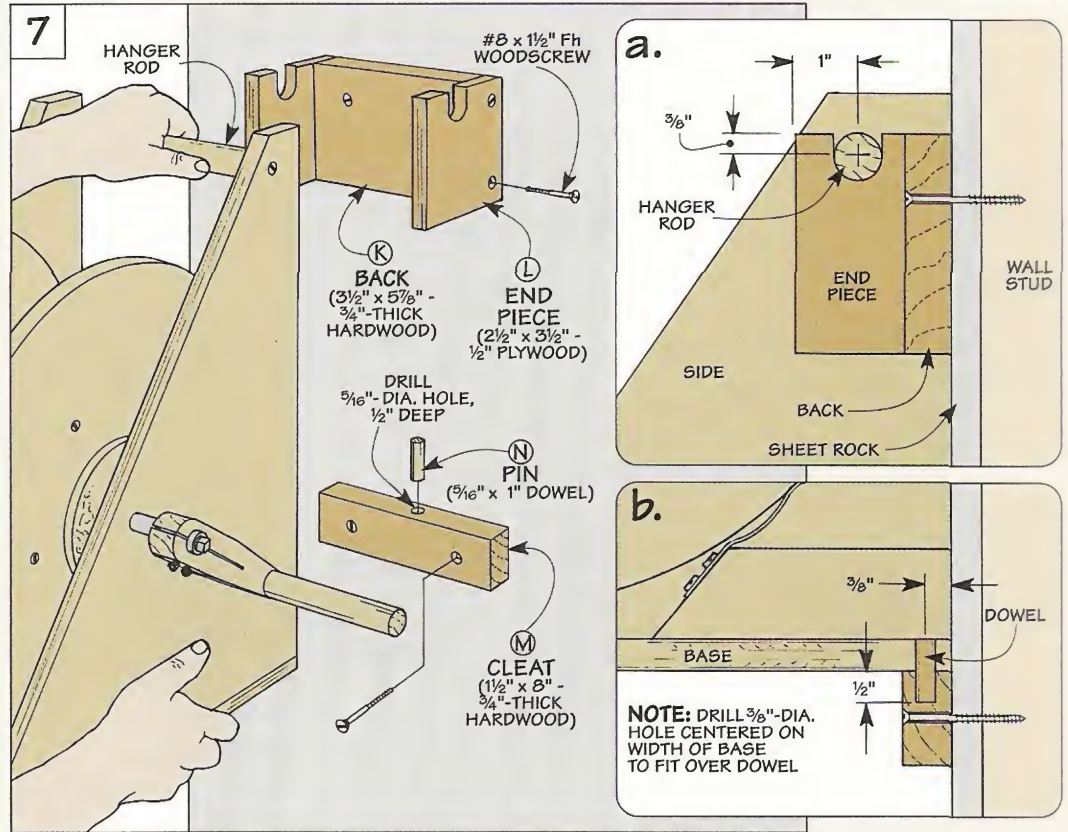

*pin* (N) glued into a hole in the top edge. (I used a dowel.) When the cleat is screwed to the wall, the pin fits in a hole drilled in the base (F), see Fig. 7b. This holds the housing tightly against the

wall as you crank the reel.

**HANG REEL.** The two brackets make it a snap to hang (or remove) the hose reel. Just lower it down onto the brackets. Or lift it up and away from the wall. 🛠️

## FINAL HOOK-UP



**1** When hooking up our air compressor, we used a flexible air line with a coupler on the end. It fits over a "plug" that's threaded onto the shaft.

**2** To attach the hose, first twist it counterclockwise (looking at the end of the hose) like you're wringing out a towel. Then thread it into the elbow.

# Drafting Tools

## ... a basic set



T-SQUARE



TRIANGLES

I've known woodworkers who can take a rough sketch and build a project without making any mistakes. But it doesn't work that way for me.

To help anticipate construction problems and avoid any "surprises," I like to have an accurate, detailed drawing of the project in hand *before* making my first cut.

Sometimes that means modifying a plan I've seen somewhere else. Other times, I'll make a shop drawing from "scratch." Either way, it pays to have a basic set of drafting tools.

### T-SQUARE & TRIANGLES

It's hard to imagine even sitting down at a drawing board without two basic tools — a T-square and a set of drafting triangles, see photo above.

**T-SQUARE.** A *T-square* serves as a straightedge for drawing all the horizontal lines.

But what's more important, it ensures that these lines are *parallel* to each other.

One thing to look for when selecting a T-square is that the blade is long enough to extend across your drawing board. Also, it's a good idea to get one with a plastic edge that you can see through. This makes it easy to line up on a point (or line) below.

Note: For a look at a shop-made T-square with a Plexiglas blade, refer to the article on page 16.

**TRIANGLES.** Regardless of the type of T-square, you won't get much drafting done without a couple of *triangles* to go with it. A 45° triangle and one with a 30° and a 60° angle will take care of most of the angled lines you need to draw, see photo above.

But where a triangle is really indispensable is when drawing vertical lines. With the triangle resting on the T-square, all the vertical lines you draw will be *perpendicular* to the horizontal lines (and *parallel* to each other).

You'll find triangles in a wide range of sizes. For most drawings, an 8" triangle works fine. (It's also a convenient size for setting up the miter gauge on your table saw.)

Even the color of a triangle

may make a difference. A pink, plastic triangle makes the pencil lines on the drawing easier for me to see than one made of clear or gray plastic. Plus, it's not as apt to get lost in the shuffle.

### DRAWING CURVES

Although straight lines provide the groundwork of a drawing, it's the curved lines that refine the design. So you'll need several tools for drawing curved lines as well.

**CIRCLE TEMPLATE.** A quick way to draw a small circle or arc is to use a plastic *circle template*, see photo at left. (And it sure beats trying to find a jar or lid with the correct size radius.)

Once again, you don't need every size of circle template available. The one I use has circles that range in size from 3/64" dia. up to 2". And the size increases in such small increments that I can usually find the radius I need.

A circle template usually ends up doing double-duty in the shop as well. The centerlines around the circles make it a snap to find the center of a dowel. And it's a quick way to lay out a radius on the corner of a workpiece (if you don't happen to have a dime).

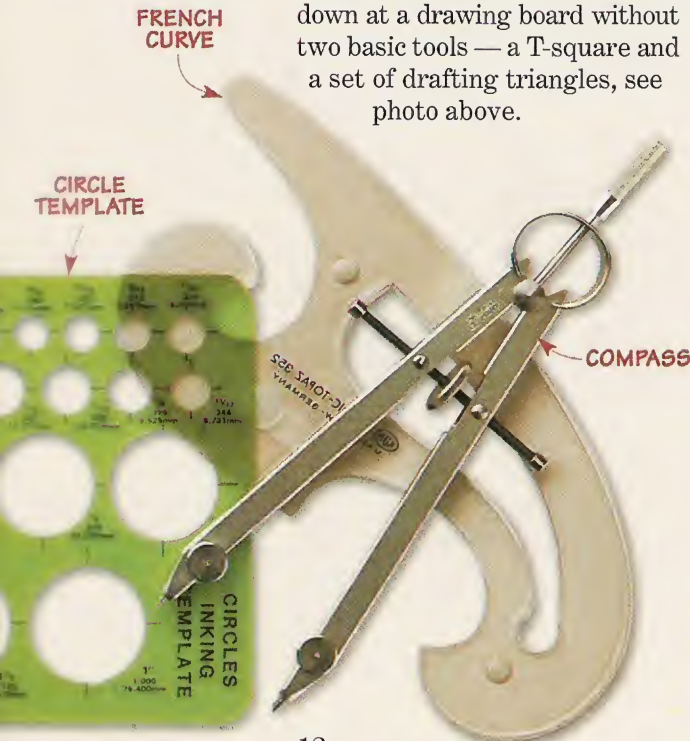

FRENCH CURVE

CIRCLE TEMPLATE

COMPASS

**COMPASS.** In addition to a circle template, you'll also need a *compass* for drawing large circles and arcs. To produce accurate results, the important thing is to get a compass with legs that adjust easily *and* lock in place.

I'd recommend the type that has a threaded rod connecting the legs and a center adjustment wheel, see bottom photo on page 12. The center wheel lets you "tweak" the compass to the exact radius that's needed. And the threaded rod keeps the legs from spreading farther apart (or squeezing together).

As simple as it sounds, the way the lead in the compass is sharpened can affect the quality of the line. To produce a fine line, I *sand* the lead to a "chisel edge" instead of a point.

**FRENCH CURVE.** A circle template or compass works great for drawing a simple curved line (one with a *single* radius.) But you may need to draw a line that's made up of a series of flowing curves — each one with a *different* radius.

That's when a *french curve* comes in handy. It's a template

with a series of curves that make it look like a plastic scroll saw project, see lower photo on page 12. The important thing about this template is that the radius of the curves changes continuously from one point to the next. So you can use it to draw freeform curves.

The idea is to draw *one* section of the curve at a time. What works well is to draw the curved line freehand first (very lightly). Then find a portion of the template that matches the shape of the line. After darkening that part of the line, move the template and repeat the process.

**SCALE & PROTRACTOR**

All it takes to round out a basic set of drafting equipment is a scale and a protractor.

**SCALE.** It's a cinch you won't be able to draw every project to actual size — some are just too large to fit on the paper. So a *scale* provides an accurate way to reduce the size of the drawing without changing the proportions.

The type of scale I use is called an *architect's scale*. Basically, it's

a triangular "ruler." Each face of the ruler has measurements drawn to a different scale.

For example, if you want to make a drawing that's half as large as the project, measure directly off the half-scale (1/2). If that's still too large, you could use the quarter (1/4) or eighth-scale (1/8). (There are twelve scales altogether.)

Regardless of the scale, the nice thing is there's no arithmetic involved. You simply mark the length of a line directly off one of the scales.

**PROTRACTOR.** Finally, it seems there's always a project that requires drawing an "odd" angle (one you can't draw with either of the drafting triangles). So I always make it a point to keep a *protractor* on hand. 

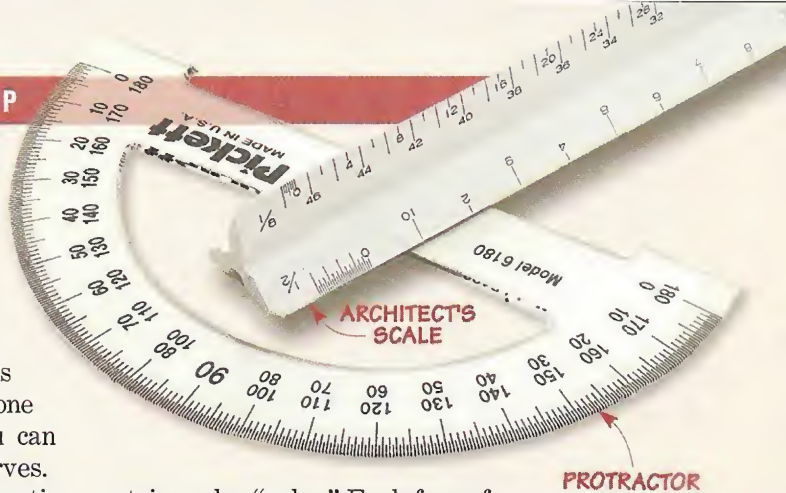

**Drafting Supplies**

The best way to end up with a crisp, clean drawing is to start with supplies used especially for drafting.

**PAPER.** One important thing is a high quality paper. I use a 100% rag paper called *marker paper*. It's more expensive, but it erases well. And if you get the type that's translucent, you can trace through it.

**TAPE.** The paper is attached to a flat surface (hardboard is fine) with drafting tape. This tape has enough "tack" to hold the paper, but not enough to tear it when you peel it up.

**PENCIL.** Another thing to consider is the pencil. To produce a fine, consistent line, I get the best results with a mechanical pencil. A hard (2H) lead isn't as apt to smudge the drawing as a softer lead.

**FIXES.** Finally, a plastic eraser and metal shield will let you fix mistakes without removing lines you want. And don't forget a brush to sweep off dust.

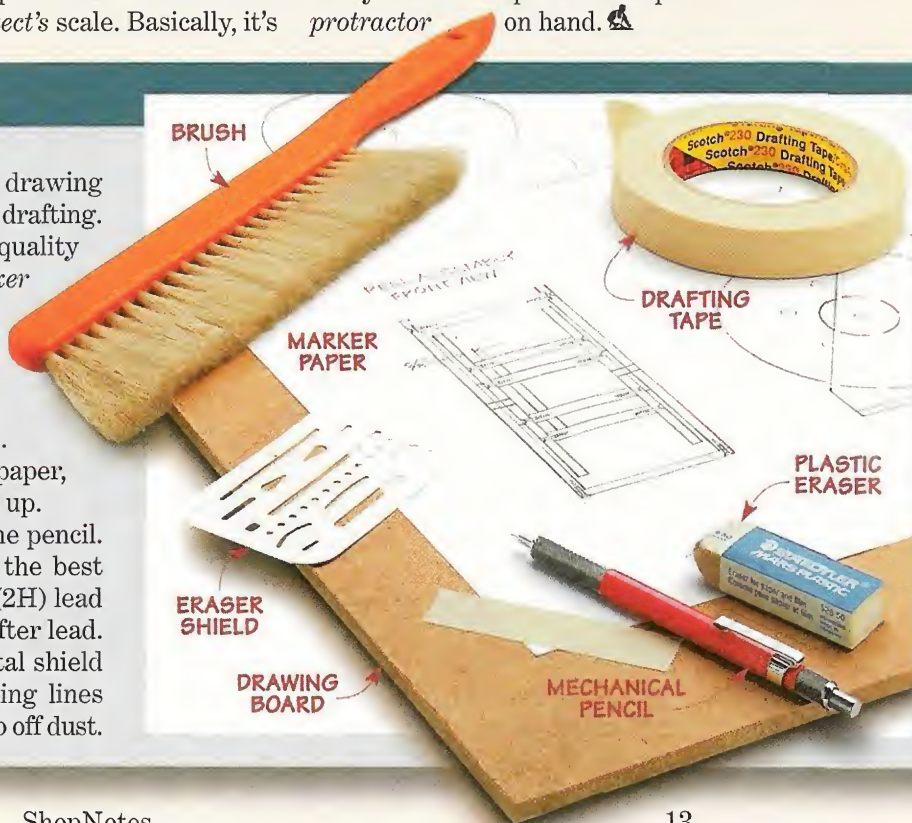

## SANDING JIG

■ After cutting each of the disks for the Hose Reel (page 6) to rough shape, the edges are sanded smooth. To make quick work of this task (and to end up with perfectly round disks), I used a simple sanding jig and a disk sander, see photo.

**JIG.** Basically, the jig consists of three parts: an MDF *base*, an adjustable hardwood *runner*, and a *pivot pin* made from a dowel, see Fig. 1.

The runner slides in a groove cut in the base. This way, you can

adjust the position of the pivot pin for different size disks.

The pivot pin is glued into a counterbore in the runner. In use, the workpiece fits over the pivot pin. But there's a problem. The center holes in the disks are  $\frac{9}{16}$ " diameter. And I couldn't find a dowel that size.

So instead of a  $\frac{9}{16}$ " hole, I drilled a counterbore in the runner to fit a  $\frac{1}{2}$ "-dia. dowel. Then, to get a snug fit, I wrapped the dowel with several layers of masking tape.

**SETUP.** Using the sanding jig is a simple process. Start by clamping the base of the jig  $\frac{1}{16}$ " from the



face of the disk sander, see Fig. 1. **SAND DISK.** Then simply fit the workpiece over the pivot pin and slide the runner forward until the edge contacts the spinning disk. At this point, clamp the runner in place and sand the disk by rotating it clockwise, see Fig. 2.

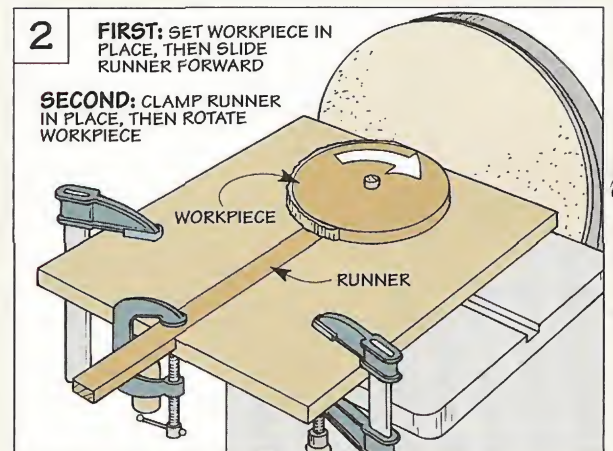
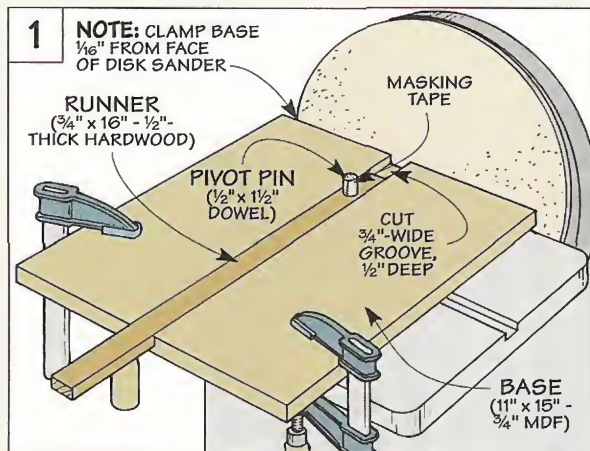

## DRILLING CENTERED HOLES IN DOWELS

■ Drilling a hole is usually a simple task. But when it comes to drilling a centered hole in a round workpiece, it's easy to be just a hair off.

So when it came time to drill the centered holes in the dowel guides for the Drafting Table (page 16), I used a simple trick to center the holes perfectly, see photo at left.

Start by clamping a scrap to the table of the drill press, see Fig. 1. I first drilled a counterbored hole to match the diameter of the dowel.

This way, when you slip the dowel into the counterbore, it's perfectly centered under the tip of the drill bit. After installing a smaller drill bit, it's a simple

matter to drill a hole through the dowel, see Fig. 2. Note: To keep the dowel from spinning, clamp a handscrew around it to hold it securely in place.

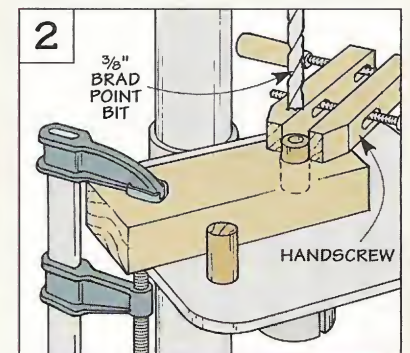
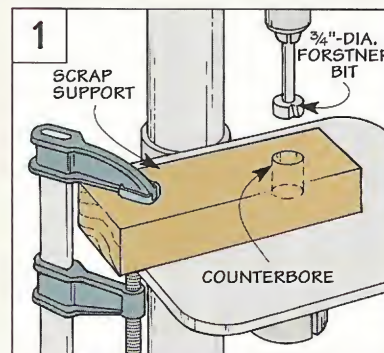

## CUTTING SLOTS IN METAL

■ When working on the aluminum sole plate for the Scratch Stock (page 24), I reached a point where I needed to cut a long slot and a rectangular opening.

Now if the piece was made of wood, I'd just drill a series of overlapping holes and clean up the edges with a chisel.

But with metal, it's not that simple. That's because a twist bit will tend to "catch" as you drill

the overlapping hole. This pulls the bit off course and chews up the edges of the opening. So to produce a clean cut, I used a slightly different approach.

**WEB.** Instead of drilling overlapping holes, the idea is to leave a narrow "web" between each one, see photo at right. Since there's not much material, it's easy to break through the web with a small round file, see Fig. 1.



**FILE EDGES.** To complete the slot, an ordinary flat file will make quick work of cleaning up the edges so they're smooth and straight, see Fig. 2.

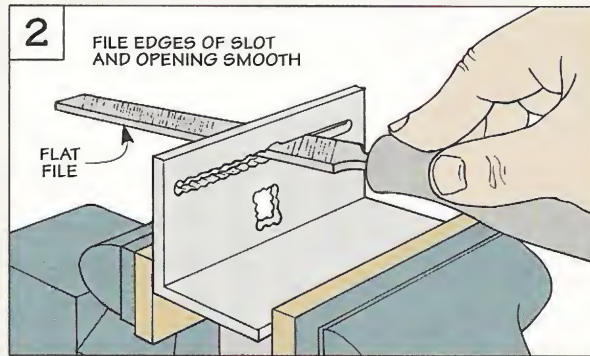
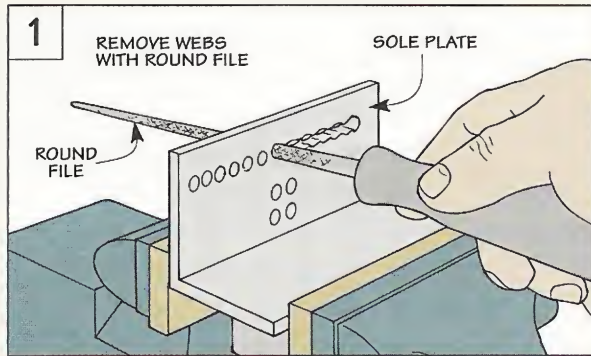

## T-SQUARE BLADE

■ The T-square on the Drafting Table (page 16) has a long blade made of 1/4" Plexiglas, see margin. Since this blade serves as a straightedge for drawing all the horizontal lines, I wanted the edges to be smooth and straight.

**TEMPLATE.** To accomplish that, I used a 1/4" hardboard template and a table-mounted router. When making the template, it's worth taking the time to sand the edges nice and smooth. That's because

any irregularities will be transferred to the edge of the blade.

**ATTACH TEMPLATE.** After the template is completed, it's attached to an oversized piece of Plexiglas with carpet tape. Note: To ensure the T-square is oriented properly once it's complete, attach the template to the Plexiglas as shown in Fig. 1.

**ROUGH SHAPE.** The next step is to cut the Plexiglas to within 1/8" of the template, see Fig. 1.

**FLUSH TRIM.** Then, to trim the Plexiglas to the exact size and shape of the template, I used a flush trim bit in the router table, see Figs. 2 and 2a.

**BEVEL.** The only problem is this leaves a square edge that's difficult to set a pencil against. So I followed up by using a chamfer bit to rout a bevel all around the blade, see Fig. 2b.

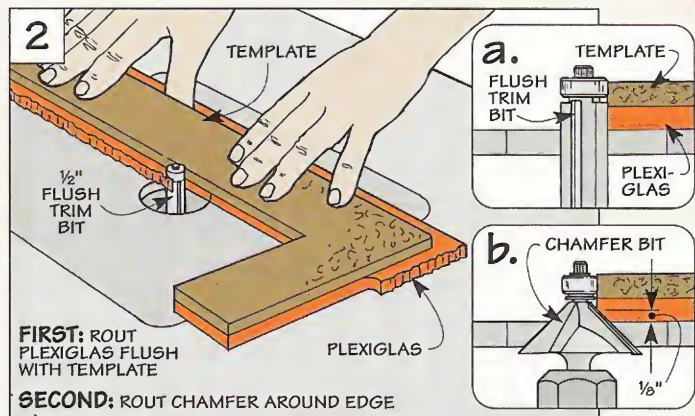
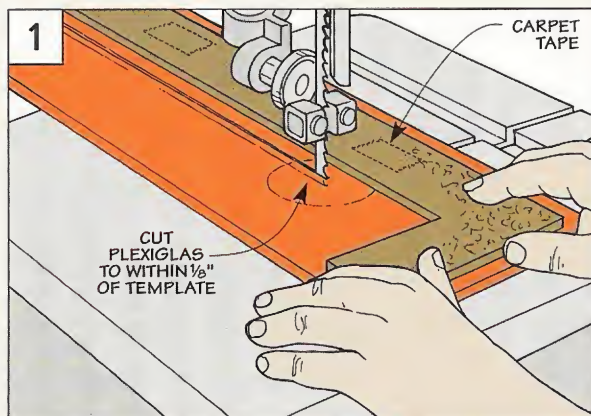
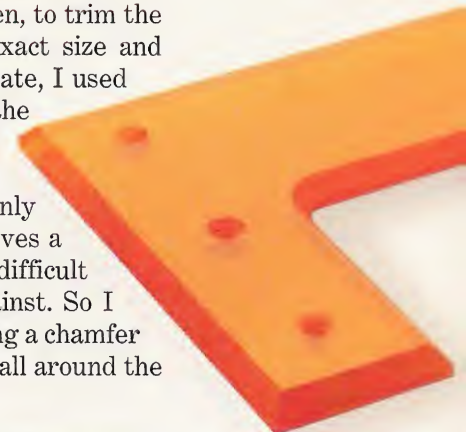

# Fold-Down Drafting Table

*This sturdy, wall-mounted drafting table won't take up a lot of space in your shop. It folds into a cabinet that's only 4" deep.*

I've always wanted to have a large drafting table in the shop. I just couldn't justify giving up the floor space it would require.

That's why I like this drafting table, see photo at right. It takes up *no* floor space. Yet it has a *large* drawing surface — big enough to make drawings on a 19" x 24" piece of drafting paper (or spread out an entire section of the morning newspaper).

**FOLDING TABLE.** But as much as I like the large size of this table, there's something else about it that's even better. When I'm done working on a drawing, the table folds up neatly into a wall-mounted cabinet, see photo C below.

This cabinet only sticks out 4" from the wall. But as slim as it is, it's enough to house a simple pivot system that lets you slide the table down and swing it out at the same time.

The whole process only takes a few seconds. So if I need to work out a joinery detail or draw a



cutting diagram, I can get right to work.

**STORAGE.** And there's no need to search for my drafting tools. They're stored in a convenient compartment directly above the table, see photo A.

**T-SQUARE.** One of these tools is a T-square that's designed especially for this drafting table, see photo B. It rides in a track that keeps the head of the T-square tight against the table. So there's one less thing to worry about when making a drawing.

**BORCO.** Finally, to produce a smooth drawing surface, we covered the table with a sheet of vinyl material called *Borco*. (For more information about *Borco*, refer to Sources on page 31.)

**A. Storage** ▶

A flip-up door provides easy access to a storage compartment that holds all your drafting tools.



**B. T-Square** ▶

To keep this shop-made T-square perpendicular to the edge of the table, it rides in a metal track.

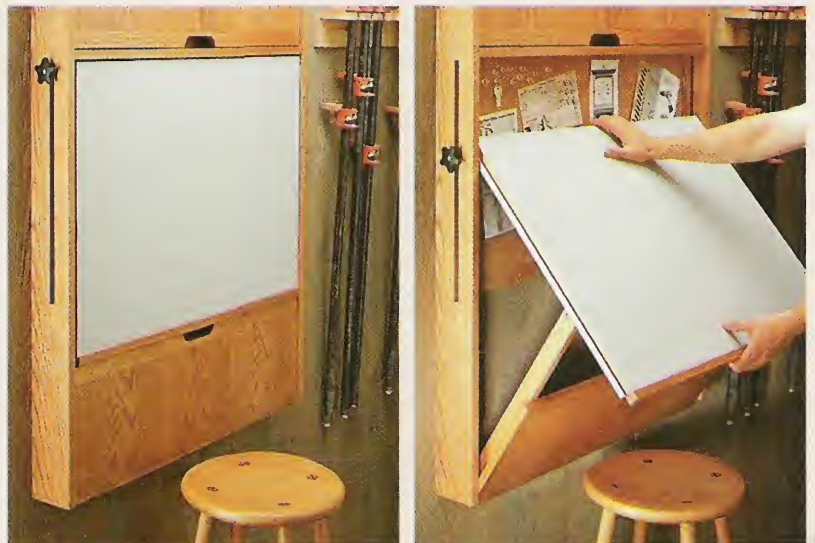

**C. Folding Table.** In the folded position (left), the drafting table is housed in a compact, wall-mounted cabinet. To make a drawing, a special pivot system lets you swing the table out of the cabinet (right).



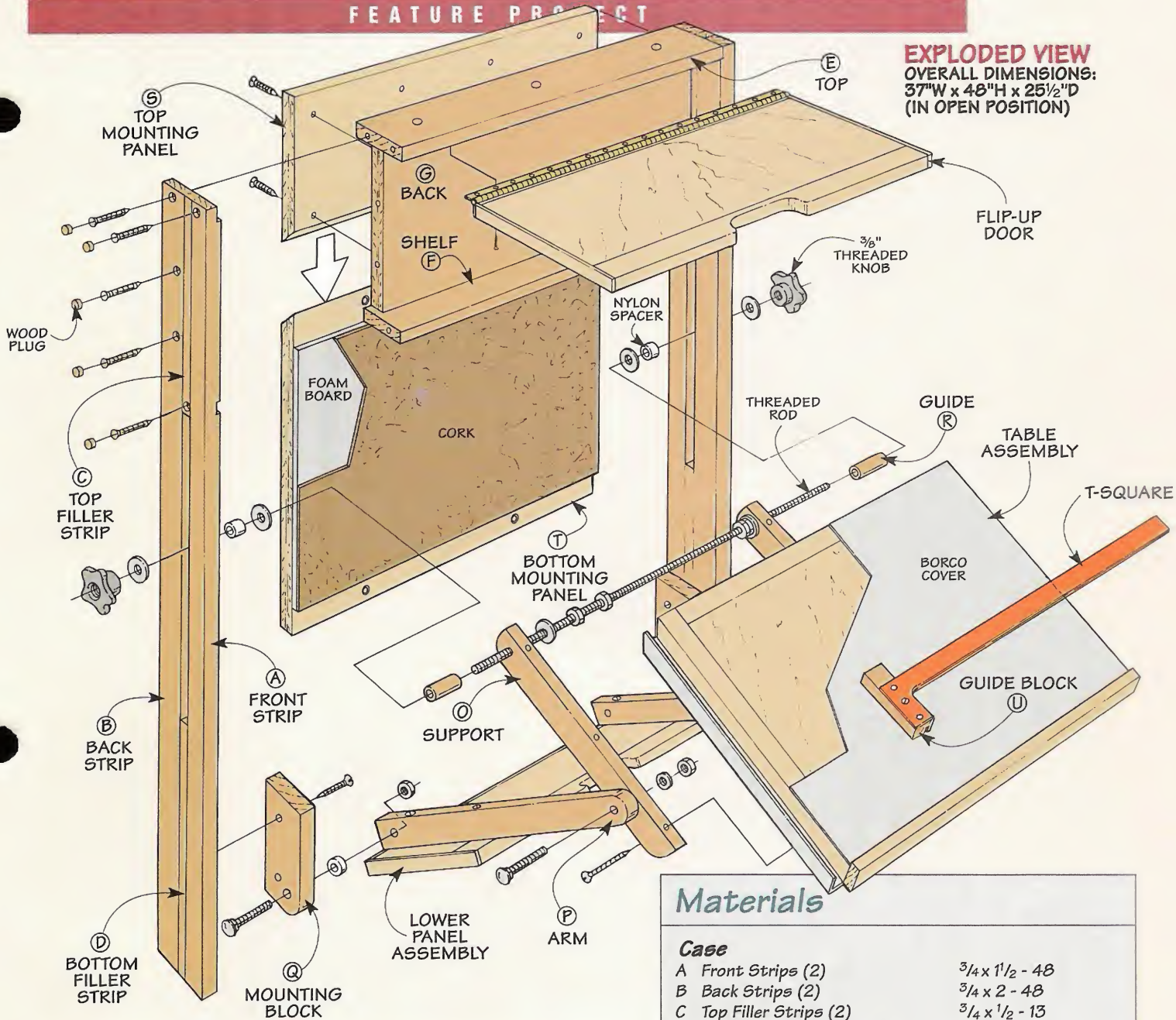

**EXPLODED VIEW**  
**OVERALL DIMENSIONS:**  
 37"W x 48"H x 25½"D  
 (IN OPEN POSITION)

### Hardware & Supplies

- (26) #8 x 2" Fh Woodscrews
  - (12) #8 x 1¼" Fh Woodscrews
  - (5) #6 x ½" Rh Woodcrews
  - (1) #6 x 5/8" Fh Woodscrew
  - (2) 3/8"-16 Threaded Knobs
  - (2) 3/8" x 2½" Carriage Bolts
  - (2) 3/8" x 2" Carriage Bolts
  - (1) 3/8"-16 Threaded Rod (36" long)
  - (8) 5/16" Flat Washers
  - (4) 3/8" Hex Nuts
  - (4) 3/8" Lock Nuts
  - (1) 1½" x 33" Piano Hinge w/screws
  - (2) ¼" x 3/4" Metal Rod
  - (2) 3/8" I.D. x 1" O.D. Nylon Spacers (3/8" Long)
  - (2) 3/8" I.D. x ½" O.D. Nylon Spacers (5/8" Long)
  - (1) ½" x 1" - 23¼" Alum. Channel (1/8" Thick)
  - (16) 3/8" Wood Plugs
  - (1) 18" x 33¼" - ¼" Foam Board
  - (1) 18" x 33¼" - 1/8" Cork
  - (2) Magnetic Catches w/Strikes
  - (1) 24" x 36" Vinyl Drawing-Board Cover (Borco)
  - (1) 4½" x 32" Plexiglas (¼" thick)
- Note: For a hardware kit to build the Drafting Table, see Sources on page 31.

### Materials

#### Case

- |                            |                      |
|----------------------------|----------------------|
| A Front Strips (2)         | ¾ x 1½ - 48          |
| B Back Strips (2)          | ¾ x 2 - 48           |
| C Top Filler Strips (2)    | ¾ x 1½ - 13          |
| D Bottom Filler Strips (2) | ¾ x 1½ - 16          |
| E Top (1)                  | ¾ x 4 - 33½          |
| F Shelf (1)                | ¾ x 3¼ - 33½         |
| G Back (1)                 | 1¼ x 33¼ - ¾ Ply.    |
| H Upper/Lower Panel (2)    | 9½ x 32½ - ¾ Ply.    |
| I Upper/Lower Rails (2)    | ¾ x 1½ - 32½         |
| J Edging                   | ¼ x ¾ (9 Linear Ft.) |

#### Table

- |                             |                    |
|-----------------------------|--------------------|
| K Table Panel (1)           | 20¾ x 30½ - ¾ Ply. |
| L Rails (2)                 | ¾ x 1½ - 30½       |
| M Stiles (2)                | ¾ x 1½ - 23¼       |
| N Pencil Stop (1)           | ¾ x 1 - 32½        |
| O Supports (2)              | ¾ x 1½ - 22        |
| P Arms (2)                  | ¾ x 1½ - 20        |
| Q Mounting Blocks (2)       | ¾ x 3 - 8          |
| R Guides (2)                | ¾ x 1³/16 Dowel    |
| S Top Mounting Panel (1)    | 10 x 33¼ - ¾ Ply.  |
| T Bottom Mounting Panel (1) | 22 x 33¼ - ¾ Ply.  |
| U Guide Block (1)           | ¾ x 1½ - 7         |



and screwed in place so it's flush with the back edge of the shelf, see Side View on page 18.

**DOOR.** Now all that's left is to add a flip-up door to the front of the compartment. Note: It's identical to a lower panel assembly that's added later. So I made the door *and* the lower panel assembly at the same time.

Each one is a plywood *panel* (H) that's wrapped with strips of hardwood, see Fig. 2. A tongue on one edge of each panel fits a groove in a wide *rail* (I). The other three edges are covered with thin strips of *edging* (J).

**PULL.** To create a finger pull, I cut a curved notch in the rail. Attaching the door with a piano hinge and adding magnetic catches completes the case.

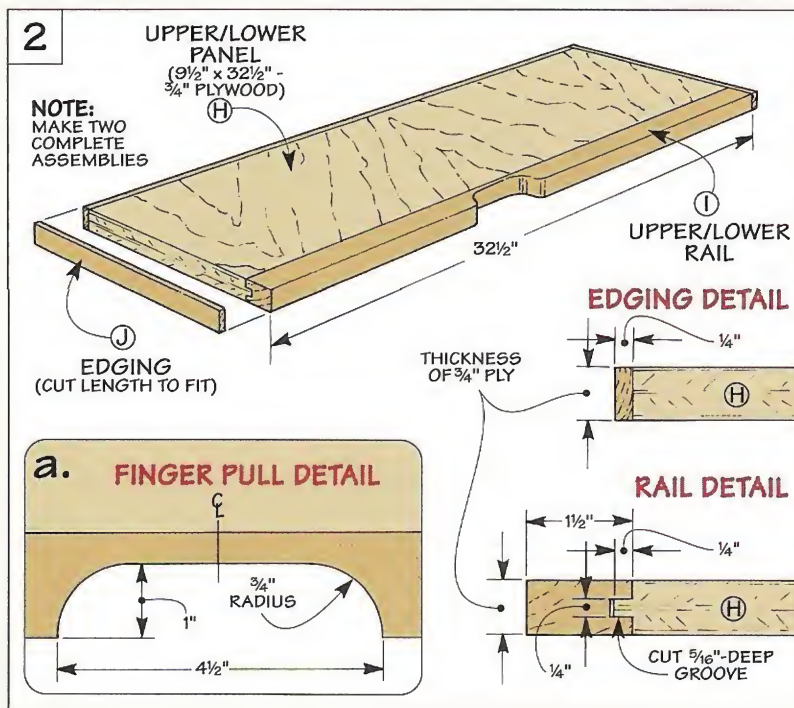

## Table

With the case complete, you can turn your attention to the table. Besides providing a large drawing surface, the table has a built-in metal channel on one edge to guide the T-square.

Here again, the table is made up of a plywood *panel* (K) that's surrounded with strips of hard-

wood, see Fig. 3. But this time, all four edges are rabbeted to form a tongue all the way around.

**RAILS & STILES.** These tongues fit in grooves cut in the *rails* (L) and *stiles* (M). You'll also need to rabbet the ends of the rails to form a short (stub) tenon that fits into the stiles.

**ALUMINUM CHANNEL.** Next, to guide the T-square, I added the aluminum channel to the *left* stile. It fits in a groove in the stile and is screwed in place, see Fig. 3a.

**PENCIL STOP.** Finally, to keep pencils from rolling off the table, I glued a *pencil stop* (N) to the bottom rail, see Fig. 3b.

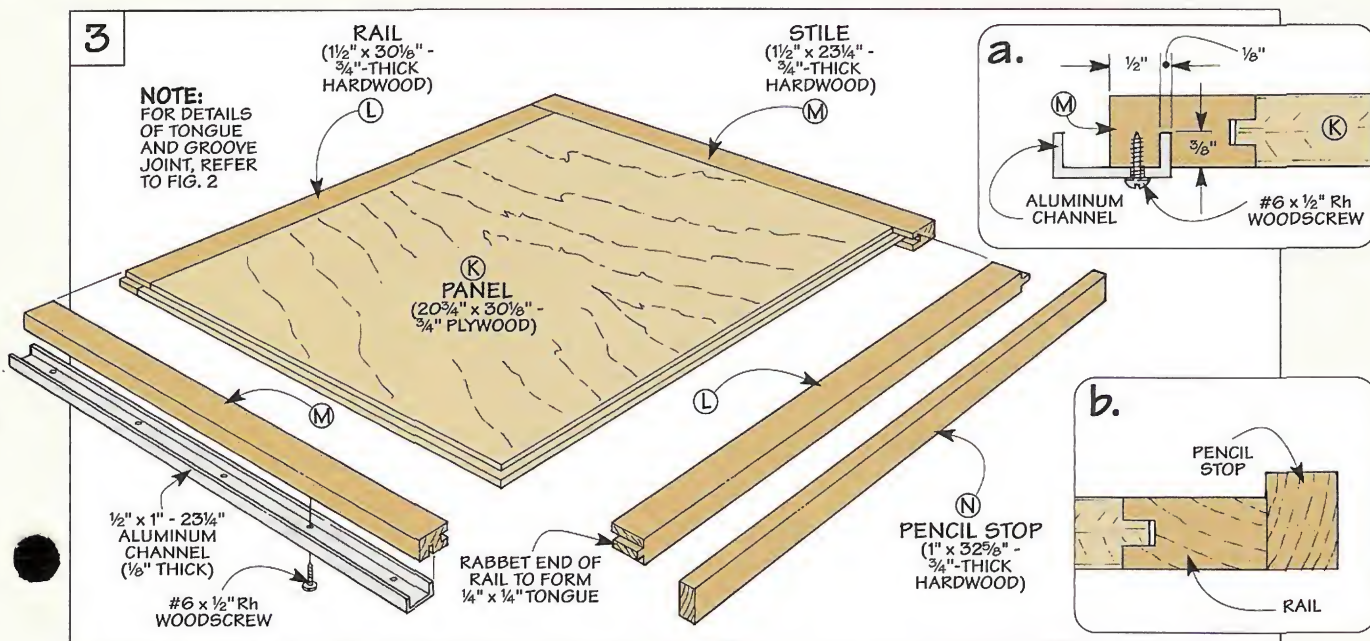

# Pivot System

The heart of the drafting table is a simple pivot system. It lets you swing the table out of the case (or fold it up). And it provides solid support for the table when it's open.

To make this work, the pivot system consists of two main parts: a pair of *supports* and two pivoting *arms*, see drawing at left.

**SUPPORTS.** The *supports* (O) are narrow pieces of hardwood attached to the bottom of the table, refer to Fig. 4 on next page. Two holes in the sides of each support are used to connect it to the case and the arm.

To provide clearance as the table folds up and down, you'll also need to cut a radius on the outside corner of each end of the supports. Then just glue and screw the supports in place.

**ARMS.** Next, I added the two *arms* (P), see Fig. 5. The arms pivot at each end. So you'll need

to drill a hole in each place for a bolt that acts as a pivot pin, see Fig. 5a. Here again, cutting a radius on *both* corners of the upper end only provides clearance as the arms pivot.

**ATTACH ARMS.** Now you can attach the arms. This is easy for the upper (curved) end of each arm. It's fastened to the support with a carriage bolt and lock nut.

But there's a bit more involved when it comes to the *lower* ends of the arms. That's because they're attached to the *lower panel* that was made earlier.

To create a uniform  $\frac{1}{8}$ " gap between this panel and the table, I slipped  $\frac{1}{8}$ " hardboard shims between the two parts. Also, placing scraps of  $\frac{1}{4}$ " hardboard under the assembly keeps it level and "snugs" the lower panel against the arms as they're screwed together.

**MOUNTING BLOCKS.** The next step is to add two hardwood *mounting blocks* (Q), see Fig. 5. These blocks are attached to the

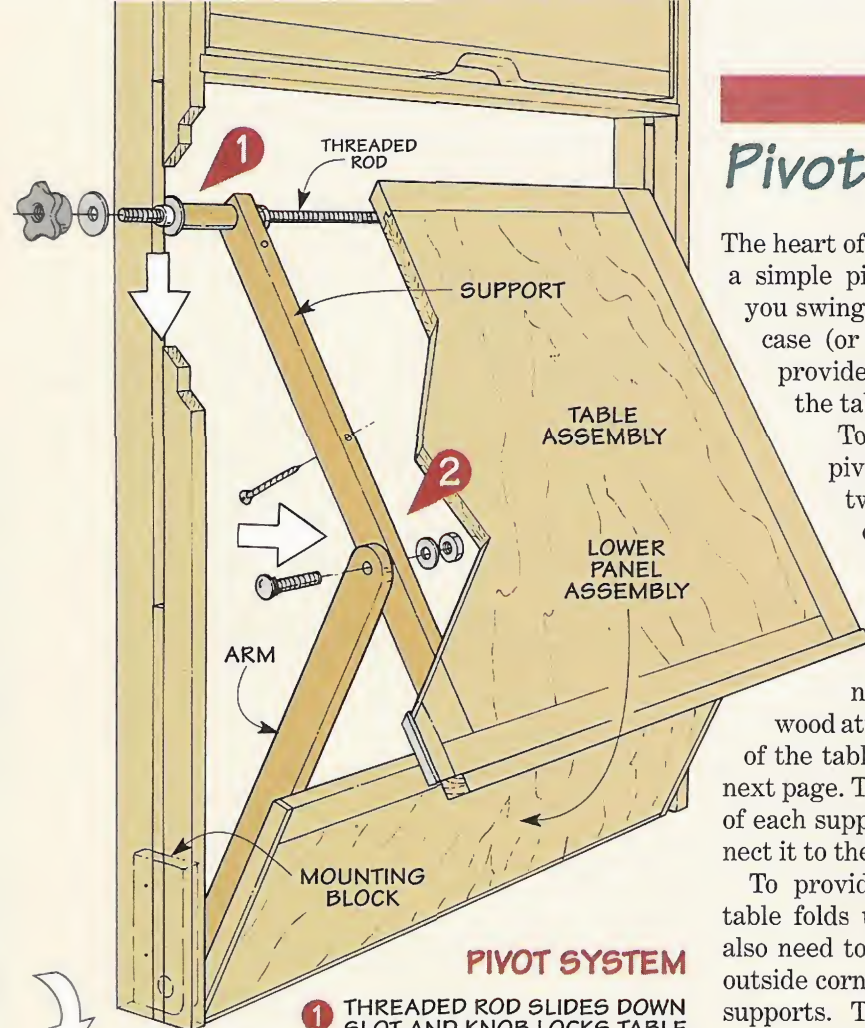

## PIVOT SYSTEM

- 1 THREADED ROD SLIDES DOWN SLOT AND KNOB LOCKS TABLE
- 2 SUPPORT PIVOTS ON ARM TO EXTEND TABLE OUTWARD
- 3 ARM FOLDS DOWN TO PROVIDE SOLID SUPPORT FOR TABLE

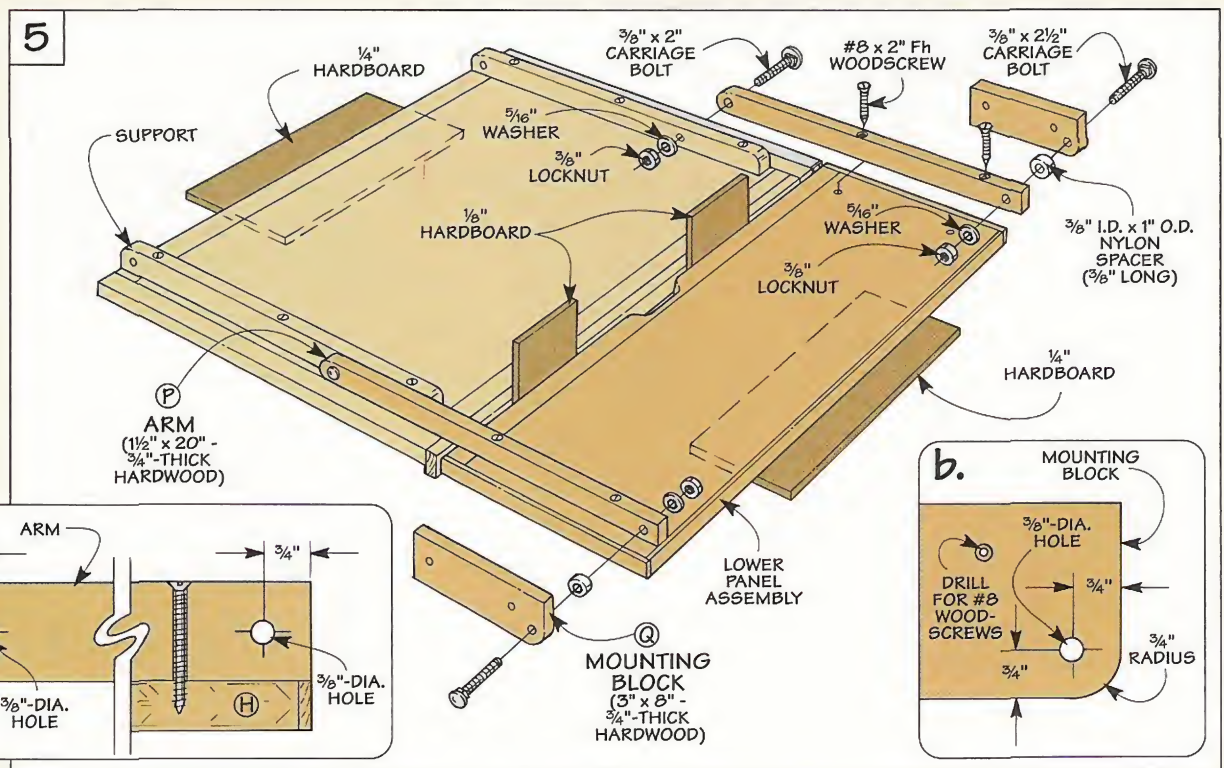

the arms first. Later, they're used to connect the arms to the case.

To prevent the lower panel from binding against the mounting blocks, you'll need to cut a radius on the lower inside corner of each block, see Fig. 5b.

As before, the mounting blocks are attached to the arms with carriage bolts and lock nuts. But this time, I slipped a  $\frac{3}{8}$ "-long nylon spacer in between. The space that this creates will allow the mounting blocks to fit tight against the sides of the case.

**FINAL ASSEMBLY**

At this point, it's just a matter of making a few final connections.

**THREADED ROD.** To "tie" the supports to the case, I used a long piece of threaded rod. It passes through the slots in the sides of the case and the holes in the supports, see Fig. 6.

As you open and close the table, the rod travels up and down the slots in the sides. A nylon spacer that fits on each end of the rod guides it smoothly up and down (and keeps the threads

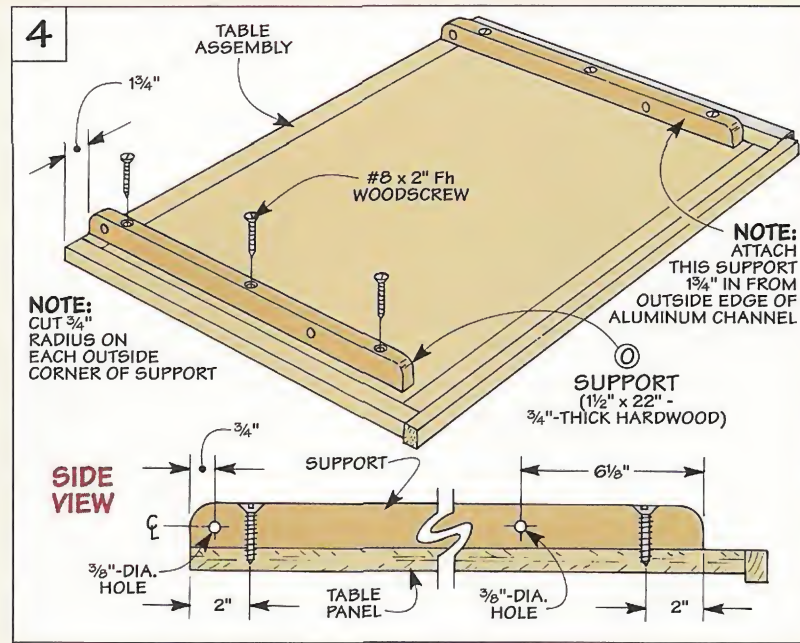

from chewing up the slots).

To prevent the table from racking, I also slipped a *guide* (R) between each support and the side. It's just a dowel with a hole drilled through the ends to fit over the rod, see page 14.

Finally, to keep the rod from moving from side to side, two "jam" nuts are tightened against

the *inside* face of each support. I also added a knob to each end of the rod to lock the table in place.

**MOUNT ARMS.** Now all that's left is to mount the arms. Here again, it's a good idea to use  $\frac{1}{8}$ " shims to get everything aligned first. Then simply screw the mounting blocks (Q) flush with the back edge of the sides.

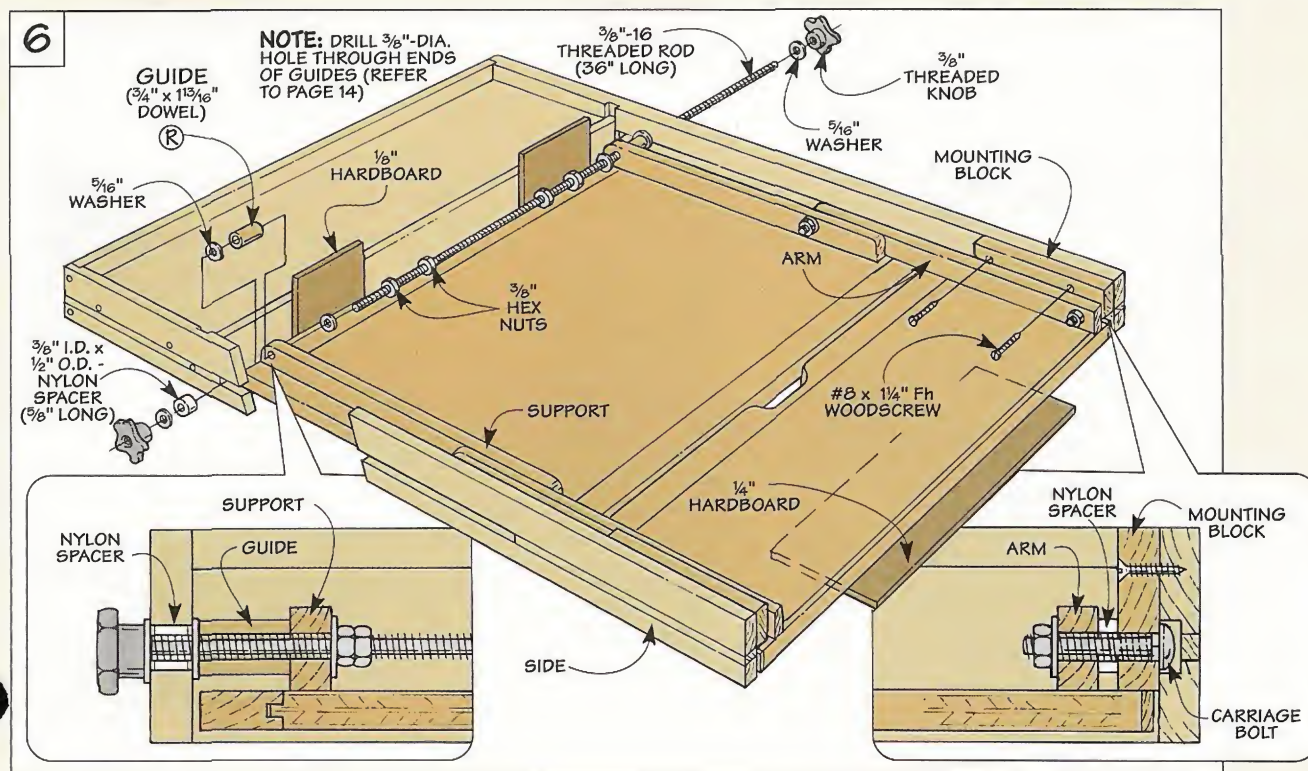

# Mounting System

Once the drafting table is assembled, it's just a matter of mounting it on the wall. It's held securely in place by two interlocking panels, see drawing at right.

**MOUNTING PANELS.** Both of these panels are made from 3/4" plywood. A *top mounting panel* (S) attaches to the back (G) of the case, see detail 'a.' And a *bottom mounting panel* (T) fastens to the wall, see detail 'b.'

One thing to note about the panels is there's a bevel on the edge where they come together. By orienting the bevels so the long tips point in opposite directions, the two panels "hook" together when you hang the case.

**BULLETIN BOARD.** But the bottom mounting panel is more than just a hanger — it also acts as a bulletin board. The bulletin board is built up from two layers: *foam board* on the bottom and *cork* on top, see Fig. 7 and margin.

One thing to be aware of is there's a strip near the top and bottom of the panel that's not covered. It keeps the screw holes from getting covered up. And it provides clearance for the shelf as you hang the case.

▲ The bulletin board is made up of two layers — foam board on the bottom and cork on top. Both are available at art supply stores.

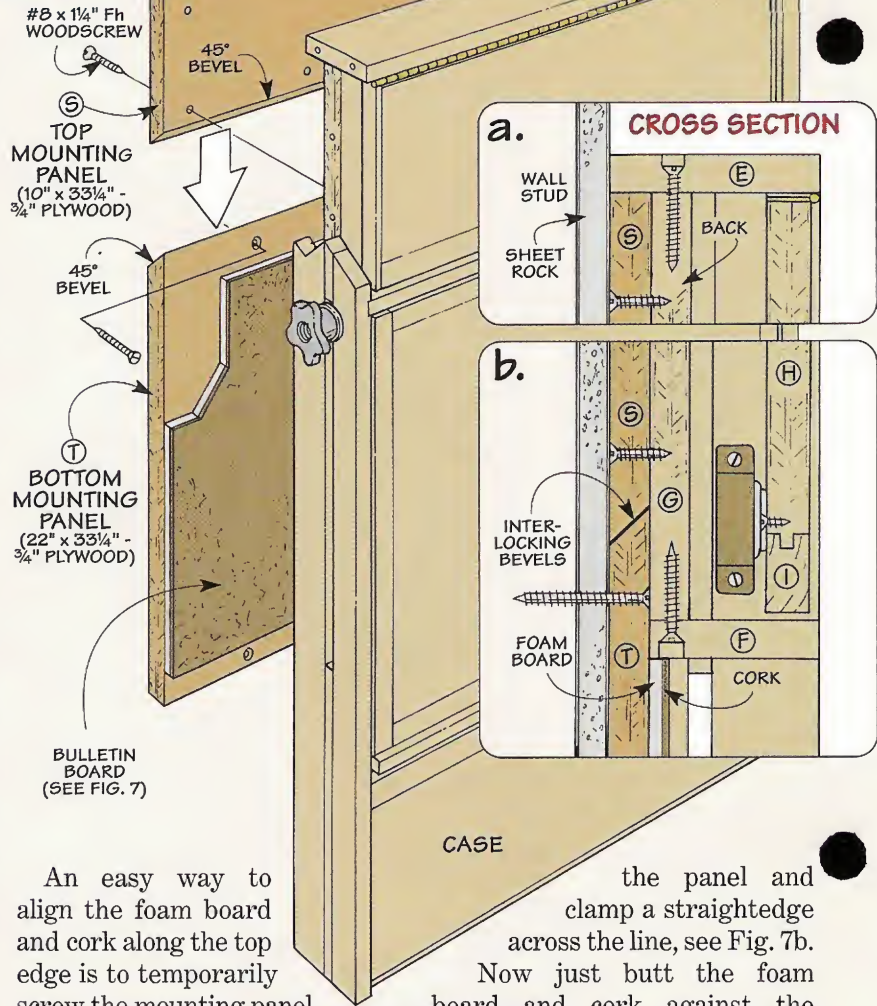

An easy way to align the foam board and cork along the top edge is to temporarily screw the mounting panel to the wall and mark a line under the shelf, see Fig. 7a. Then remove

the panel and clamp a straightedge across the line, see Fig. 7b. Now just butt the foam board and cork against the straightedge as you glue them in place. (I used white glue.)

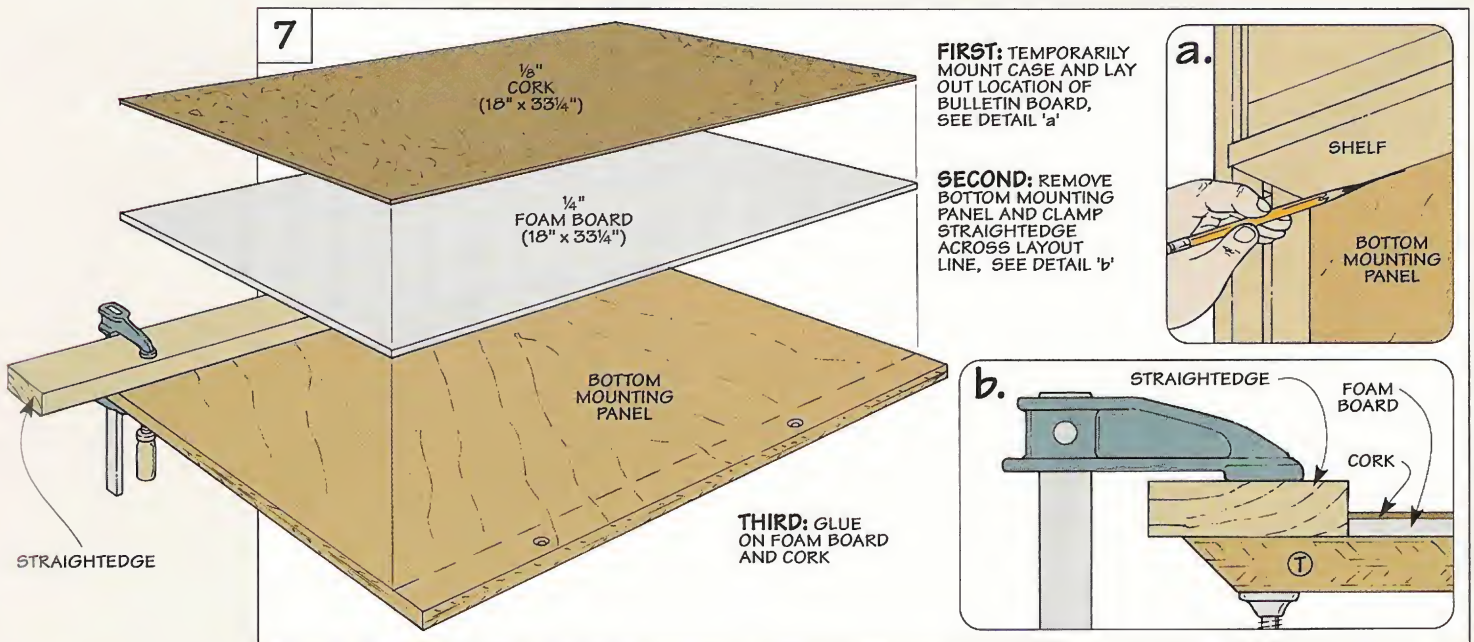

# T-Square

It's not a difficult thing to hold a T-square against the edge of a drafting table. It's just easier if you don't have to think about it.

That's why I like the T-square on this drafting table. It slides up and down on the aluminum channel which automatically holds it square to the table.

**GUIDE BLOCK.** The T-square starts off as a hardwood *guide block* (U), see Fig. 8. To keep the T-square aligned, a narrow groove in the guide block fits over the exposed leg of the aluminum channel, see Fig. 8a.

The goal here is to get the guide block to slide smoothly without any "play." I cut a single kerf and waxed the aluminum to get the guide block to glide smoothly on the channel.

**BLADE.** The next step is to add an L-shaped *blade*, see Fig. 8. It serves as the straightedge of the T-square. The blade is a piece of 1/4" Plexiglas that's cut and routed to shape, refer to page 15.

Note: The orange Plexiglas we used makes it easier to see pencil lines underneath. We purchased ours from a local plastic manufacturing company.

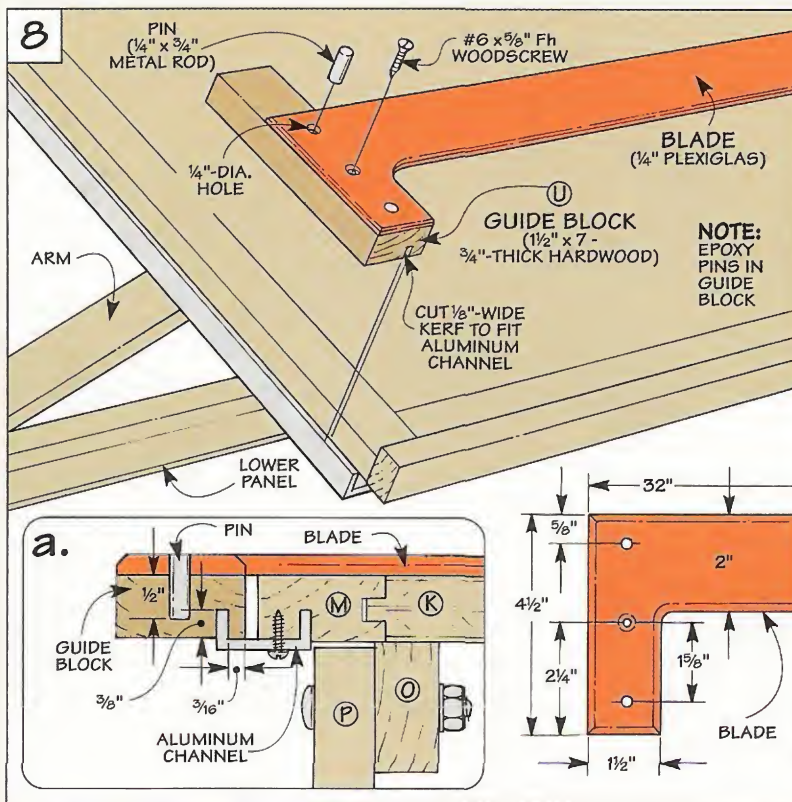

▲ Strips of carpet tape are all that's needed to attach the Borco cover to the table.

**ATTACH BLADE.** Now it's just a matter of attaching the blade to the guide block. It's held in place with two metal pins and a screw. The pins ensure that the blade remains square to the guide block. And the screw keeps the

blade from coming off the pins. **HOLDERS & COVER.** Finally, I made several holders for my drafting tools, see photos below. And I added a vinyl cover to the table to create a smooth drawing surface, see margin. 🐶



▲ The plastic back of a brush rests in a rabbeted block that's screwed to the back of the case.



◀ To hold the T-square, the blade is supported at each end by a thick block of hardwood with a kerf in it.

A scooped out block acts as a pencil tray. Setting the block in from the back lets you slip triangles behind it.



▲ An ordinary dowel with a kerf cut in one end provides a simple hanger for a compass.





*It only takes a few hours to make this scratch stock. But the decorative details it adds to a project will attract attention for generations.*

## Scratch Stock

**W**hen it comes to a classic old piece of furniture, it's the details that set it apart — a delicate bead, a shallow flute, or maybe just a shadow line formed by a V-shaped groove.

These details were often produced by a hand tool called a *scratch stock*. Typically, this was a wood-bodied tool with a metal cutter that was filed to the desired profile. By pushing (or pulling) the tool across the workpiece, the cutter “scratched” the detail into the surface.

As you can imagine, making a decorative detail like this required some elbow grease. (You wouldn't want to make *all* the molding for your house with a scratch stock.) Nevertheless, it was a perfect way to add a special touch to a small project.

To make it easy to produce this type of detail, I decided to make my own scratch stock, see photo above. Like an old-fashioned scratch stock, it provides a way to create a unique, decorative detail. But it uses a slightly unorthodox approach.

**WOOD & ALUMINUM.** The unusual thing is this scratch stock combines the look and feel of a traditional, wood-bodied tool with a modern twist — an aluminum sole plate. (I used an ordinary piece of aluminum angle.) It provides a simple, straightforward way to attach the fence of the scratch stock, see Exploded View on page 25. And it provides a stable base as you make a cut.

**CUTTER.** But before making any shavings, you'll need to have a cutter. Basically, it's just a piece of metal that's filed to the desired profile. We made our cutters from rectangular metal blanks that are already cut to size, see photo at left. But you could also use an old scraper or hacksaw blade. (For sources of pre-cut metal blanks, refer to page 31.)

**USES.** As simple as they are, these cutters can produce an amazing variety of decorative details, see photos on page 25. In fact, you'll find that some of these details are difficult (or even impossible) to produce with a standard router bit.



EXPLODED VIEW

Hardware

- (1) 2" x 2" - 4 1/2" Aluminum Angle (1/8" Thick)
- (3) 8-32 x 1" Brass Machine Screws
- (3) 8-32 Brass Knurled Nuts
- (3) 8-32 Brass Washers
- (2) #6 x 1/2" Brass-Plated Fh Woodscrews

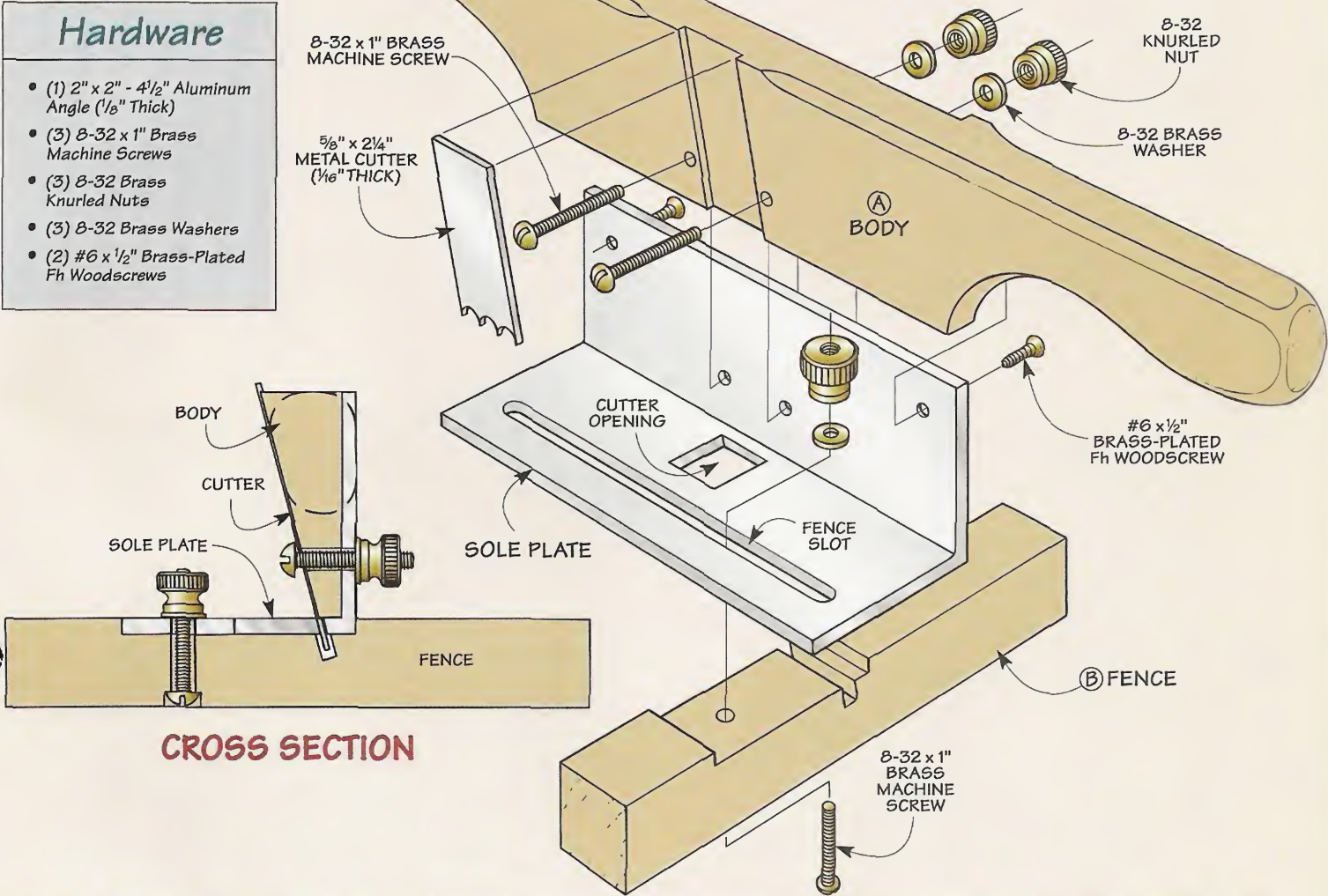

CROSS SECTION

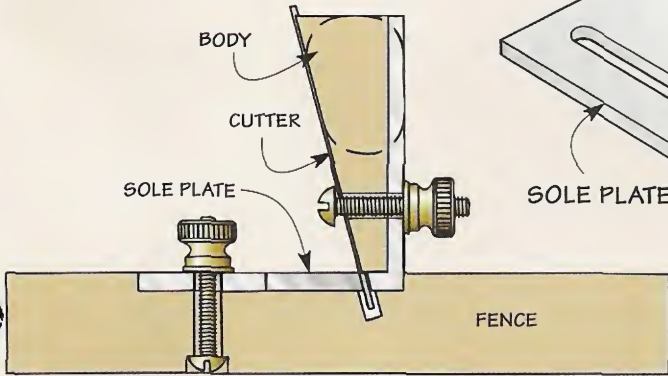

**Beads.** The beads on this drawer front were shaped with a single cutter — yet they can't be duplicated with a router bit.



**Repair.** To repair a piece of furniture, just file a cutter to produce a detail that matches the one on the damaged part.



**Multiples.** By using several cutters, you can produce a complex molding like the one on this picture frame.

# Body & Sole

I began work on the scratch stock by making two of the main parts: a hardwood *body* and a *sole plate* made from a piece of aluminum angle, see drawing.

## BODY

The body of the scratch stock serves two purposes. First, it holds the cutter in place. And second, it provides a firm, comfortable grip by incorporating two curved handles.

**BLANK.** The *body* (A) starts out as a single blank of  $\frac{3}{4}$ "-thick hardwood, see Fig. 1. Although any hardwood would work, it's a perfect opportunity to use a small piece of highly figured hardwood you've been saving for a special project. (I used bird's-eye maple.)

**WEDGE.** Regardless of the type of wood, the body is shaped like a wedge. The reason for this is simple. In use, the cutter is held against the *angled* side of the body. This orients the cutting edge at an angle to the workpiece. As a result, the cutter peels off shavings instead of scraping dust.

All it takes to form the wedge-shaped body is to rip a bevel down the length of the blank. I set the blade on my table saw to  $15^\circ$  and made a single pass over the saw blade, see Figs. 1 and 1a.

**PATTERN.** After cutting the wedge, the next step is to attach a pattern that shows the basic shape of the body, see Pattern on page 27. It's simply spray-mounted to the angled side of the wedge.

**CUT DADOES.** With the pattern in place, you'll need to cut two dadoes, see Fig. 2. A narrow dado on the angled side holds the cutter. And a wide dado on the opposite side accepts the aluminum sole plate, see Fig. 2a.

Note: To ensure a good fit, it's best to have the cutter in hand. I

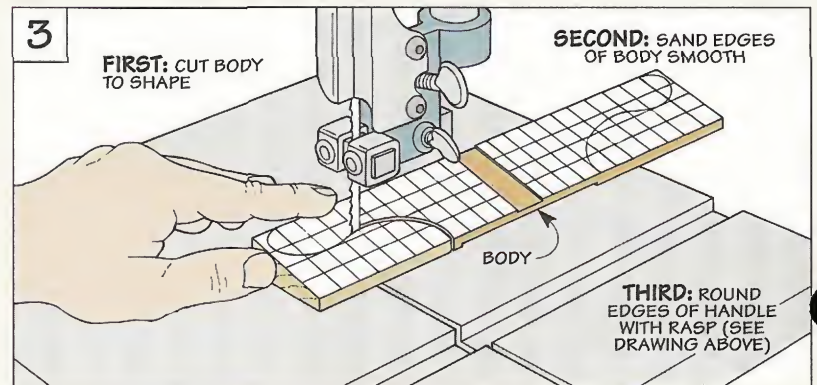
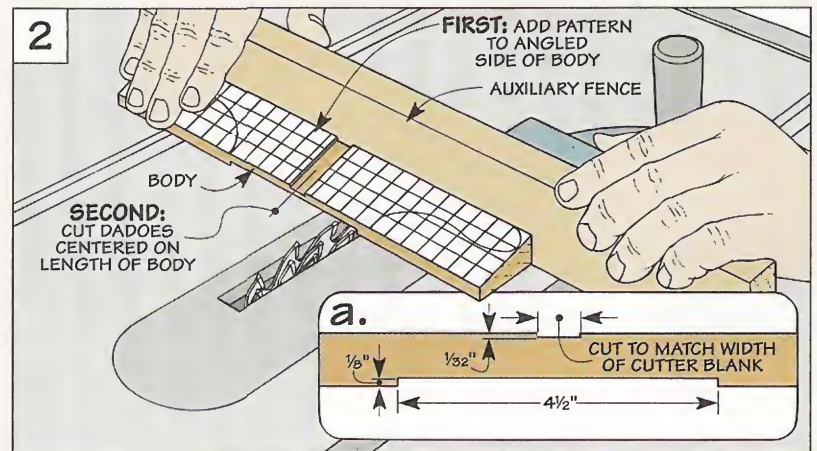
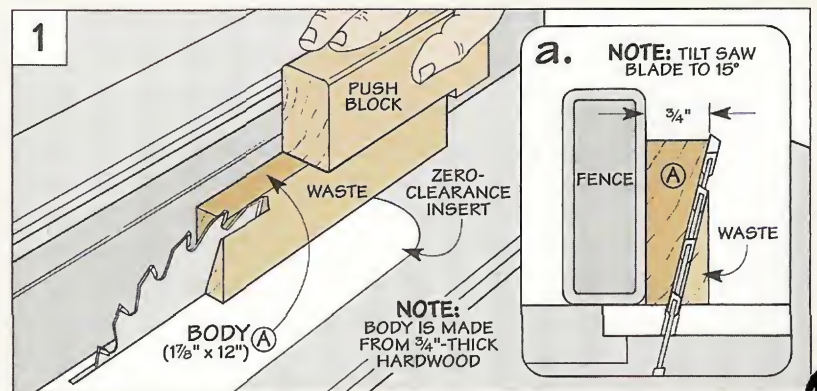
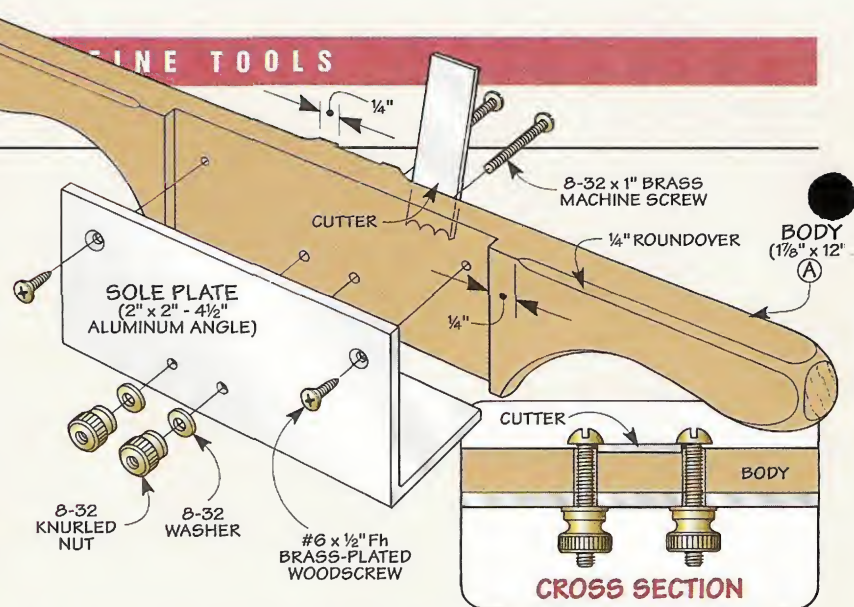

also cut the piece of aluminum angle to length that I planned to use for the sole plate.

Besides the different widths, the dados also vary in depth. To allow the sole plate to sit flush with the body, the depth of the wide dado matches the thickness of the aluminum angle ( $\frac{1}{8}$ " ), see Fig. 2a.

But with the narrow dado, the idea is to cut it to depth so it's *half* the thickness of the cutter ( $\frac{1}{32}$ " in my case). This means that the cutter will sit just a bit proud. As a result, when you tighten a machine screw (added later), it holds the cutter in place, see Cross Section on page 26.

**ROUGH SHAPE.** After completing the dados, the next step is to cut the body to rough shape. I used a band saw to cut the sweeping curves that form the handles, see Fig. 3. And a drum sander chucked in a drill press makes quick work of sanding the edges smooth.

**FINAL SHAPING.** Although the edges are smooth, the corners of the body are still too sharp to provide a comfortable grip. So I rounded the edges with a rasp. Note: I "stopped" the roundover  $\frac{1}{4}$ " from the shoulders of each dado, see drawing on page 26.

**SOLE PLATE**

With the body complete, you can turn your attention to the sole plate. It forms a stable base to prevent the scratch stock from rocking. And it provides a way to attach the fence.

**ALUMINUM ANGLE.** The sole plate is already cut to length. (It's the piece of aluminum angle that was cut earlier.) But to make the fence adjustable, you'll

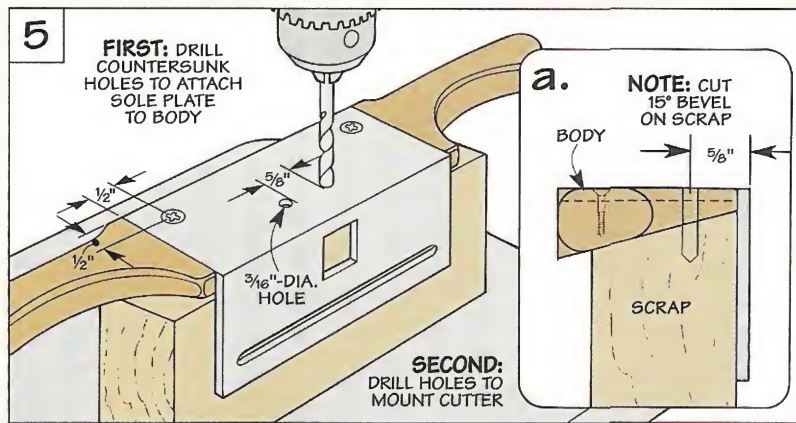
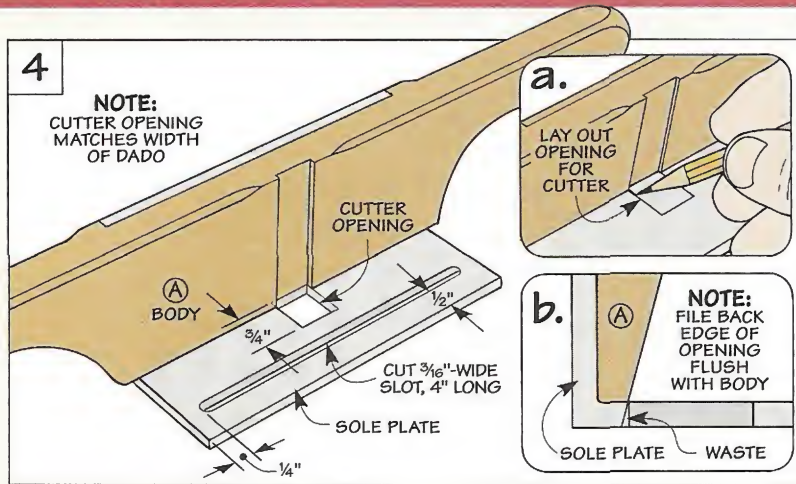

need to cut a long slot near the outside edge, see Fig. 4. There's also a rectangular opening near the inside corner of the angle that allows the cutter to stick down through the sole plate.

To ensure that the cutter aligns with this opening, I temporarily assembled the body and the sole plate. Then I marked the location of the opening, see Fig. 4a.

Now it's just a matter of cutting the opening and the slot, refer to page 15. After filing the edges smooth, there's one more thing to do. That's to file a slight ( $15^\circ$ ) angle on the inside edge of the rectangular opening, see Fig. 4b. This will allow the cutter

to sit flat against the body.

**ATTACH SOLE PLATE.** Now you're ready to attach the sole plate. This requires drilling two countersunk holes through the sole plate and screwing it to the body of the scratch stock.

**INSTALL CUTTER.** All that's left to do is install the cutter. It's held in place by two machine screws and a pair of knurled nuts, see Cross Section on page 26.

The only problem is drilling the holes for the screws in the angled body can be tricky. So to provide support as I drilled the holes, I beveled the edge of a scrap "two-by" to  $15^\circ$  to match the angle of the body, see Figs. 5 and 5a.

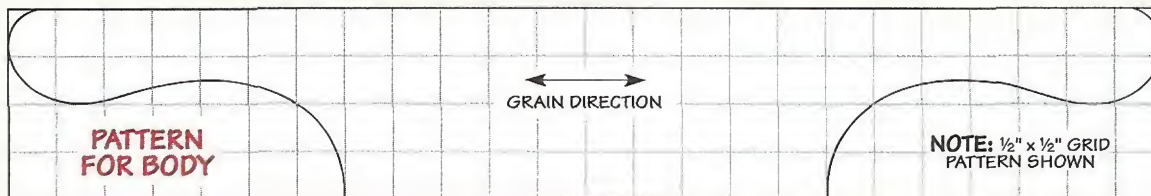

◀ **Pattern.** To create a full-size pattern of the body, enlarge the pattern at left 200% on a photo copy machine.

## The Fence

At this point, the scratch stock is almost complete. All you need is a fence to guide it as you make a cut.

**FENCE.** The fence (B) is nothing more than a short strip of hardwood that attaches to the sole plate, see drawing. By sliding the fence along the sole plate, you can adjust the distance of the cutter from the edge of the workpiece.

To ensure an accurate cut, the fence has to remain square to the cutter as it slides back and forth. That's accomplished by cutting a dado in the top edge to accept the sole plate, see Side View.

**KERF.** In addition to the dado, there's also an angled kerf cut in the fence. The kerf lets you "bury" part of the cutter, see margin. By using only a small portion of the cutter, you can work right up to the edge of a workpiece.

**SECOND:**  
LOCATE AND  
CENTER 1/8"-WIDE  
KERF UNDER  
CUTTER

**FENCE**  
(3/4" x 5" -  
3/4"-THICK  
HARDWOOD)

**FIRST:**  
CUT 1/8"-DEEP  
DADO TO FIT  
SOLE PLATE

**SIDE  
VIEW**

**SAFETY NOTE:**  
MAKE FENCE FROM  
EXTRA-LONG WORKPIECE

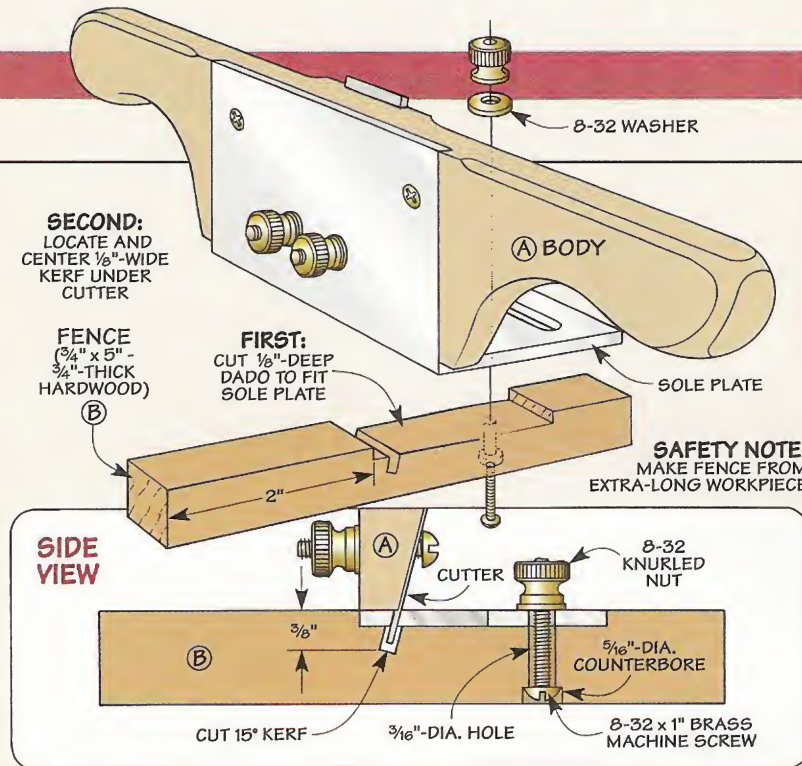

**ATTACH FENCE.** After cutting the kerf, the last thing to do is attach the fence. It's held in place with a machine screw and knurled nut. The machine screw

passes through a counterbored hole in the bottom of the fence and the slot in the sole plate, see Side View. Tightening the nut locks the fence in place.



To cut right to the edge of a workpiece, an angled kerf in the fence allows you to "bury" the cutter.

## "Aging" Bird's-Eye Maple

Since the design of the scratch stock is based on a traditional tool, I wanted it to have the soft look and feel that comes with use and time. But I didn't want to wait half a century to get it. So to speed things up, I used a special finishing technique.

**DARK EYES.** It starts by darkening the "bird's-eyes" of the maple. To do this, I brushed on a coat of aniline dye, see Step 1. (I used a honey amber maple dye.)

**SAND & SHELLAC.** But I didn't want that color across the entire surface. So I sanded the body until the dye remained only in the eyes, see Step 2. Then I applied a few coats of shellac to produce a nice, warm color, see Step 3.

**STEEL WOOL.** Finally, to give the body the soft patina of a well-worn tool, I buffed the finish with fine (4/0) steel wool, see Step 4.



**1** After dampening the wood to raise the grain, sand off the "whiskers" and apply a coat of aniline dye.



**2** Once the dye dries, sand the body until the color remains only in the "eyes." (I used 220-grit sandpaper.)



**3** To produce a warm, amber color, brush on several coats of orange shellac, sanding lightly between coats.



**4** After the last coat of shellac, buff the finish with fine steel wool (4/0) to bring out a nice, soft sheen.

## Making the Cutters



It only takes a few minutes to make a cutter for the scratch stock. All you need is a file and a metal blank, see page 31 for sources. Note: To make two cutters from one blank, just file each end, see photo.

**PATTERN.** The first step is to simply draw a pattern of the profile on the blank. (I used a permanent marker.) The thing to keep in mind here is the pattern is the *opposite* of the shape you want. To make a *bead* for example, draw a *cove* on the blank.

**FILING.** Once the pattern is marked, you're ready to file the cutter to shape. To prevent it from chattering, start by placing the cutter between a couple of scraps

tightened in a vise, see Fig. 6. Then take a number of smooth, straight strokes across the end of the cutter. Remember, you don't have to worry about filing a bevel (the body of the scratch stock will automatically establish the angle of the cutter).

**REMOVE BURR.** Filing the cutter will leave a ragged burr on the back of the cutter which could end up producing a rough surface. So you'll want to remove the burr. To do this, just sand the face of the cutter on a flat surface, see Fig. 7.

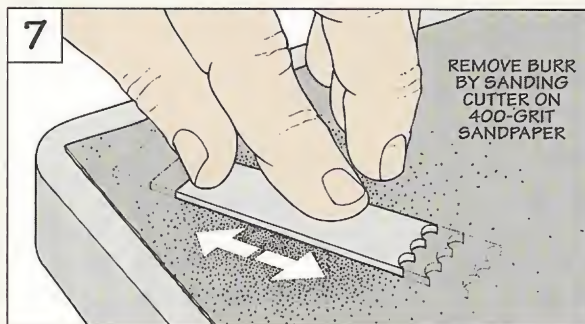
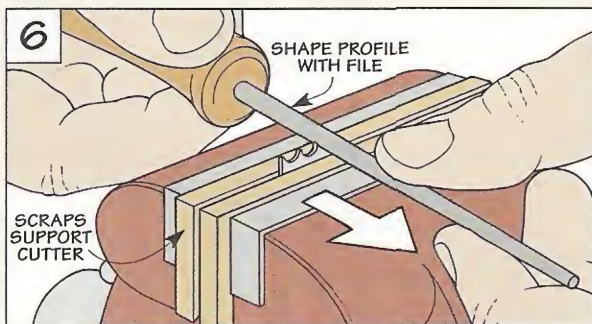

## Cutting a Profile

The secret to cutting a crisp, clean profile is to start with a *light* touch. In fact, the first pass barely scratches the surface, see photo A at right. Then you just make progressively deeper cuts (photo B) until the final profile is revealed, see photo C.

**SETUP.** It's this final profile that determines the initial setup of the scratch stock. Start by adjusting the depth of cut, see Step 1 below. Then simply position the fence, see Step 2.

**SCRAP PIECES.** Before cutting the profile on your project pieces, it's a good idea to practice on a scrap first. Once again, a light touch on the first pass will help establish the line of the cut. Then

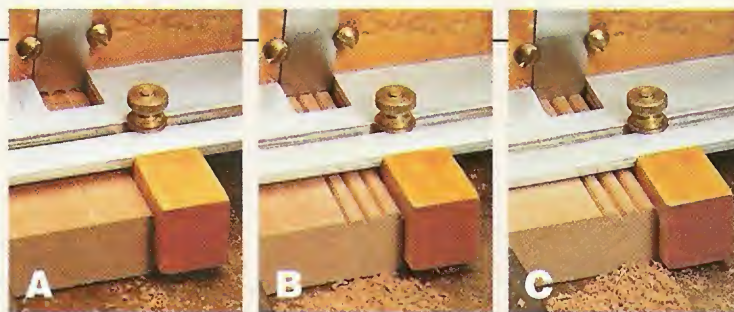

just make progressively deeper cuts, see Step 3.

**EXTRA-LONG PIECES.** Now it's time to cut the profile on the "real" piece. It's easiest to start with an extra-long piece. Once the profile is completed, cut as many pieces as needed to final length. 



**1** Start by adjusting the cutter for the desired depth of cut. Then tighten the knurled nuts to lock it in place.

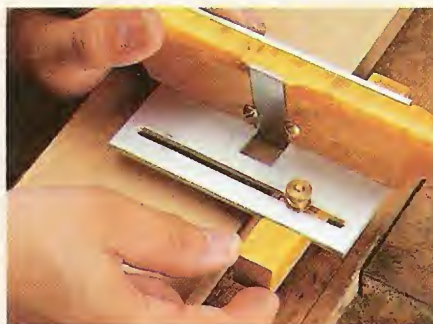

**2** Now position the fence to establish the distance that the cutter is set in from the edge of the workpiece.



**3** To cut the profile, hold the fence against the edge of the workpiece and pull the scratch stock toward you.

# Bird's-Eye Maple

*With its dramatic swirl marks, bird's-eye maple presents a special challenge to work with . . . and a satisfying reward.*

■ Recently, I was sorting through a stack of hard maple at the lumberyard. One of the boards I picked up was peppered with tiny swirl marks. Is this what's called bird's-eye maple? And why was it in the same stack as the rest of the maple?

Thomas Billings  
Lincoln, Nebraska

First of all, "bird's-eye" describes the *figure* in the wood — not the type of maple. The pattern of swirls that you're describing is found most often in hard maple. That explains why they both happened to be in the same stack of lumber.

Even so, I'd say you stumbled on a lucky "find." Usually, bird's-eye maple is sorted and sold separately. That's because the tiny "eyes" that give it its name are a real prize for many woodworkers.

When a finish is applied, these eyes appear to shimmer and take on a three-dimensional look. This dramatic figure can turn a fairly ordinary project into something special, see photo below.

## WORKABILITY

But the same thing that makes bird's-eye maple appealing to look at also makes it a challenge to work with. The biggest problem is the eyes have a frustrating tendency to chip out — especially if you run a board through the planer.

One way to get around this is to buy lumber that's close to the final thickness of the project. But if that's not possible, it's best to *sand* it to final thickness. I've had good luck renting time on a thickness sander at a local cabinet shop.

**JOINTING & ROUTING.** There are also some things you can do to prevent chipout when jointing or routing bird's-eye maple. As a rule, the lighter the pass, the better. I limit the depth of cut to  $\frac{1}{32}$ " and use a slow, deliberate feed rate.

**SCRAPING.** Finally, if you're working with bird's-eye maple, don't overlook an ordinary hand scraper. With a sharp burr, it will slice off thin, wispy shavings without causing tearout.

## FINISHING

After taking the time to get the surface of bird's-eye maple nice and smooth, you'll want to apply a finish that will make the eyes "pop."

**FILM FINISH.** One way to do this is to build up several layers of a film finish. This adds depth to the finish that makes the eyes look like tiny, sun-dappled raindrops on a window pane.

**ANILINE DYE.** To bring out this striking figure even more, I use a water-based aniline dye. Unlike a pigment stain that lies on the surface and obscures the grain, a dye penetrates the wood and highlights the eyes.

## AVAILABILITY

Although it's possible to find bird's-eye maple at the local lumberyard, you may have to order it by mail. Depending on the quality of the bird's-eye, expect to pay from \$5 to \$15 a board foot. Another alternative is to use bird's-eye *veneer*. It ranges in price from \$2 to \$8 a square foot. ▲



▲ The shimmering swirl marks and creamy white wood of bird's-eye maple make it a perfect choice when you're building that special project.

## Sources

- Black Mountain - Northwoods  
207-764-0301  
Lumber
- Groff & Groff  
Lumber  
800-342-0001  
Lumber
- Rare Earth  
Hardwoods  
800-968-0074  
Lumber
- Bri-Mar Industries  
800-377-6279  
Veneer
- Certainly Wood  
716-655-0206  
Veneer

# Sources

## PRODUCT INFORMATION



**ShopNotes Project Supplies** is offering some of the hardware and supplies needed to build the projects in this issue. We've also put together a list of other mail-order sources that have similar hardware and supplies.

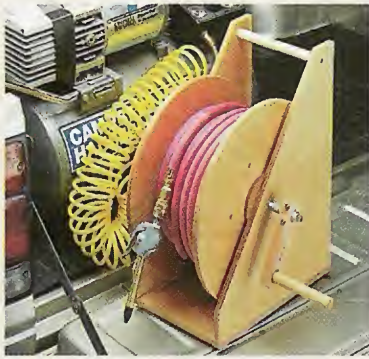

**▲ Portable Hose Reel**  
We're offering a hardware kit to build the Hose Reel (page 6). All you need to supply is the air hose, flexible air line, and the connectors used to hook up the flexible air line.

**HOSE REEL KIT**  
6841-100.....\$24.95

### Cutters for Scratch Stock ▶

To make the cutters for the Scratch Stock (page 24), it's just a matter of filing a profile in a metal blank. The blanks we used are available from the sources listed in the margin.

### Drafting Table ▶

The Fold-Down Drafting Table featured on page 16 provides a complete workstation for making your detailed shop drawings.

ShopNotes Project Supplies is offering a hardware kit to build the Drafting Table. All you need to supply are the foam board and cork for the bulletin board, a Borco cover for the table, and Plexiglas for the T-square.

**DRAFTING TABLE KIT**  
6841-200.....\$23.95



### Borco Cover for Drafting Table ▶

To provide a smooth drawing surface for the Drafting Table (page 16), we used a vinyl board cover. (Borco is one brand of material.) It cuts easily with a utility knife. But before you cut it to final size, it's a good idea to unroll it and let it "relax" for a couple of days. This way, it won't pull away from the edges of the table once it's laid down. Borco is available at many art supply stores.



### Selected Guide to the Best Projects from ShopNotes

These simple, shop-made planes are as practical as they are handsome. A complete hardware kit with everything you need to build each plane is still available.



**▲ Hand Plane**  
A straightforward design makes this Hand Plane easy to build. And an extra-thick blade and matching chipbreaker help reduce chipout. A complete hardware kit (with plans provided in ShopNotes No. 11) is available to build this Hand Plane.

**HAND PLANE KIT**  
6811-125.....\$26.50



**▲ Chisel Plane**  
Since the blade extends in front of the body, this Chisel Plane is a perfect tool to clean up hard to reach places. We're offering a complete hardware kit to build the Chisel Plane. ShopNotes No. 14 is also included to provide step-by-step instructions.

**CHISEL PLANE KIT**  
6814-225.....\$27.95



**▲ Scraper Plane**  
This Scraper Plane uses an ordinary hand scraper to produce a nice, smooth surface — without wearing out your thumbs. A hardware kit (with plans provided in ShopNotes No. 27) is available to build this scraper plane.

**SCRAPER PLANE KIT**  
6827-125.....\$19.95

## MAIL ORDER SOURCES

**Garrett Wade**  
800-221-2942  
Blanks for Cutters

**Woodcraft**  
800-225-1153  
Blanks for Cutters

**The Art Store**  
800-652-2225  
Borco Covering

TO PLACE AN ORDER CALL  
**800-347-5105**  
(KEY CODE: SN 41)

## Scenes from the Shop

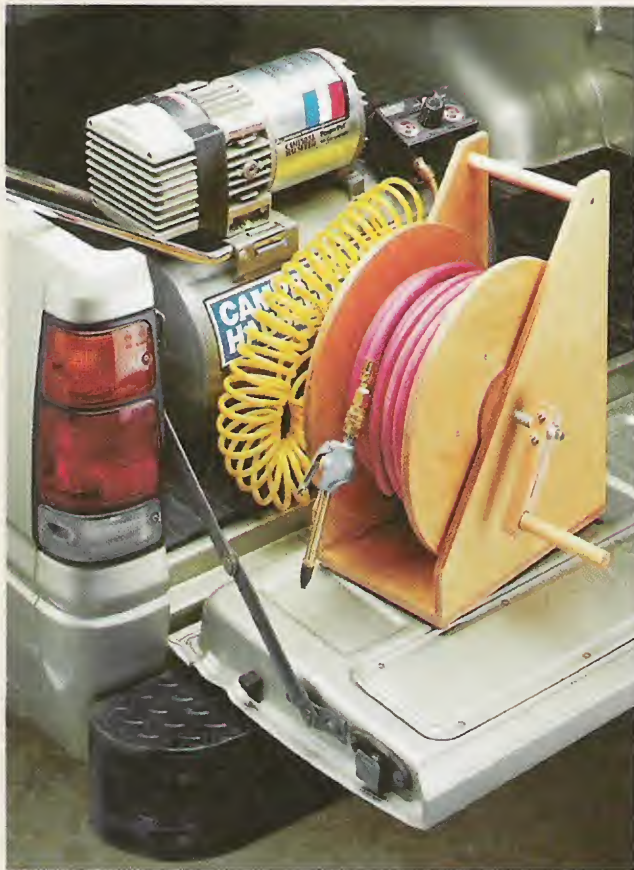

▲ **Portable Hose Reel.** Helping a friend with a job? Just take your air compressor and this shop-built hose reel with you. (Step-by-step instructions begin on page 6.)

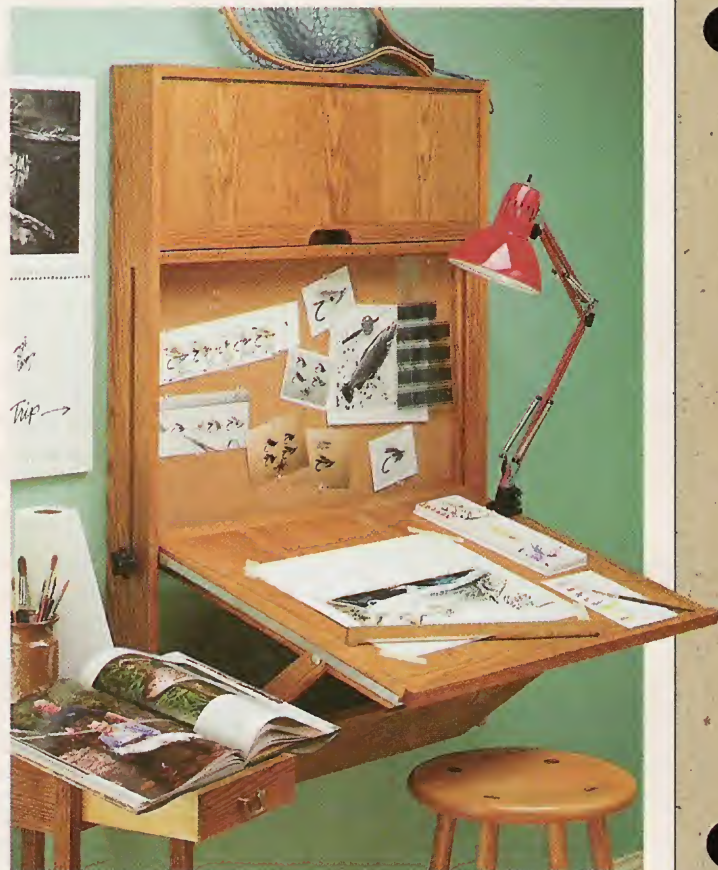

▲ **Drafting Table.** Hang this fold-down drafting table in a studio or the shop. Either way, its large table provides a handy work surface. (Our plans begin on page 16.)



▲ **Scratch Stock.** The inspiration for our scratch stock (background) came from this old Stanley No. 66 Hand Bearer (foreground). Each tool uses a metal cutter

that's filed to shape. With a fence riding against the edge of the work, the cutter "scratches" a decorative detail in the surface. (See page 24 for complete plans.)