

ShopNotes®

Vol. 8

Issue 46

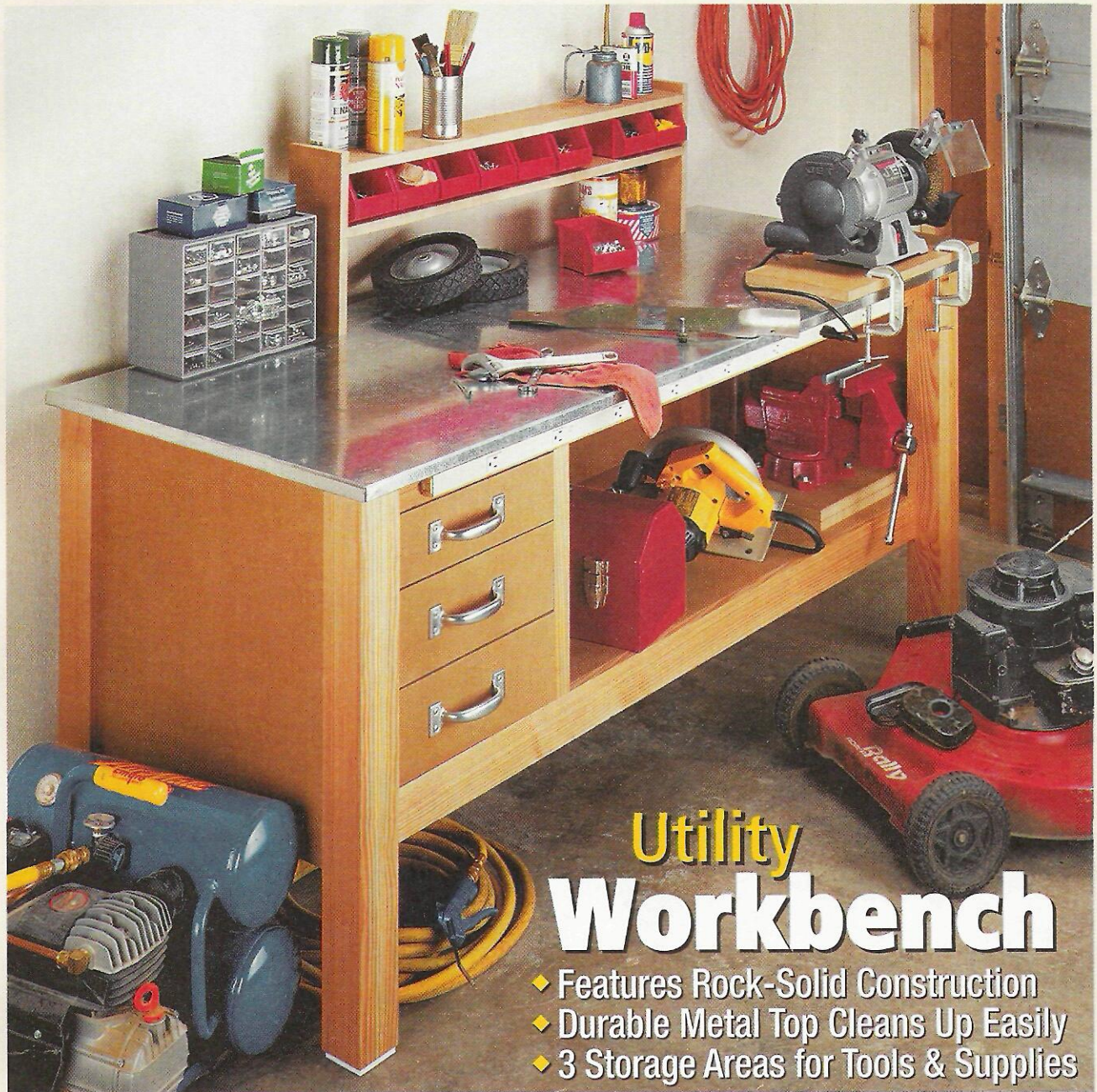

Utility Workbench

- ◆ Features Rock-Solid Construction
- ◆ Durable Metal Top Cleans Up Easily
- ◆ 3 Storage Areas for Tools & Supplies

- Adjustable Shop Stool
- Mobile Clamp Cart
- Cutting Threads in Wood
- Shop-Tested Tips



ShopNotes®

Issue 46

July 1999

PUBLISHER Donald B. Peschke
EDITOR Tim Robertson
ASSOCIATE EDITOR Tom Begnal
ASSISTANT EDITOR Bryan Nelson
ART DIRECTOR Cary Christensen
SR. GRAPHIC DESIGNER Kurt Schultz
SENIOR ILLUSTRATORS Roger Reiland
 Mark Higdon

CREATIVE RESOURCES

Creative Dir.: Ted Kralicek • *Project Developer:* Ken Munkel • *Sr. Project Designer:* Kevin Boyle • *Project Coordinator:* Kent Welsh • *Shop Mgr.:* Steve Curtis • *Shop Craftsman:* Steve Johnson • *Sr. Photographer:* Crayola England • *Photographer:* Roderick Kennedy

SPECIAL PUBLICATIONS

Executive Editor: Douglas L. Hicks • *Art Director:* Steve Lueder • *Sr. Graphic Designers:* Chris Glowacki, Cheryl L. Simpson • *Asst. Editors:* Joe Irwin, Craig Ruesgesser

CIRCULATION

Sub. Serv. Dir.: Sandy Baum • *New Bus. Dir.:* Glenda Battles • *Circ. Marketing Analyst:* Kris Schlemmer • *Creative Mgr.:* Melinda Haffner • *Renewal Mgr.:* Paige Rogers • *Billing Mgr.:* Rebecca Cunningham • *Prom. Mgr.:* Rick Junkins • *New Bus. Mgr.:* Todd L. Bierle • *Asst. Sub. Mgr.:* Joy Krause

CORPORATE SERVICES

Vice President of Planning & Finance: Jon Macarthy • *Controller:* Robin Hutchinson • *Sr. Accountant:* Laura Thomas • *Accounts Payable:* Mary Schultz • *Accounts Receivable:* Margo Petrus • *Prod. Dir.:* George Chmielarz • *Electronic Pub. Dir.:* Douglas M. Lidster • *Network Admin.:* Chris Schwanebeck • *Prod. Assistant:* Susan Rueve • *Pre-Press Image Specialist:* Troy Clark, Minnette Bieghler • *New Media Mgr.:* Gordon C. Gaippe • *Multimedia Art Dir.:* Eugene Pedersen • *E-Commerce Analyst:* Carol Schoeppler • *Web Site Editor:* Holly Kilborn • *Web Site Product Specialist:* Adam Best • *Human Resources Assistant:* Kirsten Koele • *Office Mgr.:* Julia Fish • *Receptionist:* Jeanne Johnson • *Building Maintenance:* Ken Griffith • *Special Projects Dir.:* Saville H. Inman • *Mail Room Clerk:* Lou Webber

MAIL ORDER

Operations Dir.: Bob Baker • *Cust. Serv. Mgr.:* Jennie Enos • *Warehouse Supr.:* Nancy Johnson • *Buyer:* Linda Jones • *Admin. Asst.:* Nancy Downey • *Tech. Rep.:* Matthew TeRonde • *Cust. Serv. Reps.:* Anna Cox, Tammy Truckenbrod, Deborah Rich, April Revell, David Gaumer • *Warehouse:* Sylvia Carey, Dan Spidle, Eric Tullis, Sheryl Knox

WOODSMITH STORE

Manager: Dave Larson • *Assistant Manager:* Paul Schneider • *Sales Staff:* Pat Lowry, Wendell Stone, Jim Barnett, Kathy Smith, Larry Morrison, Harold Cashman • *Office Manager:* Vicki Edwards

ShopNotes® (ISSN 1062-9696) is published bimonthly (Jan., March, May, July, Sept., Nov.) by August Home Publishing, 2200 Grand, Des Moines, IA 50312.

ShopNotes® is a registered trademark of August Home Publishing ©Copyright 1999 by August Home Publishing. All rights reserved.

Subscriptions: Single copy: \$4.99. One year subscription (6 issues), \$21.94. Canada/International add \$10 per year, U.S. funds.

Periodicals Postage Paid at Des Moines, IA and at additional mailing offices.

Postmaster: Send change of address to ShopNotes, P.O. Box 37103, Boone, IA 50037-2103.

Subscription Questions? Write to: ShopNotes Customer Service, P.O. Box 842, Des Moines, IA 50304-9961. Or call 1-800-333-5854, 8:00 am to 5:00 pm, Central Time, weekdays. FAX 515-283-0447

E-Mail: ShopNotes@shopnotes.com

Internet: http://www.shopnotes.com

PRINTED IN U.S.A.

EDITOR'S NOTE

Cutoffs

Recently, I was rummaging around a cardboard box at an auction. It was one of those "everything for a buck" boxes. The kind that's filled with old door knobs, balls of yarn, and cracked clay pots — all stuff I can live without.

I was about to give up when I came across something unusual. It was a thick, wood block with a handle on each end. In the middle of the block was a hole about the size of a quarter. As I peered into the hole, I could see a metal, V-shaped cutter sticking into the opening.

THREADBOX. That's when I realized just exactly what I'd found. It was an old-fashioned threadbox that had been used to cut threads in a wood dowel.

The idea was to fit the threadbox over the end of a dowel, grab the handles, and spin the box around. As the threadbox rotated around the dowel, the cutter sliced a spiral groove that formed the wood threads.

Although I knew the theory, I wasn't sure it would actually work. So I decided to buy the threadbox and give it a shot.

CUTTING THREADS. As it turns out, cutting threads was as easy as sharpening a pencil. Before I knew it, I'd threaded a two-foot long section of the dowel.

I have to admit, for my first try at cutting wood threads, I was impressed. It was an intriguing process that made me want to build a project that uses a threaded wood dowel.

MATCHING TAP. There was just one problem. To make the piece that the dowel threads into, I'd need to drill a hole and cut matching threads. This required a special cutter called a tap. Unfortunately, the matching tap for my

threadbox had long since disappeared.

But I wasn't out of luck. After checking around a bit, I found several woodworking catalogs that offered a threadbox and a tap as a matched set. So I bought a small set (one that's sized for 3/4" dowels) and used it to make a couple of simple things. They turned out so well, I decided to try my hand at something bigger.

ADJUSTABLE STOOL. It was the perfect opportunity to build a project I'd been wanting for a long time — an adjustable height shop stool. A large threaded dowel would be just the ticket

for raising and lowering the seat. (I wanted to use a 1 1/2"-dia. dowel.)

To accept that size dowel, I'd need a larger threadbox. In the process of looking around for

one, I came across a company that manufactures a jig which is used to cut threads with a router. So I decided to experiment with it as well. (For more on this, refer to page 15.)

After working with both types of threading tools, I learned a couple of things. First of all, to produce clean, crisp threads, the dowel you use is just as important as the tool. Second, regardless of the size of the dowel, the technique is basically the same. (We've included a number of tips on selecting dowels and cutting wood threads in the article beginning on page 12.)

As you can see, I'm pretty excited about cutting wood threads. If you've never done this, I'd recommend getting a threadbox and giving it a spin. But I have to warn you. It's a lot like eating popcorn — once you get started, it's hard to stop.

As the threadbox rotated around the dowel, the cutter sliced a spiral groove that formed perfect wood threads.

Tim

Contents

Features

Adjustable Shop Stool _____ 6

It's easy to adjust this shop stool to a comfortable working height — just give the seat a spin. The secret is a shop-made wood "screw" that threads into the base of the stool.

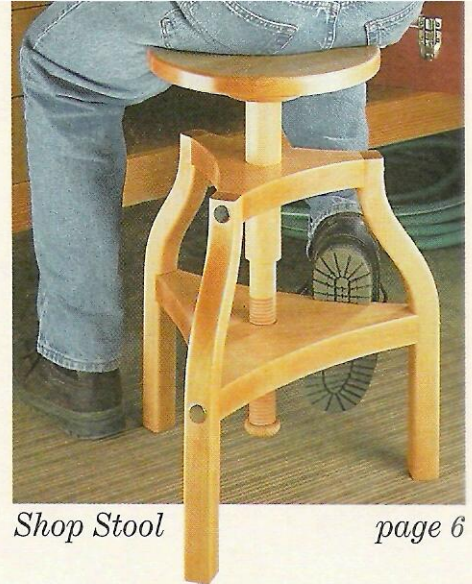

Shop Stool

page 6

Cutting Threads in Wood _____ 12

There's nothing mysterious about cutting threads in wood. We show you how to cut threads by hand. Or you can rout the threads instead.

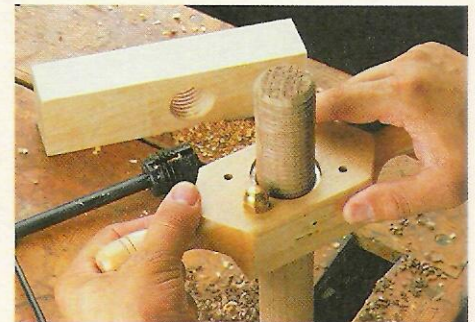

Cutting Threads

page 12

Utility Workbench _____ 16

This utility workbench is ideal for those tough, dirty jobs around the house. It has a durable metal top that cleans up quickly. And a solid base provides plenty of storage.

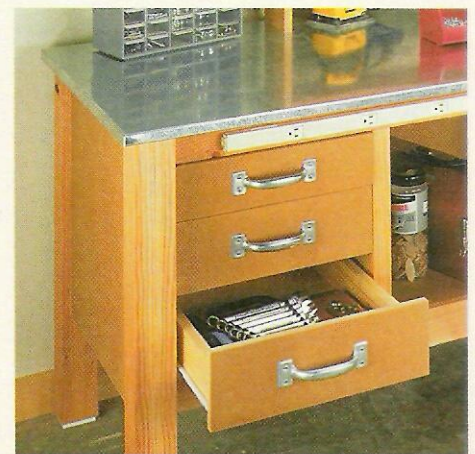

Utility Workbench

page 16

Roll-Around Clamp Cart _____ 24

Keep clamps and glue-up supplies handy with this roll-around cart. Custom-made hangers hold different types of clamps securely yet still provide quick, easy access.

Departments

Readers' Tips _____ 4

Our readers offer their own shop-tested tips dealing with some of the most common woodworking problems.

Shop Solutions _____ 28

Useful tips for building projects in this issue — how to rabbet long pieces, drill angled holes, and cut perfectly round disks.

Tool Talk _____ 30

Tips and talk about the tools of our trade. In this issue, we take a look at saw blade stabilizers and extension cords.

Sources _____ 31

Information and mail-order sources for the hardware and supplies used to build the projects in this issue.



Clamp Cart

page 24

Readers' Tips

Flip-Up Planer Stand

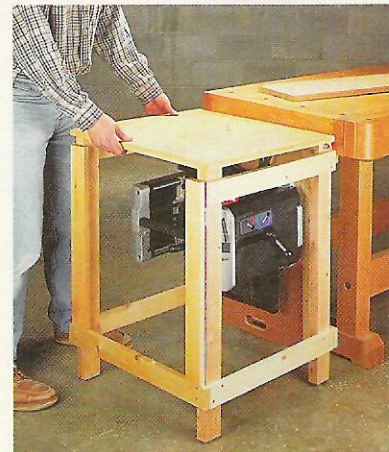
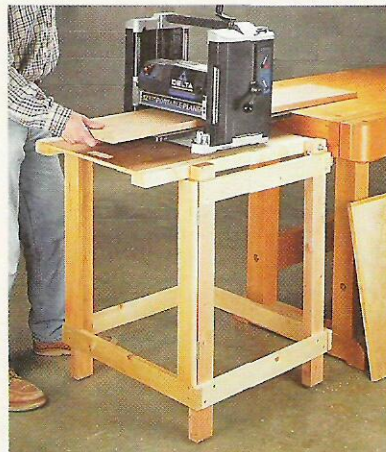
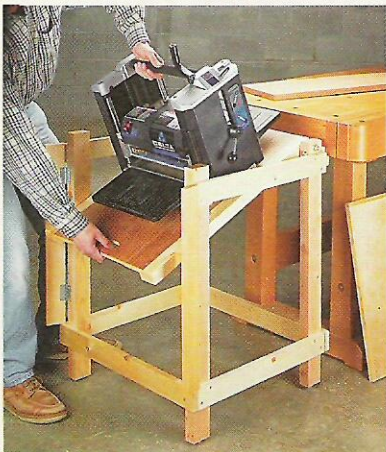

■ Lifting a heavy thickness planer onto my workbench always gives me a backache. So to make it easy to set up the planer (and avoid straining my back), I built a simple stand that attaches to my bench.

The unusual thing about this stand is the planer is mounted to a table that

swings up and down. To use the planer, I just flip up the table, see photo above left. In this position, the bench doubles as a long, outfeed support that reduces the snipe at the end of the board, see photo at center.

After completing a job, it only takes me a second to lower the table.

With the planer stored out of the way, I can slip a plywood top over the stand to use as an extra work surface, see photo at right.

LEGS & STRETCHERS. The stand starts out as four *legs* made of “two-by” material that are connected with $\frac{3}{4}$ ”-thick *stretchers*, see drawing below. To add rigidity to the stand, it’s best to glue *and* screw these stretchers to the legs. (I “wrapped” the bottom of the stand with four stretchers and added two at the top.)

TABLE. With the basic framework complete, the next step is to add the table. It consists of two *pivot arms* that are rabbeted to accept a $\frac{1}{2}$ ” plywood *top*. To create a pivot point for the table, a threaded rod passes through the two inside legs and the pivot arms. Tightening a lock nut on each end of the rod secures the table to the stand. And I added a pair of hinged *supports* to prop up the table in the raised position, see detail ‘b’.

ATTACH STAND TO BENCH. Now all that’s left is to attach the stand to the bench. This is just a matter of screwing a cleat to the bottom of the bench and securing the stand with lag screws, see detail ‘a.’

John E. Leigh
Chaska, Minnesota

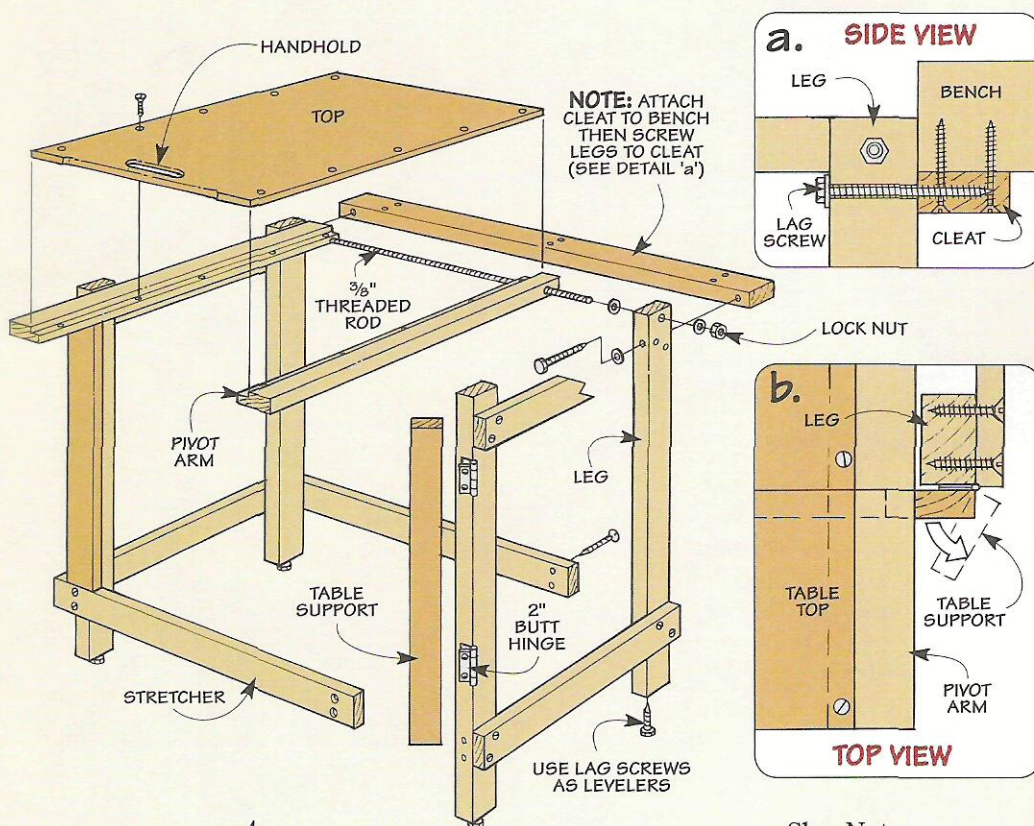

Quick Tips



▲ When working in tight places, **Bob Lee** of Miami, FL uses a simple trick to thread a nut on a bolt. He carpet-tapes the nut to his finger.



▲ It's easy for **Chris Glowacki** of West Des Moines, IA to tote boards from the lumberyard. He bundles them together with "cling wrap."

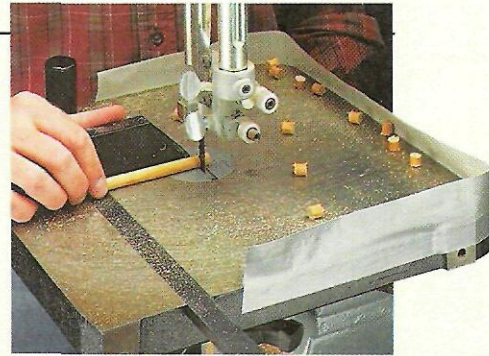

▲ To keep short dowel plugs from rolling off his band saw table, **Keith Mulford** of Arlington Hts., IL "corrals" them with a strip of duct tape.

Dust Pick-Up

■ Whenever I sand a workpiece on the lathe, my shop gets filled with a cloud of wood dust. To prevent this, I made a simple dust pick-up that holds the hose on my shop vacuum

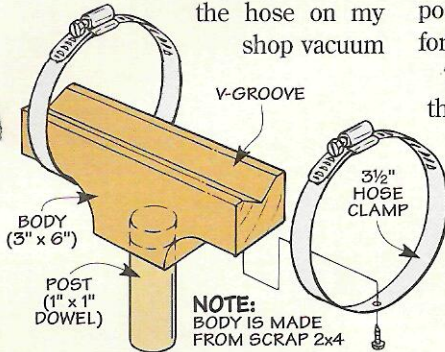

up close to the spinning workpiece, see photo at right.

Basically it consists of two parts: a body that supports the hose and a post (dowel) that fits into the casting for the tool rest, see drawing.

To quickly position the hose on the body, there's a V-shaped groove in the top edge. And the post is glued into a hole drilled in the bottom edge of the body.

The vacuum hose is held in place by a pair of automotive hose clamps that wrap around the curved ends of



the body. To keep the clamps from slipping off, I drilled a hole in each one and attached it with a screw.

*Jim Vasi
Williamsville, New York*

Caulking Tube Storage

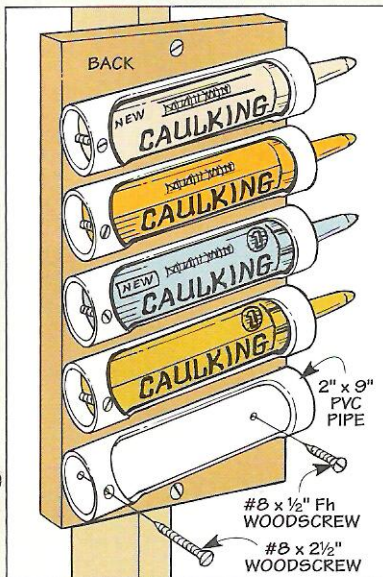

■ I usually have several tubes of caulking lying around the shop. But I can't always find the one I need.

To keep the caulking tubes handy, I made a simple storage rack. All it takes is a piece of plywood and some short lengths of PVC pipe. The plywood serves as a back. And the pieces of pipe act as storage compartments for the tubes, see drawing.

I cut a "window" in each piece of pipe. This lets me see the tube I need at a glance.

To make sure the tubes stay put, the pieces of pipe mount to the back at a slight angle. Two screws (a short one and a long one) secure each pipe to the back. The long

screw also keeps the caulking tube from falling out of the lower end of the pipe.

*Daniel L. O'Neal
Shrewsbury, Missouri*

Send in Your Shop Tips

To share your original shop tips to problems you've faced, send them to: *ShopNotes*, Attn.: Readers' Tips, 2200 Grand Avenue, Des Moines, IA 50312. (Or if it's easier, FAX them to us at: 515-282-6741.)

We'll pay up to \$200 depending on the published length. Please include a daytime phone number so we can call you if we have any questions.

Adjustable Height Shop Stool

Adjusting the height of this shop stool is a snap. Just give the seat a spin.

When it comes to finding a place in the shop that's at a comfortable working height, I often feel like Goldilocks looking for the perfect size chair. Depending on the project I'm working on, it's either too tall or too short. (Alright, sometimes it *does* happen to be just right.)

But more often than not, the table height is somewhere in between. That's why I built this shop stool. It has a threaded wood post that raises and lowers the seat like an old-fashioned piano stool. (The seat adjusts from 22¹/₂" to 29¹/₂".)

THREADED POST. So where do you get a post with *wood* threads? It's simple — you make it yourself. I

know, it sounds complicated. But it isn't much more difficult than sharpening a pencil. All it takes is a dowel and a simple thread-cutting jig. (For more information, refer to page 12.)

STABILITY. But the real test of a stool is if it's stable enough to keep from tipping when you sit down. To create a stable base, a stool needs to be wider at the bottom than the top. This usually requires a lot of fussing around with tricky angles. But with this stool, I avoided that altogether.

CURVED LEGS. The secret is a gentle, 'S-shaped' curve on each leg. The lower, vertical sections of the legs are joined to a thick, triangular support at right angles. Then the legs curve inward to meet a second (smaller) support — also at a 90° angle.

LEG BLANKS. Even though the legs are nicely curved, there's nothing delicate about them. They're made from thick hardwood blanks. (I used 1¹/₂"-thick maple.)

After cutting three blanks to final size, transfer the Leg Pattern (shown at left) to one of the blanks. It's also a good idea to lay out the location of

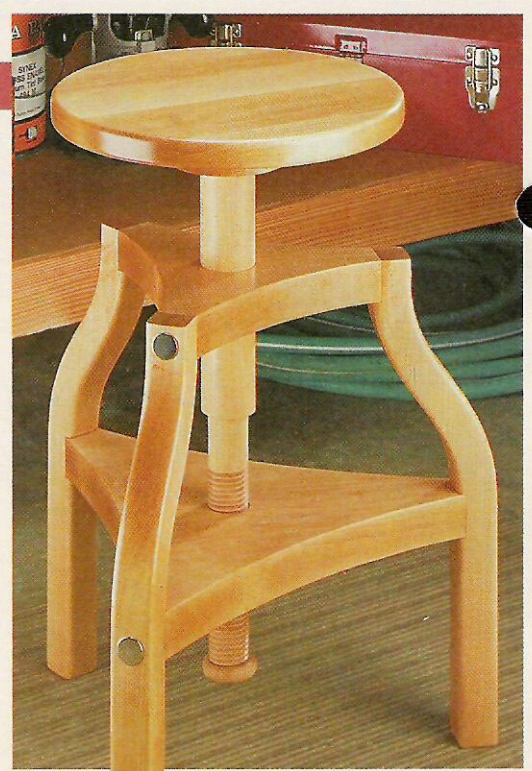

the two wide notches that will accept the supports.

CUT TO SHAPE. Once the layout is complete, the next step is to cut the legs to rough shape. A band saw makes quick work of this, see Fig. 1. As you guide the blank through the blade, stay about 1/16" to the *waste* side of the lines. Also, don't worry about cutting the notches yet. It's best to cut them in all three legs at the same time.

After cutting the leg to rough shape, it's just a matter of mounting a drum sander in the drill press and sanding up to the lines. Then use this leg as a template to lay out the other two legs and repeat the process.

CUT NOTCHES. The next step is to cut the notches for the supports.

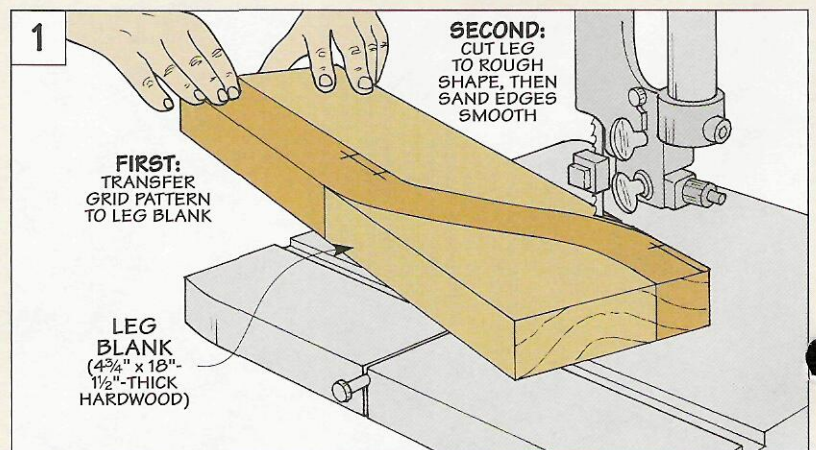
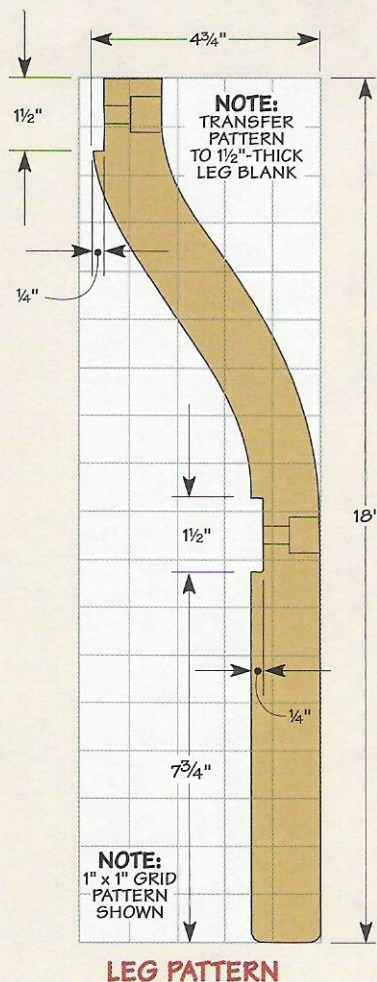

Because of the curved legs, I wasn't able to use a router or table saw. But a handsaw worked fine, at least to establish the *shoulders* of the notches.

To ensure that the shoulders align, start by clamping the legs together so the ends are flush, see Fig. 2. (A scrap block supports the curved ends of the legs.) Then extend the layout lines for the notches from the sides of the legs across the inside faces.

Now you're ready to cut the shoulders. The goal here is to end up with a clean, square-shouldered cut. So to prevent the saw blade from tilting at an angle, I made a U-shaped guide from scrap and clamped it to the legs, see Figs. 2 and 2a.

After cutting the shoulders, you can unclamp the legs and remove the bulk of the waste with a band saw, see Fig. 2b. This leaves a rough surface at the bottom of the notch. So to create a smooth, flat surface, I *routed* the rest of the waste — but *not* with a router.

DRILL PRESS ROUTING. The idea here is to use a straight bit mounted in the drill press to clean up the notch, see Fig. 3. Granted, it's a bit unusual. But it works great.

To produce a clean cut, adjust the speed of your drill press to its maximum setting. Also, since the metal table of my drill press is quite small, I attached an auxiliary table to provide support for the legs. As before, clamp the three legs together and carpet-tape the scrap block underneath.

The depth of cut is established by lowering the quill and locking it in place. (At most, remove only 1/16" of material.) Now flip the switch on the drill press and get a firm grip on the legs. As you slide the legs across the table, the bit should just shave the bottom of the notch, see Fig. 3a.

DRILL HOLES. After cleaning up all the notches, the legs are almost complete. But to mount them to the supports later on, you'll need to drill two counterbored shank holes in each leg, see Figs. 4 and 4a. Fitting scraps in the notches keeps the leg level. Plus they prevent splintering as the bit breaks through.

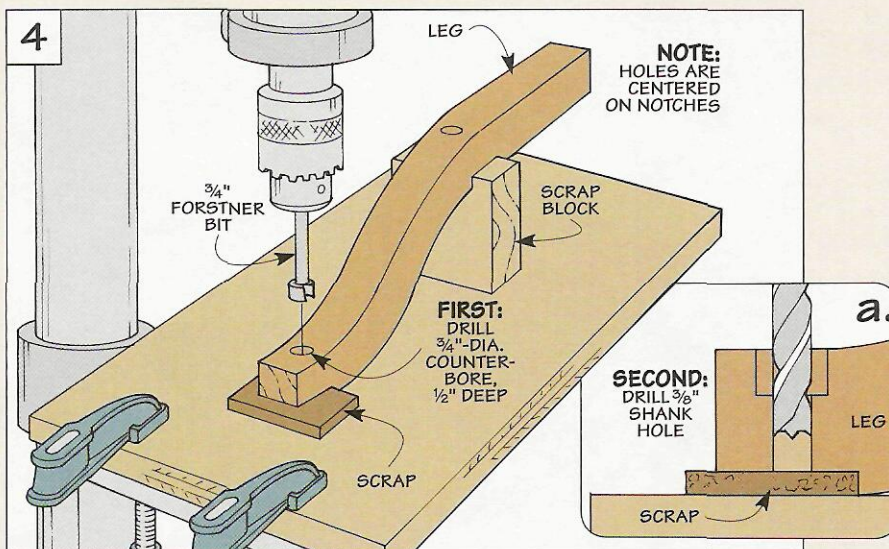
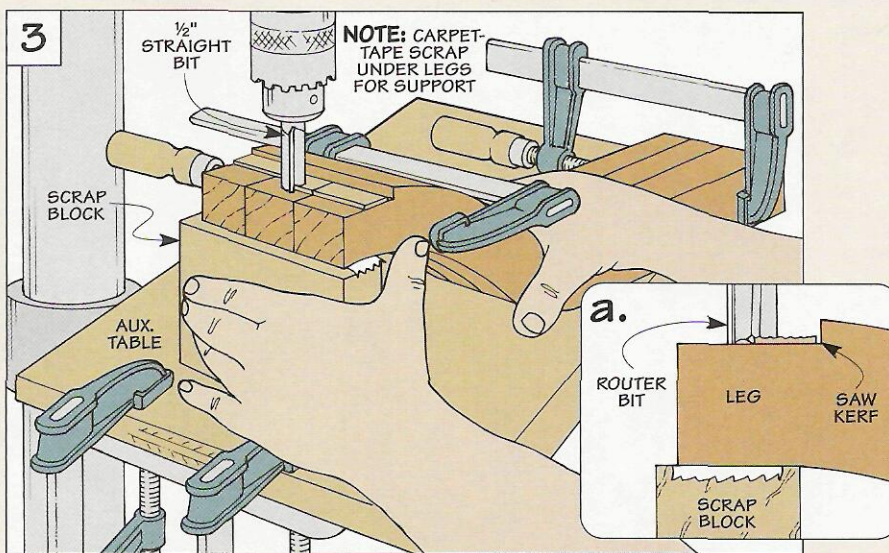
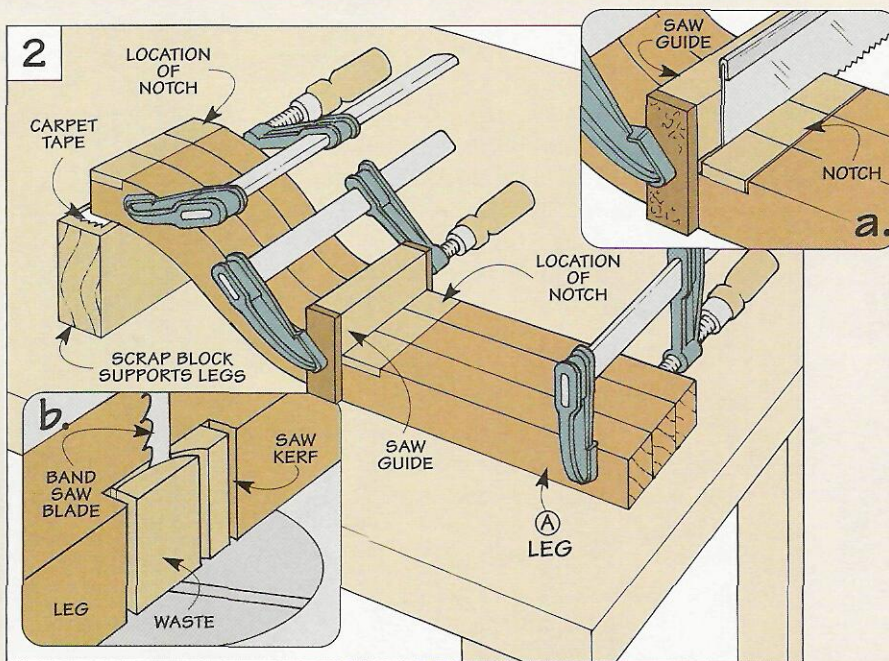

Leg Supports

The legs of this shop stool are connected by two thick, triangular supports, see drawing. Actually, they're *modified* triangles — with sweeping curves instead of straight lines. The three curved sides create narrow arms that fit into the notches in the legs.

LOWER SUPPORT

In addition to providing a convenient footrest, the lower support has another (more important) job. To make the seat adjustable, the post threads into a hole in the center of the support.

GLUE UP PANEL. I started work on the lower support by edge-gluing enough 1-1/2"-thick stock (maple) to make an 18"-wide panel, see Fig. 5. Then, after trimming the panel to a length of 16", the next step is to lay out the shape of the lower support.

LAYOUT. A large arc (8 3/4" radius) establishes the *outside* ends of the arms, see Fig. 5. The only problem is

the compass I ordinarily use was too small to draw the arc. So I made a compass from scrap, see Fig. 5a. To draw the arc, center the tip of the compass on the width of the blank and set it in 8 3/4" from one end.

The point where this arc touches the end of the blank is the *centerline* of one arm. It's used as a starting point to locate the centerlines of the other two arms.

The idea is to locate these centerlines 120° apart. This isn't difficult.

Just set the tip of the compass at the starting point. (You may need to move it in about 1/32" to "bite" into the wood.) Then draw two small arcs that intersect the large arc, see Fig. 5.

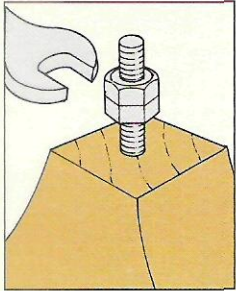
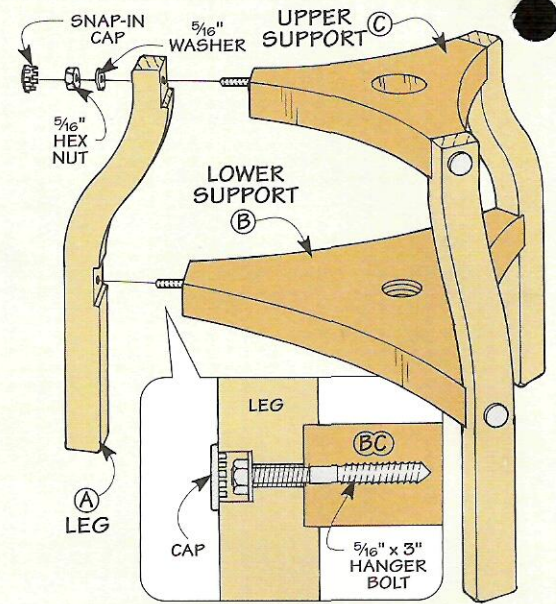

▲ Tightening two "jam" nuts against each other makes it easy to install the hanger bolts.

(These are just intermediate arcs.)

Now place the tip of the compass on one of the intermediate arcs and draw another arc. The intersecting point establishes the centerline of the first arm. Then just repeat the process for the second arm.

DEFINE ENDS. The next step is to lay out the narrow *ends* of the arms. To match the thickness of the legs, each arm is 1-1/2" wide at the end. So for one arm (the one formed by the end of the blank), all that's needed is to make a mark 3/4" to each side of the centerline, see Fig. 6. But laying out the other two arms is trickier.

To do this, you'll need to draw a line that touches the circle at one point only. (It's *tangent* to the circle). This is a two-step process. First, lay out two lines that connect the centerpoint for the hole to the intersecting arcs made earlier. Then draw two perpendicular lines (the tangent lines) and lay out the ends of the arms.

TRIANGLE. The basic groundwork is almost complete. But to make it easy to lay out the curved sides later, I drew three lines connecting the ends of the arms. (Now it's starting to look more like a triangle.)

THREADED HOLE. This is also a good time to drill the hole for the threaded post, see Fig. 6a. Then you can cut the threads inside the hole.

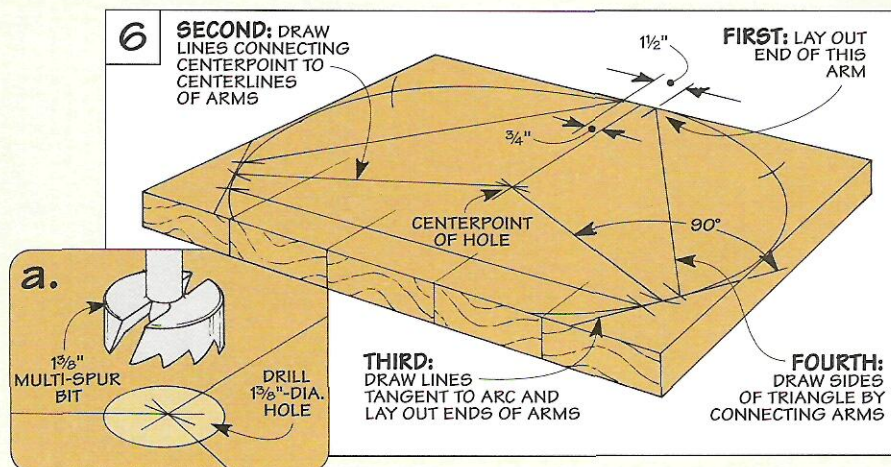
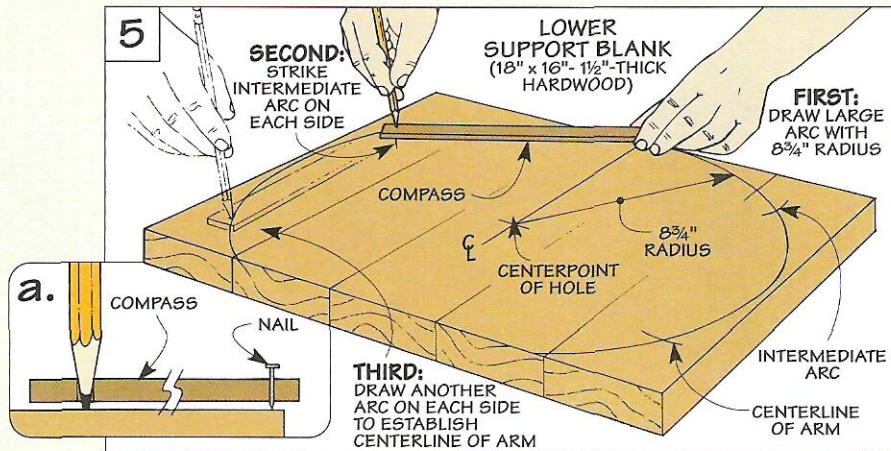

(For more on this, refer to page 13.)

TRIM CORNERS. Now you can start to shape the lower support. To create the ends of *two* of the arms, I tilted the head of the miter gauge and used the table saw to trim off the corners of the blank, see Fig. 7. (Since the blank is already squared up, you won't have to trim the third end.)

CURVED SIDES. The next step is to lay out the curved *sides* of the support. An easy way to do this is to bend a thin, flexible strip along the desired curve, see Fig. 8. (I wanted a 1" bow.)

But you'll need something to keep the ends of the strip from springing back. A couple of scraps with pointed tips work well. Just clamp the scraps to the blank so the tip aligns with the layout mark, see Fig. 8a. Then trace along the bottom edge of the strip.

CUT TO SHAPE. All that's left is to cut the lower support to shape. I roughed it out on a bandsaw then sanded the edges smooth.

UPPER SUPPORT

Except for a couple of details, the upper support is just a smaller version of the lower support.

DRY ASSEMBLY. To ensure a good fit, it's best to dry assemble the stool and turn it upside down on a blank that's been glued up for the upper support, see Fig. 9. Then simply lay out the ends of the arms.

Since I *started* with the ends, I had to work "backwards" to lay out the shape of the lower support, see Fig. 10. Here again, you'll need to drill a hole to accept the post. (It's a 2"-dia. hole to fit the thick part of the post.) But this time, the hole *isn't* threaded.

ASSEMBLY

All that's left is to assemble the two supports and the legs. You won't need glue for this.

HANGER BOLTS. That's because they're *bolted* together. The legs fit over hanger bolts installed in the ends of the arms, see drawing and margin on page 8. Tightening nuts on the ends of the bolts secures the legs. And I used snap-in metal caps to cover the bolts.

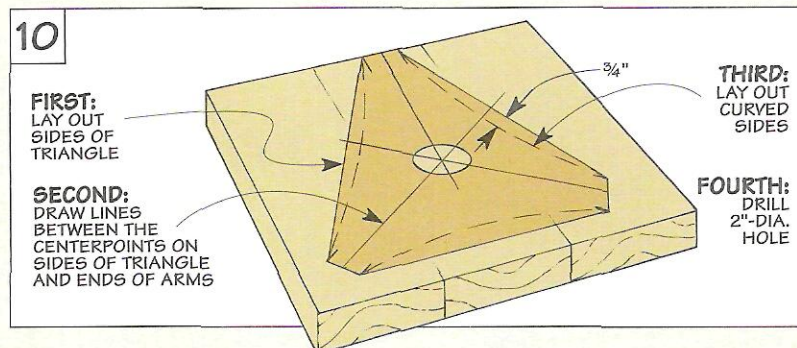
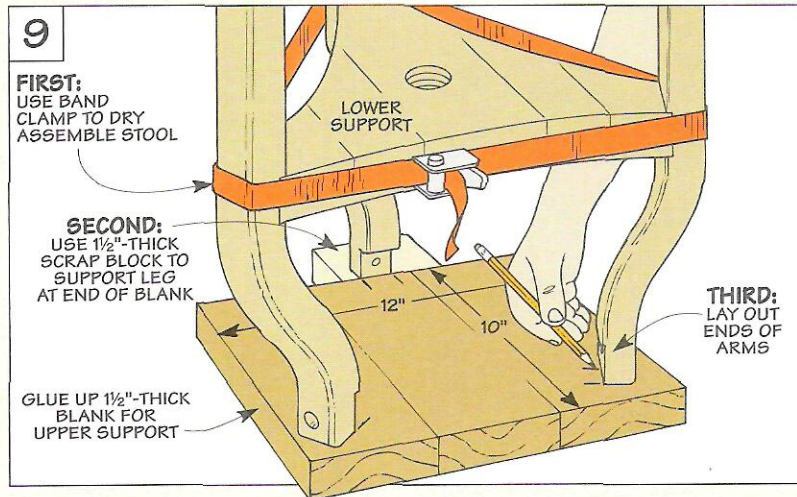
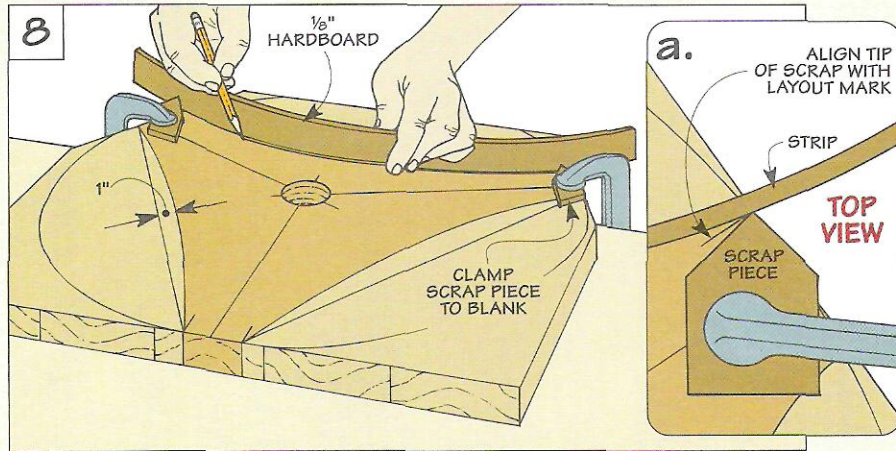
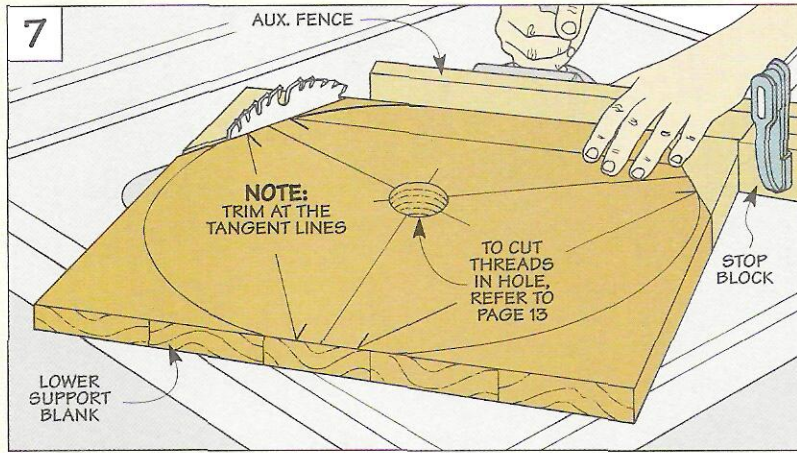

Seat & Post

With the base of the stool complete, it's time to add the seat and a threaded post to raise it up and down, see drawing at right.

SEAT & COLLAR

I began by making a large, flat disk for the *seat* (D) and a thick, doughnut-shaped *collar* (E) to support it.

GLUE UP BLANKS. To make these disks, start by gluing up two hardwood blanks. I edge-glued 1"-thick stock (maple) to make the seat blank, see Fig. 11. But to "beef up" the collar, it's 1½" thick.

CUT DISKS TO SHAPE. The next step is to cut the disks to shape. To do this, I used a simple circle-cutting jig on the band saw that uses a ¼" dowel as a pivot point, see page 29.

The dowel fits in a centered hole in each blank. I didn't want the hole in the seat to be visible. So it's only ½" deep. But I drilled a *through* hole in the collar. Later, this makes it easy to drill a centered hole for the post.

SAND EDGES. The jig also comes in handy when sanding the rough edges left by the blade. By taking it to a disk sander, it only takes a few minutes to sand perfectly round disks.

ROUT ROUNDOVERS. To keep the sharp edges of the seat from digging into my legs, I routed a ¼" roundover on the top and bottom edges. While I was at it, I rounded the bottom edge only of the collar.

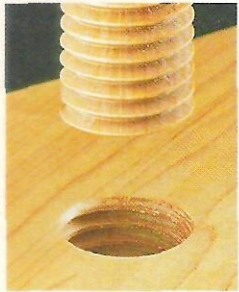

To adjust the height of the seat, the post threads into the hole in the lower support.

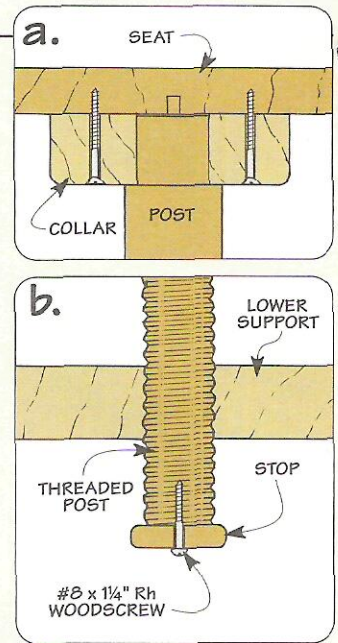
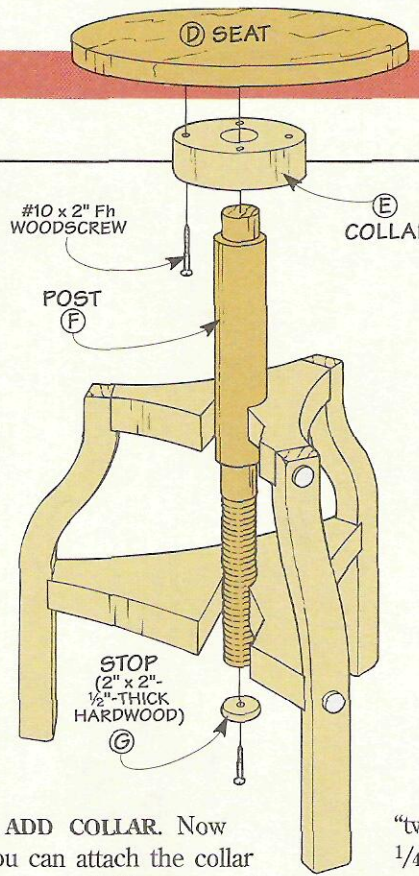

ADD COLLAR. Now you can attach the collar to the seat. To prevent the seat from wobbling, the collar needs to be perfectly centered. This is easy — especially since the holes for the pivot pins are already centered. Just stick a dowel in the hole in the seat. Then apply glue to the collar and set the pivot hole over the dowel. Installing screws clamps the pieces together and strengthens the joint.

HOLE FOR POST. Next, to accept a tenon on the end of the threaded post, you'll need to drill a large hole in the collar. Here again, centering the hole will keep the seat from wobbling.

To accomplish this, I used a simple

"two bit" trick. Start by mounting a ¼" bit in the chuck. Then set the seat on the drill press table and lower the bit into the pivot hole in the collar. After locking the quill, clamp the seat to the table and replace the ¼" bit with a 1½"-dia. bit, see Fig. 12.

This centers the tip of the bit on the pivot hole. When drilling this large hole, the bit will chew up the end of the dowel in the collar, see Fig. 12a. But that's okay. It's already served its purpose.

THREADED POST

With the seat and collar complete, you can concentrate on the *threaded post* (F), see drawing above. It's a

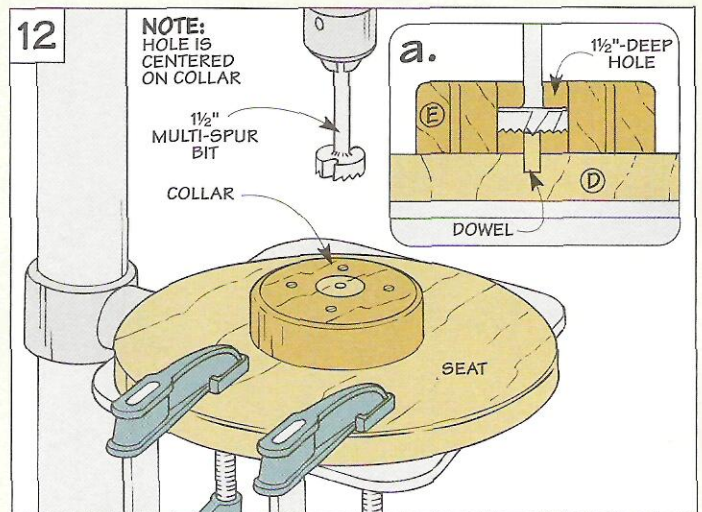
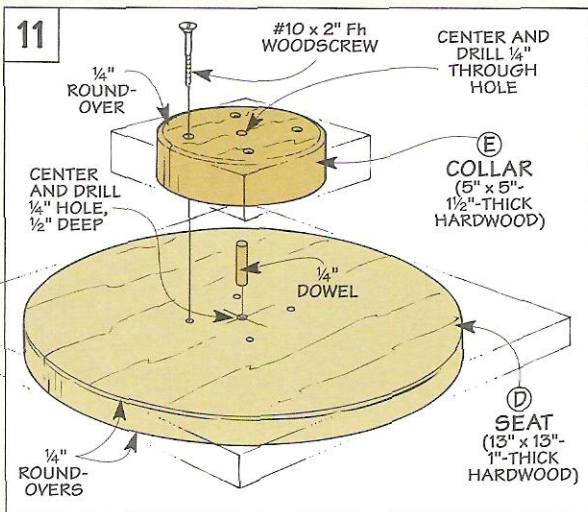

thick, wood cylinder that raises and lowers the seat.

ROLLING PIN. This cylinder is like a giant rolling pin with a different length handle at each end. At the top end, a short tenon fits into the hole in the collar, see detail 'a.' And a long shaft on the bottom end threads up and down through the hole in the lower support, see detail 'b.' To prevent the post from flexing, a thick barrel (in the middle) fits inside the hole in the upper support.

DOWEL. The barrel determines the size of the dowel used to make the post. I used a 2"-dia. maple dowel and cut it to a rough length of 22", see drawing at right.

The next step is to turn the shaft and tenon to size. The shaft is sized to fit a 1½"-dia. threadbox (or router jig) that's used to cut the threads. And the tenon will fit in the 1½"-dia. hole in the collar.

TABLE SAW "TURNING." You could use a lathe to size the shaft and tenon. But I took a different approach that involves "turning" them to size using a table saw and a dado blade.

To do this, set the dado blade to make a *very shallow* (1/16") cut, see Figs. 13 and 13a. I also mounted an L-shaped fence to the miter gauge to support the post during the cut.

Why not use a regular fence? (You know, a scrap attached to the miter

gauge.) Well, I tried that. But with the dowel close to the miter gauge, I got a cramp in my hands from spinning it. The L-shaped fence prevents that by supporting the dowel out in front (away from the miter gauge).

Before you get started, make sure the fence is clamped in place. I positioned it so the dowel would be centered over the saw blade, see Fig. 13a. Also, lock the rip fence in place and use it as a stop to establish the shoulder of the shaft (or tenon).

SHAFT. To form the shaft, hold the end of the dowel against the fence and lower it onto the spinning blade. Now slowly rotate the dowel toward you as if you're nibbling kernels off an ear of corn. After one full revolution, lift the dowel, move it away from the fence, and repeat the process.

To prevent the dowel from tipping into the blade, leave a band of waste to support the end of the shaft. Just be sure it's wide enough that it doesn't drop into the miter gauge slot. (A 1½"-wide band is plenty.)

After working your way to the end of the shaft, raise the blade another 1/16" and make another series of passes. Then continue this process until the shaft is the correct diameter to fit into the threadbox. Note: The tenon is made in the same way.

CUT THREADS. Once everything is sized correctly, it's time to cut the

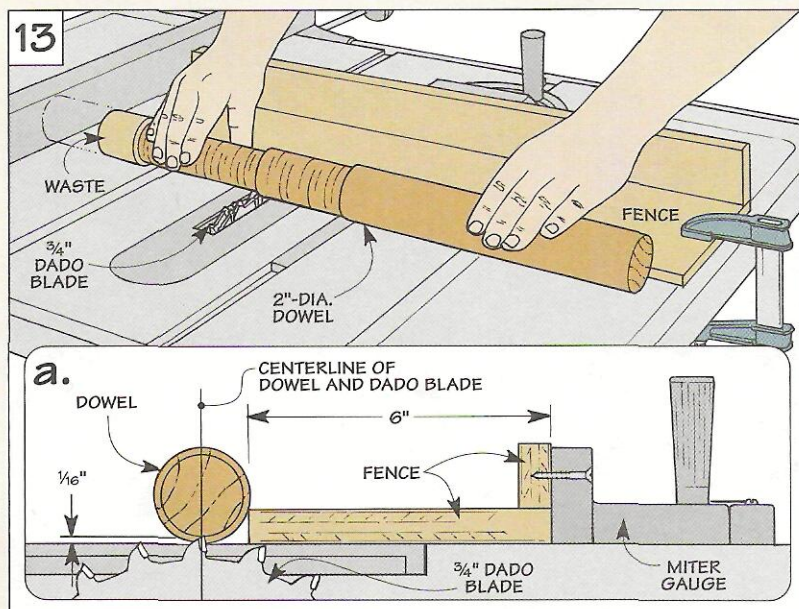
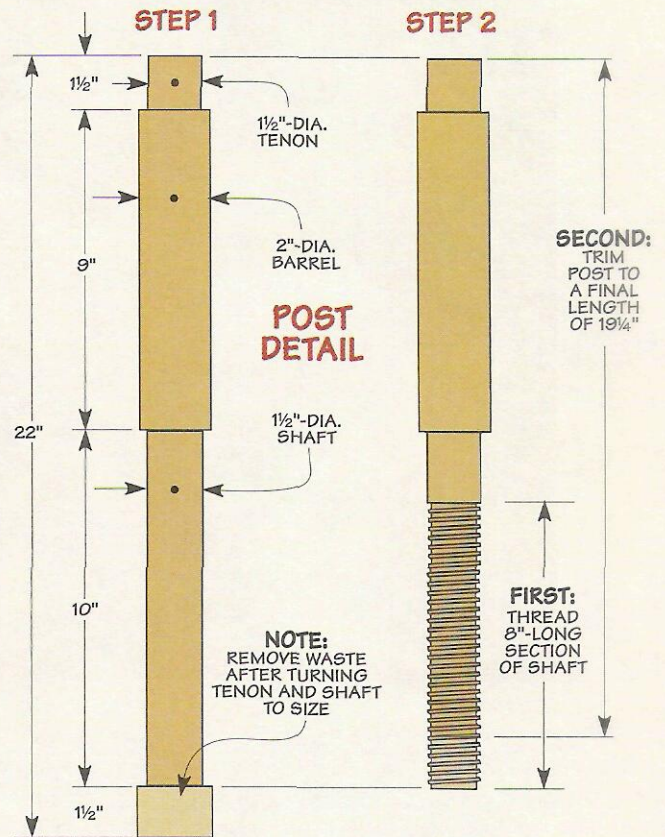

threads in the shaft. To fit the shaft into the threadbox, you'll need to trim the waste off the end. Then thread about an 8"-long section of the shaft, see Step 2 in drawing above. (For more on this, see page 14.)

TRIM POST. This threaded section is longer than what's actually needed. So before attaching the seat, I used a hand saw to trim the post to final length, see Step 2 above.

GLUE IN POST. Now it's just a matter of gluing the post into the collar. The tenon should fit snugly in the hole, so no clamps are needed. But after applying glue and inserting the tenon in the hole, twist the post around to distribute the glue evenly.

ASSEMBLY. Once the glue dries, all that's left is to lower the end of the post down through the hole in the upper support and thread it into the hole in the lower support.

FINAL DETAILS. Applying a finish and some paste wax will make the post spin freely. Finally, to prevent the post from threading out of the hole, screw a stop (G) to the bottom end. (I just used a toy wheel.)

Cutting Threads

In Wood

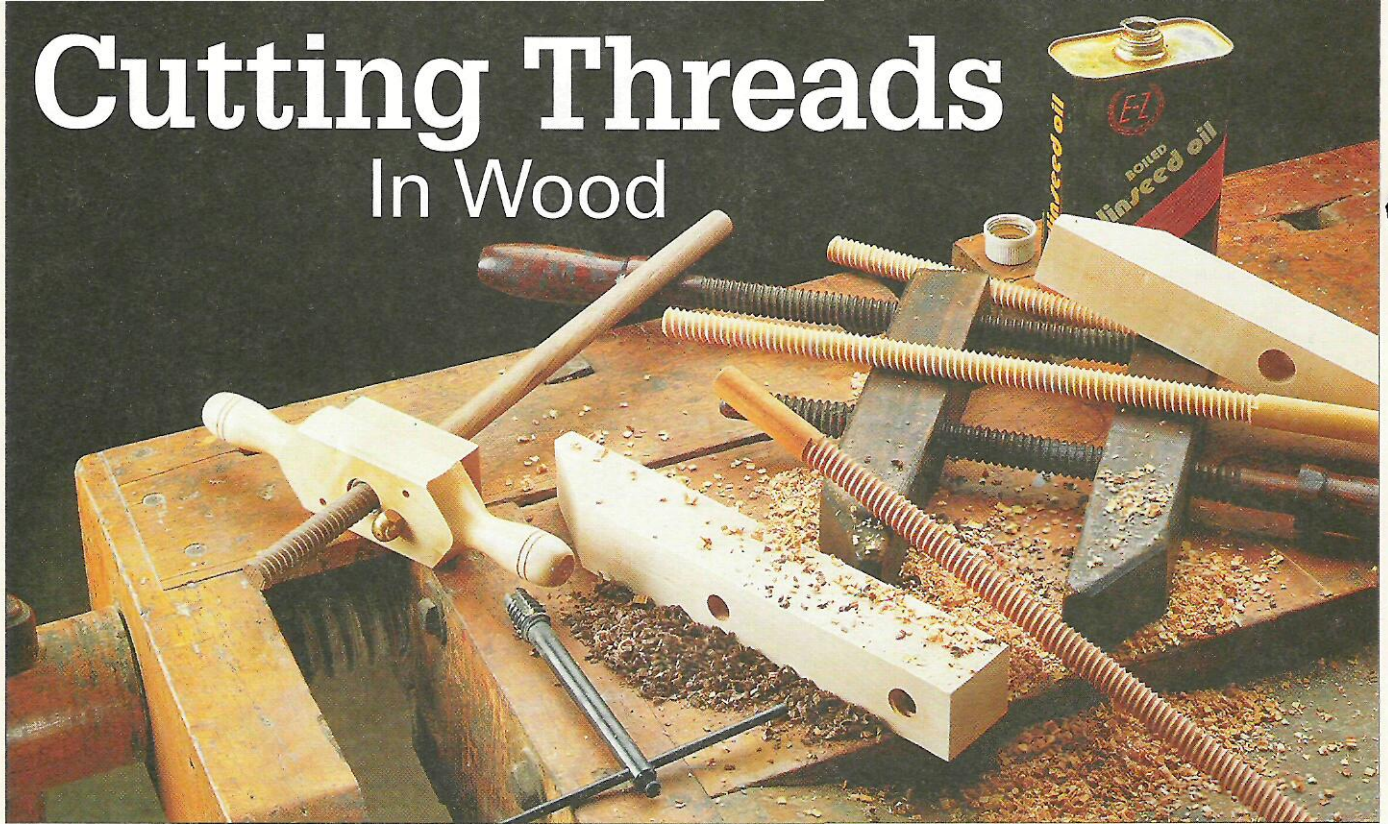

As a kid, I spent hours opening and closing the vise on my grandfather's workbench. It had massive wood jaws, a wood handle, and best of all, a large *wooden screw* that threaded in and out of the bench.

Ever since then, I've been fascinated by projects with wood threads. Deep, V-shaped threads spiral around the *outside* of a wood cylinder. And these threads mesh together with threads *inside* a hole — like a bolt in a nut, see photo at right.

But to be honest, I've always been a bit intimidated about building a project that required *cutting* wood threads. To prevent the threaded parts from binding, the threads would have to be identical — *inside and out*. And that sounded complicated.

As it turns out, I was right about one thing. To get the threaded parts to fit smoothly together, the size and

spacing of the threads *does* have to be consistent. But cutting uniform threads isn't as difficult as it sounds. In fact, all you need are two simple tools.

TAP & THREADBOX. The inside threads are formed by drilling a hole and gradually twisting a *tap* down into it. (The tap is the metal tool with a T-shaped handle in the photo above.)

To cut the outside threads, you spin a *threadbox* (the wood block with the turned handles) around a dowel. Note: You can also *route* the threads, see page 15. Either way, it's important to start by selecting the right dowels, see box on page 13.

SIZE. Threading tools are available as matched sets that range from 1/2" to 1 1/2",

see Sources on page 31. (The size refers to the dia. of the dowel that can be threaded.) So it's best to have a project in mind before buying a set, see photos below.

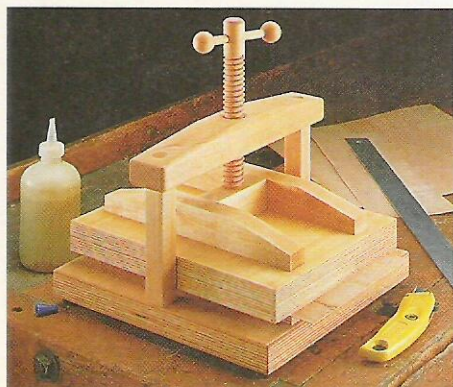
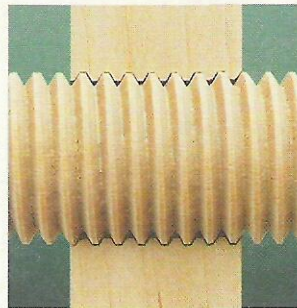

▲ **Veneer Press.** Tightening a single wood screw applies all the clamping pressure that's needed for this small veneer press.



▲ **Small-Piece Clamps.** These clamps are ideal for delicate work. Just thread a short dowel. Then tap threads in the lower nut.

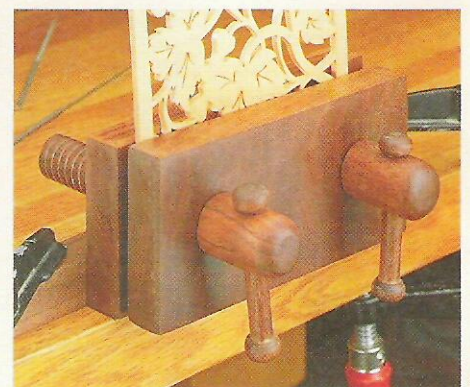

▲ **Benchtop Vise.** The twin wood screws on this small, benchtop vise thread into tapped holes in the back jaw.

Inside Threads

I begin a threading project by cutting the *inside* threads with the tap, see photo. Later, this makes it easy to test the fit of the outside threads on the dowel and make any necessary adjustments to the threadbox.

PILOT HOLE. The first step is to drill a pilot hole for the tap. As a rule, this hole should be $\frac{1}{8}$ " smaller than the tap. (For example, drill a $1\frac{3}{8}$ " hole for a $1\frac{1}{2}$ " tap.) This way, there's plenty of material to form the threads.

LUBRICATION. The tap will fit quite snug in the hole. So to make it easy to turn, it's best to apply a generous amount of oil. (I use linseed oil.)

CUT THREADS. After letting the oil soak in, it's time to cut the threads. The bottom end of the tap has a slight taper that helps center it in the hole, see Step 1 in drawing below.

Even so, the important thing is to make sure the tap goes straight into the hole. (It will still cut if it goes in at an angle, but the dowel that threads into the hole will wobble.)

To accomplish this, twist the tap *slowly* and *evenly* in a clockwise direction, applying a small amount of downward pressure, see Step 2. At first, the tap should turn freely, as if you're opening a can with a can opener. But

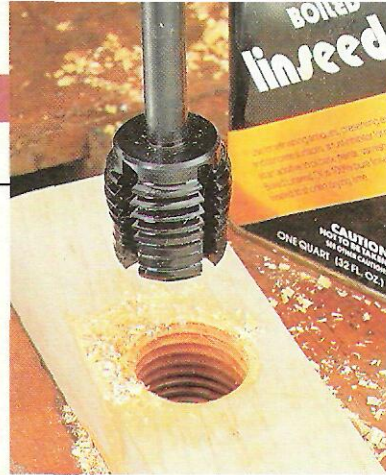

after a couple of turns, you'll start to feel resistance. At that point, back the tap out about a quarter of a turn to clear the chips, see Step 3.

Now simply repeat this process until the tap cuts all the way through the hole, see Step 4.

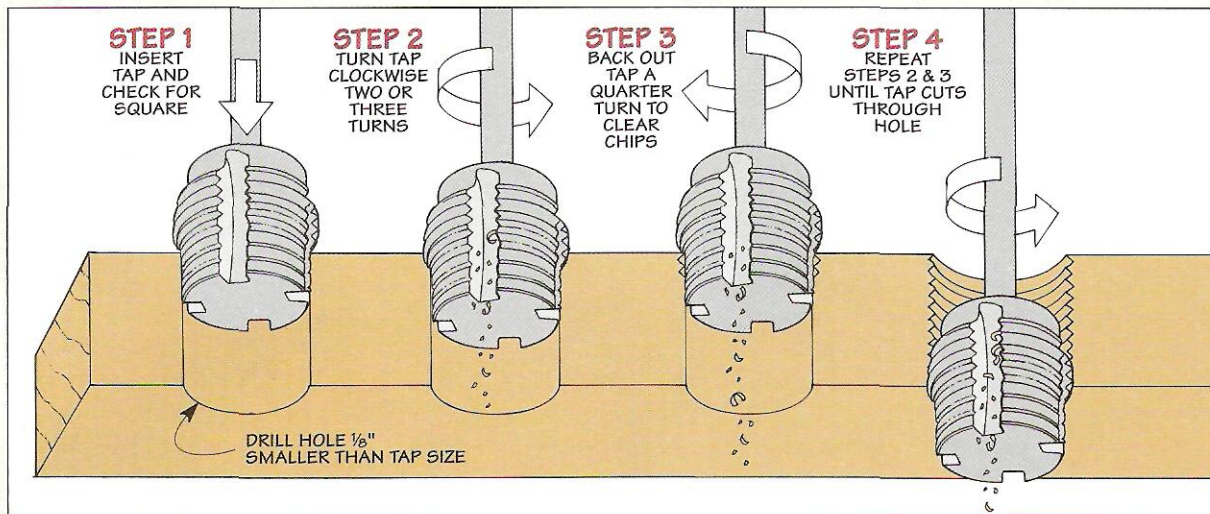

Selecting Dowels

The secret to ending up with crisp, clean threads is selecting the right dowels.

TYPE OF WOOD. For starters, stick with close-grained hardwoods like maple, cherry, or birch. (I've also had good results with walnut.) Open-grained woods (like oak) have a frustrating tendency to chip out.

STRAIGHT. You'll also want to check that the dowel is *straight*. It's difficult to cut consistent threads if it's bowed. Also, make sure it's free of knots or defects.

SHAPE. The *shape* of the dowel is also important. As the wood dries, the dowel may go out of round. (You'll know by the egg-shaped ends.) These dowels feed

crookedly through the threadbox which causes the threads to chip.

SIZE. One final consideration is the *size* (diameter) of the dowel. Many dowels are slightly smaller or larger than their stated size. So you may want to take the threadbox with you to the lumberyard and check the fit.

What you're looking for is a smooth, sliding fit. If it's too tight, the dowel will bind as you cut the threads. (Some dowels won't even fit in the threadbox.) If the dowel is too loose, you'll end up with slop in the threads. (For sources of "true" dowels, see page 31.)

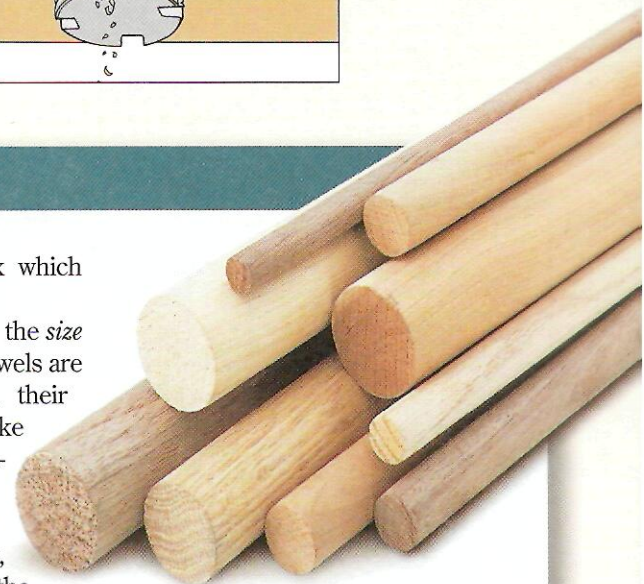

▲ *There's more to selecting a dowel than simply choosing the type of wood. Especially if you plan on cutting threads in the dowel.*

Outside Threads

Once the threads are cut inside the hole, you're halfway done. Now it's time to pick up the threadbox and cut the *outside* threads in the dowel.

TWO PARTS. The threadbox consists of two wood blocks that house a V-shaped cutter, see drawing below. The cutter fits into a notch in a threaded post. Tightening a nut on the end of the post locks the cutter in a "pocket" in the upper block.

Just a word of caution. The post is made of brass, so it's fairly soft. So to avoid bending (or breaking) it, be careful not to overtighten the nut.

METAL INSERT. The cutter is positioned right next to a metal insert in the upper block. This insert is *threaded* to match the threads cut by the *tap*. The reason is simple.

When you rotate the threadbox around the dowel, the cutter makes a groove that immediately "catches" the threads in the insert. These threads then *pull* the cutter around the dowel. This creates a spiral groove that fits the threads in the tapped hole.

CHAMFER & OIL. To get the first thread started (and keep the fragile edge from chipping), I sand a chamfer on the end of the dowel. Here again, applying oil softens the wood fibers



and makes it easier to cut the threads.

TEST CUT. The threadbox I used was already adjusted by the manufacturer. But it's still a good idea to cut threads in a scrap piece and check the fit of the dowel in the tapped hole.

Don't expect wood threads to fit as tightly as metal threads. (A good fit will seem a bit loose.) This prevents the threaded parts from binding when the wood expands or contracts with changes in humidity. Note: To improve the fit, adjust the depth of

cut by sliding the cutter in or out.

CUT THREADS. Once you're satisfied with the fit, clamp the "real" workpiece vertically in a vise and lower the threadbox onto the end of the dowel. You'll feel a "thunk" as the cutter contacts the end of the dowel.

Now grip the threadbox by the handles and slowly rotate it in a *clockwise* direction. At the same time, apply steady, even pressure downward. There's not much resistance — about as much as using a corkscrew.

If the threadbox gets harder to turn, it's probably because chips have clogged the throat opening. To clear the chips, simply back off the threadbox about a quarter of a turn.

As you continue to turn the threadbox, it will work its way down the dowel. This exposes the newly cut threads on the end of the dowel.

THREAD SHAPE. The ridges on these threads are fairly sharp, see detail 'a.' Because of this, they're a bit fragile, and they may chip with use. But that won't weaken the thread. The thick *root* of the thread that fits in the groove provides the strength.

UNSCREW THREADBOX. Once the dowel is threaded to the desired length, there's just one thing left to do. That's to "unscrew" the threadbox by backing it all the way off the dowel.

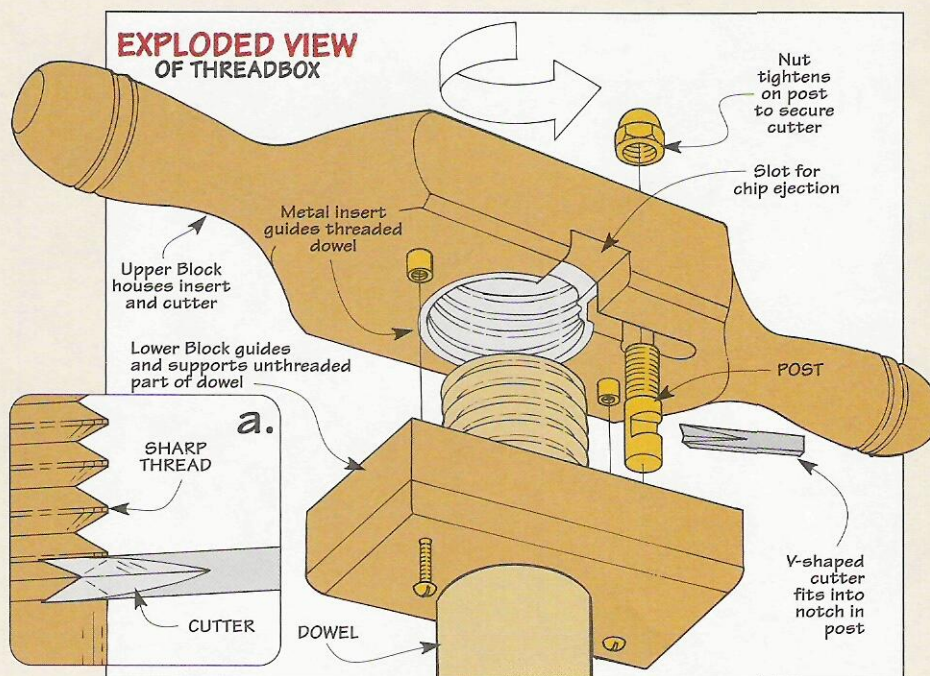

Routing Outside Threads

If you're making a lot of threaded parts, you can cut the outside threads quickly and accurately with a router and a simple jig, see photo. Note: We used a jig manufactured by the Beall Tool Company, see Sources on page 31.

TAP. Here again, the jig comes with a tap used to cut inside threads, see inset. The tapered "nose" of this tap is removable, so you can cut threads to the bottom of a stopped hole. (You'll need to buy a separate "bottoming" tap to do this with the threadbox kits.)

SETUP. After tapping the hole, setting up the jig only takes a few minutes. The base of the router is attached to a metal *mounting plate* that's screwed to a hardwood *support block*, see drawing below.

This support block holds a plastic *insert* that's threaded on the inside to guide the dowel. As the dowel is twisted through the insert, a special V-groove bit cuts the grooves that form the threads, see margin.

As before, the grooves "follow" the threads in the insert. But here, the first thread is centered on a hole in the top of the insert. So to ensure accurate results, the tip of the bit must be centered on this hole.

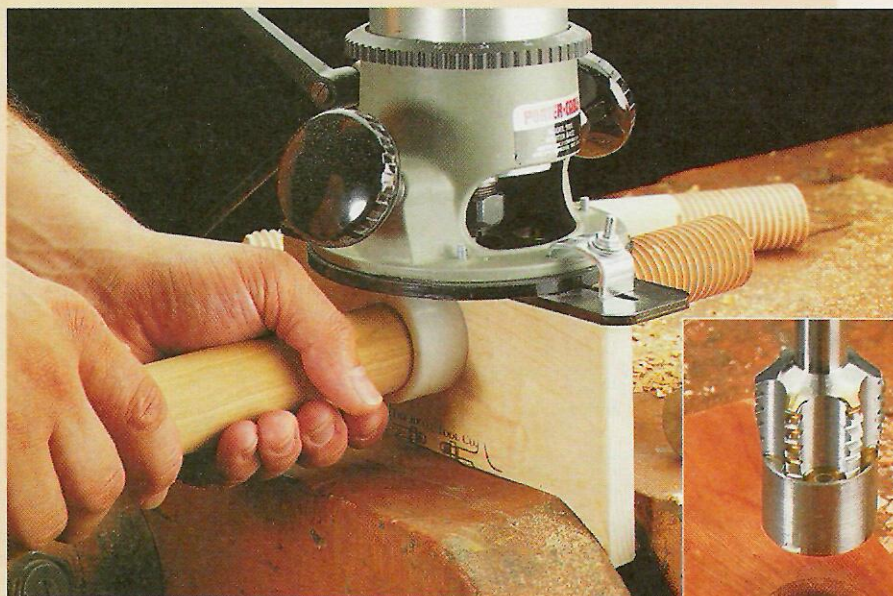

▲ To rout the outside threads in a dowel, twist it through the plastic insert in this jig like you're making sausage. A hand-held tap cuts the inside threads, see inset photo.

SLEEVE. The solution is a metal sleeve that fits into the hole in the insert, see detail 'b.' To center the bit, you just mount it in the router and lower the sleeve.

MOUNT ROUTER. Before removing the sleeve, secure the router to the mounting plate with a pair of

brackets. Be sure the brackets are tight. You don't want the router to shift. Also, don't forget to remove the sleeve. (You'll have to lift the motor housing out of the base to do this.)

DEPTH OF CUT. After reinstalling the motor housing, lower the bit until the tip sticks down into the insert about 1/32". This is a good starting point. But you'll want to cut some test threads to make sure they fit.

ROUT THREADS. To do this, flip the router on and stick the end of the dowel into the insert until it "bottoms out." Now slowly rotate the dowel in a clockwise direction.

It's helpful to hold the dowel close to the jig. If you hold it at the end, there's too much leverage. And even a small amount of movement up or down will tip the opposite end into the bit and chip the threads.

THREAD SHAPE. After threading part of the dowel, take it out and look at the threads. They're fairly flat on top, see detail 'a.' So these threads won't be as likely to chip as the sharp threads cut by the threadbox. The goal is the widest "flat" possible that turns smoothly through the tapped hole. If you need to "fine tune" the fit, just adjust the depth of cut. ▲

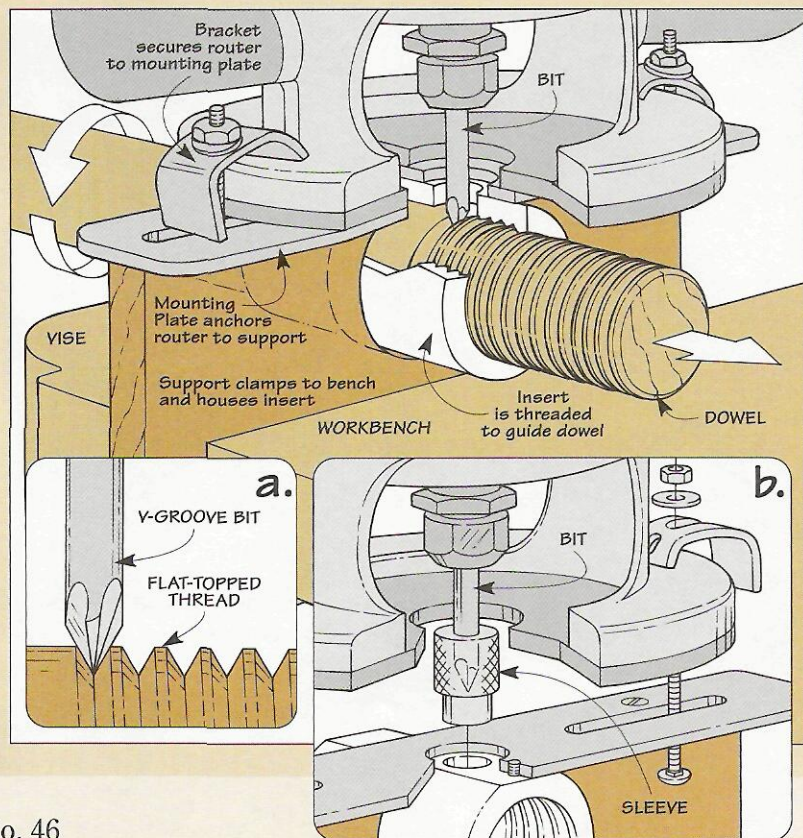

▲ A solid carbide V-groove bit used to cut the threads won't need sharpening nearly as often as the cutter in the threadbox.

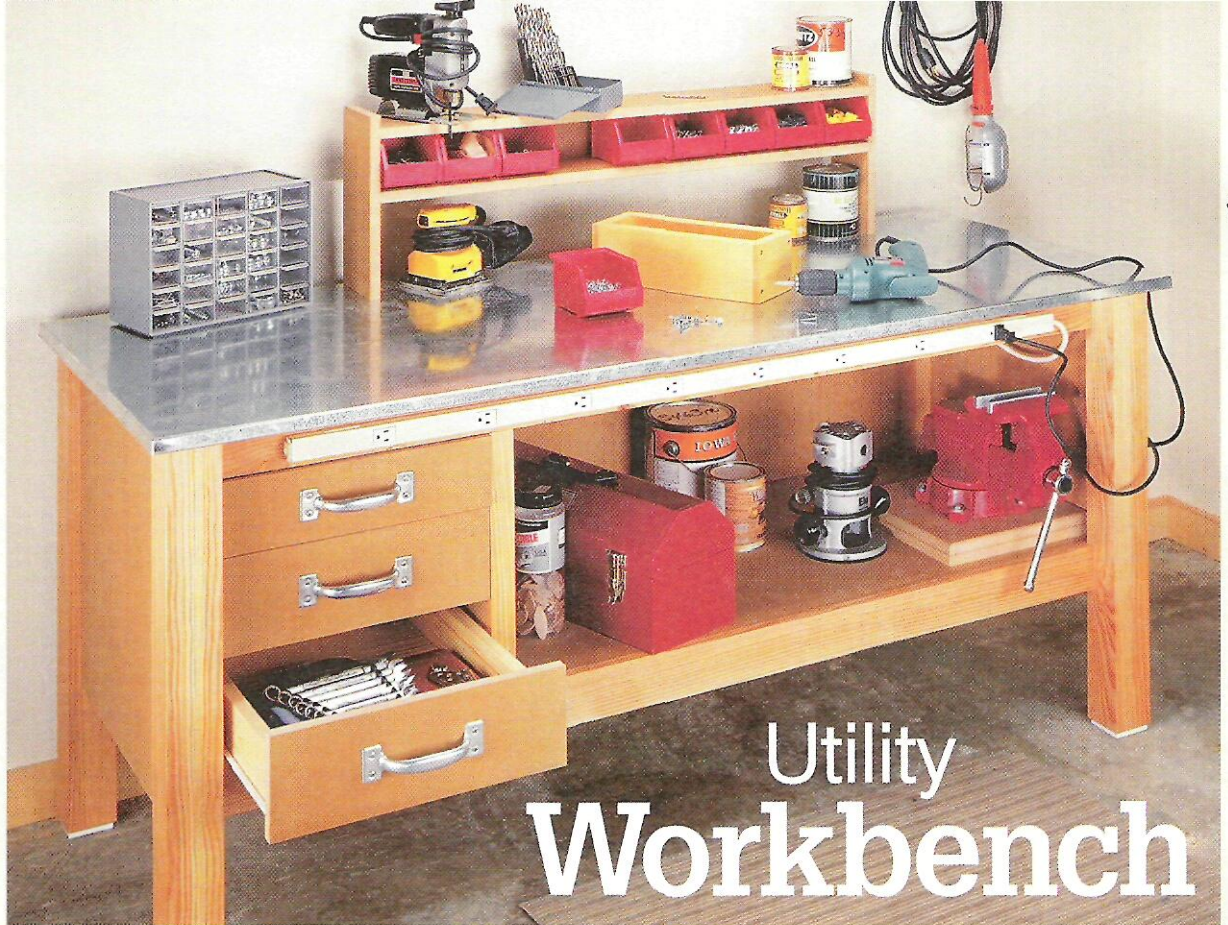

The metal top on this bench creates a tough, durable work surface that's ideal for dirty, messy jobs.

It's always the messy jobs that I put off. Things like changing the oil in the lawnmower, fixing a greasy bicycle chain, or working on my chainsaw.

Not that these jobs are particularly difficult. It's just that I don't want the work surfaces in my shop to get dented or covered with gunk (especially the ones I use for wood-working). As a result, I often end up working on the floor.

So recently, as I was hunched over a project (and up to my elbows in grease), I decided that what I really needed was a *utility* workbench — a bench with a heavy-duty top that would take a beating *and* clean up easily.

That's when I remembered a tip I'd received from *John Wofford* of Silver Spring, Maryland. He had built a general-purpose tool stand with a *metal* top, and it sounded

like a perfect solution for my bench as well. The only question was where to get a metal benchtop.

METAL COVER. After checking around a bit, I found the answer at a local heating and air conditioning company. Using a special bending tool, they folded the edges of a large piece of sheet metal to make a metal cover.

This metal cover fits over the top of the bench like a lid on a trash can. I used $\frac{3}{4}$ " Medium-Density Fiberboard (MDF) for the top. This is a hard, flat material. So placing the metal cover over the MDF top creates a tough, durable work surface. And best of all, it only takes a second to wipe off a greasy mess, see photo A below left.

SOLID CONSTRUCTION. Another thing I like about this bench is its solid construction. It's made of straight-grained Douglas fir and $\frac{3}{4}$ " MDF. Together, they help strengthen the bench. Plus, they add a considerable amount of weight. (The bench "weighs in" at about two hundred pounds.)

EASY TO BUILD. Now you might expect a bench like this would require a lot of complicated joinery and take a long time to build. But that's not the case.

Using simple rabbet and dado joints, the parts of the bench fit together like pieces of a jigsaw puzzle. In fact, you can build the basic bench in one weekend. Then add a set of drawers and a small storage unit the next, see photo B.

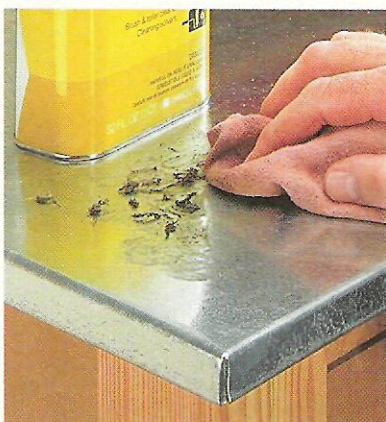

A. Metal Cover. The metal cover on the workbench cleans up easily. And solvents won't damage the surface.



B. Storage Unit. Besides keeping supplies handy, this storage unit holds plastic bins that help organize small pieces of hardware.

FEATURE PROJECT

EXPLODED VIEW OVERALL DIMENSIONS: (68"W x 33³/₄"H x 26³/₄"D)

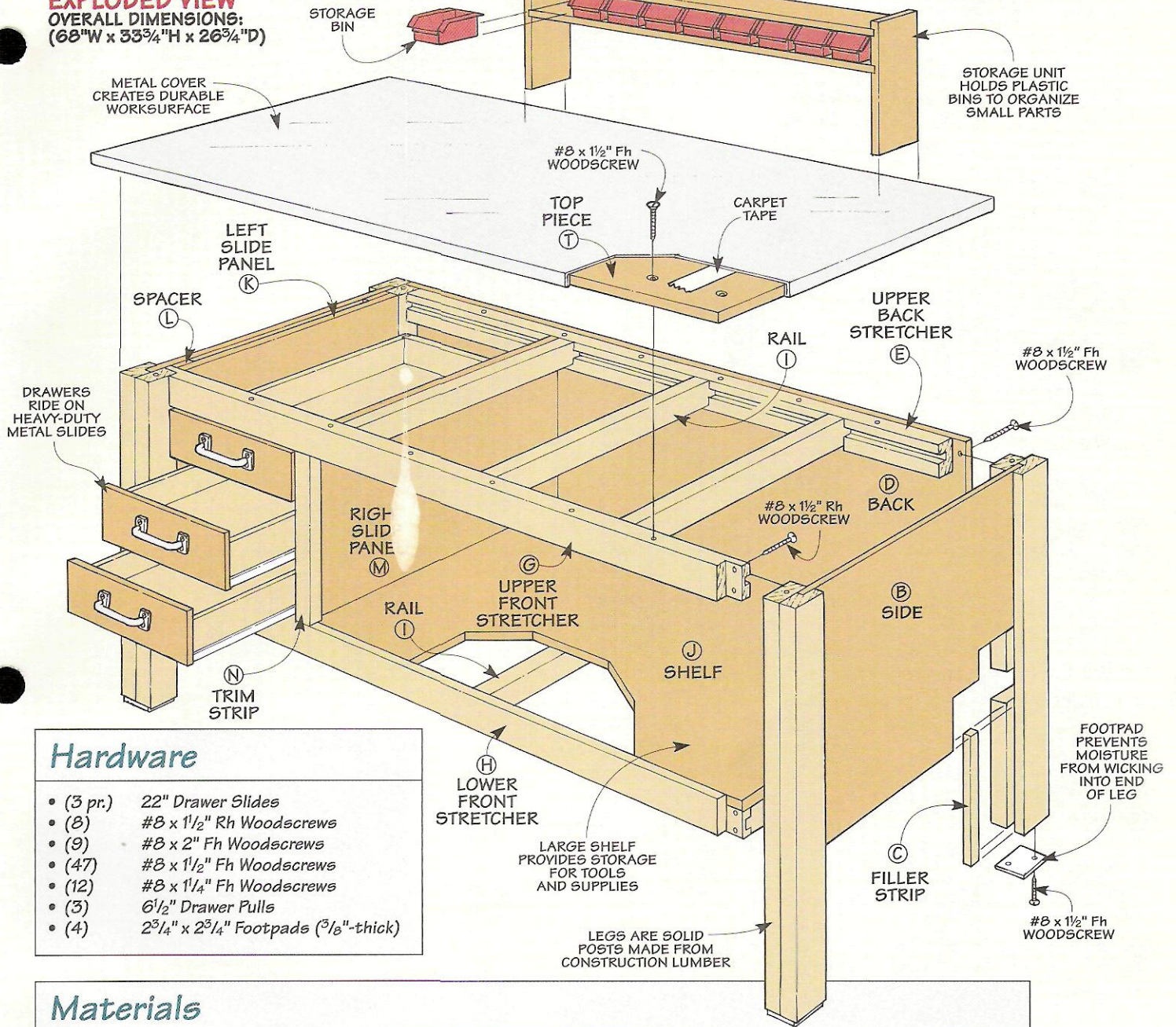

Hardware

- (3 pr.) 22" Drawer Slides
- (8) #8 x 1¹/₂" Rh Woodscrews
- (9) #8 x 2" Fh Woodscrews
- (47) #8 x 1¹/₂" Fh Woodscrews
- (12) #8 x 1¹/₄" Fh Woodscrews
- (3) 6¹/₂" Drawer Pulls
- (4) 2³/₄" x 2³/₄" Footpads (³/₈"-thick)

Materials

Base

A Leg Pieces (8)	1 ¹ / ₂ x 3 - 33
B Sides (2)	21 x 21 ¹ / ₄ - ³ / ₄ MDF
C Filler Strips (4)	³ / ₄ x ³ / ₄ - 12
D Back (1)	21 x 63 - ³ / ₄ MDF
E Upper Back Stretcher (1)	1 ¹ / ₂ x 3 - 60
F Lower Back Stretcher (1)	1 ¹ / ₂ x 2 ¹ / ₄ - 63
G Upper Front Stretcher (1)	1 ¹ / ₂ x 3 - 63
H Lower Front Stretcher (1)	1 ¹ / ₂ x 3 - 63
I Rails (7)	1 ¹ / ₂ x 2 ¹ / ₄ - 19 ³ / ₄
J Shelf (1)	22 x 45 ¹ / ₂ - ³ / ₄ MDF

Drawers & Top

K Left Slide Panel (1)	18 x 19 ³ / ₄ - ³ / ₄ MDF
L Spacers (2)	2 x 18 - ³ / ₄ MDF
M Right Slide Panel (1)	18 x 22 - ³ / ₄ MDF

N Trim Strip (1)	1 ¹ / ₂ x 1 ¹ / ₂ - 15
O Front/Backs (6)	³ / ₄ x 3 ¹ / ₂ - 14
P Sides (6)	³ / ₄ x 3 ¹ / ₂ - 22
Q Bottoms (3)	14 x 21 - ¹ / ₂ Plywood
R Narrow False Front (1)	4 x 15 ³ / ₄ - ³ / ₄ MDF
S Wide False Front (2)	5 ¹ / ₄ x 15 ³ / ₄ - ³ / ₄ MDF
T Top Piece (1)	26 ³ / ₄ x 68 - ³ / ₄ MDF

Storage Unit

U End Pieces (2)	5 x 12 - ³ / ₄ MDF
V Shelves (2)	5 x 38 ¹ / ₂ - ³ / ₄ MDF
W Back (1)	4 ¹ / ₂ x 38 - ¹ / ₄ Hardboard

Note: You'll need (1³/₄) sheets of Medium-Density Fiberboard (MDF), (3) 2 x 12 pieces of Douglas fir (eight feet long), and (3) 1 x 4 pieces of pine (eight feet long) for this project.

Base

There's one thing for sure about this utility bench. It won't budge when working on a project. That's because it's designed with a heavy base that adds mass and stability to the bench.

END ASSEMBLIES. The base starts out as two *end assemblies* connected by a back, see drawing. Each end assembly is made up of two legs and a side.

LEGS. The legs are thick posts made by gluing up two pieces of 1½"-thick stock, see Fig. 1. To accept the sides (added later), I mounted a dado blade in the table saw and cut a long groove down the length of each leg, see Step 1 in Fig. 1.

At this point, you can set the front legs aside. But the back legs still need some work. To create a notch for a stretcher and a shelf, start by cutting a wide dado in the inside face of each leg, see Step 2 in Fig. 1. You'll also need to rabbet the back inside edge of each leg to hold the back, see Step 3 in Fig. 1.

SIDE PANEL. After completing all four legs, you're ready to add the two *sides* (B), see drawing above. These sides are ¾" MDF panels that fit into the grooves in the legs, see details 'a'

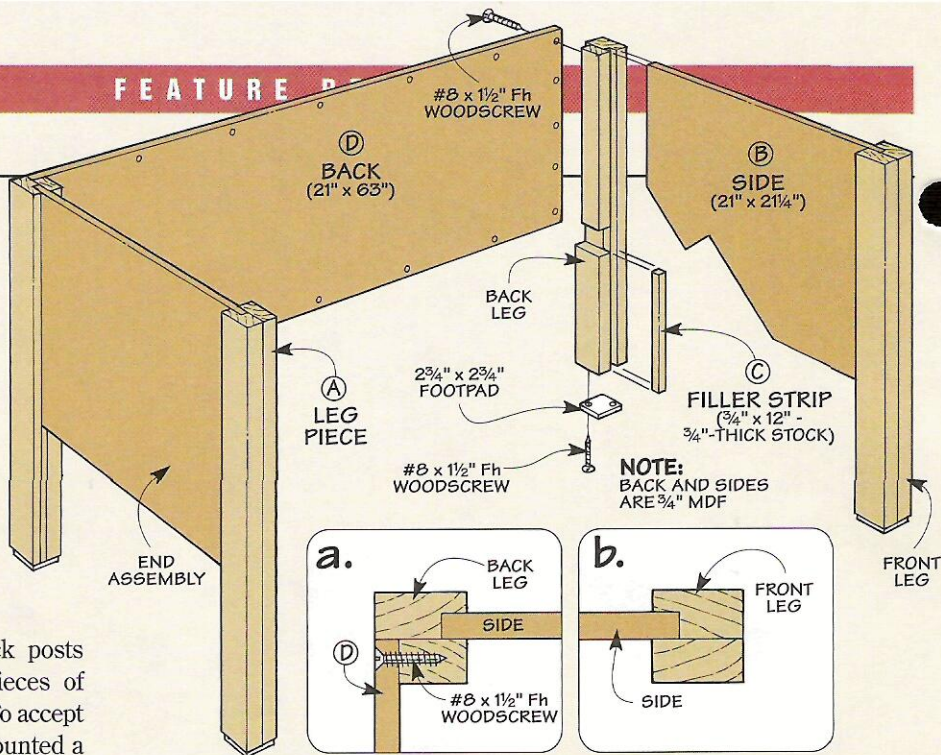

To make inexpensive footpads for the legs, I cut squares from an ordinary plastic cutting board.

and 'b' above. After positioning the sides flush with the top of the legs, they're simply glued in place.

FILLER STRIPS. But this means that the part of the groove *below* the side is still exposed. So I glued a *filler strip* (C) into each groove.

FOOTPADS. The bottom ends of the legs also need some attention. To prevent the end grain from wicking up moisture, I screwed a plastic footpad to each leg, see margin.

BACK. The next step is to add the *back* (D). It's a large MDF panel that connects the two end assemblies and keeps the bench from racking.

After cutting the back to size, it's simply screwed to the legs.

STRETCHERS & RAILS

Now that the base was starting to take shape, I added a system of stretchers and rails to provide support for the top and shelf, see drawing on top of page 19.

BACK STRETCHERS. I began with two long stretchers that span the back of the bench, see Fig. 2. An *upper back stretcher* (E) is cut to length to fit between the two rear legs. But the *lower back stretcher* (F) rests in the dados cut earlier in the legs, so it's 3" longer.

The length isn't all that's different about the back stretchers — they're also different in width. The upper back stretcher is 3" wide. But I ripped the lower back stretcher to a width of 2¼", see Fig. 2b. This way, when the stretcher is set in the dado, there will be ¾" clearance above it — just enough to slide in the shelf.

Before attaching the stretchers, there's one more thing to do. To accept the rails, you'll need to cut a groove down the length of each piece, see Figs. 2a and 2b. Then just clamp the stretchers in place and secure them with screws driven through the back of the bench.

FRONT STRETCHERS. Now you can turn your attention to the two

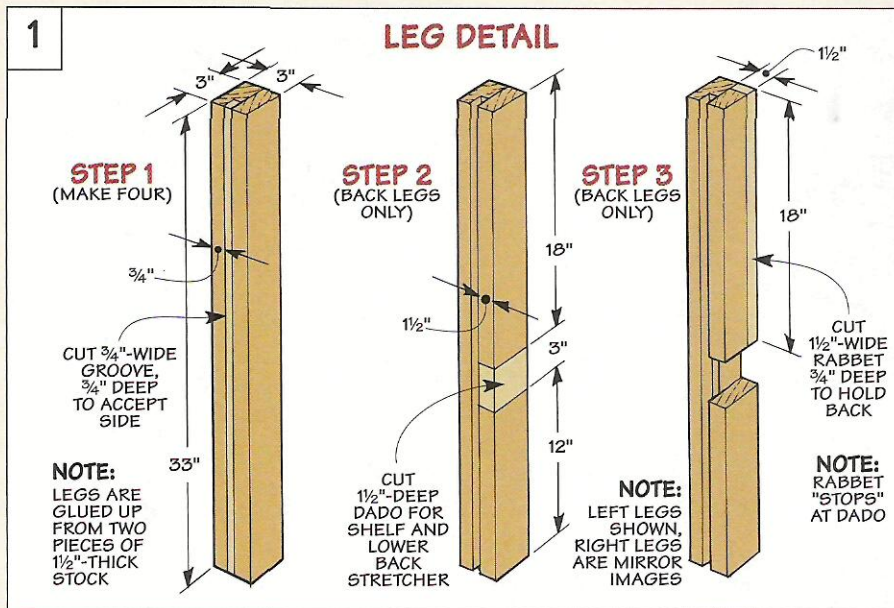

front stretchers, see Fig. 3. The *upper* (G) and *lower front stretchers* (H) are both cut to fit between the two end assemblies, so they're identical in length. And this time, they're the same width. Only here, the lower stretcher is rabbeted on the top inside edge to accept the shelf, see Fig. 3b.

As before, there's a groove in each of these stretchers to hold the rails, see Figs. 3a and 3b. But what's different is the ends of the stretchers are rabbeted to fit around the legs. This way, the shoulders of the rabbets will help prevent the front of the bench from racking. Since the stretchers are quite long, I routed these rabbets using a simple jig, see page 28.

RAILS. After screwing the front stretchers in place, the next step is to add the *rails* (I), see drawing. There are seven rails altogether. The three rails that bridge the upper stretchers help support the top. And the four rails that span the lower stretchers prevent the shelf from sagging when it's loaded with tools and supplies.

The rails are designed to fit into the stretchers with a simple tongue and groove joint. The grooves are already cut in the stretchers. So all that's needed is to rabbet the end of each rail to form the tongue, see

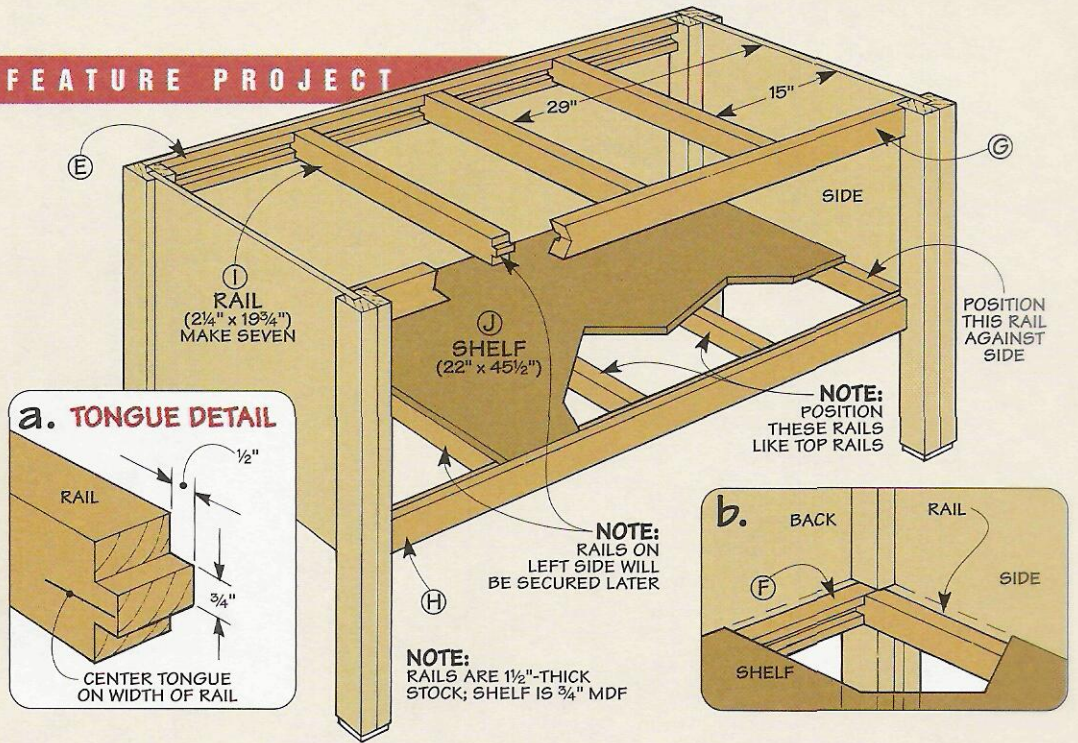

detail 'a' in the drawing above.

Now it's just a matter of installing the rails. What works well here is to start by first setting the rails in *rough* position. (You'll need to angle the rails slightly to slip the tongues into the grooves.)

Eventually, all the rails will be glued in place. But don't glue in the top and bottom rails on the *left* side of the bench yet. It's best to wait until after a slide panel is added later.

It doesn't take much glue to secure the other rails. Just mark the

final position of the rails and apply a small amount of glue in the groove. Then simply slide the rails into place.

SHELF. All that's left to complete the base is to add the *shelf* (J). It's just a piece of 3/4" MDF that rests on the lower stretchers and rails, see drawing above.

Since the MDF is quite heavy, you don't need to secure the shelf. Just slide it into position so the shelf fills the exposed part of the dado in the back leg and butts against the side, see detail 'b' above.

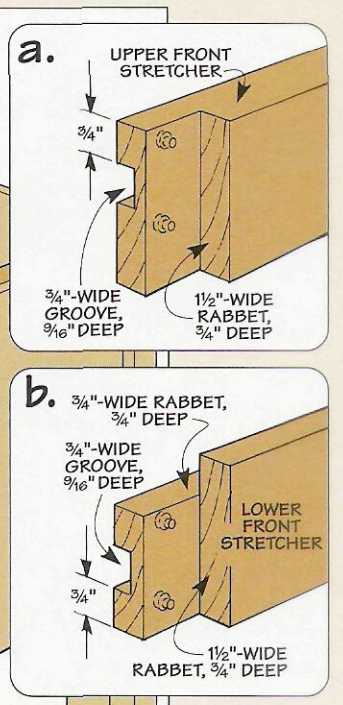
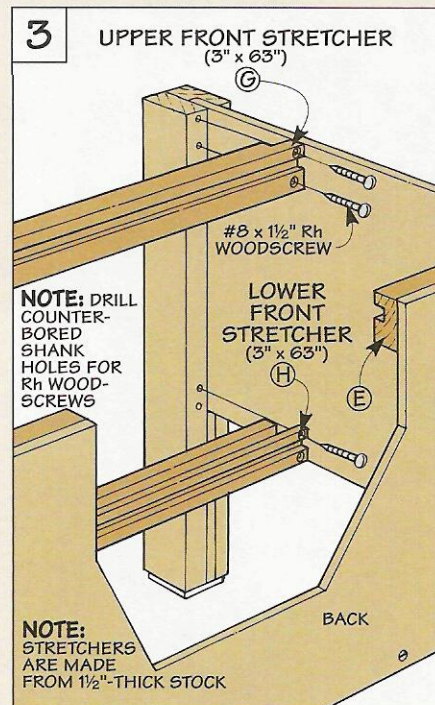
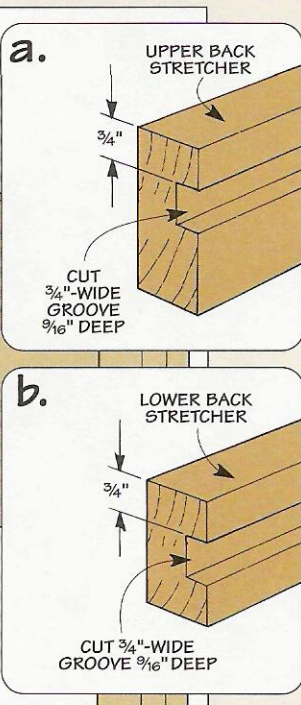
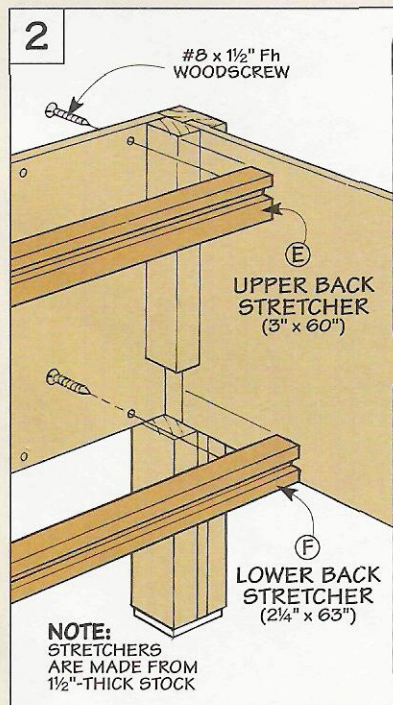

Drawers

To provide plenty of storage space, there's a bank of three drawers on the left side of the bench, see drawing at right. But I didn't start building them right away. First, I had to install a couple of large, flat panels to mount the drawer hardware.

LEFT SLIDE PANEL. I began with the *left slide panel* (K), see Fig. 4. It's a piece of $\frac{3}{4}$ " MDF that's cut to fit between the front and back legs. To fit the panel around the stretcher, you'll need to notch the upper front corner.

MOUNT SLIDES. After cutting the notch, I mounted the drawer slides. It's easier to do this now than having to reach inside the bench to do it later on. (To locate the slides, refer to Front View in the drawing at right.)

Before installing the panel, there's one thing to be aware of. The panel has to be flush with the *inside* face of the leg. Otherwise, when you open the drawers, they'll hit the leg.

SPACERS. To shim out the panel, I added two *spacers* (L), see Fig. 4. These are strips of $\frac{3}{4}$ " MDF that are sandwiched between the panel and the side of the bench.

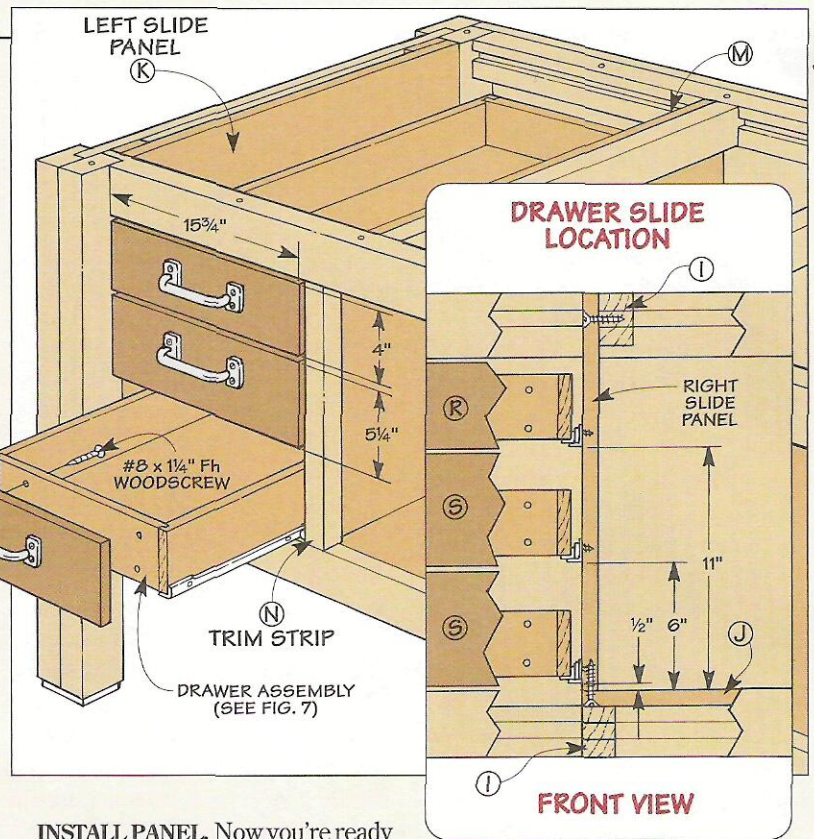

INSTALL PANEL. Now you're ready to install the slide panel (and spacers). The trick is keeping these pieces from shifting out of alignment while you attach them to the side of the bench. This is especially important with the slide panel. To prevent the drawers from binding, the slides on this panel

need to align with the slides on the right panel that's added next.

To accomplish this, I cut a scrap of $\frac{3}{4}$ " MDF and used it as a temporary support to position the spacers and left slide panel, see Fig. 4. After

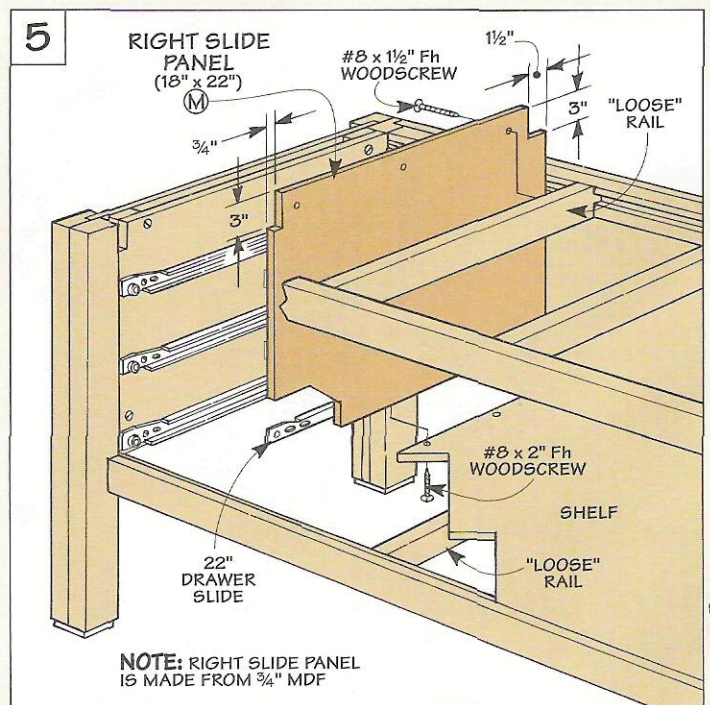
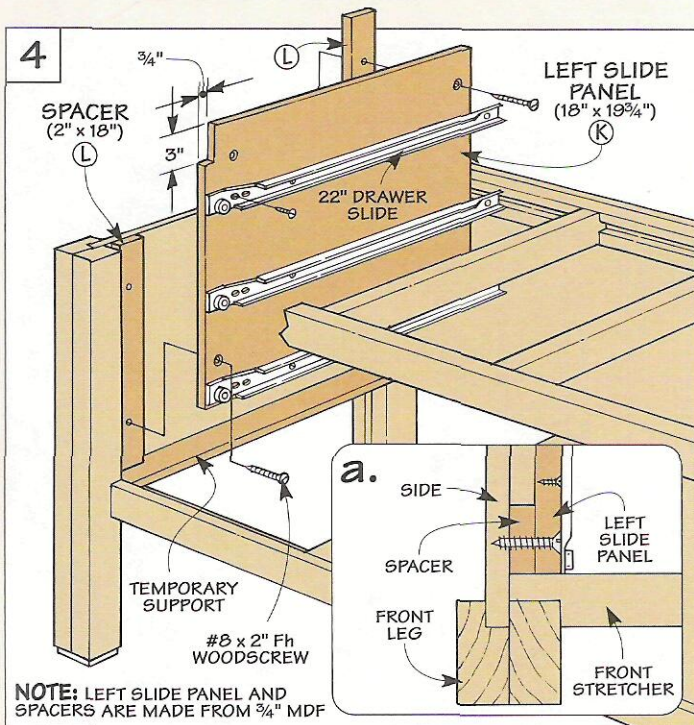

securing the panel (and spacers) with screws, just remove the support.

RIGHT SLIDE PANEL. Now you can turn your attention to the *right slide panel (M)*, see Fig. 5. It's the same height as the left slide panel. But it extends to the back of the bench, so it's longer. This means you'll need to notch *both* of the upper corners on this panel. Here again, it's best to mount the drawer slides before installing the panel.

The bottom edge of this panel is secured by driving screws up through the shelf, see Front View on top of page 20. (To do this, you may need to slide the "loose" rail on the bottom out of the way.) Then just glue this rail in its permanent location.

To anchor the top part of the panel, I used a similar process. Start by checking that the panel is square to the shelf. Then glue the upper rail (the second loose rail) in place so it butts against the panel. When the glue dries, screw the panel to the rail.

TRIM STRIP. There's one last thing to do before making the drawers. That's to add a *trim strip (N)* that covers the exposed edge of the right slide panel, see Fig. 6. It's a piece of 1½"-square stock (fir) that's rabbeted to fit the corner of the

panel and then glued in place, see Fig. 6a.

DRAWERS

At this point, the groundwork for the drawers is complete. Now you can build the drawers to fit the opening in the bench.

To keep things simple, all three drawers are identical in size. (One of the false fronts is smaller, but more about that later.)

DRAWER SIZE. There are several things to consider when sizing the drawers. First, the slides I used required a ½" clearance on each side. So the drawers are 15" wide (1" narrower than the opening). As for length, I made the drawers 22" long.

The type of joinery also plays a part in the length of the drawer pieces. For these drawers, I used a locking rabbet joint. It's a simple joint, yet it provides plenty of strength.

Once you've established the overall size of the drawers, cutting the pieces is just a matter of repetition. Start by cutting the *fronts/back (O)* and *sides (P)* to final size, see Fig. 7. (I used ¾"-thick pine.)

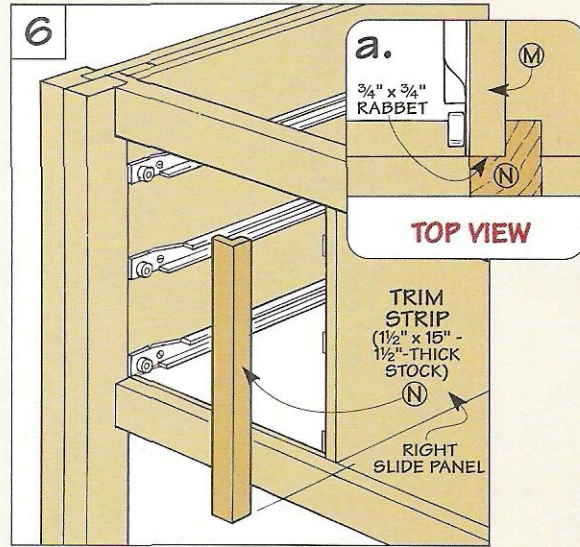

LOCKING RABBETS. Now it's time to cut the locking rabbet joints. To keep the drawers from pulling apart, tongues on the ends of the front and back fit into dadoes in the sides, see Fig. 7a. What works best is to cut the dadoes first. Then sneak up on the thickness of the tongues by rabbeting the front and back pieces.

CUT GROOVES. Before assembling the drawers, you'll need to cut a groove near the bottom of each piece to hold a ½" plywood *bottom (Q)*, see Fig. 7. Then dry assemble the drawers to make sure the pieces fit.

SLIDES. After gluing and clamping the drawers together, you can mount the other half of the drawer slides. They simply wrap around the bottom edge of the sides. Now slide the drawers into the bench. This will make it easy to position the false fronts that are added next.

FALSE FRONTS. The false fronts are pieces of ¾" MDF that are attached to the front of each drawer, see Fig. 7. One thing to note is they're not all the same size. I added a *narrow false front (R)* to the top drawer and two *wide false fronts (S)* to the two lower drawers, see drawing on page 20.

These pieces are sized to allow an ⅛" gap all the way around. After positioning the false fronts on the drawers, they're simply screwed in place. Finally, I mounted a heavy-duty pull to each drawer.

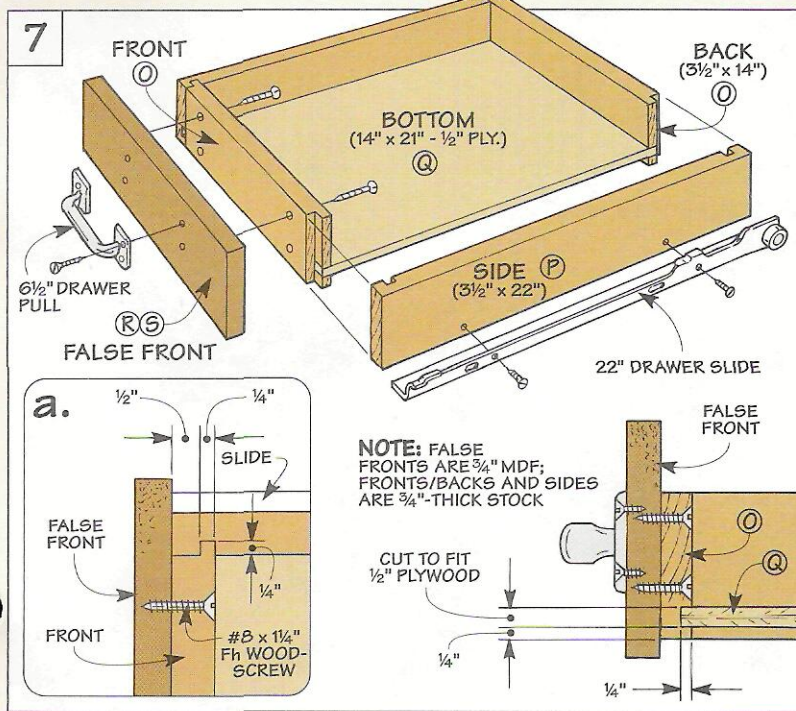

Bench Top

The most noticeable thing about this bench top is its metal cover. But what you don't see is what's *underneath* the cover — a large *top piece* made from $\frac{3}{4}$ " MDF, see Fig. 8. It's this top piece that ensures a flat, stable work-surface that won't warp or twist with changes in humidity.

METAL COVER. But before cutting the top piece to size, it's best to have the metal cover in hand. Making this cover should be a routine process for a heating and air conditioning company. All you'll need to provide are the gauge (thickness) of the metal and the final size of the top piece. (My cover is made from 24 gauge metal and is sized to fit a $26\frac{3}{4}$ " x 68" top.)

FOLDED EDGES. To avoid getting cut on a ragged burr (and to add rigidity to the metal), the edges of the cover are first folded underneath, see Fig. 8a. Then these double-thick edges are bent at a 90° angle.

TOP PIECE. Once you have the cover back in the shop, you can cut the *top piece* (T) to size. To "ease" the fit, I cut it $\frac{1}{8}$ " smaller than the *inside* dimensions of the cover. Also,

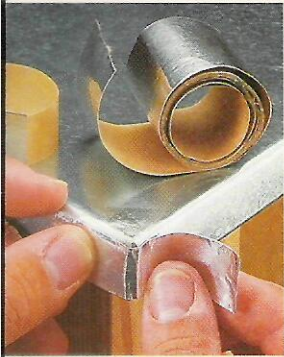
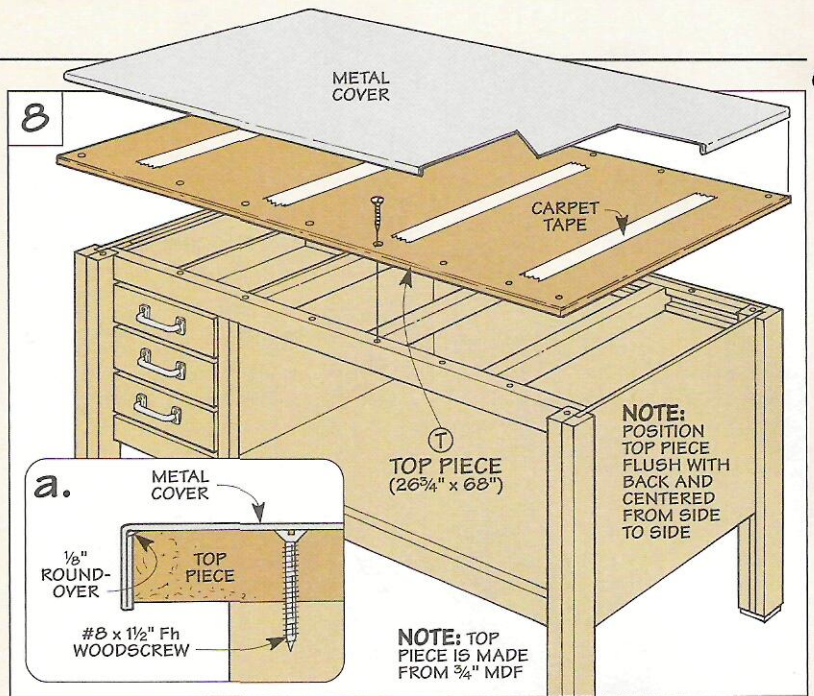

A quick way to cover the sharp edge at each corner of the cover is to stick on a small strip of aluminum tape.

rounding over the top edges and softening the corners allows the cover to fit down over the top piece without wrinkling the metal.

Before attaching the cover, you'll need to screw the top piece to the bench. Then simply secure the cover with strips of carpet tape to keep it from lifting off the top piece.

CORNERS. Finally, the corners of the cover still need some attention. That's because there's a "flap" at each corner with an exposed edge that's quite sharp. You can cover this edge with aluminum tape, see margin. Or for a more permanent solution, you may want to solder the corners, see the box below.

Soldering the Corners

It only takes a few minutes to solder the "flaps" on the corners of the metal cover.

SURFACE PREPARATION. To ensure a strong bond, the surface needs to be clean. But often, there's a greasy film on the metal. A bit of work with silicon-carbide sandpaper quickly removes the film.

FLUX. The next step is to brush a thin layer of flux across the joint, see photo below left. The flux will make the solder flow smoothly into the joint.

HEAT METAL. After applying the flux, sweep a propane torch back and forth until the metal is hot, see center photo.

SOLDER CORNER. You'll know it's hot enough when you hold the solder against the metal and it begins to melt, see photo below right. Ideally, the solder should run evenly along the joint line. But most likely there will be some small gobs of solder that will need to be filed smooth.

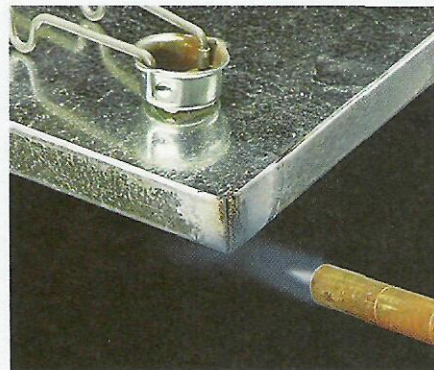
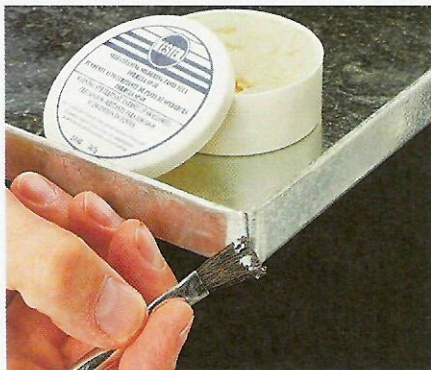

Storage Unit

As an option, you may want to add a simple storage unit that sits on top of the bench, see photo at right. The storage unit is a handy way to store a few supplies or to organize small pieces of hardware.

BINS. To hold the hardware, I used a number of plastic bins. It's best to purchase these bins *before* you get started. This will make it easy to determine the overall size of the storage unit.

Note: I bought plastic storage bins at a local home center. They're also available from the mail-order sources listed in the margin.

CONSTRUCTION. There's nothing complicated about the storage unit. It starts out as a pair of *end pieces* (U) and two *shelves* (V) made from 3/4" MDF, see Fig. 9. (I had pieces left over from the workbench.)

The shelves fit in dadoes near the top of the end pieces, see Fig. 9b. So when locating these dadoes, be sure there's enough clearance for the bins to slide in and out.

Before assembling the storage unit, you'll need to cut a rabbet in the back edge of each shelf, see Fig. 9a. This rabbet will accept a hardboard back that's added later.

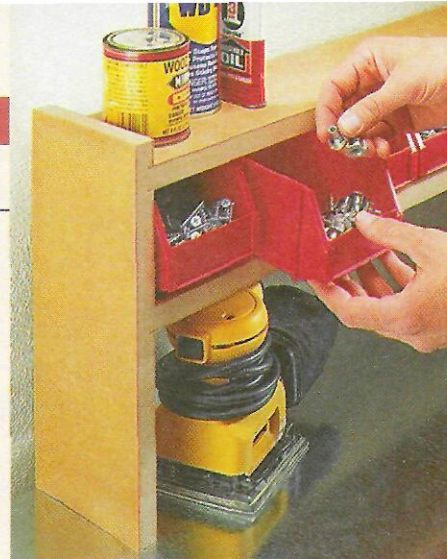

ASSEMBLY. Now you're ready to assemble the storage unit. This is just a matter of gluing and clamping the shelves and end pieces together.

BACK. When the glue dries, it's time to add the *back* (W), see Fig. 9. It keeps the bins from sliding out the back of the storage unit. But more important, it adds rigidity that prevents the unit from racking. The back is a narrow strip of 1/4" hardboard that's cut to fit the opening between the shelves. Here again, it's simply glued and clamped in place.

APPLY FINISH. All that's left to complete the storage unit (and the workbench) is to apply a finish. To provide plenty of protection against dirt and moisture, I brushed on three coats of polyurethane.

Of course, there were the usual drips and spills. But it didn't matter much — they landed on the metal cover, so I just wiped them off. 🛠️

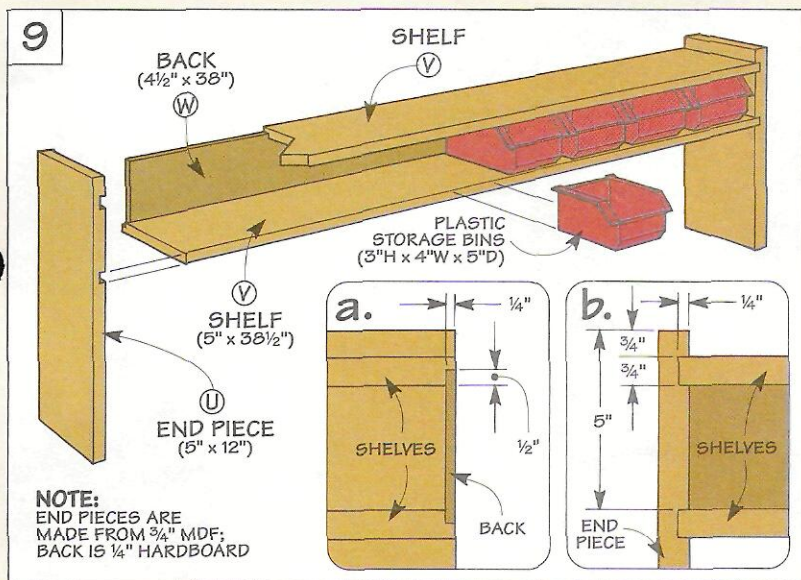

Sources

• Mail-order sources for plastic storage bins are listed below:

Rand
800-366-2300
McFeeley's
800-847-7136

Accessories

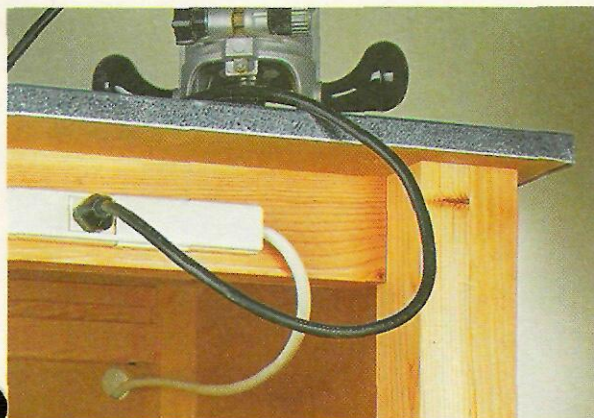

▲ **Power Strip.** To provide a convenient plug-in for my portable tools, I attached a power strip to the bench. The power cord for the strip feeds out a hole in back.



▲ **Mounting Pads.** A double layer of MDF provides a solid mounting pad for a vise (or grinder). Clamping the pad to the metal cover holds the tool securely in place.

Roll-Around Clamp Cart

Simple hangers make it easy to customize this cart to hold all your clamps.

One of the guys told me that this clamp cart reminded him of a Christmas tree — big and green, with stuff hanging all over.

Well, the more I thought about that, the more it made sense. After all, it's what you hang on a tree that makes it special, not the tree itself.

That same idea is true for this clamp cart as well. The "tree" is just a large, H-shaped box on wheels. Then it's "decorated" by hanging clamps on the front, back, and sides of the cart, see photos above.

One big advantage to storing clamps on a cart like this is you don't

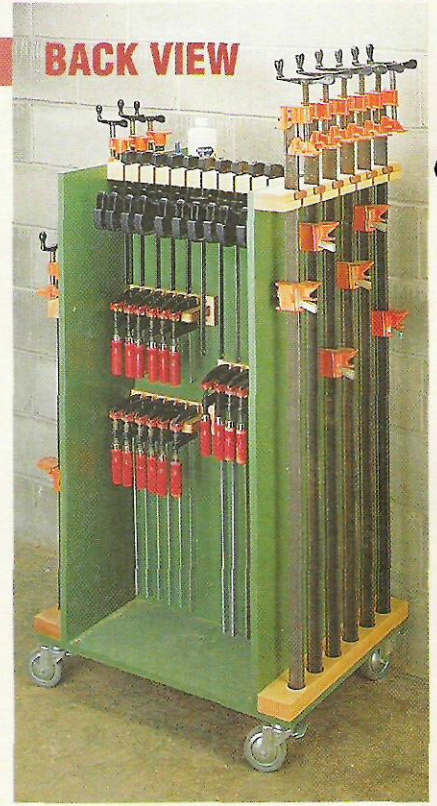
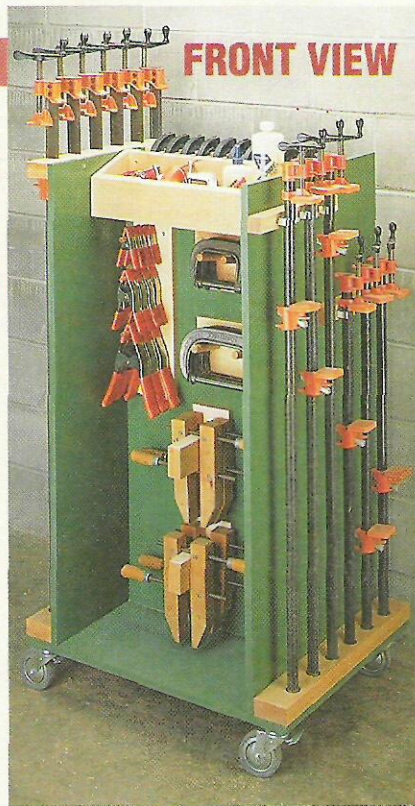

EXPLODED VIEW
OVERALL DIMENSIONS:
(31" W x 24" D x 53" H)

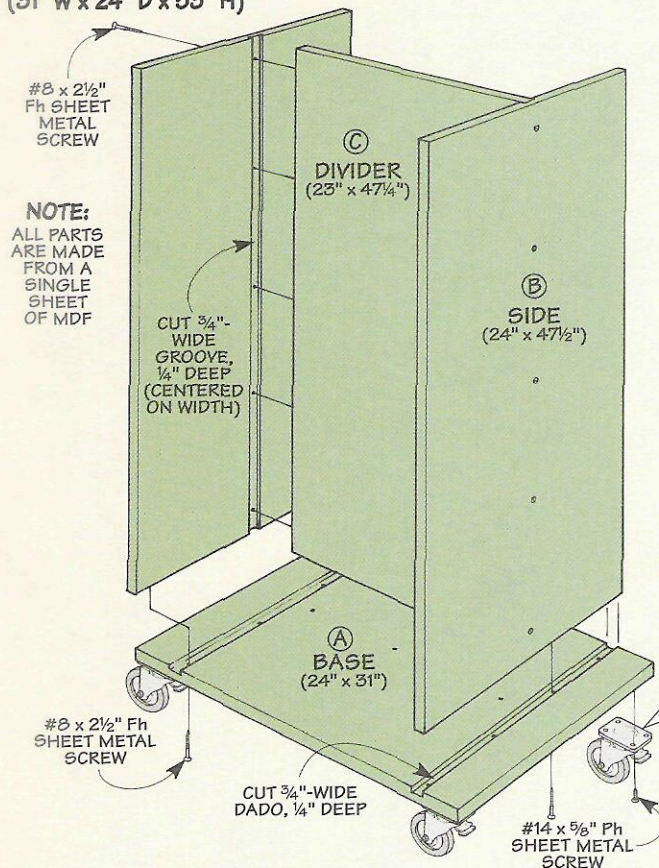

have to lug them back and forth across the shop. Just "park" the cart right next to where you're working. Then grab the clamps needed for that particular job and hang them back up once you're done.

HANGERS. The clamps are held securely in place by *hangers* that are mounted to the cart. Each hanger is designed to fit a certain *type* of clamp. This keeps the clamps from falling off the cart as you roll it around. The hangers also make it easy to remove a clamp (or put it back) without a lot of fussing around.

Since I have a variety of clamps, I made a number of different hangers. They hold everything from wood handscrews and lightweight spring clamps to my bar clamps and heavy I-beam clamps. I even added an open bin to hold glue-up supplies. (There's

more detailed information about each hanger in the rest of the article.)

CUSTOMIZE CART. The nice thing about all this is it's easy to customize the cart. Just make the appropriate number (and type) of hangers for the clamps in your shop. Then mount the hangers on the cart.

CART

The cart itself has a simple, straightforward design. In fact, there are only four pieces — all made from a single sheet of 3/4" MDF.

CONSTRUCTION. I began by cutting the *base* (A) of the cart to final size, see drawing at left. There's a dado near each end of the base that makes it easy to align the *sides* (B), see detail. And a centered groove in each side accepts a *divider* (C) that separates the front and back of the cart.

ASSEMBLY. To help simplify the assembly (and strengthen the cart), the pieces are assembled with glue and screws. (I used sheet metal screws because the straight shanks won't split the MDF like the tapered shanks on standard woodscrews.)

After completing the assembly, I spray painted the cart. Then I turned it upside down and mounted four locking swivel casters, see detail 'a'.

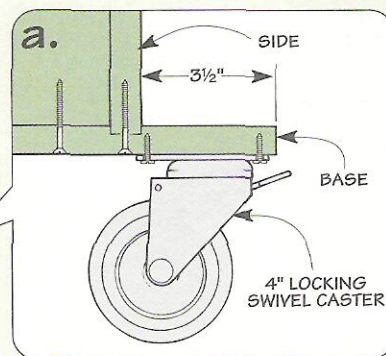

Quick Clamps

Over the last few years, I've purchased a number of "quick clamps" (the kind that have a pistol grip for one-handed use). The fixed jaw on these clamps is *curved*, and that's what gave me the idea for this hanger.

The curved jaw hooks over a lip on the front edge of the hanger, see photo. This lip is formed by gluing a narrow *cleat* onto a wide *base* piece.

To accept the bars of the clamps, you'll need to cut slots in the front edge of the hanger. Then just screw the hanger to the divider, see detail.

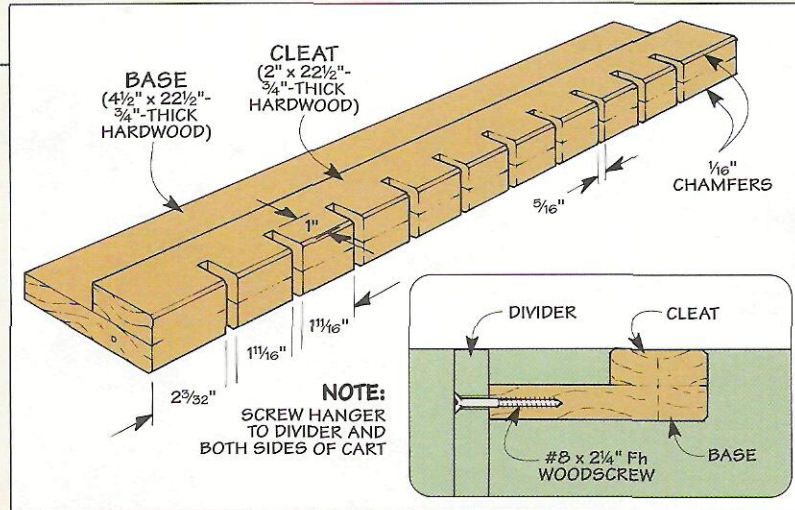

▲ To hold this quick clamp in place, the curved jaw hooks over a lip on the hanger.

Bar Clamps

There's no question about it — I use my bar clamps more than any other clamps in the shop. That's why I like this hanger. It has a number of long slots that let me slip the clamps in or out in a matter of seconds, see photo.

The hanger consists of two parts: a *mounting plate* that attaches to the cart and a slotted *support block* that holds the heads of the clamps.

SUPPORT BLOCK. The support block is made up of a hardwood *core piece* that's sandwiched between a hardboard *top* and *bottom*, see drawing.

Gluing up a layer cake like this strengthens the "fingers" that are formed when you cut the slots. This way, the narrow fingers won't break off when they get bumped or banged by one of the clamps.

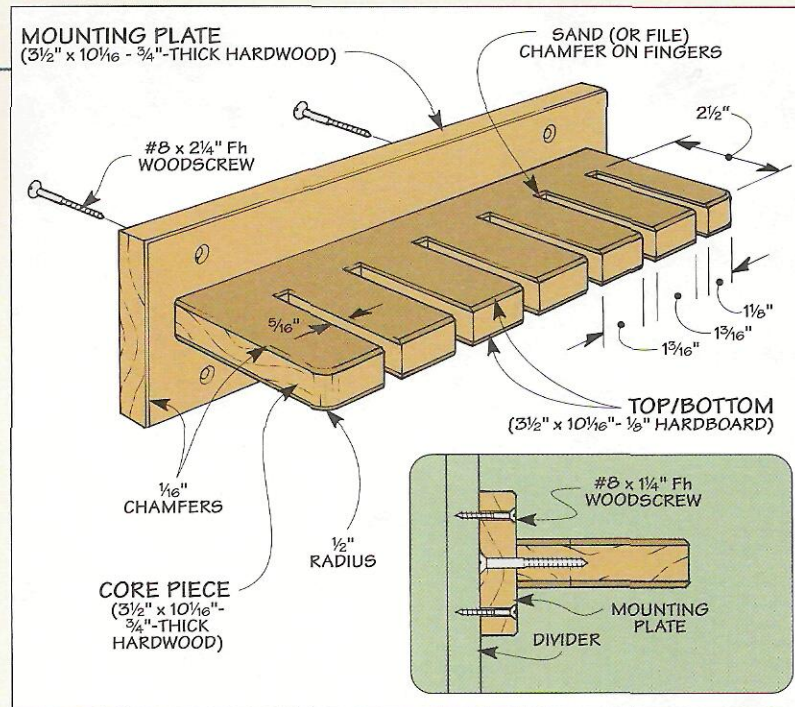

▲ The long slots in this hanger make it easy to slip bar clamps in and out.

Handscrews

It's hard to imagine a simpler way to hold handscrews than this T-shaped hanger, see photo.

The handscrews fit onto a thick, glued up *support block*, see drawing. It's sized to fit between the threaded rods on the handscrews. (I made the block to fit 10" handscrews.)

As with the bar clamp hanger, the support block is screwed to a hardwood mounting plate, see detail. (To strengthen the block, I used 3"-long screws.) Then simply screw the mounting plate to the divider.

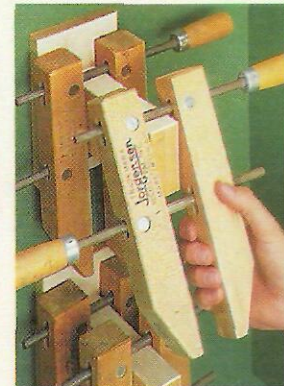
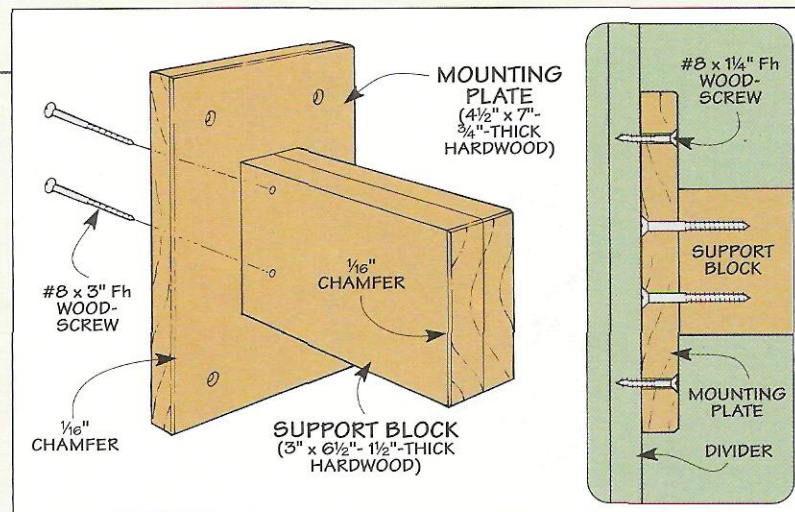

▲ All it takes to hold handscrews is a simple wood block.

I-Beam Clamps

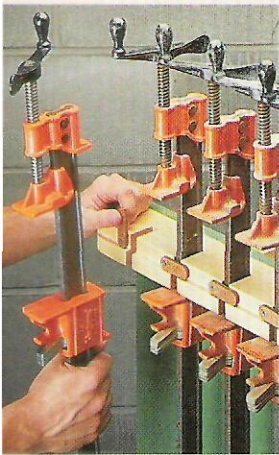

▲ To remove one of these heavy I-beam clamps, just flip up a turnbutton. Then flip it down to lock the clamp in the hanger.

Storing I-beam clamps is a challenge. They're heavy and awkward to carry. So I built a sturdy hanger that holds the clamps securely, yet still makes it easy to lift them in and out.

This hanger consists of two parts: an *upper* and *lower rail*, see drawing. To set a clamp in place, just stick the bottom end in a "pocket" in the lower rail. Then slip the I-beam into a slot in the top rail and lock it with a turnbutton, see photo.

The rails are identical in length. But because of the large holes in the lower rail, it needed to be a bit wider. Both rails are made by gluing up two pieces of 3/4"-thick hardwood.

LOWER RAIL. Once the glue dries, you can drill the large holes in the lower rail. I also routed a chamfer around the rim of each hole. This helps me quickly "find" the holes when I'm putting clamps away.

UPPER RAIL. Now you can turn your attention to the upper rail. It's rabbeted along the front edge to form a lip for the turnbuttons. The lip acts as a "stop" that prevents the turnbuttons from accidentally pivoting down (out of the locking position).

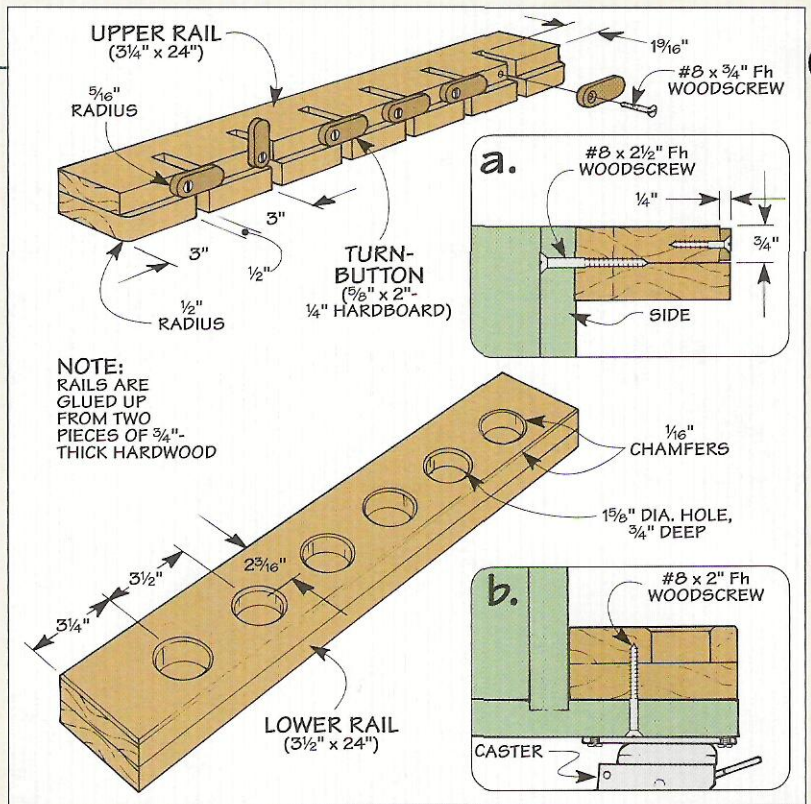

The next step is to cut a series of open slots in the front edge. These slots are sized so the I-beams fit snug when the turnbuttons are closed.

TURNBUTTONS. At this point, you can add the turnbuttons. These are

pieces of 1/4" hardboard with a radius sanded on each end. A single screw holds each one in place.

MOUNT HANGER. All that's left is to screw the rails to the sides of the cart, see details 'a' and 'b.'

Pipe Clamps



▲ A spring steel clip securely grips each of these pipe clamps. But a quick tug is all it takes to release the clamp.

The hanger for my pipe clamps is similar to the I-beam hanger. But here, a metal clip grips the clamp and holds it in place, see photo at left.

Once again, the bottom ends of the clamps fit in holes drilled in a thick *lower rail*, see drawing. But the pipes aren't as big around as the I-beam clamps, so I drilled smaller holes. As before, the lower rail is just screwed to the base of the cart, see detail 'b.'

Since my pipe clamps are different lengths, I made two *upper rails*. To hold 24"-long clamps, I mounted one rail about halfway up the sides of the cart, see detail 'a.' The other is closer to the top to hold my 48" clamps.

Now it's just a matter of adding the metal clips. I used ordinary broom clips made of spring steel. (These are available at most hardware stores.)

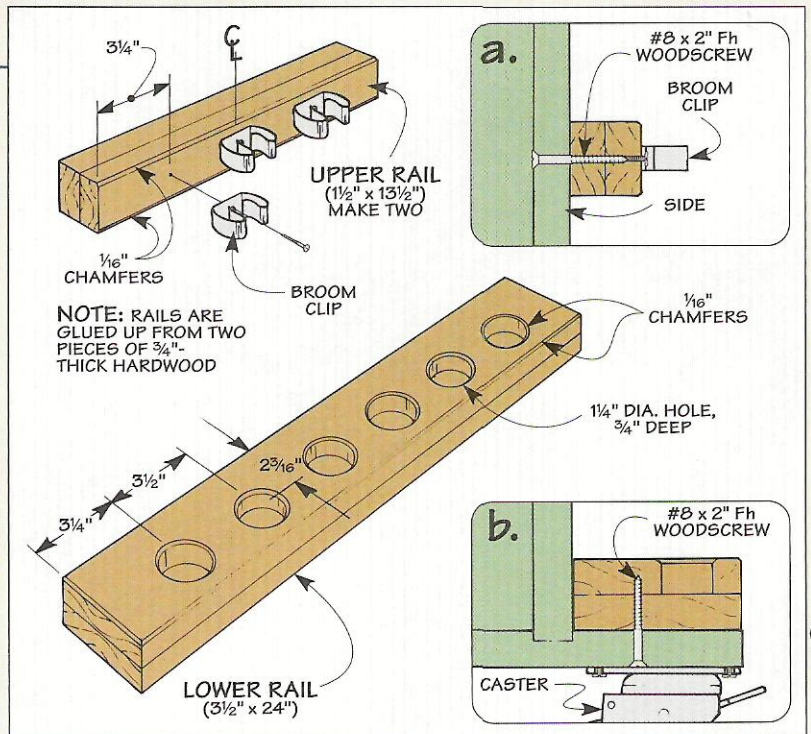

Spring Clamps

It's hard to imagine a simpler way to hold spring clamps than this hanger, see photo. The clamps hang from *pegs* that are glued into holes in a hard-wood *mounting plate*, see drawing.

To make the most efficient use of the space, I located the pegs so that the smaller spring clamps "nest" over the large clamps.

Also, my clamps have rubber tips that keep them from slipping off the pegs. So I drilled straight holes for the pegs. For metal-tipped clamps, it's a good idea to drill angled holes.

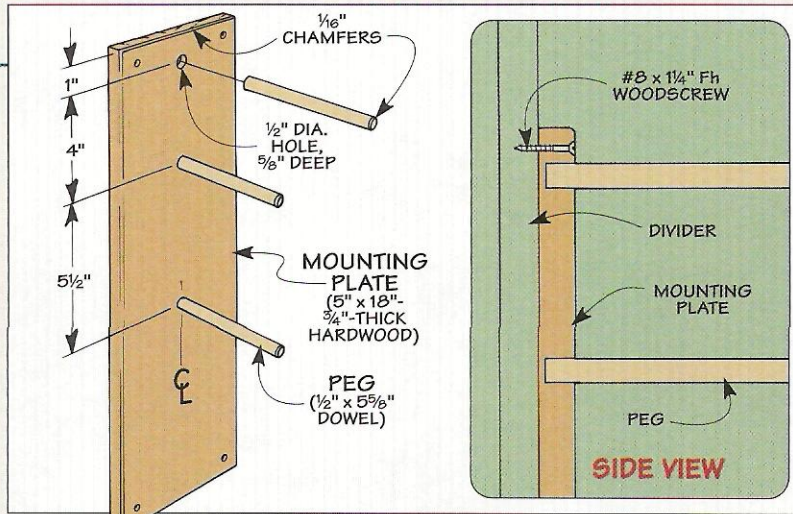

▲ Just slip your spring clamps on and off the wood pegs on this hanger.

C-Clamps

To hold my C-clamps, I used the same basic idea — a couple of *pegs* and a *mounting plate*, see drawing.

The nice thing about this hanger is I can slip the clamps on and off the pegs without having to open and close the clamps, see photo.

Because the C-clamps are heavier, I used larger dowels. And here, it's best to drill *angled* holes to keep the clamps from sliding off.

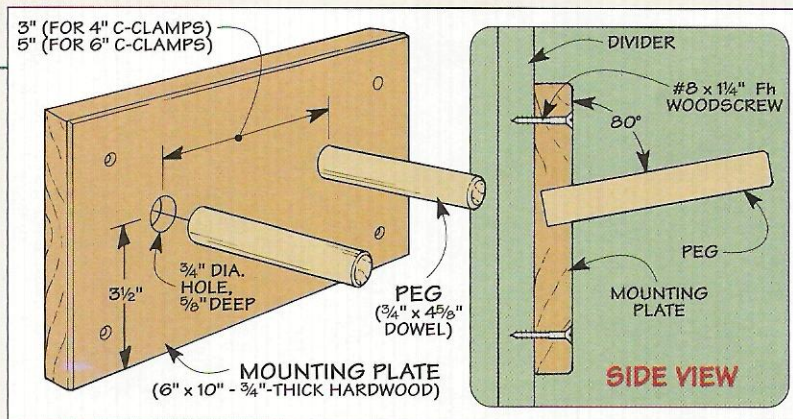

▲ Two pegs provide a handy solution to an old problem — storing C-clamps.

Storage Bin

I still needed a "home" for a few odd-shaped clamps (like my band clamps and toggle clamps). Plus, I wanted a place to put glue bottles, brushes, and all my other glue-up supplies.

To provide a handy storage place for these things, I added a simple bin, see photo. Basically, it's a long, narrow box with tapered ends, see drawing. This wedge-shaped design makes it easy to see what's inside the bin, reach in, and grab what I need.

There's nothing complicated about the bin. The *ends* are rabbeted to accept a narrow *front* and a wide *back* piece, see detail 'a.' And there's a groove in each piece to accept a hardboard bottom, see detail 'b.'

Now it's just a matter of mitering both ends at an angle and beveling the front to match. After assembling the bin with glue and screws, simply screw the bin to the cart.

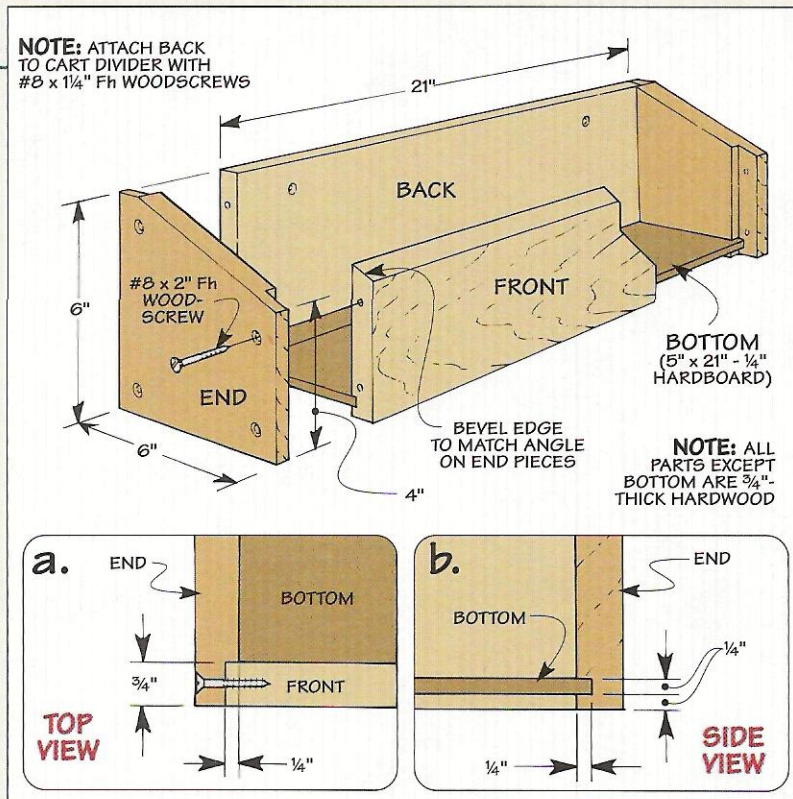

▲ Use this open bin to store your odd-shaped clamps and glue-up supplies.

RABBETING THE END OF A LONG PIECE

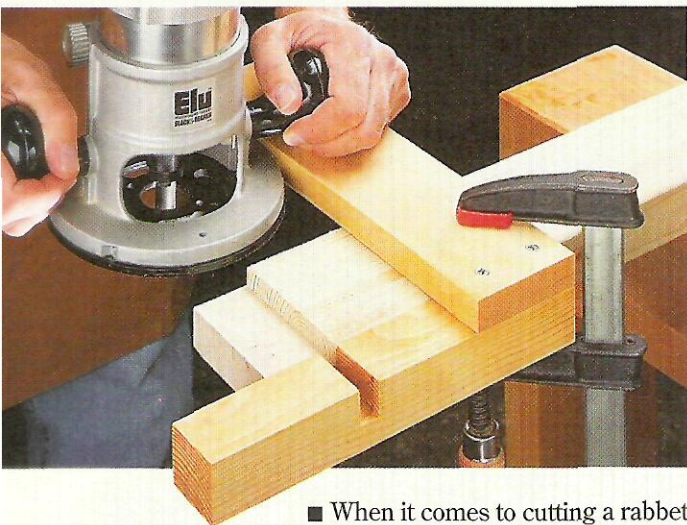

■ When it comes to cutting a rabbet on the end of a workpiece, I usually use the table saw. But holding a *long* workpiece tightly against the miter gauge while making the cut can be a challenge. Especially when the workpiece is over five feet long (like the stretchers on the Utility Workbench shown on page 16).

GUIDE. To solve this problem, I made an L-shaped guide to use with a handheld router and straight bit, see photo above.

The guide consists of two parts: a *fence* to guide the router and a *cleat* that keeps the fence square to the edge of a workpiece, see drawing.

ANGLED HOLES

■ Drilling an angled hole isn't a tough task. Just tilt the drill press table to the desired angle and drill the hole. But *resetting* the table to a position that's square to the bit can take some time.

To get around this, I use an angled platform that clamps to the table of my drill press, see photo. This came in handy when drilling the angled holes in the hangers for the Clamp Cart shown on page 24.

PLATFORM. The platform starts out as a *base* with a beveled *support* that positions it at the proper angle, see drawing. (In my case, this was 10°.) A *stop* along the bottom edge of the base prevents the workpiece from slipping off the platform as you drill the hole.

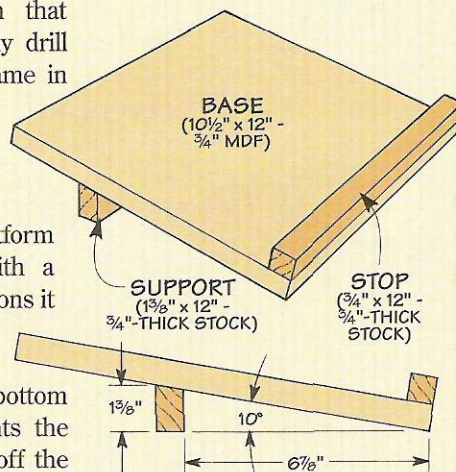
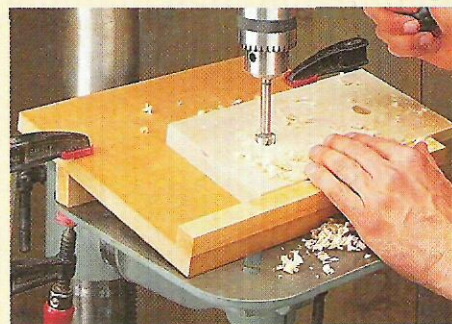

The fence is just a scrap of 3/4"-thick stock. But the cleat is made from a 1 1/2"-thick piece of scrap. The reason for this is simple.

REFERENCE NOTCH. Using a thicker piece of stock for the cleat allows you to create a deep reference notch when you make the first pass with the router. This reference notch helps to align the guide when you

make the remaining passes.

ASSEMBLY GUIDE. It's important for the shoulder of the rabbet to be square with the edge of the workpiece. So before screwing the fence to the cleat, use a square to accurately align both parts.

ADJUST BIT. Now you're ready to rout the rabbet. Start by installing a 1/2" straight bit in your router and adjusting the depth of cut. For the rabbets at the ends of the stretchers on the workbench, I set the bit for a full depth cut and nibbled away 1/4" of material at a time, see Side View.

ROUT RABBET. With the guide clamped in place, you can begin cutting the rabbet. After the first pass, slide the guide along the workpiece (about 1/4" at a time) using the reference notch to position the guide. Note: For the final pass, align the inside edge of the reference notch with the layout line that defines the shoulder of the rabbet.

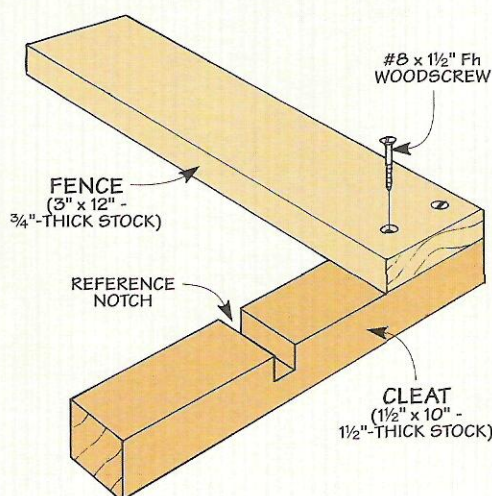
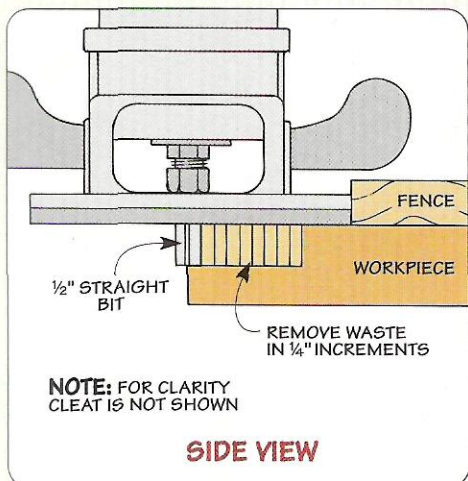

CUTTING & SANDING CIRCLES

■ Cutting the seat and collar for the Shop Stool (page 6) is easy. All it takes is a band saw and a simple jig, see top photo at right. As an added benefit, you can use the same jig to sand the disks smooth on a disk sander, see lower photo.

JIG. The jig consists of four parts: a *base* made from MDF, a hardwood *runner*, a short dowel used as a *pivot pin*, and a small screw that acts as a *stop*, see Fig. 1.

To fit the runner, I cut a groove along one side of the base. Cutting the groove to one side allows you to flip the base around later to accommodate the larger radius of the seat.

With the groove complete, I added a 1/2"-long screw a few inches from one end of the groove. This screw acts as a stop for the runner.

Finally, drill a hole at one end of the runner. Then glue in a short 1/4"-dia. dowel to act as a pivot pin for the workpiece.

SETUP. Setting up the jig is a simple process. The first step is to position the jig on the band saw table. To do this, set the runner in the groove and slide it against the stop. Then carpet-tape the base to the table so the center of the pivot pin is directly across from the leading edge of the blade, see Figs. 1 and 1a. Note: The distance from the centerpoint of the pivot pin to the saw blade equals the desired radius of the disk.

CUT COLLAR. With the jig in place, pull the runner back and set

the hole in the collar over the pin. Then hold the blank securely as you slide the runner forward. When the runner contacts the stop, rotate the blank clockwise to cut the collar to final size. Once you've come full circle, slide the runner back and remove the collar.

CUT SEAT. To make the seat, simply repeat the process. Here, you'll need to turn the base around.

This places the groove farther from the blade of the band saw. This way, you can still carpet tape the base to the table of the band saw and allow for the larger radius of the seat. Note: You'll also need to move the screw to the other end of the groove.

Once you've turned the base around and carpet-taped it to the table, set the hole in the blank for the seat over the pivot pin and repeat the process.

SAND DISKS. After cutting both the seat and collar to size, you'll need to sand the edges smooth. To make quick work of this (and to end up with perfectly round workpieces), I used the same jig.

Setting up the jig to sand the edges is similar to cutting them to size on the band saw. Only you won't

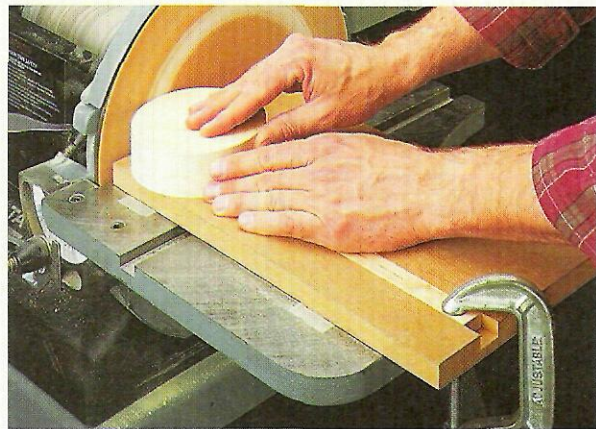
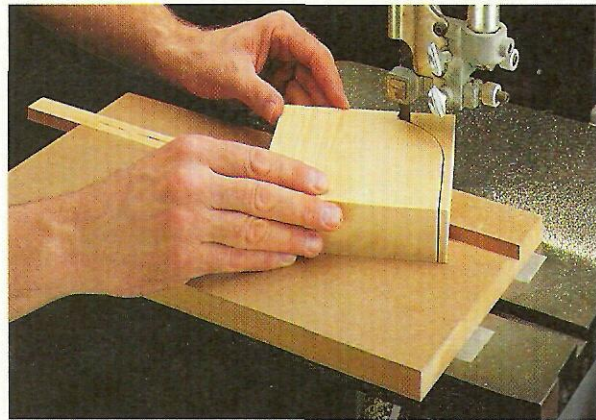

need a stop for the runner. Instead, the base of the jig is carpet taped to the table of the disk sander so the front edge is 1/16" away from the sanding disk, see photo above.

Then simply fit the workpiece over the pivot pin and slide the runner forward until the edge just contacts the spinning disk. At this point, clamp the runner in place and sand the disk by rotating it in a clockwise direction, see photo above.

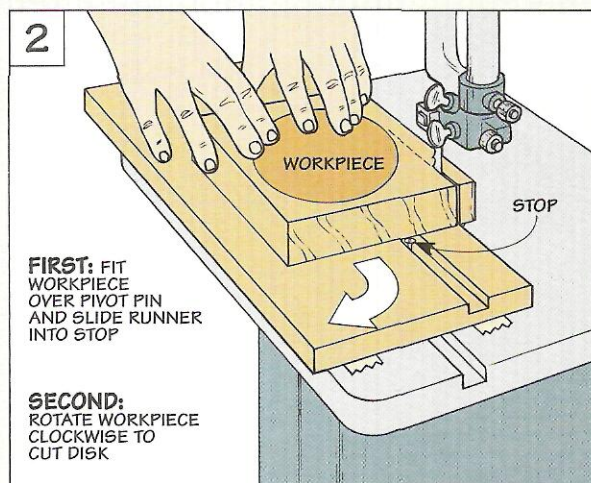
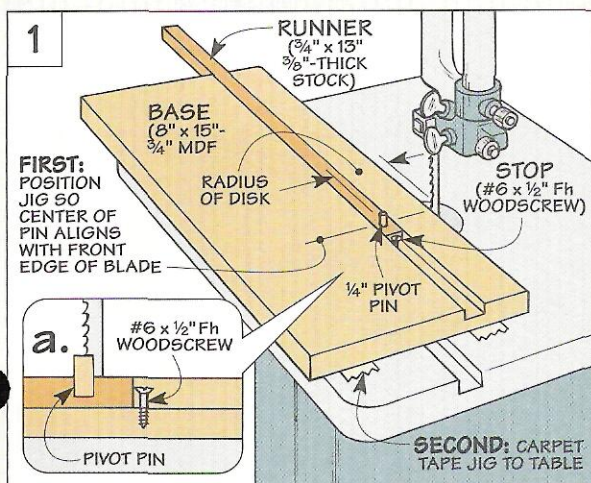

Tool Talk

TOOLS OF THE TRADE

Blade Stabilizers

■ One of the simplest ways to get a smoother cut from the blade on your table saw is to use a *blade stabilizer*. This is a flat, metal disk that slips onto the arbor of the saw and fits against the blade, see photo at right.

Note: Some stabilizers are sold in pairs (one on each side of the blade). But the stabilizer on the *inside* of the blade “throws off” the scale on the rip fence, so I prefer using a single blade stabilizer.

STIFFENS BLADE. So how does a stabilizer improve the quality of cut? First of all, it’s like a big, thick washer that helps “stiffen” the blade. (This is especially true for a thin-kerf blade.)

The extra mass of the stabilizer dampens the vibration set up by the motor, pulleys, and belts. Since there’s less vibration transferred to the blade, it runs “truer” and makes a cleaner cut.

FLAT & LEVEL. But a blade stabilizer isn’t just a hunk of metal. It’s ground flat and level on *both* sides. This way, when you tighten the arbor nut, it presses the stabilizer flat against the blade (like a kid pressing his face against a window). As a result, the stabilizer minimizes the “flutter” in the blade that can cause the wood fibers to fray.

REDUCES NOISE. There’s also a side benefit to using a blade stabilizer. Since the blade cuts cleanly through the air, it runs quieter. A stabilizer reduces the decibel reading of my saw from 93 to 90 dB. (That may not sound like much, but it means a decrease in the intensity of the sound by *half*.) Even so, 90 dB is still too loud to work

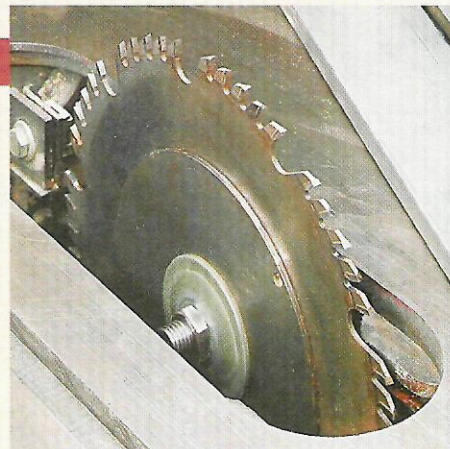

without hearing protectors.

SIZES. You’ll find that blade stabilizers come in a variety of sizes, see margin. As a rule, the more support, the better. So I’d recommend using the largest stabilizer possible.

The only drawback to this is it limits the maximum depth of cut you can make with your blade. But I don’t find that to be too much of a problem. To make a deeper cut, just remove the stabilizer.

SOURCES. Blade stabilizers are available from many woodworking stores and catalogs, see page 31.

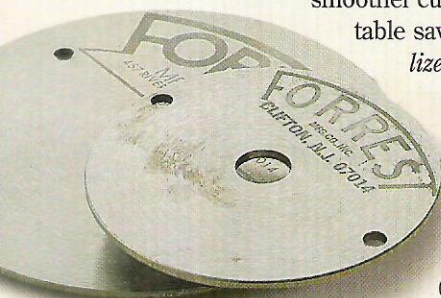

▲ The small 4" blade stabilizer (above) won't limit the depth of cut as much as the 6" stabilizer below it. But it doesn't provide as much support.

What about Extension Cords?

■ I never used to give extension cords much thought. That was my first mistake. The second was stringing together two lightweight cords to plug in my circular saw.

At first, the saw worked fine. But after awhile, I noticed the smell of burnt electrical parts. I quickly flipped the switch on to see if the saw was okay, but nothing happened. That’s when I got a sick feeling that the saw was ruined.

The sad thing is it could have been prevented by selecting the

correct extension cord.

AMPS. The best way to do this is to start by finding the amperage (current) needed for the tool to operate properly, see chart below left. (This information may be on the plate that’s on the motor as well.)

Once you know the amperage, the key is to use an extension cord that can “carry” the load. This is a combination of two things: the *gauge* and *length* of the cord.

GAUGE. The gauge refers to the size of wire in the cord. The *larger* the gauge, the *smaller* the wire. If the wire is too small, the current can’t flow easily. (It’s like trying to squeeze out a crowded exit door at the movie.) This can cause the extension cord to overheat or start a fire.

LENGTH. The second consideration is the length of the cord. As the length *increases*, the voltage *decreases*. (Voltage is what pushes

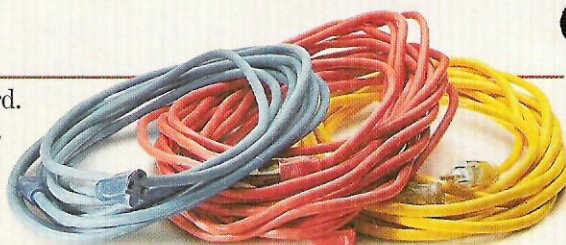

the current through the cord.) If the voltage is too low, the motor is “starved” of the power it needs. Since it’s not working efficiently, it gets hot and may burn up.

To prevent this, simply match the gauge and the length of the cord to the amperage required by the tool, see chart below.

Power Tool Amperages

Portable Tool	Tool Amperage
Circular Saw	13-15 Amps
2 HP Router	10-15 Amps
1 HP Router	5-10 Amps
1/2" Drill	6-8 Amps
Sabre Saw	5-6 Amps
Palm Sander	1.5-2 Amps

Wire Gauge & Length

Wire Gauge	50 Ft. Cord	100 Ft. Cord
10 Ga.	25 Amps	20 Amps
12 Ga.	20 Amps	15 Amps
14 Ga.	15 Amps	13 Amps
16 Ga.	13 Amps	10 Amps
18 Ga.	8 Amps	6 Amps

Sources

PRODUCT INFORMATION

Hardware & Supplies

To make it easy to round up the hardware and supplies that you'll need to build the projects featured in this issue, we've put together a number of convenient mail-order sources.



▲ Metal Worksurface

Adding a metal worksurface to the top of a bench (like the one shown on the Utility Workbench on page 16) makes it more durable and easy to clean.

The best source for a metal cover is your local heating and air conditioning company. The metal cover we had made cost about \$55.

All of the other materials for the Utility Workbench should be readily available from a lumberyard or home center.

Selecting the Right Dowels ▶

One of the secrets to cutting clean, crisp threads is selecting the right dowels. The only problem is that many store-bought dowels are slightly oversized or undersized, and this can result in uneven threads. Fortunately, you can get dowels that are closer to the "true" size from several of the companies listed in the margin.



Tap & Threadbox ▶

The article beginning on page 12 explains how to cut threads in wood. To cut these threads by hand, all that's needed are two simple tools: a tap and a threadbox.

These threading tools are available as a matched set in sizes ranging from 1/2" to 1 1/2" in diameter, see margin. (The size refers to the diameter of the dowel that can be threaded.) Most of these sets are available for about \$40.

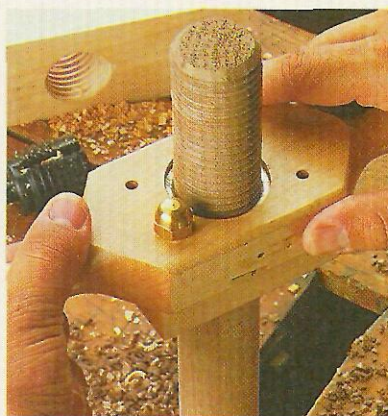

Beall Threading Kit ▶

A router and a threading jig provide a quick, accurate way to cut threads in a dowel. The jig we used is manufactured by the Beall Tool Company.

It's designed to cut threads in 1 1/2"-dia. dowels. But it's also available in 1/2", 5/8", 3/4", 1", and 1 1/4" sizes. A V-groove bit is included with the jig as well as a tap used to cut the inside threads. The 1 1/2"-dia. kit we bought cost \$92, see margin for a source.

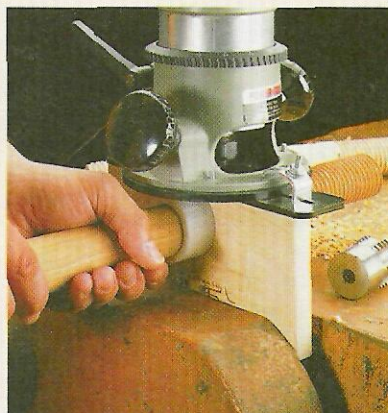

MAIL ORDER SOURCES

Beall Tool Co.
800-331-4718
*Router Threading Jig,
Hardwood Dowels*

Forrest Manufacturing
800-733-7111
Blade Stabilizers

Highland Hardware
800-241-6748
Tap & Threadbox

Lee Valley
800-871-8158
*Multi-Spur Bits,
Tap & Threadbox*

Woodcraft
800-225-1153
*Blade Stabilizers,
Multi-Spur bits,
Tap & Threadbox*

Woodworker's Supply
800-645-9292
*Multi-Spur Bits,
Hardwood Dowels*

◀ Multi-Spur Bits

Multi-Spur Bits are ideal for drilling large holes. (We used them when building the Shop Stool shown on page 6.) The "spurs" on this type of bit cut smooth, clean holes. And they don't heat up as much as the rim of a Forstner bit, see margin for sources. Note: These bits are sometimes referred to as Saw Tooth bits.



NOW ON THE WEB!

WoodNet

- 101 Woodworking Tips Online
- Woodworking Techniques — Step-by-Step
- Project plans you can download
- WoodNet Forum — Woodworkers' Q & A
- Power Tool Reviews

Point your browser to: <http://www.augusthome.com>
Select "Woodworking" from the Welcome Page menu.

ON-LINE CUSTOMER SERVICE

- Access information about your subscription account.
- Find out if your payment has been received.
- Change your mailing address or your e-mail address.
- Let us know if you haven't received your issue.

www.shopnotes.com

TO PLACE AN ORDER CALL

800-347-5105

(KEY CODE: SN 46)

Scenes from the Shop

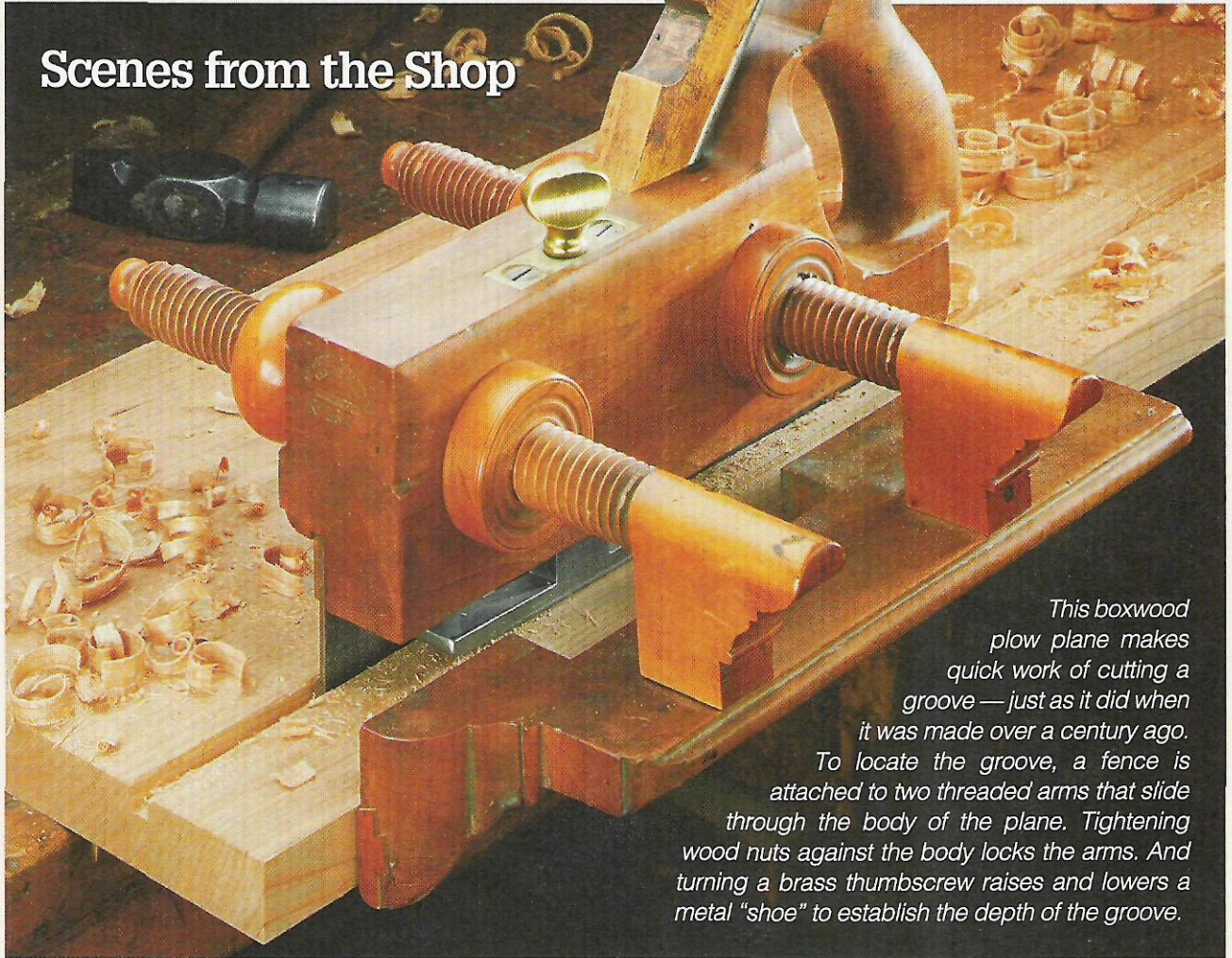

This boxwood plow plane makes quick work of cutting a groove — just as it did when it was made over a century ago.

To locate the groove, a fence is attached to two threaded arms that slide through the body of the plane. Tightening wood nuts against the body locks the arms. And turning a brass thumbscrew raises and lowers a metal “shoe” to establish the depth of the groove.

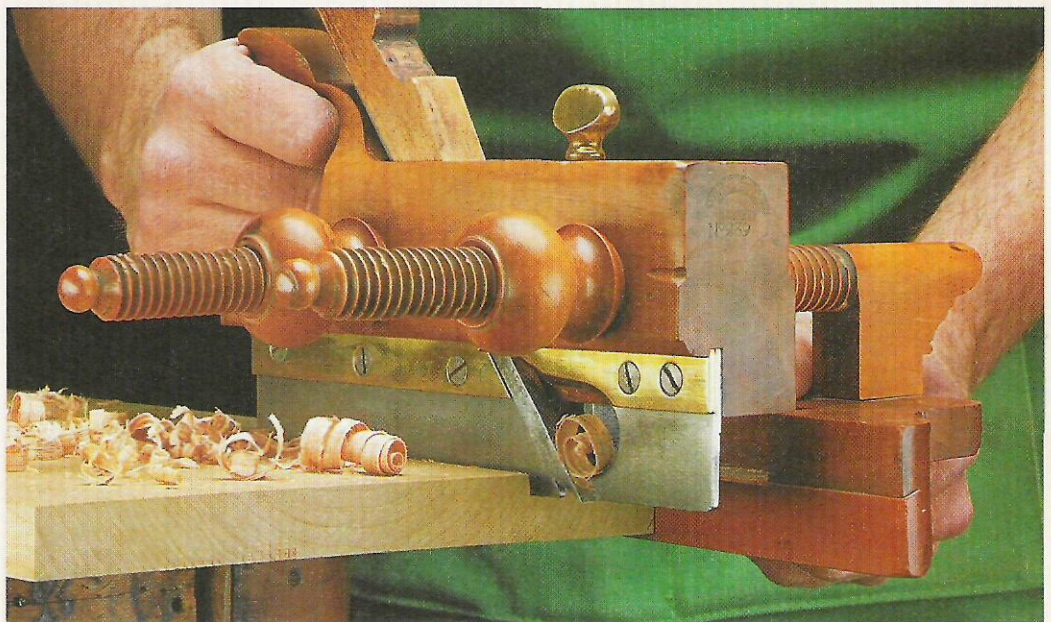

There's no need to worry about any roughness at the bottom of the groove. (It's usually hidden.) So the plane iron is set to make a coarse cut and wedged in place. A long, metal “skate” with a brass back supports the plane iron and provides clearance for thick curls.