

# ShopNotes®

Vol. 8

Issue 48

Tool Review:  
**Jointers**  
*Which one is best  
for you?*



## *Tilt-Out* **Panel Cutting Guide**

*Makes it easy to cut large sheet  
goods quickly and accurately*

- Modular Storage Bins ■ Jointer Extension Tables
- Tuning Up a Jointer ■ Benchttop Jointer Tool Stand



# ShopNotes®

Issue 48 November 1999

**PUBLISHER** Donald B. Peschke  
**EDITOR** Tim Robertson  
**ASSOCIATE EDITOR** Tom Begnal  
**ASSISTANT EDITOR** Bryan Nelson  
**ART DIRECTOR** Cary Christensen  
**SR. GRAPHIC DESIGNER** Kurt Schultz  
**SENIOR ILLUSTRATORS** Roger Reiland  
 Mark Higdon

## CREATIVE RESOURCES

*Creative Director:* Ted Kralick • *Project Developer:* Ken Munkel • *Senior Project Designer:* Kevin Boyle • *Project Coordinator:* Kent Welsh • *Shop Manager:* Steve Curtis • *Shop Craftsman:* Steve Johnson • *Senior Photographer:* Crayola England

## SPECIAL PUBLICATIONS

*Executive Editor:* Douglas L. Hicks • *Art Director:* Steve Lueder • *Sr. Graphic Designers:* Chris Glowacki, Cheryl L. Simpson • *Asst. Editors:* Joe Irwin, Craig Ruegsegger • *Graphic Designer:* Vu Nguyen

## CIRCULATION

*Sub. Serv. Dir.:* Sandy Baum • *New Bus. Dir.:* Glenda Battles • *Circ. Marketing Analyst:* Kris Schlemmer • *Creative Mgr.:* Melinda Haffner • *Renewal Mgr.:* Paige Rogers • *Sr. Graphic Designer:* Mark Hayes • *Billing Mgr.:* Rebecca Cunningham • *Prom. Mgr.:* Rick Jenkins • *New Bus. Mgr.:* Todd L. Bierle • *Asst. Sub. Mgr.:* Joy Krause

## CORPORATE SERVICES

*Controller:* Robin Hutchinson • *Sr. Accountant:* Laura Thomas • *Accounts Payable:* Mary Schultz • *Accounts Receivable:* Margo Petrus • *Prod. Dir.:* George Chmielarz • *Electronic Pub. Dir.:* Douglas M. Lidster • *Network Admin.:* Chris Schwanebeck • *Prod. Assistant:* Susan Rueve • *Pre-Press Image Specialist:* Troy Clark, Minnette Johnson • *New Media Mgr.:* Gordon C. Gaippe • *Multimedia Art Dir.:* Eugene Pedersen • *E-Commerce Analyst:* Carol Schoeppler • *Web Site Editor:* Holly Kilborn • *Web Site Product Specialist:* Adam Best • *H. R. Asst.:* Kirsten Koele • *Admin. Asst.:* Julia Fish, Sherri Ribbey • *Receptionist:* Jeanne Johnson • *Building Maintenance:* Ken Griffith • *Mail Room Clerk:* Lou Webber

## MAIL ORDER

*Operations Dir.:* Bob Baker • *Cust. Serv. Mgr.:* Jennie Enos • *Warehouse Supr.:* Nancy Johnson • *Buyer:* Linda Jones • *Admin. Asst.:* Nancy Downey • *Tech. Rep.:* Matthew TeRonde • *Cust. Serv. Reps.:* Anna Cox, Tammy Truckenbrod, Deborah Rich, April Revell, David Gaumer • *Warehouse:* Sylvia Carey, Dan Spidle, Eric Tullis, Sheryl Knox

## WOODSMITH STORE

*Manager:* Dave Larson • *Assistant Manager:* Paul Schneider • *Sales Staff:* Pat Lowry, Wendell Stone, Jim Barnett, Kathy Smith, Larry Morrison, Harold Cashman • *Office Manager:* Vicki Edwards

ShopNotes® (ISSN 1062-9696) is published bimonthly (Jan., March, May, July, Sept., Nov.) by August Home Publishing, 2200 Grand, Des Moines, IA 50312.

ShopNotes® is a registered trademark of August Home Publishing ©Copyright 1999 by August Home Publishing. All rights reserved.

Subscriptions: Single copy: \$4.99. One year subscription (6 issues), \$21.94. Canada/International add \$10 per year; U.S. funds.

Periodicals Postage Paid at Des Moines, IA and at additional mailing offices.

Postmaster: Send change of address to ShopNotes, P.O. Box 37103, Boone, IA 50037-2103.

Subscription Questions? Write to: ShopNotes Customer Service, P.O. Box 842, Des Moines, IA 50304-9961. Or call 1-800-333-5854, 8:00 am to 5:00 pm, Central Time, weekdays. FAX 515-283-0447

E-Mail: ShopNotes@shopnotes.com  
 Internet: http://www.shopnotes.com

PRINTED IN U.S.A.

Reprinted 2002

# Cutoffs

In this issue, we're taking a close look at jointers. There are two simple projects for a *benchtop* jointer. And we've also included some tips on what to look for if you're considering buying a *stationary* jointer. Finally, there's a tune-up article to make your old jointer work like new.

Speaking of *old* jointers, Cary (our art director) cornered me a while back. He said, "I've got an old jointer at home that needs a tune-up. Could you help me out?"

Well, I guess he caught me in a weak moment, because I agreed. But when Cary dragged the jointer into the shop, I immediately had second thoughts.

The cast-iron table and fence were pitted with rust. All that was left of the power cord was a short stub sticking out of the motor. And the cutter-head only had two of its original three knives, one of which was broken in half.

Still, I *had* agreed to help. So rather than let the jointer get hauled to the dump, we decided to try to restore it.

**MOTOR.** The biggest challenge was the motor. The bearings fit over the shaft like a pair of sloppy shoes. And grease and gunk covered the motor, inside and out. All in all, it looked pretty hopeless.

So why not just buy a new motor?

As I mentioned, this was an *old* jointer. And the housing of the motor actually formed part of the support system for the fence. In a nutshell, if we couldn't get the motor to work, there was no point in going on with the project.

After quite a bit of legwork, we located a repair shop. It looked like it had been around at least as long as the motor. Maybe that's why the guys at the shop were able to track down the bearings without much trouble. In any case, after a thorough check, new wires, and a

paint job, the motor was as good as new.

Once we were sure the motor was functional, the next step was to tackle the cast-iron body, tables, and fence.

**SANDBLASTING.** It was clear that the only way to restore these rusty hunks of metal was to have them sandblasted. That removed the rust alright. But when we got the jointer back, I was surprised and a bit disappointed. Every single part was a dull, battleship gray. And the tables and fence were rough, not smooth and shiny like I'd expected.

**MACHINE SHOP.** So we began to check around for a machine shop to grind the tables and fence flat. That was easier said than done. Let's just say that not every shop is set up (or willing) to work on an antique jointer.

Finally though, we managed to find one. And as it turned out, all that running around was worth it. When we picked up the jointer, the tables and fence were smooth, polished, *and* dead flat.

Of course, the jointer still needed some work. It had to be painted. And we had to round up new knives. (A spare set of knives from a jointer that we tested for this issue fit just right.) Before long, the jointer was up and running.

All in all, I couldn't be more pleased with how the jointer turned out. (Turn to the back cover to see for yourself.)

Having said that, would I do it again? Not right away. But it did make me realize that sometimes we're too quick to discard things just because they happen to be old, or too much trouble or expense.

I know one thing for certain. If I'd followed my first impulse, I'd have missed out on something special — the sound of that jointer humming to life again after sitting silent all those years.

*Perhaps we're too quick to discard something just because it happens to be old.*

*Tim*

# Contents

## Features

### Panel Cutting Guide \_\_\_\_\_ 6

*This wall-mounted panel cutting guide makes it easy to break sheet goods down to manageable size. And a simple fence ensures accurate cuts.*



Panel Cutting Guide page 6

### Tool Review: Jointers \_\_\_\_\_ 12

*Here's an in-depth look at four different types of six-inch jointers. We offer practical suggestions on selecting a jointer that's best suited to the kind of woodworking you do.*

### Modular Storage Bins \_\_\_\_\_ 16

*Organize all your small pieces of hardware with these tilt-out bins. The bins are part of a unique modular storage system that can be customized to suit your needs.*



Modular Storage Bins page 16

### Tuning Up a Jointer \_\_\_\_\_ 20

*Flat, straight, and square stock. That's what you get when you use our simple technique to tune up a jointer.*

### Jointer Extension Tables \_\_\_\_\_ 24

*Jointing a long workpiece is a snap when you add these shop-made extension tables to your benchtop jointer.*

### Benchtop Jointer Stand \_\_\_\_\_ 26

*This sturdy stand turns your benchtop jointer into a stationary tool. Plus it offers a handy way to collect chips.*



Jointer Tune-Up page 20

## Departments

### Readers' Tips \_\_\_\_\_ 4

*Our readers offer their own shop-tested tips dealing with some of the most common woodworking problems.*

### Tool Talk \_\_\_\_\_ 30

*Tips and talk about tools of our trade. In this issue, we look at a unique turning tool and roller guides for a band saw.*

### Sources \_\_\_\_\_ 31

*Information and mail-order sources for the hardware and supplies used to build the projects in this issue.*



Extension Tables page 24

# Readers' Tips



■ There never seems to be a good place to store long, heavy clamps. But this clamp rack solves that problem. By attaching the rack to the back of my bench, I was able to take advantage of the *unused* space underneath, see photo above.

Note: If you don't have access to the back of your bench, you can easily mount the rack to a wall.

**STANDARDS.** The rack I built is anchored to the bench with three hardwood *standards*, see drawing. To make the rack adjustable, I cut a slot in each standard and drilled a series of evenly spaced holes.

## Clamp Rack

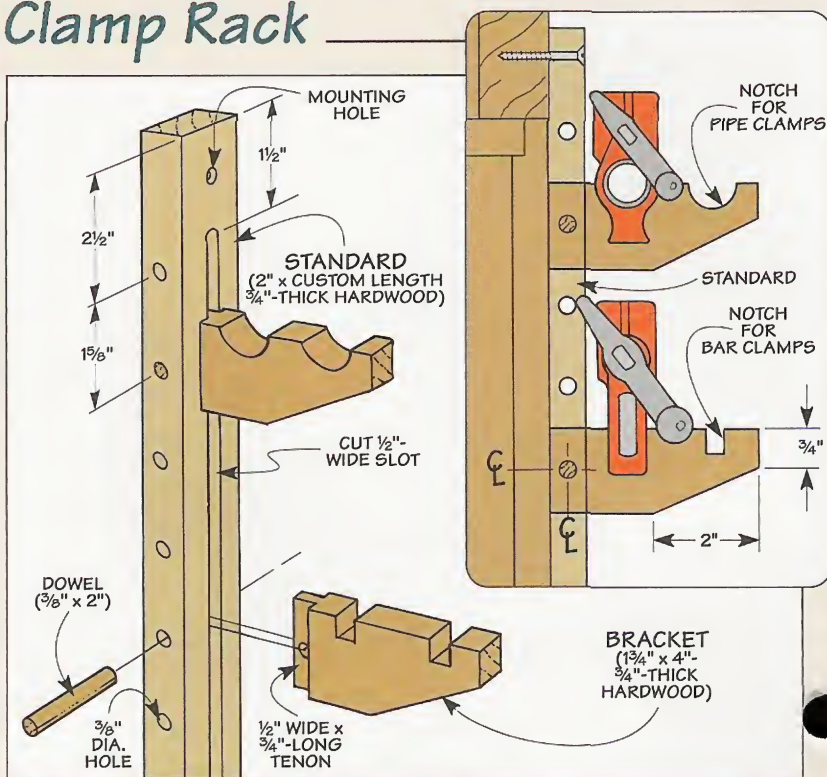

**BRACKETS.** The clamps rest on hardwood *brackets* that fit into the standards. A tenon on each bracket fits into the slot in the standard. And a hole in the tenon accepts a dowel that lets you reposition the bracket.

To keep the clamps from slipping off the rack, I cut notches in each bracket, see detail. These notches

act as "cradles" for the clamps. Note: The size and shape of the notches depends on the type of clamps. Finally, to provide clearance when removing a clamp (or putting it back), I tapered the bottom of the brackets.

*Jim Ryder  
Boise, Idaho*

## Dust Collector Seal

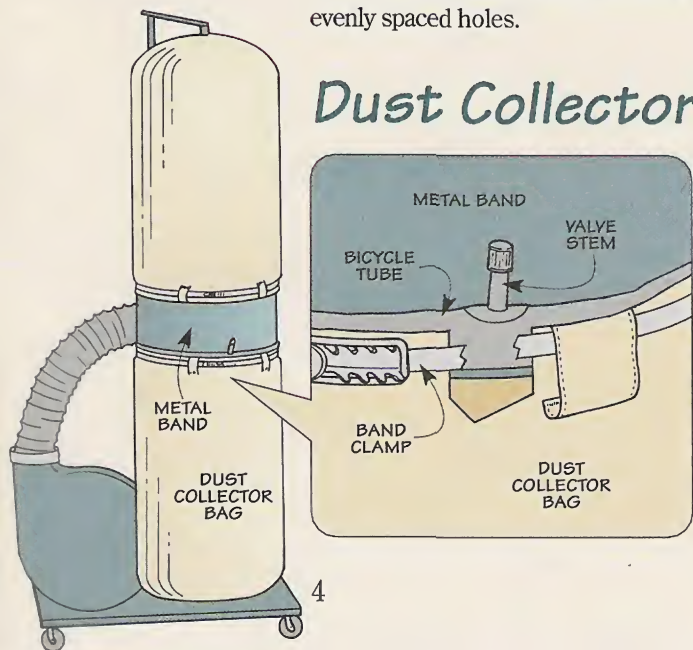

■ I used to turn on my dust collector, only to have a small cloud of dust puff out. The problem was the bag didn't fit tightly all the way around the metal band on the dust collector, see drawing in margin.

The solution was a simple bicycle inner tube, see photo above. (I picked up an inner tube at the local bike shop.) To create a seal that prevents dust from escaping, I stretched the tube around the metal band on



the dust collector. Note: I used an inner tube with a diameter that's slightly smaller than the band and faced the valve stem out.

After fitting the collection bag over the tube, all you need to do is tighten the band clamp on the dust collector, see detail. This seals dust inside the bag where it belongs.

*Rich Dohrman  
Eden Prairie, Minnesota*

# Sandpaper Dispenser

■ This dispenser is a nifty way to hold rolls of sandpaper. Plus it makes it easy to pull out the amount of sandpaper you need and tear off a piece.

Each dispenser consists of a short length of 4" PVC pipe and a cutoff hacksaw blade, see Fig. 1. The sand-

paper feeds out of the dispenser through a slot in the pipe.

The best way I found to cut this slot is to use a 1/4" straight bit in a table-mounted router. To prevent the pipe from rotating during the cut, clamp a scrap to each end, see Fig. 2.

Then make several passes to cut all the way through the pipe.

After securing the hacksaw blade with epoxy, the dispenser is simply screwed to a wall-mounted plate.

*R.B. Himes  
Vienna, Ohio*

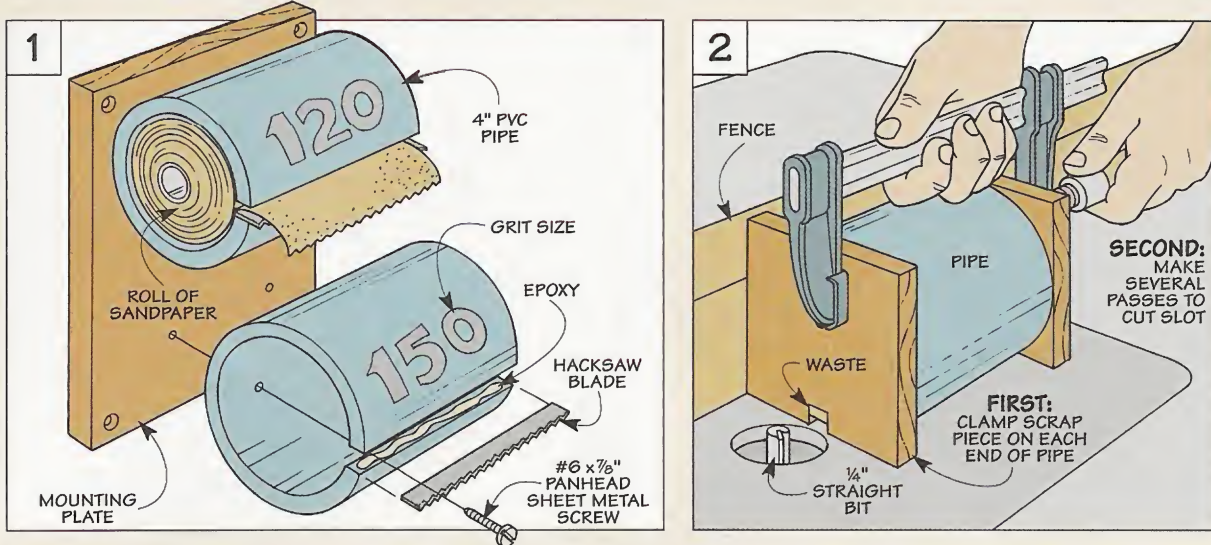

# Scroll Saw Tip

■ Here's a quick way to check if your scroll saw blade is square to the table. Just make a small cutout in a scrap piece of wood, see drawing.

If the cutout slips out *both* sides of the scrap, the blade is square, see detail. But if it wedges on one side or the other, you'll need to square the table to the blade.

*Rick Hutcheson  
Grimes, Iowa*

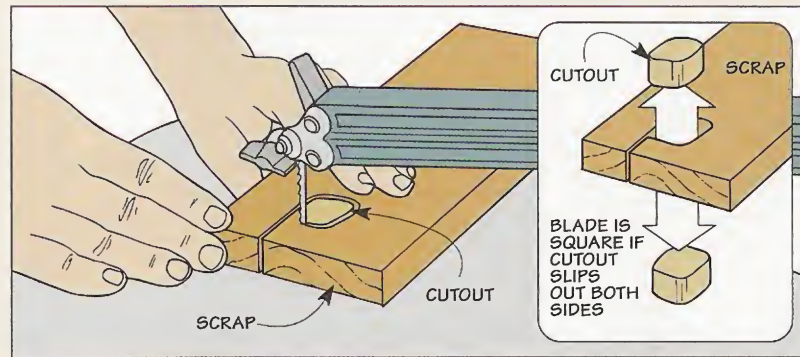

# No-Slip Pull



■ My fingers often slip off my shop-made door pulls. So to improve the grip, I used some self-adhesive, non-slip floor tape, see photo inset. (You'll find it at most hardware stores.)

The tape is applied to each side of the pulls, see left photo. With its rough texture, the tape makes the pulls easy to grab.

*Kent Welsh  
West Des Moines, Iowa*

## Send in Your Shop Tips

If you have a unique shop tip, we'd like to consider featuring it in one or more of our print or electronic publications.

We'll pay up to \$200 for a tip we publish. Just write down the tip and mail it to *ShopNotes*, Attn.: Readers' Tips, 2200 Grand Ave., Des Moines, IA 50312. Or FAX it to 515-282-6741, or send us an e-mail at [shopnotes@shopnotes.com](mailto:shopnotes@shopnotes.com). Please include your name, address and daytime phone number in case we have any questions.



# Tilt-Out Panel Cutting Guide

*It's easy to cut sheet goods down to size with this tilt-out panel cutting guide.*

**L**et's face it. Cutting large sheets of plywood or MDF is never much fun. They're heavy and awkward to handle. Not to mention that wrestling a large sheet of material on the table saw can be downright dangerous.

The obvious solution is to use a circular saw to break them down into pieces of manageable size. There's only one problem. It's often difficult to find enough room to set up a pair of sawhorses and lay the sheet down flat on top of them.

**WALL-MOUNTED GUIDE.** To save floor space, I built a simple panel cutting guide that mounts to the wall, see photo above. The panel cutting guide has a large *grid* that tilts out from the wall and holds the sheet at an angle.

With the workpiece resting against the grid, it eliminates the "long reach" required when cutting sheet goods on sawhorses. Plus, the grid supports the entire surface area of the sheet. As a result, the cutoff portion of the sheet won't sag and cause the saw blade to bind.

**FENCES.** To produce accurate results, the panel cutting guide has two separate fences that are used to guide the circular saw.

If you need to *rip* a sheet of plywood, just slip a long horizontal fence into the rails on the ends of the grid, see photo 'A' at left. To *crosscut* a workpiece, remove the long fence and install a shorter, vertical fence that slides in the rails on the top and bottom of the grid, see photo 'B.'

**SUPPORT BLOCKS.** Whether you're ripping or crosscutting, the plywood rests on a number of small support blocks attached to the grid. A row of blocks at the bottom supports large sheets of material. For smaller pieces, a second row of blocks holds the sheet at a comfortable working height, see photo 'C.'



**A. Ripping.** To get accurate results when ripping, a long, horizontal fence guides the saw.



**B. Crosscutting.** A shorter, vertical fence makes it easy to crosscut sheet goods.



**C. Partial Sheets.** A row of support blocks holds partial sheets at a convenient height.

# The Grid

The foundation of this panel cutting guide is an open grid that serves as a bed for large sheets of material, see drawing at right. To make it easy to pull the grid out from the wall, I wanted it to be lightweight. So I made the grid from 1 by 4 stock (pine). But in order to hold sheet goods flat, the grid also has to be rigid and sturdy.

**DIVIDERS.** To accomplish that, the grid has two long *horizontal dividers* (A) and seven short *vertical dividers* (B) joined together with a series of interlocking notches, see detail 'a.'

Cutting the notches is easy. Start by mounting a  $\frac{3}{4}$ " dado blade in the table saw and then adjust its height to cut halfway through the width of the dividers. Then attach a long fence to the miter gauge to provide support for the dividers, see Fig. 1. To ensure that the notches align, it's best to clamp a stop block to the fence and use it to position the dividers.

After cutting all the notches, the next step is to drill holes in the *lower horizontal divider* (only) for the support blocks that are added later. Then just assemble the dividers and install a single screw where the notches fit together.

**FRAME.** To add rigidity to the grid, it's surrounded with a wood frame. Here again, the *top* and *bottom* (C) and *ends* (D) of the frame

are 1 x 4's. Once these pieces are cut to final length, they're simply screwed to the ends of the dividers.

**SUPPORT BLOCKS.** All that's left is to add the *support blocks* (E) used to hold sheet goods on the grid, see Fig. 2. Altogether, there are sixteen blocks (eight each on the lower hori-

zontal divider and the bottom of the frame). To accept a mounting bolt, you'll need to drill a hole in each support block. But for now, only the blocks on the horizontal divider are bolted to the grid, see Fig. 2a. The blocks on the bottom are installed later along with a lower fence rail.

**NOTE:**  
ALL PARTS EXCEPT SUPPORT BLOCKS ARE MADE FROM  $\frac{3}{4}$ "-THICK SOFTWOOD

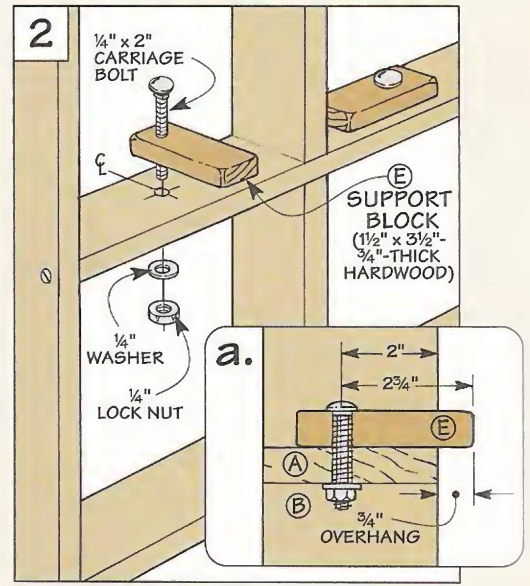
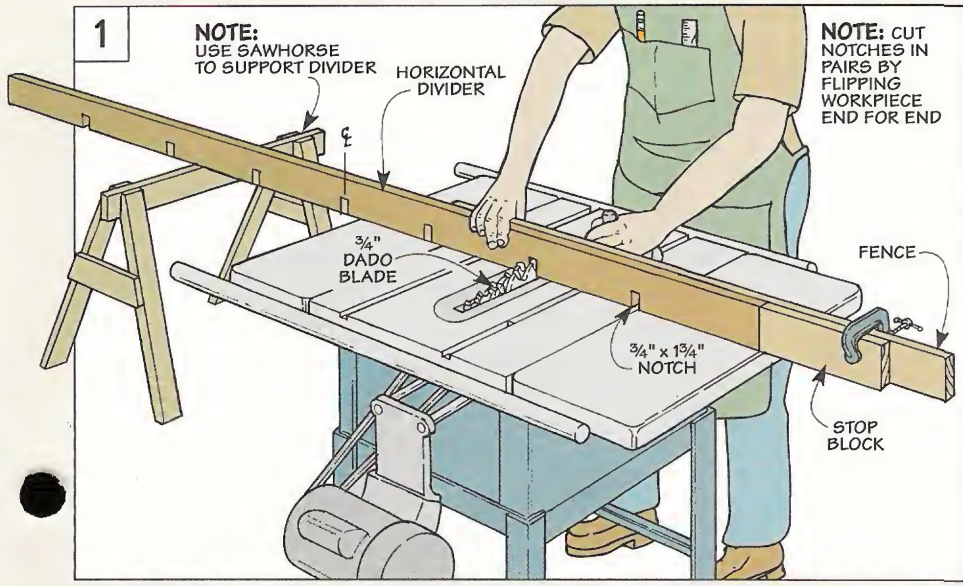
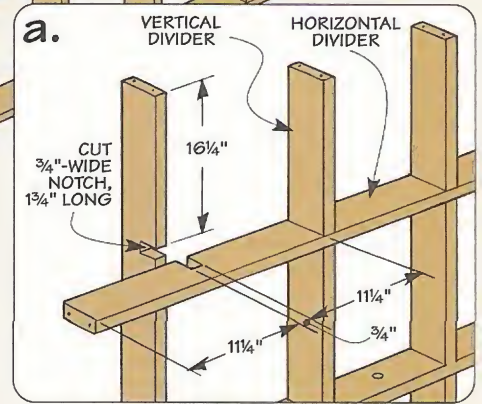
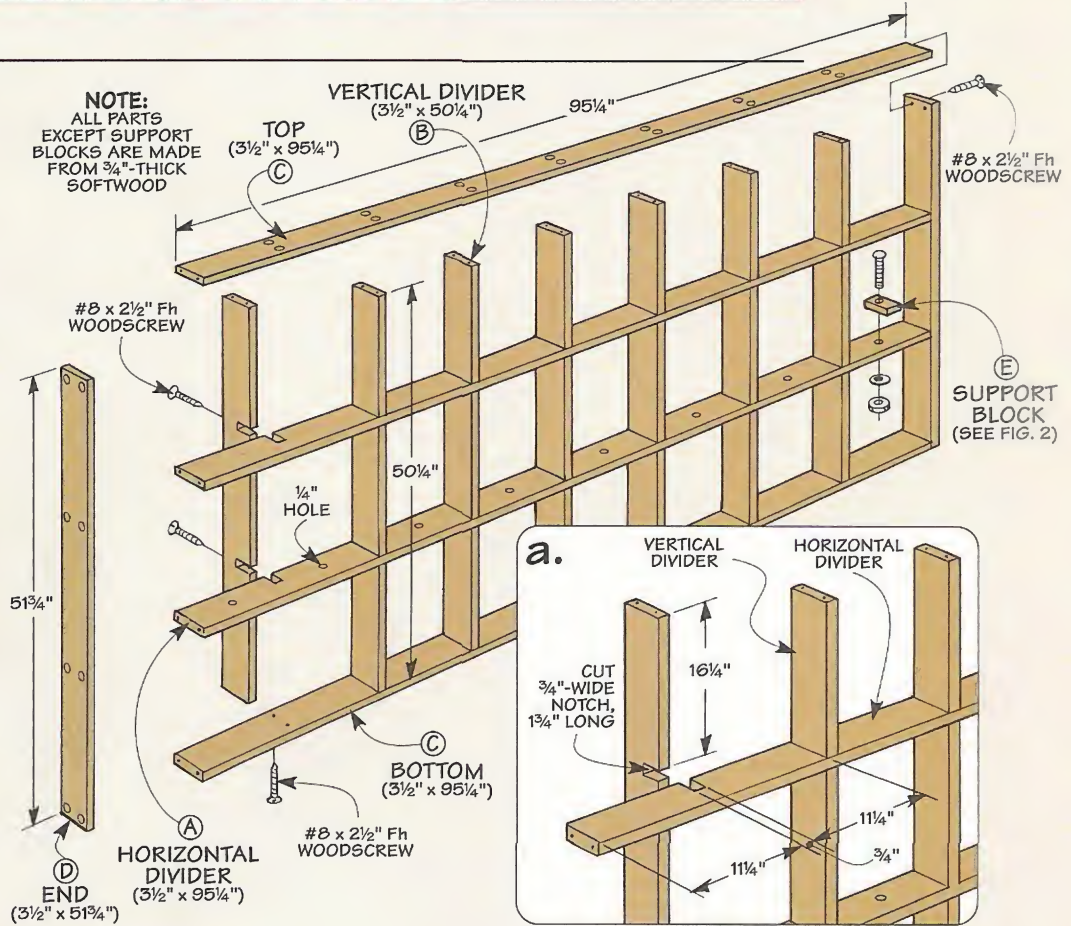

# Fence System

Once the grid is complete, you can turn your attention to the fence system. It consists of two fences that are used to guide the saw and a set of four rails that act as a track for the fences, see drawing.

## Hardware

- (58) #8 x 2 1/2" Fh Woodscrews
- (8) 1/4" x 2" Carriage Bolts
- (16) 1/4" x 2 1/2" Carriage Bolts
- (10) 1/4" x 3 1/2" Carriage Bolts
- (34) 1/4" Washers
- (16) 1/4" Hex Nuts
- (18) 1/4" Lock Nuts
- (4) 5/16" Star Knobs (w/ thru hole)
- (4) 5/16" Fender Washers
- (4) 5/16" x 4" Hex Bolts
- (4) 1/4" x 3/4" Metal Bar (3" Long)
- (4) 3" x 2" Butt Hinges (w/ screws)
- (2) 1 1/2" x 2" Butt Hinges (w/ screws)

## RAILS

The grid is surrounded on all four sides by thick, hardwood rails. Long upper and lower rails (F) are secured to the top and bottom of the grid. And two short side rails (G) are mounted to the ends.

Except for their length, the rails are identical. Each rail is made up of two pieces of 3/4"-thick stock that's ripped to a width of 1 3/4", see Fig. 3.

**T-SLOT.** To create a track for the fences, there's a T-shaped slot that runs the length of each rail. An easy way to form this slot is to start by mounting a dado blade in the table saw and cutting a wide groove in both parts of each rail, see Fig. 3a. Then trim the inside edge of each piece, see Fig. 3b.

**GLUE-UP.** Once the T-slots are completed, you can glue up the rails. The wet glue can make the pieces slip out of alignment when you apply clamping pressure.

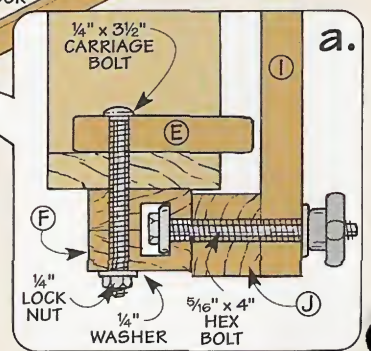
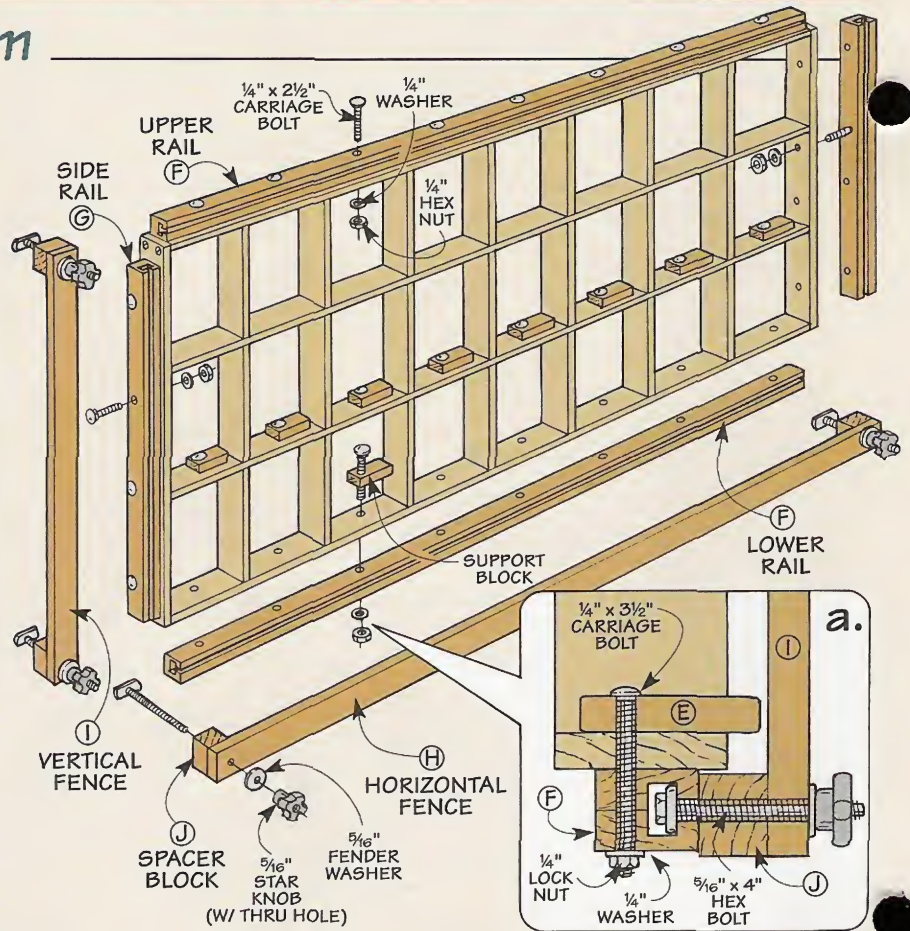

## END VIEW

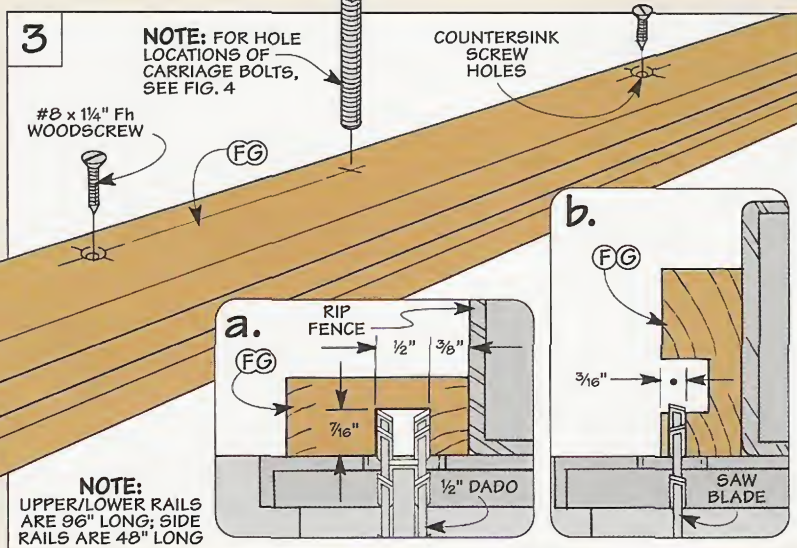
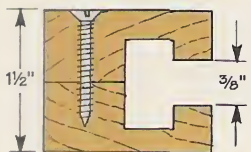

So to ensure that both halves of the T-slots line up, it's best to dry clamp each rail. Then after drilling countersunk shank holes, remove the clamps, apply a thin coat of glue, and install screws to hold the rails together. Note: Locate the screws so they don't interfere with the bolts that are used later to secure the rails.

**MOUNT RAILS.** After cleaning up any glue that squeezes out, you can mount the rails to the grid. Each rail is centered on the length (or width) of the grid. And it's set back 11/16" from the front edge, see Fig. 4a. This creates a lip for a spacer block to ride against as you slide the fences back and forth.

The rails are attached to the grid with carriage bolts. So you'll need to drill holes in the rails and the frame pieces of the grid to accept the bolts, see Fig. 4. One thing to note is the bolts that secure the lower rail are an inch longer than the bolts for the other rails. That's because they also hold the lower support blocks (E) in place, see detail 'a' above.

## FENCES

Once the rails are mounted, you can concentrate on the fences. A long horizontal fence (H) guides the saw when ripping, and a shorter, vertical fence (I) ensures accurate crosscuts, see drawing above.



Here again, the fences are identical except for their length. Each fence is a narrow strip of hardwood, see Fig. 5. To produce accurate results, be sure to use straight-grained stock that's not warped or twisted. It's also a good idea to apply several coats of finish. This will help the fences *stay* straight with changes in humidity.

**SPACER BLOCKS.** The next step is to add a *spacer block (J)* to both ends of each fence. These are thick, hardwood blocks that raise the fence above the grid. When you place a sheet of material on the grid, the blocks provide the necessary clearance *underneath* the fence that allows it to slide back and forth. Note: The spacer blocks provide clearance for sheet goods up to 3/4" thick.

**CLAMP.** The spacer blocks are also part of a simple mechanism that clamps the fence on the rails. What makes this mechanism work is a *pressure plate* that slides inside the T-slot in the rail, see Fig. 5 and the drawing below right.

The pressure plate is a short piece of metal bar stock. (I picked up a strip of bar stock at the hardware store and cut the pressure plate to length with a hacksaw.)

It's a good idea to round the corners of the pressure plate with a grinder (or file). This prevents the

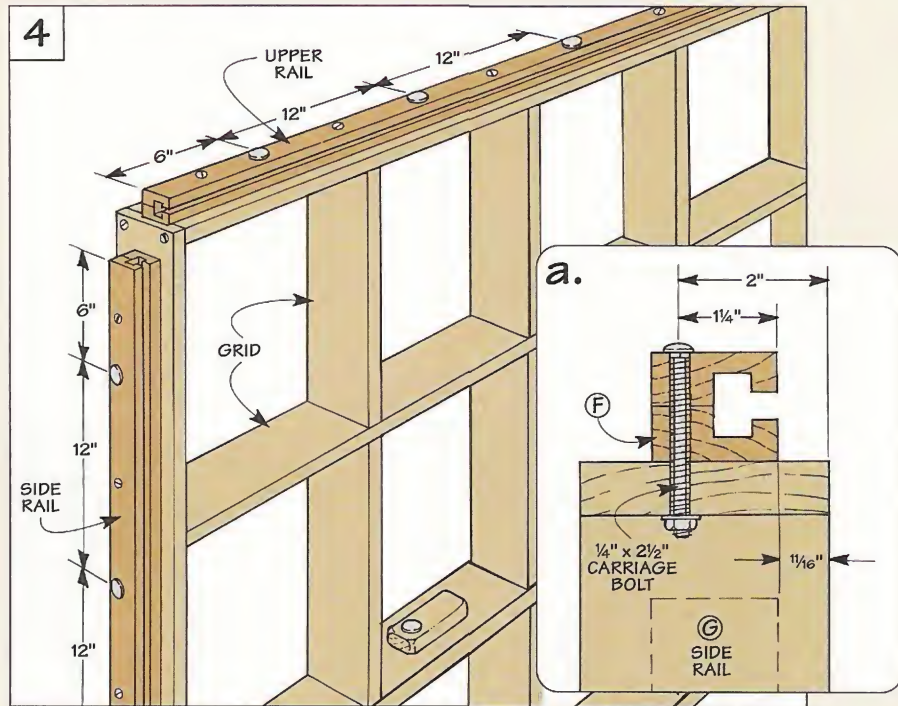

plate from "catching" as you slide the fence along the rails.

To produce the clamping pressure, you'll need to drill and tap a hole in the pressure plate to accept a bolt. The idea here is to thread the bolt all the way into the hole until the head fits tightly against the pressure plate. (This way, it won't spin when you tighten the clamp mechanism.)

Now it's just a matter of inserting the shank of the bolt through holes

drilled in the spacer block and the fence. Threading a knob loosely on the end of each bolt holds the entire fence assembly together. Note: Don't glue the spacer blocks to the fences. They have to move freely to prevent the fences from binding.

**FENCE INSTALLATION.** To install either fence, slip the pressure plates into the rails then tighten the knobs. This pinches the pressure plates against the rails which locks the fence.

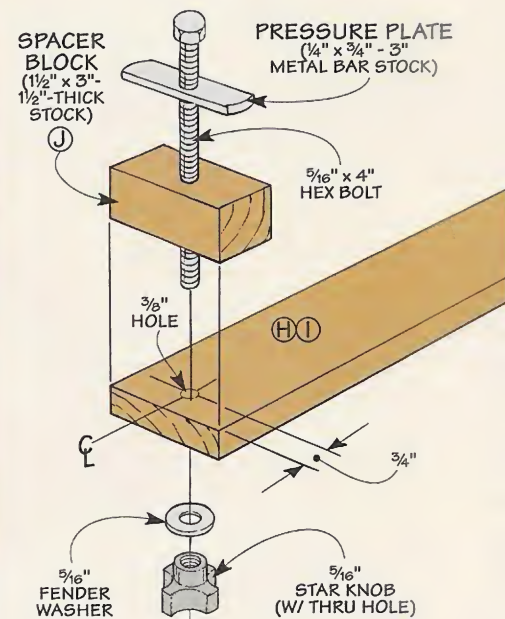
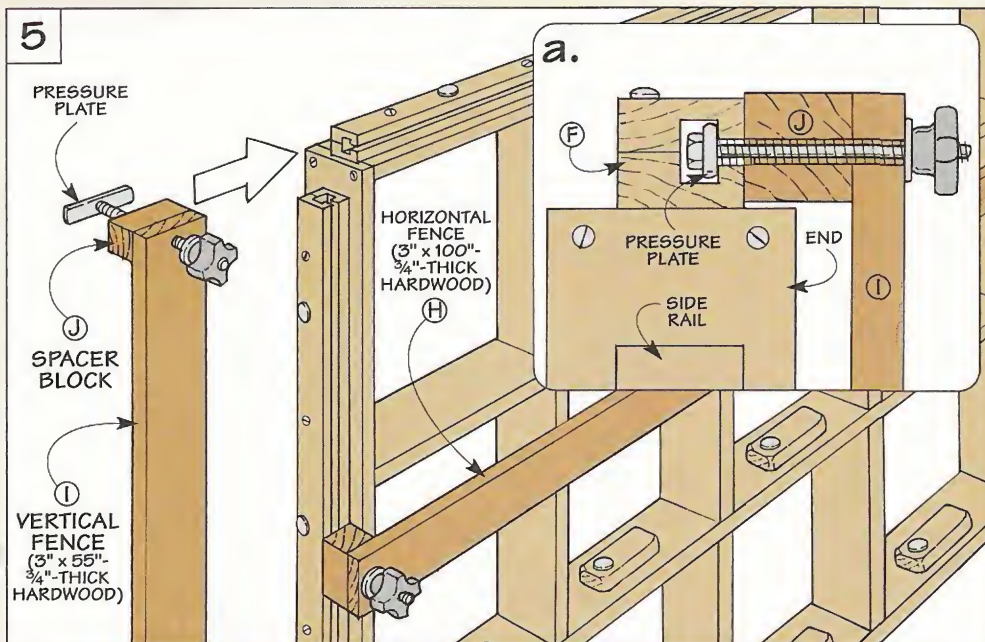

# Mounting the Guide

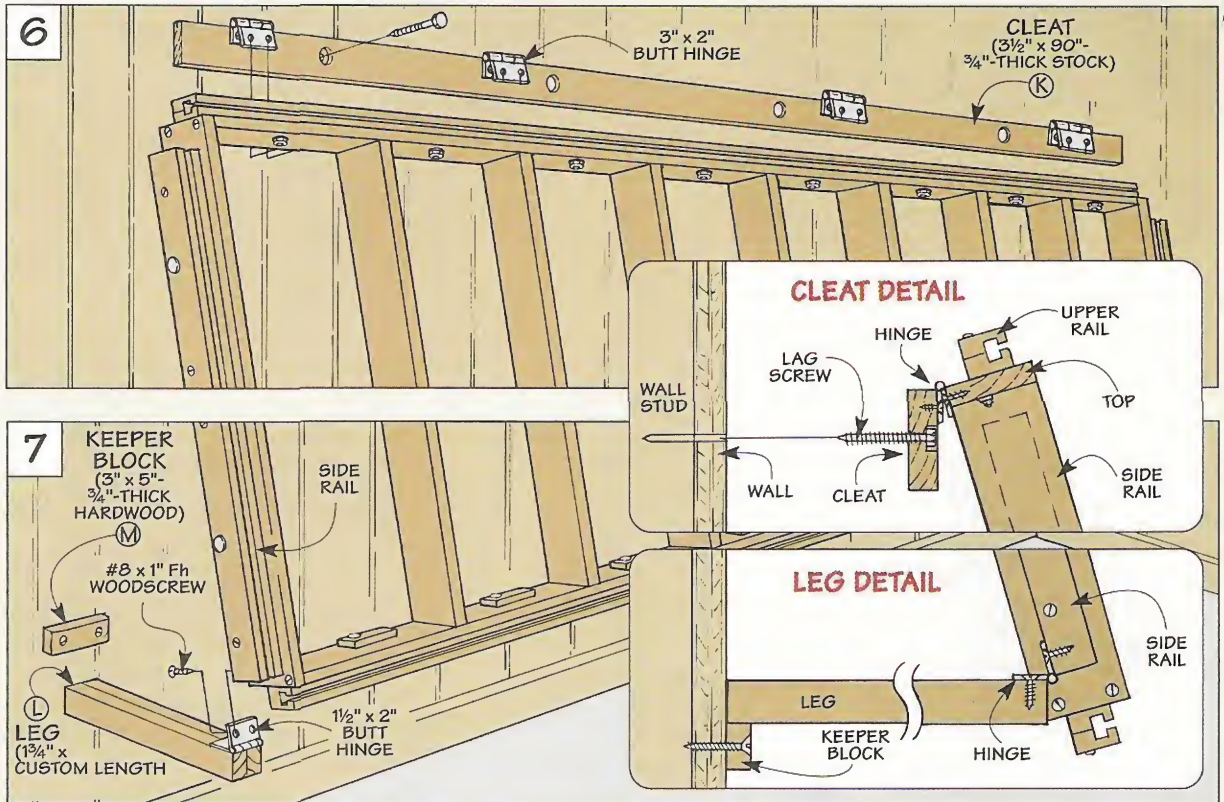

To tilt the panel cutting guide out from the wall (or fold it flat for storage), it's mounted to the wall with hinges. (I used four butt hinges.)

**CLEAT.** One leaf of each hinge is attached to a long *cleat* (*K*) made from 1 x 4 stock, see Figs. 6 and

Cleat Detail above. The other leaf is mounted to the grid.

The cleat needs to be located high enough on the wall so there's about 12" between the bottom rail and the floor. This provides clearance for the saw when starting a crosscut.

and the floor. Since the floor in my shop is a bit uneven, I cut each leg to fit and then hinged it to the side rail, see Fig. 7b.

**KEEPER BLOCKS.** Although the hinges let you swing the legs up against the wall, there's nothing to prevent them from falling down in the middle of a cut. That's the job of the two *keeper blocks* (*M*), see Figs. 7 and Leg Detail above. These are hardwood blocks that are butted against the legs from underneath and screwed to the wall.



▲ **Dual Purpose Legs.** To hold the cutting guide at an angle, prop the legs against the wall. With the legs folded down, they support the weight of the cutting guide, see inset photo.

Before mounting the cleat to the wall, it's a good idea to round up some extra help. (The large size of the cutting guide makes it awkward to handle.) Also, you'll want to make sure the cleat is anchored to the wall. I located the wall studs and secured the cleat with lag screws.

**LEGS.** The next step is to add a pair of *legs* (*L*) to the cutting guide, see Fig. 7. The legs do two things. First, they flip up against the wall to hold the panel cutting guide at an angle, see photo at left. Second, they support the weight of the cutting guide when it's folded flat against the wall, see inset photo.

## BASE

You're almost ready to use the cutting guide. But first, you need to add a base to your circular saw.

The legs are made by gluing up two pieces of 3/4"-thick stock. To support the cutting guide, the legs need to fit snugly between the side rails

In use, the base rides against the fence which ensures a straight, accurate cut. The base consists of two parts: a mounting plate that attaches to the saw and a guide strip that runs against the fence as you make a cut.

**MOUNTING PLATE.** The *mounting plate* (*N*) is cut to the same size as the metal base of your saw, plus the

width of the guide strip. You'll need to cut an opening for the saw blade to stick down through the mounting plate. For safety, be sure the opening is large enough for the blade guard.

**GUIDE STRIP.** Now you can add the *guide strip* (O). It's a narrow piece of hardwood attached to the mounting plate. The guide strip sticks out in front of the mounting plate by a few inches. This helps guide the saw at the *beginning* of a cut.

**ATTACH BASE.** After gluing on the guide strip, you can attach the base to the saw. It's held in place with machine screws and nuts. This requires drilling holes in the metal base of the saw and the mounting plate. Note: The location of these holes will vary depending on your saw.

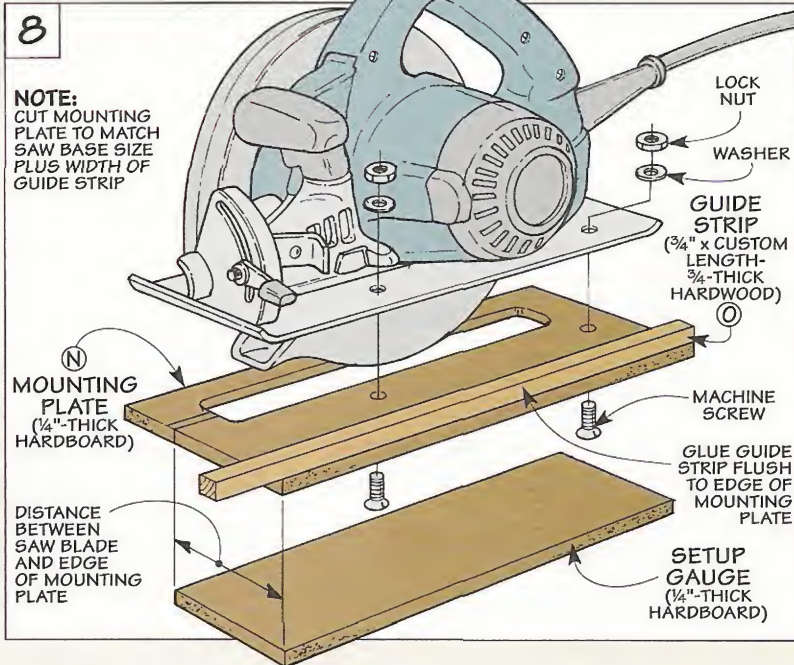

**SETUP**

Now that your circular saw is all ready to go, it only takes a few minutes to set up the panel cutting guide.

**CLAMP LOCATION.** Start by lifting the sheet of material onto the support blocks and clamping it to the grid. If you're planning to rip the sheet, position the clamp *above* the layout line, see drawing 'A' below. This will keep the upper part of the sheet from sliding down and binding against the saw blade.

**POSITION FENCE.** Now slip the fence on the rails and slide it into approximate position. To establish its *exact* location, I use a simple setup gauge, see Fig. 8 and drawing 'B.'

The setup gauge is just a scrap of hardboard that's cut to width to match the distance between the edge of the base and the saw blade. To use the gauge, butt one edge against the fence. Then nudge the fence until the opposite edge aligns with the layout line.

**DEPTH OF CUT.** After locking the fence in place, the next step is to adjust the depth of cut on the saw. I set it to match the thickness of the material *plus* a 1/16". This way, the blade cuts through the workpiece and makes a shallow kerf in the grid.

**RIPPING & CROSSCUTTING.** When ripping sheet goods, slide the base against the fence as you cut from one end to the other, see drawing 'C.' For crosscuts, I found it easiest to start at the bottom and cut toward the top.

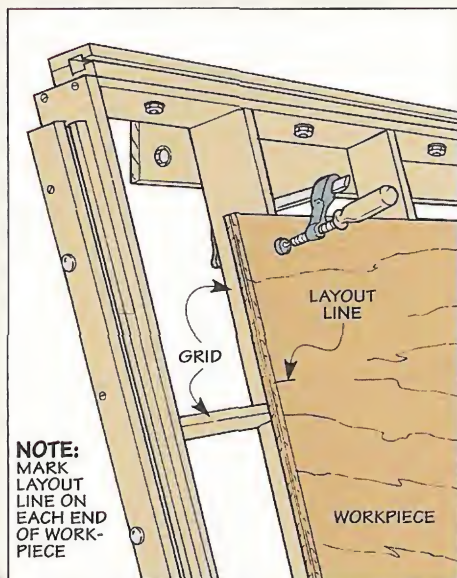

**A. Clamp.** To prevent sheet goods from shifting, clamp them to the grid. Locate clamps above the layout line when ripping.

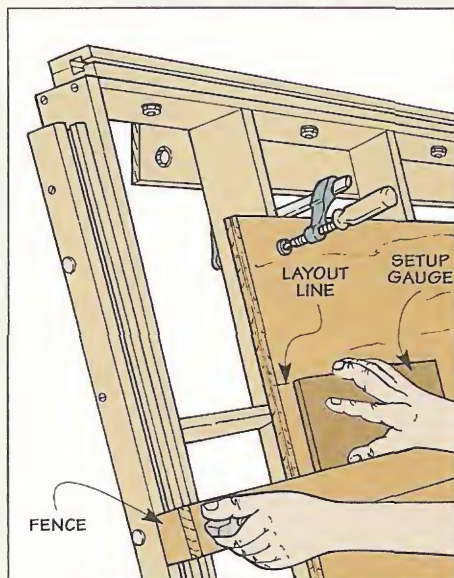

**B. Position Fence.** Use a setup gauge to determine the location of the fence. Then lock the fence securely in place.

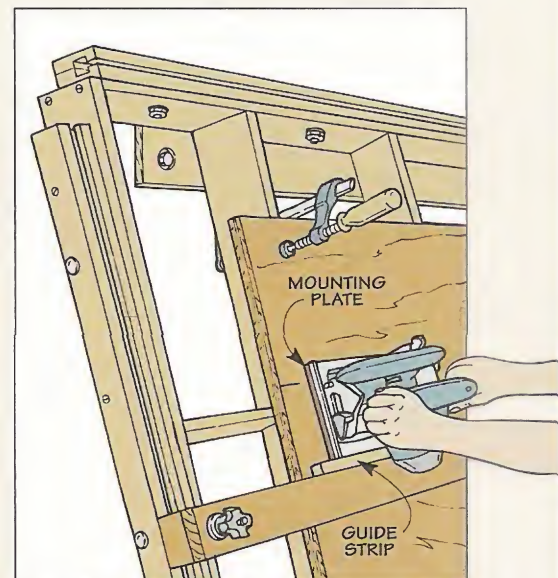

**C. Cut to Size.** With the guide strip riding against the fence, the saw blade should cut precisely on the layout line.

# Tool Review: Jointers



*Four distinctly different types of jointers . . . all with exactly the same cutting capacity. Which one is best for you?*

**I**t's just a hunch. But I've got a feeling there are more six-inch jointers in home workshops than any other size. There's a good reason for this.

They have the capacity to joint the face of a board that's up to 6" wide. That's large enough to handle most of the projects I build. Even so, these mid-size jointers don't take up a lot of space in the shop. Plus, most 6" jointers aren't nearly as expensive as larger models.

There's only one problem. If you're thinking about buying one of these jointers, choosing the right one can be a bit confusing. In fact, I checked around and found over *two dozen* six-inch jointers.

To complicate matters even more, there are at least four different *types* of jointers. As you'd expect, the price of the jointers varies considerably from one type to the next, see chart at right.

So how do you go about sorting all this information out? What type of jointer is best for the kind of woodworking you do? And is it worth spending extra money to buy one type of jointer instead of another?

**A SAMPLING.** To answer these questions, we bought four different jointers that represent a *sampling* of the types that are available, see photo above. Then we put each jointer through its paces — jointing the edge and face of a board, cutting rabbets, and making bevel cuts.

In the process, we began to get a good feel for the most useful features of each type of jointer. And even more

important, it pointed out the limitations (or problems) of one type of jointer — just the kind of information that's nice to know if you're considering buying a jointer.

**BENCHTOP.** The first type of jointer we wanted to try is a portable *benchtop* model. This is a small, lightweight tool that can easily be lifted on or off a bench. (There's more information about benchtop jointers on the next page.) As an example of a benchtop model, we chose the Ryobi jointer that's shown on the bench in the photo above.

**OPEN BASE.** Another type of jointer that's quite common is one with an *open base*. An open-base jointer is quite a bit heavier than a benchtop jointer. It also provides some additional capabilities. (For more about this, refer to page 14.) There are a number of open-base models available. We bought the Delta jointer shown in the background on the left.

**ENCLOSED BASE.** We also purchased an *enclosed-base* jointer. It's a close "cousin" to the open-base jointers, but the model we chose (the Jet in the foreground at right) cost \$50 more. (Turn to page 14 to find out more about enclosed-base jointers.)

**PROFESSIONAL.** Finally, we wanted to try out a jointer that you'd be likely to see in a *professional* cabinetmaker's shop. This type of jointer should offer considerably more capability. But it comes at a price. The General jointer we selected (shown in foreground at left) cost \$799. Note: This type of jointer is featured on page 15.

Jointers at a Glance			
Types of Jointers	Price	Bed Length	Weight
<b>Benchtop</b> Ryobi JP-155	<b>\$319</b>	<b>28"</b>	<b>27 lbs</b>
<b>Open Base</b> Delta 37-190	<b>\$399</b>	<b>46"</b>	<b>210 lbs</b>
<b>Enclosed Base</b> Jet JJ-6CSX	<b>\$449</b>	<b>46"</b>	<b>275 lbs</b>
<b>Professional</b> General 1180	<b>\$799</b>	<b>43"</b>	<b>210 lbs</b>

# Benchtop Jointers

There's no doubt about it. A benchtop jointer is easy to set up. Just pull it out of the box, plug it in, and you're ready to go. (Alright, I *did* have to slip the fence onto the Ryobi jointer that's shown at right.)

**PORTABLE.** One nice thing about a benchtop jointer is you can tuck it under your arm and carry it around. (The Ryobi only weighs 27 pounds.) That's handy if you're working in a small shop. Just store the jointer on a shelf. Then, when it's time to use the jointer, it's no trouble at all to lift it onto the bench or a portable work-surface, see photo 'A' below.

**PLASTIC & ALUMINUM.** It's easy to see why benchtop jointers are so lightweight. The base is often plastic or thin sheet metal. And typically, the fence as well as the infeed and outfeed tables are made of aluminum.

**TABLES.** As with any jointer, the tables on a benchtop model must be flat *and* parallel to each other to ensure accurate results. I'd recom-



mend using a straightedge to check the tables. Even though the jointer you check is only a display model, it should give you an idea about the overall quality of the tables on that particular brand of jointer.

While you're at it, raise and lower the *infeed* table to see if it adjusts smoothly. (The outfeed table on most benchtop jointers doesn't adjust.)

One thing to be aware of is the *length* of the infeed and outfeed tables. Typically, they're quite short — too short to joint a *long* workpiece.

For example, the combined length of the tables (the bed) on the Ryobi is only 28" long. You can buy extension

rollers to create a longer bed, see photo 'B.' (The extensions I bought cost \$45.) Or another solution is to build your own extension tables. (For step-by-step plans, see page 24.)

**FENCE.** Another thing to look at is the fence. Be sure to check out *all* the adjustments. Slide the fence back and forth across the width of the table.

Also, try out the stops that allow you to reset the fence to 45° or 90°. Sometimes they aren't reliable enough to return the fence to the desired setting. In the case of the Ryobi, there are no stops whatsoever, which explains the plastic setup triangle included with this jointer, see photo 'C.'

It's also a good idea to joint the edge of a scrap piece. (This may have to be a "dry run.") Either way, it will make it clear if there's room for your knuckles when making a cut, see photo in margin.

**UNIVERSAL MOTOR.** One final note. You can expect most benchtop jointers to have a *universal* motor (like the motor on a router or circular saw). A universal motor is a mixed blessing.

**VARIABLE SPEED.** On the plus side, it allows you to control the speed of the cutterhead simply by dialing a knob, see photo 'D.'

Take the Ryobi for instance. The speed ranges from 8,000 to 16,000 rpm's. The low end of that range is used to joint plastic. So it's not a speed I'd use much. But at the high end of the range, I was able to joint a piece of bird's-eye maple without tearing out the "eyes." That's impressive.

Unfortunately, there's a tradeoff. At that speed, the Ryobi is a real "screamer." But if you can live with the noise, the glass-smooth surface it produces can't be beat.



▲ The tall, metal adjustment brackets on this fence are a real knuckle-buster when jointing the edge of a workpiece.



A. *Lightweight.* A portable jointer is small and lightweight, so it's easy to set up on a temporary worksurface.



B. *Extension Rollers.* As an option, you can buy extension rollers to provide support for a long workpiece.



C. *Fence.* Since there are no stops on the Ryobi fence, a plastic triangle helps square it up to the table.



D. *Variable Speed.* To "dial in" the desired speed on a benchtop jointer, it's just a matter of turning a knob.

## Open Base

If you have enough space for a stationary tool, you may want to consider a jointer with an *open base*.

**CAST IRON.** The fence and tables on these jointers are usually made of solid, cast iron. As a result, the jointers are quite heavy. (The Delta shown at right weighs 210 pounds.) This extra weight helps dampen vibration.

**MOTOR.** Most open-base jointers run *quieter* as well. That's because they use a belt-driven *induction* motor (like the motor on a contractor-style table saw). As a rule, an induction motor will last longer than a universal motor. These motors run slower (and you can't vary the speed), so expect some mill marks on the workpiece.

▲ The tables on this jointer have a slight "dish." But unless the tables are off by several thousandths of an inch (at least .005"), it's not likely to cause a problem.

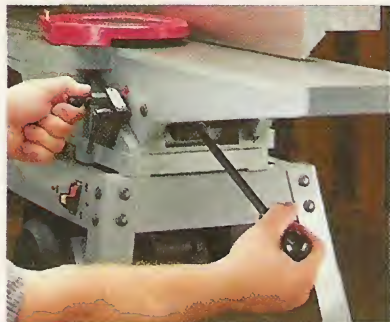

**E. Depth Adjustment.** Changing the depth of cut is quick with a lever, but it's difficult to make fine adjustments.



But you can get around this by slowing down the feed rate.

**RABBETS.** Unlike the benchtop models, most open-base jointers are set up to cut rabbets. To do that, there's a rabbeting *ledge* in the out-feed table that provides clearance for



**F. Fence.** The support on a center-mounted fence sticks out in back, so you can't put the jointer next to a wall.

the uncut part of the board. (You can see this ledge in the photo above.)

**TABLES.** Another advantage to an open-base jointer is that the tables are longer. As a result, they provide more support for a long workpiece.

Be sure to try out the adjustment mechanism for raising and lowering the infeed table. For example, the Delta uses a lever to raise and lower the table, see photo 'E.' It's a quick way to change the depth of cut. But typically, I make extremely fine adjustments. That's harder to do with a lever.

**FENCE.** Finally, take a look at how the fence is mounted. If it's mounted near the *center* of the jointer, the fence supports may stick out in back, see photo 'F.' So you won't be able to locate the jointer right next to a wall.

## Enclosed Base

For a bit more money, you can "upgrade" to a stationary jointer with an *enclosed base*. (The Jet shown in the photo at right cost \$50 more than the Delta.) I like enclosed bases for the simple reason they're easier to clean around.

**DUST HOOK-UP.** Actually, you may not have to spend much time sweeping up chips. Many enclosed-base jointers (like the Jet) have a hook-up that attaches to the hose from a dust collector. Note: The Delta jointer shown above also comes with a dust hook-up that attaches to the chip chute.

Dust collection isn't the only thing that the Delta and Jet have in common. The combined length of the tables

▲ To take care of the inevitable scratches and chips, the Jet jointer comes with a small can of touch-up paint.



(the bed) is identical (46"). And if you removed the base on the Jet, you'd see a belt-driven, induction motor that's the same size (¾ hp) as

the motor on the Delta jointer.

In spite of the similarities, there *are* some subtle differences. For example, the machined surfaces on the Jet are

## SELECTING TOOLS

a bit smoother (and flatter). Granted, it's probably not enough to improve the quality of cut. But it appears as if there's been more attention to details.

**HAND CRANKS.** I also liked the hand cranks used to adjust the tables up and down, see photo 'G.' The cranks let me "tweak" a table up or down precisely and accurately. Plus, they're located right in front of the jointer so they're convenient to reach.

**FENCE.** But the area where I noticed the biggest difference is the fence. The fence on the Jet is easier to adjust. When I move it across the width of the tables, there are two



**G. Hand Crank.** It's easy to make precise depth adjustments with a hand crank on the front of the jointer.



**H. Fence.** Two machined surfaces and a metal "key" allow this fence to slide smoothly back and forth across the tables.

machined surfaces that slide against each other, see photo 'H.' With a metal "key" keeping the surfaces aligned, the fence glides like silk.

**STOPS.** One last thing to consider is the stops on the fence. Ideally, the

stops allow you to tilt the fence and then return it to either 45° or 90°. But I wasn't able to get accurate results with the stops on the Delta or the Jet. Frankly, *both* stop systems seemed like an afterthought.

## Professional

Okay, I know. This *professional*-quality jointer looks suspiciously like an enclosed-base jointer. So what's the difference?

**PRICE.** One of the biggest things is the price. The General jointer we purchased (see photo at right) cost \$799. That's \$350 more than we paid for our enclosed-base jointer. Is it worth the additional money? And just what *can* you expect from a professional-quality jointer?

**PRECISION MACHINING.** For one thing, instead of being *almost* flat, the fence and tables should be *perfectly* flat. And that's exactly what I found on this General jointer — *flat* surfaces that are dead-on accurate.

**FENCE.** In addition to being flat, the fence should be effortless to use. Not only when sliding it back and forth across the table. But also when



tilting it at an angle to cut a bevel.

To accomplish that, the fence on the General is mounted on the *end* of the infeed table, see photo 'I.' This lets you use a single locking lever to control both the side to side movement *and* the angle of the fence.

Basically, the lock lever is a

double-ended socket wrench, see upper margin photo. One end of the wrench fits over an *outside* nut that's part of the locking mechanism. Loosening this nut lets you slide the fence across the table. To tilt the fence, just use the opposite end of the wrench to loosen the *inside* nut.

**STOP SYSTEM.** The fence should also have a stop system that lets you *accurately* return it to the original angle. The General jointer has a simple system that works great, see lower margin photo.

**MOTOR.** There's one final thing to do if you're looking for a professional-quality jointer — open the hood and see what makes it hum. With the General jointer, it's a heavy-duty, 1 hp motor, see photo 'J.' And special motor mounts and a *balanced* pulley help dampen vibration. 🏠



▲ A single lock lever controls the side to side position and the angle of the fence.



▲ Preset Allen screws contact a flip-out aluminum block to create an accurate stop system.



**I. End-Mounted Fence.** Because of its end-mounted fence, you can set this jointer right up against the wall.



**J. Motor.** A powerful motor, special mounts, and a balanced pulley make for a smooth-running jointer.

# Modular Storage Bins

*A modular storage system and these simple tilt-out bins make it easy to organize all your small pieces of hardware.*



**I**t was a ritual I'd been through before. Only this time, I was searching for a lock washer. So I grabbed the dusty Mason jar filled with odd-sized washers and dumped them on the workbench.

As I poked through the pile of washers, it got me thinking about how much time I spend searching for

pieces of hardware that are all mixed together in jars and coffee cans. What I needed was a bunch of plastic trays like the kind you see at home centers. At least that's what I thought.

But after checking around a bit, one thing was clear. I didn't have much choice when it came to selecting the *number* of trays. That

was already determined by the size of the case that held the trays.

**MODULAR STORAGE.** The solution was simple — a *modular* storage system that holds as many bins as I needed, see photo above. The bins do a great job of keeping small pieces of hardware organized. And the modular storage system makes it easy to customize the number of bins.

**BOXES.** The heart of this system is a simple wood box, see Box Assembly on page 17. The box is sized to hold either four small bins or two large bins. Or you can combine different sizes and put two small bins and a large bin in the same box.

If you don't need a lot of storage right now, you may only want to make two or three boxes. But as time goes on, you can always add more boxes to hold additional bins.

Depending on the number of boxes, you can stack them together as in the photo above. (The boxes are held together with a hardboard back.) Or if there are a lot of boxes, you may want to "gang" them together inside a wood frame.

**FRAME.** The frame is designed to fit between the exposed studs in a wall, see photo at far left. So it's an ideal way to take advantage of unused space. If the studs aren't exposed, simply mount the frame to a wall as shown in the photo directly at left.

**TILT-OUT BINS.** Regardless of the number (or arrangement) of the boxes,



**Mounted to Stud Wall**



**Surface Mounted**



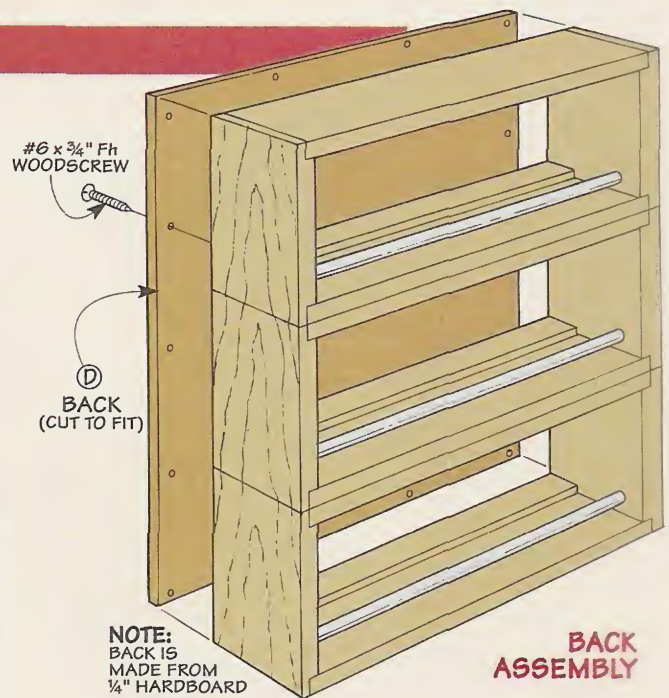
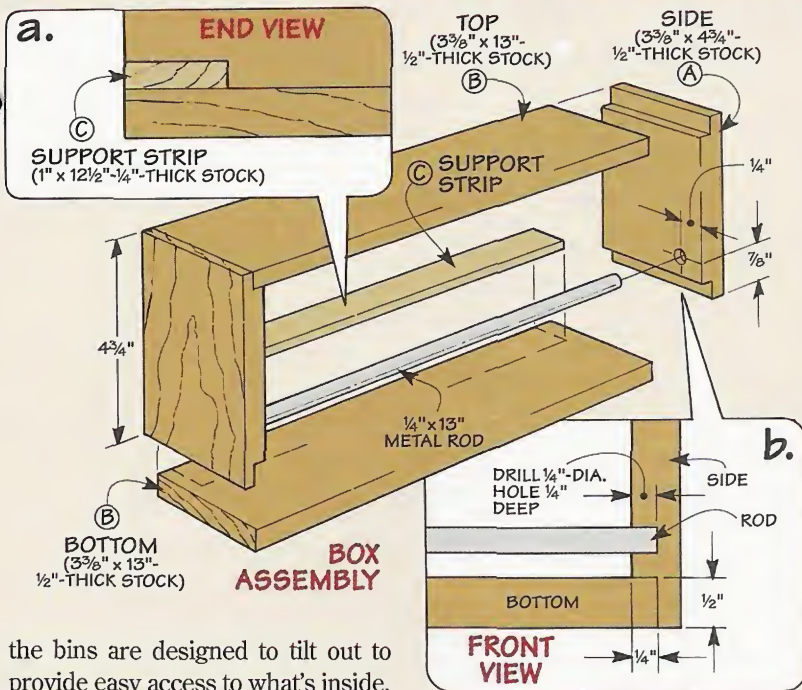

the bins are designed to tilt out to provide easy access to what's inside.

To make this work, the bins hook over a metal rod that spans the front of each box, see drawing 'A' below. (I picked up a length of metal rod at the hardware store.)

The rod acts as a pivot point that lets you tilt the bins out of the box. Even so, there's no need to worry about the bins falling out of the box. That's because the top of the box acts as a convenient "stop," see drawing 'B.'

But there are times when you may want to remove a bin and carry it to wherever you're working. To do that, just tilt the bin out partway and lift it off the rod, see drawing 'C.'

**BUILD THE BOXES.** The first step in building the modular storage bins is to decide on the number of boxes you need. The boxes can be made of most any type of hardwood or softwood. (I used 1/2"-thick pine.)

The two sides (A), and the top and bottom (B) of each box are assembled with simple rabet joints, see detail 'b' in Box Assembly above.

To accept the metal rod, you'll need to drill a stopped hole in each side piece. Using a fence and a stop block to align the side pieces will ensure that the holes align. But the pieces are mirror images, so you'll

have to make two different setups.

**ASSEMBLY.** Once all the holes are drilled, you're ready to assemble the boxes. This is just a matter of fitting the rod into the side pieces then gluing and clamping the box together.

**SUPPORT STRIPS.** Next, to keep the bins level in back (the metal rod raises them slightly in front), I added a support strip (C). It's a thin wood strip glued to the bottom of the box.

**BACK.** Finally, to enclose the back of the box (or boxes), I added a hardboard back (D), see Back Assembly above. After stacking the boxes together, the back is cut to fit then screwed in place. Note: If you're going to build a frame for the boxes, there's no need to attach a back.

## How the Bins Work

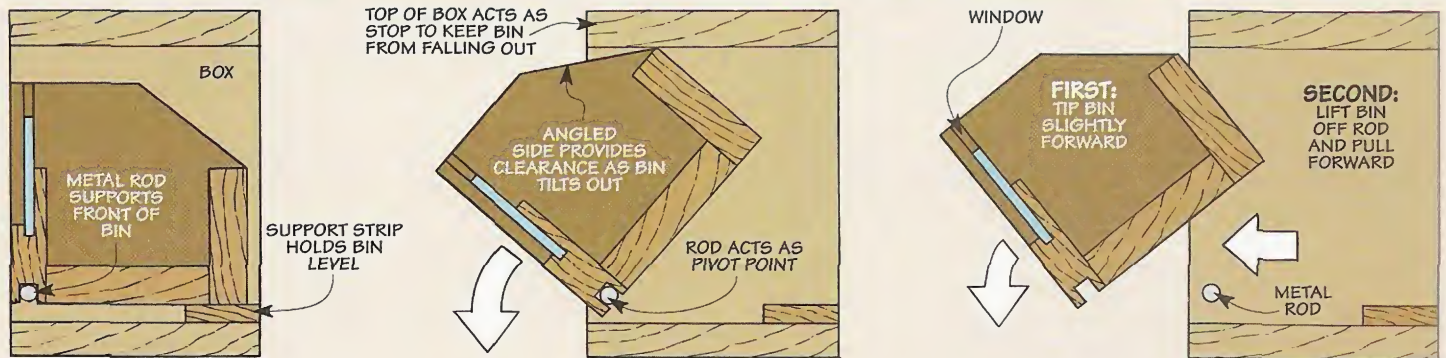

**A. Upright.** Each bin hooks over a metal rod to hold it securely inside the box. A wood strip keeps the bin level.

**B. Tilted Out.** Angled sides and a short back provide clearance as you tilt out the bin. The top of the box acts as a "stop."

**C. Removing a Bin.** All it takes to remove a bin is to tilt it partway out of the box. Then just lift the bin off the metal rod.

# Bins

Once the boxes are completed, you're ready to add the bins. Depending on your storage needs, you can make any number of *small* or *large* bins, see photo at left. And when it's time to put the bins in the boxes, they can be arranged in any combination of sizes, see photo on page 16.

**SIDES.** Regardless of the size of the bins, the *sides* are identical, see drawing at right.

Each side is a piece of 1/4" hardboard with a groove near the front edge that holds a plastic "window." A quick way to make the sides is to rip strips of hardboard to match the width of the sides (3 1/4"). Then after cutting a groove in each strip, crosscut the *sides (E)* to length.

To provide clearance for the bins to tilt forward, the upper back corner of each side is cut at an angle. Here, a simple jig provides a quick way to make the angled cuts, see box below.

**FRONT & BACK.** With the sides completed, I used a similar process to make the *front* and *back* pieces. Only this time, I ripped long strips of 1/2"-thick stock (pine) to width (1 7/8").

To hold the window (and provide

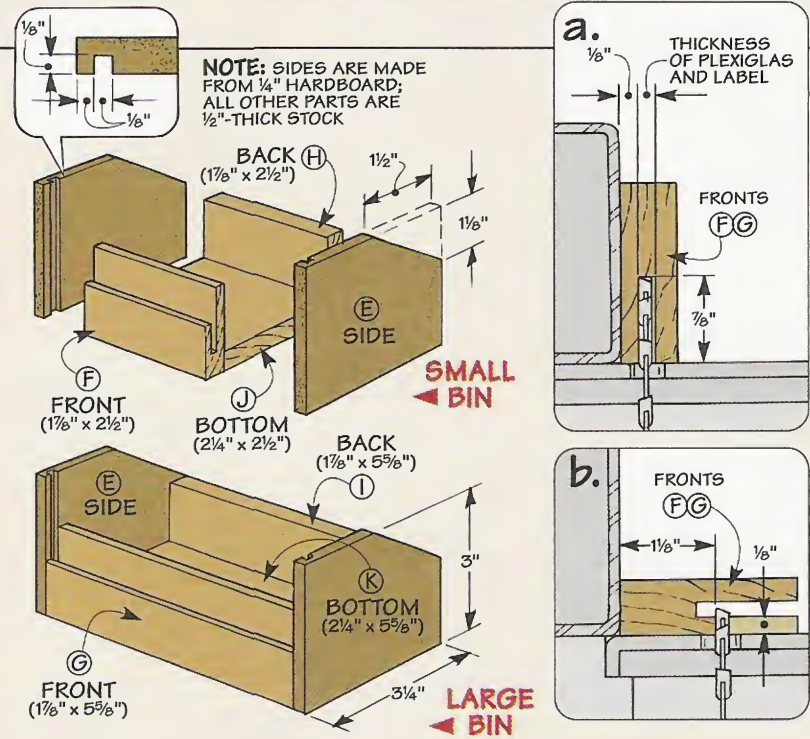

▲ A plastic window and a label that slips behind it let you see at a glance what's inside the bins.

a place to slip in a label), there's a wide, flat "pocket" in each front piece. An easy way to form this pocket is to start by cutting a deep groove in the edge of the strip, see detail 'a' above.

The idea here is to make the groove wide enough so the window and label both fit snugly. To accomplish that, you may have to nudge the rip fence just a bit and make a second pass to widen the groove.

Now it's just a matter of trimming the waste off the front of the strip, see detail 'b.' Note: Be sure to put the *front* of the strip face down on the saw. Then crosscut the *front (F, G)* and *back (H, I)* pieces to final length.

**BOTTOM.** Before assembling the bins, you'll need to rip long strips for the bottom pieces of the bins. Then crosscut each *bottom (J, K)* piece to length and glue the bins together.

# Angle-Cutting Jig

Using a table saw to cut an angle on a small piece (like the sides of the bins) can be tricky. But this angle-cutting jig simplifies things considerably.

The jig consists of two parts: a *base* that carries the pieces through the

saw blade and a right angle *fence* that positions the sides on the jig.

**BASE.** The base is a wide scrap of 1/4" plywood that's ripped to a width of 6", see Fig. 1. This creates a *reference edge* that's used to position the fence.

**FENCE.** The fence is made up of two scrap pieces. To position these pieces, lay out the angle on one of the sides, and align the mark with the reference edge. Then butt the fence pieces against the side and glue them to the base, see Fig. 2.

**TRIM OFF CORNERS.** The sides are mirror images. So stack two sides together (grooves face to face) when trimming the corners at an angle.

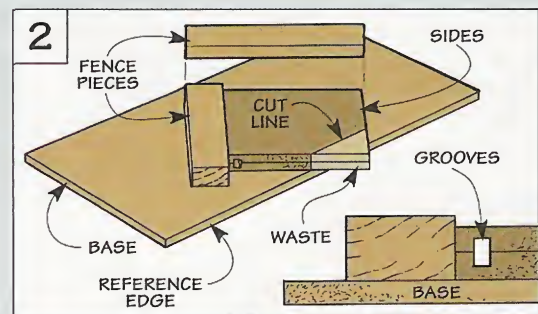
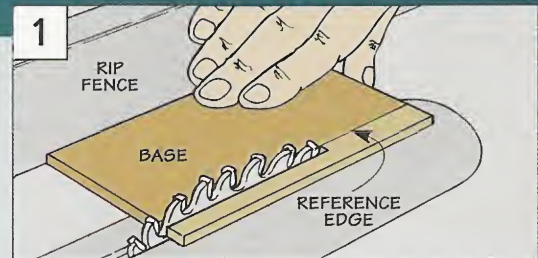

**CUT GROOVE.** At this point, the bins are almost complete. But in order to hook them onto the metal rods in the boxes, you'll need to cut a groove in the front piece of each bin, see Figs. 1 and 1a. A straight bit in a table-mounted router makes quick work of this. Note: To provide extra support for the small bins, I used a squared-up push block.

**WINDOWS.** Now all that's left is to add a plastic window to each bin, see Fig. 2. (I made the windows from 1/8" Plexiglas.) A semi-circular notch in each window acts as a finger pull that makes it easy to tilt out the bins.

When cutting these notches, a jig clamped to the drill press table makes it easy to position each window. To avoid chipout, I used a spade bit and set the drill press to run at its *slowest* speed. (In my case, that was 350 rpm's). Note: Applying a strip of cellophane tape to the window further reduces chipout.

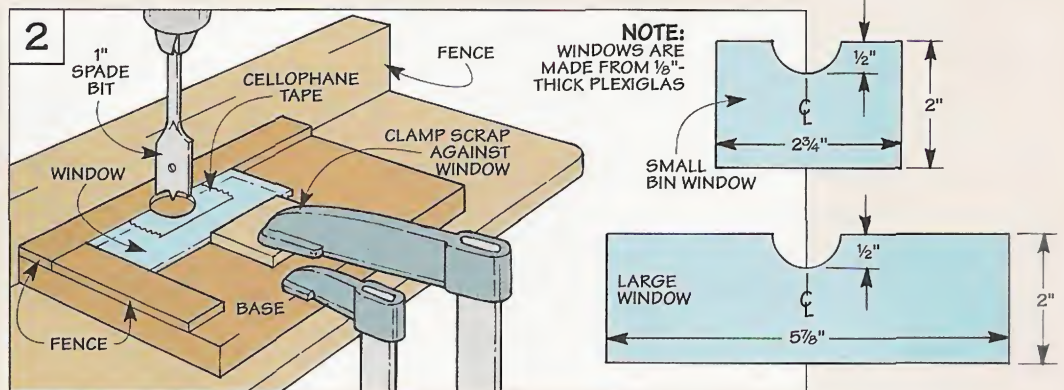
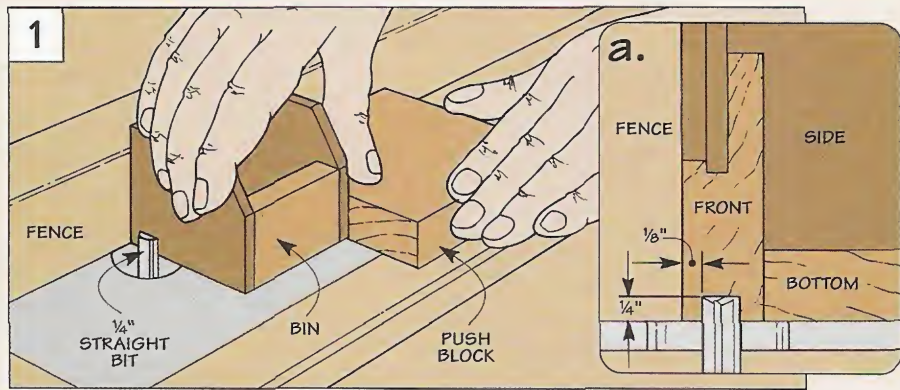

## Frame

If you build a lot of boxes, a simple wood frame provides a handy way to hold them all together, see drawing.

**RAILS & STILES.** The frame consists of a pair of *stiles* (L) connected by two *rails* (M). To fit the frame between the exposed studs on a wall (see photo on page 16), the rails are 14 1/2" long. But the length of the stiles will vary depending on the number of boxes. To determine their length, stack the boxes together, measure the overall height, and add the combined width of the rails (4").

**CUT NOTCHES.** After cutting the stiles to length, you'll need to notch each end to accept the rails, see detail 'a.' Then simply glue and screw the frame together.

**INSTALL BOXES.** Once the frame is complete, it's just a matter of installing the boxes. I started with the lower box. After placing it on the bottom rail, the lower box is just screwed to the stiles. Then, one at a time, stack each remaining box and secure it with screws.

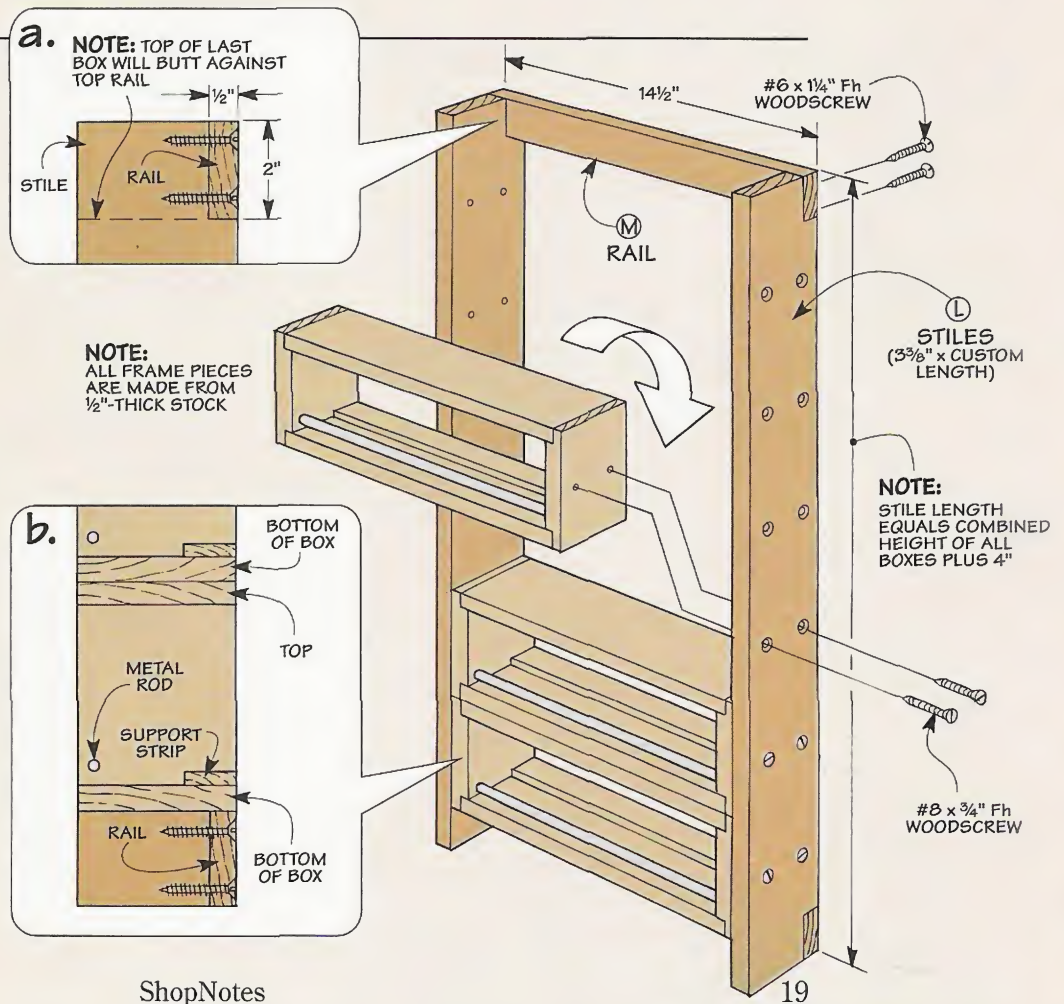

# Tuning up a Jointer

*Keeping your jointer tuned up pays off in stock that's flat, straight, and square.*

A jointer has two main jobs: to flatten the face of a board, and to straighten and square up the edge. Sure, you can use it to cut a bevel or rabbet. But the real “meat and potatoes” work of a jointer is getting stock *flat, straight, and square*.

That sounds pretty easy. After all, with the long, flat tables and fence on a jointer, it seems like it would be hard to go wrong.

Maybe that's why it's so frustrating when the wood fibers in the edge of a workpiece tear out. Perhaps there's a scoop (snipe) in the end of the board. Or when you sight down the edge, it's dished out (or there's a hump) in the middle.

**TUNE-UP.** Fortunately, all it takes to solve these problems is a simple tune-up. This won't require any special tools



## JOINTER ANATOMY

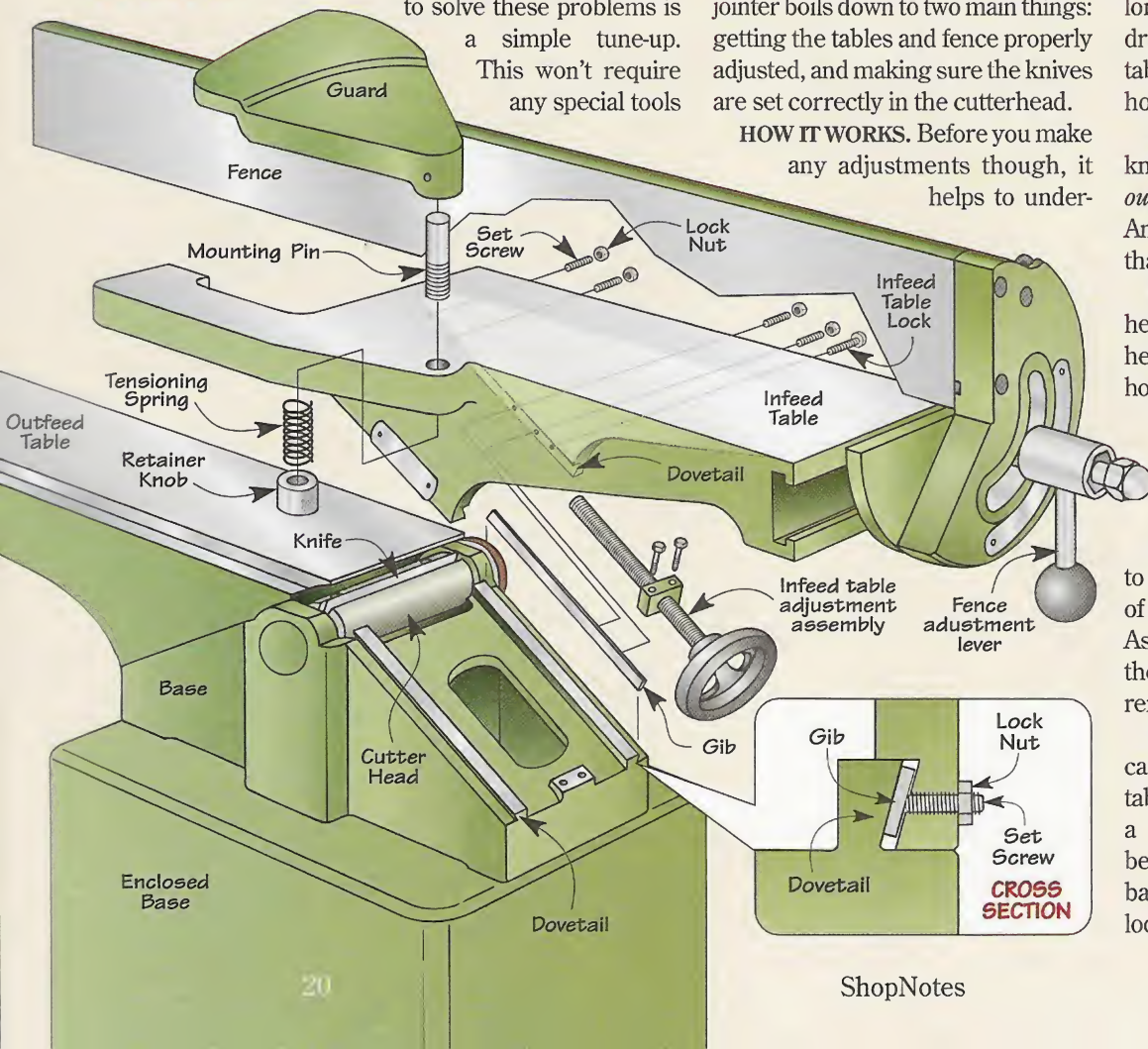

or materials. Yet it will make a big improvement in the quality of the cut.

The procedure for tuning up a jointer boils down to two main things: getting the tables and fence properly adjusted, and making sure the knives are set correctly in the cutterhead.

**HOW IT WORKS.** Before you make any adjustments though, it helps to under-

stand how all the parts of a jointer work together.

The workpiece is supported by a long *infeed* and *outfeed* table, see drawing at left. In between these two tables is a rotating *cutterhead* that holds the *knives*.

If the jointer is set up properly, the knives are at the exact height as the *outfeed* table (at the top of their arc). And the *infeed* table is adjusted *lower* than the knives (usually  $\frac{1}{32}$ " to  $\frac{1}{16}$ ").

It's *this* difference (between the height of the infeed table and the height of the knives) that determines how much material is removed. As you make a cut, the knives slice a thin layer of material off the workpiece which rides smoothly onto the outfeed table.

**DOVETAILS.** Each table is secured to the base of the jointer by two pairs of interlocking *dovetails*, see detail. As you adjust the tables up or down, the dovetails ensure that they remain parallel to each other.

**GIB.** But over time, the dovetails can wear slightly which allows the tables to sag. To compensate for this, a flat, metal bar called a *gib* fits between the dovetails (usually in back of the jointer). Tightening (or loosening) the gib realigns the tables.

## Parallel Tables

It almost goes without saying. To produce a *straight* edge, the tables on a jointer need to be *flat*. But there's more to it than that.

**PARALLEL.** The infeed table and the outfeed table must also be *parallel* to each other. If the tables slope toward the cutterhead, you end up with a hump in the jointed edge, see drawing and detail 'a' at right. If the tables sag at the ends, the edge will be slightly scooped, see detail 'b.'

Now the tables may not be "off" by all that much. But even the thickness of a couple sheets of paper is enough to cause problems.

**ADJUST TABLES.** To adjust the tables so they're parallel, start by raising the infeed table up to the level of the outfeed table. Then lay a long, metal straightedge across both tables, see Fig. 1.

The goal here is to get both tables to contact the straightedge *uniformly* along its entire length. That's where the gibs come in, see drawing on opposite page. By adjusting the amount of pressure against the gibs,

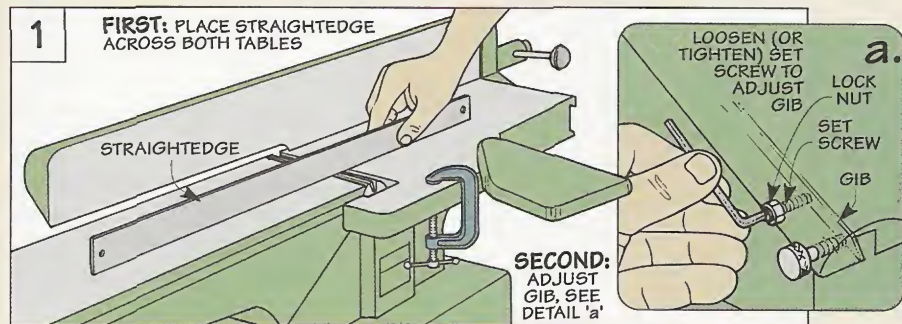
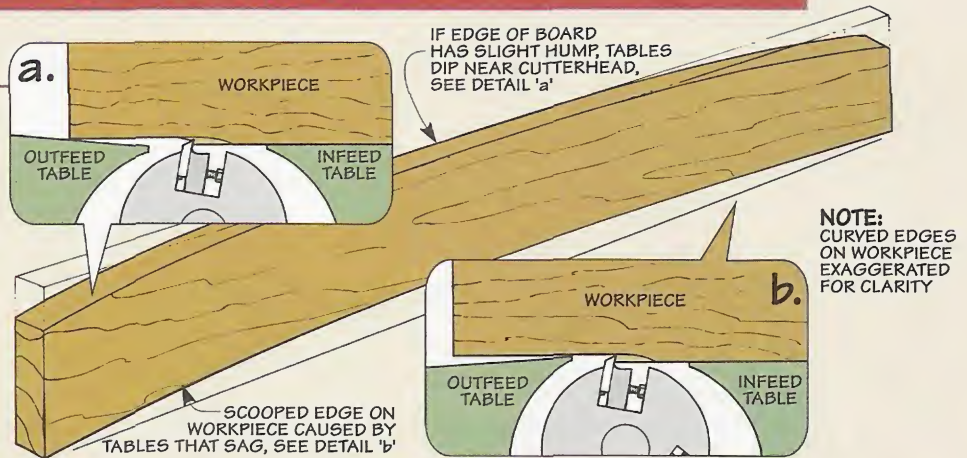

you can raise or lower the appropriate end of each table.

To do this, loosen the lock nuts on the set screws that hold the gib in place, see Fig. 1a. Then tighten (or

loosen) the set screws to raise (or lower) the end of the table. When the tables contact the straightedge *evenly* along its entire length, simply retighten the lock nuts.

## Adjusting Outfeed Table

Another aggravating problem is when you get a heavy cut (snipe) at the end of a board, see drawing.

If the outfeed table is too high, the workpiece catches on the front edge of the table, see detail 'a.' This causes snipe on the *front* of the board. If the table is too low, the snipe occurs at the *back* end, see detail 'b.'

**ADJUST TABLE HEIGHT.** To prevent either of these things from happening, you'll want to set the outfeed table at the *exact* same height as the knives. Start by placing a straightedge on the table so it extends over the knife, see Figs. 2 and 2a. Then raise (or lower) the table until the knife barely touches the straightedge.

To check the adjustment, rotate the pulley (or belt) and listen for a "tick." This indicates the knife is just touching the straightedge.

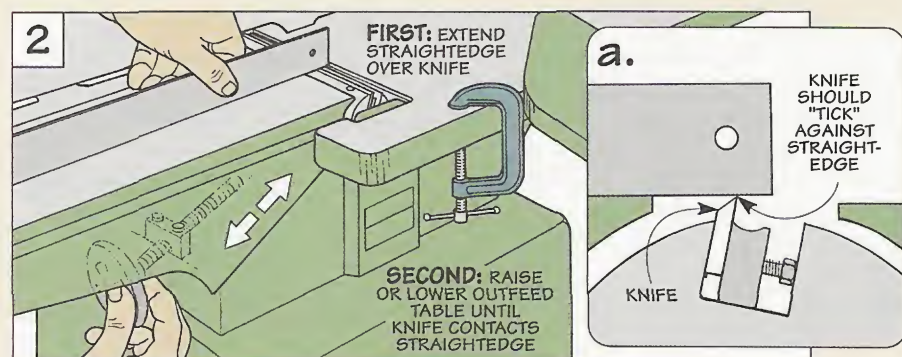
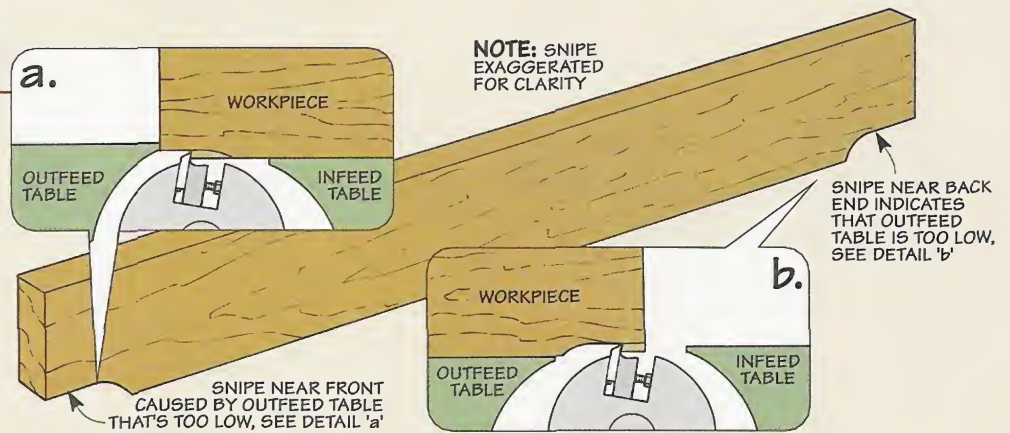

# Setting Knives

Adjusting the tables on a jointer to produce a smooth, square cut is only half the story. The other half is making sure the knives in the cutterhead are sharp and properly adjusted.

**HONE KNIVES.** If the knives are dull (or there's a small nick), you can restore the edges with a sharpening stone. To hold the stone at a consistent angle, I use a simple guide, see box below. But if the knives have a large nick, a honing guide isn't the best solution. (You'll have to remove too much material.)

**SHIFT KNIVES.** A better solution is to shift one of the knives in the cutterhead to the side. This offsets the nick by a small amount which results in a smooth cut.

## CHANGING KNIVES

Eventually, the knives will get too dull (or nicked), and you'll need to replace them with a set of sharpened knives. (I have a spare set of knives.)

**Safety Note:** Be sure to unplug the jointer before changing the knives. Also, to provide room to work, remove the fence and guard (or clamp the guard out of the way).

**REMOVE KNIVES.** The first step is to remove the dull knives. Actually, to make it easy to keep track of things,

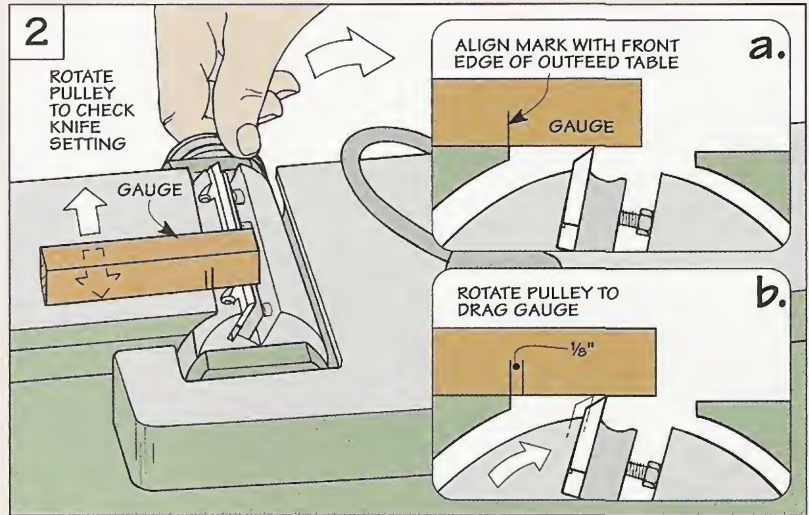
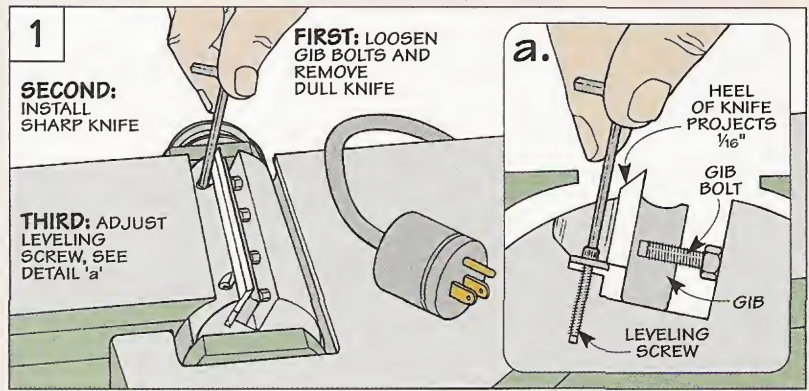

I only work on *one* knife at a time.

On most jointers, the knife is held in place by a metal bar (gib) and a bolt, see Fig. 1a. To remove the knife, loosen the bolts. Then care-

fully lift out the knife and the gib.

Usually, you'll find gunk on the knife, gib, and in the slot in the cutterhead. So I clean these with mineral spirits. Note: Be careful when you clean the knife. Even a dull cutting edge can give you a wicked cut.

**INSTALL KNIFE.** Now you're ready to install the sharp knife. Start by putting the gib back into the slot in the cutterhead. Then slip the knife between the gib and the side of the slot. Note: The bevel on the knife should face the outfeed table.

With the knife in place, tighten the gib bolts until it's snug (not tight). To prevent the knife from twisting, it's best to start with the center bolts and work toward the ends.

**ADJUST HEIGHT.** The next step is to adjust the height of the knife. To support the workpiece as it slides onto the outfeed table, the knife has to be perfectly level with the table.

I start by *roughly* positioning the knife. The goal is to have the "heel"

## Honing Guide

A honing guide makes it easy to "touch up" a dull edge on your jointer knives. This honing guide has *two* sharpening stones that are sandwiched between wood blocks, see photo below and Sources on page 31.

**STONES.** If the knives only need a bit of work, I use the 400-grit stone. But for *small* nicks, the 180-grit stone is best. Just be sure to follow up with the finer grit. Either way, apply a few drops of oil to the stone as a lubricant.

**USE.** To use the honing guide, set it on the knife so the stone rests against the bevel, see detail.

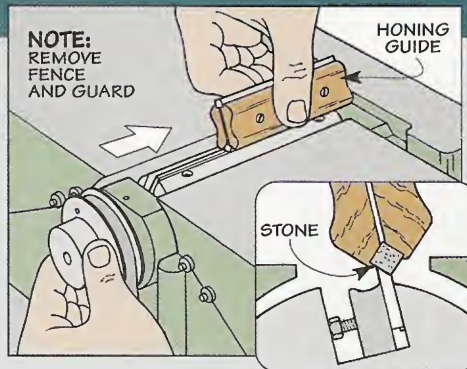

Now hold the pulley (to keep the cutterhead from rocking) and make a smooth, firm stroke across the knife. It's important to remove the same amount of material from each knife. So count each stroke and make the same number of passes on each knife.



of the knife project about  $\frac{1}{16}$ " above the cutterhead, see Fig. 1a.

**LEVELING SCREWS.** To accomplish this, you may have to raise or lower the knife. This is just a matter of turning a pair of leveling screws to push the knife up, see Figs. 1 and 1a. Or, to lower the knife, turn the screws the opposite way and tap the knife down with a wood block.

All it takes is a slight turn to adjust the leveling screws — maybe just an eighth of a turn. The important thing is that the knife projects the *same* amount at each end.

**GAUGE.** To check the adjustment, I use a simple gauge. It's just a scrap that's laid on the outfeed table so it rests on the knife, see Fig. 2a. (Be sure the scrap has a *straight* edge.)

To use the gauge, make a pencil mark on the scrap that aligns with the front edge of the outfeed table. Now rotate the pulley (or belt) so the edge of the knife "catches" the scrap and drags it forward, see Fig. 2b.

The actual distance it travels isn't critical. (I adjust the outfeed table as needed so the scrap moves about  $\frac{1}{8}$ ".) Now make a *second* mark on the scrap that aligns with the outfeed table, see Fig. 2b. This creates a reference that's used to check the opposite end of the knife.

To check the adjustment on this

end, align the first mark with the outfeed table and rotate the pulley again. Ideally, the knife will drag the scrap the same distance. If the second mark aligns with the outfeed table, it means that both ends of the knife are set at the same height.

At this point, it's just a matter of tightening the bolts *securely*. There's only one problem. As soon as you tighten them, the knife creeps up. The trick is to *anticipate* this movement. This is a trial and error process. But after a few tries, you'll get a feel for how much the knives will move.

To adjust the remaining knives, simply repeat the process. Then adjust the outfeed table so it's level with the newly installed knives, refer to page 21.

**TIME.** So just how long does all this actually take? Well, on a good day, I can change the knives in an hour. But to be honest, it may take longer. I've spent as long as four hours setting the knives. (For information about a knife-setting jig that speeds up the process, see box below.)

### FENCE, GUARD, & BELT

Once the knives are set, there are just a few more things to check.

**SQUARE FENCE.** First of all, after you reinstall the fence, don't forget

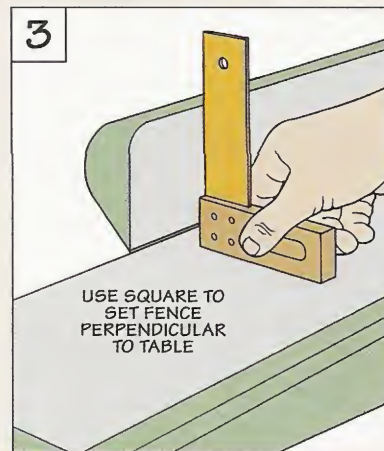

to square it up to the table, see Fig. 3. Otherwise, you'll end up with a beveled edge instead of one that's square to the face of the workpiece.

**GUARD.** You'll also want to check the guard. For safety, it's important that there's enough tension on the spring that the guard swings *all the way* back against the fence at the end of a cut, see Fig. 4. Note: Check your owner's manual to see how the tension is adjusted on your guard.

**V-BELT.** The last thing to do is to adjust the tension on the V-belt. The V-belt doesn't have to be "drum tight." To reduce the amount of vibration that's transferred to the jointer, I leave it loose enough to squeeze the belt together as shown in Fig. 5. 

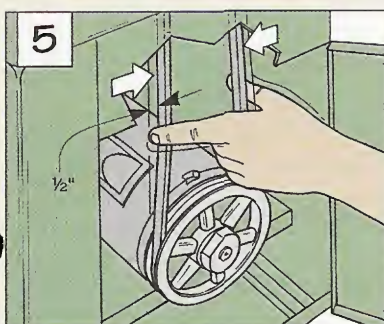
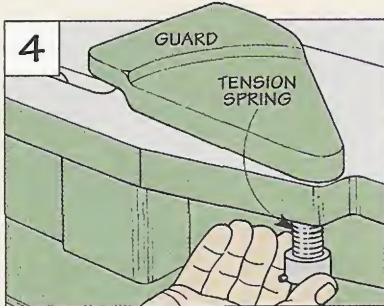

## Magna-Set

If you change jointer knives frequently, a Magna-Set will allow you to do it very quickly.

The Magna-Set consists of two plastic bars that rest on the outfeed table and a pair of metal rods that connect the bars, see drawing at right.

**MAGNET.** To position the knives level with the outfeed table, there's a magnet in each bar, see detail. The magnet holds the knives at the correct

height while you tighten the gib bolts.

Note: Reference lines on the fence make it easy to position the Magna-Set. (See page 31 for sources.)

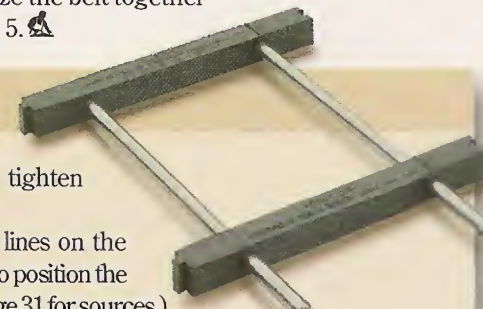
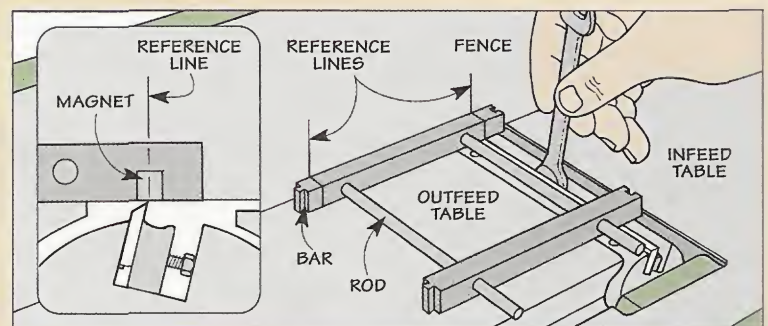

# Benchtop Jointer Extension Tables



A benchtop jointer is a versatile tool. It's lightweight, so it's easy to lift on and off a bench. And it leaves a smooth surface on a workpiece. But there *is* one drawback. The infeed and outfeed tables are too short to support a long workpiece.

An easy way to provide more support is to add an *extension table* to each end of the jointer, see photo above and drawing below.

**TABLES.** Each extension table is made up of a piece of  $\frac{3}{4}$ " MDF that's sandwiched between two layers of plastic laminate, see drawing at top of next page. To establish the width of the tables, just measure the width of the existing metal tables. But determining how *long* to make them isn't as cut and dried.

If the tables are too long, they're a hassle to work around. If they're too

short you're back to the same old problem. So I compromised and cut each *table* (A) 10" long. This may not sound like a lot. But when both tables are attached, the overall length of the bed is 50". That's *longer* than the bed on a typical 6" *stationary* jointer.

**PLASTIC LAMINATE.** Now you're ready to add the plastic laminate. It provides a durable surface that allows a board to slide smoothly across the table. Note: Covering both sides of the table with laminate will keep it flat with changes in humidity.

An easy way to apply the laminate is to start with oversize pieces and glue them on, one at a time. (I used contact cement.) A flush trim bit in a table-mounted router makes quick work of trimming the laminate flush with the table. Then repeat the process for the other pieces of laminate.

**CUT DADOES.** The next step is to cut two dadoes in the bottom of each table, see detail 'a' in drawing on page 25. These dadoes create a recess for a pair of threaded rods that will be used later when mounting the tables, see drawing at left.

**SUPPORT RAILS.** To support the tables, the rods fit through metal rails that are attached to the jointer.

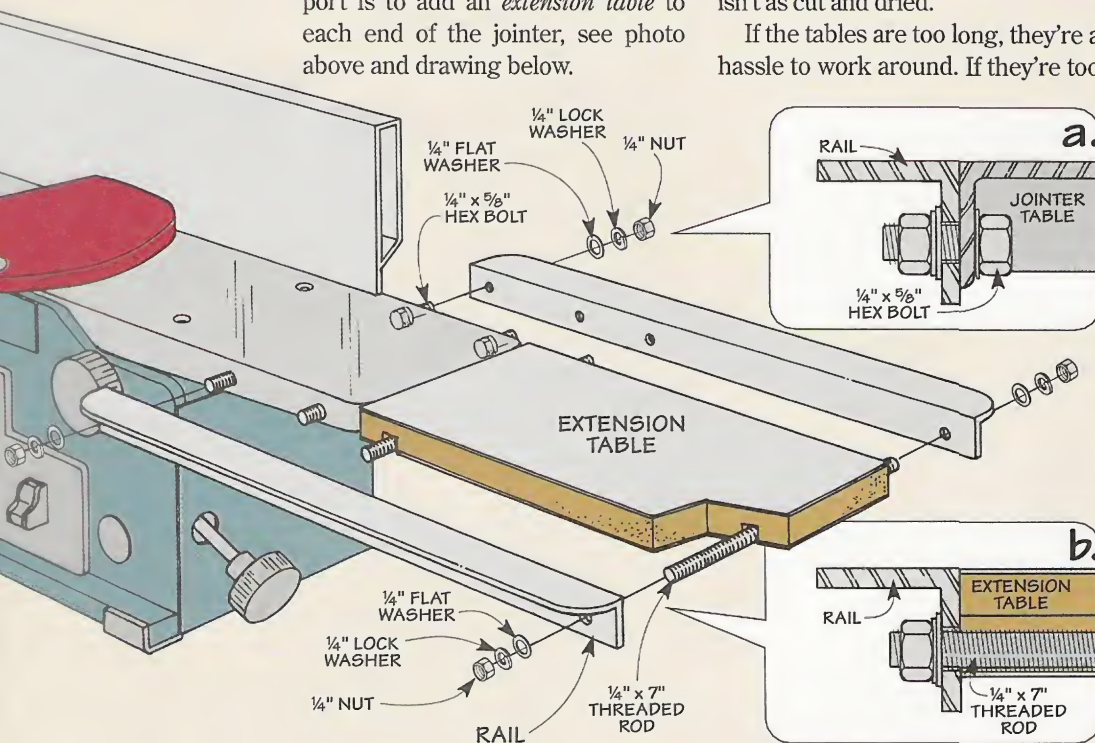



Each rail is just a short piece of aluminum angle, see drawing at right. Note: Make two rails for each table.

**MOUNTING HOLES.** After cutting the rails to length, you'll need to drill two pairs of mounting holes. Two of the holes allow the threaded rods to extend through the rails, see detail 'b' on opposite page. The other two accept bolts that are used to fasten the rails to the jointer, see detail 'a.'

To make the tables adjustable, all of these holes are drilled oversized. Also, you'll want to check that the mounting holes for the bolts won't interfere with any of the supporting ribs underneath the jointer.

**ROUND CORNERS.** Finally, to avoid catching the sharp corners of the rails, I used a sabre saw to round the

**NOTE:** MAKE TWO PAIRS OF RAILS. RAILS IN EACH PAIR ARE MIRROR IMAGES.

**NOTE:** MAKE TWO TABLES

outside corners. Then just sand the corners smooth.

**ATTACH TABLES.** At this point, all that's left is to attach the extension tables to the jointer, see Steps 1

through 3 below. The goal here is to get the tables perfectly flush with the infeed and outfeed tables of the jointer. This will ensure accurate cuts when jointing a workpiece. 

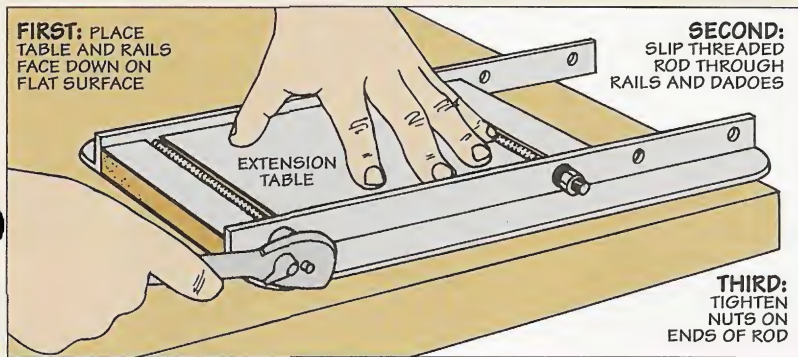
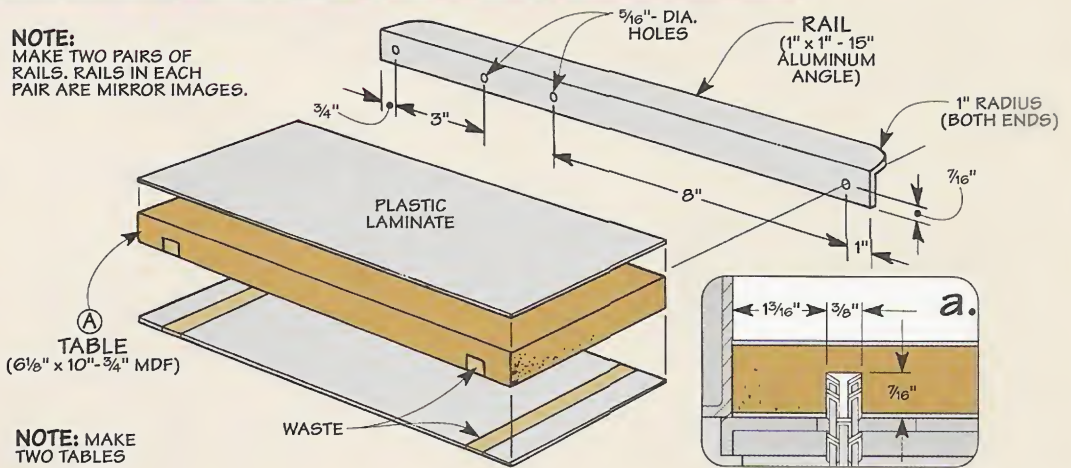

◀ **Step 1.** With the extension table face down on a flat surface, slip the threaded rods through the rails and dadoes. Then tighten a nut on each end of the rods to secure the rails. Note: To avoid bowing the table, be careful not to overtighten the nuts.

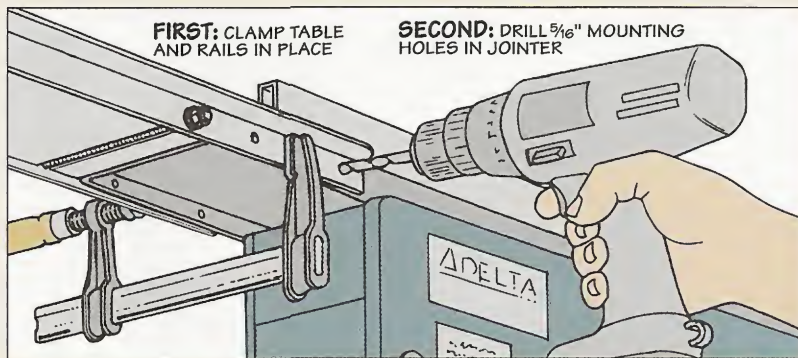

◀ **Step 2.** After slipping the open end of the rails around the metal table on the jointer, clamp the extension table in place so it's approximately level. Then use the mounting holes in the rail to locate and drill matching holes in the edge of the metal table.

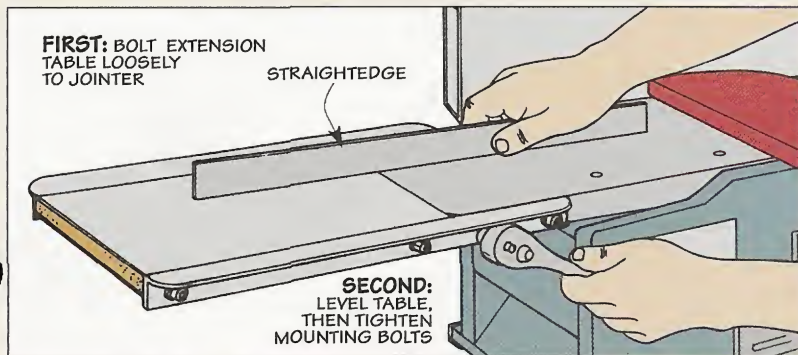

◀ **Step 3.** Finally, use a straightedge to ensure that the extension table is level with the metal table on the jointer. Once it's level, tighten the mounting bolts. Repeat these steps to install the other extension table.

# Benchtop Jointer Stand

*This shop-made stand converts your benchtop jointer into a stationary tool.*

It's amazing what a few strips of aluminum and a can of paint can do. Take this benchtop jointer stand for instance. At a glance, it appears to be a store-bought accessory for the jointer. But it's really just a simple, shop-made box.

Actually, there's more to this jointer stand than a nice paint job and some shiny metal strips.

**STABLE BASE.** For one thing, the stand provides a stable base that holds the jointer at a more comfortable working height than a bench. When you combine that with a pair of shop-made extension tables on the jointer, it's like having a full-size, stationary tool. (For step-by-step plans on building the extension tables, refer to the article on page 24.)

**CHIP COLLECTION.** But perhaps one of the handiest features on this jointer stand is something you don't even see until you open the door. The chips produced by the jointer fall into a plastic trash can that slides in

and out of the stand, see inset photo at right. When the trash can is full, you just remove it from the stand and throw the chips away.

**BASE.** The stand starts out as a tall base that's open on the top and end, see Fig. 1. I used  $\frac{3}{4}$ "-thick Medium-Density Fiberboard (MDF) because it's an inexpensive source of large, flat panels. Plus, MDF has a hard, smooth



surface that accepts paint well.

The base is made up of two *sides* (A) and a *back* (B) that are rabbeted to accept the *bottom* (C), see Fig. 1a. To strengthen the corners, I glued a couple of hardwood *cleats* (D) to each side piece, see Figs. 1 and 1b. The cleats in back provide a larger glue surface when the base is assembled. And the front cleats provide a mounting surface for a hinge and some catches that are added later.

**ALUMINUM ANGLE.** After gluing and clamping the base together, the next step is to add a piece of aluminum angle to each corner. (You can find aluminum angle at most home centers.)

Besides covering the exposed edges of the base, the pieces of angle protect the corners of the stand from getting chipped. In addition, they add extra rigidity to the stand.

The aluminum angle is held in place with screws. But before installing it, you may want to shine it up by removing the scratches and

## Materials & Hardware

### Base

A Sides (2)	28 $\frac{1}{2}$ x 25 $\frac{1}{4}$ - $\frac{3}{4}$ MDF
B Back (1)	15 $\frac{1}{4}$ x 25 $\frac{1}{4}$ - $\frac{3}{4}$ MDF
C Bottom (1)	14 $\frac{1}{4}$ x 28 $\frac{3}{4}$ - $\frac{3}{4}$ MDF
D Cleats (4)	$\frac{5}{8}$ x 1 $\frac{3}{4}$ - 24 $\frac{1}{2}$
E Door (1)	11 $\frac{3}{4}$ x 24 $\frac{3}{8}$ - $\frac{3}{4}$ MDF
F Edging Strip (1)	$\frac{3}{4}$ x $\frac{1}{2}$ - 24 $\frac{3}{8}$
G Holder (1)	$\frac{3}{4}$ x 1 $\frac{1}{2}$ - 12 $\frac{1}{2}$

### Top

H Top (1)	16 x 30 - $\frac{3}{4}$ MDF
I Supt. Strip (3)	1 $\frac{3}{8}$ x Cust. Length - $\frac{1}{4}$ Hdbd.
J Spacer (1)	$\frac{1}{2}$ x 1 - Cust. Length

### Cover

K Sides (2)	$\frac{1}{2}$ x 3 $\frac{1}{2}$ - 4 $\frac{1}{4}$
L Top Cover (1)	2 $\frac{1}{16}$ x 8 $\frac{3}{8}$ - $\frac{1}{4}$ Hdbd.
M Bottom Cover (1)	2 $\frac{3}{16}$ x 8 $\frac{3}{8}$ - $\frac{1}{4}$ Hdbd.
N Middle Cover (1)	2 $\frac{5}{16}$ x 8 $\frac{3}{8}$ - $\frac{1}{4}$ Hdbd.

- (4) 1 $\frac{1}{2}$ " x 1 $\frac{1}{2}$ " - 25 $\frac{1}{4}$ " Alum. Angle
- (2) 1" x 1" - 3 $\frac{5}{8}$ " Alum. Angle
- (4) Leg Levelers w/screws
- (1) 1 $\frac{1}{16}$ " x 24 $\frac{3}{8}$ " Continuous Hinge
- (1) 4 $\frac{7}{8}$ " Drawer Pull
- (2) Magnetic Catches w/Strikes
- (8) #8 x  $\frac{1}{2}$ " Fh Sheet Metal Screws
- (40) #8 x 1 $\frac{1}{4}$ " Fh Sheet Metal Screws
- (6) #8 x 2" Fh Sheet Metal Screws
- (4)  $\frac{1}{4}$ " x 1 $\frac{1}{2}$ " Hex Bolts
- (4)  $\frac{1}{4}$ " T-nuts
- (4)  $\frac{1}{4}$ " Washers
- (1) Trash Can (36 Quart)

Note: For a source of the heavy-duty leg levelers we used on this jointer stand, see Sources on page 31.

mill marks. (For more on working with aluminum, refer to page 29.)

**LEG LEVELERS.** To prevent the stand from wobbling if the floor is uneven, I added four sturdy leg levelers, see Fig. 2. These levelers wrap around the bottom edge of the sides and are simply screwed in place, see page 31 for Sources.

One nice thing about the levelers is they have a large, metal “foot” that serves as a stable platform. To raise and lower the foot, it’s attached to a threaded rod which adjusts with an ordinary Allen wrench.

**DOOR.** With the levelers in place, I added a *door* (E) to enclose the front of the stand, see Fig. 2. When determining the size of the door, there are several things to keep in mind.

First, to provide a mounting surface for the hinge, a 1/2"-wide wood strip will be attached to the door, see Fig. 2a. You’ll also need to account for the thickness of the hinge itself.

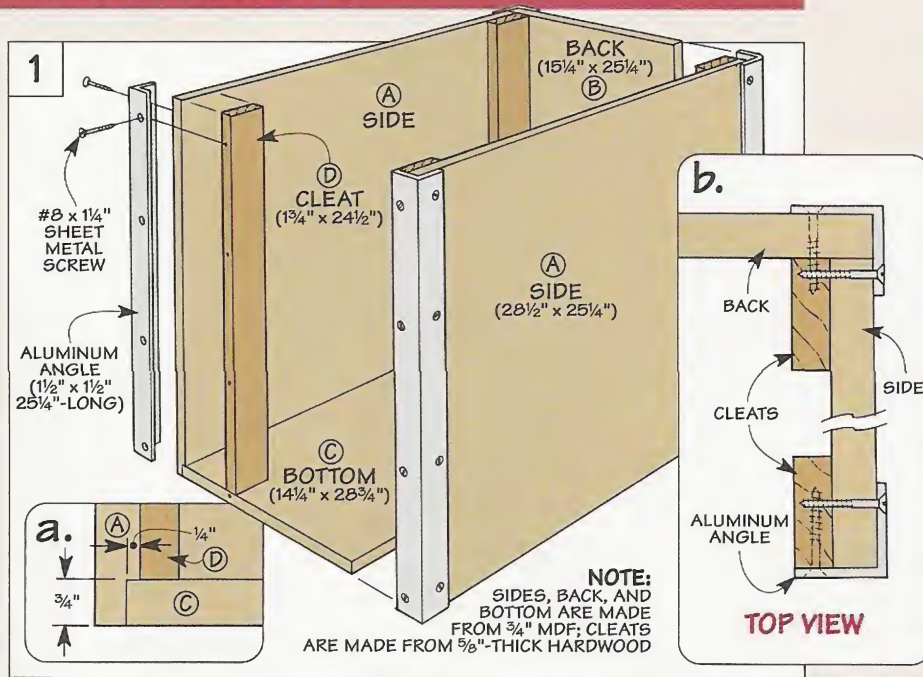

Finally, don’t forget to allow for a 1/16" gap between the other three edges of the door and the stand.

**EDGING STRIP.** After cutting the door to size, you can add the *edging*

*strip* (F), see Fig. 2. It’s a piece of hardwood glued to the edge of the door. When the glue dries, it’s just a matter of hinging the door to the stand.

**CATCHES.** To hold the door closed, the cleat on the opposite side of the hinge provides a mounting surface for a pair of magnetic catches. After installing the catches, I screwed the strike plates to the back of the door and fastened a small drawer pull to the front.

**PUSH BLOCK HOLDER.** As an option, you may want to install a holder for your push blocks. I attached the holder to the back of the jointer stand, see photo at right. Now when I’m ready to joint a workpiece, the push blocks are just a short reach away.

The *holder* (G) is a strip of hardwood that fits between the pieces of aluminum angle on the corners of the stand, see Fig. 3. To prevent the push blocks from falling out, there’s a lip that’s formed by rabbeting the top edge of the holder, see Fig. 3a.

The rabbet is sized in depth to match the thickness of the *base* of the push block. This way, you can slip the push block down into the rabbet and “wedge” it in place. To attach the holder to the stand, it’s simply screwed in place.



▲ A hardwood strip screwed to the back of the stand provides a handy way to store push blocks.

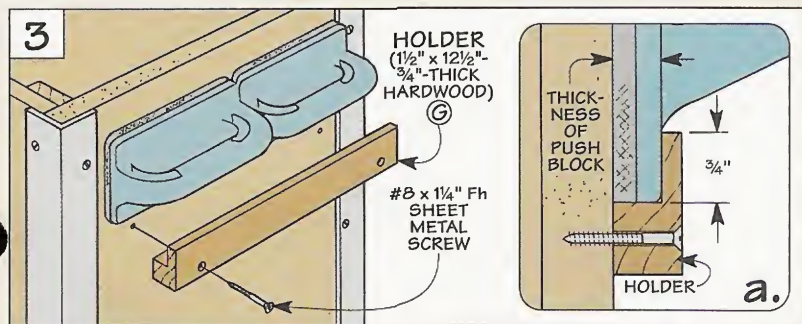
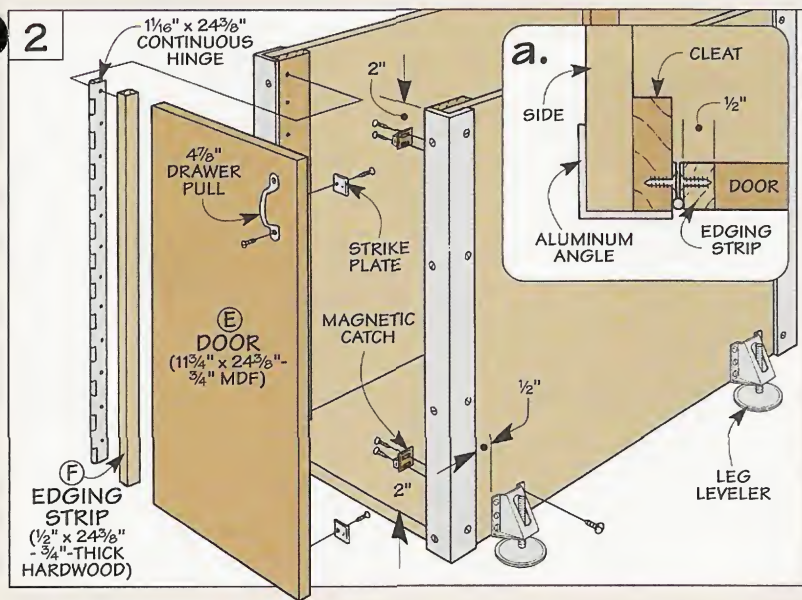

# Top

With the base complete, I added a top. It provides a solid mounting platform for the jointer, see Fig. 4. In addition, the top holds a cover that encloses the chip chute on the jointer.

**TOP.** The top (H) is a large, MDF panel that's sized to overhang all four edges of the base. To ease the sharp corners of the panel, I routed a slight ( $\frac{1}{16}$ " ) chamfer on the top and bottom edges, see Fig. 5a.

**CUT OPENING.** To allow chips to fall into the trash can, there's a rectangular opening in the top. Note: The size and location of this opening may vary depending on your jointer.

An easy way to determine the location is to position the jointer on the top. I centered it on the width of the top. But to end up with an opening directly over the trash can, the jointer is offset toward one end.

At this point, it's just a matter of laying out the opening right below the chip chute on the jointer. Then, after drilling a starter hole near each corner of the opening, remove the rest of the waste with a sabre saw.

**MOUNTING HOLES.** Once the opening is completed, it's a good time to locate the mounting holes for the jointer. The idea here is to set the jointer in place so the chip chute aligns with the edge of the opening. This allows chips to fall into the trash

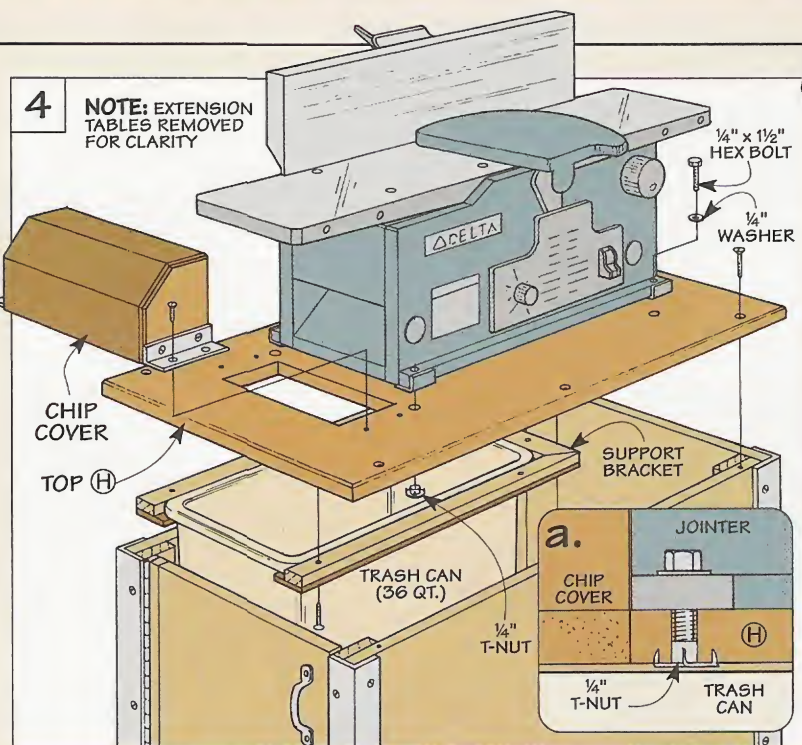

can without piling up on the top.

Now you can mark and drill the mounting holes. The holes are sized to accept the barrel of a T-nut that's installed from underneath, see Fig. 4a. Later, the T-nuts make it easy to bolt the jointer to the top of the stand.

**SUPPORT BRACKET.** There's one last thing to do before attaching the top to the stand. That's to add a U-shaped support bracket underneath the top, see Fig. 4. The support bracket suspends the trash can

below the chip opening. It also guides the trash can as you slide it in and out of the stand. Note: I used a plastic trash can (36-quart).

The support bracket eventually ends up as three separate parts to form the U-shape. Each part is made up of two pieces: a  $\frac{1}{4}$ " hardboard support strip (I) and a spacer (J) made of hardwood, see Fig. 5.

To form a lip that holds the rim of the trash can, the support strip is wider than the spacer, see Fig. 5a. Also, I planed the spacer so it's slightly thicker than the height of the rim. This allows the trash can to slide in and out without binding. (In my case, the spacer was  $\frac{1}{2}$ " thick.)

After gluing the support strip and spacer together, the next step is to miter the three pieces of the bracket to length to fit around the trash can.

**MOUNT BRACKET.** Now you're ready to mount the support bracket to the top. To position the bracket, it's easiest to turn the top upside down and place the trash can over the chip opening. Then set each of the bracket pieces lightly against the trash can.

Before screwing them to the top, you'll want to make sure the ends of the bracket are far enough in to

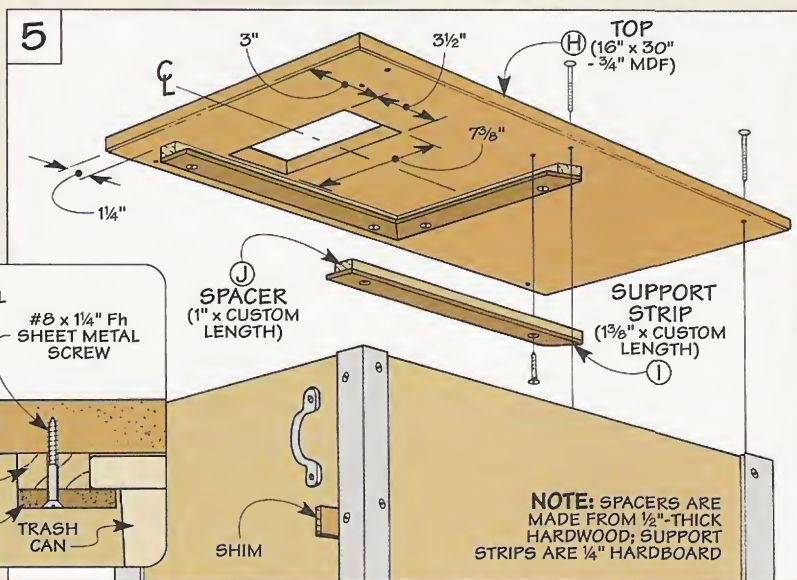

allow the door to close. (I set the bracket 1 1/4" in from the end.)

**ATTACH TOP.** The next step is to attach the top. It's held in place with screws. But the thing to watch is that the door doesn't rack in the process. So to maintain a consistent gap, I shimmed the door and then screwed the top to the stand.

**CHIP COVER.** All that's left to complete the stand is to add a chip cover. To avoid having chips spill out on the stand, this cover encloses the chip chute on the jointer and the opening in the top.

The two *sides* (K) of the cover are small, hardwood blocks with the corner trimmed at an angle, see Figs. 6 and 6a. To enclose the sides, they're wrapped with three hardboard cover pieces. The inside edge of the *top* (L) and *bottom cover* (M) is

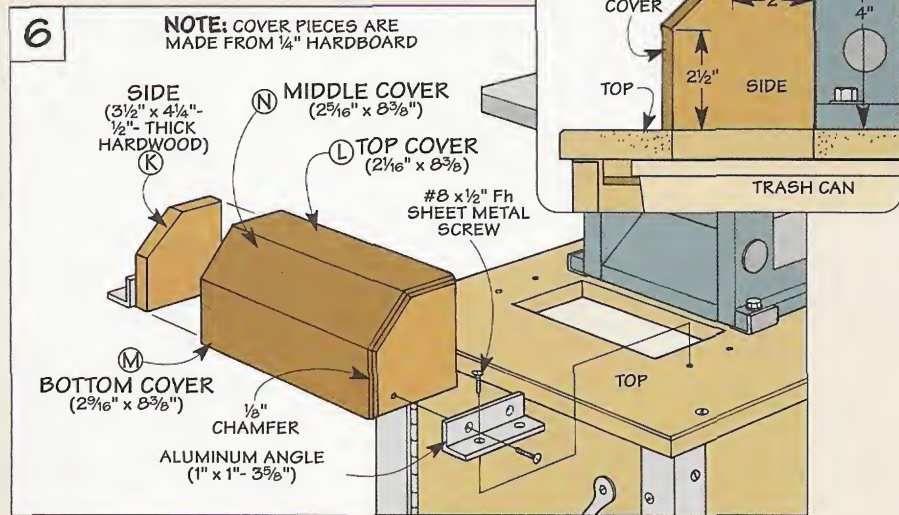

beveled before gluing them to the sides. Then the *middle cover* (N) is beveled on both edges to fit between.

**MOUNT JOINTER & COVER.** After routing a chamfer on the ends of the

cover, it's just a matter of bolting the jointer to the stand, see Fig. 4a. Then butt the cover against the jointer and attach it with short pieces of aluminum angle and screws. 

**BEFORE** ▼

## Working With Aluminum

I use aluminum angle quite frequently on my shop projects. It's readily available at most home centers. And it's relatively inexpensive.

The only problem is that right out of the store, the aluminum is a bit scruffy looking. It has scratches and scuff marks, not to mention the machining marks left from the mill, see upper photo at right.

So I decided to "clean up" the

aluminum angle that's used on the jointer stand as well as the extension tables featured on page 24.

**SAND.** To create a clean, smooth surface, the first step is to sand the aluminum, see Step 1. I started with 100-grit sandpaper and then continued on with 150, 180, and 220-grits.

**BUFF.** At this point, the aluminum is quite smooth. But to give

it a nice, soft sheen, I buffed it with an abrasive pad, see Step 2.

After getting the aluminum all buffed out, I noticed that every time I touched it, I left a fingerprint behind. So to keep the aluminum looking nice, I wiped all the surfaces down with mineral spirits. Then I sprayed on a coat of clear lacquer, see Step 3.



**1** After cutting the pieces of aluminum angle to length, sand the surfaces smooth using progressively finer grits of sandpaper.



**2** To create a satin smooth finish, buff the surface of the aluminum with a nylon abrasive pad. I used a gray (#00) pad.



**3** After wiping down the aluminum with mineral spirits, spray on a couple coats of clear lacquer for protection.

▲ **AFTER**

# Tool Talk

TOOLS OF THE TRADE

## Three-Point Turning Tool

■ At first glance, this *three-point tool* doesn't look like a turning tool. In fact, it looks more like a railroad spike with a wood handle. (Take a look at the photo on page 31.)

In spite of that, it's a handy tool to have when turning a spindle. The three-point tool is designed to make the same types of cuts as a skew chisel. That's what intrigued me about it. (I've "caught" the edge of a skew chisel and ruined a spindle on more than one occasion.)

**THREE FACETS.** Now I'm not sure where the word "point" comes from. The three-point tool actually has three separate *facets*, each with its own cutting edge. (You can see the facets in the inset photo at right.)

These cutting edges produce extremely fine shavings, see photo above. And the 1/2"-dia. solid steel rod that forms the blade has a nice heft to it. That gives the tool a good, solid feel when I'm planing a surface smooth or squaring up the end of a spindle.

**TURNING A BEAD.** But the thing that impressed me most about this three-point tool is it makes it easy to turn a bead. Because of the shape of the tip, the cutting edges



don't have a tendency to "dig in" like a skew chisel. And the surface of the bead is almost (but not quite) as smooth as I can get with a skew chisel.

The only drawback to a three-point tool is I can't turn as *delicate* a bead as I'd like. Since the tip of the tool is quite thick, the initial cuts that form the sides of the bead are *wider* than I can make with a skew chisel. As a result, the beads have gently sloping sides. This also means I can't locate beads as close together as with a skew chisel.

## Band Saw Roller Bearings

■ When making a curved cut on the band saw, the blade deflects as you pivot the workpiece. The metal guide blocks on the saw minimize this deflection. But when the blade contacts the guide blocks, the heat that builds up can shorten the life of the blade. (You can see "wear marks" on the dark-colored guide blocks shown at left.)

**ROLLER BEARINGS.** To support the blade *without* producing as much heat, you can replace the guide blocks with roller bearings. There are a couple of different types of roller bearings available. But one of the simplest types I've seen is the *Bandrollers* shown in the inset photo at right.

Each *Bandroller* is an aluminum block with two bearings attached to the end. Note: If you purchase *Bandrollers* for a Delta band saw, the end of one block will be angled like the guide block on the Delta, see margin.

**INSTALLATION.** There's nothing complicated about installing *Bandrollers*. You just remove the metal guide blocks from the saw and replace them with the roller bearings. I did have a little trouble getting one of the roller bearings to fit though. But with just a bit of sanding, it slid right in.

**ADJUSTMENT.** Once the *Bandrollers* are installed, there are two different methods for adjusting them. One way is to adjust them like you would metal guide blocks. To do that, leave a slight gap (about the thickness of a sheet of paper) between the bearings and the blade.

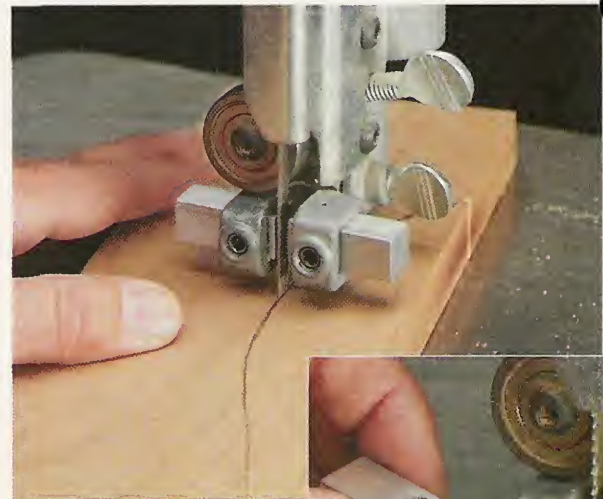

The second method is to slide the *Bandrollers* in so the bearings press *lightly* against the blade.

This method provides more support for the blade. But since the bearings will be spinning constantly, they could wear out sooner. So I'd only use it when making a controlled cut is really critical.

**COST.** One final note. Our set of *Bandrollers* cost \$60.00. (See next page for sources.) That's a little pricey. But it's considerably less than other after-market roller bearings.



▲ These *Bandrollers* and the guide blocks they replace both provide support for a band saw blade. But the bearings roll smoothly without heating up.

# Sources

## PRODUCT INFORMATION



### ▲ Three-Point Turning Tool

The three-point turning tool that's featured on page 30 is designed to make the same types of cuts as a skew chisel. You can use it to make a planing cut, square up the end of a spindle, or turn a bead.

There are two sizes of three-point tools available. The tool shown above has a 1/2"-dia. blade. But 3/8"-dia. blades are also available. You can order three-point tools (also called round-point tools) from the mail-order sources listed in the margin.

## MAIL ORDER SOURCES

**Highland Hardware**  
800-241-6748  
*Bandrollers, Magna-Set*

**Packard Woodworks, Inc.**  
800-683-8876  
*Three-Point Tool*

**Woodcraft**  
800-225-1153  
*Bandrollers, Magna-Set, Three-Point Tool*

**Woodsmith Store**  
800-835-5084  
*Magna-Set, Honing Guide*

**Woodworker's Supply, Inc.**  
800-645-9292  
*Honing Guide*

**ShopNotes Project Supplies** is offering some of the hardware and supplies needed to build the projects in this issue. We've also put together a list of other mail-order sources that have similar hardware and supplies.



### ▲ Magna-Set

A Magna-Set (page 23) lets you set the knives on a jointer quickly and accurately. The knives are positioned by means of a magnet housed in the bars of the Magna-Set, see margin for sources.



### ▲ Jointer Honing Guide

This Honing Guide (page 22) holds two sharpening stones (180-grit and 400-grit) that make it easy to restore a dull edge on your jointer knives. For sources of this Honing Guide, see margin.

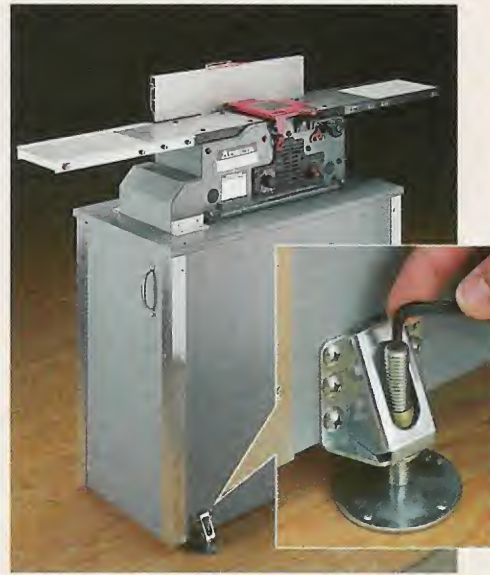

### ▲ Heavy-Duty Base Levelers

To prevent the Jointer Stand that's featured on page 26 from wobbling if the floor is uneven, we installed heavy-duty *base levelers*. Each leveler has a large "foot" that creates a stable platform for the tool stand. You can adjust the foot up or down by using an Allen wrench to turn a threaded post, see inset photo above. Base levelers are available in pairs from *ShopNotes Project Supplies*.

**HEAVY-DUTY BASE LEVELERS**  
1008306.....\$19.95 per pair

#### STATEMENT OF OWNERSHIP, MANAGEMENT, AND CIRCULATION (Required by 39 U.S.C. 3685)

1. Publication Title: ShopNotes. 2. Publication No.: 1042-9696 3. Filing Date: September 1, 1999. 4. Issue Frequency: Bimonthly. 5. No. of issues published annually: 6 (six). 6. Annual subscription price: \$21.94. 7. Complete mailing address of known office of publication: 2200 Grand Avenue, Des Moines, (Polk County), Iowa 50312-5306. 8. Complete mailing address of the headquarters or general business offices of the publisher: 2200 Grand Avenue, Des Moines, (Polk County), Iowa 50312-5306. 9. Full names and complete mailing addresses of publisher, editor, and managing editor: Publisher: Donald B. Peschke, 2200 Grand Avenue, Des Moines, Iowa 50312; Editor: Tim Robertson, 2200 Grand Avenue, Des Moines, Iowa 50312. 10. Owner: August Home Publishing Company, 2200 Grand Avenue, Des Moines, Iowa 50312; Donald B. Peschke, 2200 Grand Avenue, Des Moines, Iowa 50312. 11. Known bondholders, mortgagees, and other security holders owning 1 percent or more of total amount of bonds, mortgages or other securities: None. 12. (Does not apply.) 13. Publication Title: ShopNotes. 14. Issue Date for Circulation Data Below: July/Aug 1999 (P46) 15. Extent and nature of circulation:

	Average no. copies each issue during preceding 12 months	Average no. copies of single issue published nearest to filing date
A. Total number of copies (not press run).....	201,518	188,506
B. Paid and/or requested circulation:		
1. Paid/requested outside-county mail subscriptions started on Form 3541 .....	157,553	145,241
2. Paid in-county subscriptions .....	0	0
3. Sales through dealers and carriers, street vendors, counter sales, and other non-USPS paid distribution .....	16,034	13,879
4. Other classes mailed through the USPS .....	0	0
C. Total paid and/or requested circulation .....	173,587	159,220
D. Free distribution by mail, samples, complimentary, and other free copies:		
1. Outside-county as stated on Form 3541 .....	161	133
2. In-county as stated on Form 3541 .....	0	0
3. Other classes mailed through the USPS .....	0	0
E. Free distribution outside the mail (carriers or other means) .....	0	0
F. Total free distribution .....	161	133
G. Total distribution .....	173,748	159,353
H. Copies not distributed .....	27,770	29,153
I. Total .....	201,518	188,506
J. Percentage Paid and/or requested circulation .....	99.91%	99.92%
16. Publication of Statement of Ownership: Will be printed in the Nov./Dec. 1999 (P46) issue of this publication.		
17. I certify that all information furnished on this form is true and complete. (Signed) Tim Robertson, Editor		

On occasion, we allow companies whose products and services may be of interest to you to send advertising mail to our subscribers. We are careful to choose ethical companies that have information of genuine interest to our subscribers. Most of our subscribers appreciate receiving these materials. However, if you prefer to have your name deleted from the mailing list made available to other companies, please write to us at ShopNotes, 2200 Grand Avenue, Des Moines, IA 50312

### WoodNet

- 101 Woodworking Tips Online
  - Woodworking Techniques
  - Project plans you can download
  - WoodNet Forum
  - Power Tool Reviews
- [www.augusthome.com](http://www.augusthome.com)

#### ON-LINE CUSTOMER SERVICE

- Access information about your subscription account.
  - Find out if your payment has been received.
  - Change your mailing address or your e-mail address.
  - Let us know if you haven't received your issue.
- [www.shopnotes.com](http://www.shopnotes.com)

TO PLACE AN ORDER CALL  
**800-347-5105**  
(KEY CODE: SN 48)

## Scenes from the Shop

Built in 1914 by the J. D. Wallace Company, this heavy-duty jointer features a unique aluminum guard that covers the exposed knives. The fence is supported by the

motor housing, and a lever locks it at the desired angle. With a direct-drive motor that spins the cutterhead, this jointer is still providing reliable service today.

