

ShopNotes®

Vol. 9

Issue 50

Table Saw Workstation



Features:

- ◆ Fold-Up Outfeed Table
- ◆ Roll-Around Storage Cabinets
- ◆ Space-Saving Router Table Extension

- Tongue & Groove Joinery
- Router Table Tips
- Table Saw Upgrade: Precision T-Square Rip Fence



ShopNotes®

Issue 50

March 2000

PUBLISHER Donald B. Peschke

EDITOR Tim Robertson

ASSOCIATE EDITOR Tom Begnal

ASSISTANT EDITOR Bryan Nelson

ART DIRECTOR Cary Christensen

SR. GRAPHIC DESIGNER Kurt Schultz

SENIOR ILLUSTRATORS Roger Reiland

Mark Higdon

CREATIVE RESOURCES

Creative Director: Ted Kralicek • *Project Developer:* Ken Munkel • *Senior Project Designer:* Kevin Boyle • *Project Coordinator:* Kent Welsh • *Shop Manager:* Steve Curtis • *Shop Craftsman:* Steve Johnson • *Senior Photographer:* Crayola England

SPECIAL PUBLICATIONS

Executive Editor: Douglas L. Hicks • *Art Director:* Steve Lueder • *Sr. Graphic Designers:* Chris Glowacki, Cheryl L. Simpson • *Asst. Editors:* Joe Irwin, Craig Rueggsegger • *Graphic Designer:* Vu Nguyen

CIRCULATION

Sub. Serv. Dir.: Sandy Baum • *New Bus. Dir.:* Glenda Battles • *Circ. Marketing Analyst:* Kris Schlemmer • *Creative Mgr.:* Melinda Haffner • *Renewal Mgr.:* Paige Rogers • *Sr. Graphic Designer:* Mark Hayes • *Billing Mgr.:* Rebecca Cunningham • *Prom. Mgr.:* Rick Junkins • *New Bus. Mgr.:* Todd L. Bierle • *Asst. Sub. Mgr.:* Joy Krause

CORPORATE SERVICES

Controller: Robin Hutchinson • *Sr. Accountant:* Laura Thomas • *Accounts Payable:* Mary Schultz • *Accounts Receivable:* Margo Petrus • *Prod. Dir.:* George Chmielarz • *Electronic Pub. Dir.:* Douglas M. Lidster • *Network Admin.:* Cris Schwanebeck • *Prod. Assistant:* Susan Rueye • *Pre-Press Image Specialist:* Troy Clark, Minnette Johnson • *New Media Manager:* Gordon C. Gaippe • *Multimedia Art Dir.:* Eugene Pedersen • *Technology Analyst:* Carol Schoeppler • *Web Site Product Specialist:* Adam Best • *Web Content Manager:* Terry Walker • *H. R. Asst.:* Kirsten Koele • *Facilities Mgr.:* Julia Fish • *Administrative Asst.:* Sherri Ribbey • *Receptionist:* Jeanne Johnson • *Mail Room Clerk:* Lou Webber • *Building Maintenance:* Ken Griffith

MAIL ORDER

Operations Dir.: Bob Baker • *Cust. Serv. Mgr.:* Jennie Enos • *Warehouse Supr.:* Nancy Johnson • *Buyer:* Linda Jones • *Admin. Asst.:* Nancy Downey • *Tech. Rep.:* John Audette • *Cust. Serv. Reps.:* Anna Cox, Tammy Truckenbrod, Deborah Rich, April Revell • *Warehouse:* Sylvia Carey, Dan Spidle, Sheryl Knox

WOODSMITH STORE

Manager: Dave Larson • *Sales Staff:* Wendell Stone, Jim Barnett, Kathy Smith, Larry Morrison, Harold Cashman, Tim Rundell, Tim Thelen • *Office Manager:* Vicki Edwards

ShopNotes® (ISSN 1062-9696) is published bimonthly (Jan., March, May, July, Sept., Nov.) by August Home Publishing, 2200 Grand, Des Moines, IA 50312.

ShopNotes® is a registered trademark of August Home Publishing ©Copyright 2000 by August Home Publishing. All rights reserved.

Subscriptions: Single copy: \$4.95. One year subscription (6 issues), \$21.94. Canada/International add \$10 per year, U.S. funds.

Periodicals Postage Paid at Des Moines, IA and at additional mailing offices.

Postmaster: Send change of address to ShopNotes, P.O. Box 37103, Boone, IA 50037-2103.

Subscription Questions? Write to: ShopNotes Customer Service, P.O. Box 842, Des Moines, IA 50304-9961. Or call 1-800-333-5854, 8:00 am to 5:00 pm, Central Time, weekdays. FAX 515-283-0447

E-Mail: ShopNotes@shopnotes.com

Internet: http://www.shopnotes.com

PRINTED IN U.S.A.

EDITOR'S NOTE

Cutoffs

One of the things I enjoy most about visiting other woodworkers' shops is it always seems to trigger a new idea.

Sometimes it's a clever jig or a handy storage solution. Other times I come away with a great new tip.

Well, recently I was poking around Ted's shop. (Ted is our creative director.) It's nothing fancy really, just a basement shop with concrete block walls and fluorescent lights. But there's one thing that caught my eye right away.

WORKSTATION. Sitting smack-dab in the middle of the shop is what Ted calls a *workstation*. To tell you the truth, I'm not so sure it isn't more of a *play area*. But no matter what you call it, the whole thing is centered around his table saw.

Mounted to the table saw is a heavy-duty rip fence and large extension wing. Together with a removable out-feed support, they make it easy to rip wide sheets of material.

Now that would be a major improvement all by itself. But there's more. To save space, the wing doubles as a router table with an adjustable fence. And a cabinet that helps support the wing provides extra storage underneath.

All in all, Ted's workstation seemed like a great idea — a single, self-contained unit that accomplished a variety of jobs. In fact, it seemed like an ideal project to feature in *ShopNotes*.

So we kicked the idea around, made a few changes and improvements, and built our own version. (To see how it turned out, take a look at the front cover.)

Now I realize that this may seem like a large, ambitious project. But it's really not. Actually, it's a collection of *three* separate projects: a set of roll-around cabinets, a router table extension, and an out-

feed table. This makes it easy to modify the workstation to fit your needs. You can build all three of the projects, or just one. No matter what, it's sure to make a great addition to your shop. (We've included a series of articles with step-by-step instructions for building each part of the workstation beginning on page 6.)

THE WORKSHOP

The table saw workstation is a good example of how a visit to just one shop can "mushroom" into a great project that may benefit thousands of woodworkers.

That got me thinking about something new I'd like to try in *ShopNotes*.

The idea is to visit other woodworkers' shops and then feature a number of those shops in our upcoming issues.

But in order to make this work, I need your help. If you'd like us to visit your shop (or you know someone who has an interesting shop), give us a "sneak preview" of it by sending a few photos and a brief description.

Keep in mind that it doesn't have to be a big, fancy shop. In fact, maybe it's just like Ted's shop, and it only occupies a small area in the basement.

If this sounds like something you're interested in, send a peek of your shop to: *ShopNotes* (Attn.: Tim Robertson), 2200 Grand Ave., Des Moines, IA 50312.

HELP WANTED

One final note. We're looking for editors, illustrators, and graphic designers who are enthusiastic about woodworking and home improvement to join us here at August Home Publishing. If you're interested in any of these positions, send a letter and resume to: S. Ribbey, 2200 Grand Ave., Des Moines, IA 50312.

Tim

Contents

Features

Table Saw Workstation _____ 6

A table saw is one of the most versatile tools in a shop. Now you can make it even better. Here's a quick overview of three great projects we're featuring in this issue that will convert your table saw into a complete workstation.

Router Table Extension _____ 8

This router table replaces the extension wing on your table saw. Besides saving space, a lift-out insert plate, miter gauge slot, and adjustable fence make it extremely versatile as well.

Table Saw Cabinets _____ 16

Add weight and stability to your table saw by mounting it to these roll-around cabinets. Then enjoy the storage, mobility, and built-in dust collection they provide.

Tongue & Groove Joinery _____ 24

A tongue and groove joint is an ideal solution when it comes to joining solid wood and plywood. We show you a few simple tricks to cut these joints quickly and accurately.

Fold-Up Outfeed Table _____ 26

If you're ripping long boards, it only takes a second to hook this outfeed table onto the table saw. Plus, its unique design lets you fold the table for storage.

Departments

Readers' Tips _____ 4

Our readers offer their own shop-tested tips dealing with some of the most common woodworking problems.

Router Table Tips _____ 14

Five great tips to get the most out of your router table.

Tool Talk _____ 30

Tips and talk about tools of our trade. In this issue, we take a look at a precision, T-square rip fence for your table saw.

Sources _____ 31

Hardware, supplies, and mail-order sources for the projects featured in this issue.

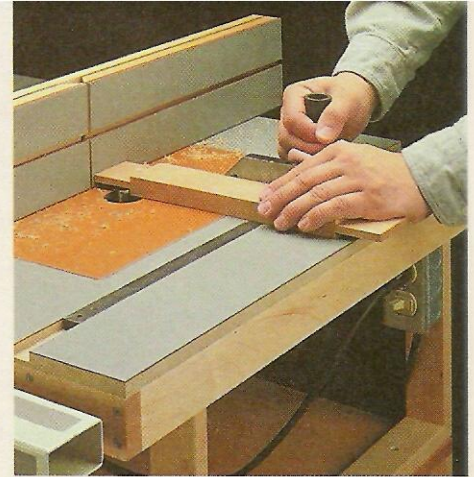

Router Table Extension page 8

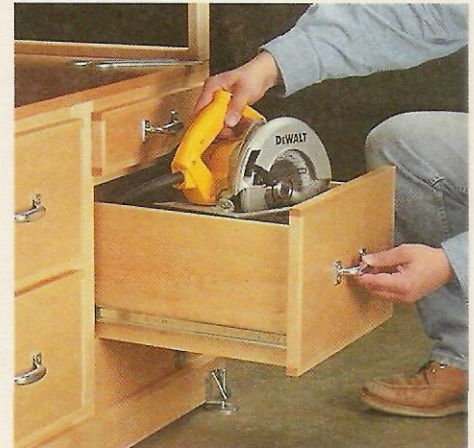
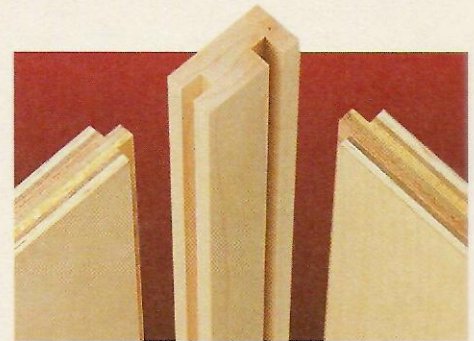

Table Saw Cabinets page 16



Tongue & Groove page 24



Fold-Up Outfeed Table page 26

Readers' Tips

Magnetic Featherboard

■ Sometimes clamping a featherboard to the table saw is more trouble than it's worth. The cast ribs underneath the saw table always get in the way of the clamps. And when I need to move the featherboard just a hair, it's a nuisance to reposition the clamps.

To help simplify things, I made a magnetic featherboard that attaches to the table saw in seconds, see photo. The key to this featherboard is a pair of magnetic bases like the kind

used to hold a dial indicator, see photo at left and Sources on page 31.

The unusual thing about these bases is that each one has a switch that lets you turn the magnetic field on or off. Once the featherboard is in position, you simply flip on both switches to secure it to the saw table. To reposition (or remove) the featherboard, just turn the switches off.

To make this work, the featherboard is attached to an L-shaped support, see drawing. After cutting an angled notch to fit the feather-

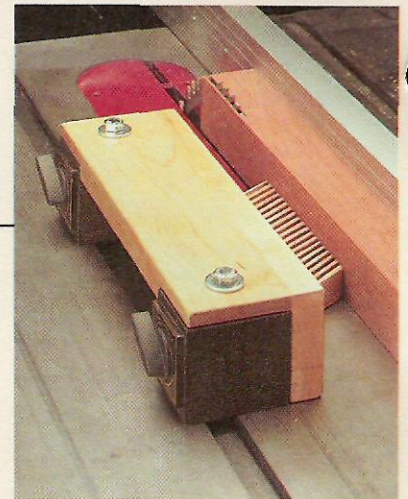

board, I rabbeted each end of the top to fit the magnetic bases. A threaded hole in the top of each base makes it easy to bolt them to the support.

*Stephen Wysocki
Grand Terrace, California*

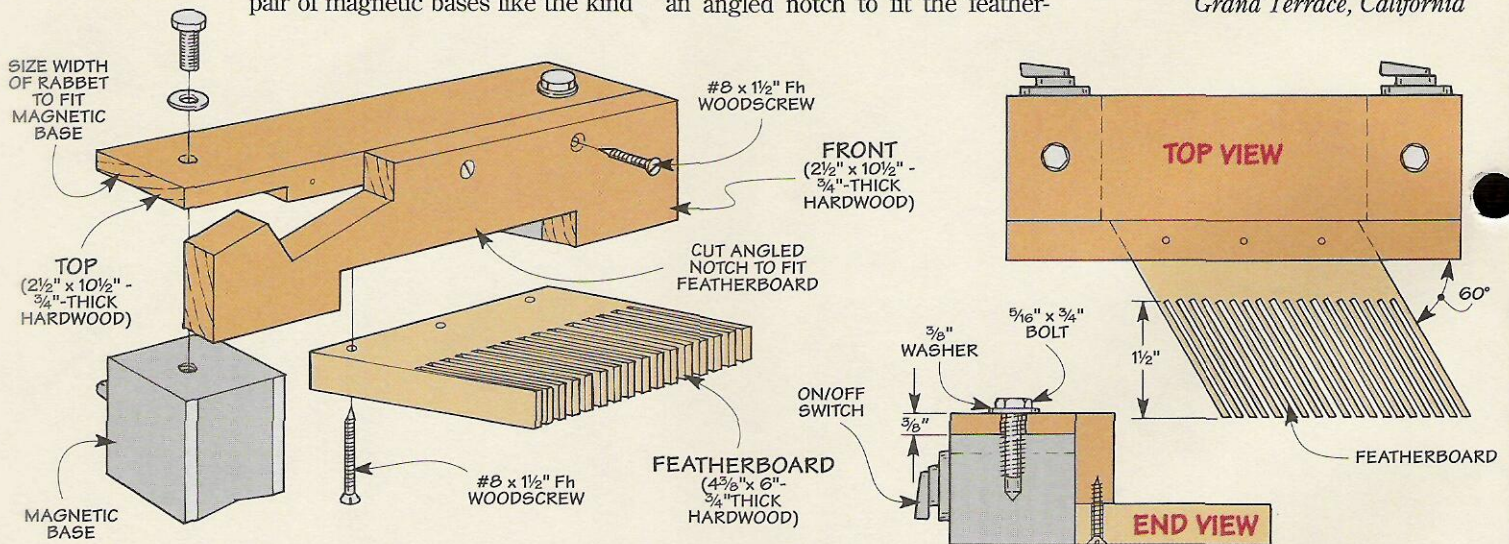

Quick Tips



▲ There's more than one way to keep a nut from vibrating loose from a bolt. In a pinch, **Joe Strongbow** of Austin, TX uses a dab of hot glue to "lock" the nut on the bolt.



▲ When adjusting a tool, it only takes a second for **Jim Wheeler** of Plainfield, IN to find the correct Allen wrench. That's because it's painted to match the adjustment screw.



▲ The exhaust port on a shop vacuum often stirs up a lot of dust. So **Erik Mason** of Fleurimont, Quebec installs a plastic 90° elbow to direct the air straight up.

Swing-Out Tool Bar

Like many woodworkers, I have a limited amount of wall space in my shop. So I'm always looking for ways to increase the *usable* amount of space.

That's the idea behind this wall-mounted tool bar, see drawing. Besides holding a number of hand tools, the bar swings out from the wall. This provides easy access to additional tools *behind* the tool bar.

The tool bar consists of three parts: a *pivot arm* with a number of holes drilled in it to hold the tools, a pair of *support blocks* that "sandwich" the arm between them, and a *mounting*

plate that attaches to the wall.

Before assembling the tool bar, I cut an arc on the outside end of each support block and on both ends of the pivot arm. This removes the sharp corners, and it allows the pivot arm to swing freely without binding.

To create a pivot point, I used a bolt that passes through a hole in each support block and the pivot arm. Tightening a lock nut on the end of the bolt so it's just snug holds the arm in place yet still allows it to pivot.

Adolph Peschke
Des Moines, Iowa

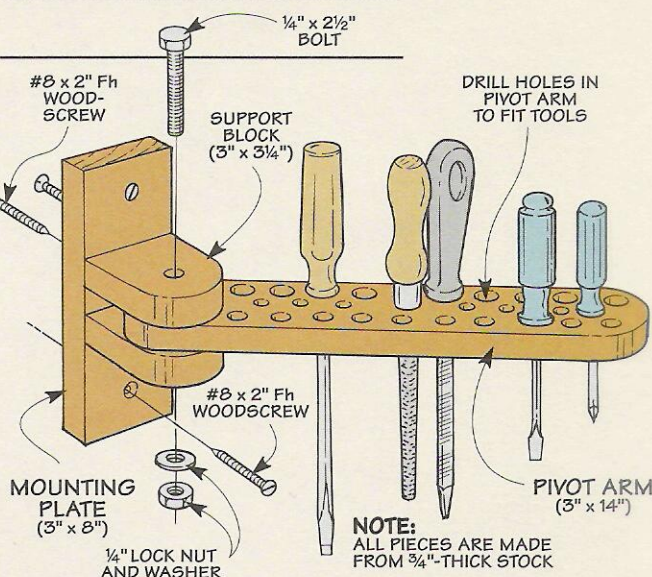

Cord Keeper

There's nothing more frustrating than having a power cord get jerked out of an electrical outlet in the middle of a job. Especially if I'm working on a project outside, and the power tool is plugged into a *long* extension cord.

To prevent that, I mount a "cord keeper" to the wall directly below the outlet, see drawing. It squeezes the

cord (or cords) between two wood blocks. So even if I tug on the cord, it stays plugged into the wall outlet.

The cords fit into two grooves that are routed in a *mounting block*. I used a core box bit in a table-mounted router to cut each groove. This creates a curved bottom that allows the cord to nestle into the block. Just be

sure the groove is shallow enough to allow the cord to stick up above the mounting block, see Top View. This will allow the wood *cover* of the cord keeper to exert pressure against it.

To produce this pressure, a long slot in the cover fits over a machine screw that's installed in the mounting block. Tightening a knob on the screw holds the cover in place.

Before screwing the cord keeper to the wall, I glued a short dowel into a hole in the mounting block to help align the cover. Also, gluing a couple of thin rubber strips to the cover will help improve its grip. (I cut scraps of rubber from an old bicycle inner tube.)

David Walls
Saint Albans, West Virginia

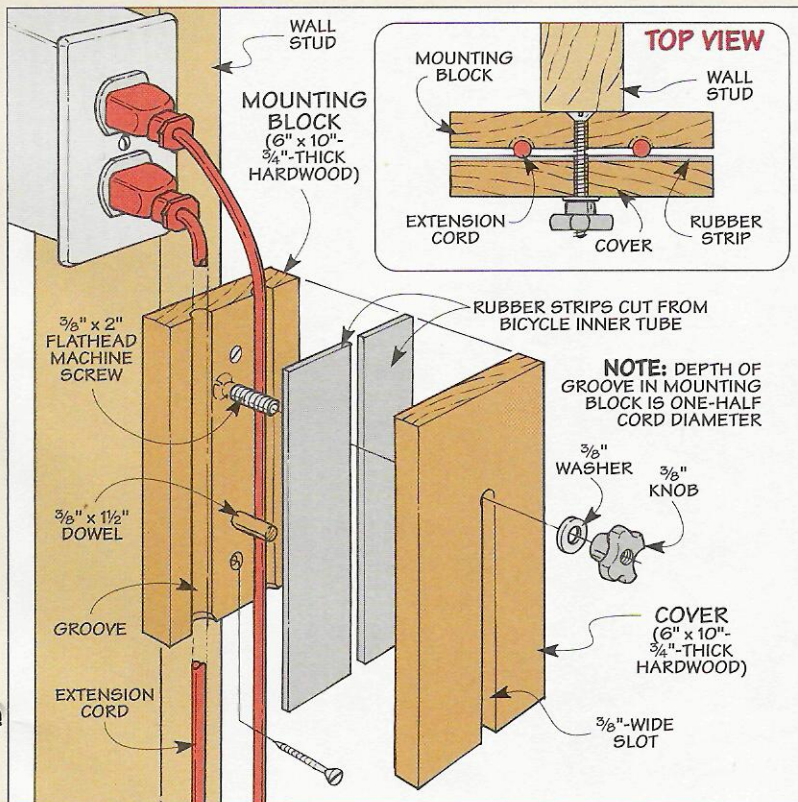

FREE Online Tips

If you'd like even more woodworking tips, the solution is simple. Just visit us at our website and sign up to receive a free tip via email every week.

www.shopnotes.com

Send in Your Shop Tips

If you have a unique shop tip, we'd like to consider featuring it in one or more of our print or electronic publications.

We'll pay up to \$200 for a tip we publish. Just write down the tip and mail it to *ShopNotes*, Attn.: Readers' Tips, 2200 Grand Ave., Des Moines, IA 50312. Or FAX it to 515-282-6741, or send us an e-mail at shopnotes@shopnotes.com. Please include your name, address and daytime phone number in case we have any questions.



Table Saw Workstation

Take one of the most versatile tools in your shop and make it even better. That's the idea behind this roll-around table saw station.

Im always looking for ways to make improvements to my table saw. That's why I'm so impressed with how this table saw workstation turned out

RIP FENCE. It started out simply enough. I installed a new T-square rip fence that was more accurate than my old fence and made it easy to rip large sheets of material, see photo A below. (For more information, see page 30.)

TABLE EXTENSION. Well one thing soon led to another. Now the fence had the capacity to rip wide pieces. But I needed a large extension table to support them. So I built an extension table that attaches to the side of the saw.

ROUTER TABLE. This table provided an ideal way to save some space in the shop. That's because it doubles as

a router table, see photo B. I even added an adjustable fence so I can use the router table *and* the table saw without having to "break down" either setup. (Plans for building the router table extension begin on page 8.)

CABINETS. The table saw and router table are supported by three cabinets that are "ganged" together as a single unit. (For a compact version, see page 7.) These cabinets provide storage, a built-in dust collection system, and a unique caster system that's definitely worth a close look. (Turn to page 16 for step-by-step plans.)

OUTFEED SUPPORT. Finally, to "catch" a long workpiece as it comes off the saw table, I added an outfeed support that folds for storage, see photo C and page 26.

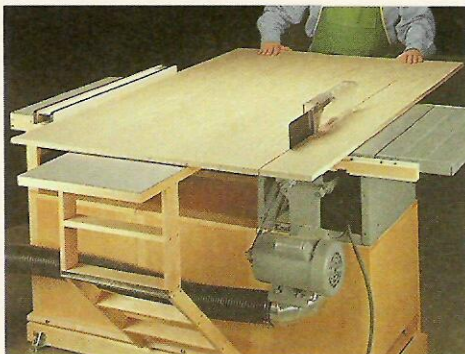

A. Rip Fence. Adding a precision rip fence and a large extension table makes it easy to rip sheet material up to 40" wide.

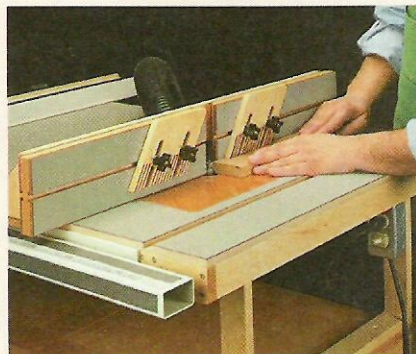

B. Router Table. To save space, the extension table doubles as a router table. There's even a removable fence.

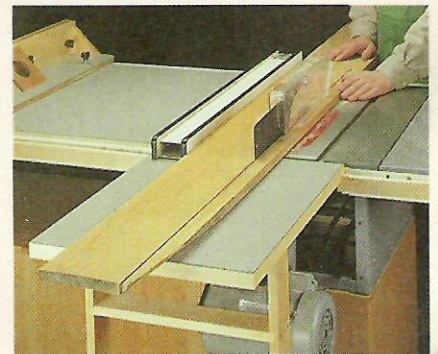

C. Outfeed Support. A simple outfeed table provides plenty of support when ripping a long workpiece.

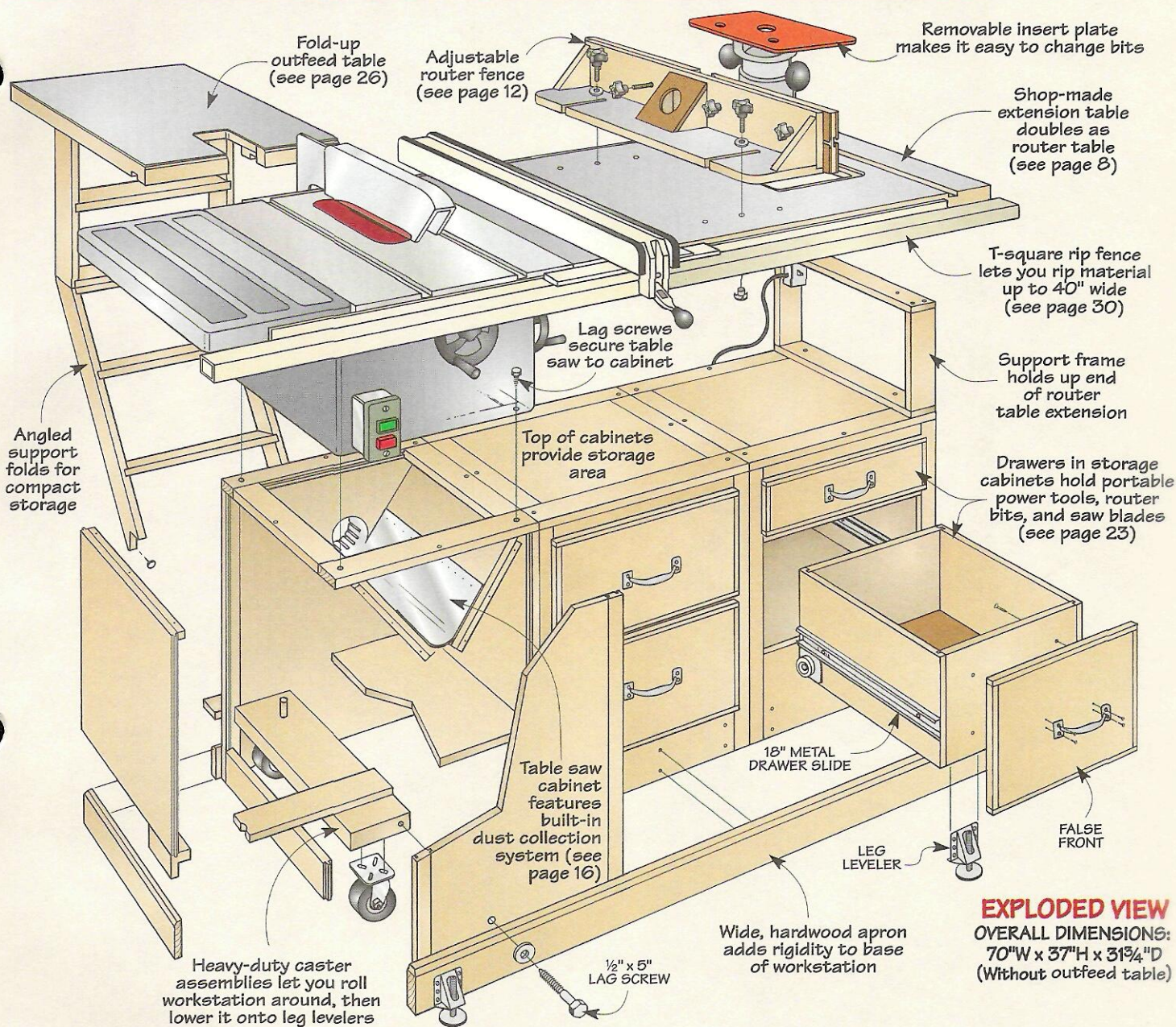

Compact Table Saw Station

If space is limited, one solution is to build this compact version of the table saw station.

RIP FENCE. Here again, the idea is to start with a T-square rip fence. But this fence has a smaller rip capacity (28"), so the guide rail is shorter.

ROUTER TABLE EXTENSION. This means that the extension table is smaller. Even so, there's still plenty of room to add a router table and fence.

TWO CABINETS. Since the overall size of the work-surface is smaller, you'll only need to build *two* cabinets instead of three. Just be sure to make the two *end* cabinets that are designed to house the caster assemblies.

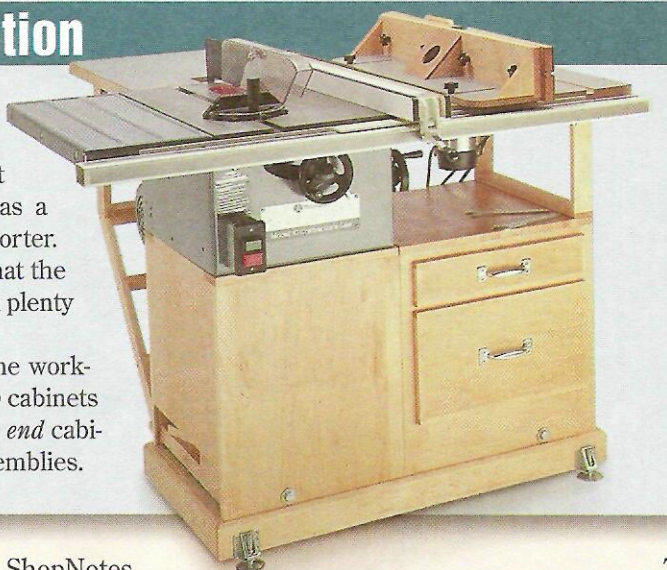



Router Table Extension

This space-saving router table replaces the metal extension wing on your table saw.

I don't ever recall meeting a woodworker who complained that his shop was *too* big. But whether it's large or small, it's important to get the most efficient use out of the space that is available.

That's what I like about this router table extension. It saves space by accomplishing *two* different jobs.

EXTENSION TABLE. First of all, it's a large *extension table* that provides extra support when ripping wide material on the table saw. That's just what I needed when I installed a new T-square style rip fence on my table saw. (For more information about this fence, refer to page 30.) Note: This table is a permanent replace-

ment for the metal wing on the saw.

ROUTER TABLE. To take advantage of the large worksurface, the extension table doubles as a *router table*. The router is mounted to an insert plate that lifts in and out of an opening in the table. This makes it easy to change bits. Plus, there's an adjustable fence that can be attached to the table (or removed) in seconds.

FRAME. To create a flat, solid worksurface, the router table is supported by a rigid frame that's made up of $\frac{3}{4}$ "-thick hardwood strips, see Fig. 2. (I used maple.)

The overall width of this frame is determined by the front to back dimension of the metal wing on the table saw. (In my case, this was 27".) As for length, I wanted it to be flush with the end of the guide rail for the rip fence. (I made a 39"-long frame.)

The frame starts out as two *long rails* (A) connected by five *stretchers* (B), see Fig. 2. Two of these stretchers work together with a pair of *short rails* (C) to support the insert plate that holds the router. To lay out the location of these four pieces, you'll need the insert plate.

INSERT PLATE. I bought my plate with pre-drilled holes. It's made of $\frac{3}{8}$ "-thick phenolic which is a hard,

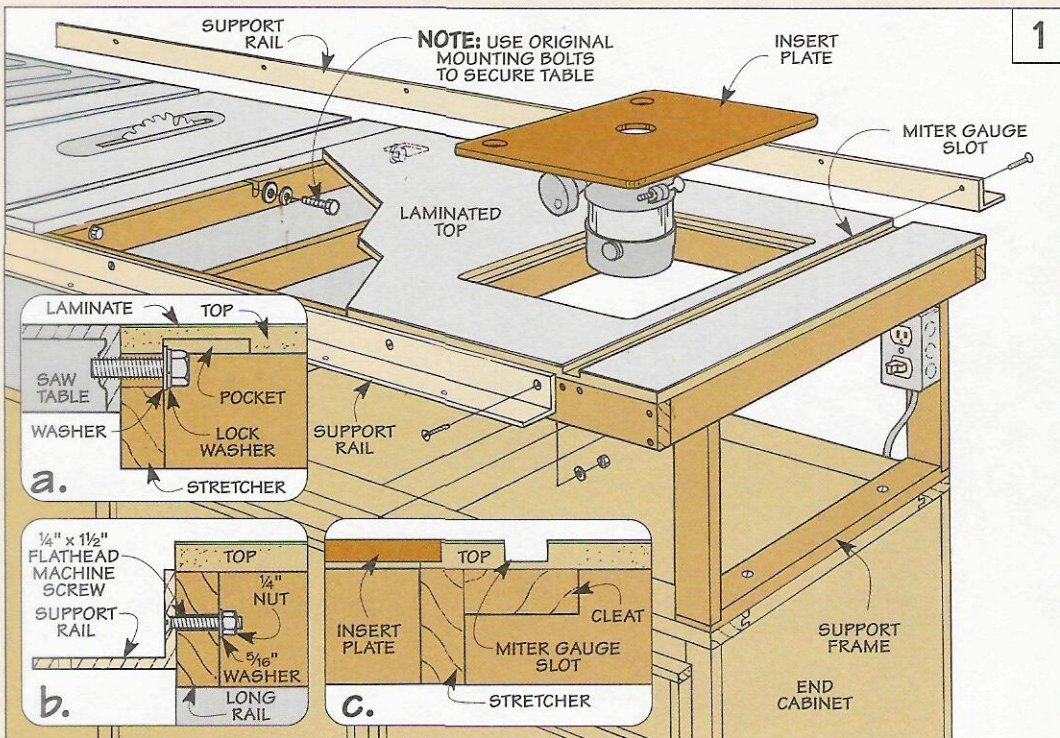

rigid plastic that won't sag.

LAYOUT. With the insert plate in hand, you can use it to establish the location of the two stretchers and a pair of dados that hold the short rails. The goal is to have the edges of the insert *centered* on the thickness of these frame pieces, see detail in Fig. 2.

ASSEMBLE FRAME. After cutting the dados, the frame is simply screwed together. I also screwed a *cleat* (D) flush with the top edge of the frame. Later, it helps "beef up" the area below the miter gauge slot in the table, see detail 'c' on page 8.

TOP. With the frame complete, the next step is to add the *top* (E) of the table, see Fig. 3. It's a large piece of 1/2" medium-density fiberboard (MDF) that's sized to fit flush with the outside of the frame.

For clearance when mounting the table, there are three shallow "pockets" underneath the top, see margin and Fig. 3. After using the existing mounting holes in the table saw to locate these pockets, a hand-held router and straight bit make quick work of cutting each recess.

You'll also need to cut three notches in the end of the frame that mounts to the table saw, see Fig. 3a. The notches allow the mounting bolts to pass through the frame. Note: I made them oversize to allow for adjustment.

After screwing the top to the frame, it's covered with plastic laminate to create a smooth, durable worksurface.

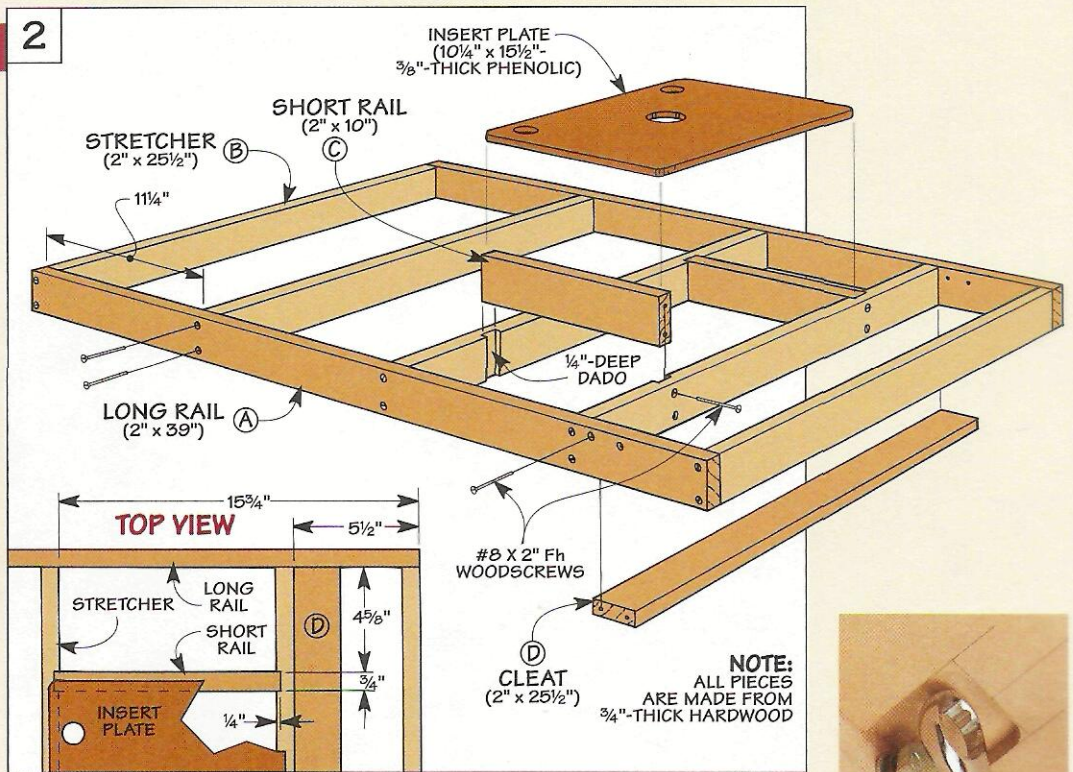

I used contact cement to glue on an oversize piece and then trimmed the edges with a router and flush trim bit.

MOUNT TABLE. Now you're ready to mount the table to the saw. The goal is to make the surface of the table *level* with the cast iron saw table. Start by bolting one end of the table *loosely* to the saw, see Figs. 1 and 1a. To hold up the other end, I used a pipe clamp as a temporary prop, see Fig. 4. Note: You may need to shim the bottom end of the clamp.

After using a straightedge to check that both surfaces are level, tighten the mounting bolts. Then

just attach the metal support rails of the fence to the table with machine screws and nuts, see Fig. 1b.

At this point, the table is pretty secure. But the outside end still needs to be supported. This can be something as simple as a pair of legs.

SUPPORT FRAME. Or if you build the cabinets shown on page 6, you can make a *support frame*, see Fig. 4. It consists of a pair of hardwood *uprights* (F) and two *mounting strips* (G) that are assembled with rabbet joints and screws. The support frame is simply screwed to the cabinet and table, see Figs. 4a and 4b.

▲ A shallow pocket underneath the table provides clearance for a wrench when installing the mounting bolts.

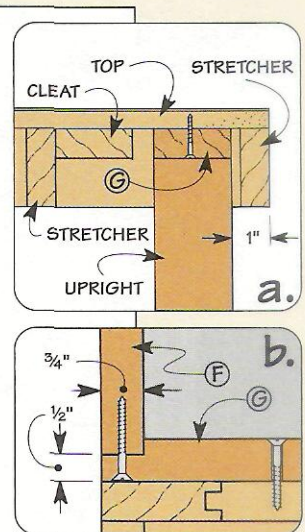
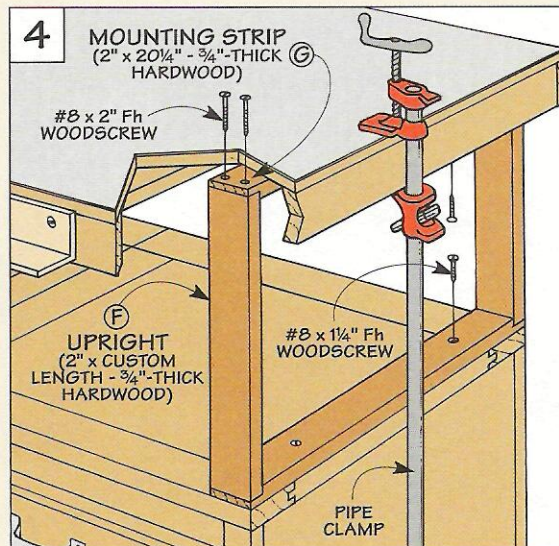
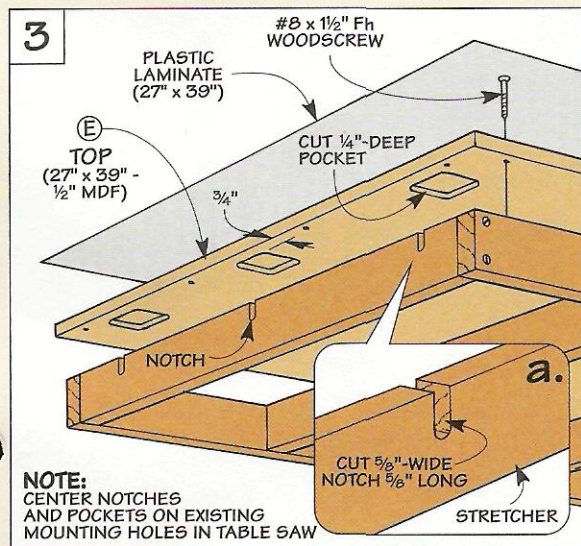

Insert Plate

After mounting the extension table to the saw, I added the insert plate that holds the router. It fits in a recessed opening in the table, see photo.

The only tricky part to adding an insert plate is cutting the recess. To hold the router securely, the insert plate has to fit the recess exactly.

ROUGH OPENING. To accomplish this, I started by cutting a *rough* opening, see Step 1. Then I trimmed the edges of the opening flush with the frame pieces below it.

ROUT LIP. Now you can rout the recessed lip for the insert plate to rest on. The secret to getting the outline of

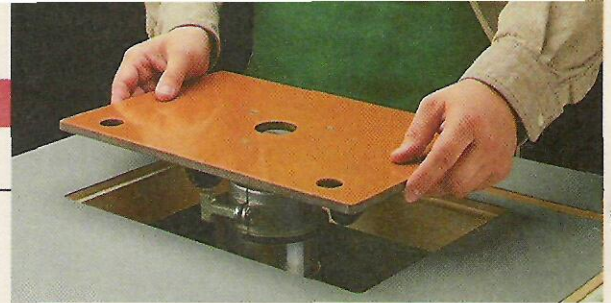

the lip to match the plate is to use the plate itself as a guide for positioning four *guide strips*, see Step 2. The strips guide the bearing on a pattern bit as you rout the lip.

Note: The cutting edges of the bit I used are 1" long. So to provide a surface for the bearing to ride against, I glued up two layers of material to make 1"-thick strips.

MOUNT ROUTER. After routing the lip, all that's left is to mount the router to the insert plate, see Step 3.

1 To create the opening in the table for the insert plate, start by drilling a hole just inside each corner of the framed opening below it, see detail 'a.' Then after removing the waste with a sabre saw, use a hand-held router and flush trim bit to trim the edges of the opening flush with the frame pieces, see detail 'b.'

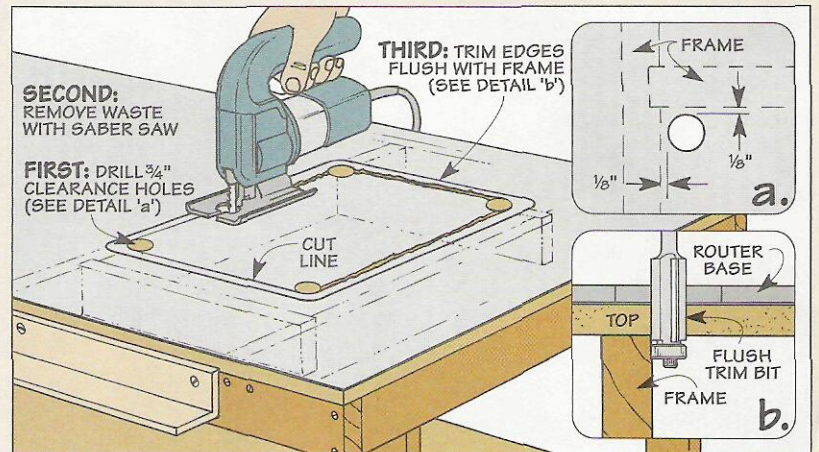

2 The next step is to use a 1/2" pattern bit in a router to cut a recessed lip in the extension table. To do this, center the insert plate over the opening and butt the guide strips against it, see detail 'a.' After adjusting the depth of cut (see margin), use the strips to guide the bearing on the bit as you rout in a clockwise direction, see detail 'b.'

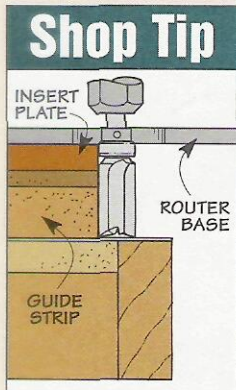

▲ To accurately set the depth of cut, place the insert plate on a guide strip. Then set the router on top of the plate and lower the bit until it barely touches the table.

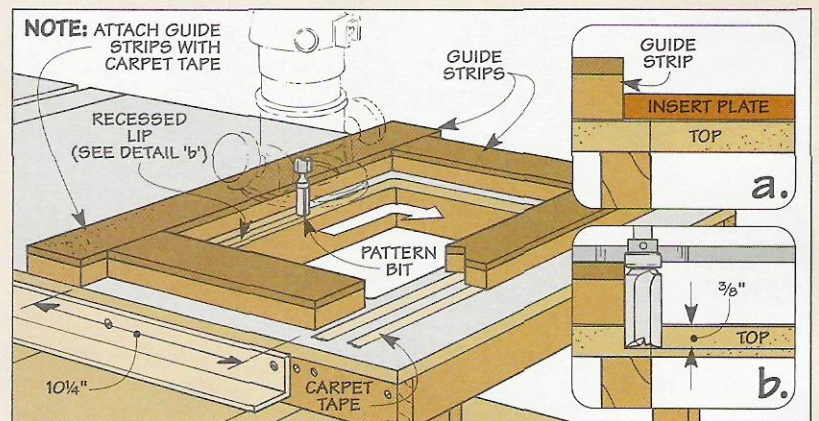

3 All that's left is to attach the router to the insert plate. This requires drilling holes for the machine screws that hold it in place. An easy way to locate the holes is to use the existing bearing on your router, see detail 'a.' Note: To keep the base from shifting, I carpet-taped it to the insert plate.

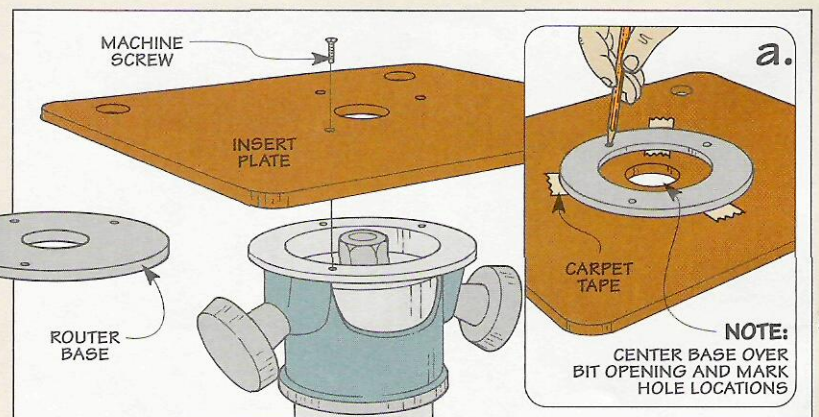

Miter Gauge Slot

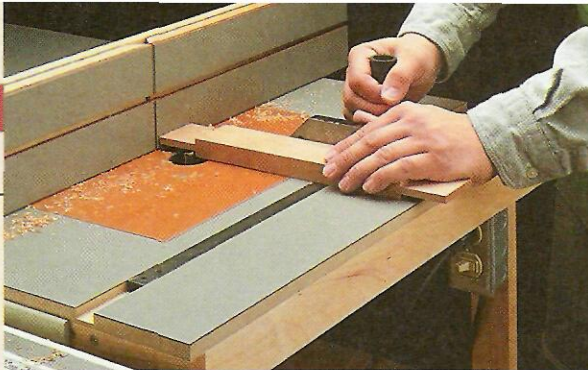

At this point, the router table is almost complete. All that's left is to rout a slot for the miter gauge.

To produce accurate results, the bar of the miter gauge should slide smoothly in the slot without binding. Yet it should be snug enough that there's no "play" when you wiggle the head of the miter gauge.

GUIDE STRIPS. To create a perfect fit, I used two long guide strips and a pattern bit mounted in the router. (These are the two long guide strips used when routing the lip.) Only this time, the miter gauge bar is sandwiched between the two strips, see Step 1.

ROUT SLOT. With the strips in place, you're ready to rout the slot. I set the depth of cut using a similar procedure as before. To do this, place the miter gauge bar on top of one guide strip, and the router on top of the bar. Then lower the bit to barely touch the table top. Now remove the miter gauge and rout the slot, see Step 2.

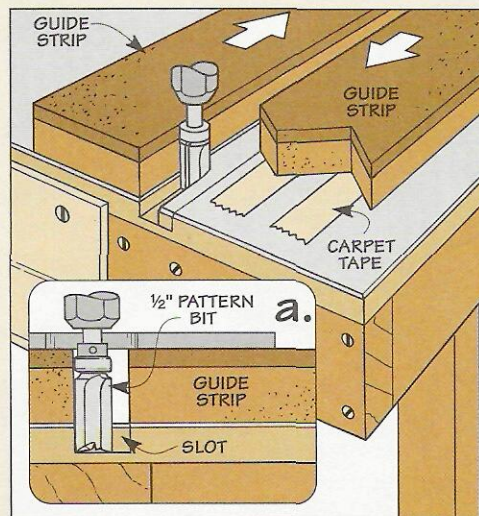
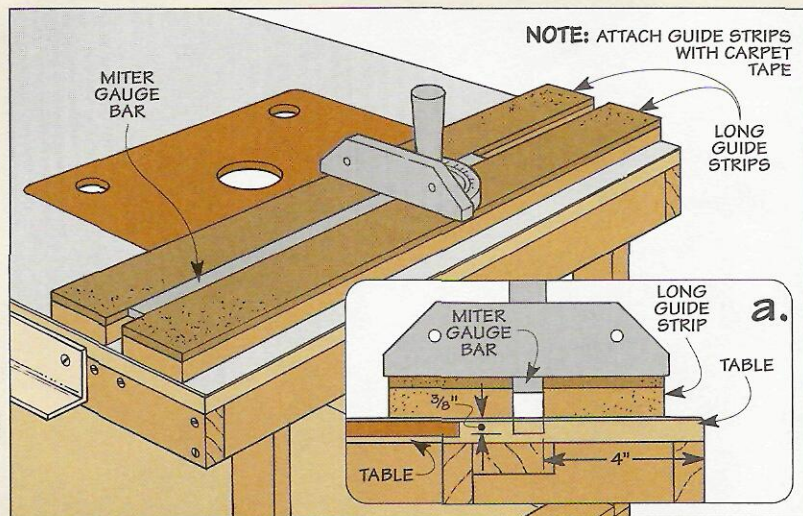

1 To establish the location of the miter gauge slot, carpet-tape one guide strip 4" from the end of the table, see detail 'a.' Then position the second guide strip snugly against the miter gauge bar.

2 Using a pattern bit in a router, cut the miter gauge slot by making two passes, one against each guide strip.

Electrical Hook-Up



When it comes to the electrical hook-up for the router table, there are a couple of options.

ROUTER SWITCH. The simplest approach is to plug the router into the nearest electrical outlet. Then turn it on and off using the switch on the router.

That works fine. But reaching under the table to locate the switch can get to be a nuisance.

FRAME-MOUNTED SWITCH. A handier solution is to mount a switch to the support frame under the table, see photo. To do this, run a short length of electrical cord (with a plug wired on one end) between a wall outlet and a switch/receptacle, see drawing. Then simply plug the power cord on the router into the receptacle and you're all set.

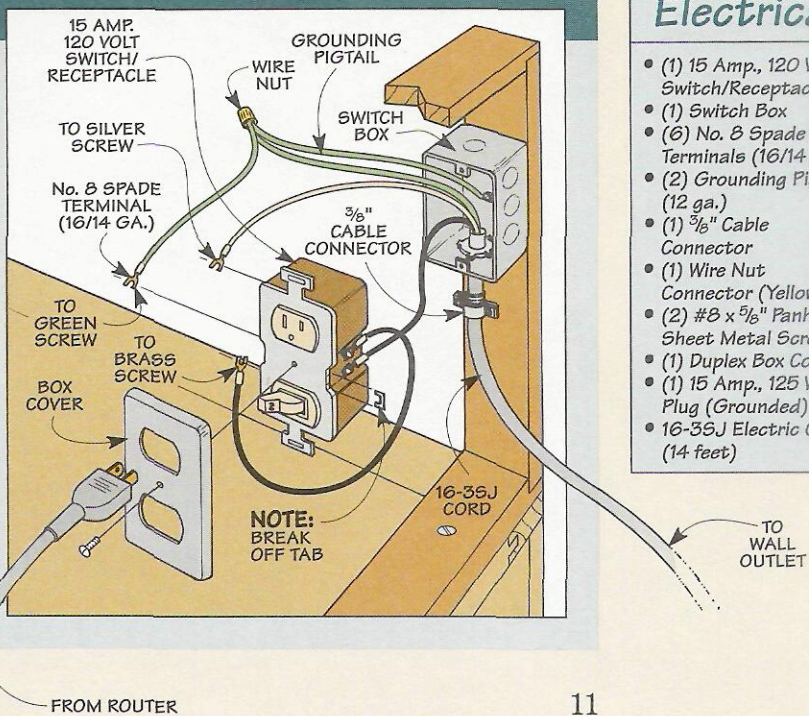

Electrical

- (1) 15 Amp., 120 Volt Switch/Receptacle
- (1) Switch Box
- (6) No. 8 Spade Terminals (16/14 ga.)
- (2) Grounding Pigtail (12 ga.)
- (1) 3/8" Cable Connector
- (1) Wire Nut Connector (Yellow)
- (2) #8 x 3/8" Panhead Sheet Metal Screws
- (1) Duplex Box Cover
- (1) 15 Amp., 125 Volt Plug (Grounded)
- 16-35J Electric Cord (14 feet)

Fence

As soon as the table extension was completed, I set about building the router fence. It consists of two main parts: an L-shaped *fence support* that attaches to the router table and a pair of *sliding faces*, see Fig. 5.

FENCE SUPPORT

The fence support serves as a mounting surface for the sliding faces. Plus it allows you to adjust the fence in relation to the bit.

BASE. To create a stable platform for the fence, I began by making a wide base (*H*) from 1/2" MDF, see Fig. 6. It's covered on both sides with plastic laminate. Besides creating a slick surface that allows the fence to slide smoothly, this ensures that the base stays flat.

The next step is to rabbet the front edge of the base to accept a *fence back* (added later). I also cut a large notch in the same edge. It prevents the base from getting chewed up by the bit. Also, the notch allows the

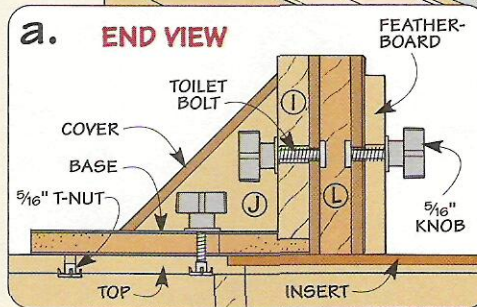
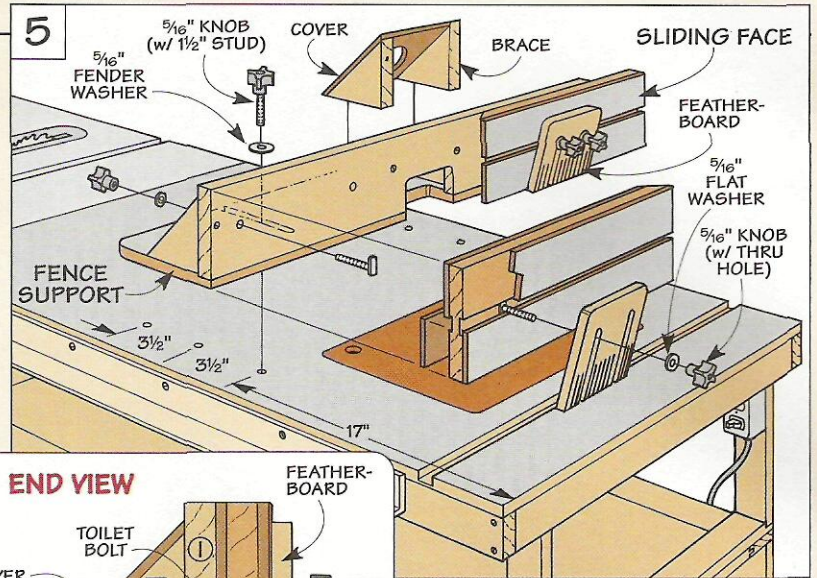

▲ With a tall fence and two sliding faces, this router table fence makes it easy to produce accurate results.

slots fit over knobs that thread into T-nuts in the table, see Figs. 5 and 5a.

To provide a range of adjustment, there are three T-nuts on each side of the table. An easy way to establish the location of these T-nuts is to center the base on the width of the table. Then mark the centerline of each slot and drill the holes 3 1/2" apart.

FENCE BACK. After installing the T-nuts, I added a *fence back* (*I*), see Fig. 6. It's a wide (tall) piece of hardwood that supports the sliding faces. Here again, there's a notch in the bottom edge for bit clearance and dust collection. Also, to provide a way to attach the sliding faces, I installed four toilet bolts. (The bolts fit into T-slots in back of the sliding faces.)

BRACES. To hold the fence back (*I*) square to the base, I added four triangular *braces* (*J*). These are just pieces of 3/4"-thick hardwood that are held in place with screws.

DUST HOOK-UP. Next, to collect dust and chips, I added a hardboard *cover* (*K*). After cutting a hole in the cover for the vacuum hose and beveling the edges to fit against the fence, the cover is simply screwed to the two braces.

SLIDING FACES

At this point, you can turn your attention to the two *sliding faces*. They provide a way to adjust the size of the opening around the bit. By "closing"

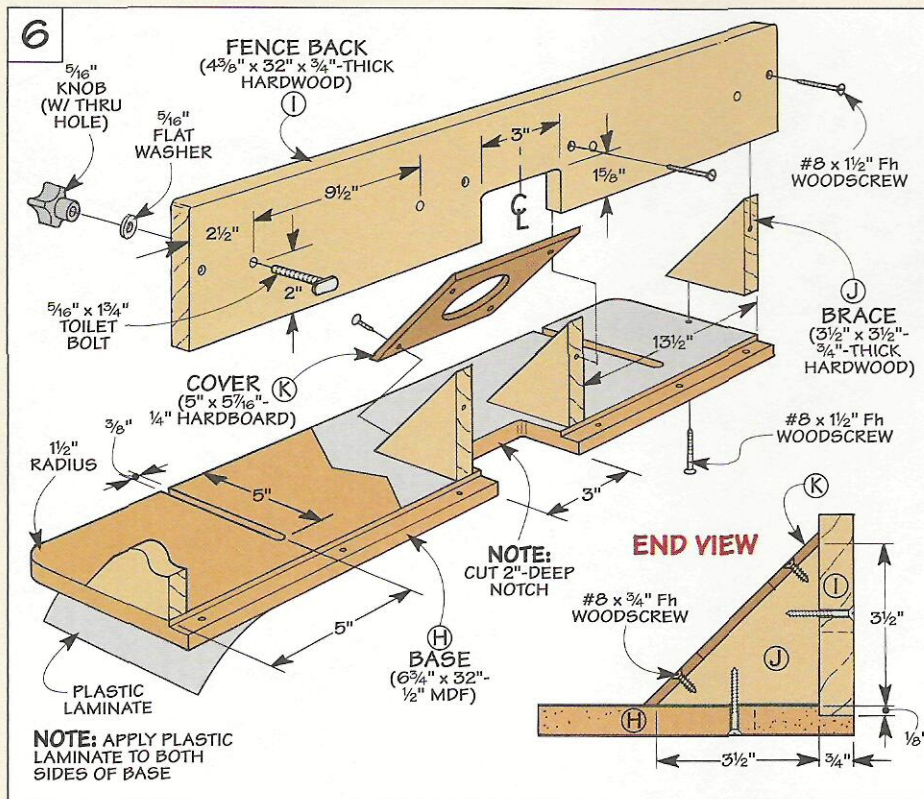

NOTE: APPLY PLASTIC LAMINATE TO BOTH SIDES OF BASE

the sliding faces around the bit, it prevents the end of a workpiece from accidentally tipping into the opening.

LAYER CAKE. The sliding faces start out as a single blank that's built up like a layer cake, see Fig. 7. This makes it easy to form T-shaped slots on both sides of the sliding faces. As I mentioned, the T-slots in back fit over toilet bolts in the fence back. The front slots hold toilet bolts that are used to attach two featherboards.

I started with a 3/4"-thick hardwood core piece (L) and cut a wide, shallow groove in each side, see Figs. 7 and 7a. The core piece is sandwiched between two 1/4" hardboard skins (M). Also, to create a durable surface on the front of the fence, I glued on a layer of plastic laminate.

Once the layers are all glued on, you can complete the T-slot by cutting a narrow groove in each side, see Fig. 7b. Now just separate the blank into two equal-sized parts to form the sliding faces. To provide clearance for large bits, I also cut a bevel on the inside end of each face, see Fig. 7c.

FEATHERBOARDS

To hold a workpiece flat against the table, I added two featherboards.

Each featherboard starts off as a 1/2"-thick blank with both ends mitered at 30°, see Figs. 8 and 8c. To apply downward pressure against a

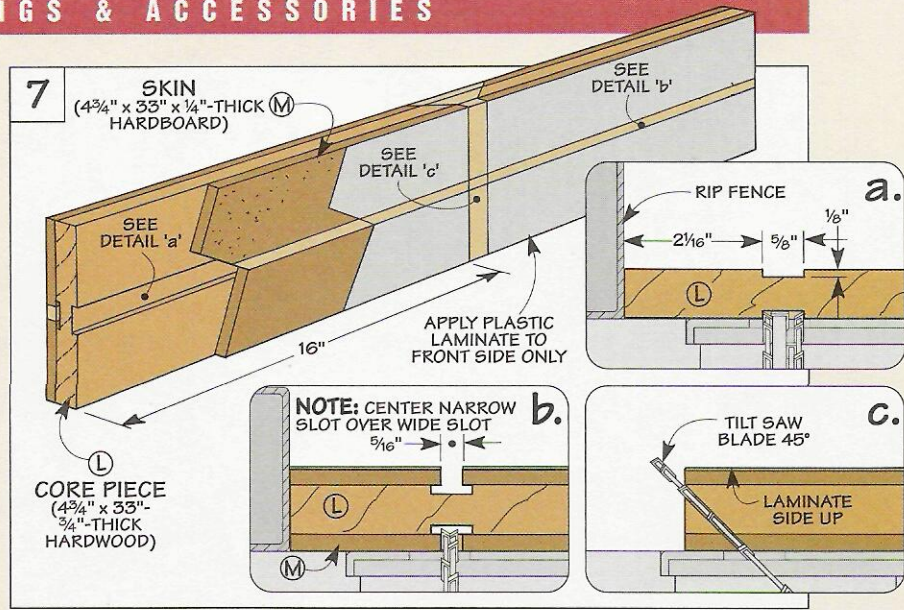

workpiece, there are a number of wood "fingers" on one end of the featherboard. The trick is to space the fingers evenly apart.

INDEX PIN. To do this, I used a simple index pin and a wood fence attached to the miter gauge on the table saw. The pin is just a scrap that's the same thickness as the desired spacing of the fingers, see Fig. 8a. (In my case, this was 1/8".)

To install the pin, start by tilting the saw blade to 30° and cutting an angled kerf in the miter gauge fence. After gluing the pin in the kerf, you'll need to reposition the fence on the miter gauge. The idea is to screw it to the miter gauge so the pin is 1/8" from the blade (the width of a finger).

Now you're ready to make the fingers. Start by butting the edge of the blank against the index pin. Then clamp it to the fence and make a single pass.

Once the first kerf is cut, slip it over the index pin, see Fig. 8b. Then reclamp the blank against the fence and make another pass. To complete all the fingers, just repeat the process. Note: If the last finger is wider than the others, you may need to trim the waste from the edge.

ADJUSTMENT SLOTS. All that's left to complete the featherboards is to cut two adjustment slots. They allow you to raise or lower the featherboards to apply pressure against pieces of different thicknesses.

Hardware

- (32) #8 x 2" Fh Woodscrews
- (32) #8 x 1 1/2" Fh Woodscrews
- (4) #8 x 1/4" Fh Woodscrews
- (4) #8 x 3/4" Fh Woodscrews
- (6) 5/16" T-Nuts
- (8) 5/16" x 1 3/4" Toilet Bolts
- (8) 5/16" Star Knobs (w/ thru hole)
- (2) 5/16" Star Knobs (w/ 1/2" threaded stud)
- (8) 5/16" Flat Washers
- (2) 5/16" x 1 1/2" Fender Washers
- (1) 10 1/4" x 15 1/2" Insert Plate

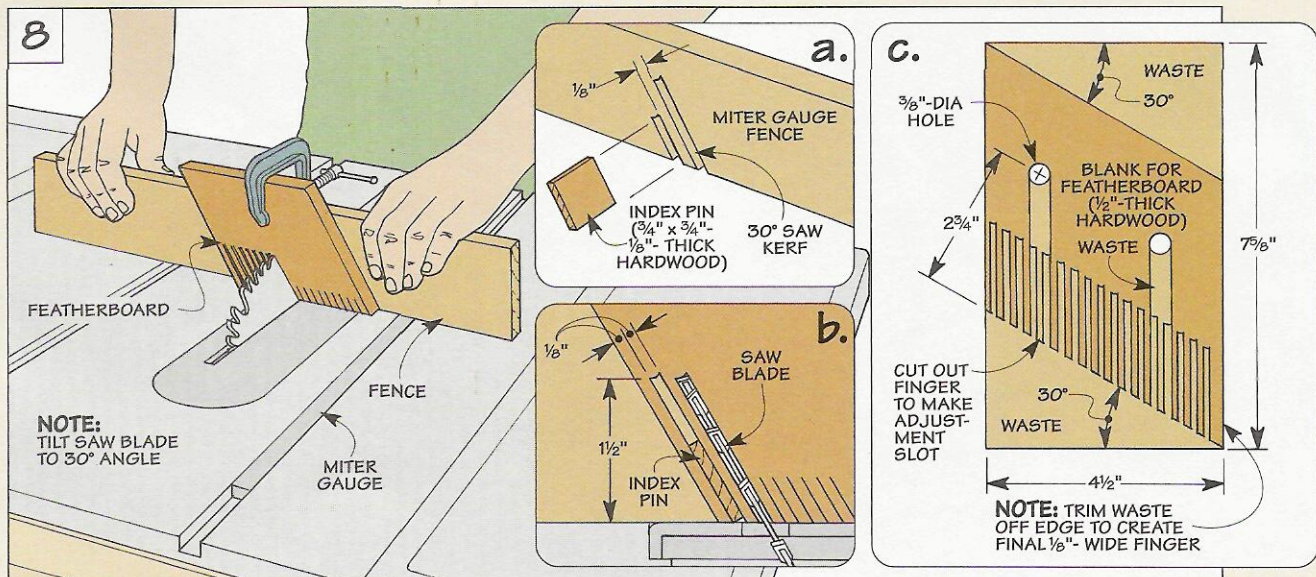

Router Table Tips

Routing Small Pieces

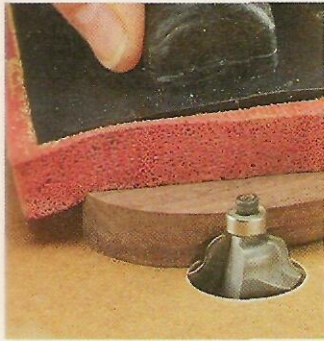

■ When routing small pieces on a router table, how do you keep them from tipping into the hole in the insert plate? One solution is to add an auxiliary top made of 1/8" hardboard, see drawing. To provide clearance for the router bit, you'll need to drill a

hole in the top. Note: Drill the hole slightly larger than the bit.

All it takes to attach the top to the router table is a few strips of carpet tape. With the top in place, raise the bit through the hole to the desired

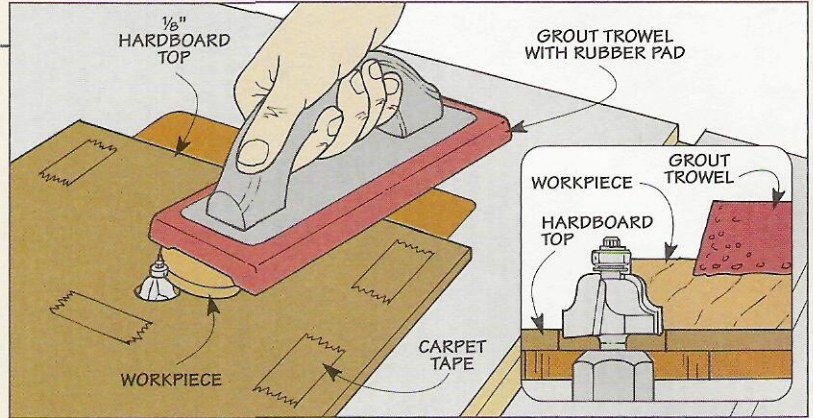

height and you're ready to start routing. The only problem is how to safely hold a small workpiece.

The best way I found to do this is to hold them with a rubber-bottom

grout trowel, see photo. This way, I can control the cut without getting my fingers close to the bit. Note: Grout trowels are available at most hardware stores and home centers.

Using a Starting Pin

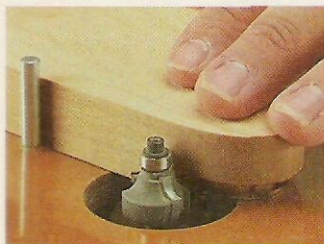

■ If you're using a piloted bit to rout an irregular-shaped workpiece, the beginning of a cut can be a bit tricky. That's because the bit has a tendency to grab the workpiece.

To reduce the chance of that happening, I use a starting pin, see photo. This is just a cutoff bolt that threads into a hole in the insert plate, see drawing.

It's easy to use a starting pin. Simply pivot the workpiece against the pin as you feed it into the bit. The pin provides the leverage needed to make a controlled cut.

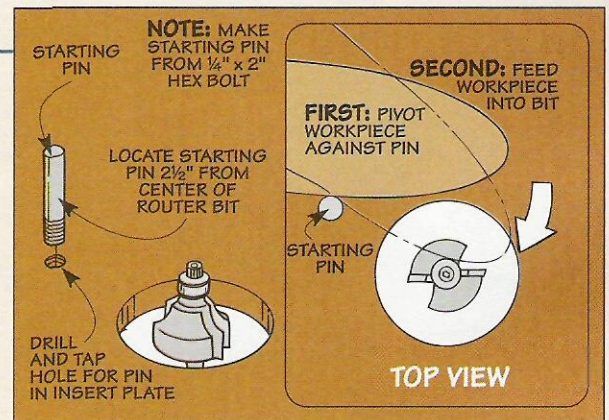

Routing End Grain

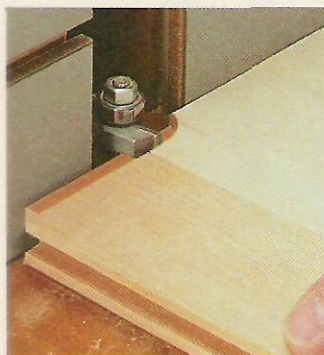

■ There are many times when I want to rout the end of a narrow workpiece. The problem is the wood fibers on the back edge splinter as the bit exits the cut. Fortunately, all it takes to produce a crisp, clean cut is a simple backer block, see photo.

This is nothing more than a squared-up scrap block that rides against the fence as you push the workpiece past the bit, see drawing. To prevent chipout, just be sure the block is at least as thick as the workpiece.

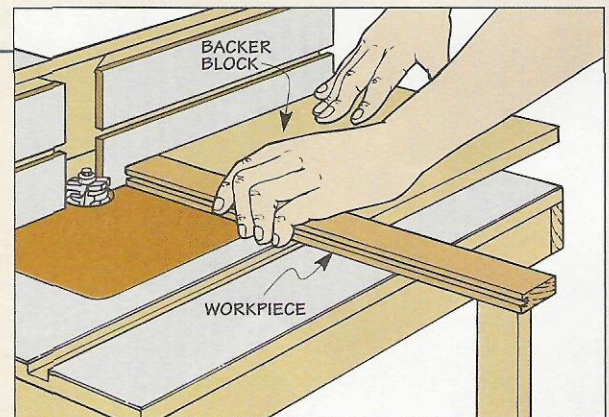

Router Table Jointer

■ With just a strip of plastic laminate, you can convert a router table into an edge jointer, see photo at right. In fact, a “router-jointer” puts a surprisingly straight edge on a workpiece.

To turn a router table into an edge jointer, simply attach the laminate to the *left* (outfeed) side of the router

fence with carpet tape, see drawing. The idea is to align one end of the laminate with the opening in the fence, see detail. I also file a bevel on this end to reduce the chance of a workpiece catching on the laminate.

STRAIGHT BIT. All it takes to joint an edge is an ordinary straight

bit. I prefer using a bit with a $\frac{1}{2}$ " shank. The thick shank helps reduce vibration and chatter. Note: One limitation with this setup is that the thickness of the workpiece can't exceed the length of the cutting edge on the bit.

ALIGN FENCE. After mounting the bit in the router, the next step is to align the fence. The goal is to position the fence so the surface of the laminate is flush with the *outermost* cutting edge of the bit, see detail. This will produce a cut that equals the thickness of the laminate.

JOINT EDGE. After locking the fence, you can turn the router on and joint the edge of the workpiece. To do this, hold the workpiece firmly against the fence as you slide it past the bit, making as many passes as needed to produce a straight edge.

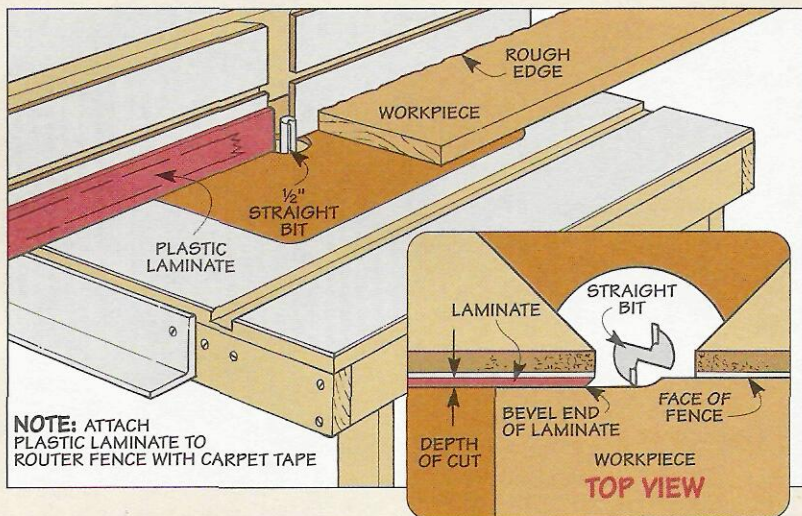
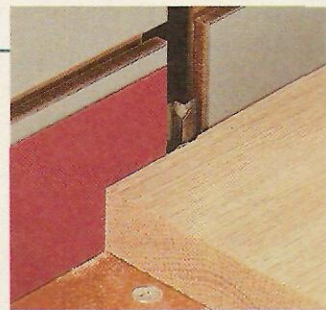

NOTE: ATTACH PLASTIC LAMINATE TO ROUTER FENCE WITH CARPET TAPE

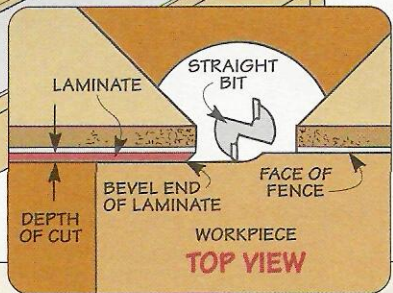

Using Templates

■ Few things in woodworking are as frustrating as trying to make several irregular-shaped pieces exactly the same. The solution is to use a template and a flush trim bit. The bearing on the bit rides against the edge of the template and trims the workpiece to the exact shape of the template, see photo.

TEMPLATE. I use $\frac{1}{4}$ " hardboard to make the template. It's an inexpen-

sive, hard material that doesn't have any voids or knots, and you can shape it easily.

To make a template, start by laying out the shape you want on the hardboard. Or you can cut a full-size pattern out of paper and glue it to the hardboard. Then cut out the shape slightly oversize, and file (or sand) carefully up to the line.

Keep in mind that any notches or

gouges on the edge of the template will show up later on the finished pieces, so it's important to take the time to work the edges smooth.

After the template is made, attach it to the workpiece with carpet tape. Then use a band saw (or sabre saw) to cut around the template so the workpiece is about $\frac{1}{16}$ " larger than the template.

Once the workpiece is cut to rough size, you can rout the last $\frac{1}{16}$ " of material with a flush trim bit on the router table, see drawing. With the template still taped to the top of the workpiece, raise the router bit up until the bearing rides on the edge of the template, see detail. Then rout in a clockwise direction around the bit.

One thing to keep in mind is the cutting edge of the bit. It should be slightly *longer* than the thickness of the workpiece. That way, the bit trims the entire thickness of the piece. 

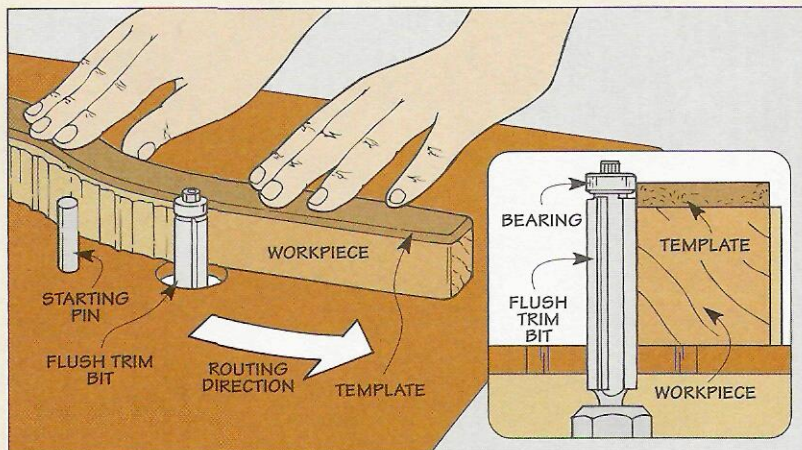
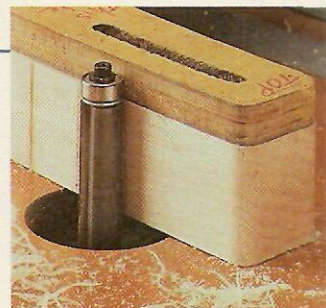

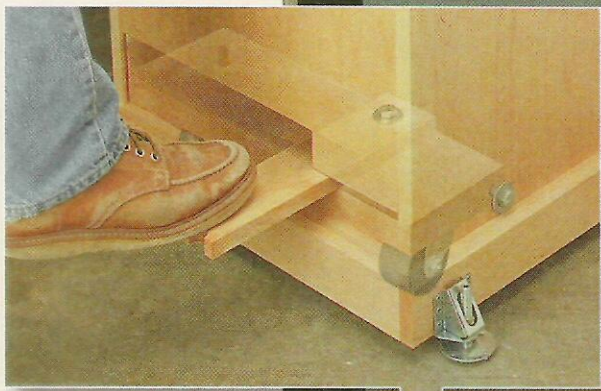

▲ To engage a heavy-duty caster assembly in each end of the cabinets, just step down on a wood lever and slide it to the side.



Table Saw Cabinets

These roll-around cabinets add weight and stability to a table saw. Plus they offer storage and a built-in dust collection system.

At a glance, this table saw workstation looks like it's supported by a single, long cabinet. But it's not. Actually, there are *three* separate cabinets. Each one is built as an individual unit. Then the cabinets are set side by side like giant building blocks and fastened together.

What's the purpose of building the cabinets this way? One reason is it simplifies the construction. Plus it makes it easy to customize the work-

station if you only want to build two cabinets. (See page 7 for more on this.)

CASTERS. No matter which combination you choose, there's a unique caster system housed in the lower part of the end cabinets, see inset photo above. It lets you raise the cabinets onto the casters to roll the workstation around. Once it's in the desired location, you can lower it off the casters and onto a set of levers to create a stable workstation.

STORAGE. The cabinets also provide plenty of storage. A set of three deep drawers hold portable power tools. And a shallow drawer keeps saw blades and router bits handy.

DUST COLLECTION. One thing you *don't* see is what's inside the cabinet that holds the table saw — a built-in dust collection system. It's designed to be hooked up to a dust collector. But don't worry if you don't have a dust collector. There's a simple modification shown on page 17.

TABLE SAW CABINET

I started by building the end cabinet that holds the table saw. Basically, it's a plywood box with solid wood corners and an open wood frame for a top, see drawing at left.

SIZE. The first step is to determine the size of the cabinet. It's designed to fit flush with the metal housing on the table saw. So just measure the width and depth of the housing and size the cabinet accordingly.

Another thing to consider is the *height* of the cabinet. The height of the cabinet shown here is 24½" (with levelers). This puts the *working height* of my saw at 37". Note: You may want to modify the height of the cabinet to provide a more comfortable working height.

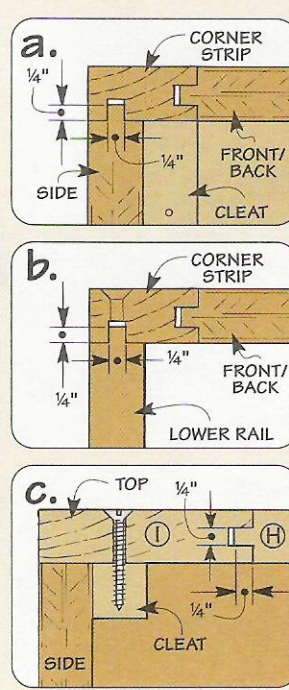
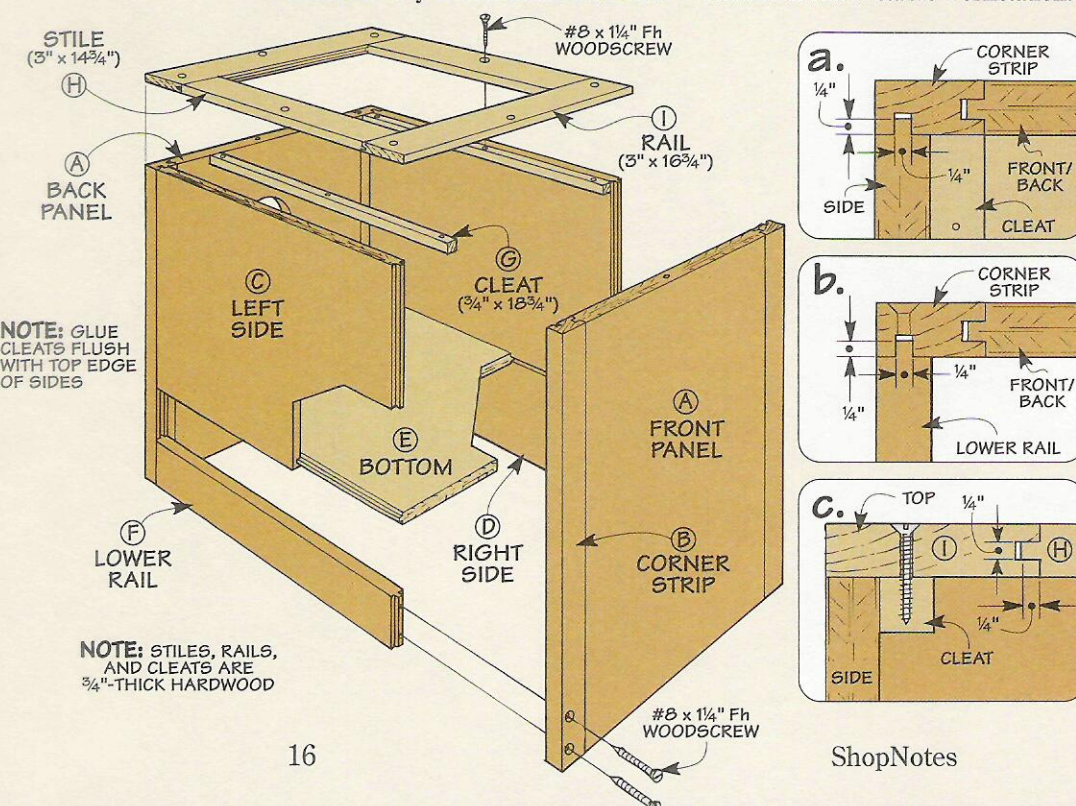

FEATURE PROJECT

FRONT/BACK. Once the size is established, the first step is to make the front and back of the cabinet. As you can see in Fig. 1, they're both made up of a plywood *front/back panel* (A) with a hardwood *corner strip* (B) applied to each vertical edge.

TONGUE & GROOVE. These pieces are assembled with simple tongue and groove joints. This requires cutting a tongue on two edges of the front and back panels, see detail in Fig. 1. To accept these tongues, you'll also need to cut a *centered groove* in the edge of each corner strip.

There's also an *off-center groove* in the *face* of the strip for a tongue that's cut later on the sides. But it's best to cut this groove *after* the tongue is made on the sides. Note: We've included an article explaining how to cut tongue and groove joints beginning on page 24.

DUST PORT. Before working on the sides, I cut a large hole in the back, see Fig. 1. This hole is sized to accept a 4"-dia. metal pipe that's part of the dust collection system.

SIDES. Now you're ready to add the two sides. One thing to note here is the *left side* (C) is *shorter* than the *right side* (D), see Fig. 2. When the cabinet is assembled later, the short

side helps to form an opening at the bottom of the cabinet that provides access to the caster system.

Like the front and back panels, there's a tongue on the two vertical edges of each side. Once the tongue is made, you can cut the off-center groove in the corner strip to fit it.

BOTTOM. The next step is to add a plywood *bottom* (E), see Fig. 2. Here again, there's a tongue on two edges of this piece, see Figs. 2a and 2b. Only this time, they fit into a dado cut in each side piece.

LOWER RAIL. Before assembling the cabinet, I added a hardwood *lower rail* (F), see drawing on page 16. Besides adding rigidity to the cabinet, it helps create the opening for the casters. The rail fits into the grooves in the corner strips. This requires cutting a short (stub) tenon on both ends of the rail, see detail 'b.'

ASSEMBLY. Now it's just a matter of gluing and clamping the cabinet together. To strengthen the lower rail, I installed two screws in each end. Also, gluing a pair of hardwood *cleats* (G) to the sides of the cabinet will provide a way to secure the top.

TOP. The top is nothing more than an open wood frame that allows simple dust and chips to fall inside the cab-

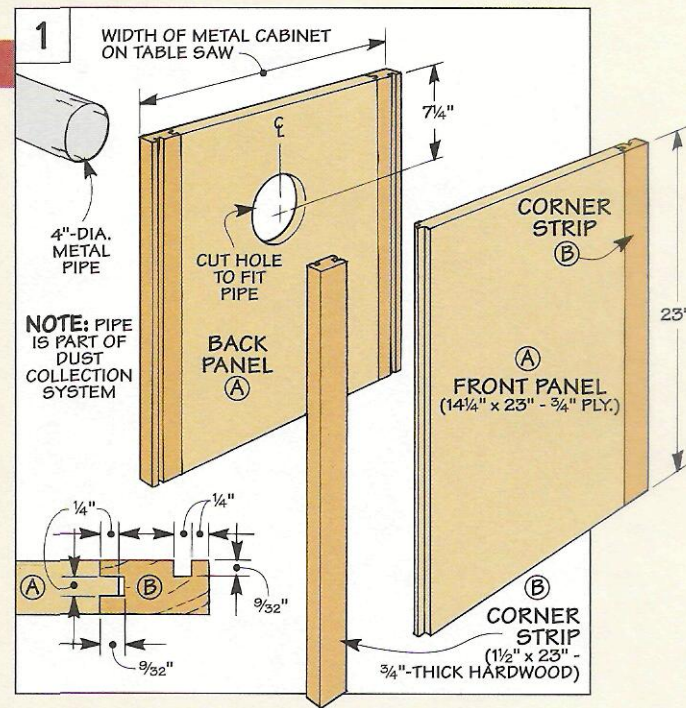

inet. It consists of 3/4"-thick hardwood *stiles* (H) and *rails* (I) that are sized so the frame fits flush with the outside of the cabinet.

The frame pieces are assembled with stub tenon and groove joints. This requires cutting a groove in the inside edge of the rails only and a short (stub) tenon on both ends of each stile, see detail 'c' on page 16.

After gluing up the top, don't attach it just yet. This will make it easier to install the dust collection system added next.

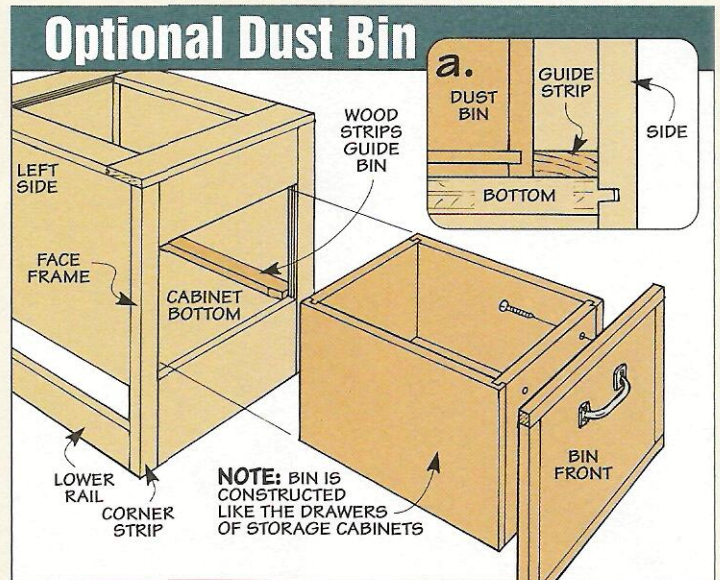
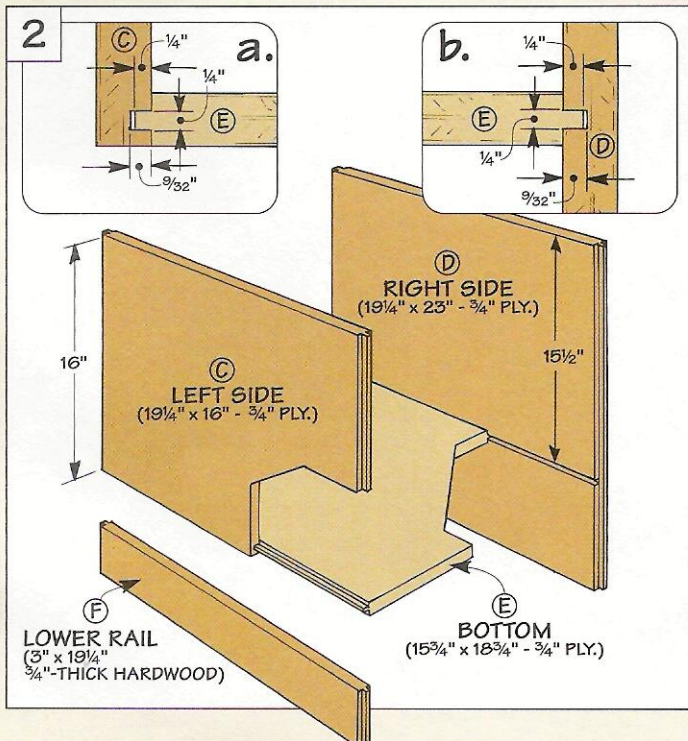

▲ You don't need a dust collection system to pick up chips and dust. A bin that slides into an opening in the cabinet provides a simple alternative. Just make a face frame for the front of the cabinet and glue wood strips to the bottom to guide the bin in and out.

Dust Collection System

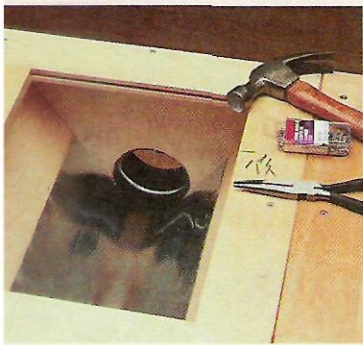

With the outside of the cabinet complete, you can turn your attention to the dust collection system *inside*.

It houses a large, V-shaped trough that's covered with a thin sheet of metal, see photo at left and Fig. 3. This creates a smooth, angled surface that directs chips and dust down to the bottom

▲ An angled trough covered with a thin sheet of metal directs chips out the opening in back of the cabinet and into a dust collector.

of the trough and into a dust collector. **BAFFLES.** The angled sides of the trough are formed by two plywood baffles (J), see Fig. 4. Each baffle is held in place by a pair of hardwood support strips (K) attached to the front and back of the cabinet.

The important thing is the *location* of the support strips. The goal is to position the strips so the top of each baffle is flush with the edge of the hole in back of the cabinet, see Fig. 4a. This will create a smooth transition from the baffles to the hole when the metal covering is added.

Once you've established the location of the support strips, they're fastened to the front and back of the cabinet with glue and screws. Then

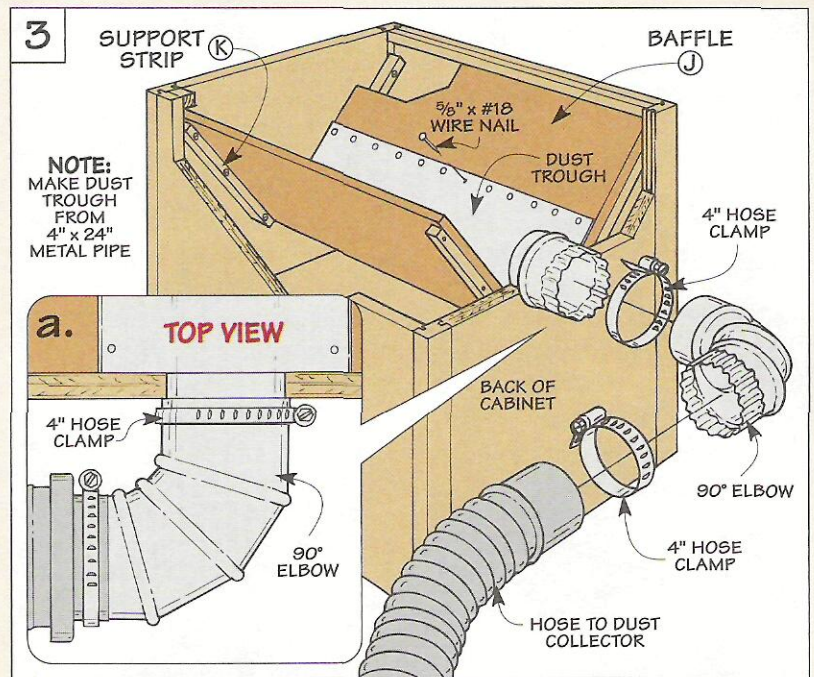

simply glue and screw the baffles to the support strips, see Fig. 4a.

METAL COVERING. At this point, there's still an opening at the bottom of the trough between the baffles. That's where the metal covering comes in. It bridges the opening and forms a smooth, U-shaped surface

across the lower part of the baffles.

METAL PIPE. This metal covering is actually just a piece of 4"-dia. metal pipe. (I picked up a 24"-long piece of snap-together pipe at a home center.)

This type of pipe is crimped at one end. To create a hook-up for the dust collector, a short length of the pipe near the crimped end forms a "neck" that sticks out the back of the cabinet. The remaining part of the pipe is spread apart like a baked potato to create two flaps that will lie flat on the baffles, see photo on page 19.

TRIM PIPE. But first, you may need to trim the pipe to length. The final length of the pipe depends on the depth of the cabinet. The best way I found to determine this length is to test fit the pipe in the cabinet.

It's tempting to snap the pipe together to do this. There's only one problem. When it's time to cut the flaps, it would be a pain to pull the pipe apart. The solution is to roll the pipe into a cylinder and *tape* it together.

Now slide the pipe through the hole until it contacts the *front* of the cabinet, see Step 1 on next page. With the pipe in this position, measure the distance from the back of the cabinet to the "rib" near the

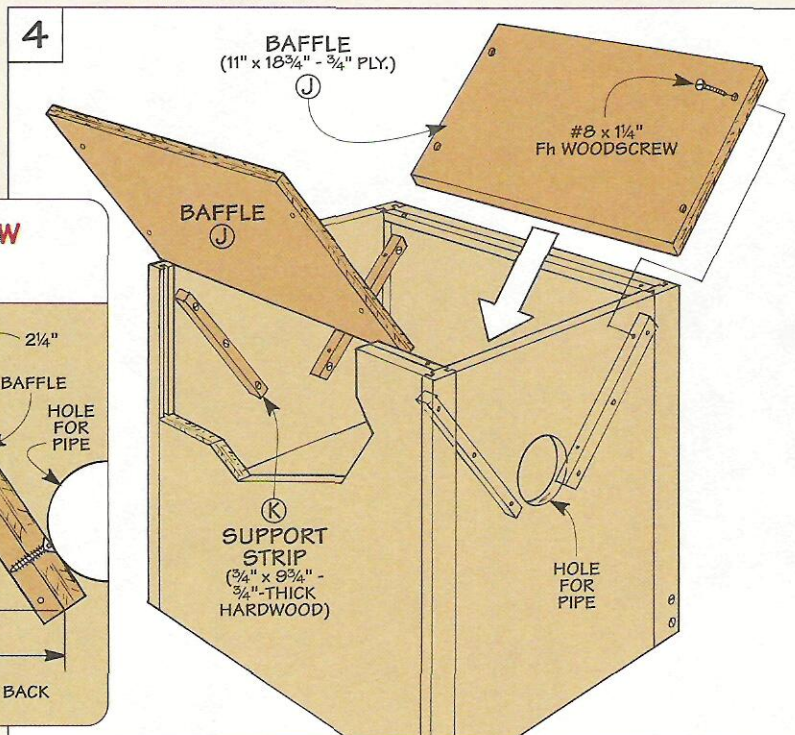

crimped end. This is the amount you want to remove. Just be sure to remove the pipe and trim the end that's *not* crimped.

LAY OUT FLAPS. The next step is to lay out the cut lines on the pipe for the two flaps. Start by slipping the pipe all the way back into the cabinet (with the seam facing up). Then draw a line about a third of the way around both sides of the pipe, see Step 2.

CUT FLAPS. After removing the pipe again, a pair of tin snips makes quick work of cutting the flaps, see Step 3. Be careful though, the edges are sharp. Once the flaps are cut, it's a good idea to trim off the locking

tabs along the long edges of the pipe. This will create a smooth transition from the metal covering to the baffles and will prevent slivers of wood and dust from catching on the edges.

INSTALL COVERING. Now that the pipe is cut, you can snap the locking tabs on the crimped end together and install the metal covering. To do this, slip the crimped end of the pipe into the hole from the *inside* of the cabinet and spread out the flaps on the baffles.

The flaps will have a tendency to curl up, so getting them to lie flat is a challenge. A little help from a friend will save a lot of frustration when it comes to pressing the flaps down

flat on the baffles. To avoid any ripples in the edge, I nailed the flaps about 1" apart, working from one end to the other.

After nailing the second flap in place, I screwed the neck of the pipe to the cabinet. Also, applying a bead of silicone wherever the metal covering meets the cabinet will prevent dust from escaping.

DUST HOOK-UP. All that's left is to install the fittings used to hook up the hose from the dust collector. I tightened a 90° elbow onto the pipe with a hose clamp, see Figs. 3 and 3a. This way, the hose will run along the back of the table saw cabinets.

BEFORE

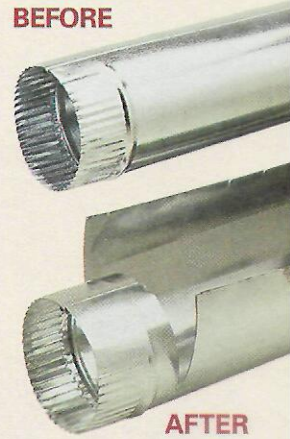

AFTER

▲ It's easy to make the metal covering for the dust trough. Start with a 4"-dia. metal pipe (top) and then cut two flaps as in the lower photo.

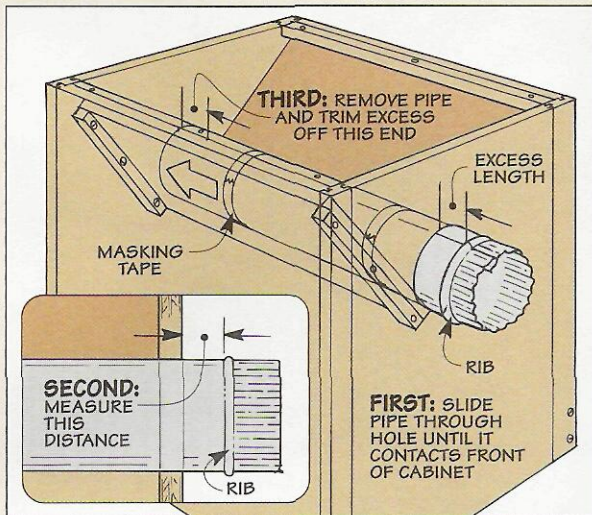

1 To determine the length of the pipe, slide it into the cabinet. Then after measuring from the back of the cabinet to the rib, remove the pipe and trim the excess.

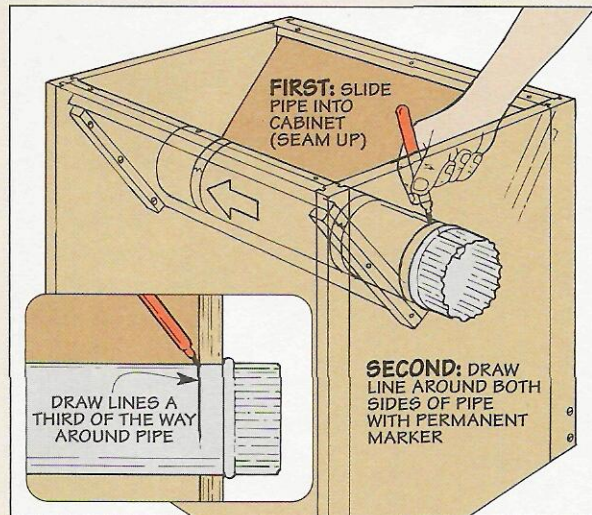

2 Now reinstall the pipe with the seam facing up and draw a line around each side. Each mark should extend about a third of the way around the pipe.

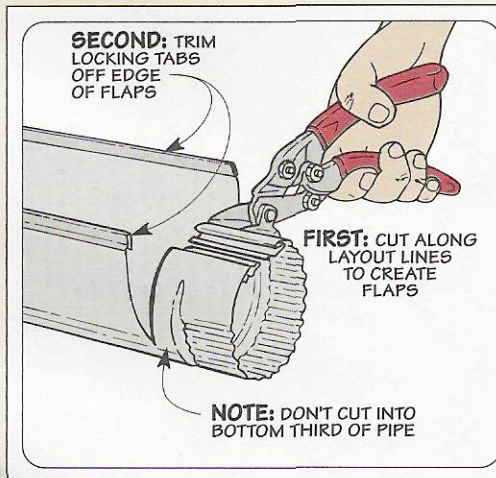

3 Using a pair of tin snips, cut along the layout lines to create a flap on each side of the pipe. After trimming the locking tab off each flap, snap the

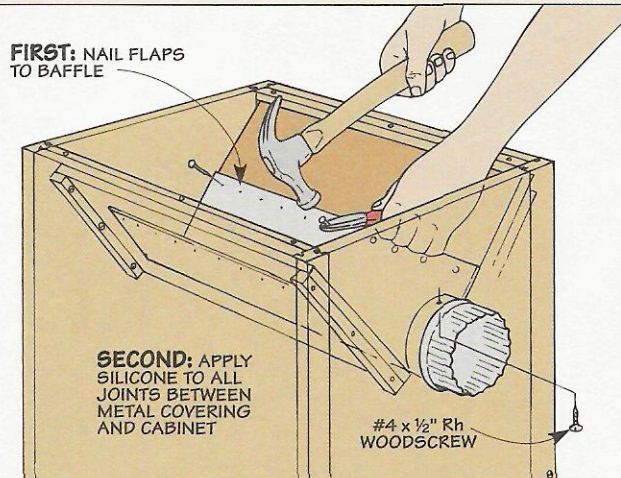

crimped end of the pipe together. Then just fit the pipe into the hole from the inside of the cabinet and nail the flaps down flat on the baffles.

Storage Cabinets

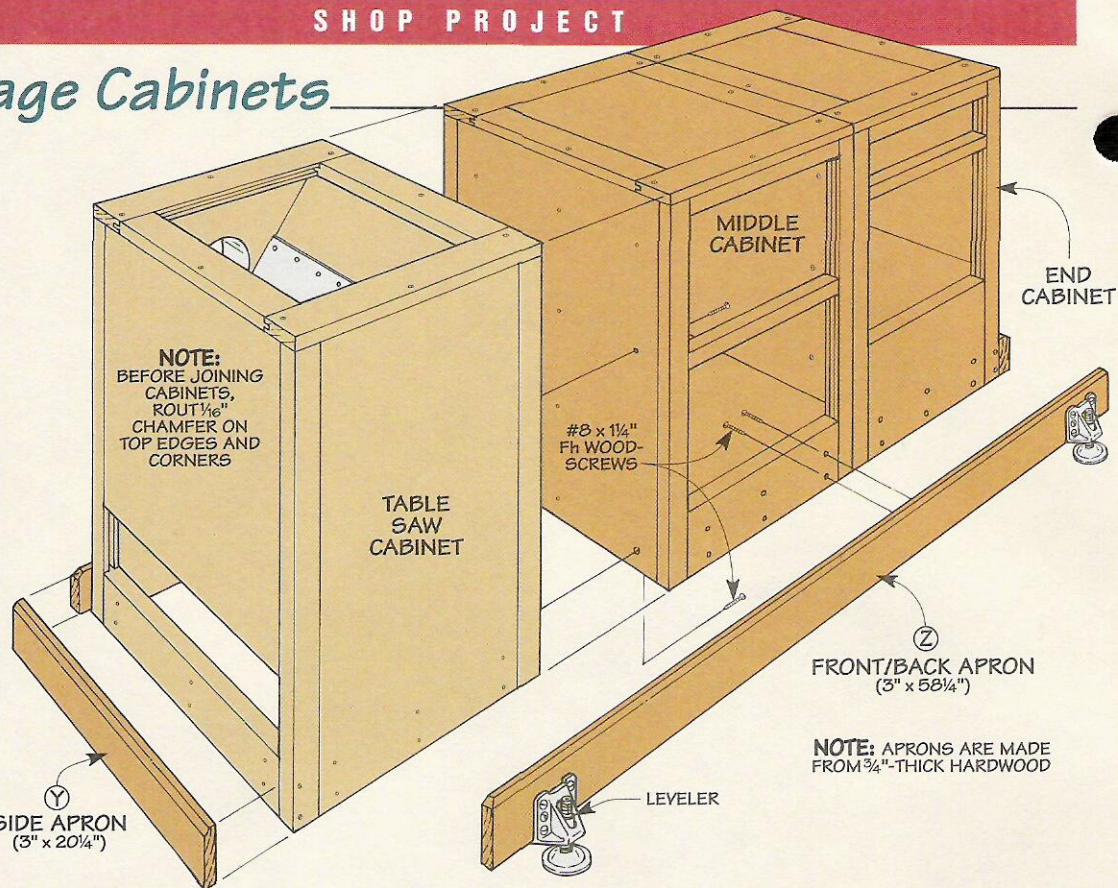
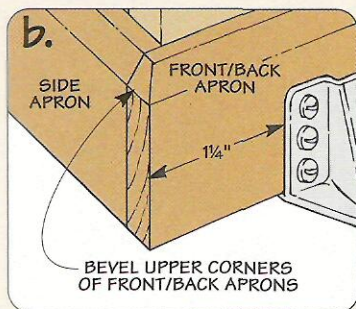
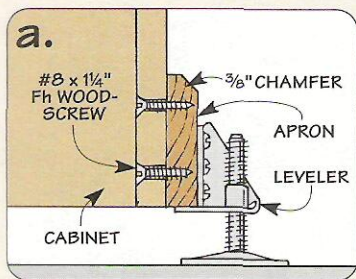

NOTE:
BEFORE JOINING
CABINETS,
ROUT $\frac{1}{16}$ "
CHAMFER ON
TOP EDGES AND
CORNERS

NOTE: APRONS ARE MADE
FROM $\frac{3}{4}$ "-THICK HARDWOOD

At this point, the table saw cabinet is almost complete. (It still needs a set of casters.) But first, to provide storage for tools and accessories, I built two more units: a *middle cabinet* and an *end cabinet*, see drawing above.

These cabinets are similar to the table saw cabinet. But there are a couple of differences worth noting.

First of all, there's a *face frame* on the front of each cabinet that forms two drawer openings. Plus, the upper part of each cabinet is completely enclosed. This creates a handy storage area on top of the cabinets once they're fastened together.

Just one more note. The *end cabinet* houses the second half of the caster system. To provide clearance

for the casters, the bottom of this cabinet sits higher than the middle one.

CABINET SIZE. The first step is to determine the overall size of the cabinets. They're identical in height and depth to the cabinet that holds the table saw. But these cabinets are a little wider.

The width of the cabinets depends on the length of the router table extension. (This is shown on page 8.) Just measure the distance from the end of the table extension to the metal saw cabinet. Then subtract 1" to allow the extension to overhang the end cabinet. This is the *combined* width of both cabinets. The width of each cabinet is *half* that distance.

CONSTRUCTION

Since these cabinets are similar to the one that holds the table saw, construction goes pretty quickly.

CABINET BACKS. Take the *back* of each cabinet for instance. As before, it's made up of a $\frac{3}{4}$ " plywood *back panel* (L) and two hardwood *corner strips* (M), see Fig. 5. Here again, these pieces are assembled with tongue and groove joints, refer to the detail in Fig. 1 on page 17.

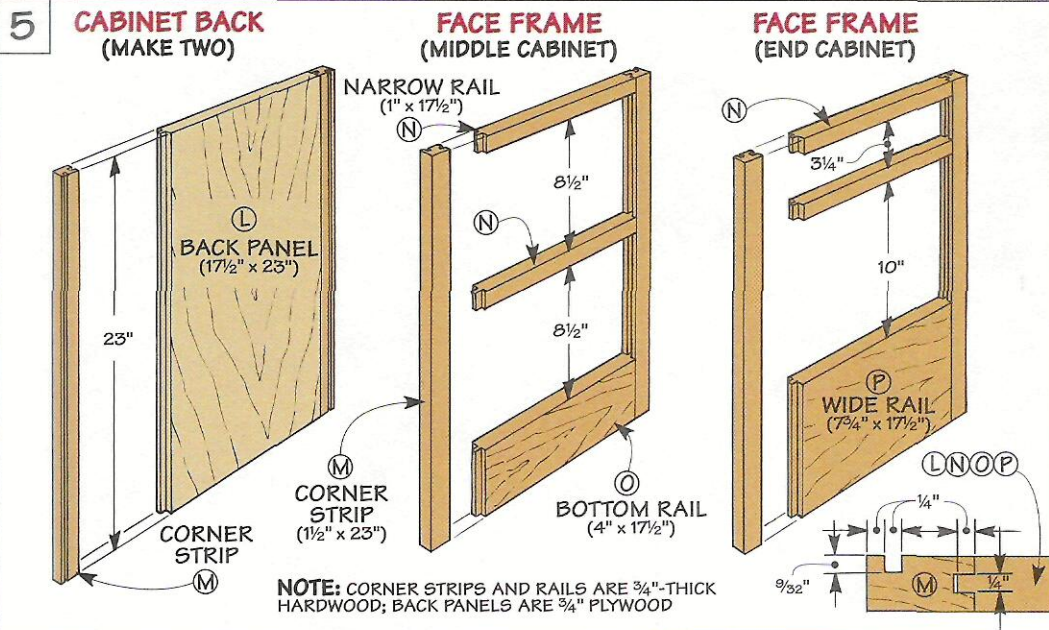

NOTE: CORNER STRIPS AND RAILS ARE $\frac{3}{4}$ "-THICK HARDWOOD; BACK PANELS ARE $\frac{3}{4}$ " PLYWOOD

FACE FRAMES. The face frames that form the fronts of the cabinets start out just like the back — with two hardwood *corner strips* (*M*), see Fig. 5. The only difference is they're connected by hardwood *rails* (*N*, *O*, and *P*) instead of a plywood panel.

These rails form the drawer openings. To hold a pair of deep drawers, I made two identical openings in the middle cabinet. And for larger items, I made an even taller opening in the face frame for the end cabinet. There's also a small opening on top of this cabinet for a shallow drawer.

The face frames are assembled with stub tenon and groove joints, see detail in Fig. 5. This requires cutting a stub (short) tenon on both ends of each rail and a groove in the edge of the corner strips.

SIDES. At this point, you're ready to add the sides. Three of the *sides* (*Q*) are identical (the two sides on the middle cabinet and the left side of the end cabinet), see Fig. 6. But once again, to form the opening that provides access to the casters, the *right side* (*R*) of the end cabinet is shorter, and a hardwood *lower rail* (*S*) spans the bottom.

As before, the sides and corner strips are assembled with tongue and groove joints. Once again, I used a tongue and dado joint to fit a plywood

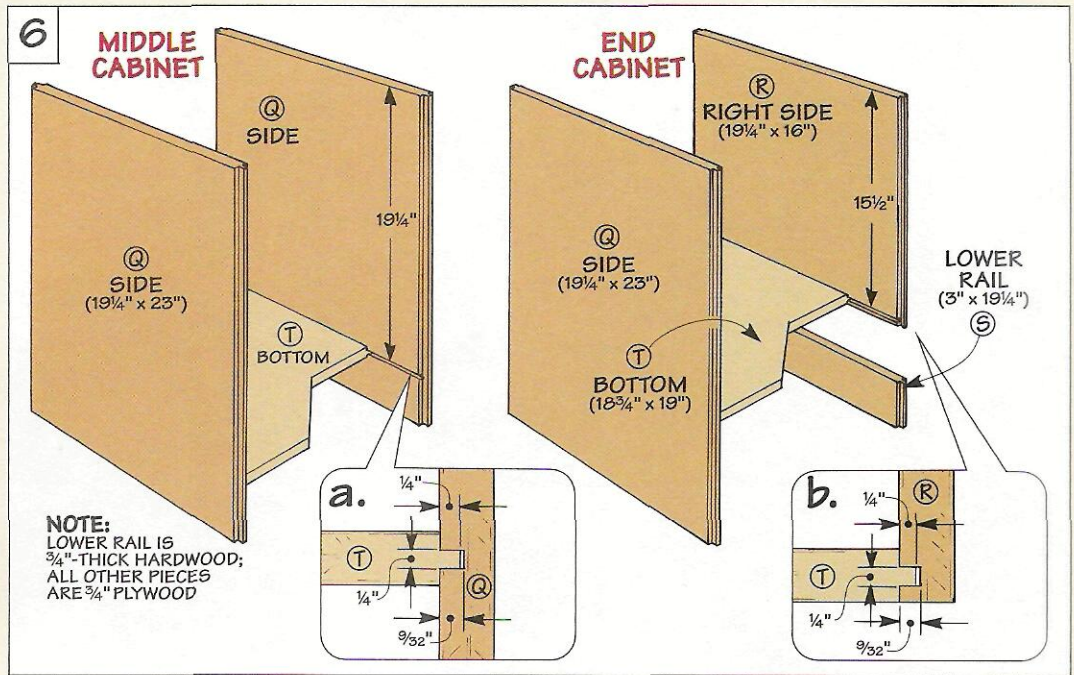

bottom (*T*) into the sides, see Figs. 6a and 6b. Note: To provide clearance for the casters, don't forget to locate the dados in the sides of the end cabinet *closer* to the top edge.

ADD THE TOPS. After gluing up each cabinet, you can turn your attention to the tops. As before, each top starts out as a solid wood frame made up of two *stiles* (*U*) and *rails* (*V*), see Fig. 7. And these frame pieces are held together with stub tenon and groove joints. But this

time, you'll need to cut a groove in *each* frame piece. These grooves accept tongues that are cut on all four edges of a plywood *top panel* (*W*).

ROUT CHAMFERS. After gluing up the tops, I routed a 1/16" chamfer around the top edges of each frame as well as the four corners of each cabinet. The chamfers create a "shadow line" when the cabinets are joined together. This way, if the cabinets don't match perfectly (mine didn't), the shadow lines make it less noticeable.

JOIN CABINETS. To join the three cabinets together, set them side by side and drive screws from inside the middle cabinet into the end cabinets, see drawing on page 20. Then, after gluing a *cleat* (*X*) to the side of each cabinet, the tops are screwed in place.

APRON. Next, to add rigidity to the base of the cabinets, I "wrapped" a wide, hardwood *apron* around them, see drawing on page 20. After routing a chamfer on the top edge of the *side* (*Y*) and *front/back apron* (*Z*) pieces, they're screwed to the cabinets from the inside, see detail 'a.' I also beveled all four corners to match the chamfers, see detail 'b.' A hand plane makes quick work of this.

LEVELERS. Now all that's left is to mount a set of four heavy-duty levelers to the cabinet, see detail 'a.'

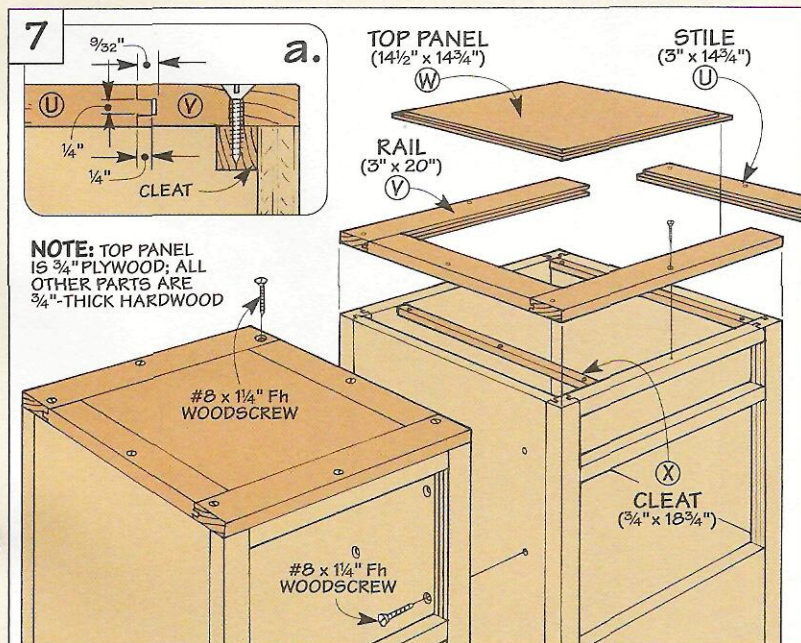

Caster System

As you'd expect, the casters on the cabinets make it easy to roll the workstation around. But they're only one part of a *caster system*. To create a solid, stable workstation, this system lets you lower the cabinets *off* the casters and onto the levelers.

CASTER ASSEMBLIES. To make this work, there are two separate caster assemblies — one inside each end of the workstation, see Fig. 8.

The casters in each assembly are mounted to a thick block that pivots up and down. This *caster block* is tilted at an angle when the workstation is resting on the levelers, see Fig. 8a. In this position, the casters just “touch” the floor which prevents the workstation from moving.

To engage the casters, you simply swing a wood *lever arm* out of the cabinet, step down on it, and slide it under a *keeper block*. This lifts the workstation off the levelers (and onto the casters) so you can roll it around, see Fig. 8b.

CASTER BLOCKS. I began by making two 1½"-thick hardwood *caster blocks* (AA), see Fig. 9. They're cut to length to fit snug (not tight) inside the cabinets so the

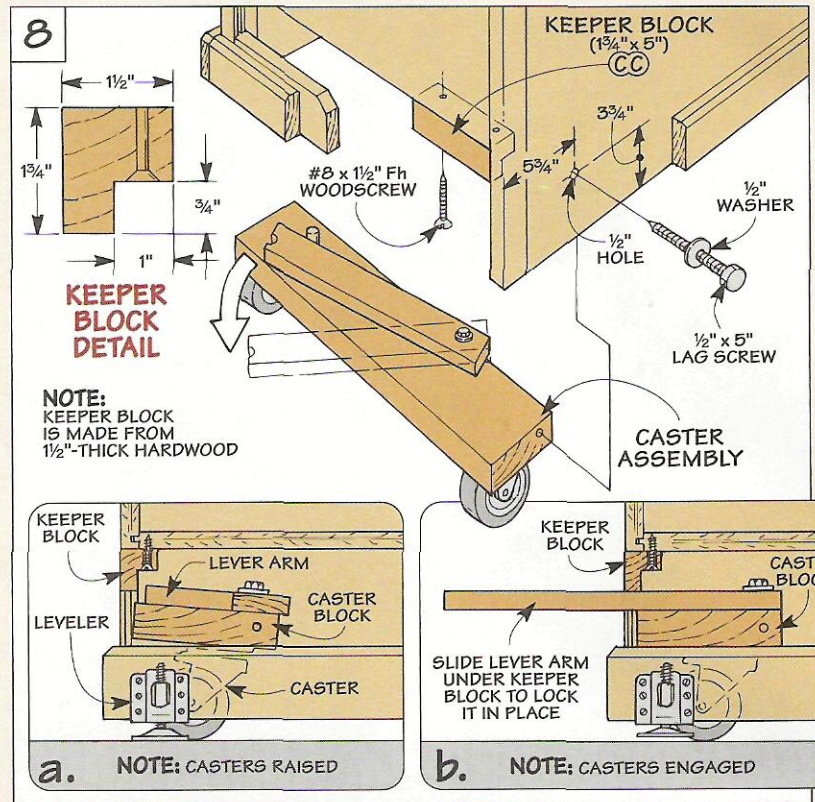

blocks can pivot without binding.

To create a pivot point, the caster blocks are attached to the cabinet with a single lag screw at each end. The lag screw passes through a shank hole in the cabinet and into a pilot hole in the end of the block, see Fig. 8.

LEVER ARM. After drilling the holes, I added the *lever arm* (BB) that raises and lowers the caster assembly, see Fig. 9. It's a piece of ¾"-thick hardwood with a circular notch cut in one end for a finger pull.

The lever arm is held in place with a bolt that passes through a hole in the arm and caster block, see Fig. 9. Threading a lock nut onto the bolt so it's just snug secures the arm yet still allows it to swing back and forth.

STOP. To prevent the arm from swinging *too* far into the cabinet where it's hard to reach, I added a stop. It's a short dowel that's glued into a hole in the caster block, see Fig. 9.

KEEPER BLOCK. Before installing the caster assembly, I added a hardwood *keeper block* (CC) to lock the lever arm in the “down” position, see Figs. 8 and 8b. To provide clearance for the caster assembly, it's rabbeted on one edge and then screwed to the cabinet.

INSTALL CASTERS. Now you can slip the caster assemblies inside the cabinet and secure them with lag screws. To prevent binding, just “snug” the screws against the cabinet.

Hardware

- (16) #8 x ¾" Fh Woodscrews
- (16) #8 x 1" Fh Woodscrews
- (172) #8 x 1¼" Fh Woodscrews
- (4) #8 x 1½" Fh Woodscrews
- (32) #6 x ½" Fh Woodscrews
- (16) #14 x 5/8" Ph Sheet Metal Screws
- (1) #4 x ½" Rh Woodscrew
- (4) Leg Levelers
- (4) 3" Casters
- (4) 5½" Pulls
- (4 Pr.) 18" Drawer Slides
- (4) ½" Lag Screws
- (4) ½" x 3" Bolts
- (8) ½" Washers
- (2) ½" Lock Nuts w/Nylon Inserts
- (1) 4" x 24" Pipe
- (1) 90° Metal Elbow
- (1) 4" Hose Clamp
- (38) 5/8" x #18 Wire Nails

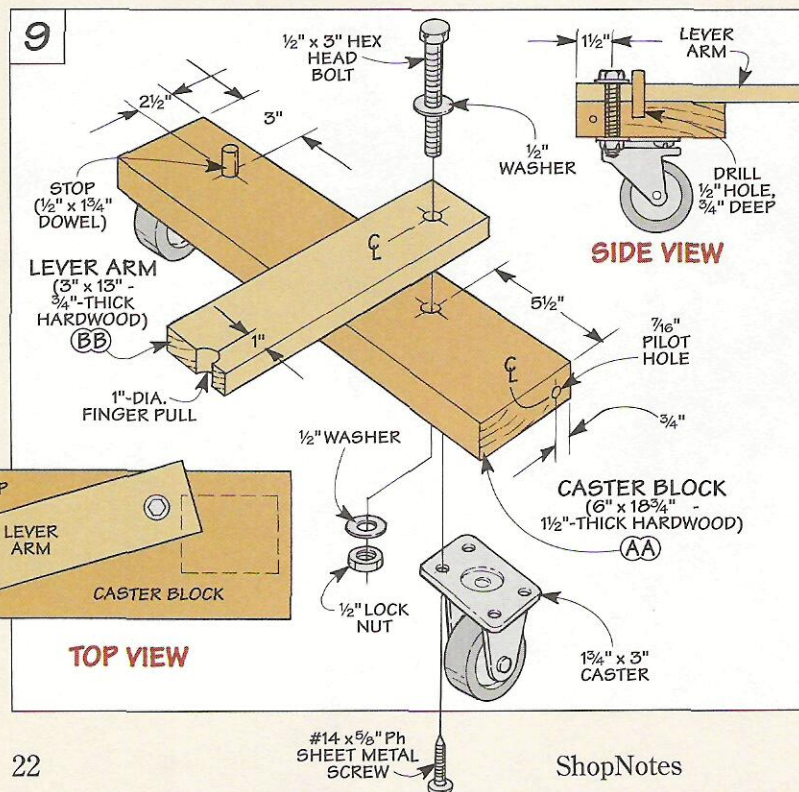

Drawers

All that's left to complete the cabinets is to add a set of four drawers.

To provide easy access to tools and supplies, each drawer is mounted on a metal slide, see Fig. 10. The drawer slides I used required a 1/2" clearance on each side. So I built 16"-wide drawers (1" less than the width of the opening). As for length, they match the length of the slides (18").

Another consideration is the *height* of the drawer. I made the shallow drawer 3" tall. And to simplify construction, all three deep drawers are the same height (7 1/2"). Note: The drawer that fits in the largest opening (the lower opening in the end cabinet) will get a *larger* false front.

DRAWER CONSTRUCTION. The drawer *front/back* (DD, FF) pieces and *sides* (EE, GG) are made of 1/2"-thick hardwood, see Fig. 11. After cutting the pieces to size, the fronts and backs are rabbeted at each end to form a tongue, see Fig. 11b. This tongue fits into a dado in each side.

Before gluing up the drawers, you'll need to cut a groove in each piece to accept a 1/4" hardboard *bottom* (HH), see Fig. 11a. It's also a good idea to drill countersunk shank holes in the drawer fronts now to make it easy to add the false fronts later.

DRAWER SLIDES. At this point, you're ready to install the drawer slides. The slides are designed to be separated into two parts. One part is attached to the drawer side. The other is mounted to a hardwood *spacer* (II) that's screwed to the cabinet sides, see Fig. 10a. The spacers "build out" the side of the cabinet so it's flush with the face frame.

FALSE FRONTS. All that's left to complete the drawers is to add the *false fronts* (JJ, KK, LL). These are pieces of 3/4" plywood trimmed with 1/2"-thick hardwood *edging* (MM). The goal is to size the false fronts so that once the edging is glued on, they overlap the drawer opening a 1/4" all the way around, see Fig. 11a. After screwing the false fronts in place, I added a pull to each drawer.

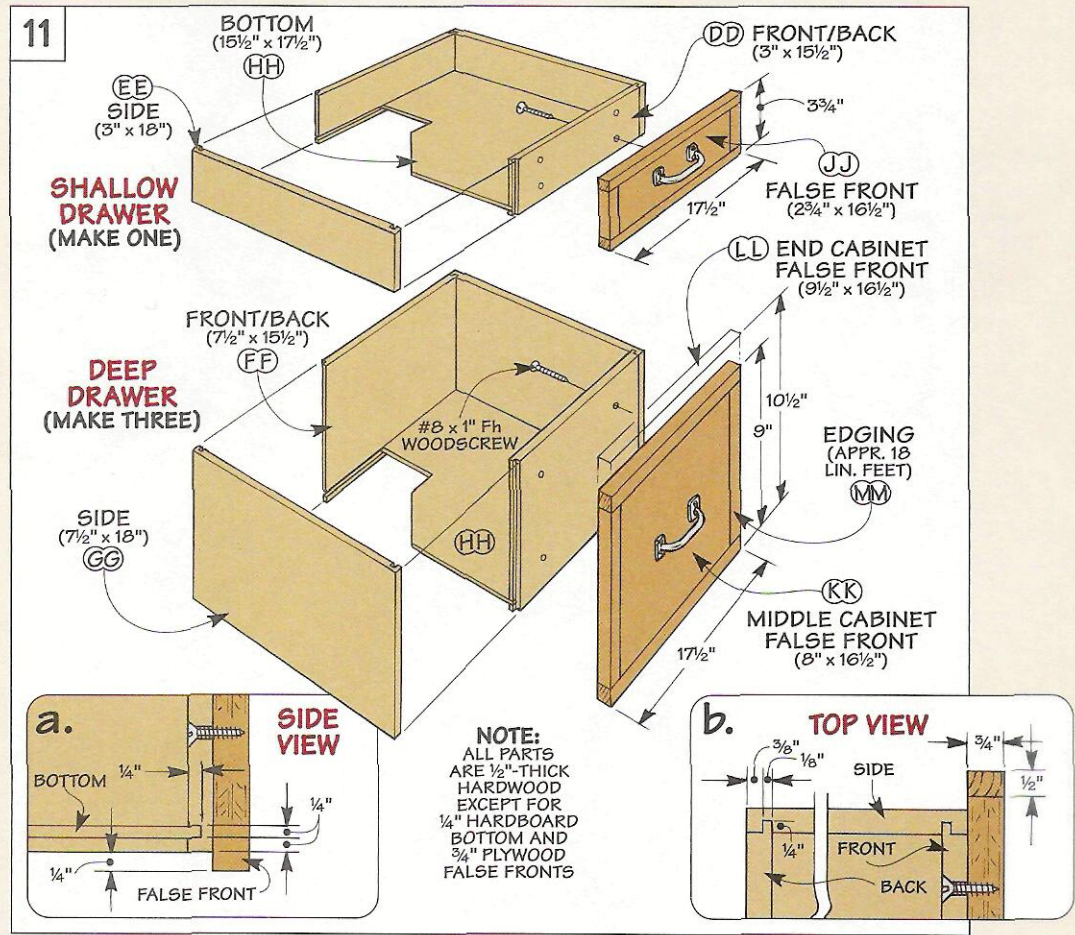
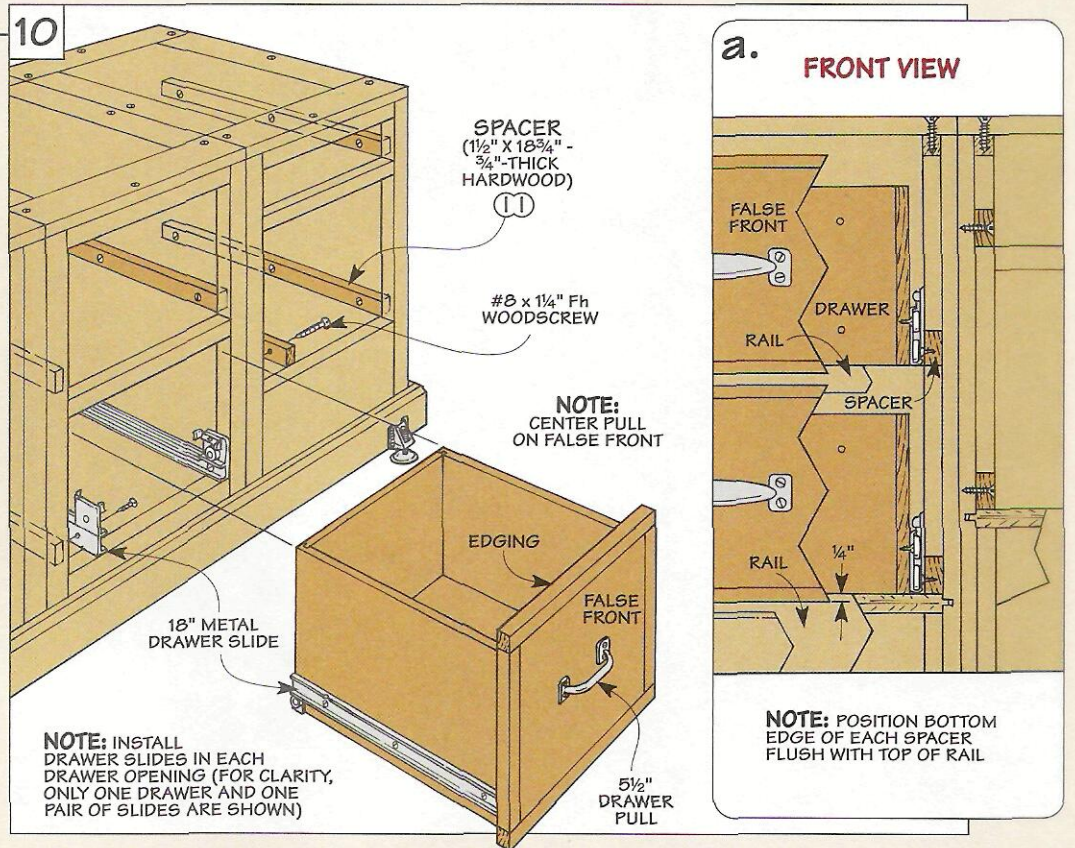

Tongue & Groove

Joining Plywood To Solid Wood

Here's a simple way to assemble the plywood sides of a cabinet — use a solid wood corner and a tongue and groove joint.

When building the table saw cabinets featured on page 16, I assembled them with tongue and groove joints. The reason is simple. It provided a quick way to create a set of strong, sturdy cabinets.

If you look at the photo on the right, it's easy to see how the tongue and groove joints in these cabinets fit together. The tongue is cut on the edge of a plywood panel, and the mating groove is cut in a solid wood corner strip.

STRENGTH. What makes a tongue and groove joint so strong? First of all, it adds *mechanical strength* to the joint. And second, it increases the amount of *glue surface* between the plywood and the solid wood corner. Once the pieces are assembled, the resulting joint is extremely strong.

SOLID WOOD. Okay, but why bother using a piece of solid wood to connect the two plywood panels? Why not just cut a tongue in one panel and a groove in the other?

One reason is the solid wood corner covers the exposed edges of the plywood. In addition to hiding the internal plies of the plywood, it also adds rigidity to the corners of the cabinets.

MAKING THE TONGUE

I usually start by making the tongue. It's easier for me to "tweak" the width of the groove to fit the tongue than the other way around. Typically, the tongue is centered on the thickness of the plywood panel by cutting two rabbets — one on each face.

There are a number of ways to cut these rabbets. Since the panels on these cabinets are fairly large, I found it easiest to clamp them to the bench and use a hand-held router with a rabbet bit, see Fig. 1.

The router is guided by a bearing on the bit that rides against the edge

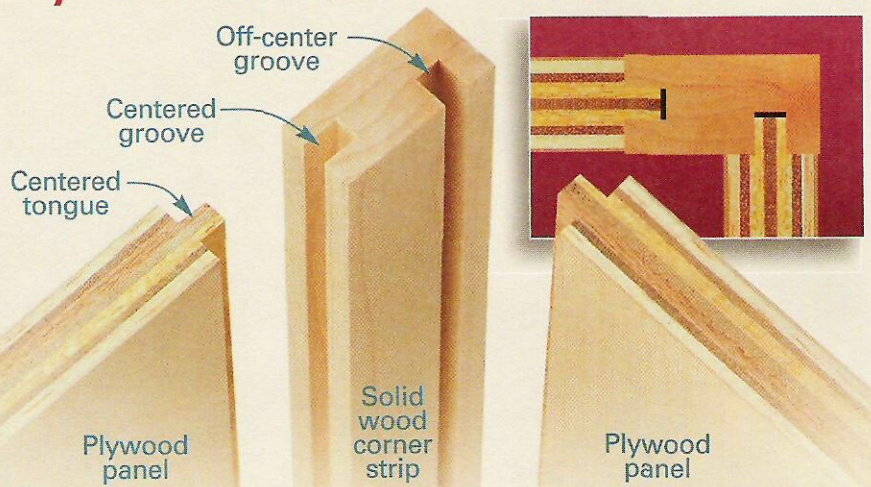

of the workpiece, see Fig. 1a. By changing the size of the bearing (or bit), you can vary the length of the tongue. (In most cases, I cut a 1/4"-long tongue.)

TONGUE THICKNESS. Another thing to consider is the *thickness* of the tongue. There's nothing critical about the exact thickness. (Later, the groove will be cut to fit.) A good rule of thumb is to adjust the depth of cut so the tongue is about one third the thickness of the plywood.

ROUT TONGUE. Now you're ready to rout the tongue. Be sure the workpiece is clamped securely. Then turn the router on and make a pass from left to right, see Fig. 1. To complete the tongue, flip the workpiece over and make a second pass.

A sharp rabbet bit generally produces a nice, clean cut — *if* you're routing with the grain. But if you're making a cross-grain cut, the bit has a tendency to tear out the wood fibers. This produces a "fuzzy" cut along the shoulder of the rabbet.

SCORING CUT. One thing that helps produce a clean cut is to score the shoulder of the rabbet with a knife before routing the tongue. To make this cut accurately, I use a simple guide. It's just a scrap piece that's routed with an identical rabbet, see margin. The rabbet posi-

tions the edge of the scrap along the shoulder of the tongue so you can score an accurate line.

CENTERED GROOVES

Once the tongue is complete, the next step is to cut the grooves in the solid wood corner strip. If the tongue fits into the *edge* of the corner strip, you'll want to cut a *centered* groove.

Now you'd expect this would make the surfaces of the corner strip and the plywood perfectly flush — *if* both pieces are identical in thickness. So it's tempting to plane the corner strip to match the thickness of the plywood. But there's a problem.

Sometimes the thickness of plywood will vary from one part of the sheet to another. Even a small discrepancy will expose part of the plywood edge. So I start with corner strips that are 1/32" *thicker* than the plywood.

This means the face of the corner strip will sit just a bit "proud" of the plywood on *both* sides, see inset photo. It's only about 1/64", and it may seem like splitting hairs. But when it's time to sand the corner strip flush, it makes things considerably easier.

To cut the grooves, I use a combination blade in the table saw. As usual, it's a good idea to make test cuts on a scrap piece. Just be sure they're the same thickness as the "real" workpiece.

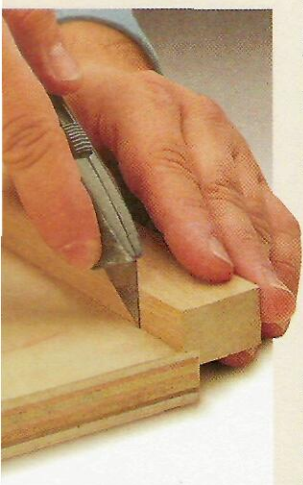

▲ To eliminate tearout, use a rabbeted block as a guide and score the shoulder of the tongue with a sharp knife.

BLADE HEIGHT. The first step is to adjust the height of the blade. To allow room for excess glue, I set the blade to cut a groove that's about $\frac{1}{32}$ " deeper than the length of the tongue.

POSITION FENCE. Now it's just a matter of positioning the rip fence to locate the groove. To cut a groove that's centered *exactly* on the edge, I use a simple trick.

Start by *roughly* centering the edge of the scrap piece on the blade and then locking the fence, see Fig. 2a. The idea here is to make *two* passes. The first pass is made with one face against the fence, see Figs. 2 and 2a. Then the scrap piece is flipped end for end so the *opposite* face is against the fence, see Fig. 2b. Note: I use a featherboard to hold the scrap against the fence.

TEST FIT. Although this produces a centered groove, it may not be wide enough to accept the tongue. So you may need to move the fence a hair *closer* to the blade and make two more passes. Continue like this until the tongue slips into the groove with a friction fit. Then cut the grooves in the actual workpieces.

OFF-CENTER GROOVES

Another type of tongue and groove joint is one with an *off-center* groove. As before, the tongue is centered on the plywood. But this time the groove is cut in the *face* of the corner strip on the adjoining plywood panel.

Here again, I make multiple passes

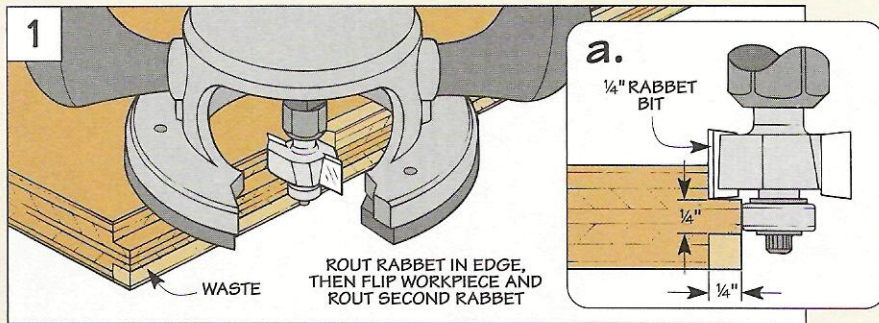

on the table saw. But this time, I make each cut with the *same* edge of the corner strip against the fence.

As before, the goal is to locate the groove so the corner strip sticks up $\frac{1}{64}$ " above the surface of the plywood. To accomplish that, I make cuts from the *inside out*. I know, it sounds confusing. But it has to do with sneaking up on the cut.

Let me explain. You could measure the distance between the tongue and the outside face of the plywood and try to duplicate this distance between the fence and the blade.

But even if you get the right measurement and make the cut, you can't test the fit of the tongue in the groove until the rest of the waste is removed. And *that* requires moving the fence.

TEST CUTS. An easy way to get around this is to make test cuts in a scrap piece. To do this, start by measuring the distance from the outside face of the plywood to the *opposite* side of the tongue. Then set the fence to cut about $\frac{1}{8}$ " *far-*

ther in from the edge than needed, see Fig. 3a.

Why not set the fence right on the money? Because all you're really trying to do is remove some of the waste. This will provide clearance for the tongue as you sneak up on the location for the *outer* side of the groove.

To do this, keep nudging the fence closer to the blade until the tongue fits in the groove and the scrap piece forms a tiny lip above the plywood, see Fig. 3b. At this point, make a single pass on *all* the pieces that require off-center grooves. In addition, you'll want to make this same cut in a *second* scrap piece.

The idea of this second scrap piece is to use it to determine the location of the *inner* side of the groove, see Fig. 3c. This is just a matter of nudging the fence *away* from the blade, making a pass, and checking the fit of the tongue in the groove. Once the groove in the scrap piece fits, simply complete the grooves in the actual workpieces.

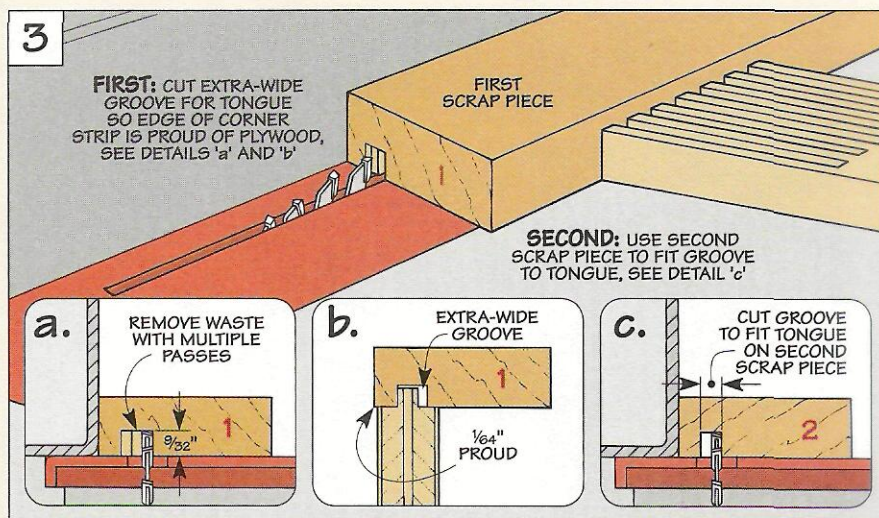
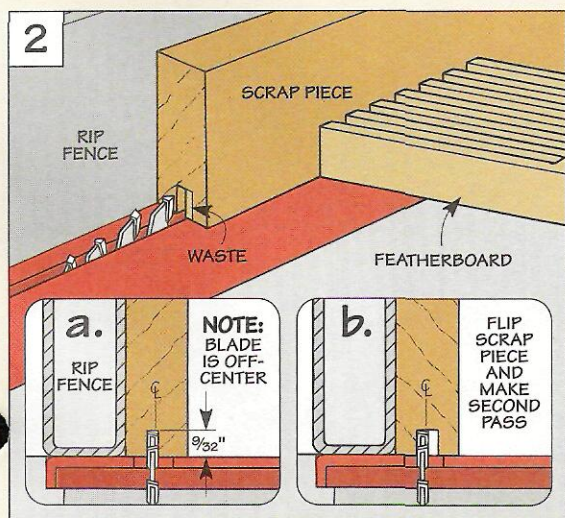

Fold-Up Outfeed Table

It only takes a minute to hook this outfeed table onto your table saw. Plus it folds flat for compact storage.

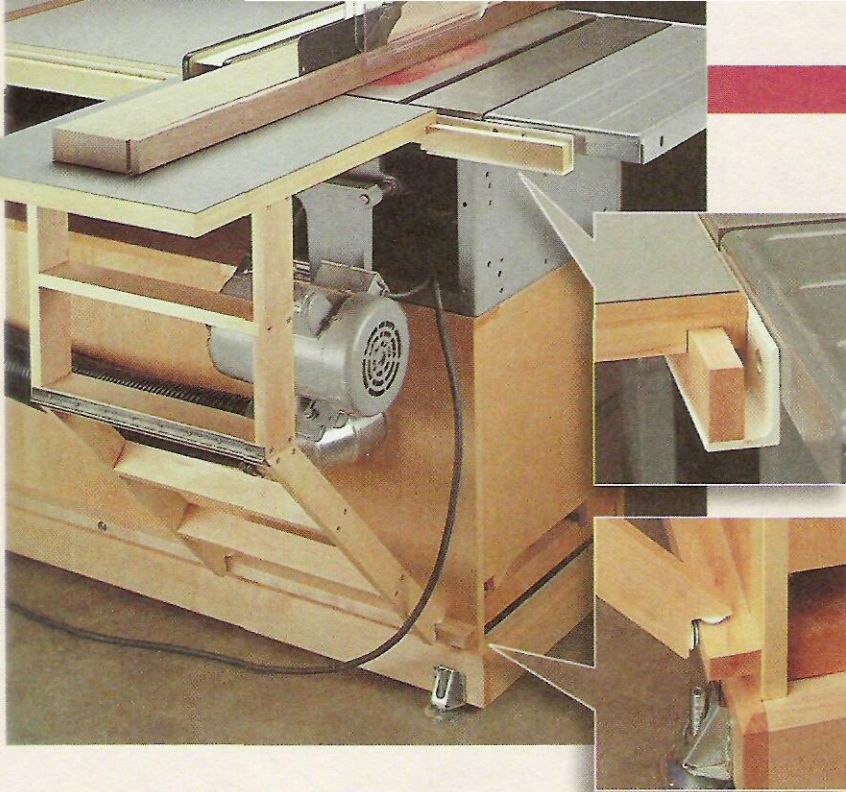

Iwish I could take all the credit for this outfeed table, but I can't. Actually, the idea came about when I was poking around in Ted's shop. (Ted is our creative director.)

To provide support when ripping long boards, he built an outfeed table to use with the T-square rip fence on his table saw. The table simply hooks over a couple of wood strips on the back of the saw.

There are a couple of things I like about his table. First of all, it's easy to reposition the table by sliding it along the wood strips. Plus, it only takes a minute to attach it to the saw (or remove it altogether).

Well, to make a long story short, I decided to build a similar outfeed table for the workstation featured in this issue, see photo above.

QUICK SETUP. Like the original version, this outfeed table attaches to the saw quickly and easily. The table hooks over a wood rail that's mounted to the metal support rail on back of the table saw, see upper inset photo. (The metal rail is part of the rip fence system.) And the ends of the ladder-like support for the table fit over another wood rail attached near the bottom of the cabinets, see lower inset photo.

There's a big advantage to this type of support system. Unlike an outfeed table that stands on the floor, the rails automatically level the table each time you set it up. So there's no need to worry about aligning it with the cast iron surface of the table saw.

REPOSITIONING TABLE. The rails also provide a quick way of repositioning the table to accommodate workpieces of different widths. Depending on the type of blade guard and splitter on your table saw, there are two ways to go about this.

If this assembly extends around the back edge of the saw, you'll need to cut an opening in the table as shown in the photo on page 27. In this case, simply lift the table off the rails and

reposition it in another location.

But if the back edge of the saw is unobstructed (as with an overhead blade guard), it's just a matter of sliding the table along the rails.

COMPACT STORAGE. Regardless of the method used to reposition the table, you may want to remove it when it's not in use. Here's one place where I made an improvement on Ted's table. Since the shape of the angled support would make it awkward to store, it's designed to fold up flat, see photo at left.

TABLE

I began by making the table that "catches" the workpiece as it slides off the table saw. There's nothing critical about the size of the table. Just be sure it's large enough to provide adequate support, yet not so big that it's unwieldy to handle. (I made the table 18" wide and 24" long.)

TOP. The first step is to make the top (A) of the table, see upper drawing on page 27. I decided to use medium-density fiberboard (MDF) for the top. It's a flat, stable material that resists warping. Plus it's fairly inexpensive. (I picked up a quarter-sheet of 1/2" MDF at a home center for \$4.)

What's the point of using 1/2" MDF instead of 3/4"-thick material? It has to do with the amount of clearance



▲ **Compact Storage.** The outfeed table and ladder-like supports are hinged together. So the entire assembly folds up like an accordion for compact storage.

under the table. When the blade on my saw is tilted to 45°, the motor swings up quite close to the table. The extra 1/4" of space provides the clearance needed to prevent the motor from hitting the table.

EDGING. After cutting the top to size, I "wrapped" it with strips of hardwood edging (B). Besides covering the exposed edges, the strips add rigidity to the table. They're simply mitered to length and glued around the top like a picture frame.

PLASTIC LAMINATE. To create a smooth, durable surface, the top (and edging) are covered with plastic laminate. I glued on an oversize piece of laminate and then trimmed the edges with a hand-held router and flush trim bit.

At this point, the top of the table is basically complete. But the bottom still needs some work.

MOUNTING PLATE. To provide a way to attach the angled support, I added a mounting plate (C), see Step 2 in drawing above. It's just a wide piece of 3/4"-thick hardwood that's glued to the table.

FILLER STRIP. In addition to the mounting plate, you'll also need to

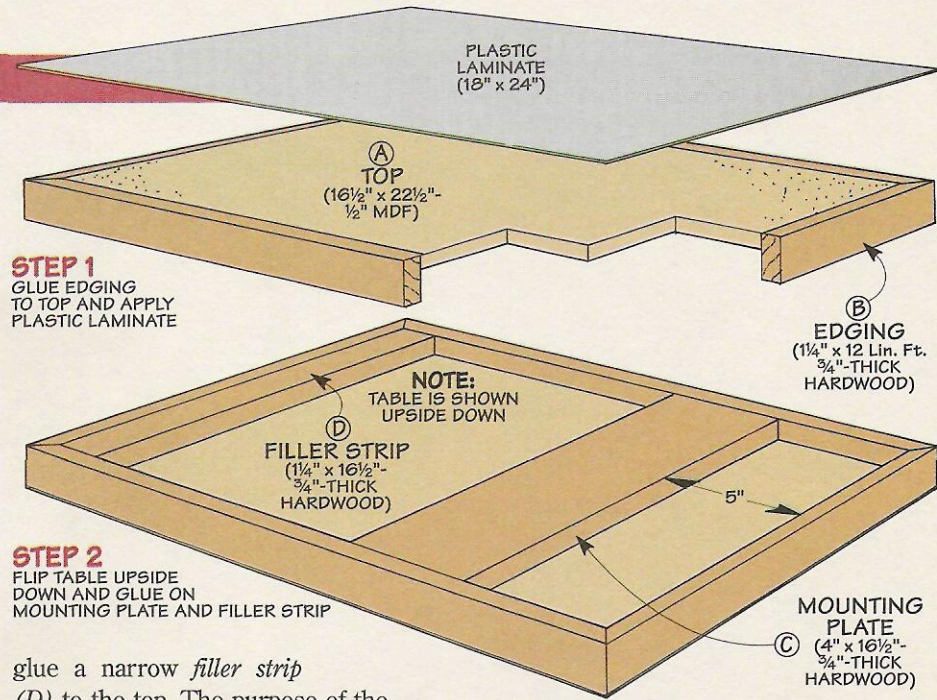

STEP 1
GLUE EDGING TO TOP AND APPLY PLASTIC LAMINATE

STEP 2
FLIP TABLE UPSIDE DOWN AND GLUE ON MOUNTING PLATE AND FILLER STRIP

glue a narrow filler strip (D) to the top. The purpose of the filler strip is to "beef up" the end of the table that hooks over the wood rail on the saw.

RAILS

Now it's time to add the two long rails that hold up the table and the folding support, see Fig. 1.

UPPER RAIL. The upper rail (E) is a strip of 3/4"-thick hardwood cut to the same length as the metal rail on the saw. To provide clearance for the motor when tilting the blade, you'll

need to notch the bottom edge of this rail. (Just cut it in the same location as the notch in the metal rail.) Then simply screw the rail in place.

LOWER RAIL. The lower rail (F) is cut to length to span the width of the workstation. After drilling counterbored shank holes in this rail, it's fastened to the cabinets with lag screws, see Fig. 1b.

CUT GROOVE. Now it's just a matter of cutting the groove in the bottom of the table that hooks onto the upper rail, see Fig. 1a. The important thing here is the depth of the groove. It should be deep enough so the table sits about 1/16" below the surface of the table saw. This way, the workpiece won't catch on the edge of the table.

Another consideration is the width of the groove. The idea is to make it wide enough to create a smooth, sliding fit. To accomplish that, I mounted a 3/4" dado blade in the table saw and shimmed it to cut a groove that's slightly wider (about 1/32") than the thickness of the upper rail.

OPENING. Now you can cut the opening for the blade guard and splitter assembly (if it's needed). This is just a matter of drilling clearance holes in the corners of the desired opening and removing the waste with a sabre saw.



▲ A large opening in the end of the table provides clearance for the blade guard and splitter assembly.

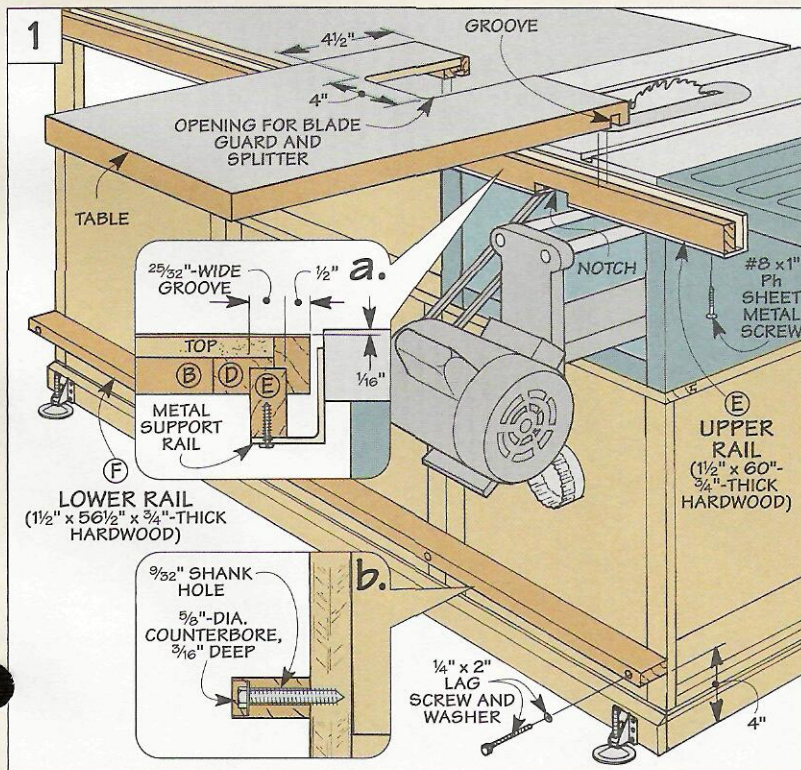

Folding Support

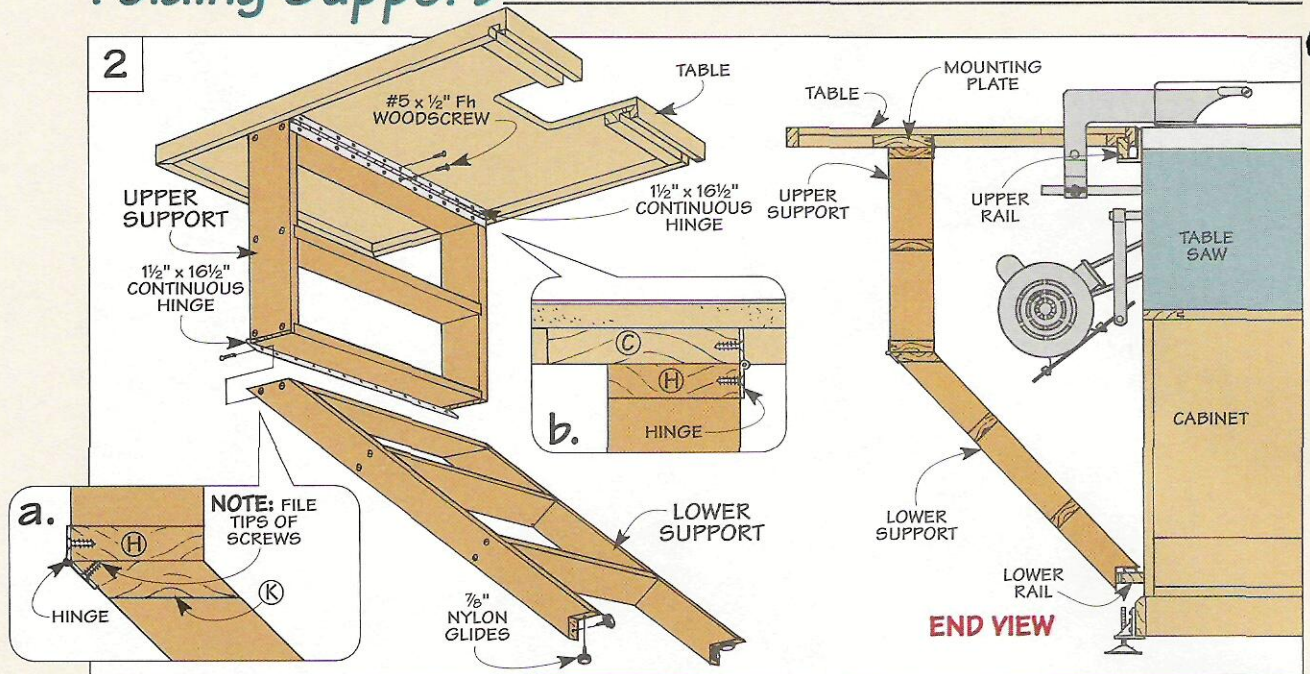

One of the handiest features of this outfeed table is the angled support that holds it up. It provides sturdy support for the table when ripping a long board. And once you're done, it folds up so you can store the table neatly out of the way.

The folding support consists of two simple wood frames that are hinged together at an angle, see Figs. 2 and 2a. An *upper support* is hinged to the bottom of the table, see Fig. 2b. This support is "locked" in a vertical position by a *lower*

support that's propped at an angle against the table saw cabinets.

UPPER SUPPORT

I began by making the *upper support*. The overall width of this support matches the distance between the edging on the sides of the table. (In my case, this was 16 1/2".) As for height, it needs to extend down far enough so when the lower (angled) support is attached, there's plenty of clearance around the motor, see End View in Fig. 2. (I made it 13" tall.)

The first step is to rip enough 3/4"-thick hardwood stock to width to make two *sides* (G) and three *rails* (H), see Fig. 3. The top and bottom rails fit in rabbets cut in both ends of each side. You'll also need to cut a centered dado in each side to hold the middle rail.

ASSEMBLY. After completing the joinery, the sides and rails are simply glued and screwed together. Then to allow the upper support to fold down, I hinged it to the mounting plate (C) on the table, see Fig. 2b.

LOWER SUPPORT

Once the upper support is in place, you're halfway done. Now you can turn your attention to the angled *lower support*, see Fig. 2.

The lower support is made up of two narrow *legs* that are connected with three *rails*, like rungs on a ladder, refer to Fig. 5. In use, the legs rest on the lower rail (F) that was attached earlier to the cabinets.

ANGLED NOTCH. To fit the legs on the rail, there's an angled notch in the *bottom* end of each one, see Figs. 4a and 4b. I cut these notches in two extra-long workpieces. Later, this provides an easy way to lay out the angle on the *top* end of the legs.

When you cut the notches, it will

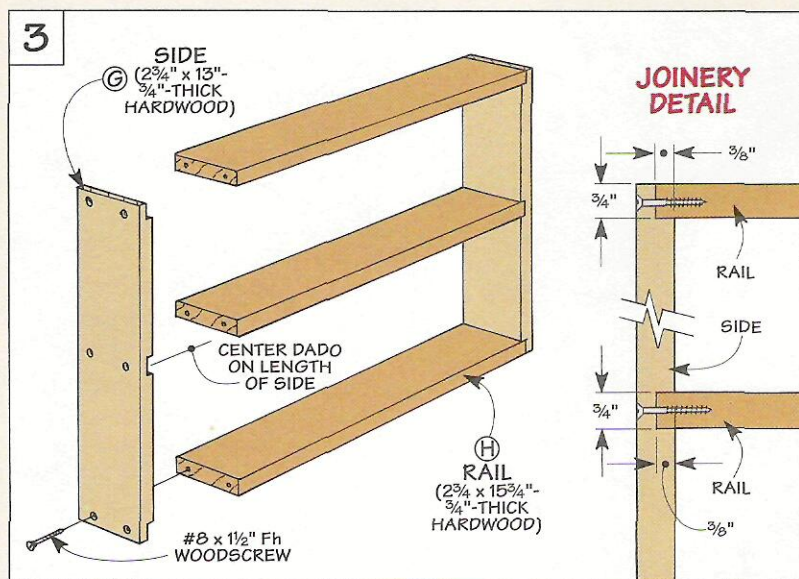

create two pointed tips that are pretty fragile. So I “knocked off” the tips to keep them from splintering if the support gets banged around.

NYLON GLIDES. The next step is to add a pair of nylon glides, one on each side of the notch, see margin. These glides make the legs slide smoothly on the lower rail.

LAY OUT ANGLE. After tacking the glides in place, you’re ready to lay out the angle on the *top* end of the sides. To get accurate results, it’s best to temporarily install the table and “test fit” one of the legs.

Start by hooking one end of the table over the upper rail and propping up the other end with a clamp, see Fig. 4. The goal is to make the surfaces of the outfeed table and table saw *parallel* to each other. So you may need to shim under the clamp.

Now position one of the legs against the upper support like it will be when the table is in use. To do this, set the notched end of the leg on the lower rail and clamp the top end against the upper support, see Fig. 4c. Then simply mark the angle across the inside face of the leg.

TRIM TO LENGTH. After laying out the angles on both pieces, you’re ready to trim the legs to final length. To do this, tilt the miter gauge on the table saw to match the angle of the layout line on the legs. Then miter the *legs* (I) to length, see Fig. 5.

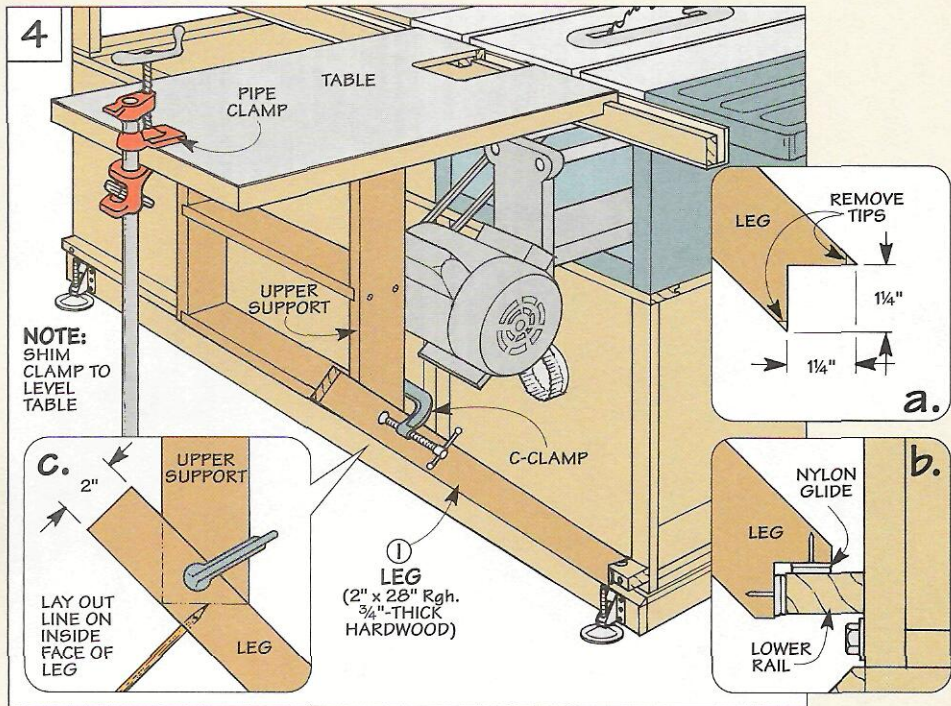

RABBET ENDS. To accept a wide top rail that’s added later, you’ll also need to cut a rabbet in the mitered ends of the legs. There’s no need to adjust the angle of the miter gauge. I just mounted a dado blade in the table saw and used the same miter gauge setup to rabbet the ends.

CUT DADOES. The dado blade comes in handy for the next step as well — cutting a pair of dados in each leg to accept the other two rails of the lower support. Only this time, you’ll need to tilt the head of the

miter gauge back to 90°.

RAILS. At this point, it’s time to add the three *rails* that connect the legs. I ripped two *narrow rails* (J) to match the width of the legs. And a wide *top rail* (K) fits into the rabbets in the legs. This top rail is beveled on both edges so it fits flush with the legs.

ASSEMBLY. Now it’s just a matter of assembling the lower support with glue and screws. Here again, I used a long hinge to connect the two supports, see Fig. 2a.

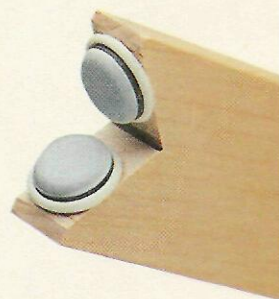

▲ Adding two nylon furniture glides to the notched end of each leg allows the lower support to slide smoothly on the lower rail.

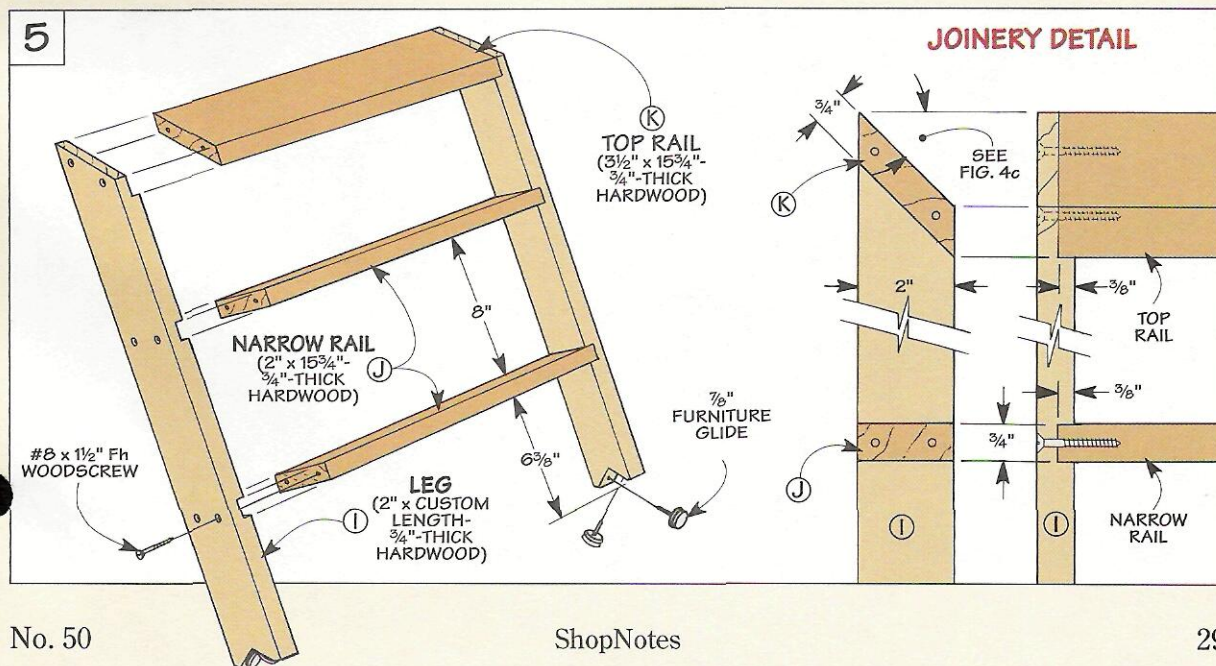

Tool Talk

TOOLS OF THE TRADE

T-Square Rip Fence

I've never been completely satisfied with the rip fence on my table saw. One reason is I can only rip material up to 25" wide. But what's even more frustrating is the fence doesn't always lock parallel to the saw blade. So I have to measure the distance from the fence to the front *and* the back of the blade every time I make a cut.

Finally, I got tired of fiddling with it, and I decided to replace it with a more accurate fence that had a larger rip capacity.

BIESEMEYER. After looking at several after-market models, I bought a T-square fence manufactured by Biesemeyer, see photo above. This fence has a 40" rip capacity, but other sizes are also available, see page 31.

RUGGED CONSTRUCTION. One of the things I like about this fence is its rugged construction. The *core* of the fence is made of thick, square steel tubing, see drawing below. A plywood *face* covered with plastic laminate is attached to each side of the tubing. And a beefy chunk of angle iron is welded to the bottom to form

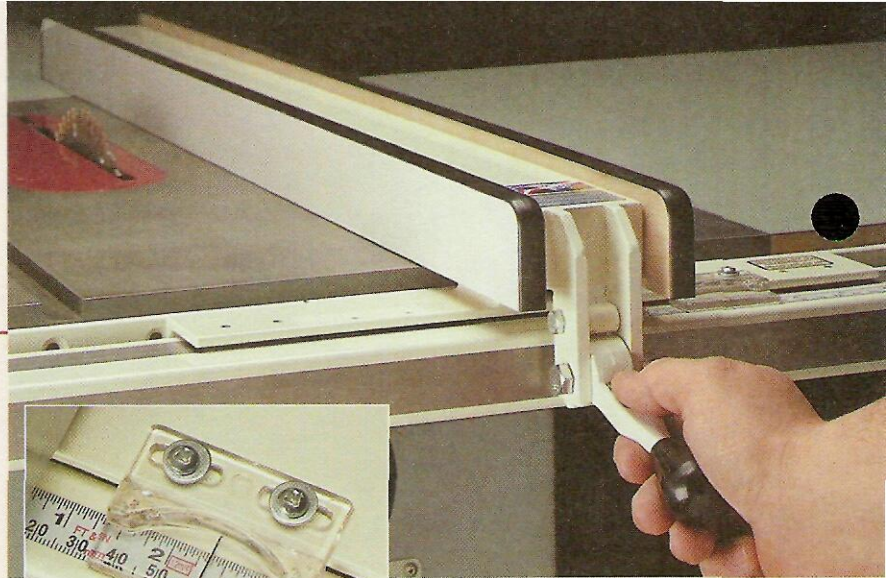

▲ With the fence unlocked, it simply lifts off the guide tube. When you set it back in place, it still locks parallel to the saw blade.

the T-square *head* of the fence.

To align the fence parallel to the blade, there's an adjustment screw in each end of the head. The fence has to be removed to adjust the screws, so it's a trial and error process. But once the screws are set, the fence *stays* perfectly aligned.

To provide rigid support for the head, it rides on a heavy-duty, steel guide tube. This guide tube is attached to an angle iron support rail that's bolted to the front of the table saw (and table extension). A second rail mounted to the *back* of the saw supports the table extension only. Note: The fence *doesn't* lock on this second rail.

LOCKING MECHANISM. But what impresses me the most about this fence is the *locking mechanism*. Not just because the fence doesn't budge when it's locked. But because it locks parallel to the blade every time.

Here's how it works. With the lock lever *up*, slide the fence to its desired position, see detail 'a.' (A scale and hairline make this quick and easy, see inset photo.) When you push the lever *down*, a cam on the end exerts pressure that draws the head tightly against the guide tube, see detail 'b.'

PRICE. Okay, so how much does this fence cost? I paid \$269 (about half of what I paid for my table saw). Even so, the fence makes such a dramatic improvement in the overall performance of the saw, it's worth every penny. 🛠️

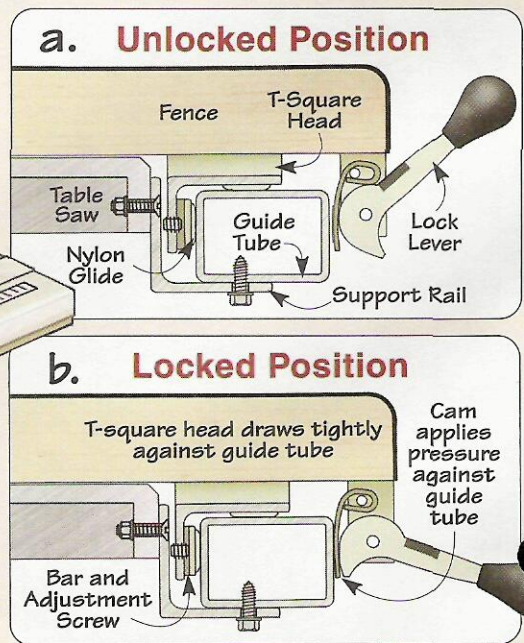
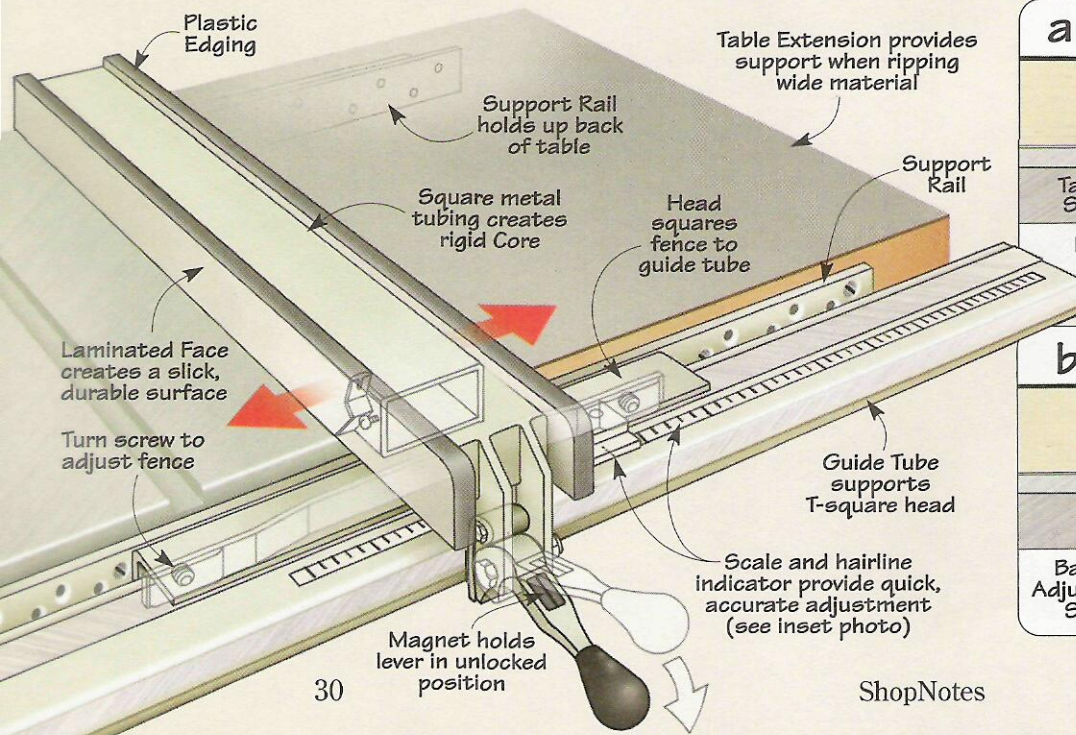

Sources

PRODUCT INFORMATION

ShopNotes Project Supplies is offering some of the hardware and supplies needed to build the projects in this issue. We've also put together a list of other mail-order sources that have similar hardware and supplies.

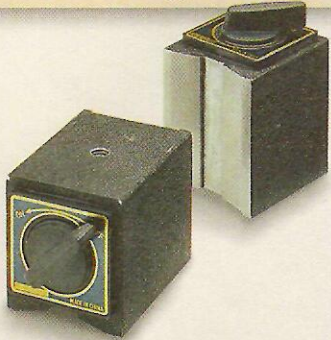

▲ Magnetic Bases

The featherboard shown on page 4 is "clamped" to the table saw with two magnetic bases that you can turn on or off with the flip of a switch.

The magnetic bases cost \$11.95 each. I bought mine from Enco Manufacturing at 800-873-3626. (Part No. 625-0930)

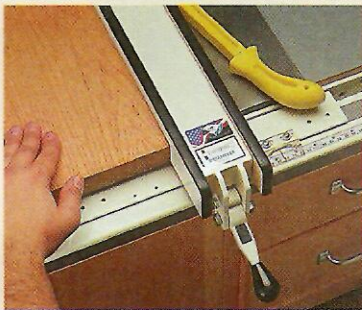

▲ T-Square Rip Fence

The T-Square rip fence (page 30) is available with rip capacities of 28", 40", or 52". If your table saw measures a minimum of 20" from front to back, has a cast-iron top with a flat front edge at least 1 1/4" in height, then the fence can be adapted to your saw. (See margin for sources.)

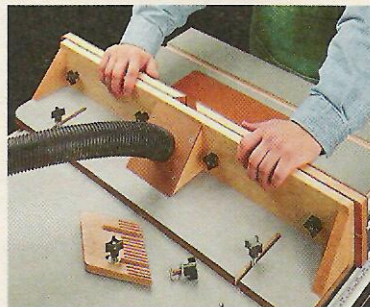

Table Saw Workstation Kit ▶

The Table Saw Workstation that's featured on page 6 is a great way to upgrade your table saw.

ShopNotes Project Supplies is offering a complete hardware kit to build the table saw cabinets, the router table extension, and the outfeed table. Note: It doesn't include the rip fence or the optional hardware for the electrical switch. You'll also need to provide the hardwood, sheet material, and plastic laminate.

TABLE SAW WORKSTATION KIT
6850-100.....\$218.95



▲ Router Table Extension

If you'd like to build the Router Table Extension (page 8) by itself, we're offering a separate kit with all the hardware you need. Note: Vacuum hose isn't included. All you need to supply is the hardwood, hardboard, MDF, and plastic laminate.

ROUTER TABLE EXTENSION KIT
6850-175.....\$39.95



▲ Table Saw Cabinets

ShopNotes Project Supplies is also offering a separate kit that includes all the hardware needed to build the three table saw cabinets by themselves. All you need to supply is the hardwood, plywood, and hardboard.

TABLE SAW CABINETS KIT
6850-150.....\$179.95

MAIL ORDER SOURCES

Tool Crib
800-635-5140
T-Square Fences

Woodhaven
800-344-6657
Phenolic Plates

Woodsmith Store
800-835-5084
T-Square Fences

Woodworker's Supply
800-645-9292
T-Square Fences

ON-LINE CUSTOMER SERVICE

- Access information about your subscription account.
- Find out if your payment has been received.
- Change your mailing address or your email address.
- Let us know if you haven't received your issue.

www.shopnotes.com

TO PLACE AN ORDER CALL

800-347-5105

(KEY CODE: SN 50)

WoodNet™

- 101 Woodworking Tips Online
- Woodworking Techniques
- Project plans you can download
- WoodNet Forum
- Power Tool Reviews

www.augusthome.com

Scenes from the Shop

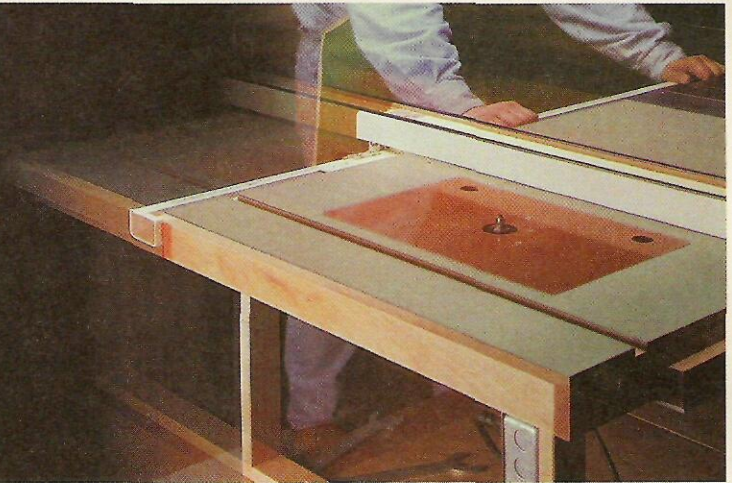
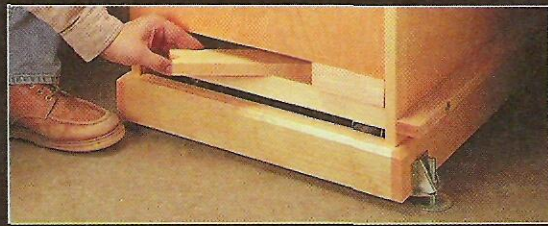

One of the secrets to getting the most efficient use out of the space in a shop is to make your stationary tools mobile. Our table saw workstation does just that. To raise

the workstation off its levelers and onto a set of casters, just pull out a wood lever and step down on it, see inset photos. Then simply roll the workstation away.



At the end of the day, it only takes a few minutes to turn your workshop back into a garage. Just fold up the outfeed table and stow it on top of the storage cabinets.

Then roll the workstation against the wall. Who knows? There may even be room for the car. (Step-by-step plans for building the table saw workstation begin on page 6.)

ShopNotes Cutting Diagram

Table Saw Cabinets

Materials - Table Saw Cabinets

Table Saw Cabinet

A	Front/Back Panels (2)	14 $\frac{1}{4}$ x 23 - $\frac{3}{4}$ Ply.
B	Corner Strips (4)	$\frac{3}{4}$ x 1 $\frac{1}{2}$ - 23 Maple
C	Left Side (1)	19 $\frac{1}{4}$ x 16 - $\frac{3}{4}$ Ply.
D	Right Side (1)	19 $\frac{1}{4}$ x 23 - $\frac{3}{4}$ Ply.
E	Bottom (1)	15 $\frac{3}{4}$ x 18 $\frac{3}{4}$ - $\frac{3}{4}$ Ply.
F	Lower Rail (1)	$\frac{3}{4}$ x 3 - 19 $\frac{1}{4}$ Maple
G	Cleats (2)	$\frac{3}{4}$ x $\frac{3}{4}$ - 18 $\frac{3}{4}$ Maple
H	Stiles (2)	$\frac{3}{4}$ x 3 - 14 $\frac{3}{4}$ Maple
I	Rails (2)	$\frac{3}{4}$ x 3 - 16 $\frac{3}{4}$ Maple
J	Baffles (2)	11 x 18 $\frac{3}{4}$ - $\frac{3}{4}$ Ply.
K	Support Strips (4)	$\frac{3}{4}$ x $\frac{3}{4}$ - 9 $\frac{3}{4}$ Maple

Storage Cabinet

L	Back Panels (2)	17 $\frac{1}{2}$ x 23 - $\frac{3}{4}$ Ply.
M	Corner Strips (8)	$\frac{3}{4}$ x 1 $\frac{1}{2}$ - 23 Maple
N	Narrow Rail (4)	$\frac{3}{4}$ x 1 - 17 $\frac{1}{2}$ Maple
O	Bottom Rail (1)	$\frac{3}{4}$ x 4 - 17 $\frac{1}{2}$ Maple
P	Wide Rail (1)	$\frac{3}{4}$ x 7 $\frac{3}{4}$ - 17 $\frac{1}{2}$ Maple
Q	Side (3)	19 $\frac{1}{4}$ x 23 - $\frac{3}{4}$ Ply.
R	Right Side (1)	19 $\frac{1}{4}$ x 16 - $\frac{3}{4}$ Ply.
S	Lower Rail (1)	$\frac{3}{4}$ x 3 - 19 $\frac{1}{4}$ Maple
T	Bottom (2)	18 $\frac{3}{4}$ x 19 - $\frac{3}{4}$ Ply.
U	Stiles (4)	$\frac{3}{4}$ x 3 - 14 $\frac{3}{4}$ Maple
V	Rails (4)	$\frac{3}{4}$ x 3 - 20 Maple
W	Top Panel (2)	14 $\frac{1}{2}$ x 14 $\frac{3}{4}$ - $\frac{3}{4}$ Ply.
X	Cleats (4)	$\frac{3}{4}$ x $\frac{3}{4}$ - 18 $\frac{3}{4}$ Maple
Y	Side Apron (2)	$\frac{3}{4}$ x 3 - 20 $\frac{1}{4}$ Maple
Z	Front/Back Apron (2)	$\frac{3}{4}$ x 3 - 58 $\frac{1}{4}$ Maple

Caster System

AA	Caster Blocks (2)	1 $\frac{1}{2}$ x 6 - 18 $\frac{3}{4}$ Maple
BB	Lever Arms (2)	$\frac{3}{4}$ x 3 - 13 Maple
CC	Keeper Blocks (2)	1 $\frac{1}{2}$ x 1 $\frac{3}{4}$ - 5 Maple

Drawers

DD	Fronts/Backs (2)	$\frac{1}{2}$ x 3 - 15 $\frac{1}{2}$ Maple
EE	Sides (2)	$\frac{1}{2}$ x 3 - 18 Maple
FF	Fronts/Backs (6)	$\frac{1}{2}$ x 7 $\frac{1}{2}$ - 15 $\frac{1}{2}$ Maple
GG	Sides (6)	$\frac{1}{2}$ x 7 $\frac{1}{2}$ - 18 Maple
HH	Bottoms (4)	15 $\frac{1}{2}$ x 17 $\frac{1}{2}$ - $\frac{1}{4}$ Hardboard
II	Spacers (8)	$\frac{3}{4}$ x 1 $\frac{1}{2}$ - 18 $\frac{3}{4}$ Maple
JJ	False Front (1)	2 $\frac{3}{4}$ x 16 $\frac{1}{2}$ - $\frac{3}{4}$ Ply.
KK	False Front (2)	8 x 16 $\frac{1}{2}$ - $\frac{3}{4}$ Ply.
LL	False Front (1)	9 $\frac{1}{2}$ x 16 $\frac{1}{2}$ - $\frac{3}{4}$ Ply.
MM	Edging	$\frac{1}{2}$ x $\frac{3}{4}$ - 18 Lin. Feet

$\frac{3}{4}$ x 48 x 96 Maple Plywood

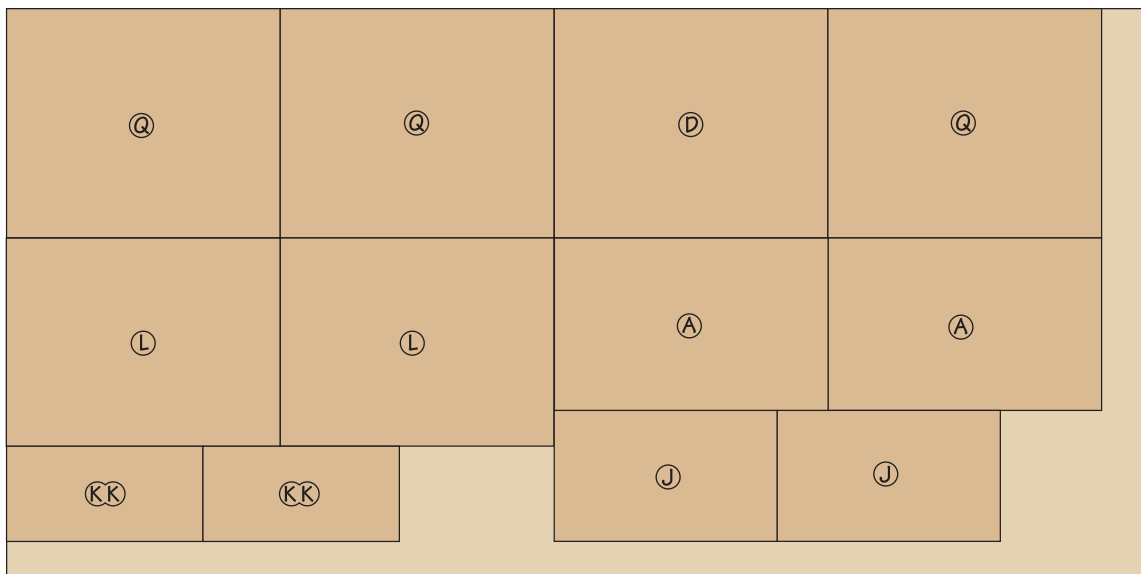

3/4 x 48 x 58 Maple Plywood

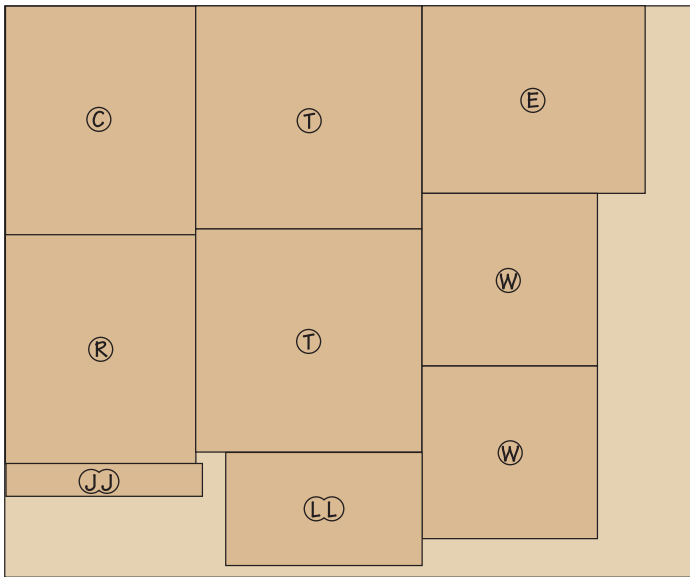

1/4 x 48 x 48 Hardboard

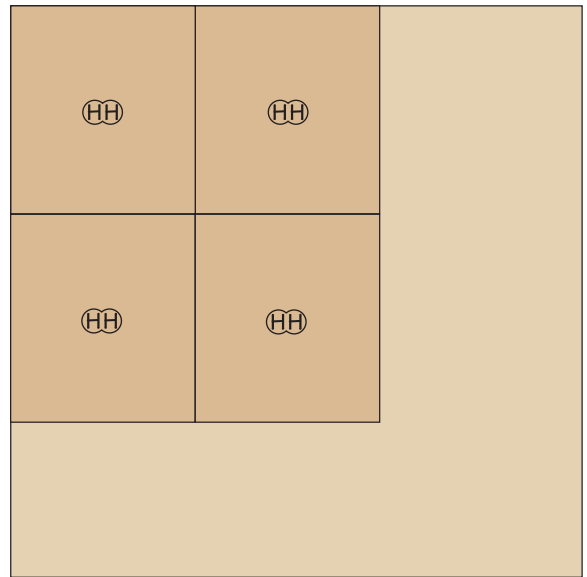

1/2 x 8 - 96 Maple



1/2 x 8 - 96 Maple (Two Boards)



3/4 x 8 1/2 - 96 Maple

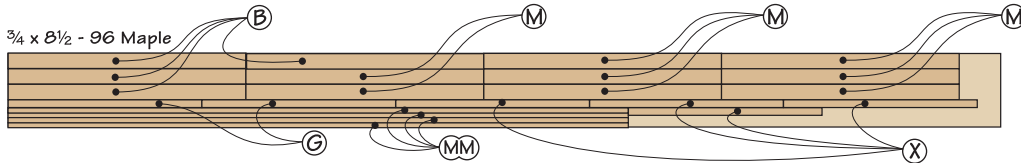

3/4 x 6 1/2 - 96 Maple (Two Boards)

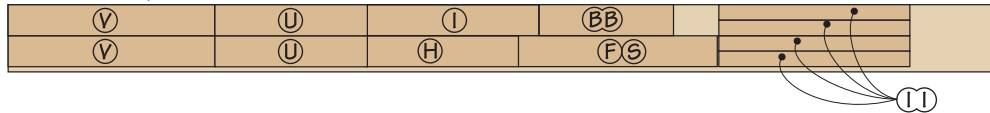

3/4 x 9 3/4 - 96 Maple

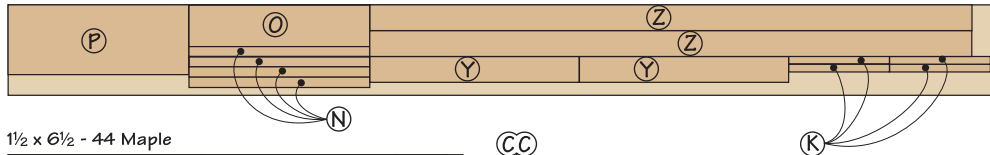

1 1/2 x 6 1/2 - 44 Maple

