

# ShopNotes®

Vol. 9

Issue 52

## Knock-Down Workbench

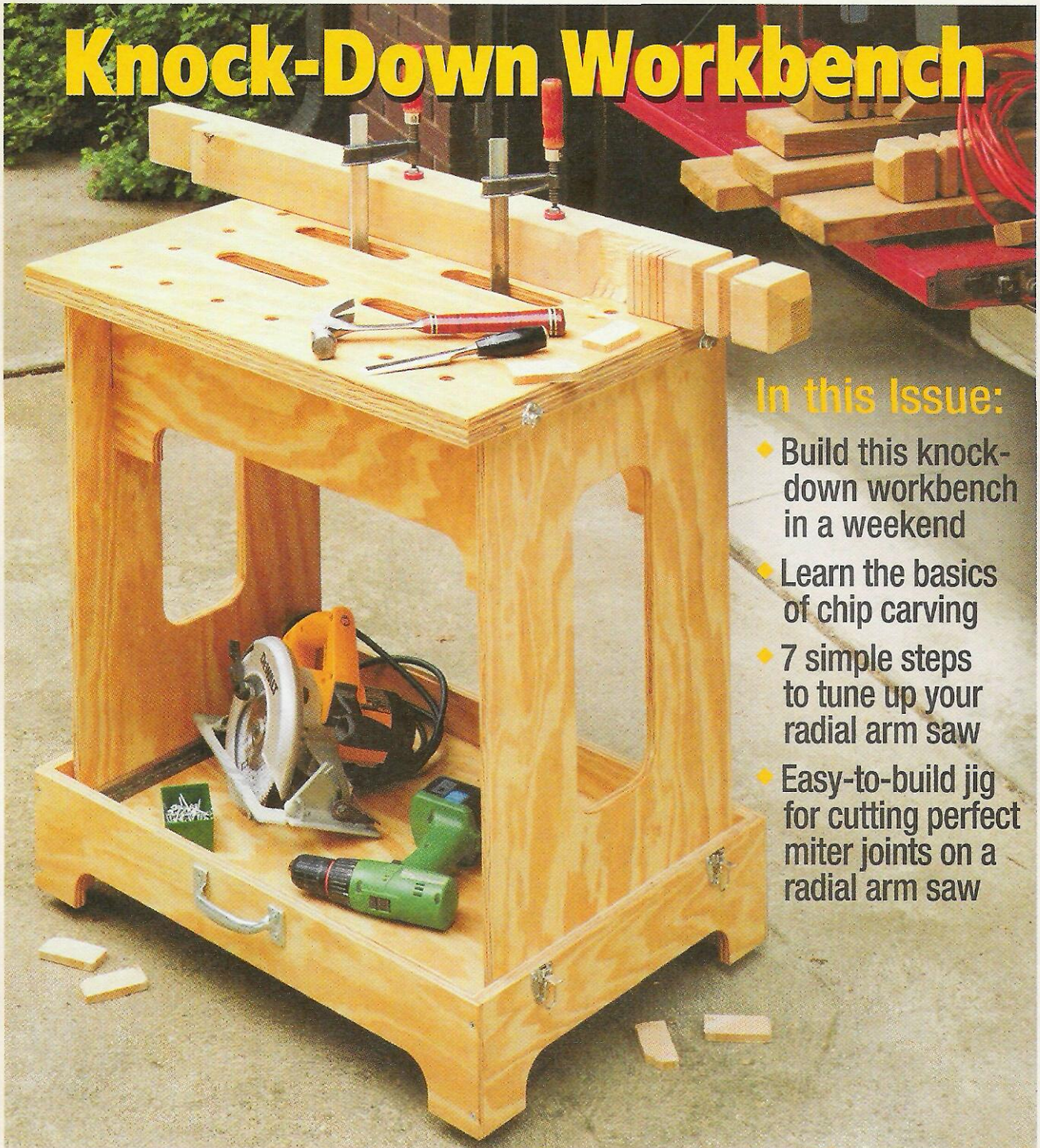

### In this Issue:

- ◆ Build this knock-down workbench in a weekend
- ◆ Learn the basics of chip carving
- ◆ 7 simple steps to tune up your radial arm saw
- ◆ Easy-to-build jig for cutting perfect miter joints on a radial arm saw





# ShopNotes®

Issue 52

July 2000

**PUBLISHER** Donald B. Peschke  
**EDITOR** Tim Robertson  
**ASSOCIATE EDITOR** Tom Begnal  
**ASSISTANT EDITOR** Bryan Nelson  
**ART DIRECTOR** Cary Christensen  
**SR. GRAPHIC DESIGNER** Kurt Schultz  
**SENIOR ILLUSTRATORS** Roger Reiland  
 Mark Higdon

#### CREATIVE RESOURCES

*Creative Director:* Ted Kralicek • *Project Developer:* Ken Munkel • *Senior Project Designer:* Kevin Boyle • *Project Coordinator:* Kent Welsh • *Shop Manager:* Steve Curtis • *Shop Craftsman:* Steve Johnson • *Senior Photographer:* Crayola England

#### SPECIAL PUBLICATIONS

*Executive Editor:* Douglas L. Hicks • *Sr. Graphic Designer:* Chris Glowacki • *Graphic Designers:* Vu Nguyen, April W. Janning, Stacey L. Krull • *Asst. Editors:* Joe Irwin, Craig Rueggeger, Joel A. Hess

#### CIRCULATION

*Sub. Serv. Dir.:* Sandy Baum • *New Bus. Dir.:* Glenda Battles • *Circ. Marketing Analyst:* Kris Schlemmer • *Creative Mgr.:* Melinda Haffner • *Renewal Mgr.:* Paige Rogers • *Sr. Graphic Designers:* Mark Hayes, Robin Dowdell • *Billing Mgr.:* Rebecca Cunningham • *Prom. Mgr.:* Rick Junkins • *New Bus. Mgr.:* Todd L. Bierle • *Asst. Sub. Mgr.:* Joy Krause

#### CORPORATE SERVICES

*Controller:* Robin Hutchinson • *Sr. Accountant:* Laura Thomas • *Accounts Payable:* Mary Schultz • *Accounts Receivable:* Margo Petrus • *Prod. Dir.:* George Chmielarz • *Electronic Pub. Dir.:* Douglas M. Lidster • *Network Admin.:* Cris Schwanebeck • *Pre-Press Image Specialists:* Troy Clark, Minnette Johnson • *New Media Manager:* Gordon C. Gaippe • *Multimedia Art Dir.:* Eugene Pedersen • *Technology Analyst:* Carol Schoeppler • *Web Site Product Specialist:* Adam Best • *Web Content Managers:* Terry Walker, David Briggs • *H. R. Asst.:* Kirsten Koele • *Facilities Mgr.:* Julia Fish • *Administrative Asst.:* Sherri Ribbey • *Receptionist:* Jeanne Johnson • *Mail Room Clerk:* Lou Webber

#### MAIL ORDER

*Operations Director:* Bob Baker • *Customer Service Manager:* Jennie Enos • *Warehouse Supr.:* Nancy Johnson • *Buyer:* Linda Jones • *Admin. Asst.:* Nancy Downey • *Tech. Rep.:* John Audette • *Cust. Serv. Reps.:* Anna Cox, Tammy Truckenbrod, Deborah Rich, April Revell, Jeanette Rankin • *Warehouse:* Sylvia Carey, Dan Spidle, Sheryl Knox

#### WOODSMITH STORE

*Manager:* Dave Larson • *Sales Staff:* Wendell Stone, Jim Barnett, Kathy Smith, Larry Morrison, Harold Cashman, Tim Rundell, Tim Thelen • *Office Manager:* Vicki Edwards

ShopNotes® (ISSN 1062-9696) is published bimonthly (Jan., March, May, July, Sept., Nov.) by August Home Publishing, 2200 Grand, Des Moines, IA 50312.

ShopNotes® is a registered trademark of August Home Publishing ©Copyright 2000 by August Home Publishing. All rights reserved.

**Subscriptions:** Single copy: \$4.95. One year subscription (6 issues), \$21.94. Canada/International add \$10 per year, U.S. funds.

**Periodicals Postage Paid** at Des Moines, IA and at additional mailing offices.

**Postmaster:** Send change of address to ShopNotes, P.O. Box 37103, Boone, IA 50037-2103.

**Subscription Questions?** Write to: ShopNotes Customer Service, P.O. Box 842, Des Moines, IA 50304-9961. Or call 1-800-333-5854, 8:00 am to 5:00 pm, Central Time, weekdays. FAX 515-283-0447

**E-Mail:** ShopNotes@shopnotes.com

**Internet:** http://www.shopnotes.com

PRINTED IN U.S.A.

# Cutoffs

When you think of a workbench, what often comes to mind is a classic, European-style bench. Chances are it has a sturdy base with lots of storage, a thick, hardwood slab for a top, and heavy-duty vises to clamp work in place.

There's no doubt about it. This type of bench is a great addition to a woodworking shop. But let's face it. It's big and heavy, so it sits in one place most of the time. (My workbench has been a permanent fixture in my shop for more years than I can remember.)

That's okay as long as I never have to move it around. But sometimes I'd like to be able to use a workbench outside the shop. Of course, dragging a massive bench out to the garage or back yard isn't very practical. So I usually set up a couple of sawhorses to use as a makeshift worksurface.

The only problem is there never seems to be a good way to clamp things in place. So I often end up balancing a workpiece precariously on the sawhorses, holding it with one hand, and making a less than perfect cut with the other.

What I needed was a small, portable workbench — one that had a lot of the same clamping features I'd come to appreciate on my full-size bench.

Besides being portable, there were a number of other requirements for the bench. It had to be inexpensive and easy to build. Plus I wanted a strong, stable bench that wouldn't tip over. Then I added one last item to my list. It had to "knock down" for storage to make it easy to carry around.

Well, it was starting to sound like

an awfully long "wish list," and at one point I began to wonder if it was even feasible. But when I mentioned the idea to our designers, they had lots of good suggestions to make it work.

**Knock-Down Workbench** – If you look at the front cover, you'll see how our knock-down workbench turned out. It's made from a single sheet of ¾" plywood which reduces the cost considerably. And the holes and slots peppered across the benchtop provide a number of different clamping options. Finally, it can be "knocked down" and stored in a box that you carry like a suitcase. (Think of it as a bench in a box.)

**Is it Sturdy?** That sounds great. But is a knock-down bench sturdy enough? To find out, we conducted a highly scientific test — two of the guys climbed on top and stood on it. Fortunately, the bench was as solid and sure-footed as a mountain goat.

**Saw Handle** – Another project in this issue that provided an interesting challenge is making a replacement handle for a carpenter's hand saw. I bought the saw at a second-hand store, and since the handle was in rough shape, I decided to make a new one.

I wanted it to look like a traditional saw handle with a graceful, curved shape. That sounded simple enough. I'd just cut a chunk of wood to shape and stick in the saw blade.

But there was a catch. The blade fit into a very thin slot in the old handle that must have been cut by a specialized tool (one I certainly didn't have). So as it turns out, I took a rather unorthodox approach to make a traditional looking handle.

*A bench in a box . . . and a new twist to a traditional hand tool. Two simple solutions from our shop.*

*Tim*



# Contents

## Features

### Adjustable Miter Jig \_\_\_\_\_ 6

This shop-made jig makes it easy to cut perfect 45° miters on a radial arm saw. It features a short and a long pair of fences for different length workpieces, an adjustable stop for consistent results, and a hold-down to make cuts safely.



Adjustable Miter Jig page 6

### Radial Arm Saw Tune-Up \_\_\_\_\_ 12

All it takes to improve the performance of your radial arm saw is a simple tune-up. We show you seven quick steps to producing smooth, accurate cuts.

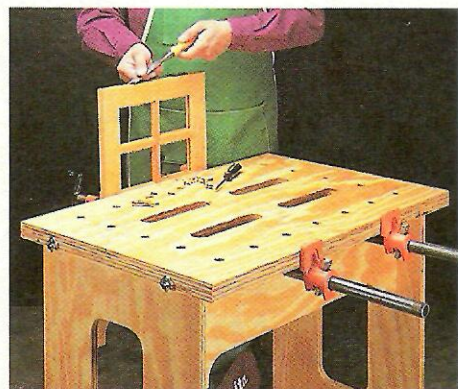

Knock-Down Workbench page 16

### Knock-Down Workbench \_\_\_\_\_ 16

Whether you use this plywood bench to build a woodworking project or a deck in the back yard, its three different clamping options are sure to come in handy. Once you complete a job, it only takes a minute to "knock down" the bench for storage.

### Cherry Saw Handle \_\_\_\_\_ 24

The graceful curves and the carved wheat pattern of this cherry saw handle resemble a traditional design. But to simplify the construction, we've taken a unique approach to fitting the saw blade into the handle.

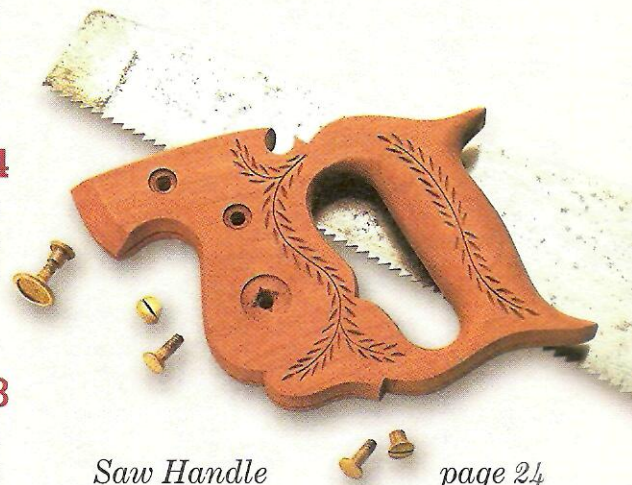

Saw Handle page 24

### Chip Carving \_\_\_\_\_ 28

You can add an old-fashioned accent to your saw handle by using a chip carving knife to make stems of wheat. With a little bit of practice and a few helpful hints, you'll be chip carving like a pro in no time.

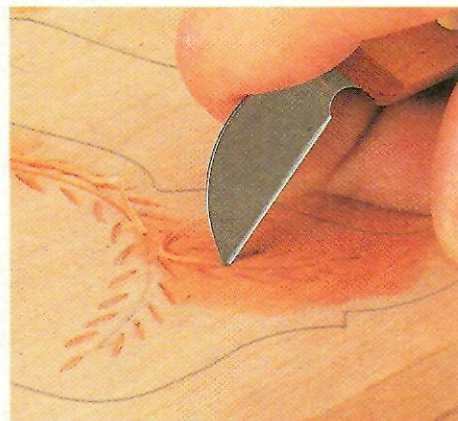

Chip Carving page 28

## Departments

### Readers' Tips \_\_\_\_\_ 4

Our readers offer their own shop-tested tips dealing with some of the most common woodworking problems.

### Sources \_\_\_\_\_ 31

Mail-order sources and supplies to help you build the projects featured in this issue.



# Readers' Tips

## Knock-Down Sawhorses

■ A set of sawhorses always comes in handy — until you put them away. Then they're a nuisance. The legs splay out, they're hard to stack, and they take up valuable space.

So recently, I built a pair of sawhorses that “knock down” for storage. Besides saving space, these sawhorses can be assembled (or taken apart) in just a few seconds.

If you look at the drawing at right, it's easy to see how this works. Each sawhorse consists of a long *stretcher* that fits down into a notch in two A-shaped *supports*. (I used 1x4 pine.)

To prevent the sawhorse from racking, there are four small *cleats* near each end of the stretcher (two on each side). These cleats are spaced far enough apart to form a channel that fits down over the supports and “locks” the stretcher in place. (You can see this interlocking connection in the photo above.)

Once the cleats are glued and screwed in place, it's just a matter of making the two supports. Each support consists of two angled *legs* that are held together with four *braces* (a long and short brace on each side).

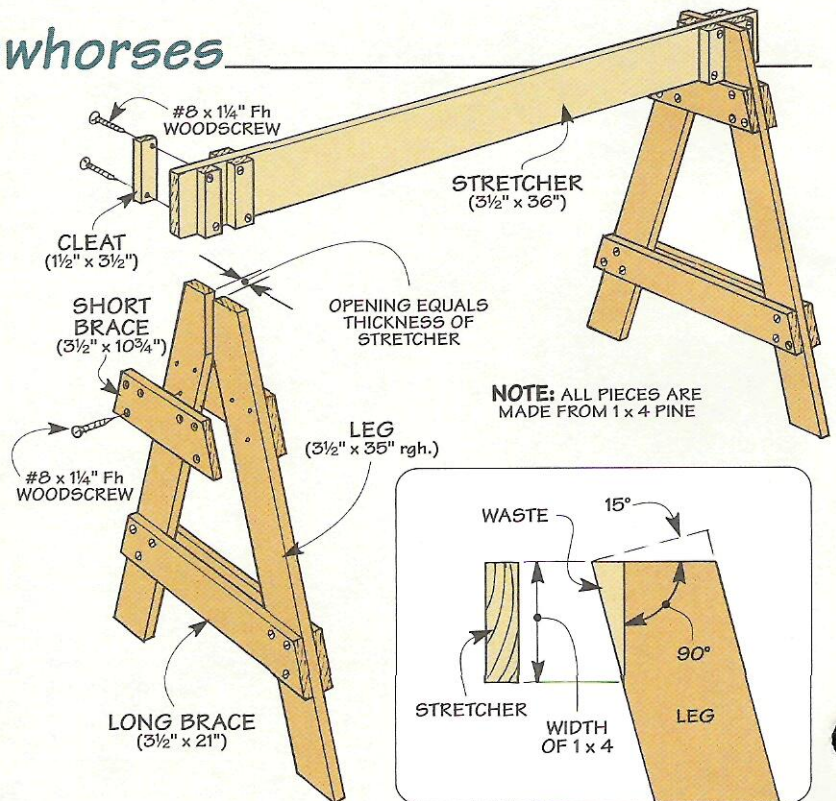

Both ends of the legs and braces are mitered at a 15° angle. Also, to form the notch that accepts the stretcher, you'll need to trim the *top inside* corner of each leg at an angle, as shown in the detail above.

An easy way to lay out this angle is

to set a square on the angled end of the leg and mark a line that's equal in length to the width of the stretcher. After trimming off the waste, just glue and screw the supports together.

W. R. Richardson  
Great Falls, Montana

## Quick Tips



▲ Here's a simple pencil tray for your shop. Adolph Peschke of Des Moines, IA cuts a scrap PVC pipe down its length and glues the halves together.



▲ At a glance, it's difficult to tell if a caster is locked or not. So P. A. Jones of Seattle, WA paints the “lock” lever red and the “release” lever green.

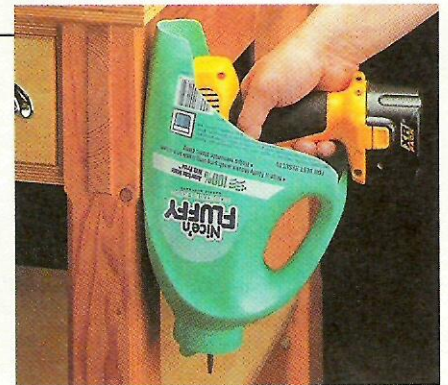

▲ To make a “holster” for a cordless drill, Terrence McGinty of Suttons Bay, MI removes the bottom from a plastic bottle and screws the container to his bench.



## Installing Hinges

■ Installing the hinges on a small box used to be a hassle. I could attach one leaf of the hinge to the box easily enough. But locating the mounting holes for the other leaf on the *bottom* of the lid was a pain.

One solution is to use hot glue to temporarily fasten the hinge to the lid. The only problem is the glue often dries before you can align the lid on the box. So I use a simple trick to quickly and accurately position the lid *and* to lay out the holes for the hinge.

Start by screwing one leaf of the hinge to the box. Then use hot glue to attach small scrap blocks to the front and sides of the lid, as shown in the drawing. Note: These scrap blocks should stick down past the lid so they fit snugly around the box.

After shimming the leaf of the hinge with a piece of cardboard, apply

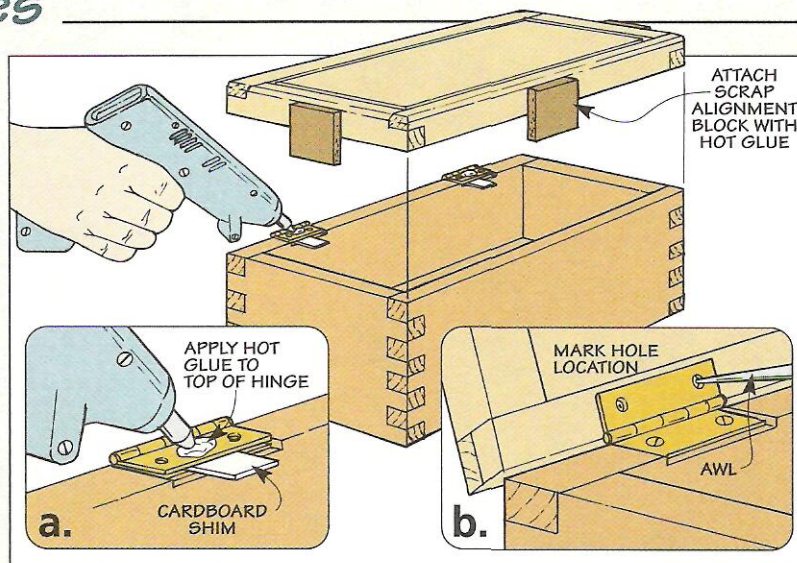

a dab of hot glue (detail 'a'). Then quickly fit the blocks on the lid down over the box. When you open the lid, the leaf of the hinge is stuck in its proper location, so it's easy to mark

the mounting holes (detail 'b'). Note: After removing the scrap blocks, sand any excess glue off the lid.

*Joe B. Drane  
Yigo, Guam*

## Plastic Runner



■ Many of the jigs used on a table saw have a runner that slides in the miter gauge slot. Typically, these runners are made of hardwood. But recently I started using another type of material I like even better — plastic.

One nice thing about a plastic runner (like the one shown at left) is it won't swell or shrink with changes in humidity. So it slides smoothly without binding. Plus, plastic is readily available. As you can see in the photo at right, I just cut a narrow strip from a plastic cutting board.

*Jerry Long  
Silver Lake, Wisconsin*

## Finishing Fix

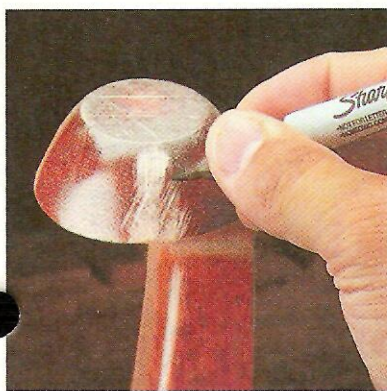

■ It's easy to repair a small nick or a scratch in a piece of furniture that's already had a finish applied. All it takes is a brown (or black) permanent marker.

After choosing a marker that most closely matches the color of the wood, scribble the marker across the nick and wipe off the excess. Note: There's no need to touch up the finish.

*George Reid  
Dayton, Ohio*

## Send in Your Shop Tips

If you have a unique shop tip, we'd like to consider featuring it in one or more of our print or electronic publications.

We'll pay up to \$200 for a tip we publish. Just write down the tip and mail it to *ShopNotes*, Attn.: Readers' Tips, 2200 Grand Ave., Des Moines, IA 50312. Or FAX it to 515-282-6741, or send us an e-mail at [shopnotes@shopnotes.com](mailto:shopnotes@shopnotes.com). Please include your name, address and daytime phone number in case we have any questions.

## FREE Online Tips

If you'd like even more woodworking tips, the solution is simple. Just visit us at our website and sign up to receive a free tip via email every week.

[www.ShopNotes.com](http://www.ShopNotes.com)



# Radial Arm Saw Miter Jig



*It's easy to cut perfect 45° miter joints on a radial arm saw. All you need is a simple jig.*

**T**rying to cut a miter joint on a radial arm saw can be a frustrating experience. As you swing the arm first to one side and then the other to cut each miter, it may not always return to a perfect 45° setting. Unfortunately, you may not even notice that the cut is “off” until it’s too late.

So to make it easy to cut tight-fitting miter joints quickly and accurately, I made a simple jig that clamps to the table of the radial arm saw. (See photo above.)

**Fences** – This jig has two fences that are used to position a workpiece at 45° to the saw blade. So instead of swinging the arm to the side, the idea is to leave it set at 90°. This way, as you pull the head of the saw across the workpiece, the blade trims the end at a perfect 45° angle.

The fences are designed to slide back and forth. The fence that’s in use is moved all the way forward to support the workpiece close to the blade. The other fence is slid back to provide clearance for the end of the workpiece.

**Accessories** – In addition to the fences, there are two accessories that help simplify cutting a miter joint. A *stop block* that attaches to either fence ensures that each pair of pieces is mitered to the same length. And a *hold-down* keeps your hands safely away from the blade during a cut.

**Auxiliary Fence** – Before you build the jig, there’s one thing to take care of first. To prevent small cutoff pieces from getting jammed against the fence and thrown back by the saw blade, it’s important to install an auxiliary fence in your radial arm saw. As you can see in Figure 1, the auxiliary fence I used is a piece of 3/4"-thick pine with a long notch that provides clearance for the cutoff pieces.

## BASE

The base of the miter jig acts as a mounting platform for the two fences. Plus it has a couple of T-shaped slots that provide a way to attach the hold-down.

**Two Layers** – To make it easy to form the T-slots, the base is made up of two layers of material: a *bottom* piece made of 3/4" MDF and a 1/4" hardboard *top* (Figure 1). One part of the T-slot will be cut in each piece.

**Size** – But first, you’ll need to determine the size of the base. I wanted it to be flush with the *left end* and *front edge* of the saw table. (It’s easier to clamp it to the table that way.) So I made the base twice as long as the distance from the blade to the end of the table (Figure 1). As for width, it equals the distance from the fence to the front edge.

**Bottom** – At this point, you can cut the *bottom* (A) of the base to size. Then, to form the lower part of the T-slot, you’ll need to cut two stopped dadoes. These dadoes accept the head of a toilet bolt used to attach the hold-down.

So what’s the purpose in cutting *stopped* dadoes? Why not extend them all the way across? Because the hold-down only needs to be adjustable toward the outer part of the base. As a result, the T-slots run about halfway across.

A simple way to cut these dadoes is to use a hand-held

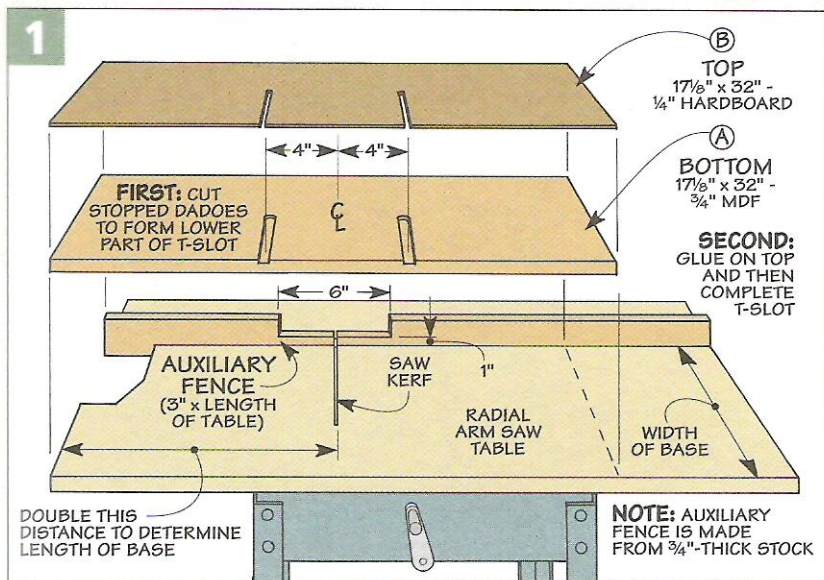



router and a 1/2" straight bit. Start by clamping a scrap fence to the workpiece to guide the base of the router (Figures 2 and 2a). It's also a good idea to clamp a stop block to the workpiece to establish the end of the dado. Now adjust the depth of cut, turn on the router, and make a pass from left to right until the router base contacts the stop block.

Since the dado is 5/8" wide, you'll need to reposition the fence and make a second pass to remove the rest of the waste material. Then repeat the process to cut the second dado.

**Top** - With the dados complete, you can add the hardboard top (B). It's best to start with an oversize piece (about 1/4" all the way around). Then after gluing it on with contact cement, trim the edges flush with a hand-held router and flush trim bit.

Now it's time to complete the T-slot by routing a narrow, stopped dado in the top (Figure 2b). Here again, I used the same basic routing procedure. Only this time, the slot is

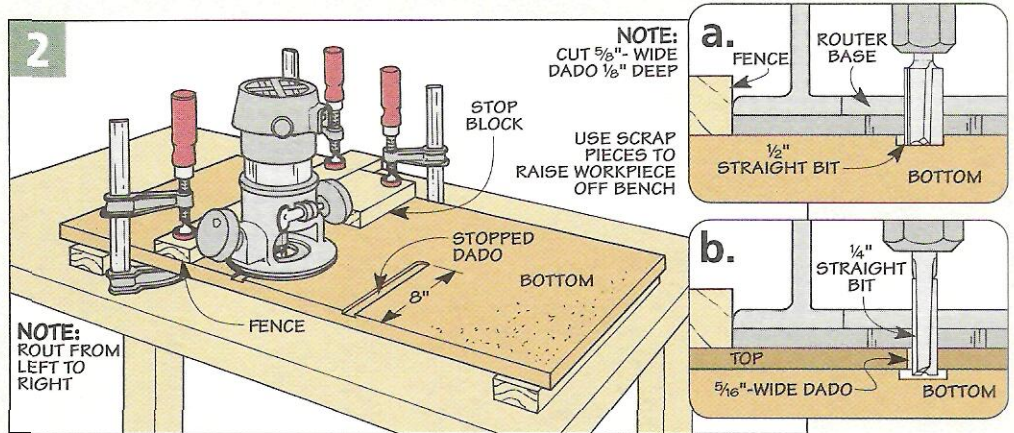

5/16" wide, so I used a 1/4" straight bit and made a couple of passes to center the dado over the one below.

**Guides** - The next step is to add two angled guides (C) to the base (Figure 3). These are narrow strips of hardwood that position the fences at a 45° angle to the blade. In use, the fences fit over the guides which allows you to slide them back and forth.

To ensure accurate results, the guides must be at a 45° angle to the back edge of the base. So what's the

best way to lay out the angled lines used to position the guides? A little bit of geometry is just the ticket.

The idea is to lay out a *right isosceles* triangle. If you need a refresher, that's a triangle that has one 90° angle and two equal sides. This means that the other two angles of the triangle *must* be 45°.

So to lay out the angled lines, mark a point centered on the length of the base and measure the distance to one end. This is one side of the triangle. (It's shown as dimension 'A' in Figure 3.) Now lay out the second side and mark another point. Connecting the two points creates the third side of the triangle *and* the two 45° angles.

**Attach Guides** - At this point, you can glue and screw the runners along the layout lines. Just be sure they don't slip out of alignment as you tighten the screws.

**T-Nuts** - There's one last thing to do to complete the base. That's to install a pair of T-nuts in the bottom of the base. Later, these T-nuts accept a threaded knob that's used to clamp the fences to the guides.

The T-nuts are centered on the length and width of the guides. But since they're installed in the bottom of the base, the trick is locating the centerpoints of the counterbored shank holes for the T-nuts.

To do this, start by drilling a small pilot hole in each guide (Figures 4 and 4a). Then flip the base over and use the point where the bit cut through as the centerpoint of the counterbore (Figure 4b). Now simply drill the shank hole (Figure 4c) and install a T-nut.

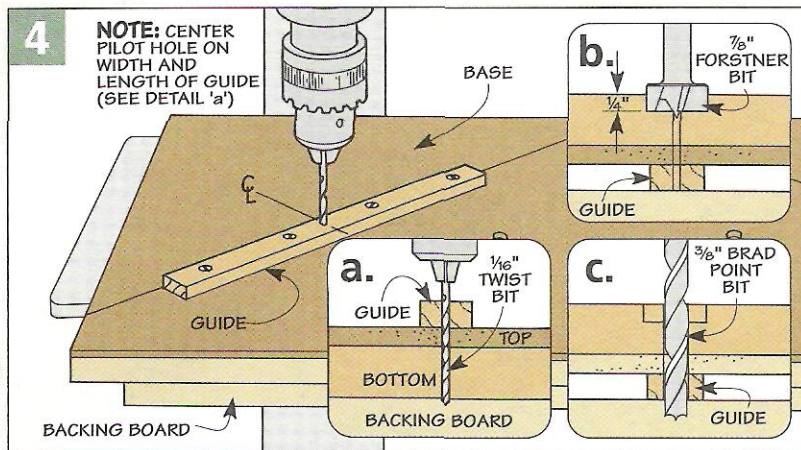
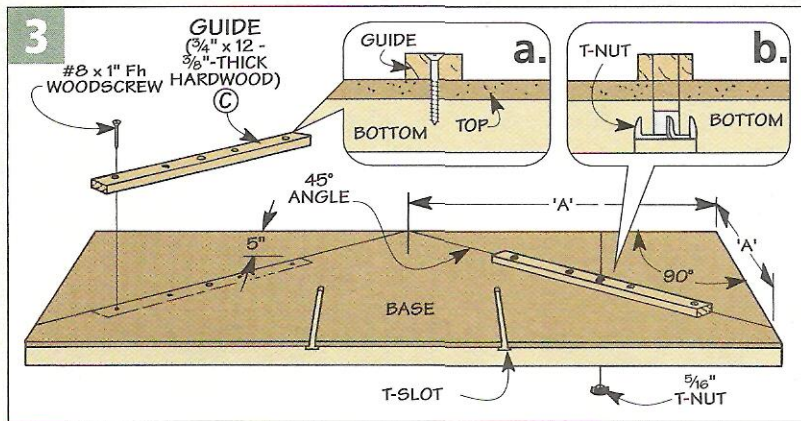



# Fence System

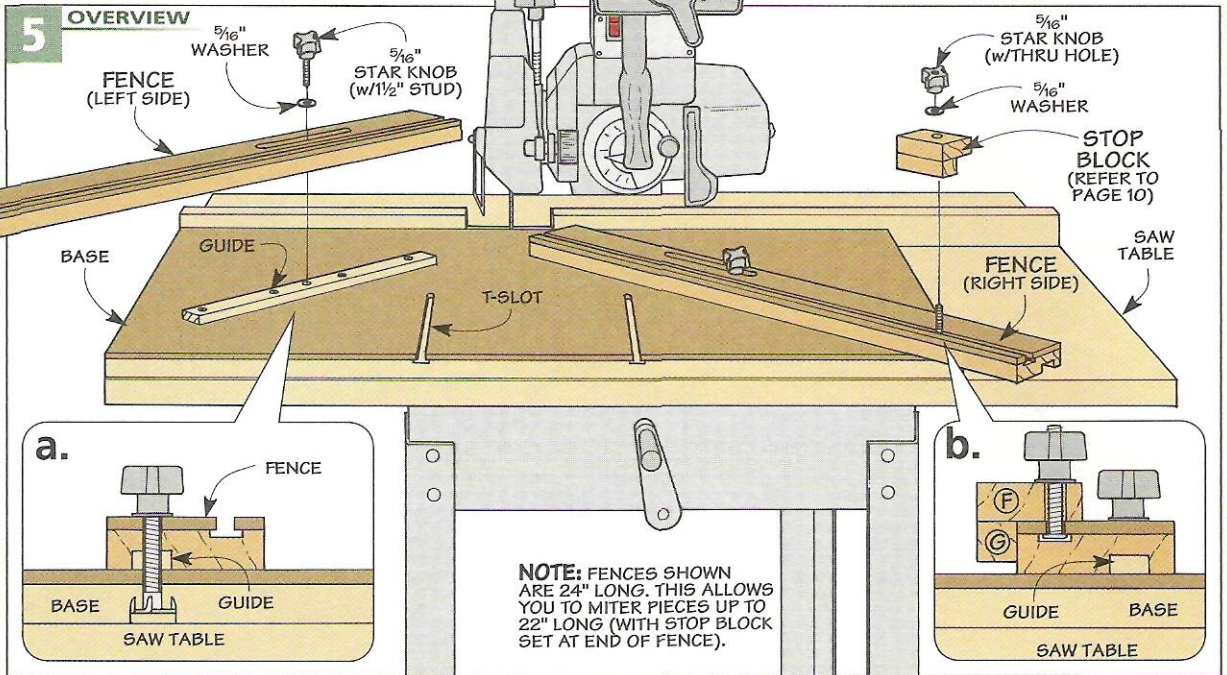

## Hardware

- (8) #8 x 1" Fh Wood screws
- (2) 5/16" T-Nuts (w/prongs)
- (4) 5/16" Washers
- (2) 5/16" Star Knobs (w/1/2" stud)
- (2) 5/16" Star Knobs (w/thru hole)
- (2) 5/16" x 2" Toilet Bolts

The heart of this miter jig is a simple fence system. It consists of a pair of adjustable fences that are used to position a workpiece at a perfect 45° angle to the saw blade.

**Fence Length** – There’s nothing critical about the length of the fences. The two fences shown in Figure 5 are 24" long, so they provide plenty of support for most work. But when determining the length of the fences,

there is one thing to keep in mind.

To cut pairs of mitered pieces to identical length, there’s a stop block that slides along a T-slot in the fence. Setting the stop block all the way at the end of the T-slot allows you to miter pieces up to 22" long. If you plan to work with longer pieces, it’s a good idea to make a pair of extra-long fences as shown in the photo on page 9.

**Two Layers** – Regardless of their length, each fence is made up of two different layers of material (Figure 6). A 3/4"-thick hardwood *body* fits over the guides on the base. (I used maple.) And there’s a *top face* made of 1/4" hardboard. As with the base, this double layer type of construction will make it easy to form the T-shaped slots in the fence.

**Body** – I began by making the *body* of each fence. It’s worth taking a little extra time and being a bit picky when selecting wood for the body. To prevent the fence from warping or twisting, be sure to use a piece of straight-grained stock that’s free of knots or other defects.

Once you’ve selected the lumber, the first step is to rip enough stock to width to make the desired number of pieces. Then simply crosscut the pieces to final length to make the *body* (D) of each fence.

**T-Slot** – Now you can turn your attention to the T-slot. The first part of this slot is formed by cutting a wide, shallow groove in the body of the fence (Figure 6a). This groove accepts the head of a toilet bolt that guides the stop block in the slot.

Before cutting the second part of

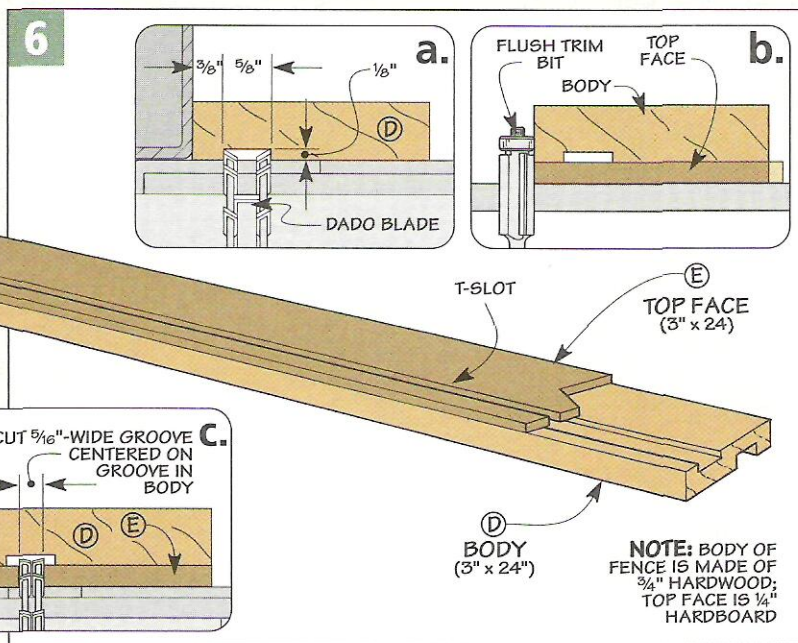

**NOTE:** BODY OF FENCE IS MADE OF 3/4" HARDWOOD; TOP FACE IS 1/4" HARDBOARD



the T-slot, you'll need to add the hardboard top face (E). Eventually, it ends up the same size as the body. But it's best to start with a piece that's slightly oversize (about 1/4" all the way around). Then, after gluing it onto the body of the fence, you can trim the overhanging edges flush.

Here again, it only takes a minute to remove the waste. Just mount a flush trim bit in the router table, and adjust the height of the bit so the bearing rides against the body of the fence (Figure 6b). Then rout all four sides to produce a clean, crisp edge all the way around.

To complete the T-slot, it's just a matter of cutting a narrow groove in the top face that's centered over the wide groove underneath (Figure 6c). This groove provides clearance for the shank of the toilet bolt.

**Wide Groove** – In addition to the T-slot in the top of each fence, there's also a wide groove in the bottom. As you can see in Figure 5, the groove fits over the hardwood guides that were installed earlier in the base. These guides are like a "key" that automatically positions the fence at 45° to the saw blade.

Another purpose of the groove is to allow the fence to slide forward or back on the guide. For example, in

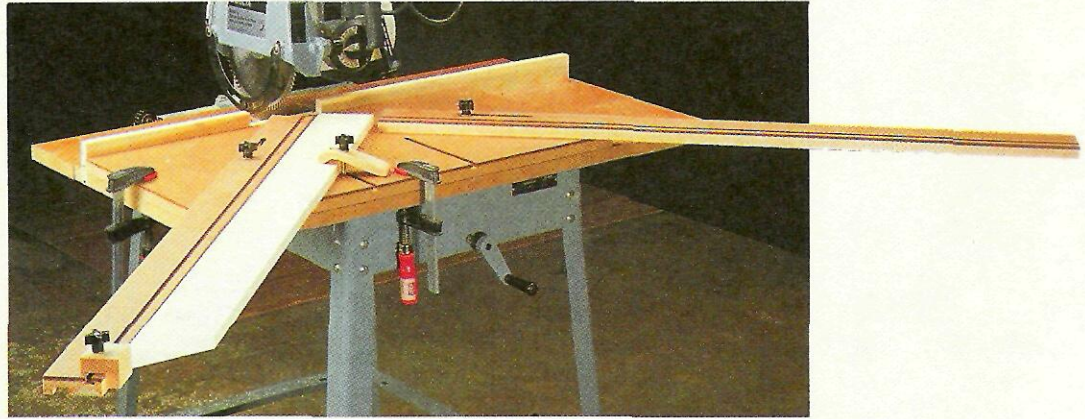

▲ **Long Fences.** As an option, you may want to build a pair of 48"-long fences to use when mitering extra-long workpieces. With the stop block set at the end of the fence, you can cut pieces up to 46" long.

the photo above, the left fence is moved all the way forward to provide support for the workpiece up close to the saw blade. But to allow the end of the workpiece to extend past the fence on the right, that fence is slid all the way back.

Even though the fences move back and forth, you don't want any extra side-to-side "play." (That could change the 45° angle of the fence.) So when cutting the groove, the goal is a snug fit that still allows the fence to slide smoothly on the guides.

An easy way to accomplish that is shown in Figures 7 and 7a. The idea is to mount a 1/2" dado blade in the

table saw and make several passes to "sneak up" on the perfect fit. Just be sure to check the fit frequently as you work.

**Adjustment Slot** – Once you're satisfied with the fit, the next step is to cut a long adjustment slot in each fence. As you can see in Figure 5, this slot provides clearance for a plastic knob with a threaded shank that's used to lock the fence.

If you look at Figure 5a, you can see that the knobs thread into the T-nuts that were installed earlier in the base. As you recall, these T-nuts are centered on the width of the guides. This means the adjustment slot also needs to be centered on the groove that fits over the guides.

A quick way to do this is to clamp a scrap piece to the drill press table and use it to position the fence (Figures 8 and 8a). Then place a scrap block under the fence to prevent chipout and drill a series of overlapping holes to form the slots. All it takes to clean up the slot is to pare off the remaining waste with a chisel and then file the edges smooth.

**Install Fences** – Now just install the fences and thread in the knobs to hold them in place.

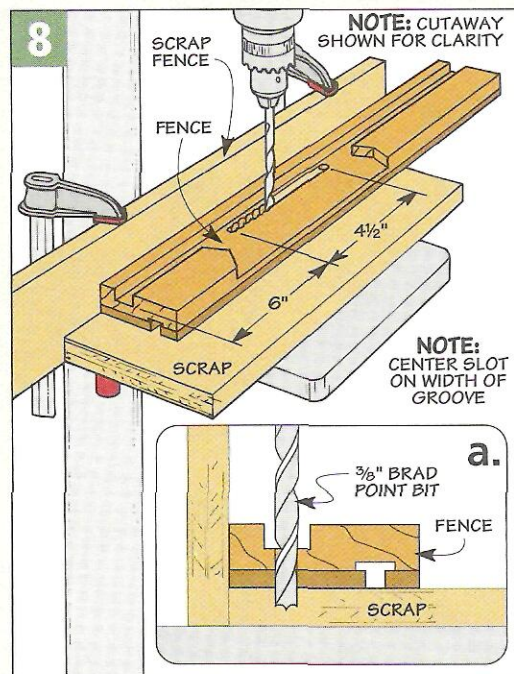
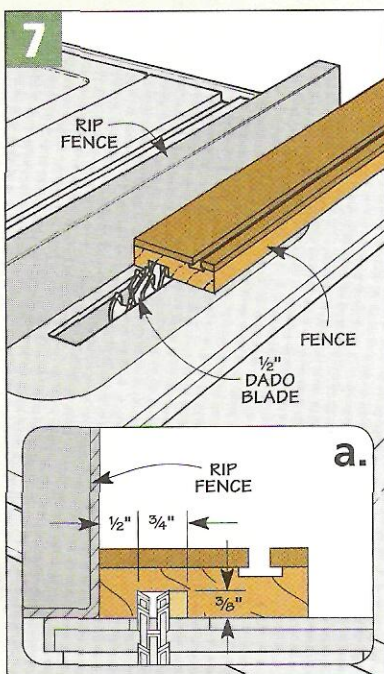



# Accessories

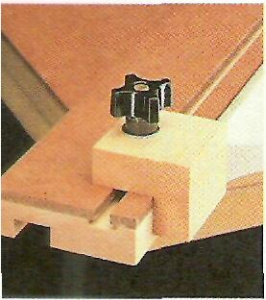

▲ **Stop Block.**  
An adjustable stop block provides a quick, accurate way to miter pieces to identical lengths.



▲ **Hold-Down.**  
For safety, this simple hold-down clamps work securely against the base of the jig.

To ensure safe, accurate cuts when using the miter jig, I added two simple accessories: a *stop block* and a *hold-down*. (See photos in margin.)

## STOP BLOCK

There's more to cutting perfect miter joints than establishing the correct angle. To end up with a tight-fitting joint, *opposite* pieces (the sides and top/bottom of a picture frame for instance) must be identical in length.

That's where the stop block comes in. To produce consistent results, you simply lock the stop block at the desired distance from the blade, butt the end of the workpiece against it, and make the cut. Note: I only made one stop block and then used it on both of the fences.

**L-Shaped Block** – As you can see in Figure 9, the stop block is just an L-shaped block that's made up of two pieces of  $\frac{3}{4}$ "-thick hardwood. A *sliding block* (F) with a hole drilled near the edge accepts the shank of the toilet bolt. And the *stop* (G) is the part that the end of the workpiece actually butts up against.

After gluing up the stop block, just slip the end of the toilet bolt through the hole and slide the head into the T-slot. Tightening a knob on the end

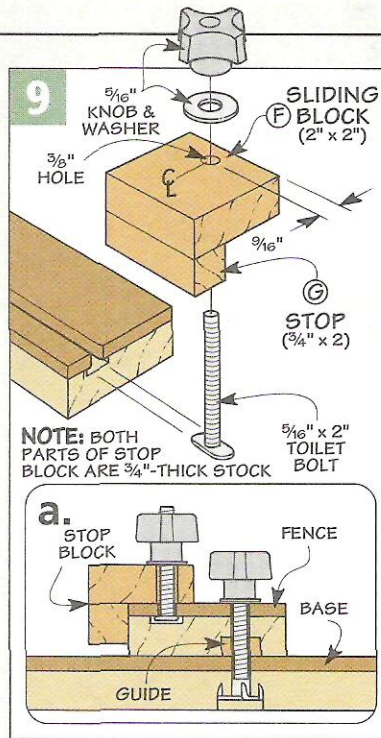

of the bolt pinches the stop block against the fence and locks it in place.

## HOLD-DOWN

The second accessory for the miter jig is a hold-down that's used to clamp work securely in place. This way, there's no need to worry about getting your hands too close to the saw blade, especially when mitering short pieces.

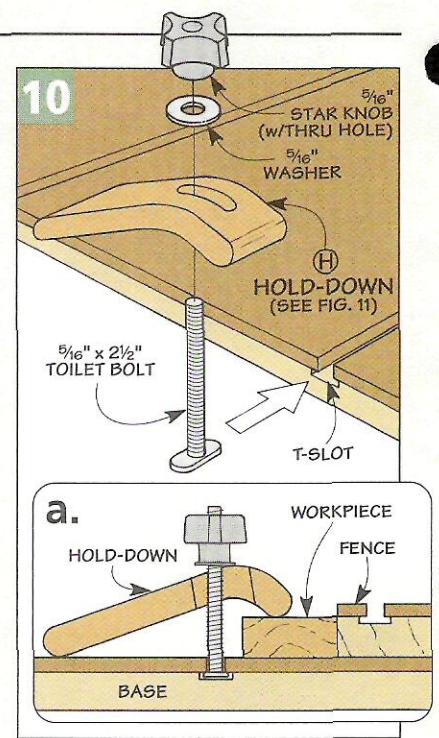

To accommodate workpieces of different lengths, the hold-down slides along the T-slots in the base. (Here again, I only made one hold-down and used it in both slots.)

The unusual thing about this hold-down is its angled shape. If you look at the lower photo in the margin, you'll see that the long, straight end of the hold-down rests against the base of the jig, and the short, angled end applies pressure against the workpiece. This clamping pressure is produced by tightening a knob on the end of a toilet bolt that slides in the T-slot (Figures 10 and 10a).

**Glue Up Blank** – As you can see in Figure 11, the *hold-down* (H) starts off as a  $1\frac{1}{2}$ "-square blank. (I glued up two pieces of  $\frac{3}{4}$ "-thick maple.)

There are two ways to go about transferring the basic shape of the hold-down to the blank. You can either enlarge the pattern in Figure 11 by 150% and use a spray-mount adhesive to stick it to the blank. Or just lay out the shape on the blank.

To accept the toilet bolt, you'll need to drill a series of holes to make a slot in the blank. Then just use a band saw to cut the hold-down to shape and sand it smooth.

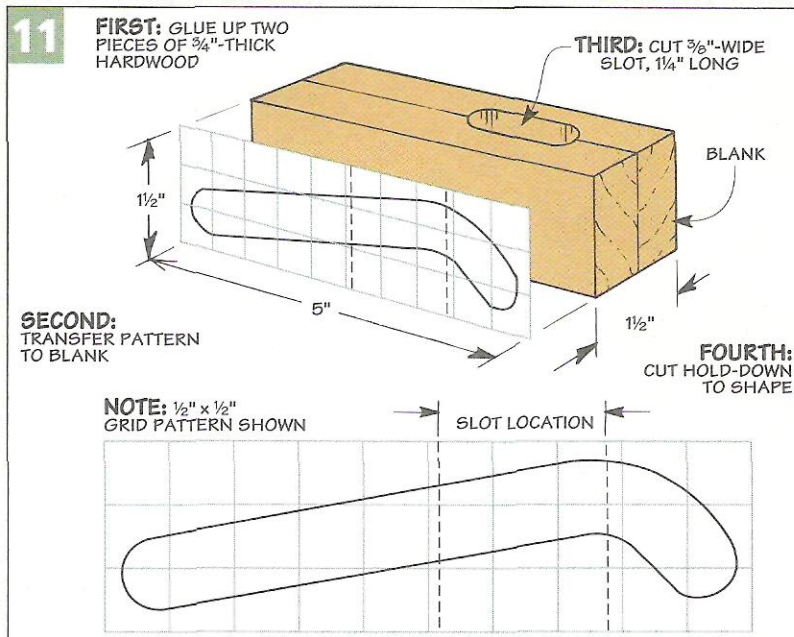



# Setup

It only takes a minute to set up the miter jig on the radial arm saw.

**Dowels** – That’s because there are two dowels in the base of the jig that automatically position it on the saw table. As you can see in Figures 12 and 12a, these dowels fit down into holes in the saw table.

To determine the location of the dowels, set the jig on the table so it butts against the auxiliary fence. Also, be sure to check its location from side to side. The goal is to have the saw blade centered on the *length* of the jig. This way, the blade won’t accidentally cut into the fences when they’re slid all the way forward.

Once the jig is positioned prop-

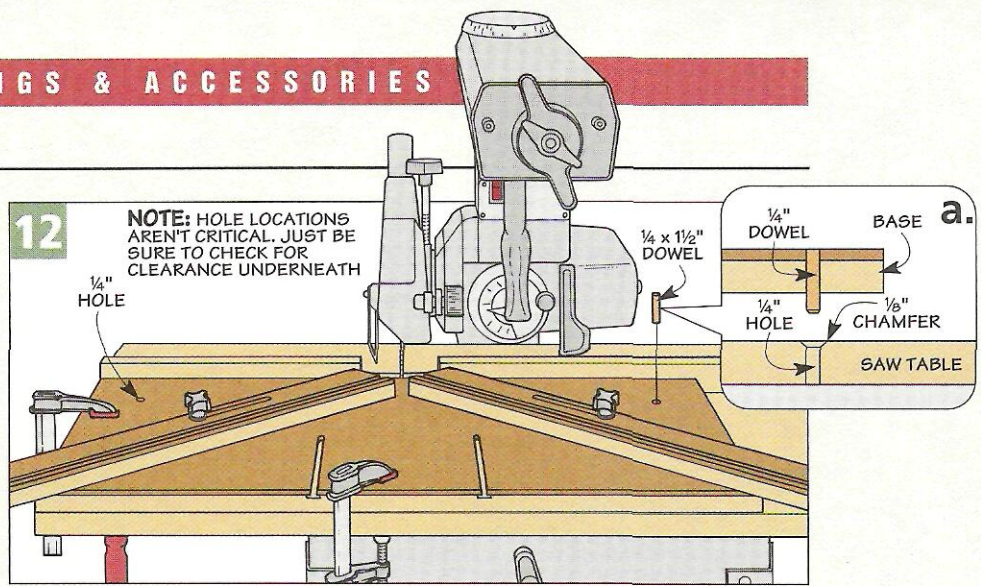

erly, it’s just a matter of drilling a couple of holes through the base and the saw table. Before installing the dowels, it’s a good idea to chamfer the rim of the hole in the base. This

will make it easy to fit the dowels in the holes when setting up the jig. After sanding a slight chamfer on the end of each dowel, it’s simply glued into the hole in the base.

# Using the Jig

Once the jig is clamped in place, you’re ready to miter the frame pieces.

**Rough Length** – I start by cross-cutting all the pieces to rough length. If they’re less than 4 1/2" wide, you can cut them with the jig in place. Just install the original radial arm saw fence (the one without the notch), slide both fences on the jig back, and cut the pieces. Note: For wider pieces, you’ll need to remove the jig.

**Label Pieces** – Next, to avoid confusion, I label the sides ‘A’ and the top/bottom pieces ‘B,’ as in the drawing at right. But even with the pieces clearly marked, it’s still possible to get them mixed up. So it helps

to follow a specific cutting sequence.

**Cutting Sequence** – The first step is to miter one end of *all* the pieces. (These are the ends marked with an ‘X’ in the drawing at right.) All of these cuts are made with the workpieces held against the *right* fence. So slide this fence forward and the left fence back (Figure 13).

Then set the first ‘A’ piece against the fence, tighten the hold-down, and make the cut. Note: Locking the stop block against the end of the workpiece provides a quick way to position the other ‘A’ piece. Then repeat this process for the ‘B’ pieces.

After cutting the miters on one

end of each piece, the next step is to miter the opposite ends. These cuts are made with the workpiece against the *left* fence, as shown in Figure 14.

Start by setting the stop block the desired distance from the blade. Then butt the end of the piece against the stop block, tighten the hold-down, and make the cut. Note: Unless you’re working with a square frame, reposition the stop block to cut the second pair of pieces.

▲ Labeling the frame pieces makes it easy to keep track of things when cutting the miter joints.

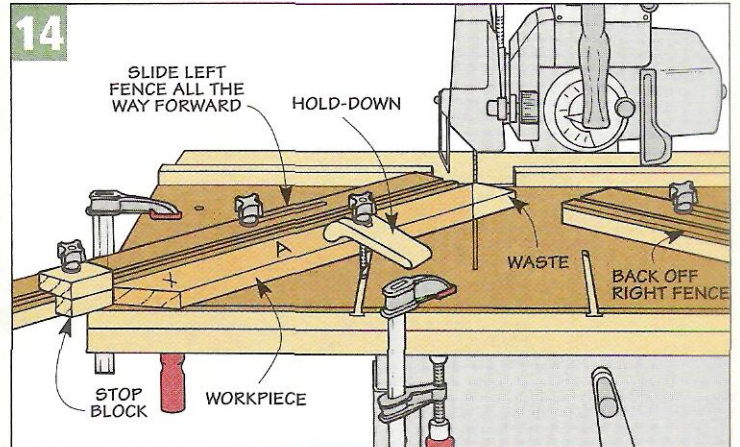
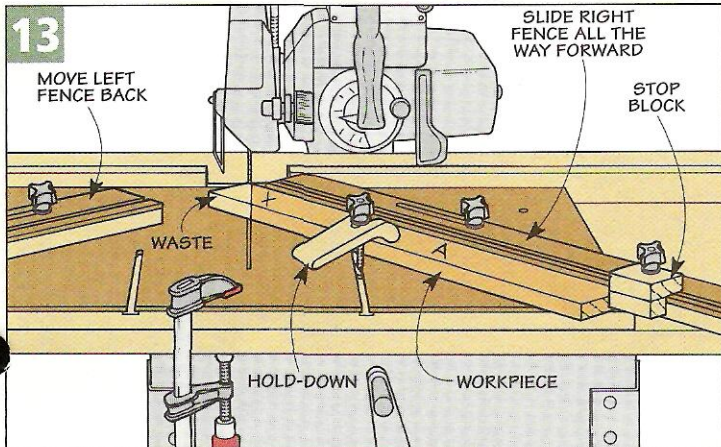
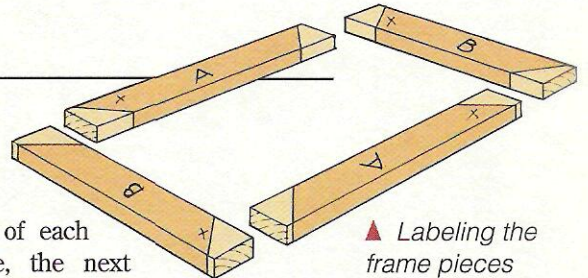



# 7 Step

## Radial Arm Saw Tune-Up

*All it takes to keep a radial arm saw running in top condition is a little periodic maintenance and a simple tune-up.*

There's no question that a radial arm saw is a versatile tool. You can use it for everything from cross-cutting or ripping a board to cutting miters and bevels.

But there's a trade-off for this versatility. If the saw isn't adjusted properly, the result is a less than perfect cut. Perhaps the end of a board isn't square, or the saw blade leaves a rough, burned edge. Worse yet, the

blade may "grab" and race through the workpiece under its own power. That's downright scary.

**Tune-Up** – Fortunately, all it takes to produce a smooth, accurate cut on a radial arm saw is a simple tune-up. This doesn't require any specialized tools. And all the adjustments can be boiled down to *seven* basic steps, so the entire process usually only takes about a half hour.

**How it Works** – Before you get started, it's worth taking a minute to look at the drawing below to see how the parts of the saw work together. A long *arm* supports the *head* (blade and motor) of the saw. The head is held in an adjustable *yoke* that allows you to pivot the blade 90° (for ripping lumber) or tilt it at an angle (to make beveled cuts).

To crosscut a board, the yoke is mounted on a sliding *carriage*. When you pull the head of the saw forward, the carriage is guided by a set of four *roller bearings* that ride on a *track* housed inside the arm.

To provide rigid support for the arm, it's attached to a cylindrical *column* that can be raised or lowered to adjust the depth of cut. By releasing a lock mechanism and swinging the arm to one side or the other, it allows you to make angled cuts. Or return the arm to a 90° setting to square up the end of a board.

**Clean Saw** – Needless to say, each of these parts needs to operate smoothly to ensure good results. One of the easiest (and most effective) things you can do to accomplish this is to clean up the saw by giving it a good "once-over."

Start by using an air compressor (or shop vacuum) to remove the loose dust. Then wipe off any caked-on dust with a rag dampened with mineral spirits. Pay special attention to the column, roller bearings, and the track.

If they're covered with dirt and grime, it's much more difficult to make accurate adjustments.

**Lubrication** – After cleaning off the gunk, I make it a point to lubricate the moving parts of the saw. Note: The lubrication points are shown in the drawing at left.

Since a radial arm saw produces quite a bit of dust, it's best to avoid using an oily lubricant. Dust sticks to it like glue and makes a gooey mess. So I use a "dry" spray lubricant that doesn't attract dust. (For more information about the type of dry lubricant I use, refer to page 31.)

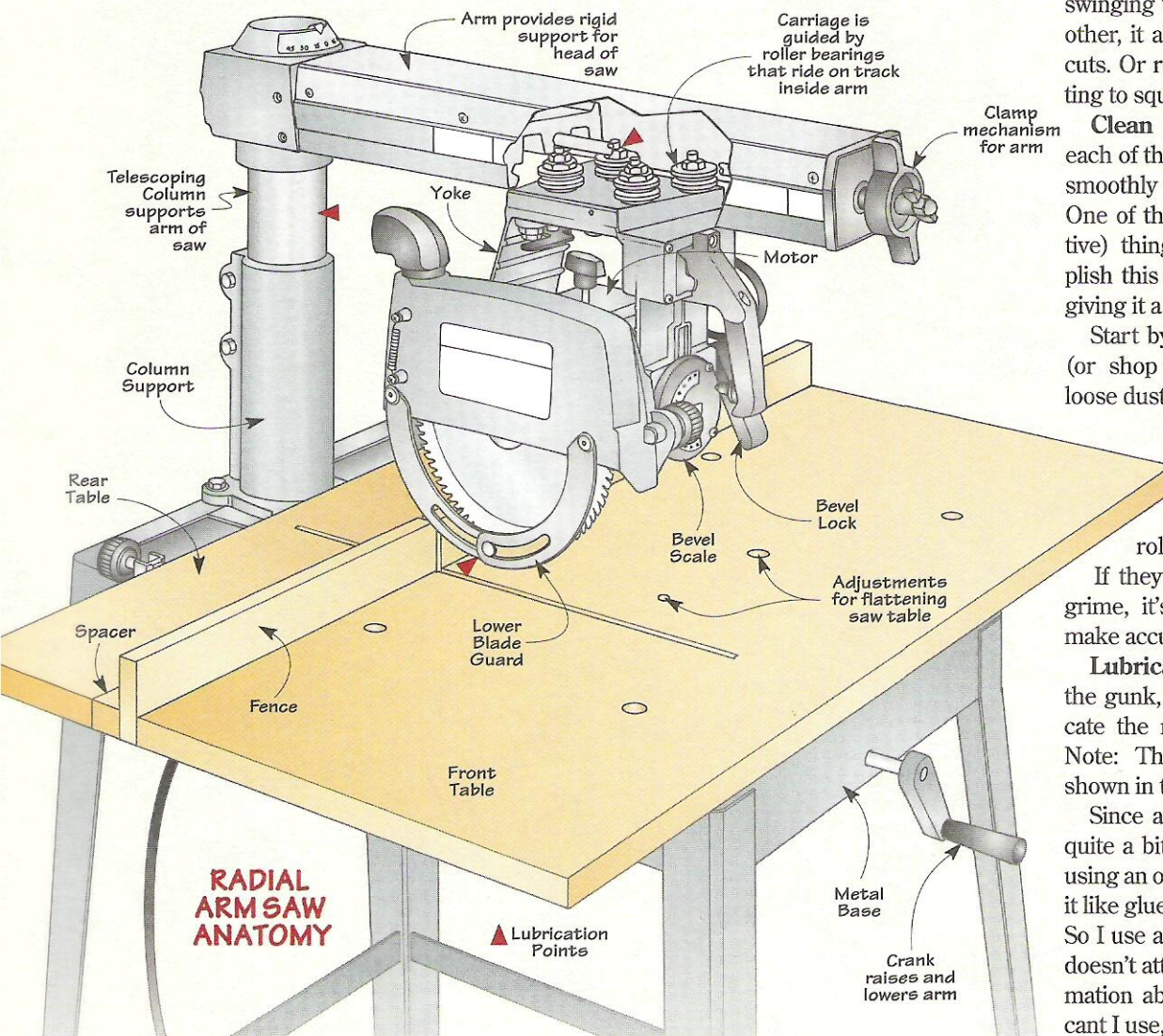



## 1. Adjust Column

The first step is to remove any “play” in the column. Ideally, it should fit snug (not tight) in two places: the *column support* and the *arm*.

To check the amount of movement in the column support, grasp the end of the arm and lift it up and down, as shown at right. If the column moves front to back, tighten the column support (detail ‘a’).

If there’s any slop when you apply sideways pressure against the arm, just “snug” the adjustment screws against the column (detail ‘b’).

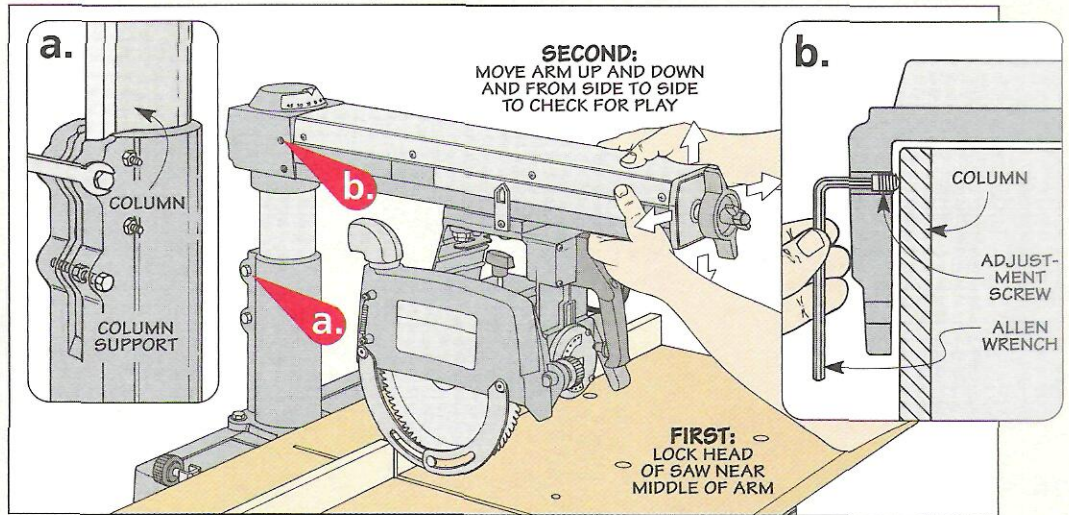

## 2. Check Bearings

The next step is to check the roller bearings that guide the carriage. When you pull the head of the saw forward, the bearings should glide smoothly without any side-to-side play.

If the movement feels sloppy (or there’s a lot of resistance), the bearings can be adjusted closer to (or farther from) the track inside the arm.

There are two bearings on each side, but only one pair is adjustable. These bearings are mounted off-center (detail ‘a’). So when you loosen a lock nut and rotate an adjustment nut, it moves the bearing in or out (detail ‘b’).

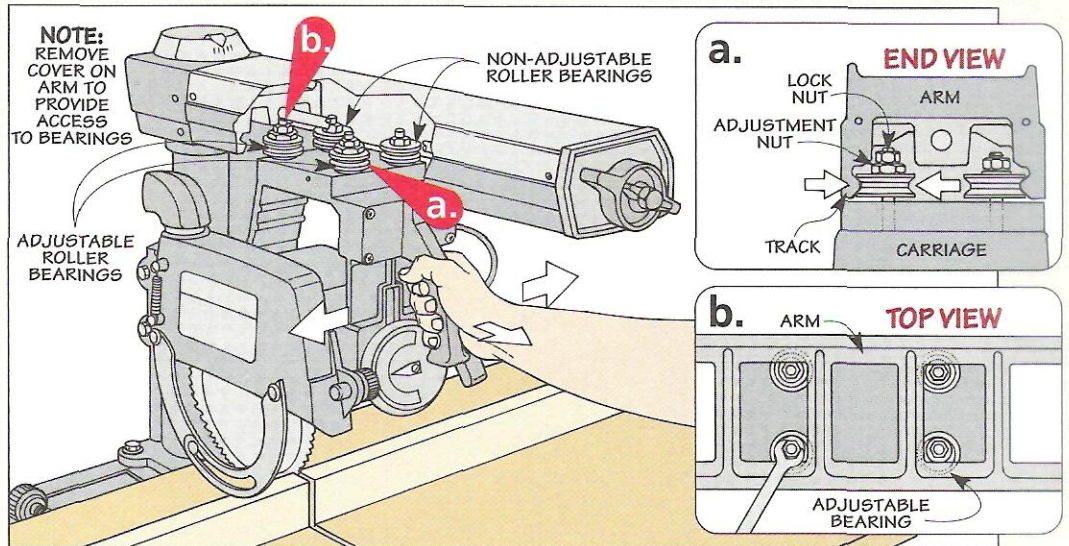

## 3. Flatten Table

To get consistent results, it’s important that the table is flat.

A quick way to test the flatness of the table is to lay a straightedge across the table and check for light underneath, as shown at right.

If the table is low, raise it by turning a set screw (detail ‘a’). If there’s a hump in the middle, tighten a machine screw to flatten it (detail ‘b’).

Note: With use, the saw table will get chewed up which can cause it to sag in the middle. So you may need to replace the table from time to time. To protect the surface of the new table, it’s a good idea to carpet tape a piece of hardboard to the top.

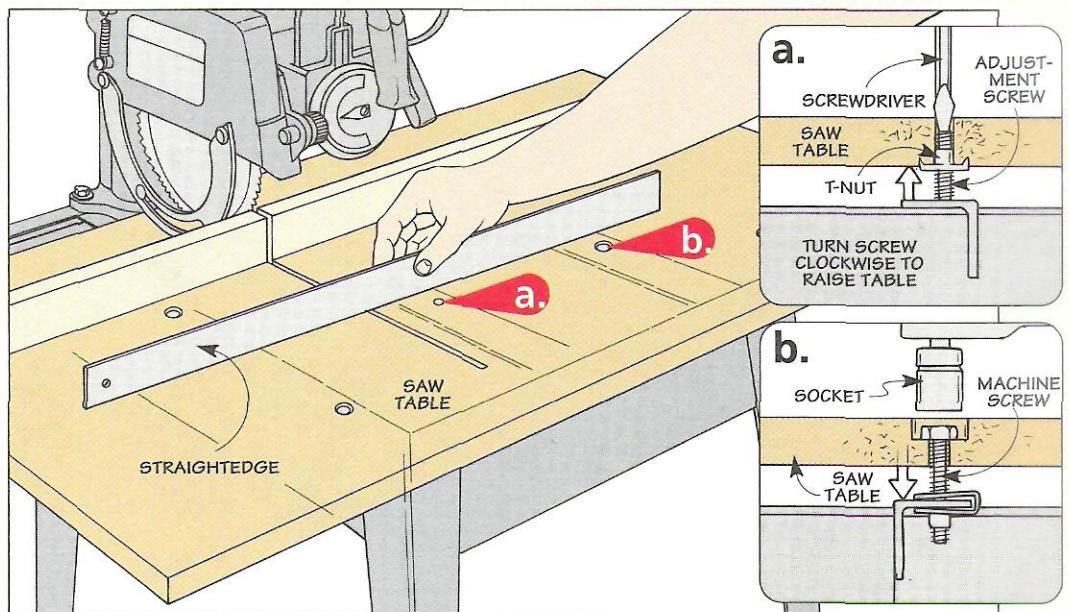



## 4. Align Table

Getting the table *flat* is one thing. But the surface of the table also needs to be *parallel* to the arm. Otherwise, when you crosscut a board (or cut a dado), the depth of cut will vary from one edge to the other.

Usually, there's no adjustment for the arm. So you'll need to align the table to the arm instead. This is done by raising or lowering a pair of metal brackets that connect the table to the saw (detail 'a').

To determine the amount of this adjustment, start by removing the blade guard and saw blade. Then release the bevel lock and rotate the head of the saw so the arbor points straight down, as shown at right. After securing the bevel lock, release the clamp mechanism for the arm so you can swing it from side to side.

The idea here is to slide the head of the saw along the arm so you can position the arbor at all four corners of the table. At each corner, the arbor should just barely touch a scrap block that's used as a feeler gauge. When that happens, the table is parallel to the arm.

I start with the back, right-hand

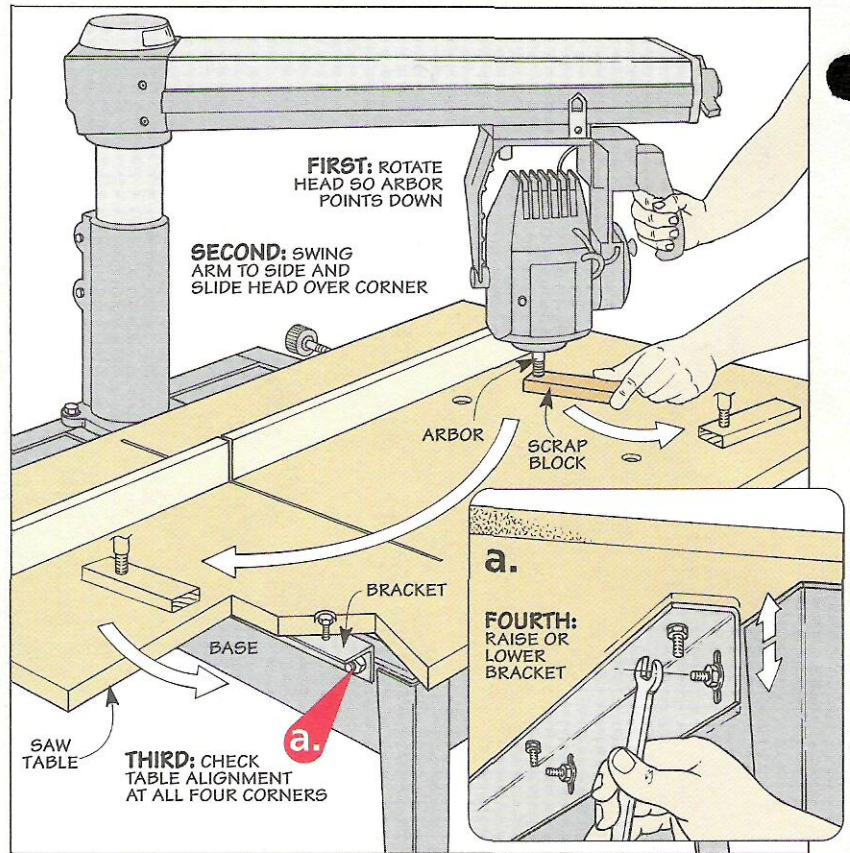

corner of the table. Begin by backing off the nut used to secure the bracket so it's just snug. Then lower the arm until the arbor just touches the block. When you can slide the

block back and forth with only slight resistance, tighten the nut that holds the bracket in place. Then, without changing the height of the arm, repeat the process at the other three corners.

## 5. Square Blade to Table

It goes without saying — to get a square cut, the blade has to be square to the table. But actually, there's more to it than that (more about that later). For now, let's just say that squaring

the saw blade to the table is the *initial* step in ensuring square cuts.

Start by checking that the clamp mechanisms for the arm, yoke, and carriage are locked. Then *unlock* the

bevel lock, grasp the motor, and wiggle it up and down to make sure the index pin is engaged at 90°.

After retightening the bevel lock, set a framing square against the blade. To get a "true" reading, be sure to place the square against the *body* of the blade, not the teeth.

If the blade is flat against the square, there's no need to make an adjustment. If it's tilted away from it (as in detail 'a'), it only takes a few minutes to square up the blade.

As you can see in the drawing at left, this is just a matter of removing the bevel scale to provide access to the adjustment bolts. After *slightly* loosening the bolts, tilt the motor to square up the blade. Then alternately retighten the bolts, replace the scale, and set the bevel indicator to zero.

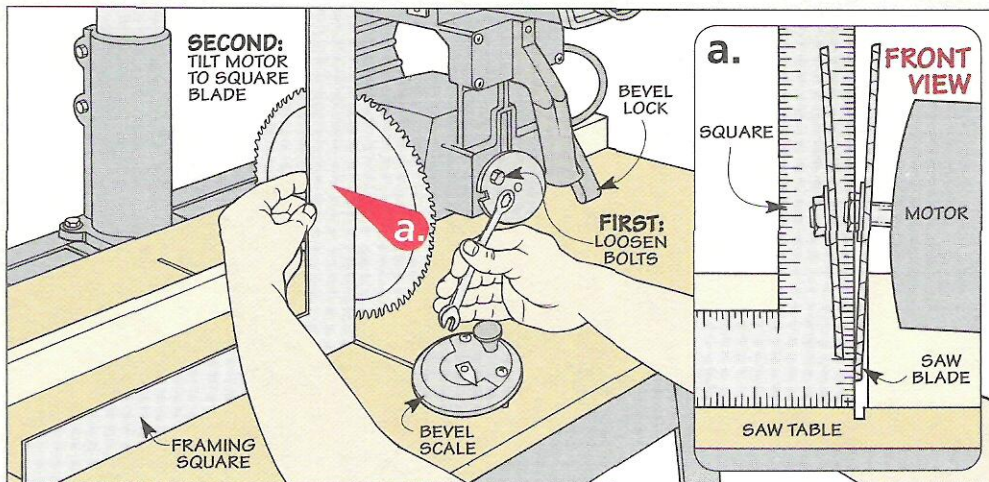



## 6. Square Up Arm

As I mentioned, squaring the saw blade to the table is just one part of the “squaring-up” process. The next step is to square the *arm* to the *fence*. This way, the saw blade will travel in a line that’s square to the fence.

Before you get started, check that the clamp mechanism for the arm is locked. Also, grasp the end of the arm and move it back and forth. This ensures that the index pin that holds the arm at 90° is properly engaged.

The first step is to find out if you even need to make an adjustment. To do this, I make a simple test using a framing square that’s resting on scrap blocks.

Start by placing the short “leg” of the square against the fence, as shown at right. Then mark a single tooth on the blade to use as a reference and slide the square against that tooth. Note: You may have to adjust the height of the blade to do this.

Now slowly pull the blade all the way forward, checking to see if the reference tooth stays in contact with the square. If the tooth scrapes against the square for the entire distance, the arm is square to the fence.

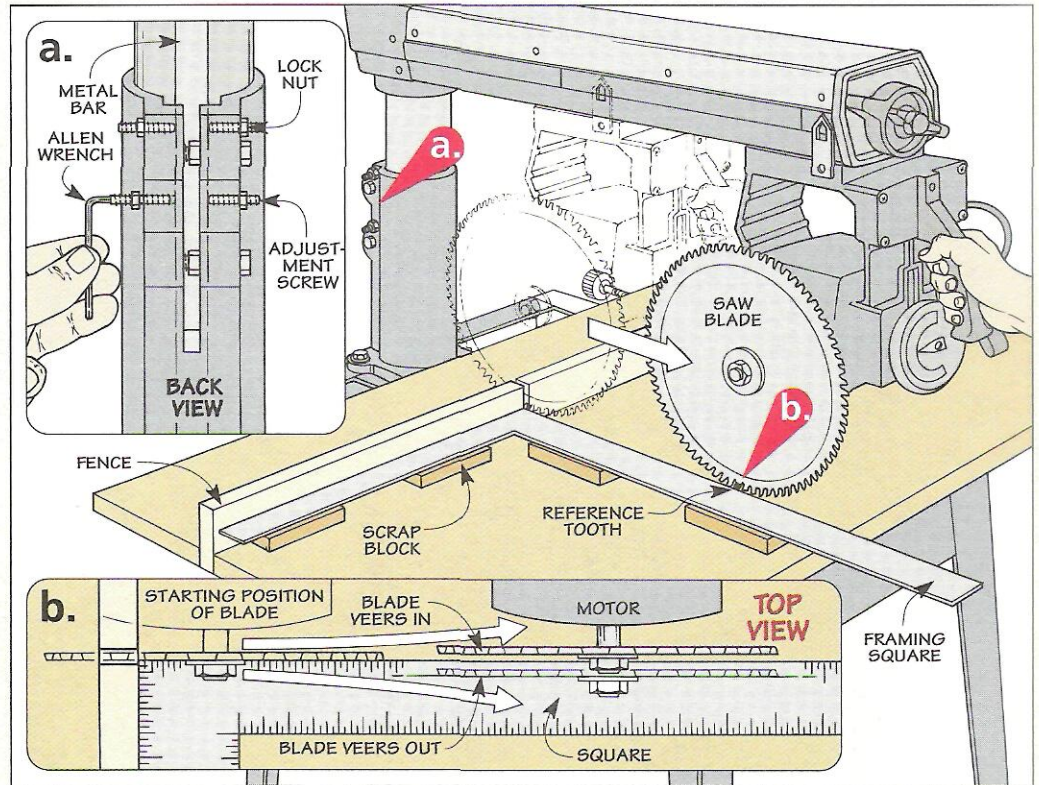

If it veers to one side or the other (detail 'b') the arm needs an adjustment. (If the blade moves *toward* the square, the scrap blocks prevent it from “climbing” up on the square.)

To adjust the arm, the idea is to apply pressure against a metal bar

welded to the back of the column (detail 'a'). On my saw, this requires loosening some lock nuts and tightening set screws against the bar to nudge the arm one way or the other. Note: Check the owner’s manual to find the adjustment on your saw.

## 7. Check for Heel

At this point, the blade *travel* is square to the fence. But that doesn’t mean the blade itself is square to the fence.

Sometimes the yoke (and therefore the blade) is slightly twisted on the carriage. This is called *heeling*. The problem with heeling is the blade “plows” a wide kerf, creating rough, burned edges.

It’s best to check for heel near the center of the blade where there’s more surface area. So I set a framing square on tall blocks, as shown in the drawing at right and detail 'b.' Note: You may need a tall fence to hold the short leg of the square against.

If the blade needs to be aligned, unlock the yoke and loosen the bolts used to secure it to the saw (detail 'a'). Then swivel the yoke to square up the blade and retighten the bolts.

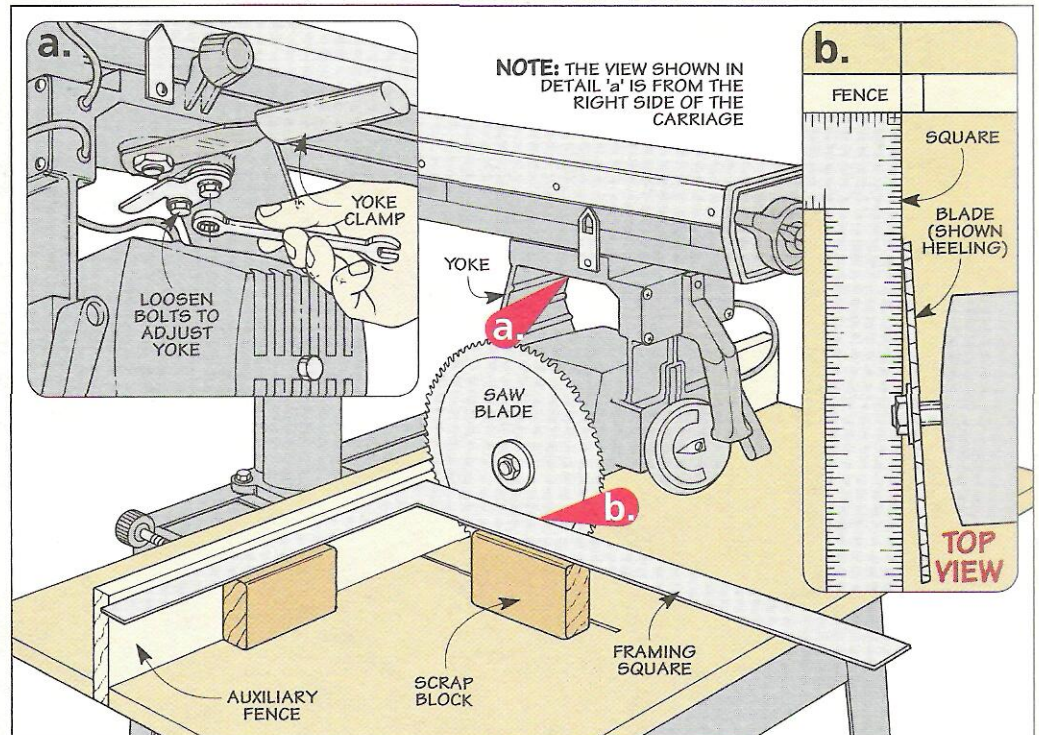



# Knock-Down Workbench



*Turn a single sheet of plywood and a few pieces of hardware into a portable workbench that “knocks down” for compact storage.*

**A** bench in a box. No, it's not a new magic act. It's what one of the guys calls my new knock-down workbench. When you think about it, it's a fitting description.

That's because the bench provides a solid, stable work surface like you'd expect from a bench. (There's even a tool tray underneath.) Then, once a job is completed, the bench can be “knocked down” and stored in a compact box that you carry like a suitcase. (See photo at right.)

The best thing about this knock-down design is it makes it easy to take the bench out to the driveway or back yard, or to a friend's house to help on a project. No matter where you're working, setting up the bench only takes a minute.

**Setup** – To do this, start by unlatching the lid on the box and setting it aside. (The lid doubles as the top of the workbench.) Then simply remove the two stretchers and flip up the sides of the bench, as shown in photo A below.

The sides are hinged to the base, so you'll need to “spring” them apart a bit to fit the stretchers between them (Photo B). These stretchers hook securely into the sides with an ordinary set of bed rail fasteners. Then just set the top down over the sides and pull it toward you to lock it in place (Photo C).

**Clamping Options** – Once the bench is set up, there are three different ways to clamp a workpiece to the benchtop. That explains the holes and slots in the top as well as the notches in the top of the stretchers. Note: For a closer look at the different clamping options, turn to page 23.

**Plywood** – Just one more note. You won't need a lot of material to build this bench. The entire project is made from a single sheet of 3/4" plywood. (I used pine plywood.)

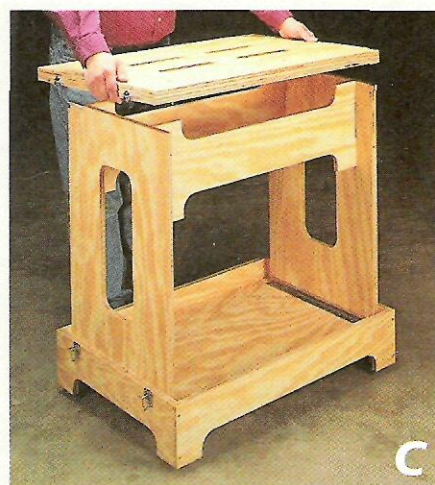
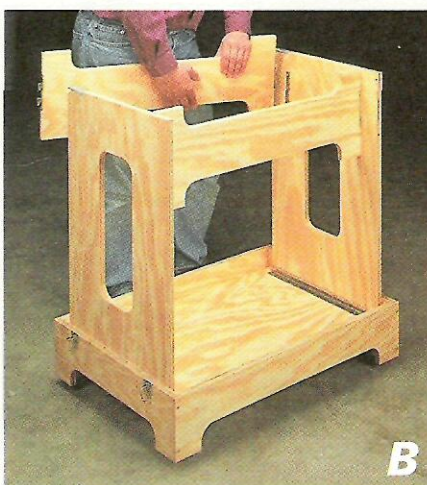
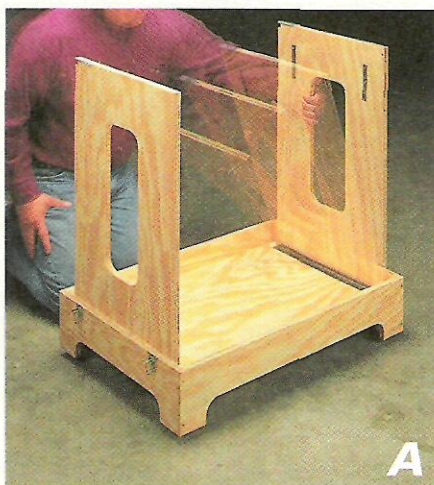

**Setup.** It only takes a minute to set up the workbench. After unlatching the top and setting it aside, remove the stretchers and flip up the sides, as shown in photo 'A.' To provide rigid

support for the top of the bench, the stretchers hook into the sides (Photo B). Then just fit the top down over the sides of the bench and pull it toward you to “lock” it in place (Photo C).



# FEATURE PROJECT

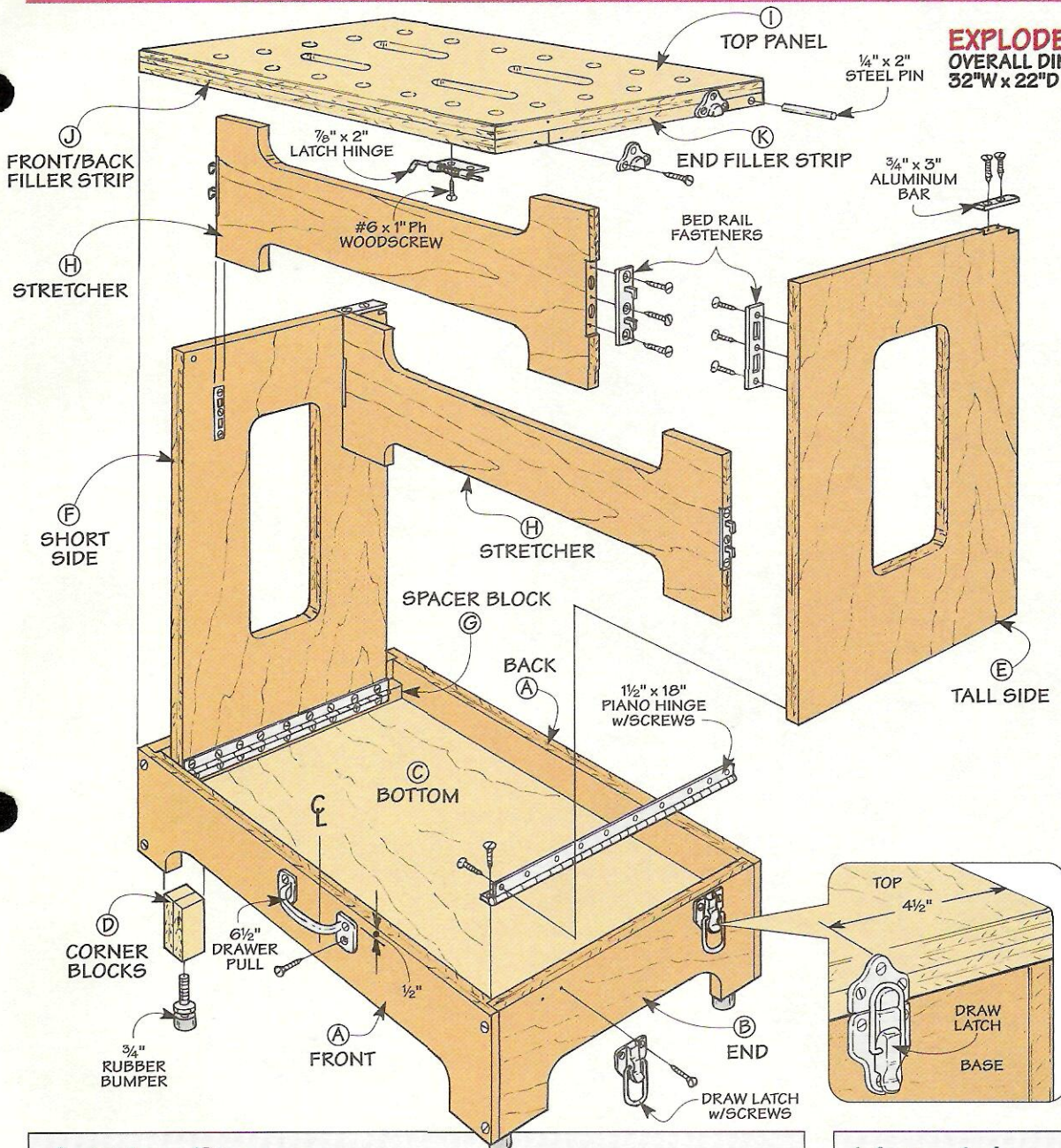

**EXPLODED VIEW**  
**OVERALL DIMENSIONS**  
 32"W x 22"D x 33<sup>3</sup>/<sub>4</sub>"H

## Hardware

- (12) #8 x 1/2" Fh Woodscrews
- (20) #8 x 1 1/2" Fh Woodscrews
- (4) #8 x 2" Fh Woodscrews
- (4) #10 x 1/2" Fh Woodscrews
- (4) #6 x 1" Panhead Woodscrews
- (1 Set) 4" Bed Rail Fasteners
- (2) 1/4" x 2" Steel Pins
- (2) 3/4" x 3" Aluminum Bar (1/4" thick)
- (1) 6 1/2" Drawer Pull
- (1 Set) 7/8" x 2" Latch Hinges
- (2) 1 1/2" x 18" Piano Hinges w/Screws
- (4) Draw Latches w/Screws
- (4) 3/4" Rubber Bumpers w/5/16"-18 x 1/4"-Long Stud
- (4) 5/16"-18 T-Nuts

## Cutting Diagram

48" x 96" x 3/4" PLYWOOD

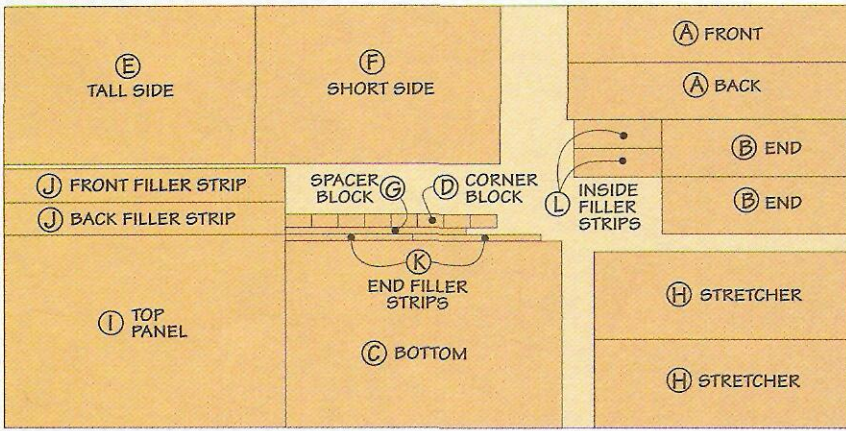

## Materials

### Base

- |                     |                            |
|---------------------|----------------------------|
| A Front/Back (2)    | 6 1/2 x 32 - 3/4 Ply.      |
| B Ends (2)          | 6 1/2 x 21 1/4 - 3/4 Ply.  |
| C Bottom (1)        | 21 1/4 x 31 1/4 - 3/4 Ply. |
| D Corner Blocks (4) | 1 1/2 x 3 - 1 1/2 Ply.     |

### Supports

- |                    |                         |
|--------------------|-------------------------|
| E Tall Side (1)    | 18 x 28 1/2 - 3/4 Ply.  |
| F Short Side (1)   | 18 x 27 3/4 - 3/4 Ply.  |
| G Spacer Block (1) | 3/4 x 20 1/2 - 3/4 Ply. |
| H Stretchers (2)   | 10 x 29 - 3/4 Ply.      |

### Top

- |                             |                         |
|-----------------------------|-------------------------|
| I Top Panel (1)             | 22 x 32 - 3/4 Ply.      |
| J Fr./Bk. Filler Strips (2) | 3 3/4 x 32 - 3/4 Ply.   |
| K End Filler Strips (2)     | 3/4 x 14 1/2 - 3/4 Ply. |
| L Inside Filler Strips (2)  | 3/4 x 10 - 3/4 Ply.     |



# Base

I began work by making the *base* of the bench. As you can see in Figure 1, it's a shallow box with a large "foot-print" that helps the bench resist tipping. The base provides a handy compartment for tools while you're working. And when you "knock down" the bench for storage, the base holds the sides and stretchers.

**Frame** – The base starts out as a plywood frame that's made up of a *front/back* (A) and two *ends* (B). To strengthen the base (and help align the pieces during assembly), the front and back are rabbeted at each end.

An easy way to cut these rabbets is to use a dado blade mounted in the table saw. As you can see in Figures 2 and 2a, part of the blade is "buried" in an auxiliary fence that's attached to the rip fence with carpet tape.

The fence is positioned so the blade will cut the *shoulder* of the rabbet. The only problem is the front and back pieces are fairly narrow, too narrow to ride against the fence without twisting. To prevent that, I attached a long fence to the miter gauge and used it to guide the work-piece through the blade.

**Cut Grooves** – In addition to the rabbets, there's a groove in the inside face of each piece that holds the *bottom* of the base. The location of this groove determines the *depth*

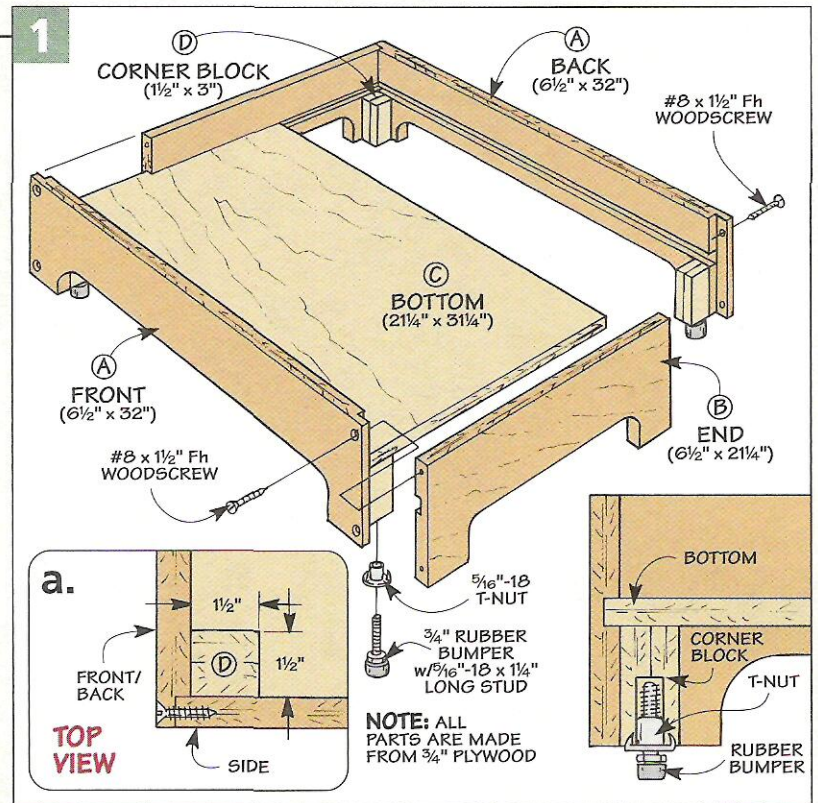

of the storage compartment in the base. I wanted to make sure the compartment was deep enough to hold the sides and stretchers (and still be able to fasten the top on the base).

So after adjusting the width of the dado blade to match the thickness of the plywood bottom, I set the rip fence  $3\frac{3}{4}$  inch away from the outside of the blade (Figures 3 and 3a). Running the *bottom* edge of each piece against

the fence will produce a groove that's  $2\frac{3}{4}$  inch down from the top edge. This provides enough room for the sides and stretchers plus a little extra.

**Notches** – After completing the grooves, I cut a long notch in the bottom edge of each piece (Figures 4a and 4b). These notches provide some "toe room" so I can work at the bench without kicking the base. A sabre saw (or band saw) is all that's

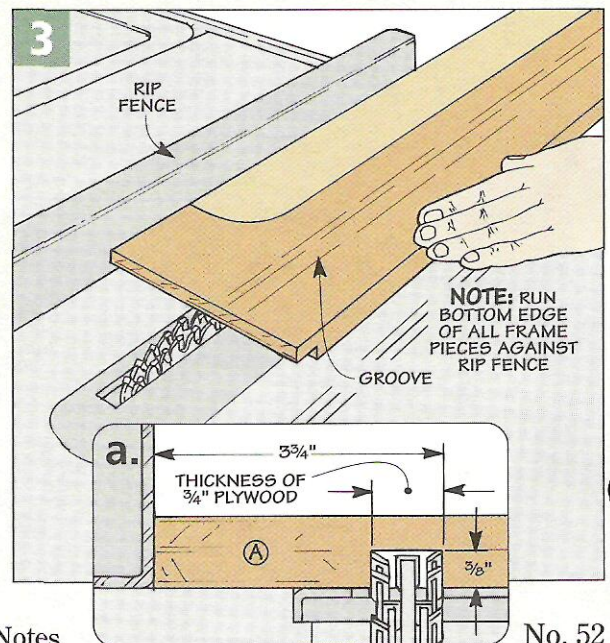
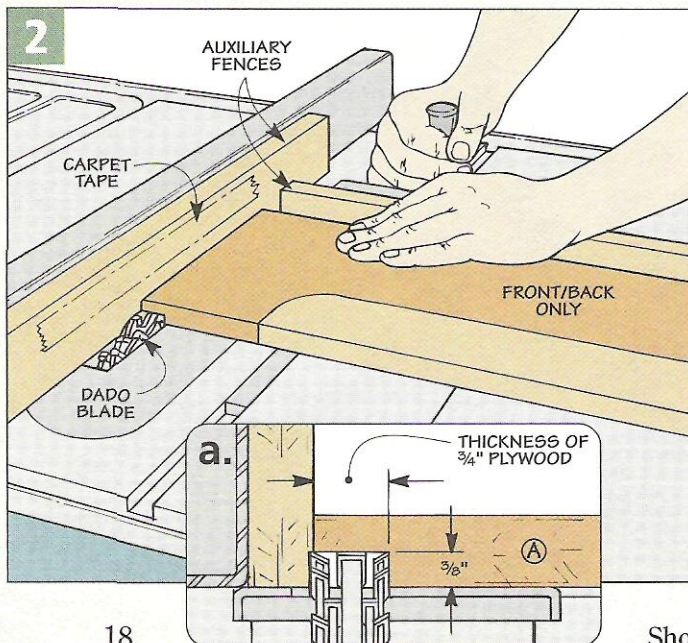



needed to cut the notches to rough shape. And a drum sander chucked in the drill press makes quick work of removing the rest of the material.

But a drum sander can create a scalloped edge if you're not careful. To prevent that, I used a long, straight scrap piece as a fence (Figure 4). With the "feet" of the workpiece riding against the fence, it's easy to sand a straight edge.

To sand the entire thickness of the edge, you'll need to attach an auxiliary table to the drill press and cut a hole in it to accept the drum sander. Then, after notching the fence to fit around the drum sander, position it to sand to the desired depth and clamp the fence in place.

Now turn on the drill press, and push the workpiece into the drum sander until it contacts the fence. The idea is to start at the *right* end of the notch, then slowly feed the workpiece from left to right to sand the edges smooth.

**Bottom** – Before assembling the base, there's one more thing to do. That's to cut the plywood *bottom* (C) to fit. Then just glue and screw the base together. I also "eased" all of the edges with a sanding block to keep them from splintering when they get bumped or knocked around.

**Corner Blocks** – All that's left to complete the base is to add four

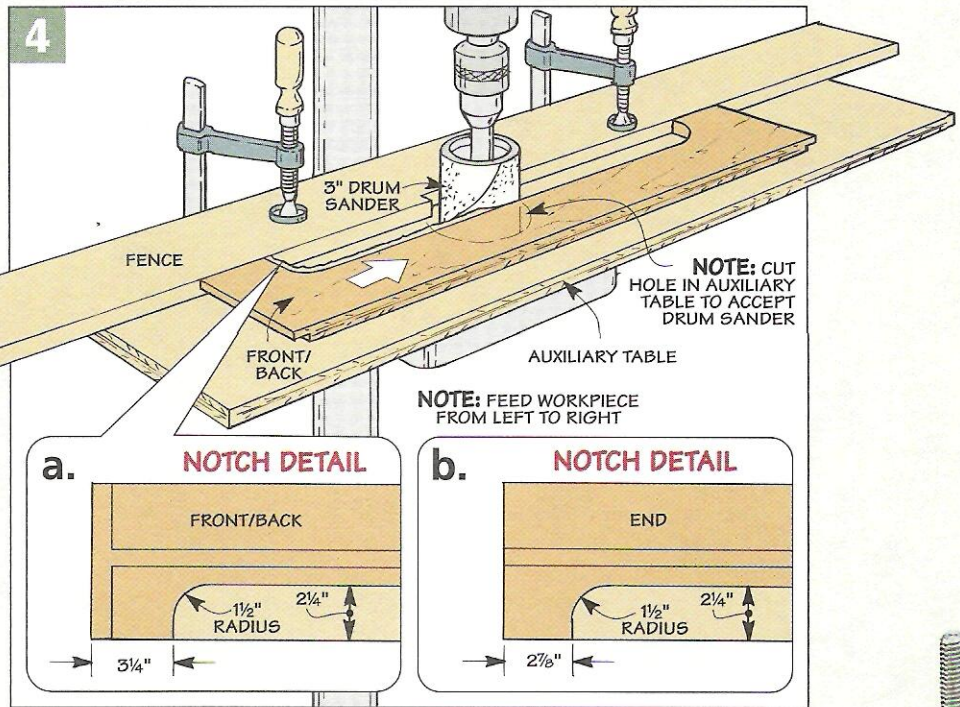

thick *corner blocks* (D). These blocks "beef up" the corners of the base to hold a set of rubber bumpers that are added later (Figure 1).

Each corner block is made up of two pieces of 3/4" plywood. To avoid working with small pieces, I glued up two long strips of plywood first (Figure 5). Then it's just a matter of cutting each corner block to length.

Here again, a fence attached to the miter gauge provides support for the blank. But this time, to cut each block to the same length, I clamped a

scrap piece of wood to the rip fence and used it as a stop. The idea is to set the fence so that when you butt the end of the blank against the stop, it will produce a 3"-long corner block.

**Rubber Bumpers** – After cutting all the corner blocks, the next step is to add a set of four rubber bumpers. (We've shown two in the margin.) These bumpers thread into T-nuts that fit into a hole drilled in each corner block (Figures 6 and 6a). After gluing the blocks in place, simply tap in the T-nuts and install the bumpers.



▲ Hard rubber bumpers thread into the base of the bench to keep it from sliding around and to prevent damage to a finished floor. (See page 31 for sources.)

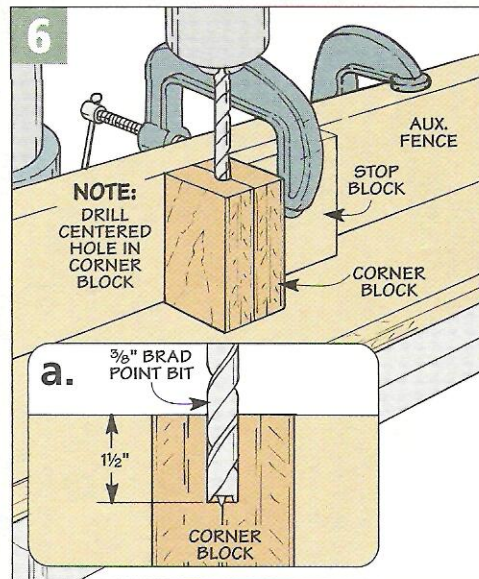
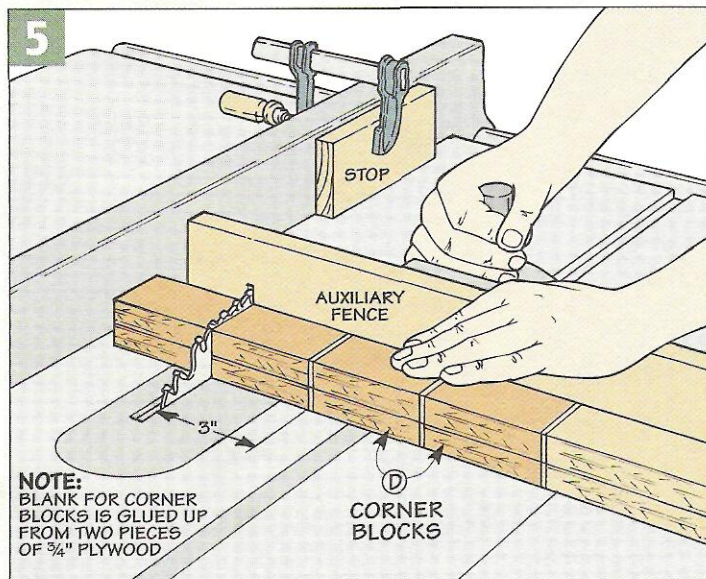



# Supports

This workbench is designed with a simple system of interlocking parts that provide solid support for the top. As you can see in Figure 7, it consists of two hinged *sides* connected by a pair of *stretchers*.

To prevent the bench from racking, the connection between the sides and stretchers must be rigid and strong. At the same time, I wanted a quick and easy way to take them apart.

**Bed Rail Fasteners** – The solution is a mechanical fastener like the type used to hold the parts of a bed together. (See photo at left.) One part of the fastener (attached to the end of the stretcher) has two hooks that fit into slots in the other part (mounted to the sides). This “locks” the parts together, yet still allows them to be quickly disassembled.

**Sides** – I started by making the two sides of the bench. Both sides are the same width (18"). And they appear to be the same length. But that's not the case. To allow both sides to fold flat inside the base, the *tall side (E)* is  $\frac{3}{4}$ " longer than the *short side (F)*, as shown in Figure 8.

Aside from the difference in length, the sides are identical. To reduce the weight of the bench, I cut a large opening in each side. Also,

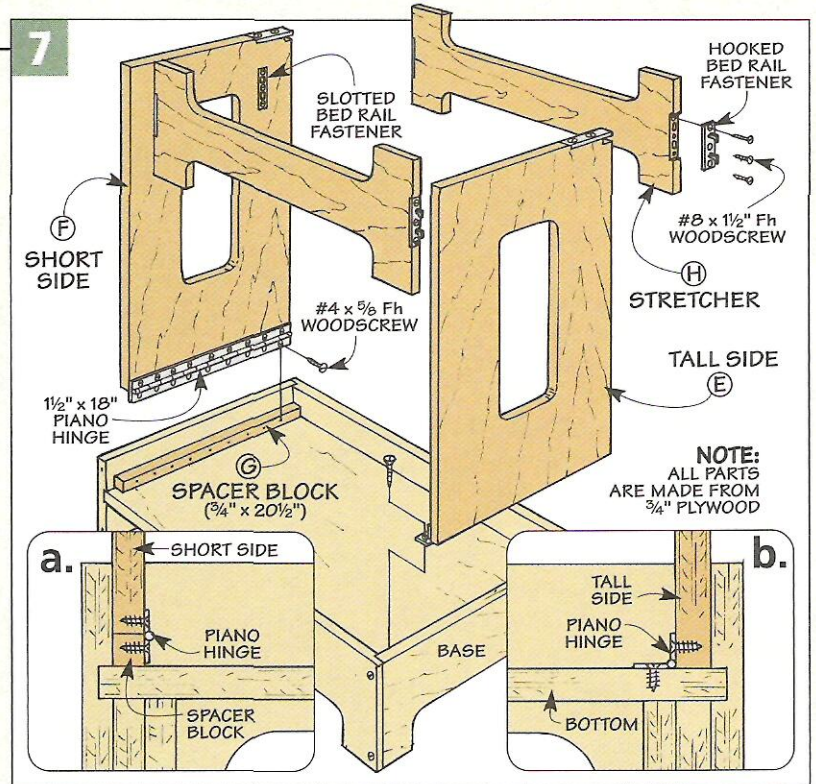

▲ A two-piece bed rail fastener creates a strong, rigid connection that's quick and easy to take apart. (See page 31 for sources.)

there's a short, metal bar on the upper back corner of each side that's used to secure the top to the bench.

**Bars** – The two metal bars are easy to make. I bought a  $\frac{1}{4}$ "-thick aluminum bar at a home center and used a hack saw to cut each one to length. Then I drilled a couple of countersunk shank holes in each piece for mounting screws.

Before attaching the bars, you'll

need to cut a “stairstep” notch in the corner of each side. The upper part of this notch is sized to fit the bar (Figure 8a). When you screw the bar in place, it forms a lip over the lower part of the notch. This lip captures a pin that's installed later in the top.

**Cut Mortises** – The next step is to cut the mortises that hold the slotted part of the bed rail fasteners. As you can see in Figure 8a, the idea is to cut a two-tiered mortise. A wide, shallow mortise is sized to accept the fastener, and two narrow, deep mortises provide clearance for the hooks on the other part of the fastener.

An easy way to make the shallow mortises is to use a drill press and a Forstner bit (Figure 9). A careful layout will ensure that the upper ends of the mortises align. As for the distance of the mortises in from the edge, I clamped a fence to the drill press table and used it to position each workpiece. Now it's just a matter of drilling a series of overlapping holes and paring away the remaining waste with a chisel (Figure 9a).

Once the fastener fits neatly in the mortise, you can use it to lay out the location of the two *deep* mortises

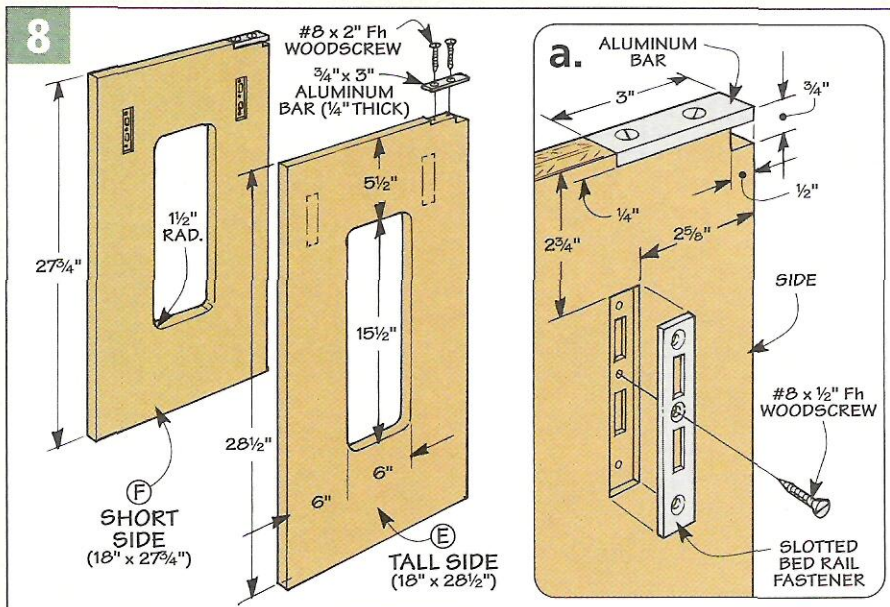



(Figure 9b). The thing to be aware of is these mortises are  $\frac{5}{16}$ " longer than the slots in the fastener. The reason has to do with the hooks on the mating fastener. To lock the two parts of the fastener together, the hooks have to fit straight into the slots and then slide *downward*. Increasing the length of the mortise provides the clearance that's needed for the hooks.

After laying out the deep mortises, chuck a smaller bit in the drill press and use the same procedure as before to cut two pockets (Figure 9c). Then screw the fasteners in place.

**Install Sides** – Now you're ready to install the sides. The tall side (E) is hinged directly to the base (Figure 7b). But as you can see in Figure 7a, the short side (F) is hinged to a *spacer block* (G). This is a  $\frac{3}{4}$ "-square strip of plywood that's glued to the base. The spacer block raises the short side so it can fold down flat across the tall side.

**Stretchers** – The next step is to add the *stretchers* (H). As you can see in Figure 10, these are long, I-shaped pieces of plywood that are cut to length to fit between the sides.

Each stretcher has a long notch cut in the top and bottom edge. The upper notch lets you slip a pipe clamp underneath the benchtop so you can clamp a workpiece against

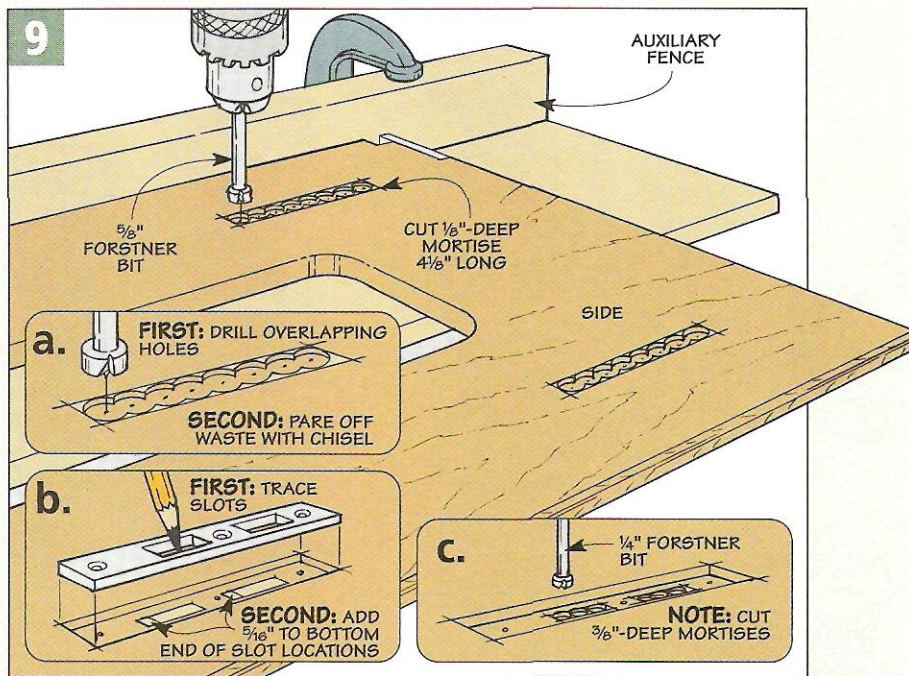

the edge of the bench. The lower notch is simply cut to match.

After sanding the edges smooth, all that's left is to add the *hooked fasteners* (Figures 10 and 10a). Each of these fasteners fits in a shallow notch in the end of the stretcher.

The location of these notches determines the up and down position of the stretchers. I wanted the stretchers to sit flush with the top of the sides, so the notch is  $2\frac{3}{4}$ " down from the top edge (Figure 11a).

An easy way to cut the notches is to mount a dado blade in the table saw and to attach a tall fence to the miter gauge (Figure 11). Then stand the stretcher on end, hold it firmly against the fence, and nibble away the waste.

Before attaching the fasteners, take a look at the back of each one. You'll notice there's a large "nib" behind each hook. To make the fastener sit flat in the notch, you'll need to drill a pocket for each nib. Then just screw the fasteners in place.

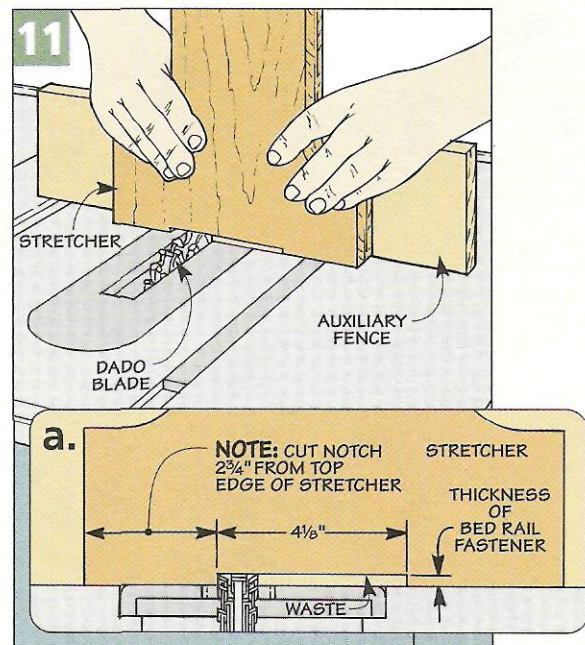
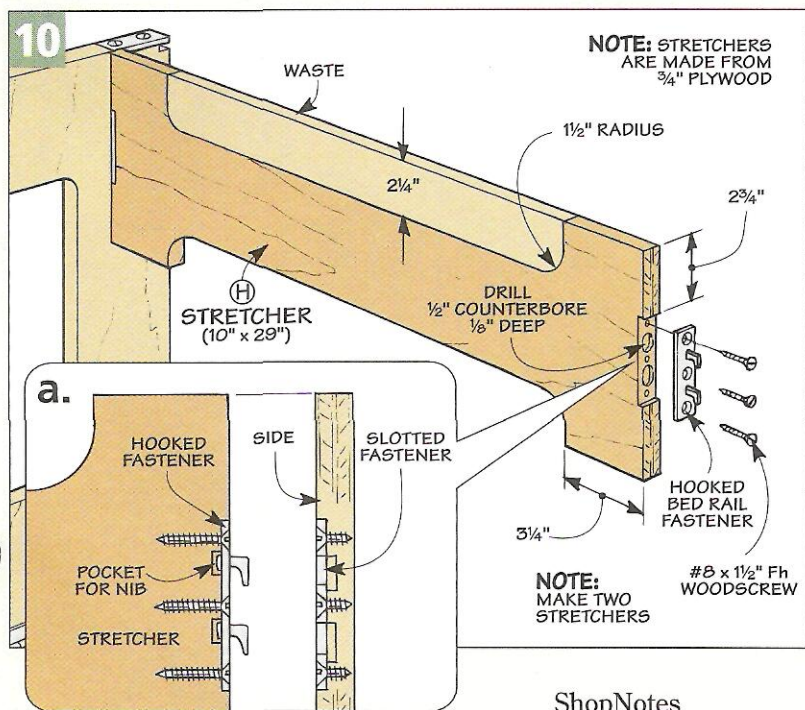



Top

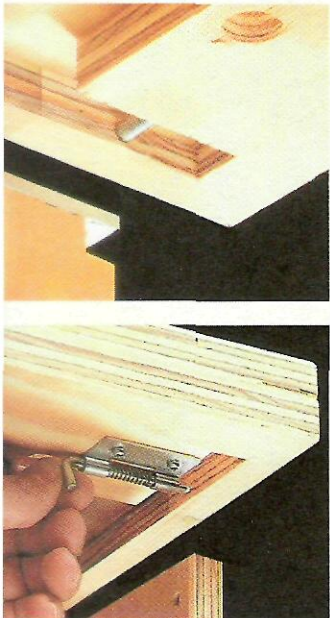

The top of the workbench that's shown in Figure 12 has two main jobs. It creates a solid worksurface. Plus it serves as a lid for the base when you knock down the bench for storage.

But the handiest thing about this benchtop is it provides three different ways to clamp a workpiece to the bench. (Refer to the photos on page 23.)

**Built-Up Top** – To increase the thickness of the top, it's "built up" from two layers of 3/4" plywood. The upper layer is formed by a *top panel* (I) that's sized to fit flush with the base (Figure 13). And the lower layer is made up of several smaller *filler strips*.

**Filler Strips** – These strips create a long, narrow recess underneath the top which fits down over the sides of the bench. Plus they provide the thickness that's needed to hold a set of bench dogs. (For more about the bench dogs I used, turn to page 31.)

The *front* and *back filler strips* (J) are simply cut to match the length of the top panel. To fit over the sides of

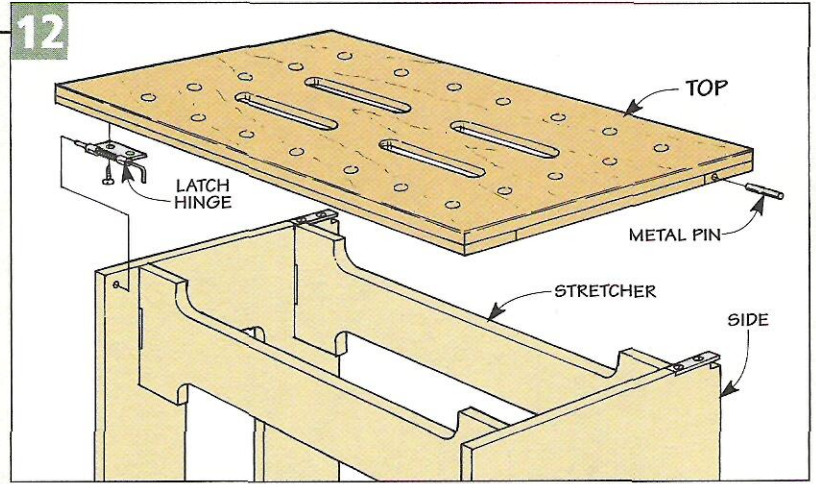

the bench, you'll need to cut a notch near each end of these strips. Then just glue them in place.

Next, I added two narrow *end filler strips* (K). They're ripped to width so when they're flush with the outside edge of the top, they align with the notch in the front/back strips. As for length, it's just a matter of cutting them to fit the opening.

After gluing on the end strips, I added two *inside filler strips* (L). To provide clearance for the stretchers, these strips are *shorter* than the end strips. Here again, the strips are aligned flush with the notch and

then glued in place.

**Slots for Clamps** – With the filler strips in place, the next step is to cut four slots in the top. Each slot forms an opening for a bar clamp that lets you clamp work near the middle of the benchtop. A quick way to cut each slot is to drill a small starter hole and then remove the rest of the waste with a sabre saw (Figure 14).

**Bench Dog Holes** – In addition to the slots, I drilled a number of holes in the top to hold the bench dogs. Since the top is quite large, I clamped an auxiliary table to my drill press to support it (Figure 15). It's

▲ A simple two-part system is used to fasten the top to the bench. Metal pins in the top fit under the aluminum bars on the sides (upper photo). And spring-loaded latches lock the top in place (lower photo).

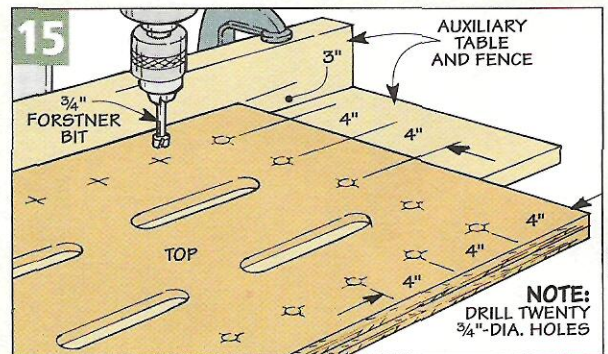
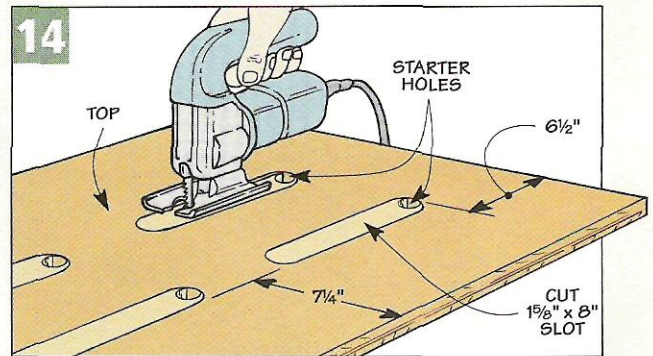
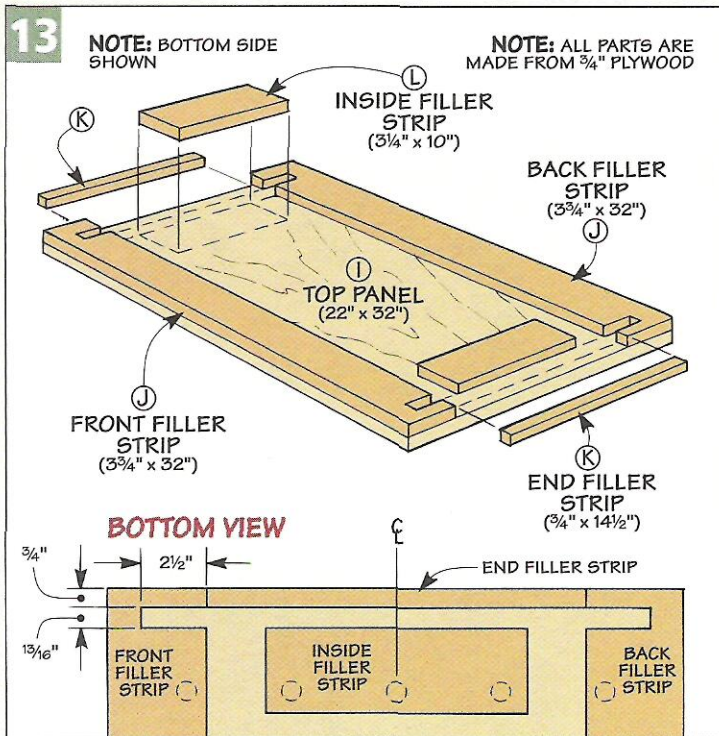



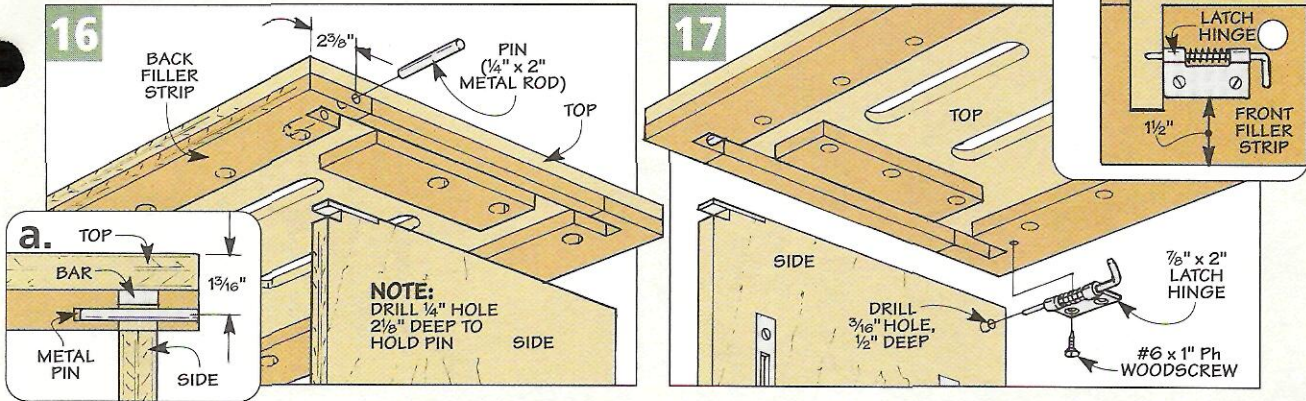

also a good idea to clamp a fence to the table to make sure the holes are located the same distance in from the edge. Then lay out and drill the holes.

**Locking System** – At this point, the top is almost complete. But before setting it on the bench, I added a simple, two-part system that “locks” it securely in place.

If you look at the photos on page 22, you can see how this works. In back, the top is held in place with two metal pins that fit under the aluminum bars installed earlier. In front, it’s secured with a couple of spring-loaded latch hinges.

**Install Pins** – As you can see in Figure 16, each pin is a short piece of 1/4"-dia. metal rod. The pin fits into a hole drilled in the end of the back filler strip (Figure 16a). After applying a small amount of epoxy in the hole, tap in the pin and clean up any excess that squeezes out.

**Latch Hinges** – The second part of the locking system is a pair of latch hinges. Each latch hinge has a spring-loaded pin that fits into a hole in the side of the bench (Figure 17). (For a source of latch hinges, refer to page 31.) An easy way to locate the holes for the spring-loaded pins is to screw the latch hinge to the top, as shown in Figure 17a. Note: The latch hinges I purchased didn’t have mounting holes, so I had to drill a couple of holes in each one.

Now lower the top down over the sides and pull it toward you so the metal pins in back slip under the aluminum bars. After centering the top from front to back, tap each of the spring-loaded pins to make a

dimple in the side. Then simply remove the top and drill the holes for the latch pins.

**Draw Latches** – In addition to the latch hinges, I also installed two draw latches on each end of the bench. (Refer to Exploded View on

page 17.) These latches hold the top and base together when you knock the bench down for storage.

**Handle** – All that’s left is to add a handle to make it easy to carry the bench. It’s centered on the front of the base and screwed in place.

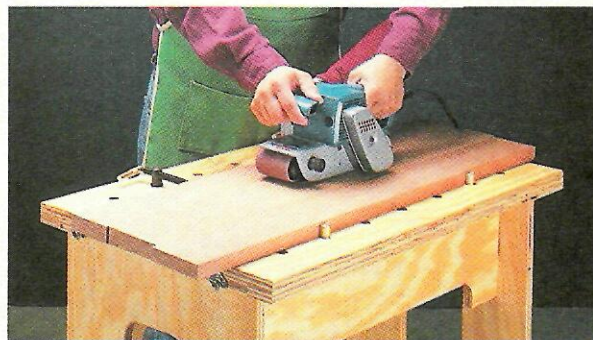
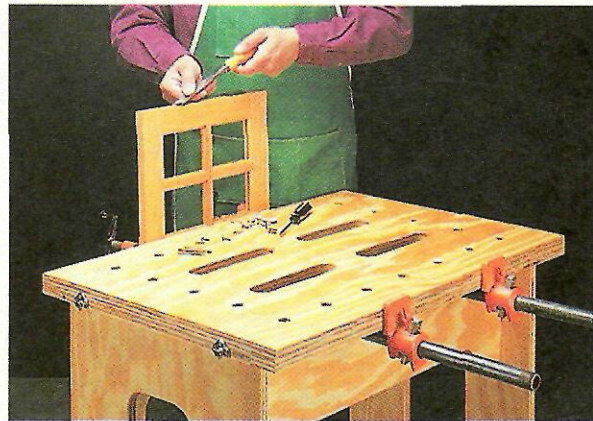

◀ **Pipe Clamps.** To hold a workpiece against the edge of the bench, slip pipe clamps through the notches at the top of the stretchers.



◀ **Bar Clamps.** Fit the head of a bar clamp down through one of the slots in the top to clamp work near the middle of the benchtop.



◀ **Bench Dogs.** Using one (or more) pairs of bench dogs lets you hold work tightly against the top without clamps getting in the way.



# Cherry Saw Handle

Recently, I was poking around a second-hand store, and I came across an old hand saw. The weathered handle of the saw was broken in one place and missing a chunk of wood in another. (It's the handle in the *before* photo at left.) A long bolt held the handle together, but it was a clumsy "fix" at best. And years of use had almost worn the carving off the handle.

In spite of that, something about the saw intrigued me. So I picked it up to examine it more closely.

The blade was rusty and dull, but cleaning and sharpening it would take care of that. More important, none of the brass hardware pieces that held the saw blade in the handle were missing. (It's difficult to find replacement hardware.)

In short, the saw looked like it had the potential to be a quality tool. Not only that, the price tag was right. (At \$1.50, how could I go wrong?) So I bought the saw and decided to restore it to a usable condition.

**Sneak Peek** – If you'd like to take a peek at how it turned out, take a look at the *after* photo above. It's the same saw, only I've cleaned it up, had the blade sharpened (which cost \$7.50), and made a new handle.

**Slot** – Making the saw handle provided an interesting challenge. It has to do with the *slot* in the handle that holds the saw blade. This slot is quite thin (about the thickness of four playing cards). Plus, it's curved to match the profile on the end of the blade. No doubt the manufacturer used some sort of specialized tool to cut the slot (a tool I didn't have).

So how *do* you cut a thin slot in a handle? The answer is simple — you don't. Let me explain.



*Before*

*After*

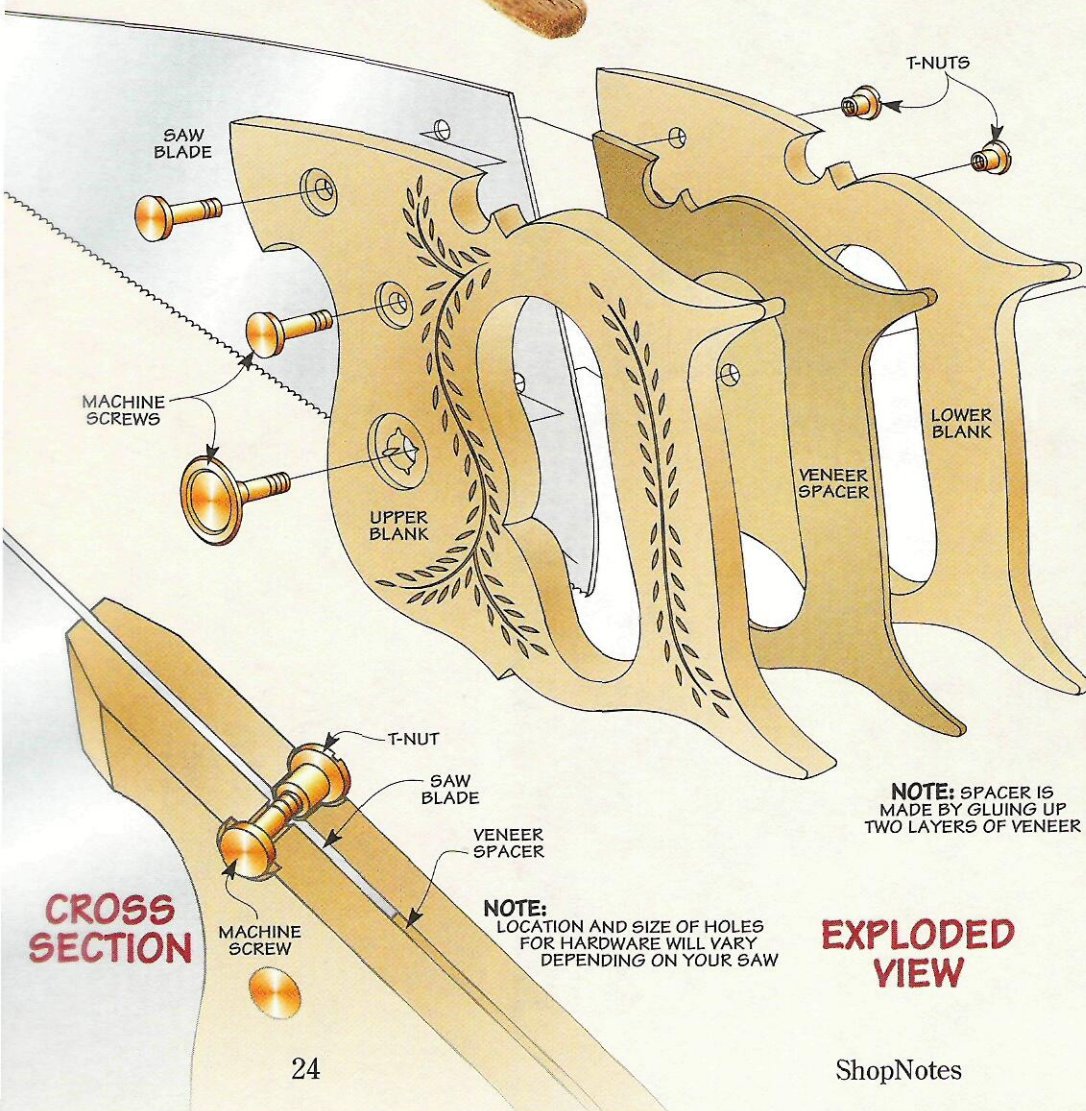

**CROSS SECTION**

**EXPLODED VIEW**



**Veneer** – The slot is made by using a double thickness of veneer as a spacer. As you can see in the Exploded View on page 24, the veneer is cut to match the shape of the blade and then glued between two hardwood blocks. This creates a thin slot that matches the shape of the blade exactly.

There's also a side benefit to using veneer. By orienting the grain of the veneer *across* the grain of the wood blanks, it strengthens the handle, so it's less likely to break.

**Traditional Shape** – Okay I know, this method for making a saw handle is a bit unorthodox. But I still wanted a traditional *looking* handle — one with a graceful, curved shape. Perhaps I'd even try my hand at carving a pattern in the handle like I'd seen on other old hand saws.

Before making the “real” handle, I experimented by making several versions out of softwood. This gave me a chance to modify the shape of the handle to get a comfortable grip. The shape I liked best is shown in the pattern above. Note: This is a half-size pattern, so you'll need to enlarge it by 200% on a photocopy machine.

**Carving** – After working out the basic shape, I drew several different carving patterns. As you can see, the one I ended up with is a simple wheat pattern. Of course, the handle would look great even without the carving. But if you decide to give it a try, we've included an article on page 28 that provides some useful tips.

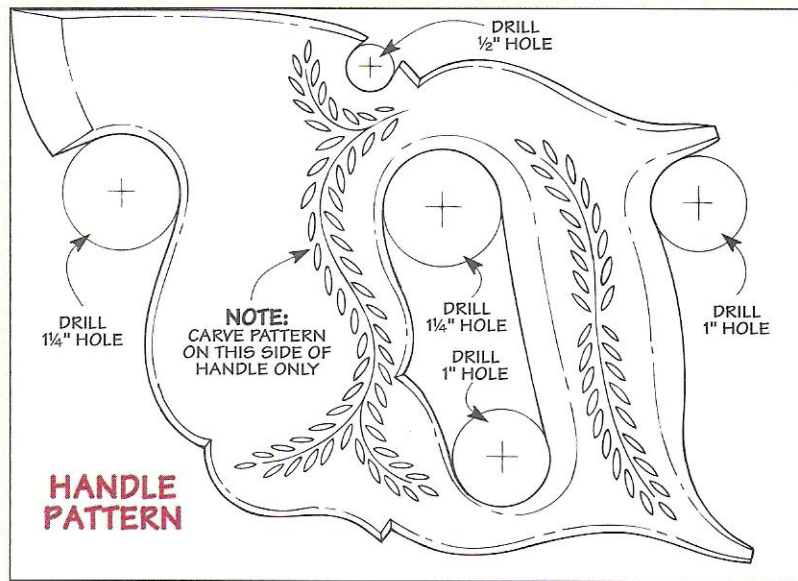

◀ To use this pattern to make a saw handle, enlarge it 200% on a photocopy machine.

**Three Layers** – To make the handle, I started by preparing the three layers of material (Figure 1). The idea here is to make the *combined* thickness of these layers equal to the thickness of the old handle. (Mine was just a hair more than 7/8" thick.)

The two outer layers are 7/16"-thick blanks of hardwood. (I used cherry.) And the middle layer is made up of two oversized pieces of veneer that are glued up and then trimmed to the same size as the two blanks.

**Transfer Pattern** – The next step is to transfer the pattern (including the wheat) to the upper blank *and* the veneer. Drawing the pattern on both pieces makes it easy to locate the holes for the hardware later on.

Also, to help simplify things when working with the handle pieces, I

made it a point to align the top edge of the pattern with the top edge of each piece before drawing the pattern. (For a tip on transferring a pattern, refer to page 28.)

**Trim Veneer** – Now it's just a matter of trimming the veneer to match the shape of the saw blade. As you can see in Figure 2, the end of the blade serves as a handy guide when cutting the veneer.

Start by positioning the blade on top of the veneer. There are a couple of things to keep in mind here. First, the blade should align with the top edge of the veneer. Also, be sure the holes in the blade don't cover up the pattern for the carving. Now hold the blade firmly in place and make several scoring cuts with a knife to cut the veneer to shape.

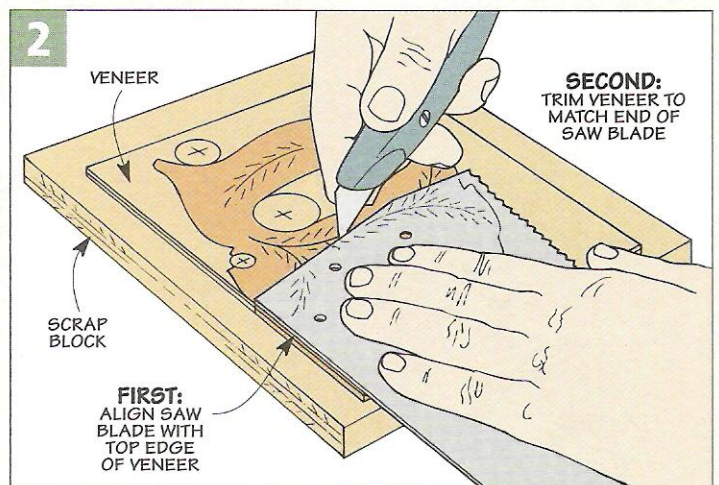
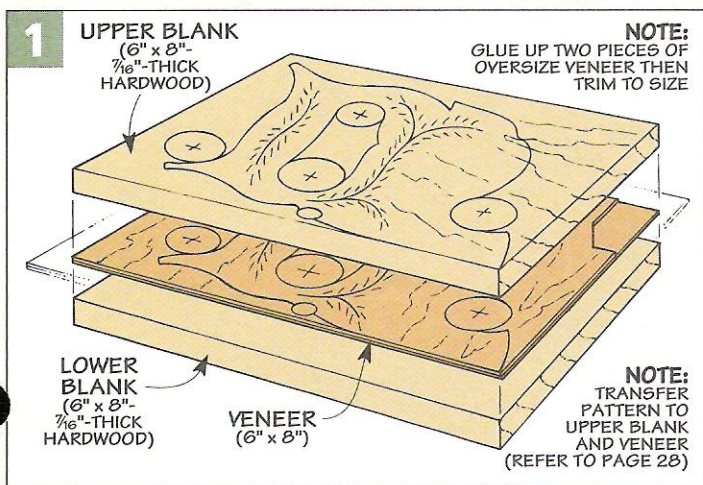



## Gluing & Shaping

Gluing up the three pieces of the handle sounds simple enough. The challenge is keeping the pieces from slipping out of alignment.

**Veneer** – Take the veneer for instance. As you can see in Figure 3, it's glued to the lower blank, flush on three sides. Now it's one thing to position the veneer while it's "dry." The trick is to make it stay put *after* the glue is applied.

What I found worked well here is to attach the saw blade to the lower blank with carpet tape. Then brush a *thin* film of glue on the veneer, butt it against the blade, and staple it to the blank. Clamping a scrap block over the veneer will help distribute the pressure, and wax paper prevents the block from sticking.

**Drill Holes** – Once the glue dries, you can remove the scrap block, but leave the blade in place. It provides a handy template for drilling the holes in the blanks that accept the blade hardware (Figure 4).

To ensure that these holes line up, I attached the upper blank to the *bottom* of the lower blank with carpet tape.

Note: The blanks are flush on all sides. Then chuck a bit in the drill press that matches the diameter of

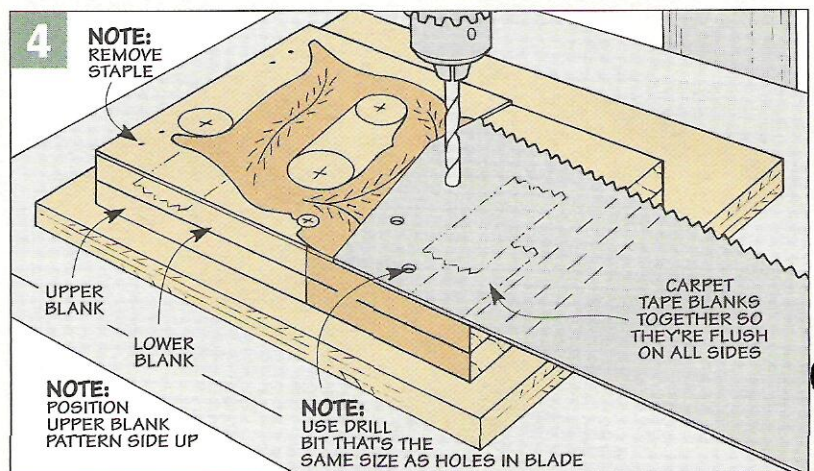
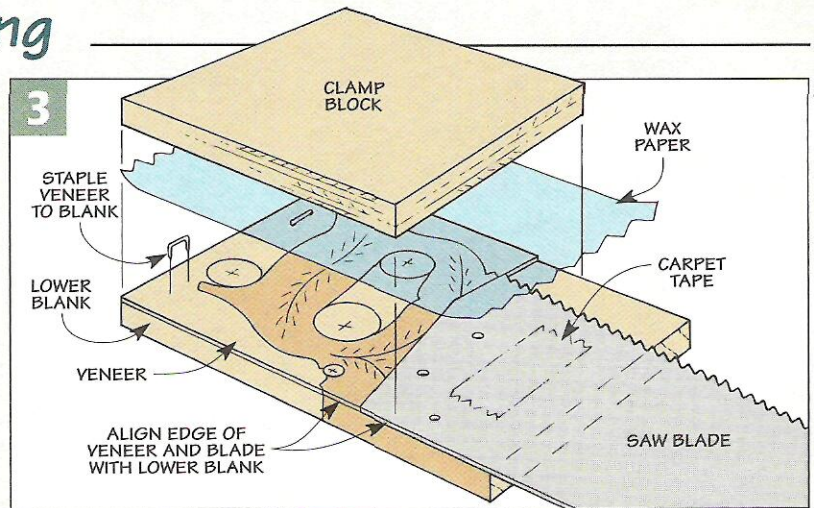

the holes in the blade and carefully drill the holes through both blanks.

**Upper Blank** – The next step is to glue on the upper blank. It's important that this blank doesn't shift. Otherwise, the holes you just drilled won't align. The solution is to insert

a couple of drill bits in the holes and use them as alignment pins when gluing and clamping the blanks together (Figure 5). Note: Be sure to use the same size bits as the holes.

**Blade Hardware** – Now you can turn your attention to the hardware that holds the blade in place. On my saw, there were three brass machine screws that thread into T-nuts. Note: Depending on your saw, the number of pieces of hardware (or size) is likely to vary.

Whatever the case, you'll need to drill counterbores in the handle to accept the machine screws and T-nuts. This requires drilling several counterbores, as shown in the detail on page 24 and the photos in the margin.

**Carve Handle** – If you're going to carve the handle, this is a good time to do it. The glued-up blank provides better support for your hand than after the handle is cut to shape.

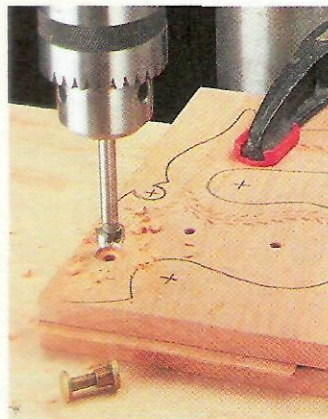
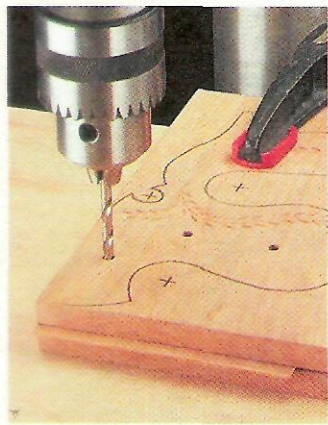
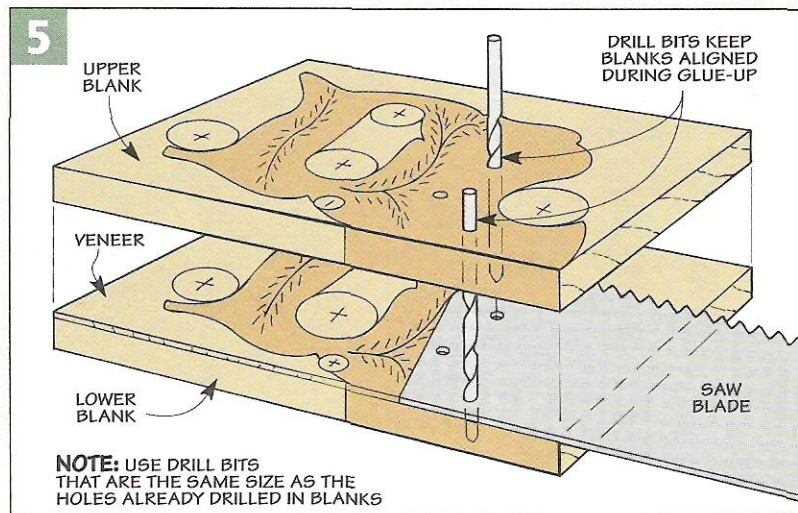

▲ It's easy to drill centered counterbores for the brass hardware on the existing holes. Use a small bit to position the blank on the drill press table (top) and then clamp the blank in place (top). Now chuck in a large bit and drill the hole (bottom).



**Shaping the Handle** – At this point, you're ready to start cutting the handle to shape. To create the tight curves of the handle, I drilled a number of holes (Figure 6). Note: Slipping a scrap of veneer into the slot will prevent chipout which could make it hard to insert the blade.

Next, to form the hand opening, I removed the waste between the holes with a sabre saw. A band saw made quick work of cutting the handle to rough shape (Figure 7).

Most of the remaining waste can be removed using a drum sander chucked in the drill press (Figure 7a). But plan on doing some handwork here. I filed and chiseled the tight places where it's hard to sand.

**Bullnose** – At this point, there are still a lot of sharp edges on the handle. So I decided to create a bullnose profile all the way around the handle and the grip. A quick way to do this is to use a router table and round-over bit (Figures 8 and 8a). But don't get carried away. The idea is to "knock off" the corners by adjusting the bit for a *shallow* depth of cut.

Just a couple of notes here. The tips of the handle are fragile. So it's best not to rout near them. Also, because of the bearing on the bit, you can't rout into the small, circular opening at the top of the handle or the V-shaped "valleys." So I filed and sanded a matching bullnose in these areas.

**Hand Grip** – There's still some work to do on the hand grip. To create

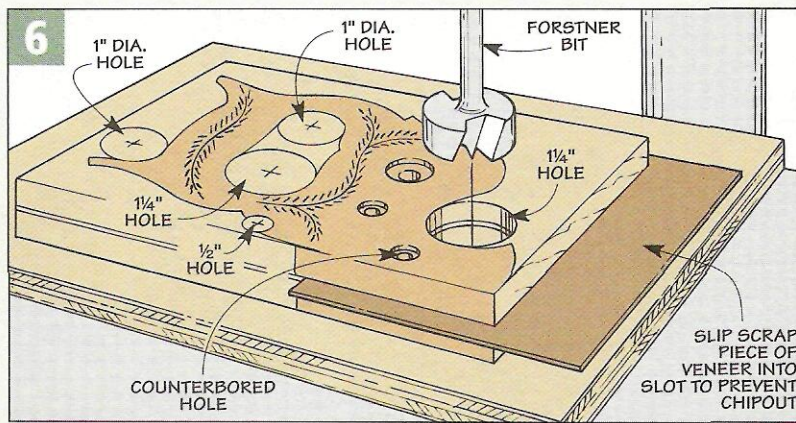

▲ A brass brush and some mineral spirits make quick work of cleaning the hardware that's used to hold the saw blade in the handle.

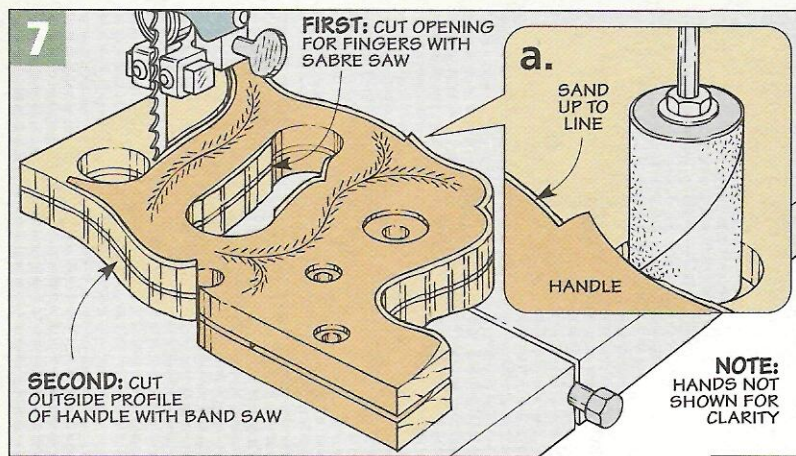

▲ A rubber block embedded with silicon carbide "erases" the rust on the saw blade.

a comfortable grip, I filed the top and bottom edges, blending it into a gentle oval shape (Figures 9 and 9a).

**File Chamfer** – While I was at it, I also filed a chamfer on the front edge of the handle (Figure 9b). This chamfer creates a smooth transition from the handle to the saw blade.

**Sand & Finish** – Now it's just a matter of *lightly* sanding the handle

and applying a finish. (I wiped on three coats of an oil varnish.)

**Assembly** – Finally, after cleaning up the brass hardware and the blade, as shown in the photos at right, I assembled the saw and gave it a try.

As it turns out, I couldn't have been more pleased with the results. My \$9 saw cut great, and it looked like a million bucks. 🛠️

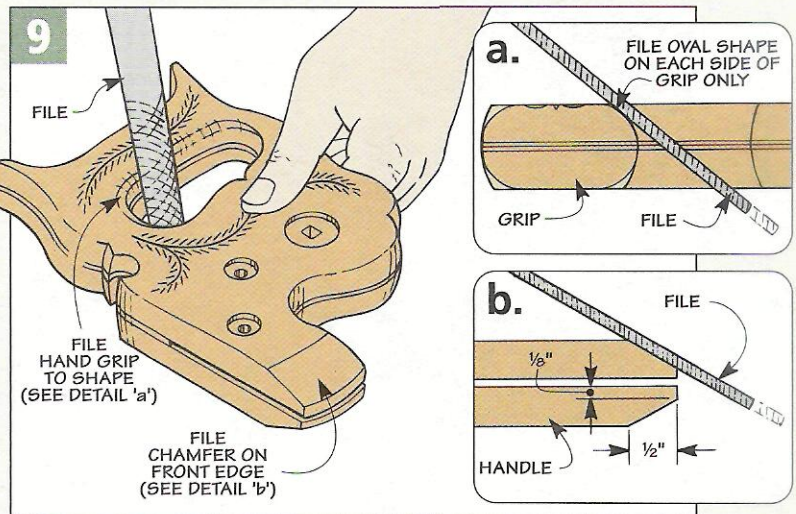
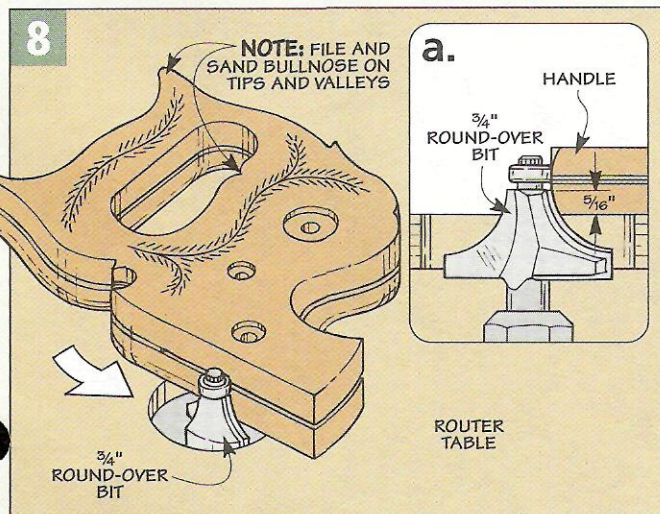



One of the things I like about old hand saws is the decorative carving on many of the handles. So when I was making the saw handle shown on page 24, I couldn't resist trying my hand at a little carving.

**Wheat Pattern** – As you can see in the photo at right, I carved a simple design in the glued up blank of the saw handle — a traditional wheat pattern. The stems of the wheat are formed by sweeping curved lines, and the kernels are made by cutting small, almond-shaped pockets.

**Chip Carving** – This type of carving is called *chip carving*. That's because the pattern is produced by removing tiny chips of wood. If you've never done any chip carving, it's easy. All it takes is a single, short-bladed knife and a little practice.

Each chip is formed by making *two* slicing cuts. You just plunge the knife into the workpiece and draw it toward you to sever the wood fibers on one side. Then repeat the process on the other side to lift out the chip.

**Carving Knife** – The carving knife I use (shown at left) has a short, stiff blade. This makes it easy to manipulate the knife. Plus the blade doesn't bend or flex when carving the chips.

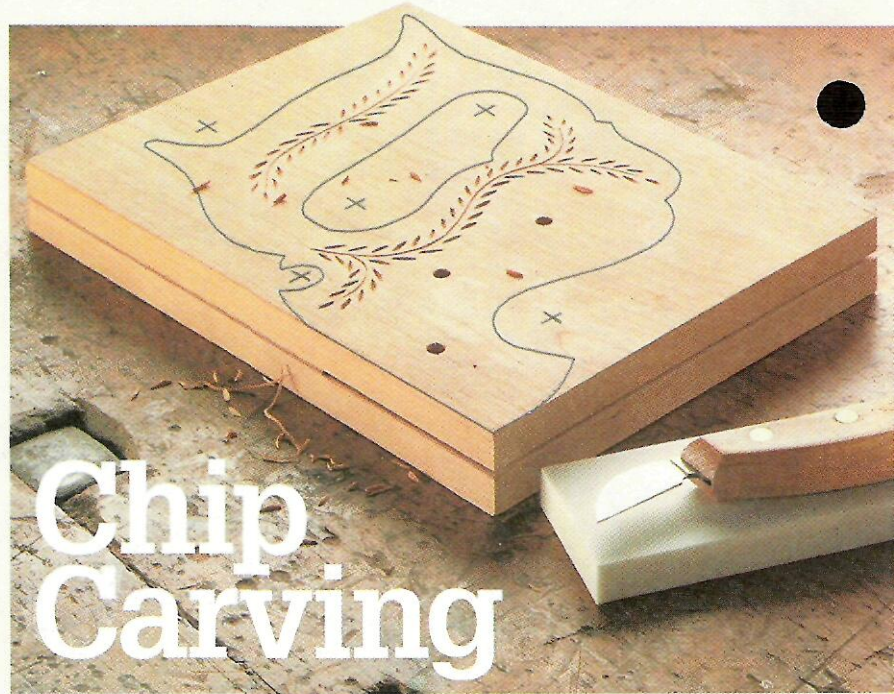

▲ **Carving Knife.** This short-bladed knife is all it takes to chip carve a simple wheat pattern. (Refer to page 31 for sources.)

To produce crisp, clean details, the cutting edge of the knife has to be razor shape. The nice thing about the blade on this knife is it's made of high-quality steel that takes a keen edge. (To learn how to sharpen the knife, turn to page 30.)

**Wood Selection** – After you've sharpened the knife, it's a good idea to practice on some scrap pieces of wood before carving the saw handle. Typically, a softwood like basswood is

used for chip carving. But basswood is too soft for a saw handle. So it's best to practice the carving techniques in the same type of wood that you plan to use for the handle. (I made the handle out of cherry.)

**Transfer Pattern** – Regardless of the type of wood you use, you'll have to transfer the wheat pattern to the upper blank used to make the handle. For a simple way to do this, see the box at the lower left.

## Transferring the Pattern

One of the easiest ways to transfer a pattern to a workpiece is to use a tissue-thin paper called *transfer paper* (shown at left).

Transfer paper works like carbon paper, only better.

Instead of leaving a waxy, greasy residue, it leaves "dry" lines that are easy to erase.

To transfer the wheat pattern for this carving, first tape a full-size photocopy of it to the upper blank for the handle. Note: The pattern is shown on page 25. Then slip the transfer paper between the pattern and the wood with the dark side down. (See photo at right.)

Now simply trace the pattern with a pencil.

The transfer paper leaves a light line wherever you push down with a pencil. (Transfer paper is available from many art stores or from the source listed on page 31.)

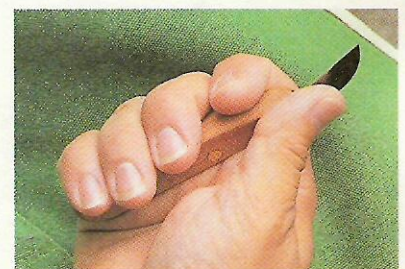
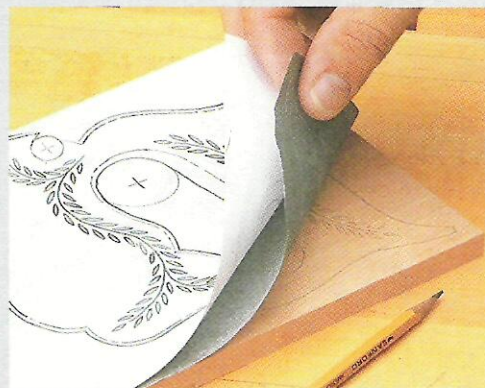

▲ **Grip.** After placing the carving knife in your hand (top), wrap your fingers around it and hold your thumb against the handle (bottom).



**Get a Grip** – One of the secrets to mastering chip carving is learning how to hold the knife. As you can see in photo ‘A’ on page 28, the idea is to place the knife (cutting edge up) in your hand so it’s resting at the base of your fingers. Then wrap your fingers around the handle. Pay special attention to the position of the first joint of your thumb. To provide support as you make a cut, it should be even with the *blade end* of the handle (Photo ‘B’).

**Tripod** – But your thumb only offers *one* point of support. The goal is to form a stable tripod by creating *three* separate points of contact with the workpiece.

To do this, turn the inside of your wrist toward your body. Then rest the tip of your thumb, the knuckle of your index finger, and the point of the blade on the workpiece. This may feel awkward at first, but with practice, it will begin to feel more comfortable. In any case, it’s important to stick with it.

**Cutting Angle** – That’s because in this position, the blade is tilted at about a 65° angle to the workpiece, and this is the basic cutting angle for

chip carving. Shop Tip: You may want to use a scrap block as a guide to check the angle occasionally, as shown in the upper photo in the margin.

**Practice Cuts** – Now you’re ready to make a few practice cuts. The kernels of wheat are the easiest part of the pattern to carve. So draw a few kernels on a scrap piece and try them first. Shop Tip: To make it easier to carve hardwood, it’s a good idea to “soften” the wood fibers. (See lower photo in margin.)

There’s no need to clamp the workpiece to a bench, and it doesn’t even have to be held flat. In fact, I hold it in my lap like a notebook. This makes it easy to shift the piece around to find a more comfortable position or work in a tight spot.

To carve each chip, start by setting the tip of the blade at one end of a kernel. Then poke the blade into the wood and *pull* the knife toward you, as shown in Figure 1. It’s tempting to draw the blade toward your thumb as if you’re peeling potatoes. But ideally, your hand and knife should move as a unit in a single, smooth motion. Also, keep your elbow close to your body to

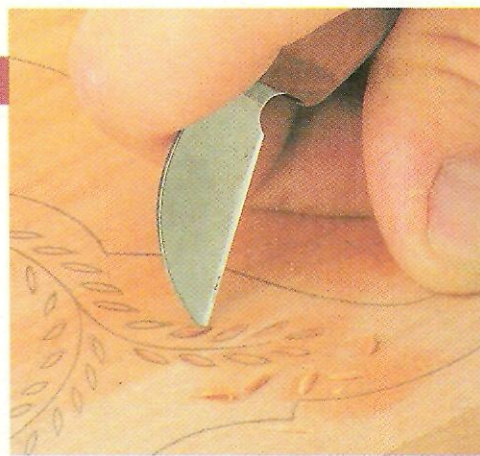

▲ **Kernels.** To carve each kernel of wheat, push the tip of the blade into the wood and make two slicing cuts to remove a small chip.

provide more leverage and control.

**V-Groove** – As the blade slices into the wood, it creates the *first* part of an angled cut that will eventually form a V-shaped groove (Figure 1a). That’s the easy part. The trick is to make a *second* cut that meets it at the bottom of the groove and “pops” the chip out of the wood (Figure 2a).

The key to producing a crisp, clean kernel is to make each cut the same depth. The wider the chip, the deeper the cut. Also, to avoid leaving a rough surface, try not to go back over a cut you’ve already made.

**Cutting Sequence** – I know, it sounds like there’s a lot to keep track of. But it only takes awhile to develop a knack for it, especially if you follow a basic cutting sequence. Start by carving *one* side of *all* the kernels (Figure 1). Then turn the workpiece end for end and cut the *second* side of each kernel (Figure 2).

Using this sequence, you can make each cut without changing your *hand position or the angle* of the blade. Plus it helps establish a rhythm that makes carving the kernels as easy as eating popcorn.

**Carve the Handle** – Once you’re satisfied with the results, it’s time to carve the “real” handle. So settle down in a comfortable chair, take your time, and start carving the individual kernels. (See photo above.)

As you work, don’t worry if each kernel is perfect, or if you cut outside the lines. In fact, if the kernels are like mine, each one is just a bit different. But that’s okay. It’s all part of the beauty of chip carving.

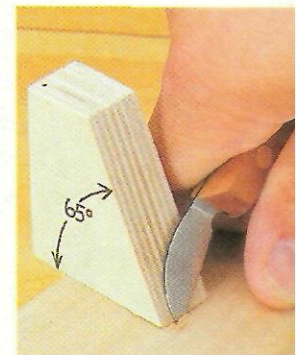

▲ A scrap block cut to a 65° angle provides a handy reminder of the correct cutting angle of the blade.

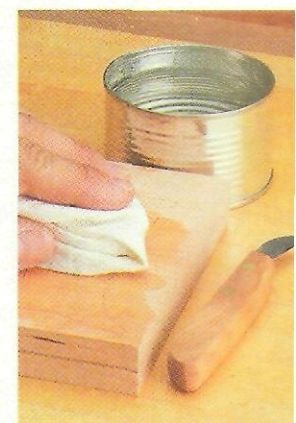

▲ To make it easier to carve hardwood, dampen the surface with water to soften the wood fibers.

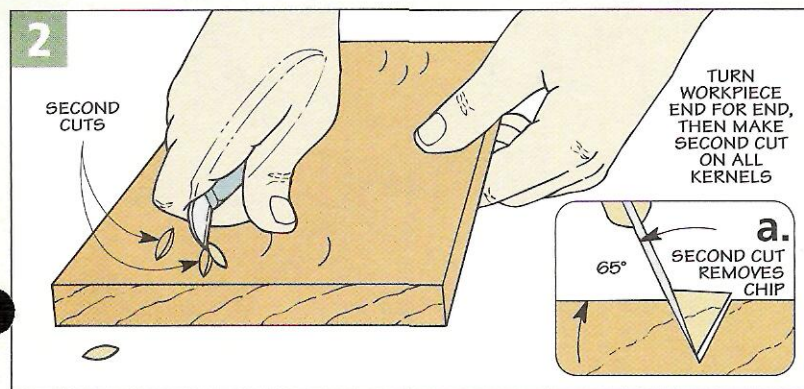
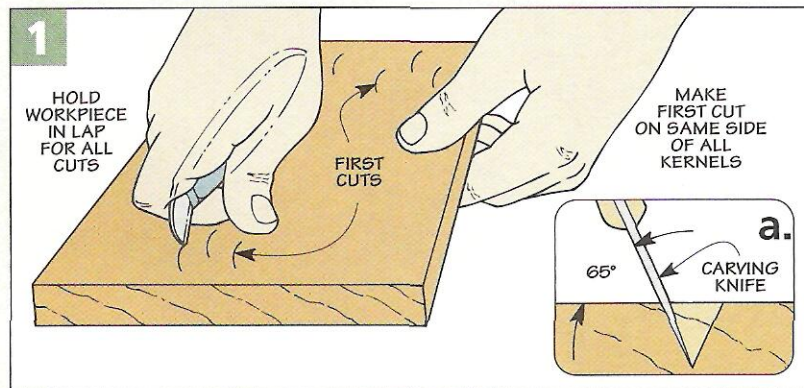



## Carving the Stems

The second part of the carving is the graceful, curved stems that run between the kernels. Carving a stem isn't all that different from a kernel.

Here again, the grip and the angle of the blade are the same. And as before, two slicing cuts form a V-shaped groove. The first cut defines the curved shape of the stem. Then, after turning the workpiece end for end, the second cut removes a thin ribbon of wood. (See photo at right.)

**Depth of Cut** – As with the kernels, the goal is to make both cuts the same depth. But since the stems are quite narrow, you'll only need to carve about  $\frac{1}{16}$ " deep into the wood.

**Look Ahead** – As you make each cut, the idea is to look *ahead* of where the blade is cutting. This will make it easier to follow the line and create a smooth, flowing shape.

**Tight Curves** – One area that may cause problems is the tight curves. As you pull the knife around the curve, the blade may start to "drag" a bit.

As you can see in Figure 3, the solution is to raise the handle slightly as you work into a tight curve. This way, only a small portion of the cutting edge is buried in the wood, so it's easy to carve a continuous curved line.

**Valleys** – The "valleys" where two stems come together also need special attention. That's because the triangular area in between may chip out.

To prevent that, I carve the main stem first. Then I plan the sequence of cuts for each short stem as shown in the detail below. The key here is

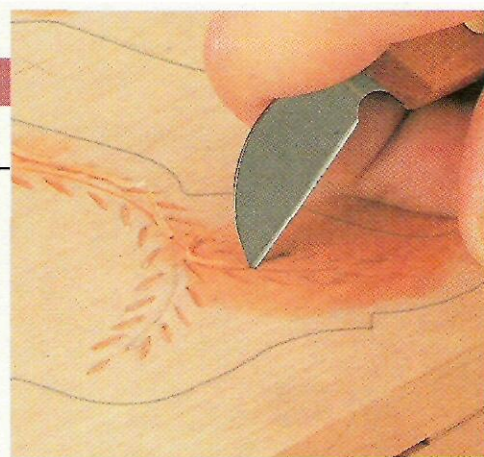

▲ **Stem.** When carving the curved stems of the wheat pattern, the idea is to make two slicing cuts to remove a thin ribbon of wood.

the orientation of the blade where the *first* cut meets the main stem. Ideally, you want the cutting edge of the blade to point *away* from the main stem. Note: Depending on which side the short stem is on, the first cut may start or end at the main stem.

**Final Details** – After completing the stems, just erase any pencil marks and lightly sand the carving. 🛠️

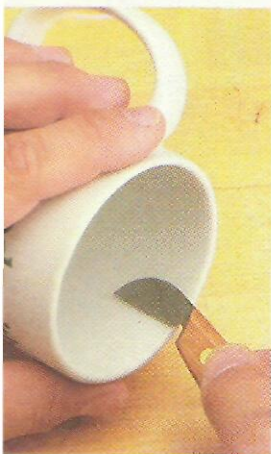

▲ To touch up the edge of a carving knife, run it around the inside of a ceramic coffee cup.

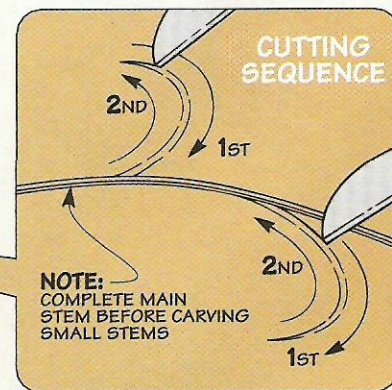
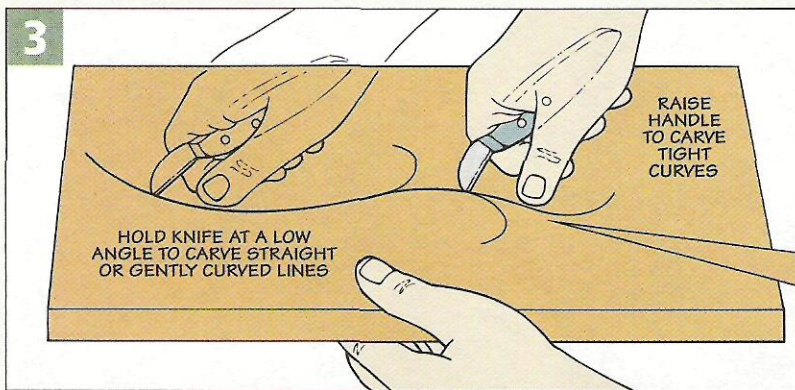

## Sharpening the Blade

It only takes a few minutes to sharpen the blade on the carving knife.

**Start with the Bevel** – On my knife, there's a  $10^\circ$  bevel on both sides of the blade. So I try to maintain this angle as I'm sharpening. An easy way to determine this angle is to set the blade on a sharpening stone and then place a dime under the back of the blade, as shown in the detail at right. Note: I use a medium-grit ceramic stone. (For sources, see page 31.)

Once the angle is established, slide the blade back and forth on the

stone, applying even pressure along the entire length of the bevel, as shown at right. You'll want to count the number of strokes here. Then repeat the process on the other side using the same number of strokes. This ensures that the same amount of material is removed from both sides.

**Hone the Bevels** – Now it's just a matter of honing the bevels. To do this, I switch to an ultra-fine grit stone and use the same procedure to create a razor-sharp edge. Note: In a pinch, try the tip shown in the margin.

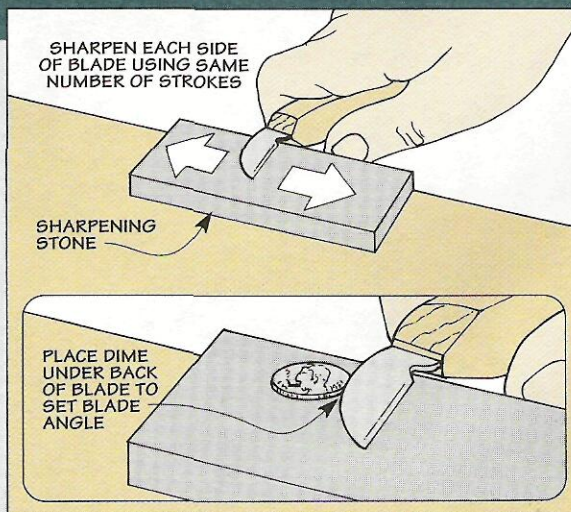



# Sources

## PRODUCT INFORMATION

## MAIL ORDER SOURCES

### Hardware & Supplies

To make it easy to round up the hardware and supplies that you'll need to build the projects featured in this issue, we've put together a number of convenient mail-order sources.

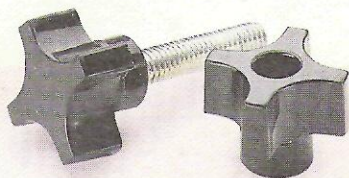

### ▲ Star Knobs

The Radial Arm Saw Miter Jig (page 6) uses two different types of plastic "star" knobs to lock parts of the jig in place. One knob (shown at left) has a  $\frac{5}{16}$ " threaded stud that's  $1\frac{1}{2}$ " long. The other has a  $\frac{5}{16}$ " threaded thru-hole (right). A source of knobs is listed in the margin.

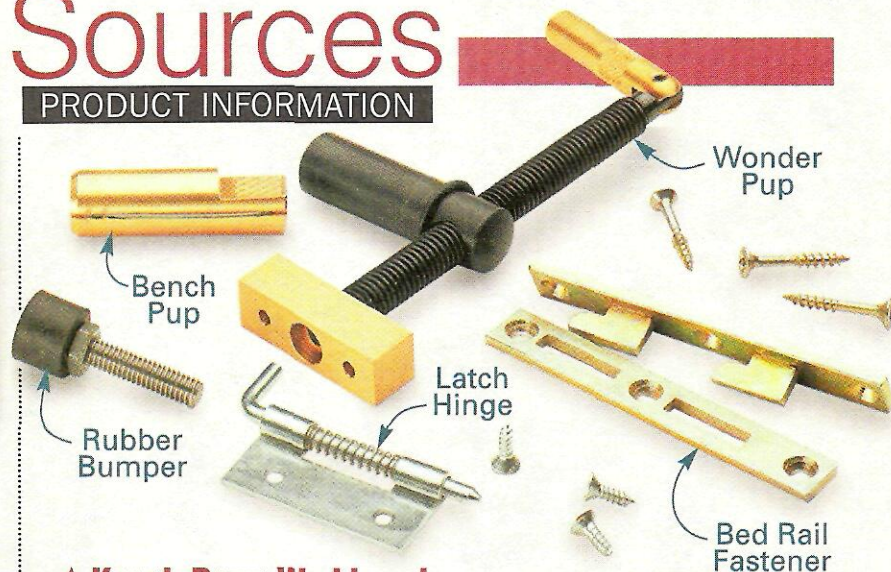

### ▲ Knock-Down Workbench

The Knock-Down Workbench featured on page 16 makes an ideal, general-purpose bench for working on projects around the house. Plus it "knocks down" for storage.

To assemble the workbench (and take it apart), we used the same type of hardware that's used to join the rails on a bed to the headboard and footboard. These 4" bed rail fasteners are available in sets of four from the sources listed at right.

There are also several other pieces of hardware that you'll need. The rubber bumpers (Part No. 9546K18) that act as the "feet" of the bench, and the latch hinges (Part No. 1305A38) that secure the top are available from McMaster-Carr. To clamp a workpiece against the benchtop, we purchased two pairs of bench dogs from Lee Valley called *Bench Pups* (05G04.04) and *Wonder Pups* (05G10.02).

**Ballew**  
800-288-7483  
*Amana Saw Blades*

**Lee Valley Tools**  
800-871-8158  
*Bench Pups,  
Wonder Pups*

**McMaster-Carr**  
800-871-8158  
*Rubber Bumpers,  
Latch Hinges*

**Rockler**  
800-279-4441  
*Bed Rail Fasteners*

**Woodcraft**  
800-225-1153  
*Carving Knife,  
Sharpening Stones*

**Woodsmith Store**  
800-835-5084  
*Bed Rail Fasteners,  
Carving Knife,  
Sharpening Stones,  
Star Knobs*



### ▲ Carving Knife & Sharpening Stones

All it takes to create a simple chip carving (like the wheat pattern shown on page 28), is a single carving knife. The knife I use has a comfortably-shaped handle and a fine steel blade.

Getting a razor-sharp edge on the blade of the carving knife is easy with a set of two ceramic sharpening stones. I use a medium-grit stone (the gray stone above) to shape the bevel and an ultra-fine grit stone (white) for polishing it to a mirror finish. Sources for the knife and stones are listed in the margin.

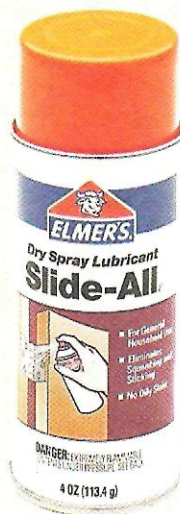

### ▲ Dry Lubricant

To keep your radial arm saw running in top condition, it needs to be lubricated from time to time.

But oily lubricants often attract dust and create a gooey mess. To avoid this, it's best to use a "dry" spray lubricant as shown above. Dry lubricants are available at many hardware and auto parts stores as well as home centers.

### Radial Arm Saw Blade

In the article on page 12, we provide a simple tune-up procedure for a radial arm saw. In addition, you may want to consider getting a blade that's specially designed for making clean, smooth crosscuts on a radial arm saw.

This 72-tooth carbide-tipped blade has an *alternate top bevel* grind. Each tooth removes only very small chips, so the blade produces a very high-quality finish.

Another advantage to this blade is the teeth have a  $0^\circ$  hook angle (forward lean). This prevents the blade from "grabbing" or running through the piece being cut. A source of this blade (Part No. 610720) is listed in the margin.

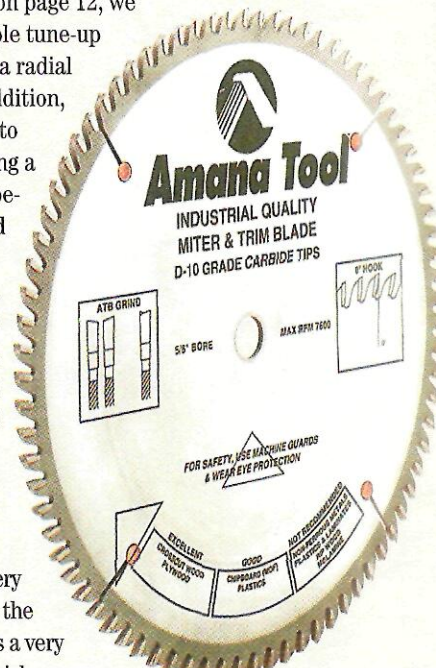

### ON-LINE CUSTOMER SERVICE

- Access information about your subscription account.
- Find out if your payment has been received.
- Change your mailing address or your email address.
- Renew your subscription.
- Pay your bill.

[www.ShopNotes.com](http://www.ShopNotes.com)

### WoodNet

- 101 Woodworking Tips Online
- Woodworking Techniques
- Project plans you can download
- WoodNet Forum
- Power Tool Reviews

[www.AugustHome.com](http://www.AugustHome.com)



## Scenes from the Shop

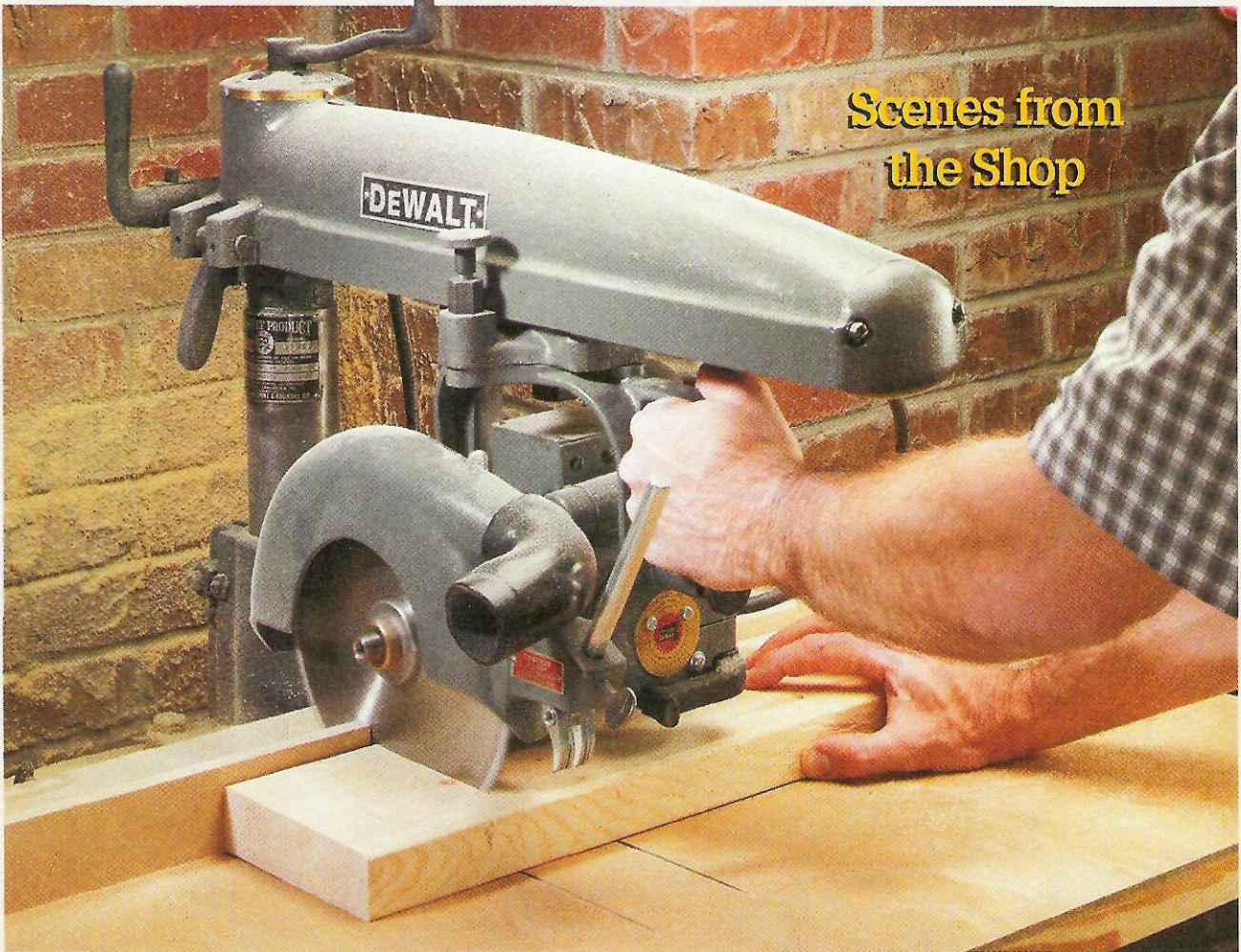

▲ Manufactured in 1939, this DeWalt radial arm saw is a real workhorse that has provided over sixty years of reliable service. Recently, it was completely restored and tuned up

by a company that specializes in bringing old radial arm saws back to life. For more information, you can contact Wolfe Machinery Company by calling 800-345-6659.



▲ Whether you tilt the head of the saw to make a bevel cut (left) or rotate it 90° to rip a board (right), this saw produces smooth, accurate cuts every time. With precision ball



bearings housed in its cast iron arm, a heavy-duty crank to raise and lower the blade, and thick, beefy adjustment levers, this saw should provide useful service for decades to come.