

SHOP LAYOUT
SECRETS
From a Master
Craftsman

SPECIAL ISSUE: PORTABLE POWER TOOLS

ShopNotes®

Vol. 9

Issue 54

POWER TOOL CART

Roll-around storage
in a custom cabinet

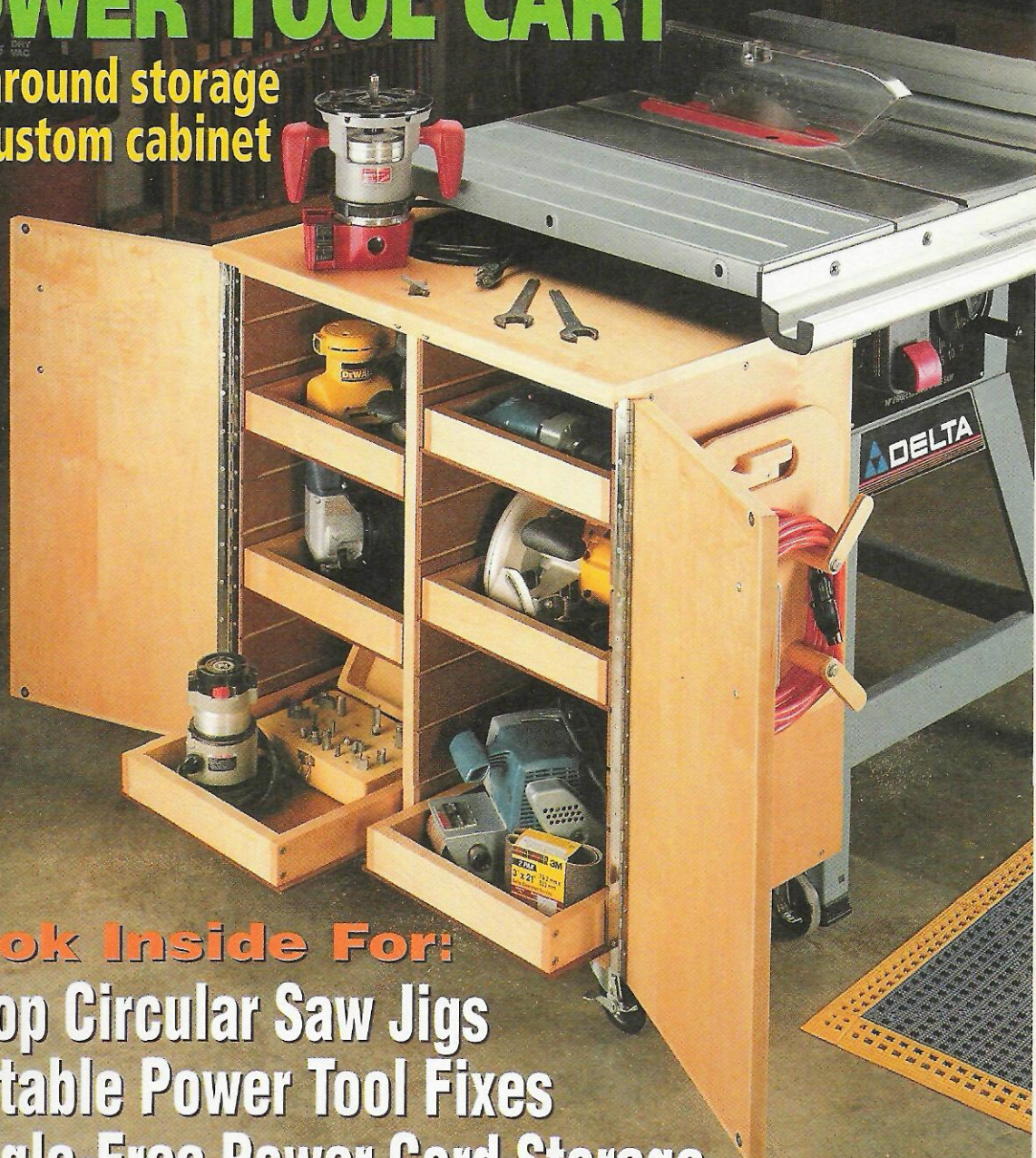

Look Inside For:

- ◆ 5 Top Circular Saw Jigs
- ◆ Portable Power Tool Fixes
- ◆ Tangle-Free Power Cord Storage



ShopNotes®

Issue 54

November 2000

PUBLISHER Donald B. Peschke
EDITOR Tim Robertson
ASSOCIATE EDITOR Bryan Nelson
CONTRIBUTING EDITOR Joel Hess
ART DIRECTOR Cary Christensen
SR. GRAPHIC DESIGNER Kurt Schultz
SENIOR ILLUSTRATORS Roger Reiland
 Mark Higdon

CREATIVE RESOURCES

Creative Director: Ted Kralicek • *Project Developer:* Ken Munkel • *Project Coordinator:* Kent Welsh • *Shop Manager:* Steve Curtis • *Shop Craftsman:* Steve Johnson • *Senior Photographer:* Crayola England

SPECIAL PUBLICATIONS

Executive Editor: Douglas L. Hicks • *Sr. Graphic Designer:* Chris Glowacki • *Graphic Designers:* Vu Nguyen, April W. Janning, Stacey L. Krull • *Asst. Editors:* Craig Ruegsegger, Joel A. Hess

CIRCULATION

Subscription Services Director: Sandy Baum • *Circulation Marketing Analysts:* Kris Schlemmer, Paula DeMatteis • *Renewal Manager:* Paige Rogers • *Sr. Graphic Designers:* Mark Hayes, Robin Dowdell • *Billing & Collections Mgr.:* Rebecca Cunningham • *Prom. Mgr.:* Rick Jankins • *New Bus. Mgr.:* Todd L. Bierle • *Asst. Sub. Mgr.:* Joy Krause

CORPORATE SERVICES

Director of Finance: Mary Scheve • *Controllor:* Robin Hutchinson • *Sr. Accountant:* Laura Thomas • *Accounts Payable:* Mary Schultz • *Accounts Receivable:* Margo Petrus • *Prod. Dir.:* George Chmielarz • *Electronic Pub. Dir.:* Douglas M. Lidster • *Network Admin.:* Cris Schwanebeck • *Pre-Press Image Specialists:* Troy Clark, Minnette Johnson • *Prod. Coordinator:* Noelle Carroll • *New Media Mgr.:* Gordon C. Gaippe • *Multimedia Art Dir.:* Eugene Pedersen • *Technology Analyst:* Carol Schoeppler • *Web Site Product Specialist:* Adam Best • *Web Content Mgrs.:* Terry Walker, David Briggs • *H. R. Asst.:* Kirsten Koele • *Facilities Mgr.:* Julia Fish • *Receptionist:* Jeanne Johnson • *Mail Room Clerk:* Lou Webber

MAIL ORDER

Operations Director: Bob Baker • *Customer Service Manager:* Jennie Enos • *Warehouse Supr.:* Nancy Johnson • *Buyer:* Linda Jones • *Admin. Asst.:* Nancy Downey • *Tech. Rep.:* John Audette • *Cust. Serv. Reps.:* Anna Cox, Tammy Truckenbrod, Deborah Rich, April Revell, Jeanette Rankin • *Warehouse:* Sylvia Carey, Dan Spidle, Sheryl Knox

WOODSMITH STORE

Manager: Dave Larson • *Sales Staff:* Wendell Stone, Jim Barnett, Kathy Smith, Larry Morrison, Harold Cashman, Tim Thelen, Gregory Kauzlarich, Mark Johnson, Joe Kucera • *Office Manager:* Vicki Edwards

ShopNotes® (ISSN 1062-9696) is published bimonthly (Jan., March, May, July, Sept., Nov.) by August Home Publishing, 2200 Grand, Des Moines, IA 50312.

ShopNotes® is a registered trademark of August Home Publishing ©Copyright 2000 by August Home Publishing. All rights reserved.

Subscriptions: Single copy: \$4.95. One year subscription (6 issues), \$27.95. Canada/International add \$10 per year, U.S. funds.

Periodicals Postage Paid at Des Moines, IA and at additional mailing offices.

Postmaster: Send change of address to ShopNotes, P.O. Box 37103, Boone, IA 50037-2103.

Subscription Questions? Write to: ShopNotes Customer Service, P.O. Box 842, Des Moines, IA 50304-9961. Or call 1-800-333-5854, 8:00 am to 5:00 pm, Central Time, weekdays. FAX 515-283-0447

E-Mail: ShopNotes@shopnotes.com

Internet: http://www.shopnotes.com

PRINTED IN U.S.A.

EDITOR'S NOTE

Cutoffs

There's only one thing I like better than talking to other woodworkers about their shops — getting a chance to take a look at those shops firsthand. Lately, I had a chance to do just that.

If you recall, I mentioned that we'd been planning to visit a number of other woodworkers' shops. The idea was to take a peek at all kinds of shops, and then feature some of the highlights in future issues of ShopNotes.

So to get the ball rolling, I asked readers to send in snapshots of their shops. What started out as a trickle of these "shop shots" soon turned into a steady stream. (Take a look at a few of them up above.)

Not surprisingly, there were lots of interesting shops — everything from an old cistern that had been converted into a small shop to a free-standing building with enough space to hold a barn dance.

Every day, there were new shops to look at with all sorts of innovative ideas. And I've got to admit, I haven't anticipated the next day's mail this much since the time I sent for my secret decoder ring as a kid. Which got me to thinking. Why not give a "sneak peek" of some of these shops to our readers?

Shop Tours — The problem was how to do it. Up until recently, it wouldn't have been possible. But now, I had just the right "tool." If you take a look at the ShopNotes web site, you'll see that there are photos from three of the shops. So all it takes to tour these shops is to visit us at www.ShopNotes.com and then click on *Woodworking Shop Tours*.

While you're at it, you might want to consider sending a few photos of your own shop to post on the web. It's a great way to share information and ideas with other woodworkers. Note: All the details are on our web site.

In this Issue — But you don't have to have a computer or Internet access to take a guided shop tour. If you turn to page 28 of this issue, you'll see that there's a close-up look at a shop that belongs to a woodworker in Ohio by the name of George Reid.

No-Frills Shop — I had an opportunity to visit with George in his shop a while back. It's a fairly ordinary shop in the basement of an average home. The space is shared with the laundry facilities, a furnace, and a hot water heater. Not much different than a lot of basement shops, right?

But the intriguing thing is that in this modest shop, George builds some of the finest furniture I've seen — classic, 18th century-style furniture with intricate, hand-carved details. He even builds exact *miniatures* of his completed projects.

So in many ways, George's shop is just the *opposite* of his furniture. It's a basic, no-frills, get-the-job-done kind of shop. Yet it has everything he needs to produce fine, heirloom furniture.

Shop Profiles — Well, I hope you like "touring" George's shop as much as I did. It's the first in a series of Shop Profiles we're planning to offer. If you'd like to have your own shop featured (or know of someone with an interesting shop), drop me a line: Tim Robertson, 2200 Grand Ave., Des Moines, IA 50312.

Tim

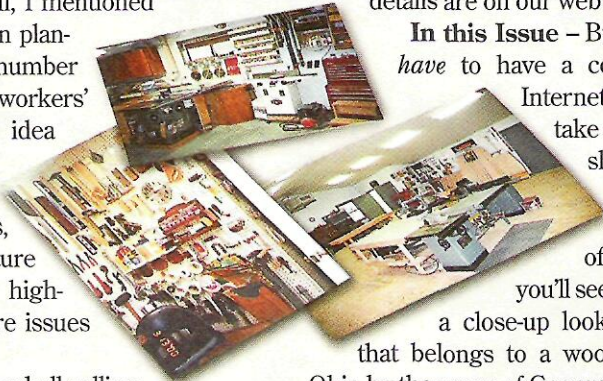

Contents

Features

Marking Gauge _____ 6

A traditional marking gauge — with a twist. Made of maple and brass, it features two ways to make precision layouts.

Power Tool Tune-Up _____ 12

If your portable power tools are running rough — or not running at all — there's usually an easy fix. Here are some practical tune-up tips for top notch performance.

Roll-Around Tool Cart _____ 16

Keep all your portable power tools right at hand with this roll-around cart. Adjustable trays help organize tools and accessories. Plus they can be customized to fit your tools.

5 Quick Circular Saw Jigs _____ 22

Who says a circular saw is only for rough carpentry work? These five great jigs will turn it into a precision tool.

Power Cord Caddies _____ 26

Untangling a power cord is a hassle. Here's a one-hour solution — a shop-made caddy that keeps it coiled. Also, plans for a simple cabinet that holds three caddies.

Heirlooms from a Basement Shop _____ 28

Extraordinary furniture from an ordinary shop. See how one woodworker creates classic heirlooms — in spite of the challenges of working in a basement shop.

Departments

Readers' Tips _____ 4

Our readers offer their own shop-tested tips dealing with some of the most common woodworking problems.

Sources _____ 31

Mail-order sources and supplies to help you build the projects featured in this issue.

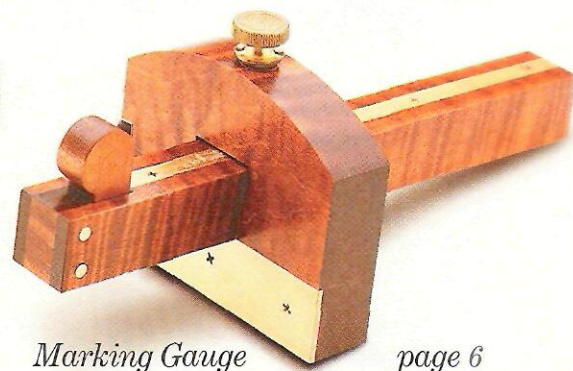

Marking Gauge page 6

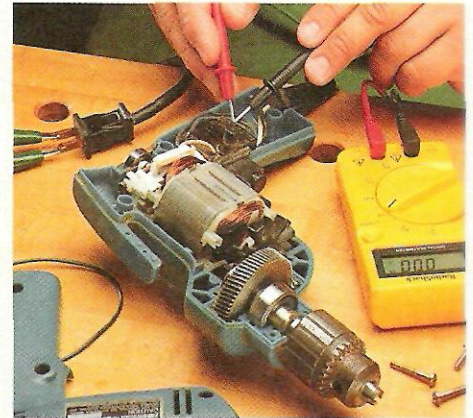

Power Tool Tune-Up page 12

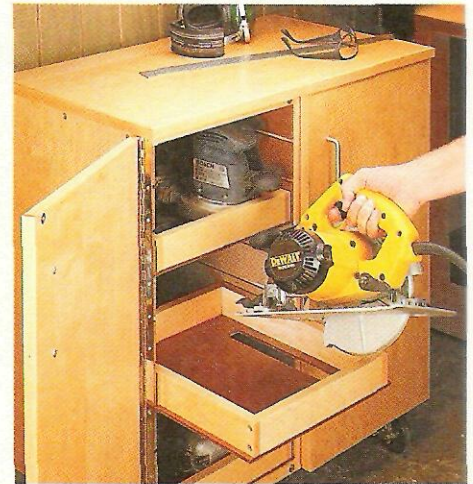

Roll-Around Tool Cart page 16



Power Cord Caddy page 26

Readers' Tips

Auxiliary Top

■ I built the knock-down workbench from *ShopNotes* No. 52, and it works great. To make it even more versatile, I added a large *auxiliary top* for working with oversize projects.

The *top* is a piece of $\frac{3}{4}$ " plywood "wrapped" with solid wood edging, as shown at right. To hold the top in position, two wood *cleats* fit down through the slots in the bench. After cutting these cleats to match the shape of the slots, they're screwed to the top.

To secure the top, I screwed a wood *turnbutton* to each cleat (*End View*). A quick twist of the turnbutton "locks" the top in place.

Walter Berbee
St. Paul, Minnesota

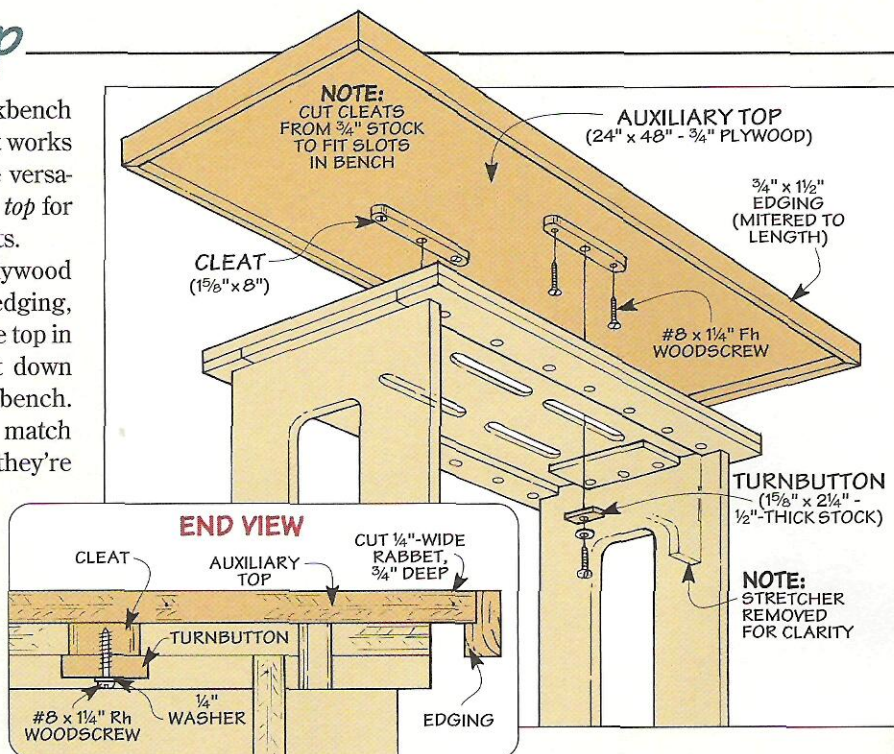

Free Tips ON THE WEB

Get more wood-working tips free.

Visit us on the Web at ShopNotes.com

Sign up to receive a free shop tip by email every week.

End-Matching Technique

■ Ordinarily, a box can be assembled so the grain runs around *three* corners. But there's a way to get the grain to continue around all *four* corners. It involves resawing both sides and ends of the box from a single piece of wood.

The key to this end-matching technique is how the pieces are cut from the board. Start with a piece

that's the desired length of one side and one end *plus* a single saw kerf. Then resaw the board to produce two pieces, as in Step 1 below.

Layout – After planing each piece to the same thickness, label an end and a side on the *resawn* face of each piece (Step 2). These will be the *outside* of the box. Now crosscut an end

and a side from each piece.

Miter Joints – For an end-matched box, I use a miter joint to keep the grain pattern continuous across the joint line (Step 3). For the best match, the miter cuts should just shave the ends of the pieces.

Jim Vrooman
Meridian, Idaho

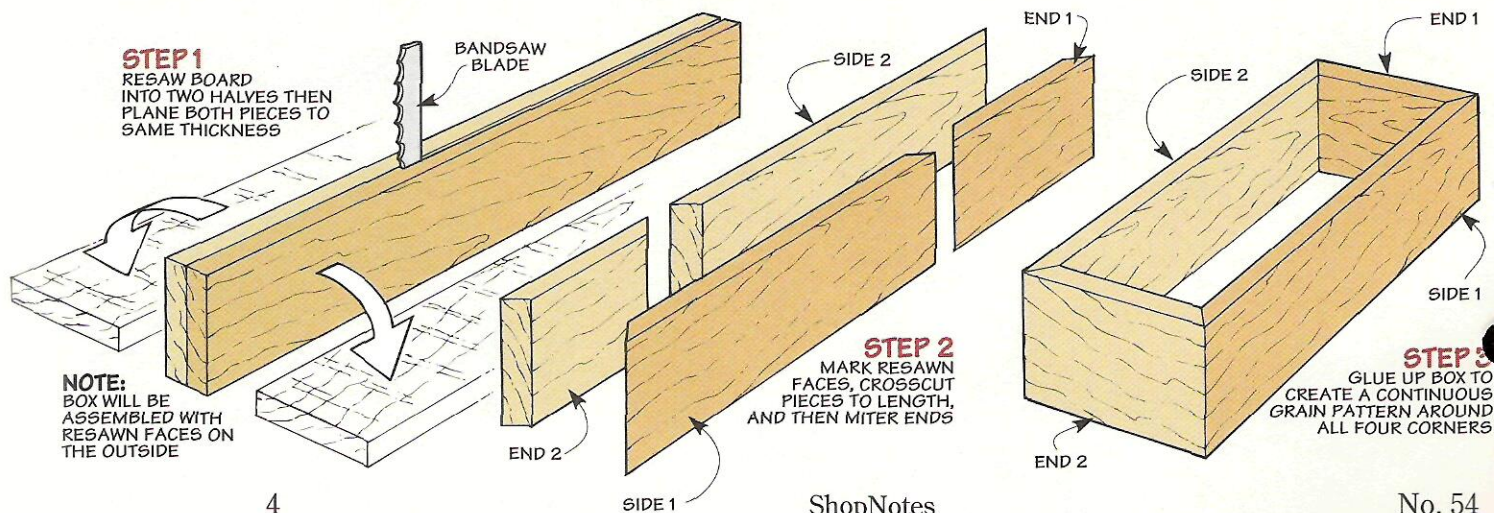

Quick Tips



▲ To prevent blades from knocking against each other and getting damaged, **Robert Stevens** of Lenox, MA uses a plastic lid as a spacer.

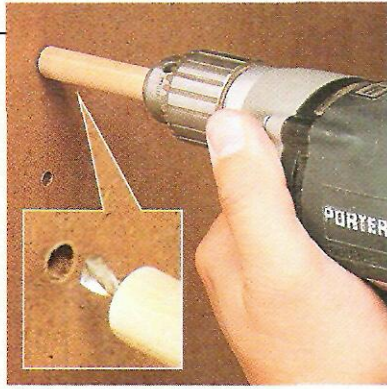

▲ Here's a handy depth stop. **Syed Hassan** of Timonium, MD slips a dowel onto a drill bit. The exposed part of the bit equals the hole depth.

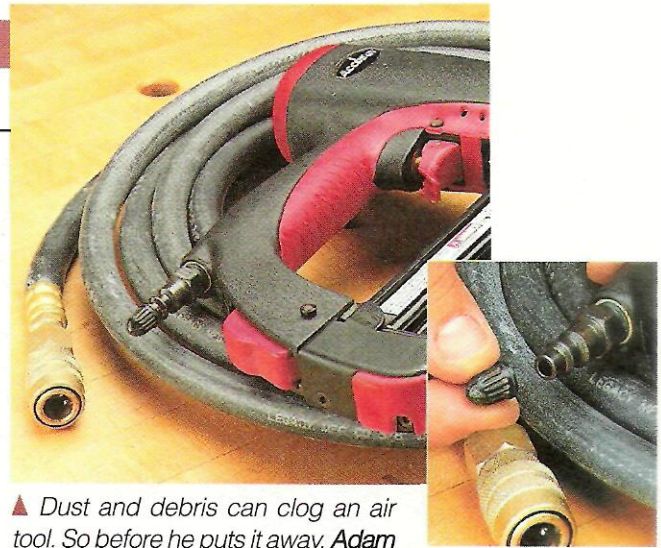

▲ Dust and debris can clog an air tool. So before he puts it away, **Adam Weinstock** of Mattoon, IL pushes a tire valve cap over the coupler plug.

Setup Tip

■ Here's a quick way to square up the miter gauge on a table saw.

Start by attaching a reference mark to the saw. (I use a piece of tape trimmed to a point.) Then hold a framing square against the miter gauge and slide it forward. (See drawings.) If the square aligns with the tape *all the way*, the miter gauge is set to make a perfectly square crosscut.

*Paul Stotler
Leonardtown, Maryland*

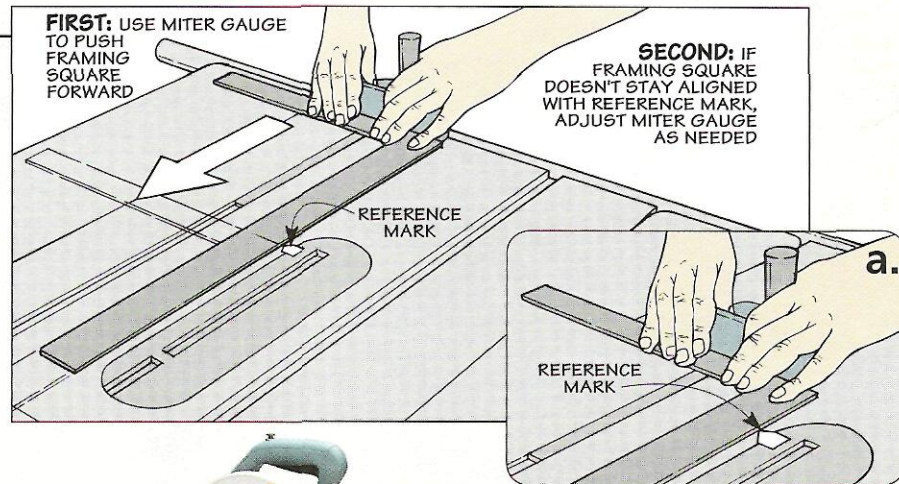

Miter Saw Tool Stand

■ When I saw the old, gas barbecue that my neighbor had thrown away, it gave me an idea. The metal frame of the barbecue would make a perfect roll-around tool stand for my miter saw.

All I had to do was remove the tank and grill, paint the metal frame, and then build a couple of table supports.

The miter saw is mounted to a $\frac{3}{4}$ " plywood base that's bolted to the frame. Two open-ended boxes serve as the table supports. (Just be sure they're flush with the surface of the miter saw table.) I even added a pull-out bin to hold short cutoff pieces.

*Charles Gipson
Lafayette, Indiana*



◀ When its grilling days are over, an old gas BBQ cart makes a handy, roll-around stand for a miter saw.

Send in Your Shop Tips

If you have a unique shop tip, we'd like to consider featuring it in one or more of our print or electronic publications.

We'll pay up to \$200 for a tip we publish. Just write down the tip and mail it to *ShopNotes*, Attn.: Readers' Tips, 2200 Grand Ave., Des Moines, IA 50312. Or FAX it to 515-282-6741, or send us an e-mail at shopnotes@shopnotes.com. Please include your name, address and daytime phone number in case we have any questions.

For accurate layouts, most marking gauges just don't "cut" it. This maple and brass hand tool does that — and more.

Call me old-fashioned, but I've always enjoyed the look and feel of a traditional, wood-bodied hand tool. Especially when it's dressed up with brass fittings.

In fact, that's one reason I decided to make the marking gauge shown in the photo at right. With a chunk of highly-figured maple that I'd "squirreled" away and a few pieces of brass hardware, I had all the makings for a great-looking hand tool.

Working with Brass – Well, that sounds fine. But isn't it difficult to fit the brass pieces to the wood? Actually, it's considerably easier than it looks. For a few tips that will help produce a flawless fit, take a look at the box on page 7.

Accurate Layouts – Of course, there's more to this hand tool than good looks. Like a traditional marking gauge, it provides a quick,

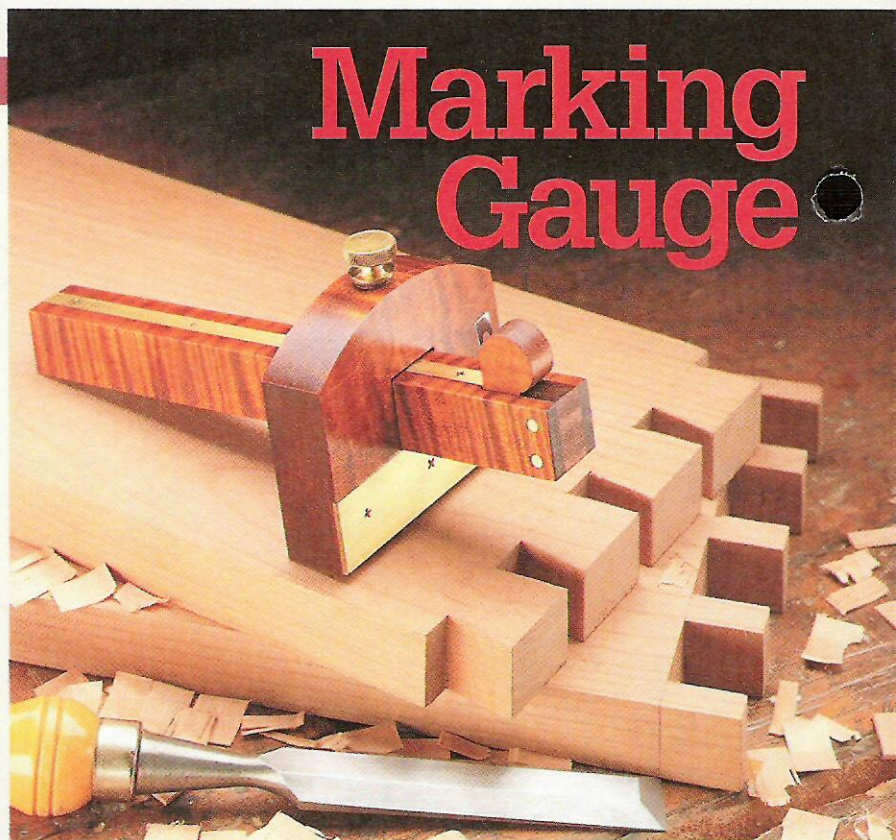

accurate way to draw a line or lay out the joinery for a project.

But what's different is *how* these lines are made. Instead of a sharp, metal pin, it's designed to mark lines using *two* different methods.

Drafting Lead – When working *with* the grain, a short piece of *drafting lead* is wedged into the beam of the marking gauge, as shown in photo A below. The nice thing about the lead is it doesn't

veer off and "follow" the grain like a metal pin. (I purchased drafting lead from an art supply store.)

X-ACTO Blade – To score a line *across* the grain, you can replace the lead with a *blade* that fits an X-ACTO knife (Photo B). Unlike the ragged line and torn fibers that are sometimes left by a metal pin, this blade severs the wood and makes a crisp, clean cut. Note: I picked up No. 24 blades from an art supply store.

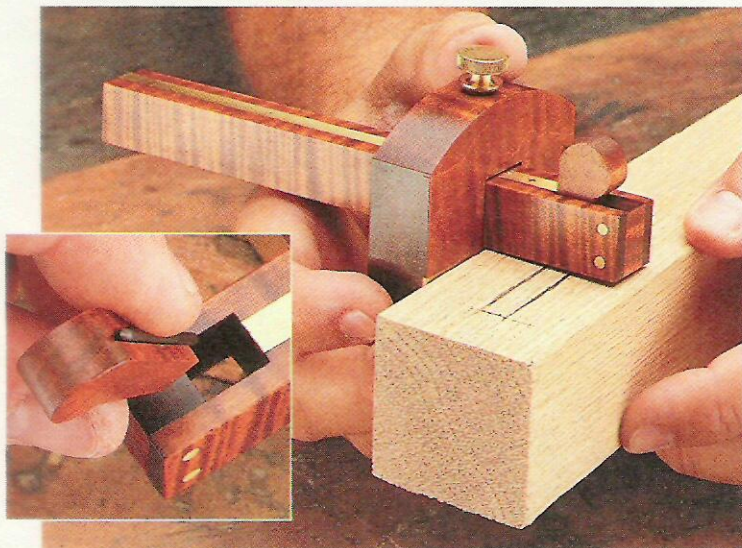

▲ **A. Drafting Lead.** With a short piece of drafting lead wedged into the opening in the marking gauge (inset photo), it's easy to draw an accurate layout line that won't "follow" the grain.

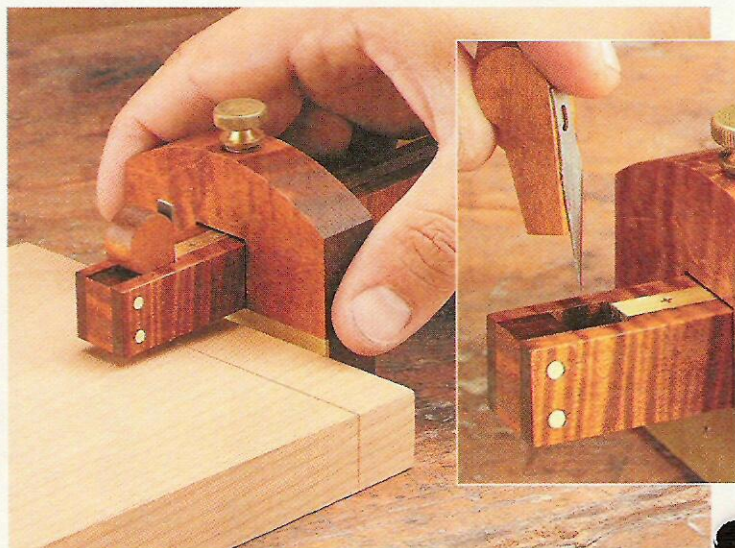

▲ **B. Blade.** To lay out a line across the grain, use the wedge to secure an X-ACTO blade in the marking gauge (inset photo). The blade scores a crisp, clean line without tearing the wood fibers.

Materials & Hardware

- A Fence (1) $\frac{3}{4} \times 2\frac{3}{8} - 3$
- B Beam (1) $\frac{3}{4} \times \frac{3}{4} - 6\frac{7}{8}$
- C Filler Block (1) $\frac{3}{8} \times \frac{5}{8}$ rgh. - $\frac{7}{8}$ rgh.
- D Wedge (1) $\frac{3}{8} \times \frac{5}{8} - 1\frac{9}{16}$

- (1) $\frac{3}{4} \times 3$ " Brass Plate ($\frac{1}{16}$ " thick)
- (7) #4 x $\frac{1}{2}$ " Fh Brass Woodscrews
- (1) $\frac{1}{4}$ "-20 Knurled Knob w/ $\frac{1}{2}$ "-long Stud
- (1) $\frac{1}{4}$ "-20 Brass Insert
- (1) $\frac{5}{16}$ "-dia. Shoe ($\frac{7}{16}$ " long)
- (1) $\frac{1}{4} \times 6$ " Brass Strip ($\frac{1}{16}$ " thick)
- (2) $\frac{1}{8}$ "-dia. Brass Rods ($\frac{3}{4}$ " long)

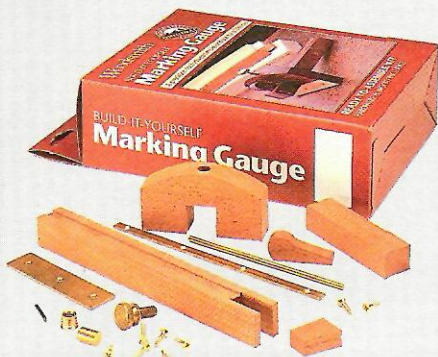

▲ **Ready-to-Assemble Kit.** If you'd like information about a complete, ready-to-assemble kit to build the marking gauge, please turn to page 31.

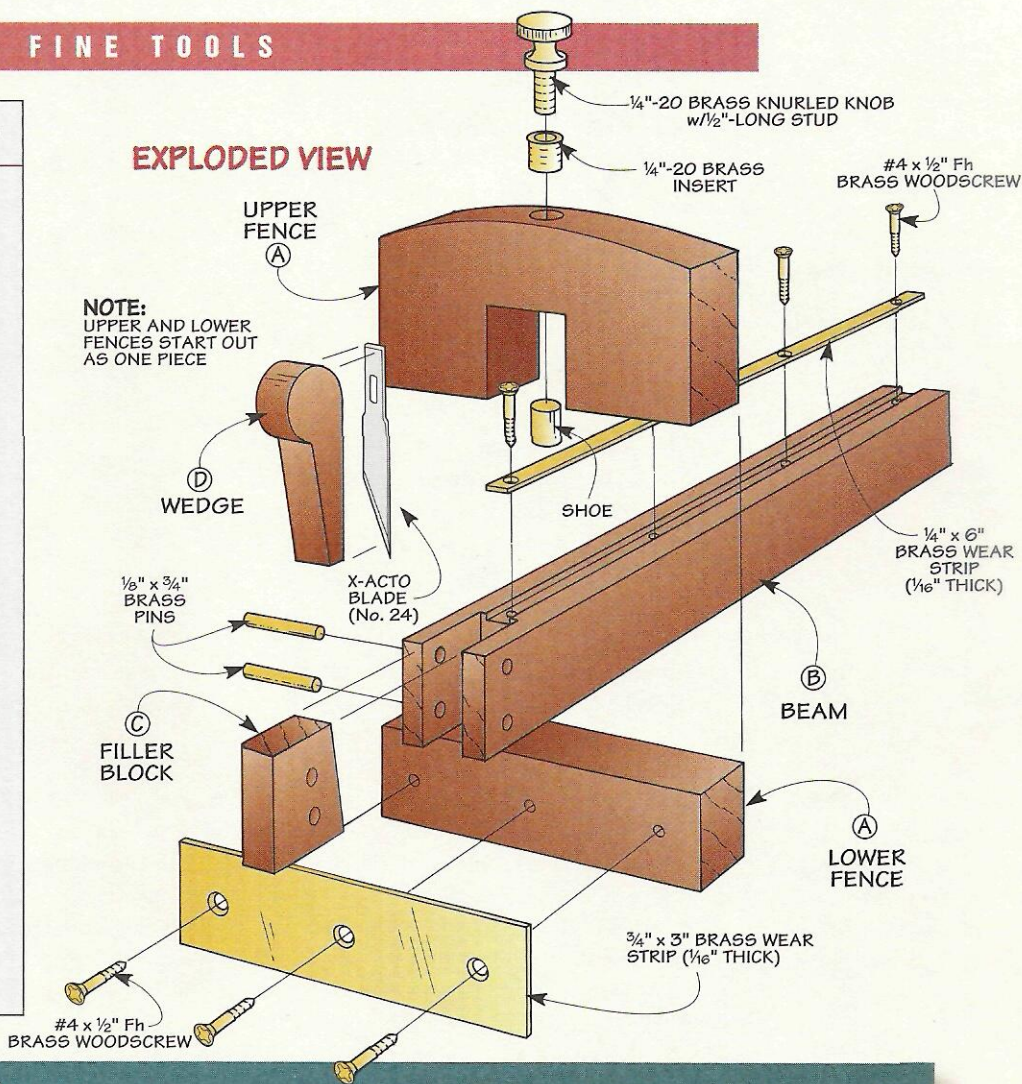

Working with Brass

It's not difficult to get the brass strips on the marking gauge to fit flawlessly. All it takes is a few simple techniques.

Cutting Brass – Brass is a relatively “soft” metal, so it's easy to cut with a hack saw. I cut the strips for the marking gauge $\frac{1}{32}$ " longer than needed and then sanded them flush after assembly.

Flat & Square – To get a good fit, the strip must be *flat* and *square*. The problem is the edges and ends get rounded over in the manufacturing process. So I sand the strips flat and file the ends square, as shown in Steps 1 and 2.

Countersink Bit – Another way to improve the appearance of the strips is

to make sure the mounting screws sit *flat* in the countersinks. To do that, I use a special bit with a single cutting flute that produces a smooth countersink (Step 3).

Note: This bit is manufactured by the *Weldon Company*. It's available from:

- *Woodcraft* 800-225-1153
- *Woodworker's Supply* . . . 800-645-9292

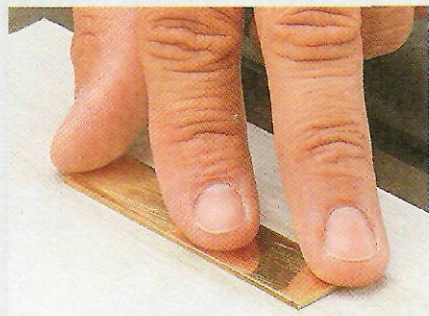

1 Flatten the Face – To flatten a brass strip, sand it on a piece of 120-grit sandpaper attached to a flat surface.

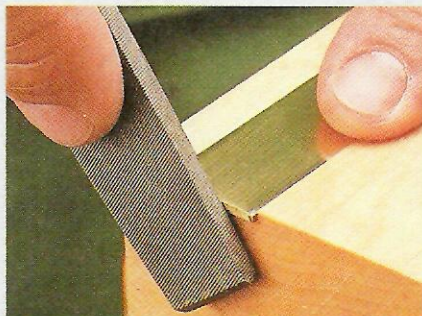

2 Square Ends – Using the end of a rabbeted block as a guide, square the ends of the strip with a smooth mill file.

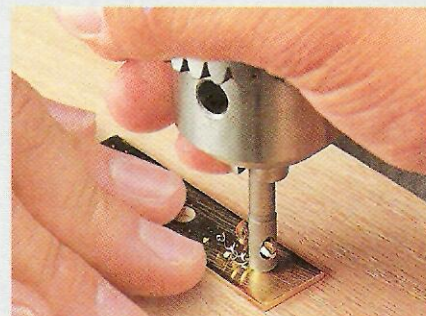

3 With a countersink bit mounted in the drill press, rotate the chuck by hand to produce a smooth surface.

Sliding Fence

I began by making a *fence* that slides along the beam of the marking gauge. The fence serves as a guide that rides against the workpiece. This ensures that the line that's marked ends up a uniform distance in from the edge (or end) of the board.

Two-Part Fence – If you look at Figure 1, you can see that the fence is made up of two parts: an *upper* and a *lower fence* piece. To create an opening that fits over the beam, the upper piece is notched. Then later, the two pieces are glued together to form the opening in the fence.

One thing to be aware of is these fence pieces are quite small. (Even when the fence is glued up, it's only about the size of a credit card.) That's too small to work with them safely on a table saw.

So as you can see in Figure 2, I started with an oversize blank of 3/4"-thick hardwood. It's a good idea to use a blank that's large enough for *both* fence pieces. That way, when they're glued together later, you'll be able to match the grain to create a joint line that's nearly invisible.

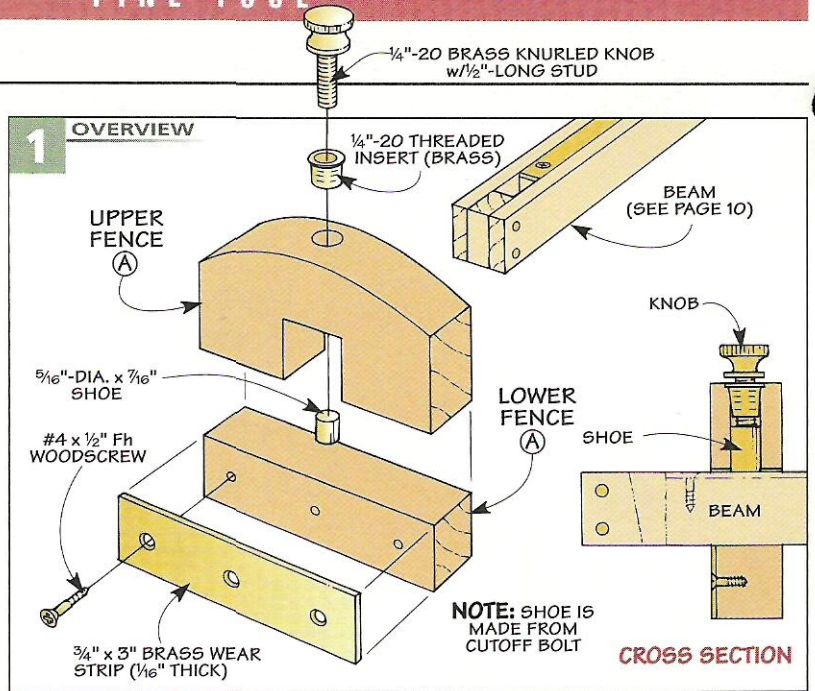

Rip a Strip – With blank in hand, the first step is to rip a narrow strip that will be used to make the *lower fence* (Figures 2 and 2a). You can set this strip aside for now. The remaining part is used to make the *upper fence*.

Layout – Start by laying out the length of the upper fence as well as the notch that will form the opening (Figures 2 and 2b). You'll also need

to draw a large arc near the top of the piece, as shown in the margin at left.

Cut Notch – Now you're ready to cut the notch. The table saw and a standard combination blade will make quick work of this. To prevent chipout on the back of the piece, it's best to attach an auxiliary fence to the miter gauge (Figure 2b). Then after raising the blade for a full-depth pass, make a series of cuts, nibbling away the waste to form the notch.

Drill Insert Hole – The next step is to drill a hole in the upper fence piece. A look at Figure 1 shows that this hole is sized to accept a threaded insert. (It's installed later in the top of the fence.)

The purpose of the insert is simple. When you tighten a knurled knob into the insert, it pushes a metal "shoe" against the beam of the marking gauge. (See Cross Section in Figure 1.) The downward pressure applied by the shoe holds the fence at the desired setting.

The hole for the insert (and shoe) is centered on the notch. To locate it accurately, you'll want to drill the hole from the *notched* side, not the top (Figure 3). It's also a good idea to use a backer board to prevent chipout when the bit breaks through.

Lower Fence – Before installing the insert, turn your attention to the

Shop Tip

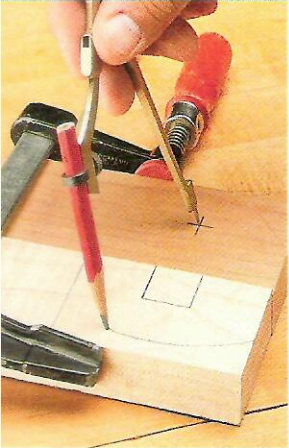

▲ A scrap block supports the tip of the compass when drawing the large arc on the upper fence piece.

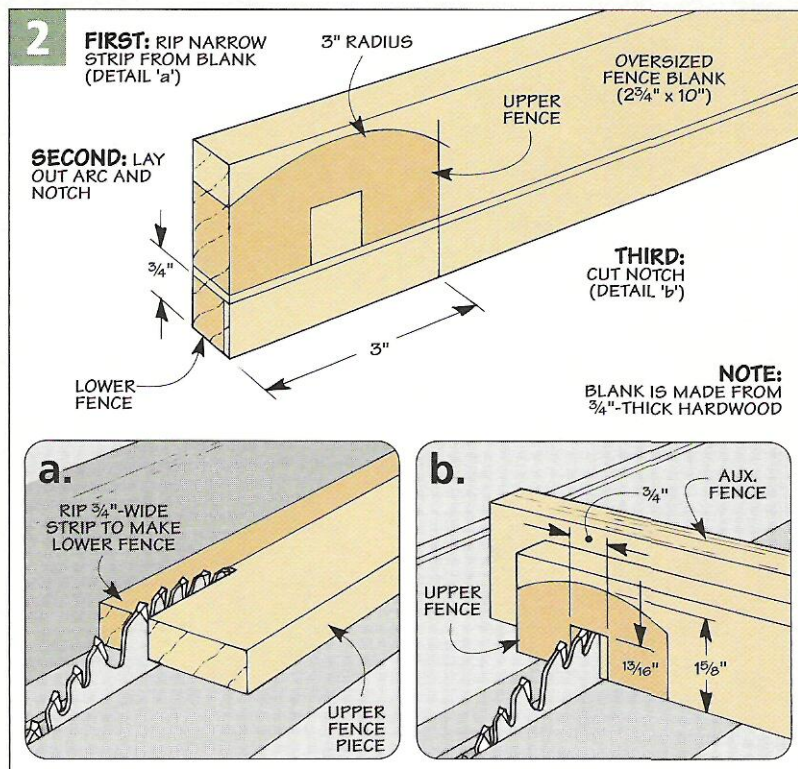

lower fence. Notice in Figure 1 that there's a brass strip attached to this piece. It creates a durable surface that resists wear. (Brass strips are available from most hobby stores.)

This wear strip fits in a shallow recess in the face of the fence. The goal is to end up with a recess that's just deep enough so the wear strip fits flush with the fence. This way, the fence will sit flat against a workpiece.

An easy way to accomplish that is to trim off the front edge of the lower fence (Figure 4). Just be sure that the amount of material removed equals the thickness of the brass strip ($1/16"$), as shown in Figure 4a.

Glue Up Fence – At this point, you're ready to edge-glue the two fence pieces together (Figure 5). Remember, to create a joint line that virtually disappears, orient the pieces exactly like they were before the lower strip was ripped from the blank.

Once the glue dries, there are just a few things left to complete the fence. But first, you'll need to crosscut it to final length. (I cut my fence 3" long.)

Cut to Shape – Next, to prevent the sharp corners of the fence from digging into my hand, I cut a gentle arc on the top edge (Figure 6). A band saw (or sabre saw) is all that's needed here. Either way, you'll want to stay about $1/16"$ to the waste side of the line.

Install Insert – After sanding the edge smooth, it's time to install the threaded insert in top of the fence. It fits down into the hole that

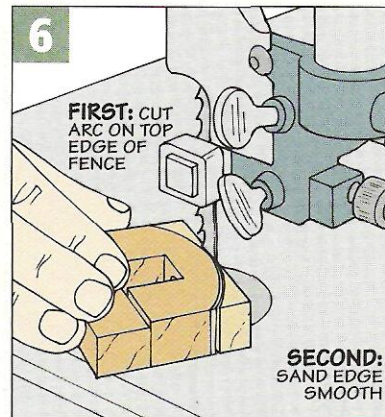
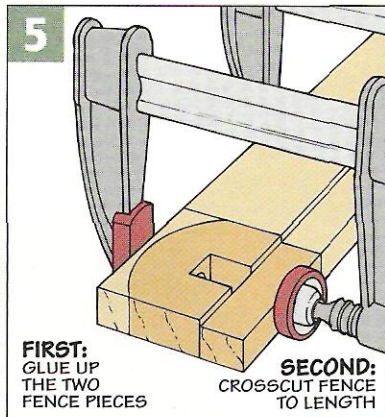
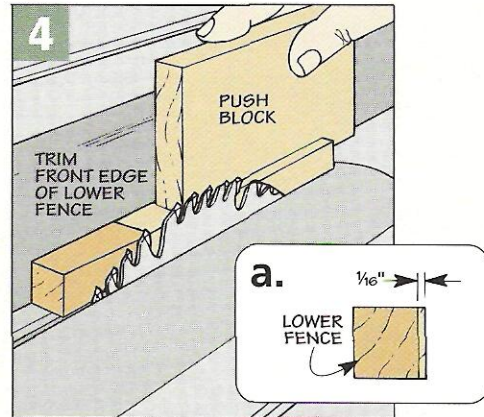
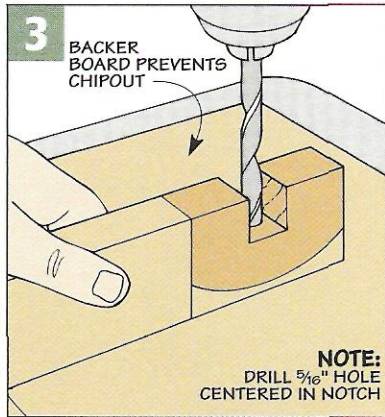

was drilled earlier. The important thing is to get it started straight in. What works well is to tap it lightly with a hammer. Then use a vise to slowly press the insert into place, as shown in Figure 7.

Notice in Figure 7a that the insert has a lip around the top that won't fit into the hole. It's not a big deal, but I wanted the insert flush with the top of the fence. Since the brass is quite soft, a sanding block makes short work of that (Figure 7b).

Attach Wear Strip – Attaching the brass wear strip takes a bit longer, but it's a fairly straightforward process. The information on working with brass (page 7) should help you get a good fit between the wear strip and the fence.

Start by cutting the wear strip to the same length as the fence. After sanding the strip flat and filing off any burrs, the next step is to drill countersunk shank holes for the mounting screws.

The thing to watch here is the depth of the countersinks. To create a nearly seamless fit, you want the screw heads to sit "proud," as shown in the margin. Then just file and sand them flush with the strip.

Install Knob & Shoe – All that's left to complete the fence is to add the knurled knob and shoe that are used to lock the fence. The knob threads into the insert in top of the fence (Figure 1). As for the shoe, I cut a short ($1/16"$) section from the smooth shank of a $5/16"$ -dia. bolt and stuck it in the hole.



▲ To create an almost invisible seam, drill the countersinks so the screw heads sit "proud" (upper photo). Then file and sand them flush (lower photo).

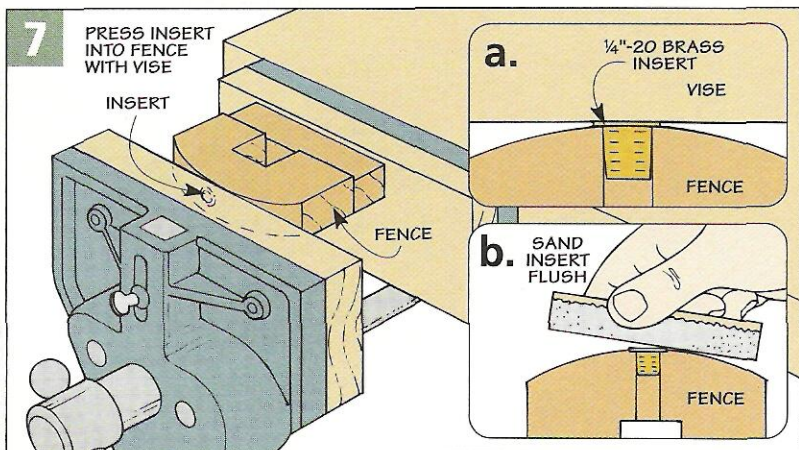

Beam

With the fence complete, I set about making the *beam*. This is a cigar-length, square block of wood that guides the fence as you slide it back and forth (Figure 8). A brass wear strip on top protects the surface of the beam when you tighten the fence. And an opening in the end houses a wood wedge that holds the lead (or blade) tightly in place.

On the Beam – As I mentioned, the *beam* (B) is a squared-up stick of wood. (I used maple.) To produce accurate results, it's important to get the beam to fit just right into the opening in the fence. If it's too tight, the fence is hard to slide. Too loose, and it wobbles from side to side.

Prepare Blank – The key to ending up with a perfect fit is to start by carefully preparing the wood blank used for the beam. Start by planing a board $\frac{3}{4}$ " thick and then ripping it to width to fit the opening in the fence. Then crosscut the *beam* (B) to final length. (I made a 7"-long beam.)

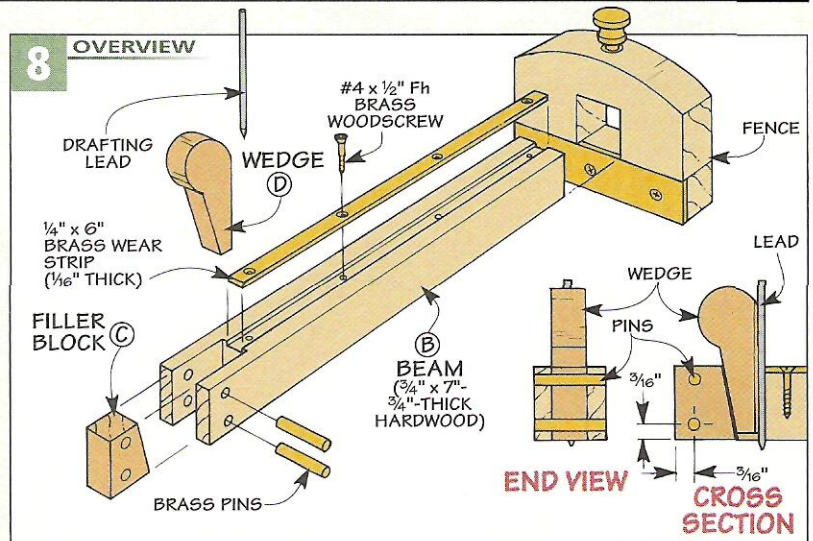

Wedge Opening – After squaring up the blank, the next step is to create an angled opening in the end of the beam that holds the wedge.

This is a simple two-step process. First, a notch is cut in the end of the beam (Figure 8). Second, a wedge-shaped block is added to “fill” the end of the notch.

Cut the Notch – A quick way to cut the notch is to use the table saw. This requires standing the beam *on end* to make a pass across the saw blade. So how do you keep it from tipping when making the cut?

The trick is to clamp the beam to a T-shaped support (Figure 9). With one piece of the support riding on the rip fence and the other backing up the workpiece, it's easy to hold the beam steady when making a cut.

Start by raising the saw blade to a height of $\frac{7}{8}$ " (Figure 9a). Then set the rip fence so the blade is *roughly* centered on the beam. Now make two passes, flipping the workpiece around for the second pass (Figure 9b).

This will produce a centered notch, but it needs to be a bit wider. So just nudge the fence away from the blade and make two more passes to end up with a $\frac{3}{8}$ "-wide notch.

Wear Strip – The next step is to add the brass wear strip. If you look at Figure 8, you can see that this wear strip fits in a shallow groove in the top of the beam.

Here again, the idea is to make the strip fit *flush* with the beam. As before, I used a $\frac{1}{16}$ "-thick strip. Only this time, it's $\frac{1}{4}$ " wide. So I adjusted the blade on the table saw to make a $\frac{1}{16}$ "-deep cut. Then I used the same two-pass method as before to center the groove (Figures 10 and 10a).

Start by setting the fence so the

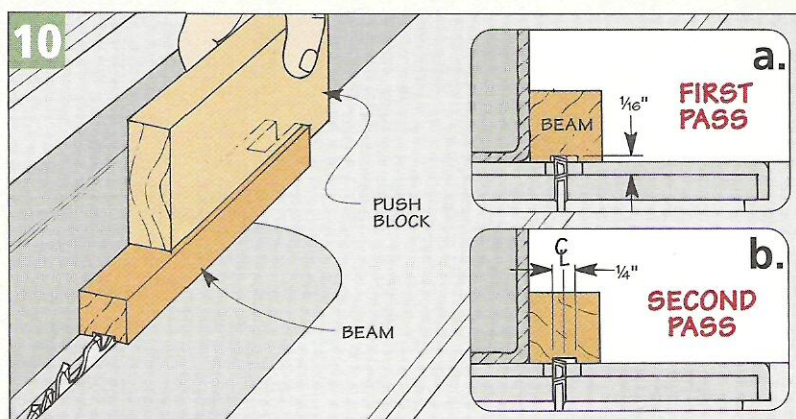
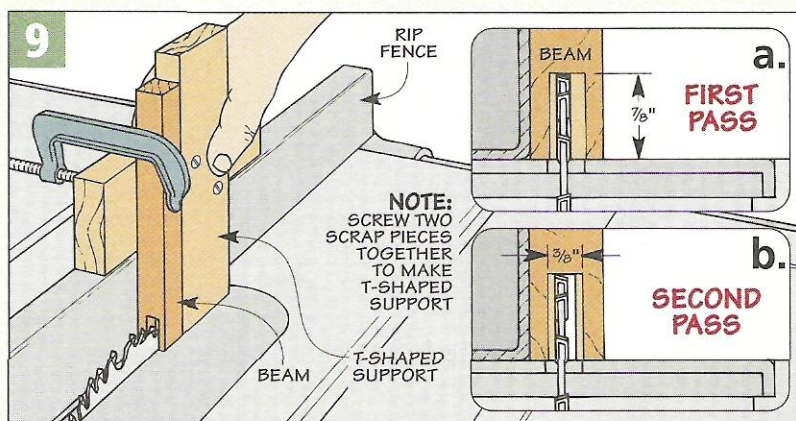

blade is roughly centered on the beam. Then make two passes, turning the workpiece end for end between each one. If necessary, repeat the process until the strip fits (Figure 10b). Then just screw the strip in place as before.

FILLER BLOCK & WEDGE

All that's left is to add two small pieces: a *filler block* that's fixed in the end of the beam and a removable wood *wedge* (Figure 8).

Notice that the *inside* of the filler block is cut at an angle. This creates an angled opening in the beam. By pushing the wedge (which has a matching angle) down into the opening, it pinches the lead (or blade) against the beam and holds it in place.

Oversize Blank – The filler block and the wedge are quite small. So it's best to make them from an oversize blank. After thickening this blank to match the width of the notch in the beam ($\frac{3}{8}$ "), lay out the filler block and wedge, as shown in Figure 11a. Note: The dimensions for the filler block are *rough* measurements.

Filler Block – Once the *filler block* (C) is cut to rough size, you're ready to glue it in place. The important thing here is the *size* of the opening formed by the block. To make sure the wedge fits tightly, glue in the filler block to create a $\frac{3}{8}$ "-long opening at the top (Figure 11).

Brass Pins – After trimming the block flush, I added two brass pins to

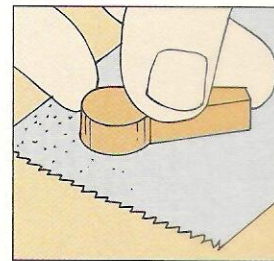
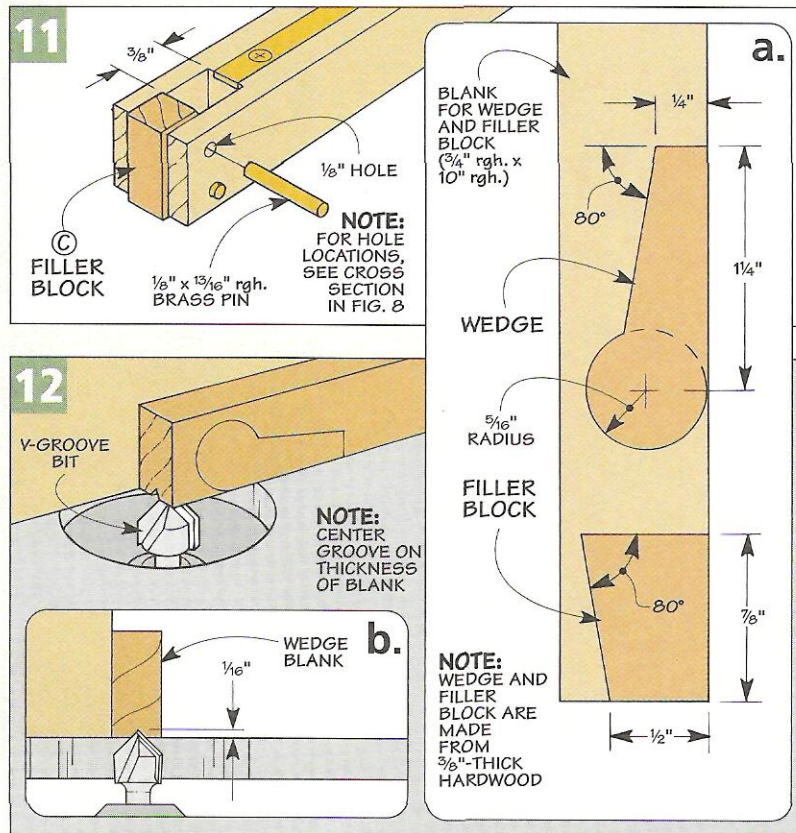

▲ To fit the wedge into the opening in the beam, sand the sides lightly on a flat surface.

help strengthen the joint. (They also add a decorative touch.) The pins are short pieces cut from a brass rod. It's best to make them slightly longer than the width of the beam. Then, after tapping the pins into holes drilled in the beam, file (or sand) them flush.

Wedge – Now you can turn your attention to the wedge. It's just a block of wood with a rounded knob on top and a V-shaped groove in the straight side to hold the lead.

For safety, it's best to rout this groove *before* cutting the wedge from the blank (Figures 12 and 12b). Then cut and sand the wedge to shape. Note: You may need to sand the sides of the wedge to get it to fit into the opening, as shown in margin.

Finishing Touches – To add some finishing touches to this special hand tool, I stained it with an aniline dye. (See box below.) Then I wiped on three coats of an oil finish. 🛠️

Sources

Water-soluble aniline dyes are available from:

- Highland Hardware 800-241-6748
- Woodcraft 800-225-1153
- Woodworker's Supply 800-645-9292

Using Aniline Dyes

Since I chose a highly-figured piece of wood for the marking gauge, I wanted that figure to "pop." The solution was to use an aniline dye. It produces a deep, rich color that doesn't obscure the grain.

Water-Soluble – The type of dye I use is a powder that dissolves in hot water. Because it's a water-based dye, it tends to "fuzz" the wood a bit. But you can keep this grain-raising to a minimum.

The trick is to dampen the wood *before* applying the dye. Then lightly sand the

"whiskers." (I use sandpaper that's one grit finer than that used on the project.)

Application – A rag or brush is all that's needed to apply the dye. To avoid lap marks, keep the surface wet and wipe off the excess before it dries.

Be aware the dye will appear chalky or dull when it dries. But applying a finish will restore the vivid color. Just be sure to use an oil-based finish since water will redissolve the dye. (Note: See margin for sources of aniline dyes.)



3-Step

Electrical Tune-Up for portable power tools

*Power tools running rough?
Or not at all? Bring them back to
life with a simple three-step tune-up.*

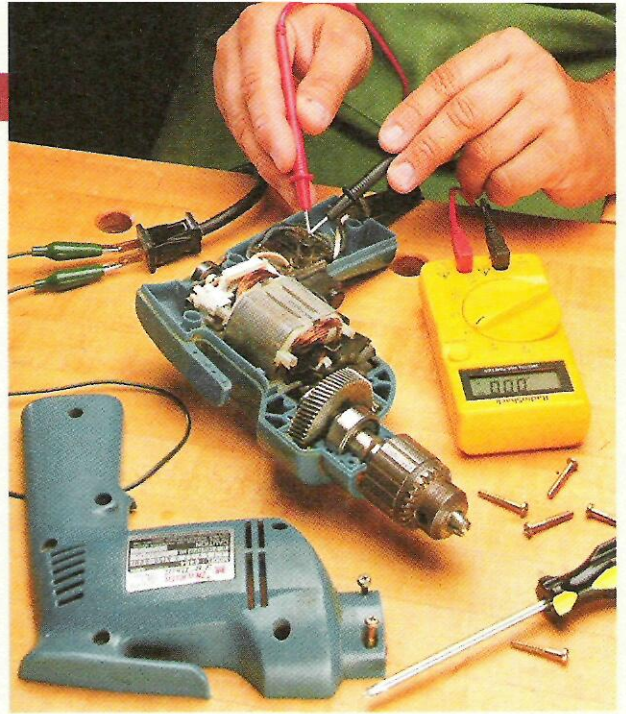

Squeeze the trigger on a drill and the chuck spins to life. Flip the switch on a router and the motor fires up in a heartbeat. It's easy to take these things for granted.

But with extended use, you may notice that a power tool isn't quite up to speed. Maybe it runs rough, or there's excessive sparking inside the case. Worse yet, you turn on the tool and nothing happens. That's usually when it gets stuck on a shelf — gathering dust instead of making it.

Of course, you could take the tool

to a repair shop, but that can be expensive. Plus it's not always necessary. Sometimes a simple fix is all it takes to get a portable power tool running as good as new.

Power Problems — If there is a problem, quite often it can be traced back to one thing — an interruption in the *electrical current* that flows into the tool, through the switch, and on to the motor. Now don't worry. You don't have to be an electrical engineer to troubleshoot problems with a power tool. But it *does* help to

know some motor basics.

Universal Motor — First of all, the type of motor used in a portable power tool is a *universal* motor. (See drawing below.) This is a lightweight motor that produces lots of torque and spins at a high rate of speed.

To accomplish this, electrical current from an outlet travels through the *plug* and *power cord* to a *switch*. When you flip the switch, the current flows through a pair of *brushes* that rub against a *commutator*. This sets up a magnetic field that spins an *armature* — and the shaft of the tool.

Three-Step Tune-Up — At least that's how it's *supposed* to work. But if there's a "break" in the loop, that's when problems develop. The trick is finding it. To do that, I use a simple, three-step tune-up which is explained in the rest of this article.

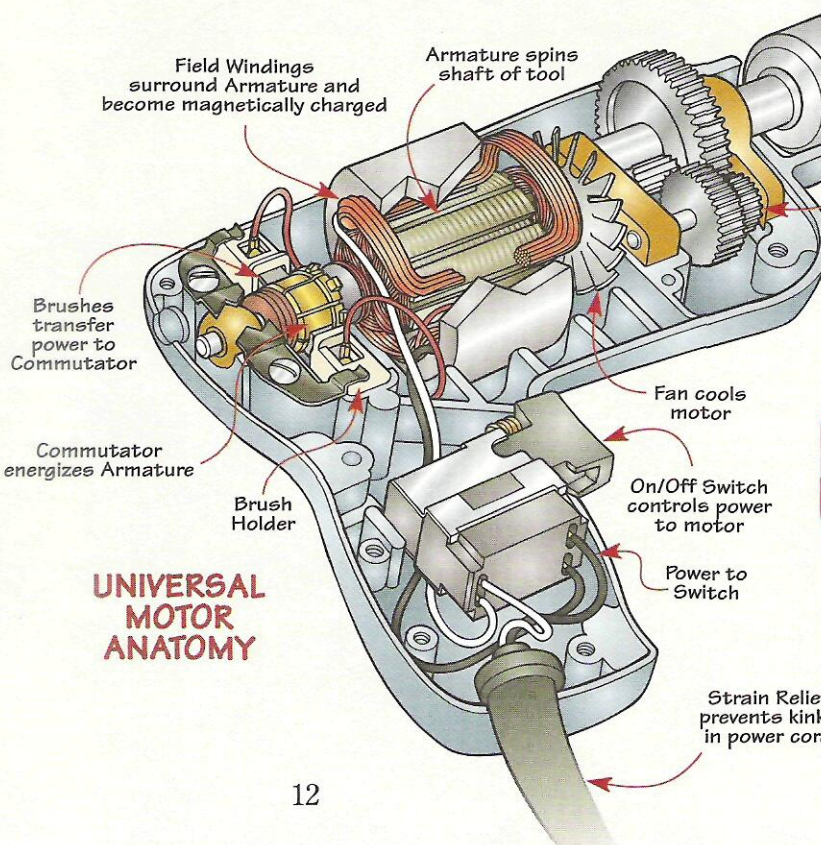

ELECTRICAL DIAGRAM

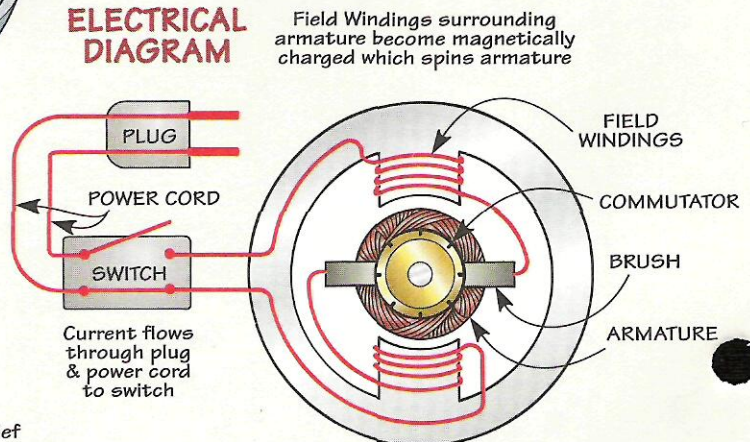

Field Windings surrounding armature become magnetically charged which spins armature

From switch, current travels through field windings and brushes to commutator

1. Visual Check-Up

If a tool runs intermittently (or not at all), check the obvious things first. A damaged plug or power cord like those shown at right can affect the performance of a tool. Plus they can cause a serious electrical shock, so it's worth taking a few minutes to replace (or repair) damaged parts.

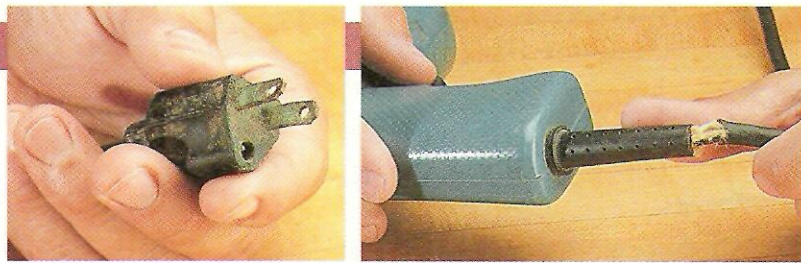

▲ **Check for Damage.** To avoid the possibility of a serious electrical shock, replace a plug if it's missing the grounding prong (shown at left) or a power cord with a break in the outer sheath (right).

REPLACING A PLUG

The first step in replacing a plug is deciding which one to buy. As a rule, I get a replacement plug that's the same type as the old plug.

Type of Plug – For a double-insulated tool, this means getting a plug with *two* prongs. (A double-insulated tool typically has a plastic housing like the drill in the photo on page 12.)

But be sure to use a *three-prong* plug if that's what the tool came with. The grounding prong on this type of plug is especially important in preventing "stray" current from energizing the case of a metal-bodied tool.

The drawing below shows a typical, three-prong plug. Notice that the terminals are color-coded, so it's easy to see which color of wire is connected

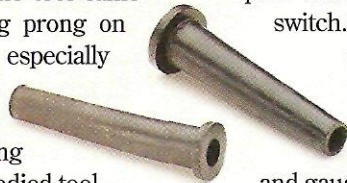

to which terminal. I also like how the cable clamp and clamp terminals keep the wires from wiggling loose.

POWER CORD POINTERS

It's no wonder that a power cord gets damaged. It gets tugged on, scuffed up, and wrapped around the tool like a tourniquet. If the damage is obvious (like a break in the outer sheath), it's time to repair or replace the cord.

If the rest of the cord looks okay, you can cut it off below the damaged part and reconnect it to the switch. If the cord is frayed or cracked, it's better to buy a new one. Just be sure to get a cord with the same number and gauge (diameter) of wires as the existing cord.

Strain Relief – Either way, you may have to get a new strain relief. This is a thick, rubber "boot" that's

molded around the cord where it enters the tool. The strain relief prevents the cord from getting a kink that could bend (or break) the wires inside. Note: You can get strain reliefs like those shown at left at many hardware stores.

Crack the Case – Before installing the power cord, you'll need to "crack" open the case to provide access to the switch. The tip in the margin at right shows a handy way to keep track of which screws go where.

Connectors – Once the case is open, you can see how the wires in the power cord are connected to the switch. As you can see in the photos below, there are several different types of connectors that might be used. It just depends on the tool.

Color Cues – What's more important is to know which color of wire gets attached to which terminal on the switch. To avoid confusion, I leave the old wires in place until I'm ready to connect the wires in the replacement cord.

Install Power Cord – To do this, start by slipping the replacement cord through the strain relief as shown below. Then remove the outer sheath of the cord and strip the insulation off each wire. After slipping the cord and strain relief into the case, connect the wires one at a time.

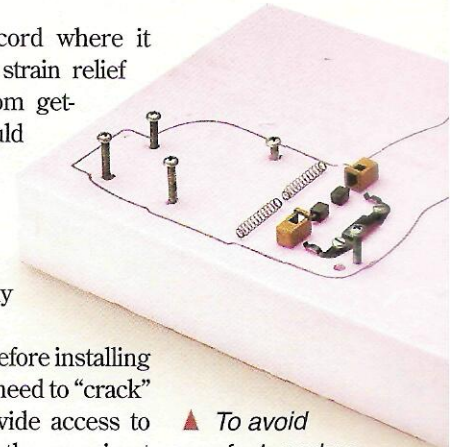

▲ To avoid confusion when reassembling a tool, draw an outline of its shape on a piece of foam insulation. Then stick screws (or other parts) in their proper location.

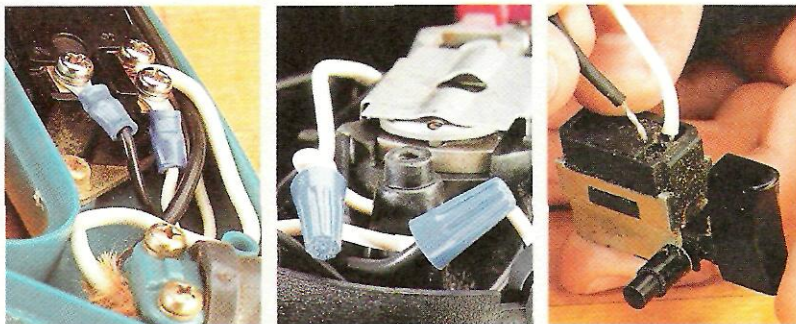

▲ **Connectors.** The wires from the power cord may be attached with crimp-on connectors (left), wire nuts (center), or a spring-loaded mechanism in the switch (right). Just be sure they're tight so they don't wiggle loose.

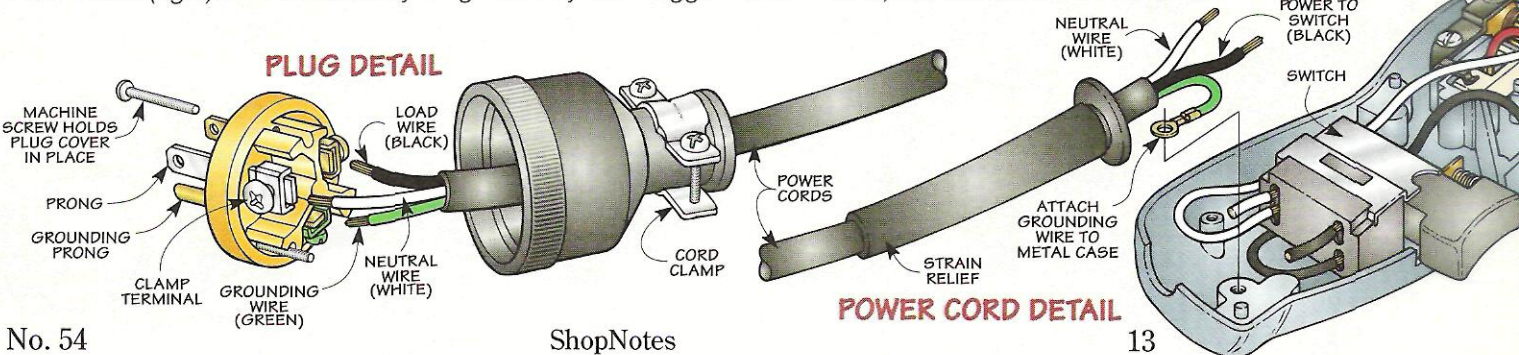

2. Test for Continuity

A visual inspection can pinpoint *some* electrical problems in a power tool. But what if everything *appears* to be okay, and the tool still won't run?

Here again, the problem is often the same — an interruption in the flow of electricity. Only this time, the interruption in the loop may be hidden.

Continuity – So how do you find out where the problem is? By testing for *continuity*. This shows whether the electrical current travels in a *continuous* path, or if there's an interruption along the way.

Multi-Meter – To do that, I use a simple testing device called a *multi-meter* like the one shown in the photo above. This is a digital meter with several settings that can be used to diagnose different problems. But to check for continuity, you'll only need to dial in a single setting — the one that measures the amount of electrical *resistance*.

Ideally, the meter should read *zero* resistance. In other words, the current flows unimpeded. To check whether the meter itself is working, touch the two probes together. This should also produce a *zero* reading.

Editor's Note: The meter shown here (Model 22-806) is available from *RadioShack* for about \$24. For a less expensive device that tests

continuity only, take a look at the photo in the margin.

Two Tests – No matter which device you use, there are *two* separate tests to make — one for the power cord and one for the switch.

CHECK POWER CORD

I usually start with the power cord. If there's a break in one of the wires *inside* the cord, it's not always visible on the outside. The only way to find out is to hook up the multi-meter.

The idea is to check whether current from the meter (there's a small battery inside) flows from one end of the cord to the other. This requires checking continuity between the plug and the points where the wires connect to the switch.

Alligator Clips – An easy way to do this is to start by using a pair of alligator clips to “jump” across the two prongs of the plug, as shown in Step 1 below. (Alligator clips like the ones shown above are available at most electronic supply stores.)

After hooking the clips to the prongs, the next step is to locate the ends of the wires that connect to the switch. That's easy if the terminals

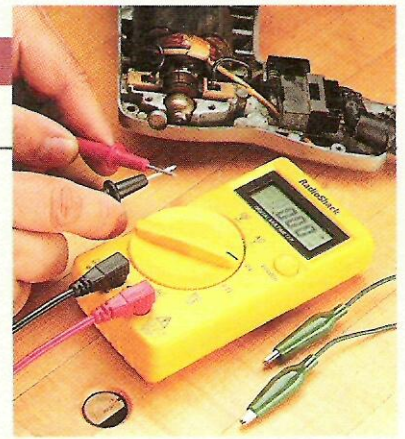

Meter Check – Touching the two probes of a multi-meter together should produce a zero reading — just like when checking for continuity.

on the switch are exposed as in Step 1. But if the wires go straight into the switch, you'll need to pull them out. Most likely, the wires are held in place with a spring-loaded mechanism. To release each wire, stick a needle into the slot next to it. Then push down and pull the wire loose.

Once you've located (or exposed) the ends of the wire, touch the probes to them to check for continuity in the power cord. Remember, the meter should read zero if the cord is okay. If not, replace it as shown on page 13.

TEST THE SWITCH

The next step is to see if the switch works. Again, it may look fine. But after switching it on and off hundreds of times, a switch may wear out.

To test the switch, the procedure is basically the same. This time, you're checking whether the current from the meter flows through the switch when it's in the “on” position.

A look at Step 2 shows an easy way to do this. Start by attaching alligator clips to the points where the wires from the power cord connect to the switch. (These are the same two points you touched the probes to in Step 1.)

Now locate the two wires that *leave* the switch and go to the motor. Touch the probes to these two points, and press the switch to the “on” position. Again, a *zero* reading indicates the switch is good. If it's broken, it's best to order a new switch from the manufacturer.

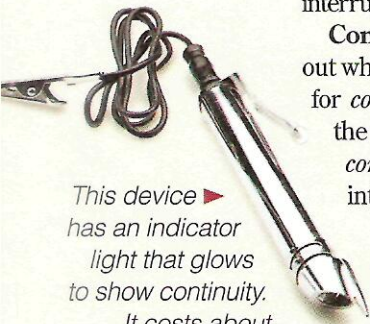

This device ► has an indicator light that glows to show continuity. It costs about four dollars at an electrical supply company.

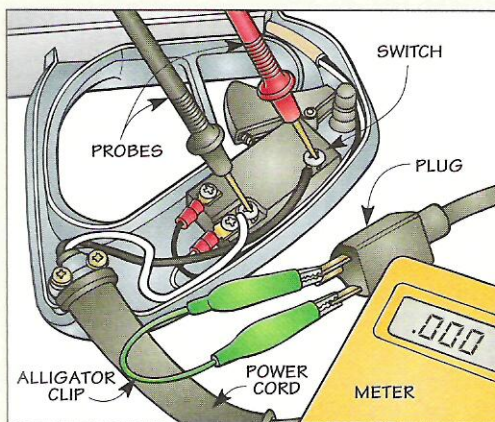

1 To check continuity in the cord, attach clips to the prongs of the plug. Then touch the probes to the terminals where the wires from the power cord connect to the switch.

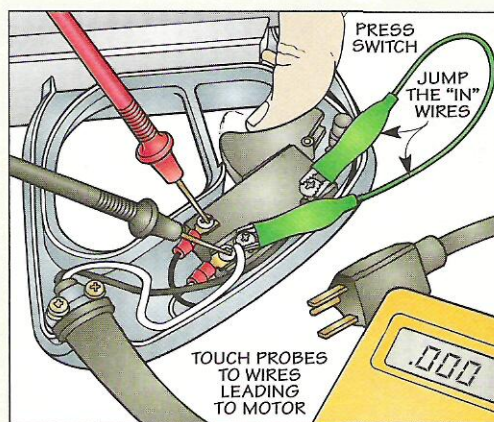

2 Now test the switch. To do this, attach the clips to the terminals where the power cord enters the switch. Then touch the probes to the wires leading to the motor and press the switch.

3. Inspect Brushes

Okay, so what if there's continuity in the power cord and the switch, but the tool *still* runs rough? Or not at all? It's time to inspect the brushes.

Carbon Blocks – There are two brushes. Actually, the word “brushes” is a bit deceiving. They're solid blocks of a carbon-graphite material that rub against the commutator.

To keep the brushes in contact with the commutator, they're attached to springs. These spring-loaded assemblies fit into a metal brush holder, one on each side of the commutator.

Brush Power – A wire leading to one of the brushes (or holder) supplies power from the switch. When you flip the switch, the brush feeds power to the commutator. With use,

brushes wear down and don't make good contact with the commutator. This causes a loss of power or excessive sparks.

Remove Brushes To inspect brushes for wear, you'll need to remove them. Depending on the tool, access to the brushes is either on the *outside* or *inside* of the case. (See photos above.) Note: To ensure even wear, reinstall the brushes on the same side of the tool they came out of.

After removing the brushes, you may find they're chipped or burned. (See margin.) But a more likely problem is they're too short. The brushes simply

wear down past their useful life.

What's the minimum length of a brush before it needs to be replaced? Sometimes there's an indicator marked on the brush. If not, a good rule of thumb is to replace the brushes when they're *shorter* than they are *wide*. Note: Replacement brushes are available from the manufacturer and some hardware stores.

Final Check – With new brushes installed, the tool should run like a top. If it doesn't, there may be a more serious problem with the copper windings in the motor. If the tool has been overheated, the insulation on the windings may have melted. This can cause the windings to “short out.”

To check, use an alligator clip to “jump” across the two wires leading from the switch to the motor. Then remove the brushes and place the probes against the metal holders. If the meter doesn't read zero, your best bet is to replace the tool or take it to a repair shop. ⚠

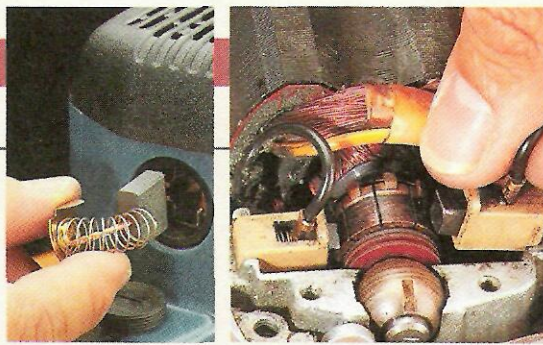

Brush Access – A removable cap makes it easy to take out some brushes (left). The only way to remove other brushes is to open the case (right).

Chipped



Burned

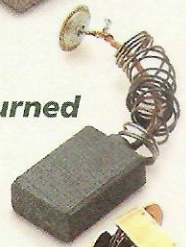

Worn

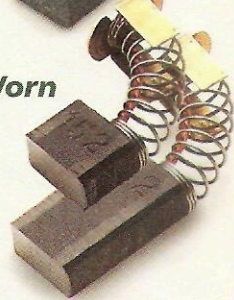

▲ Occasionally, you'll find a chipped or burned brush that needs to be replaced. More often, the brush is worn to the point that it's too short.

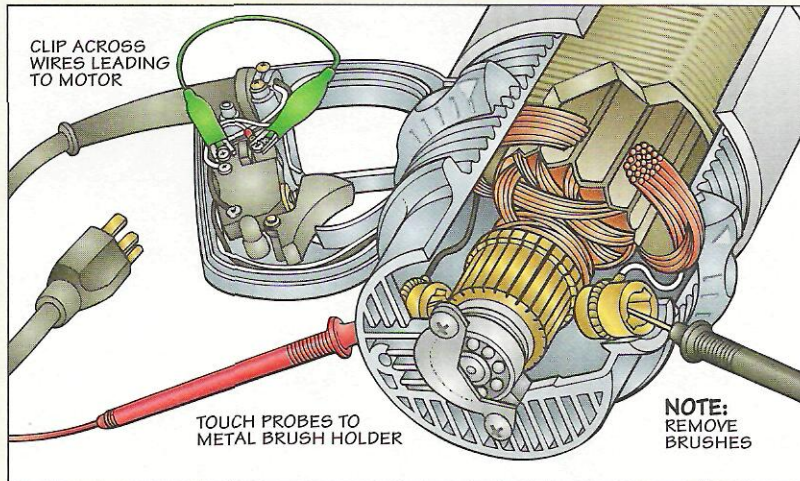

An Ounce of Prevention

When it comes to taking care of the electrical components of a tool, prevention is the best cure.

Blow Out Dust – For example, dust can prevent a tool from breathing. This causes it to overheat which can damage the motor. So I remove as much dust as possible by turning on the tool and blowing air through the intake slots (Photo A).

Cord Wrap – Even a simple thing like how the power cord is wrapped around a tool can keep problems from cropping up (Photo B).

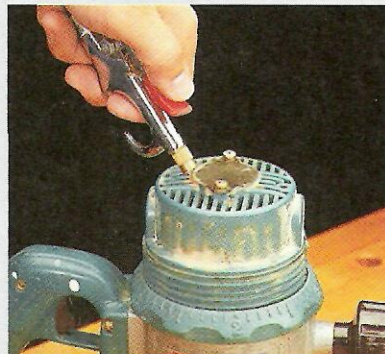

A. Remove Dust – With the tool running, blow air through the intake slots to remove packed-in dust.



B. Cord Wrap. To reduce the strain on a power cord, make a large loop before wrapping it around the tool.

A custom cart for “tooling” around the shop.

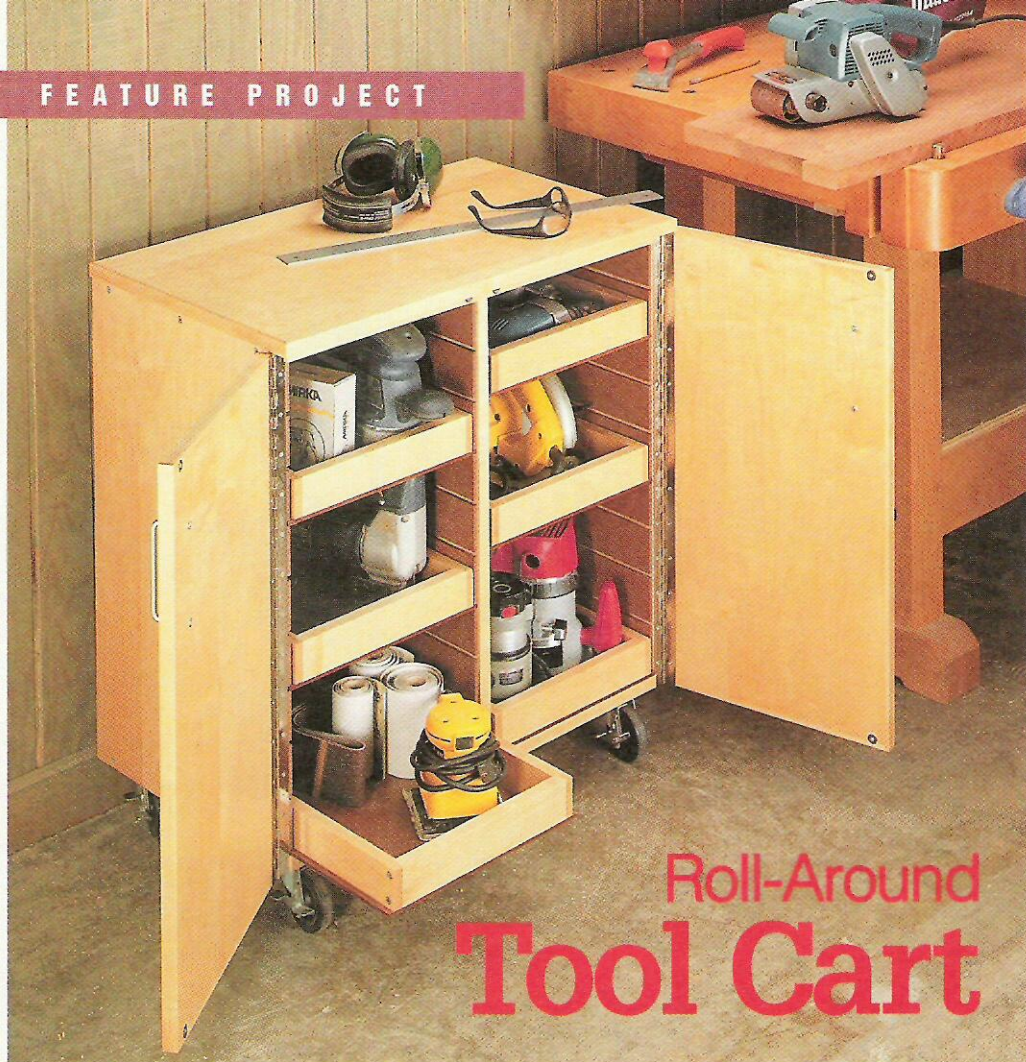

Roll-Around Tool Cart

One big box and a bunch of small boxes — that’s all there is to this roll-around cart. Yet as simple as it is, it provides a great way to store portable power tools.

Pull-Out Trays — First of all, it has a number of shallow, pull-out trays to help organize power tools and accessories (and keep them in easy reach). Just slide out a tray to grab a tool, carry the entire tray with you, or roll the cart up next to the bench or out on the driveway.

Adjustable Height — So what happens if you get a new tool that won’t fit because the trays are too high or too low? It’s no big deal. Simply adjust the height of the trays as shown in photo A below.

Compact Storage — Regardless of the arrangement of the trays, the cart holds *lots* of tools. Even so, it’s quite compact (Photo B). Plus, it’s sturdy enough to use as a benchtop tool stand (Photo C).

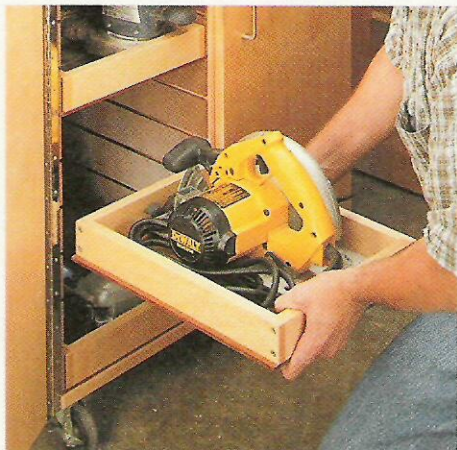

A. Adjustable Height. If your storage needs change, just slide a tray out and then slip it back in at a different height.

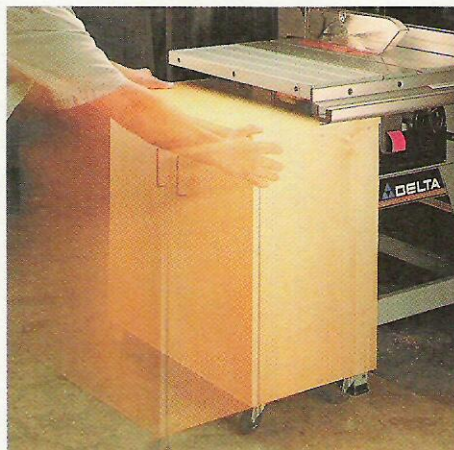

B. Compact Cart. To take advantage of unused space, you can park this compact cart under the wing of a table saw.

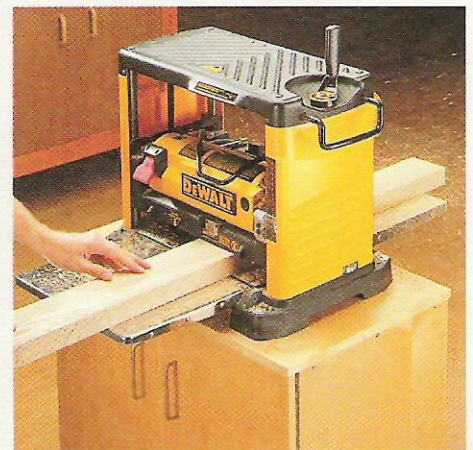

C. Tool Stand. With a sturdy top and a set of locking casters, this cart can also serve as a stable platform for a benchtop tool.

To get a **free** cutting diagram for this project:

Visit us on the Web at **ShopNotes.com**

Or send a stamped, self-addressed envelope to:

ShopNotes Cutting Diagrams
Power Tool Cart
2200 Grand Avenue
Des Moines, Iowa 50312

EXPLODED VIEW
OVERALL DIMENSIONS:
28½"W x 17"D x 30¾"H

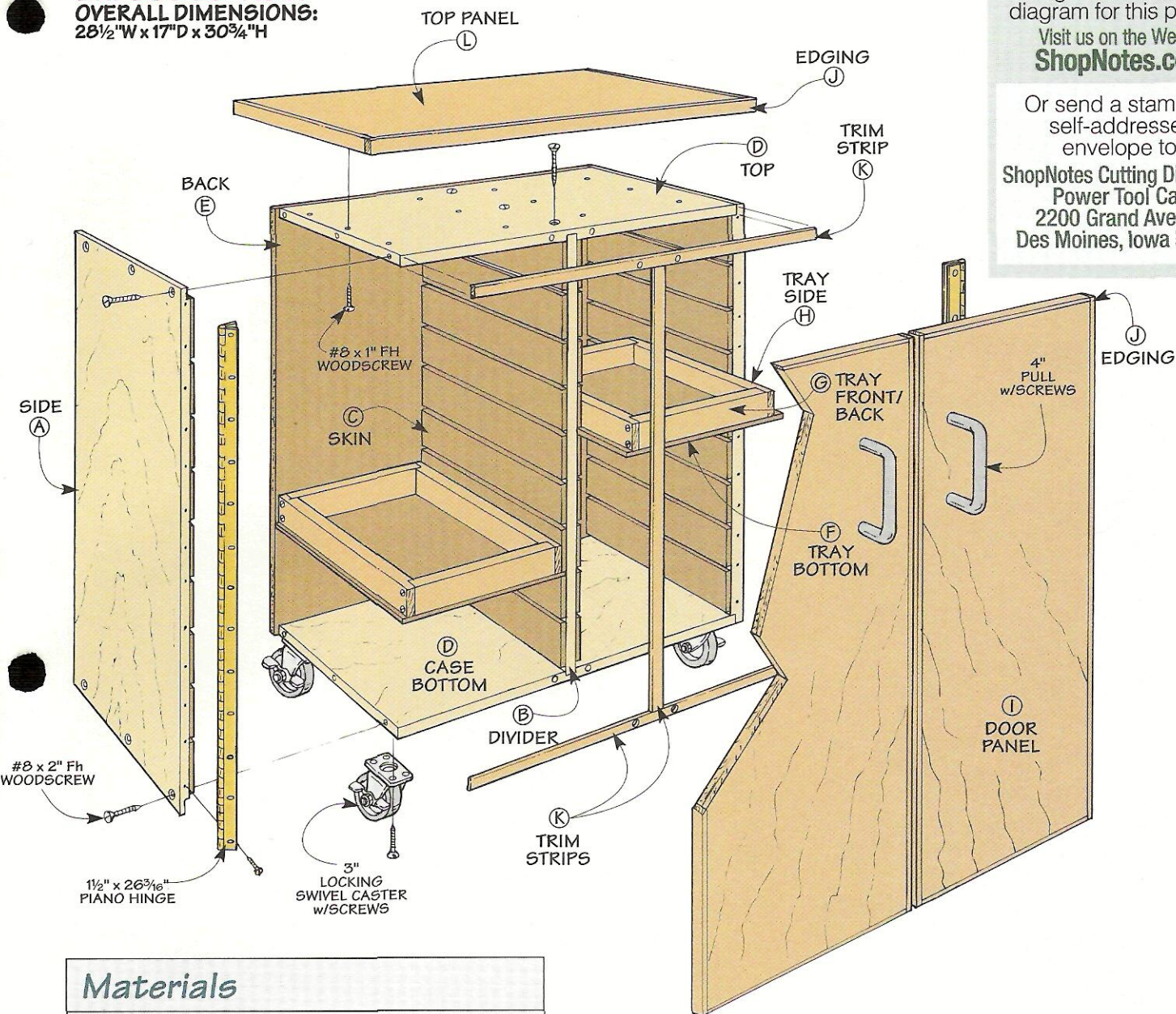

Materials

Case

- A Sides (2) 15¹⁵/₁₆ x 26¹/₄ - ³/₄ Plywood
- B Divider (1) 15⁹/₁₆ x 25¹/₄ - ³/₄ Plywood
- C Skins (4) 16 rgh. x 26¹/₂ rgh. - ¹/₄ Hdbd.
- D Top/Bottom (2) 15⁹/₁₆ x 27 - ³/₄ Plywood
- E Back (1) 26¹/₄ x 27¹/₂ - ¹/₄ Hardboard

Tool Trays

- F Bottom (6) 12¹³/₁₆ x 15⁹/₁₆ - ¹/₄ Hardboard
- G Front/Back (12) ³/₄ x 2 - 11¹/₄
- H Sides (12) ³/₄ x 2 - 15⁹/₁₆

Doors/Worksurface

- I Door Panels (2) 13¹/₂ x 25¹¹/₁₆ - ³/₄ Plywood
- J Edging ¹/₄ x ³/₄ (20 Linear Ft.)
- K Trim Strip ³/₁₆ x ³/₄ (7 Linear Ft.)
- L Top Panel (1) 16³/₄ x 28 - ³/₄ Plywood

Hardware

- (4) 3" Locking Swivel Casters w/Screws
- (2) 4" Steel Pulls w/Screws
- (4) Magnetic Catches
- (4) Strike Plates w/#4 x ³/₈" Fh Woodscrews
- (66) #8 x 2" Fh Woodscrews
- (60) #8 x 1" Fh Woodscrews
- (10) #8 x ¹/₄" Fh Woodscrews
- (16) #14 x ⁵/₈" Ph Sheet Metal Screws
- (29) #6 x ³/₄" Fh Woodscrews
- (2) 1½" x 26³/₁₆" Piano Hinges
- (52) #5 x ⁵/₈" Fh Woodscrews

Case

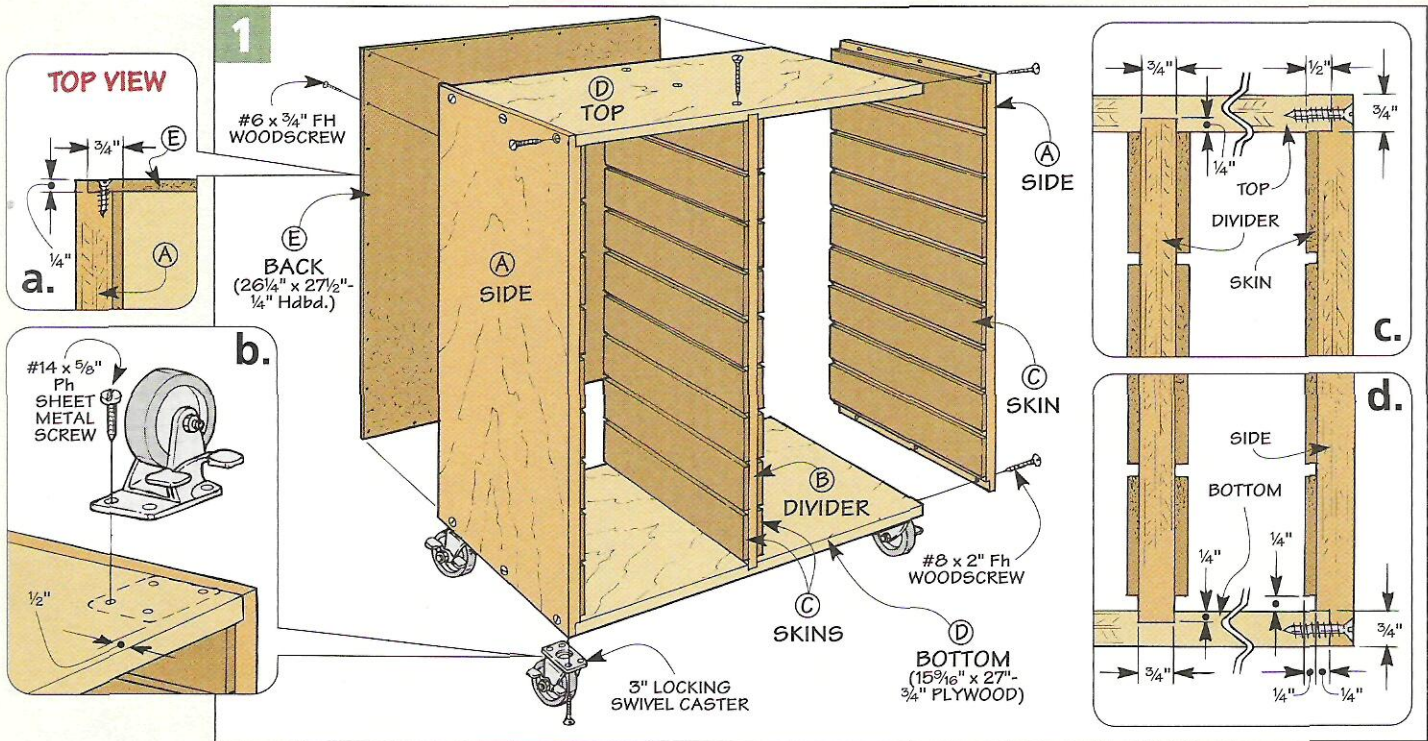

I began work on the tool cart by making the case. It's an open-fronted box that's divided into two large compartments that hold the tool trays. (Refer to Figure 1.)

Sides & Divider – The case starts out simply enough — two *sides* (A) and a *divider* (B) made from 3/4" plywood. As you can see in Figure 2,

these pieces are identical in length (26 1/4"). But to provide clearance for a hardboard back, the divider is 1/4" narrower than the sides. Note: The divider will be trimmed shorter before the case is assembled.

Skins – After cutting these pieces to size, the next step is to add four *skins* (C). These are hardboard panels

that cover *both* sides of the divider and the *inside face* only of the sides (Figure 2). The purpose of these panels is simple. They “beef up” the case and provide the extra thickness needed to accommodate a set of dados that hold the tool trays. Plus, the hardboard creates a smooth, durable surface for the trays to ride on.

The goal is to tie up with panels that are flush with the sides and the divider all the way around. Of course, the panels might slip and slide around when clamping pressure is applied. So it's best to cut the panels oversize and then trim them flush later.

Glue On Panels – When it comes to gluing on the panels, there are two challenges. How do you apply pressure near the middle of the panel? And how do you distribute the pressure evenly? The trick is to turn a few scrap pieces of wood into a large “press.” (Refer to the box on page 19.)

Trim Flush – Once the glue dries, you can trim the panels flush with the edges of the plywood. A hand-held router and flush trim bit make quick work of this (Figure 2a).

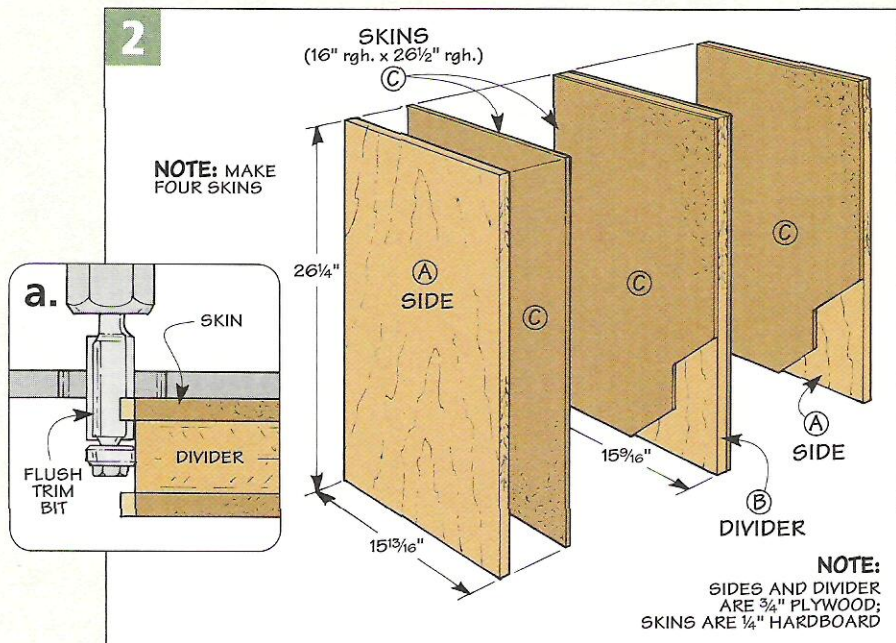

Tool Trays

With the case complete, you can turn your attention to the sliding trays. I built six trays to hold my tools and then customized one of them as shown in the margin.

Each tray consists of a wood frame attached to a piece of hardboard (Figure 4). Notice in Figure 4a that the hardboard extends *past* the sides of the frame. This creates a lip that slides in and out of the dadoes in the sides and divider.

Bottom – I began by making the hardboard bottom (F) of each tray. To slide smoothly without binding, I cut it to width so it's $\frac{1}{16}$ " less than the distance between the dadoes. As for length, it

matches the depth of the case.

Frame – The next step is to add a hardwood frame to each tray bottom. The frame consists of a front/back (G) piece and two sides (H) assembled with rabbet joints. After cutting the frame pieces to length, it's just a

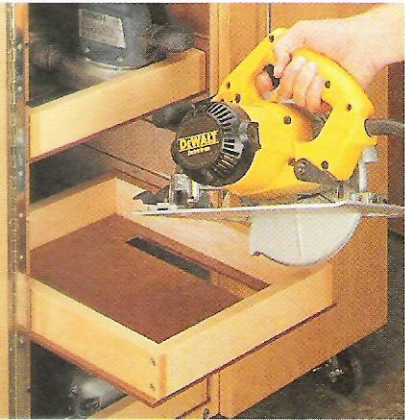
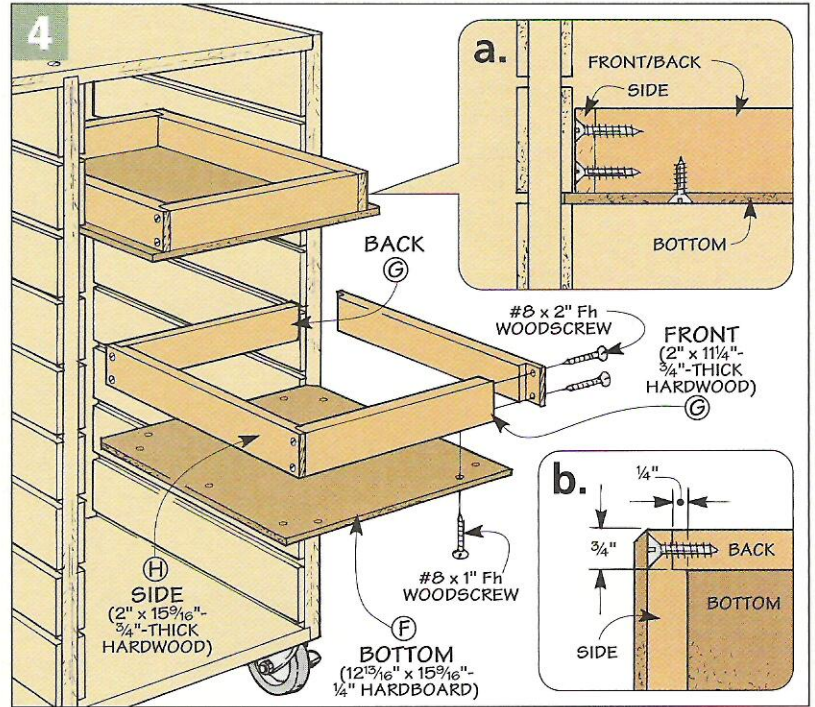

▲ To allow my circular saw to sit flat, I cut a long slot in the bottom of the tray that's wide enough to fit the blade guard.

matter of cutting the rabbets in both ends of the sides (Figure 4b). Then glue and screw the frame together.

Attach Frames – Now you're ready to attach the frames. Each frame is centered from side to side

on the tray bottom, and it's flush in front. After screwing the frame in place, I "knocked off" the back corners of the tray bottom so it slips easily into the case (Figure 4b).

DOORS

After completing the trays, I added a couple of doors to keep as much dust out of the cart as possible. The doors are $\frac{3}{4}$ " plywood panels surrounded with solid wood edging (Figure 5).

Size – It's easy to make the doors. But it takes some pencil work to figure out their size. For starters, they're flush with the sides and bottom of the case. But they're $\frac{1}{16}$ " shorter than the height of the cart. When a work surface is added later, this creates a $\frac{1}{16}$ " gap that allows the doors to swing open (Figure 8b). Finally, you'll want to allow for at least a $\frac{1}{16}$ " gap between the doors (Figure 5a).

Now it's just a matter of cutting the two plywood door panels (I) to final size. Then rip enough hardwood edging (J) to fit around the doors and glue the strips in place.

Hinging the Doors – With the doors complete, the next step is to hinge them to the case. As you can

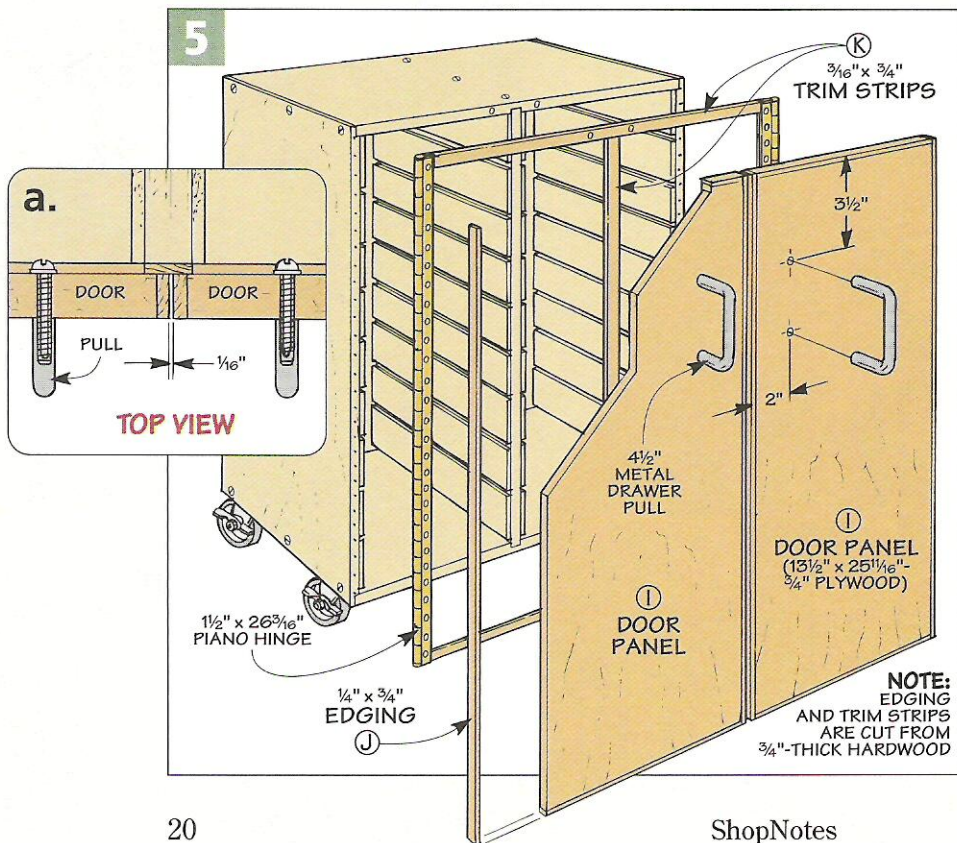

see in Figures 5 and 6, they're held in place with piano hinges. Notice in Figure 6a that the knuckle of each hinge sticks out past the *outside* of the case. This provides the clearance that's needed *inside* to slide the trays in without catching on the hinge.

After screwing the hinges in place, try out the doors to make sure they swing freely. One thing you'll notice is the doors won't shut tightly against the case without "springing" the hinges. That's because the thickness of the hinges creates a gap between the doors and the cart.

Trim Strips – The solution is to add three *trim strips* (K), as shown in Figure 5. These are just strips of hardwood that match the thickness of the hinge ($\frac{3}{16}$ "). The top and bottom strips are cut to length to fit between the hinges. And the center (vertical) strip covers the front edge of the divider.

When gluing on the top and bottom trim strips, it's easy to clamp across the cart. But that won't work for the strip on the divider. Since the back of the cart is already in place, you can't put a clamp on the back edge of the divider. So to apply pressure, try using the tip shown in the margin.

Magnetic Catches – After gluing on the trim strips, I added a set of magnetic catches and strike plates to keep the doors closed. They fit in counterbores drilled in the top and bottom edges of the case and the

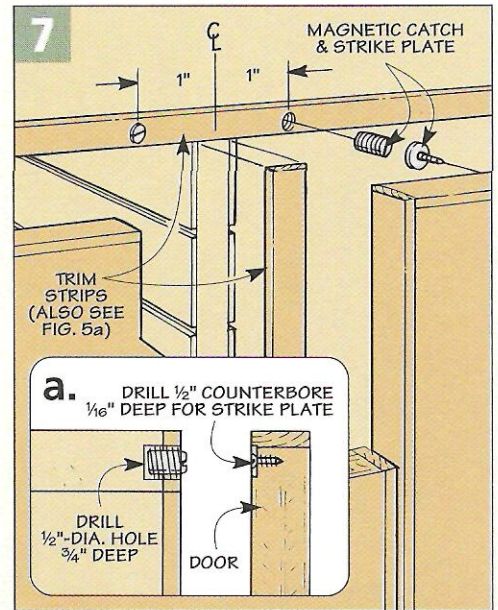
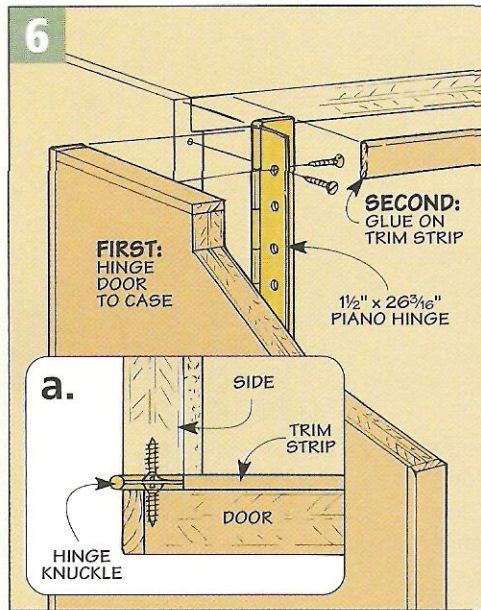

doors (Figures 7 and 7a). A small amount of epoxy holds the catches in place. The strike plates are just screwed to the doors. Then to complete the doors, I installed two metal pulls (Figures 5 and 5a.)

WORKSURFACE

Like many horizontal surfaces in my shop, I figured I'd use the top of this cart as a work area (or tool stand). But I didn't want things "catching" on the doors. So I added a large worksurface to the top of the cart.

Like the doors, the worksurface is made up of a $\frac{3}{4}$ " plywood panel with hardwood edging (Figure 8). But this time, the edging is applied only

to the *front* and *ends* of the panel.

Size – Keep that in mind when determining the overall size of the worksurface. It's sized to fit flush with the back of the cart and to overhang the sides and front by $\frac{1}{4}$ " (Figures 8a and 8b).

Once you know the size, it's just a matter of cutting the plywood *top panel* (L) and then gluing on the *edging* (J). Finally, fasten the worksurface to the top of the cart by driving in screws from inside.

Conclusion – At this point, the cart is completed. But after rounding up your tools and loading up all the trays, there's bound to be lots more "toolin' around" in store. 🛠️

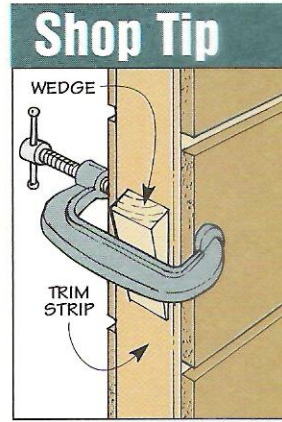
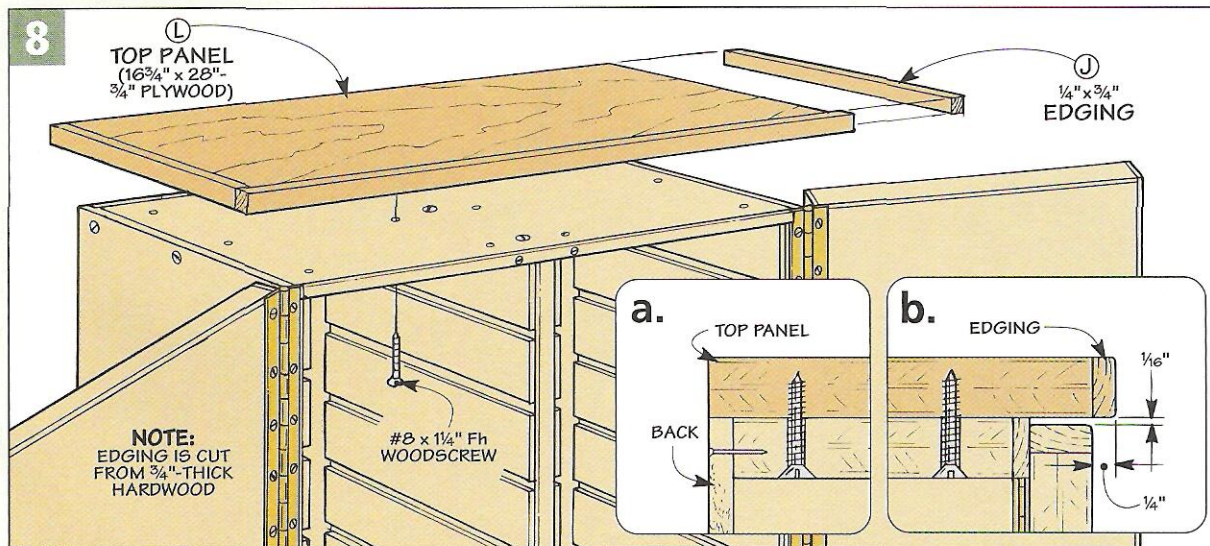

▲ When gluing the trim strip to the divider, it's easy to apply pressure. Just tuck a wood wedge between a C-clamp and the trim strip.

Circular Saw Jigs

Don't sell your circular saw short. Get precision results with five simple jigs.

One of the first portable power tools often purchased is a circular saw. It's also one of the most versatile. Whether you're cutting a 2x4, breaking down a sheet of plywood, or building a project around the house, a circular saw definitely gets a workout.

But in spite of that, a circular saw often gets shortchanged. Typically, it has a reputation as a tool used only for rough carpentry work. That's too

bad really. Especially since all it takes to convert a circular saw into a precision tool is to make a few jigs.

Five Jigs – Now I'm not talking about complicated, time-consuming jigs. Take the five jigs shown in the next few pages for instance. Each of these jigs can be knocked out in a half hour (or less). As for material, a few scrap pieces is all it takes. But most important, each jig makes it easy to produce a straight, accurate cut.

Blade Selection – While these jigs definitely improve accuracy, it's the saw blade that determines the quality of cut. To end up with a smooth, clean cut, the key is to select a blade that's best suited to the job at hand, as shown in the blue-colored box below.

The Basics – With a good blade, you'll be on your way to making a smooth cut. But to ensure a safe, controlled cut, it's worth taking a minute to review the basics shown below.

Which Blade?

Combination ▶

For general purpose work like ripping and cross-cutting lumber or man-made materials, select a carbide-tipped combination saw blade.

Ripping ▶

With fewer teeth that "lean" forward, this rip blade makes fast cuts with the grain. An anti-stick coating prevents the blade from gumming up.

Crosscutting ▶

Lots of small, knife-like teeth produce a glass-smooth surface when cutting across the grain with this all-steel (no carbide) saw blade.

Plywood ▶

To make crisp, clean cuts in plywood, this steel blade has two hundred, razor sharp teeth. A rim that's thinner than the "hub" prevents binding.

Specialty ▶

Carbide-tipped teeth, an anti-stick coating, and S-shaped heat vents make this special-purpose blade ideal for cutting pressure-treated lumber.



6 Tips for Troublefree Cuts

- 1 Set Up Supports.** Support the board so the waste will fall free. (See drawing below.) Then clamp the work with the "good" side face down.
- 2 Adjust Depth of Cut.** To clear dust from the kerf, adjust the depth of cut so the gullets in the blade extend past the bottom of the board.
- 3 Think Safety.** Be sure to wear eye and ear protection. Also, loop the power cord over your shoulder to avoid accidentally cutting it.
- 4 Get a Grip.** To make a controlled cut, grasp the saw with both hands and set the wide part of the metal base on the workpiece — not the cutoff.
- 5 Stand to the Side.** Always stand to the side of the saw (not behind it). This way, you'll be safely out of the way if the blade binds or kicks back.
- 6 Maintain Speed.** Move your whole body forward to maintain a steady cutting speed. Don't force the saw blade or overextend your reach.

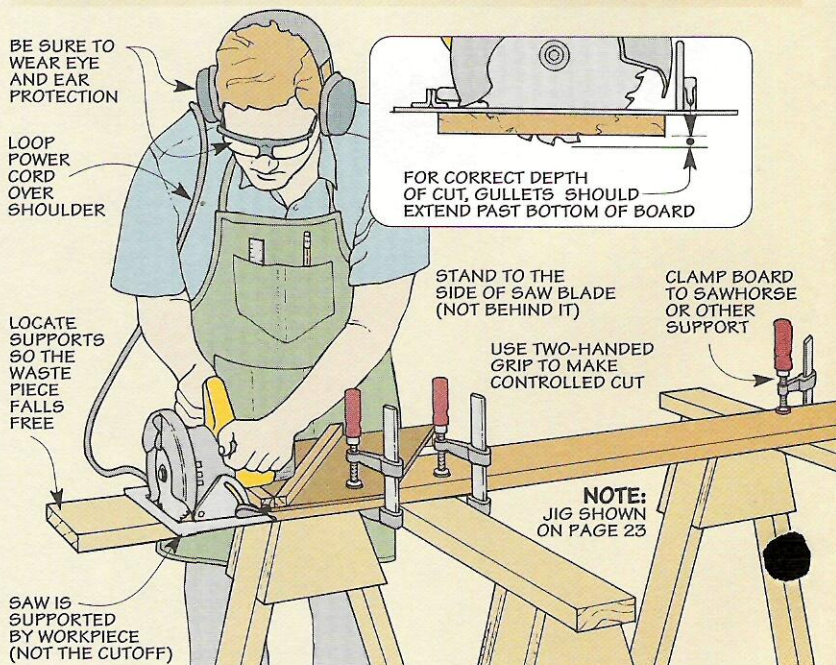

1. Crosscut Guide

One of the jigs I use frequently is the simple *crosscut guide* shown in the two photos below. It provides a quick, accurate way to make a 45° miter or 90° crosscut — without any guesswork. Just mark the board, position the jig on the line, and make the cut.

Base – The base of this crosscut guide is made from a 12"-wide piece of 1/4" hardboard. As for length, it's best to start with an extra-long piece. (I made mine 30" long.) Note: Later, the waste is trimmed off each end to form two *reference edges* that are used to align the jig to a layout line on the workpiece.

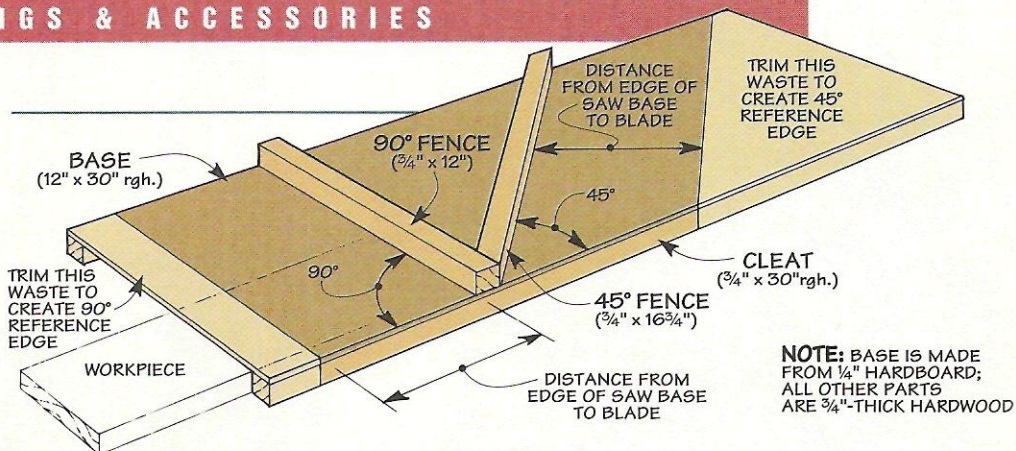

Fences – The next step is to add two hardwood *fences* that are used to guide the saw, one for 90° crosscuts and the other for 45° miters. After trimming the ends of the 45° fence at an angle, carefully position both

fences and then glue them in place.

Cleats – Finally, to square the jig to the edge of the board, glue two hardwood *cleats* to the bottom of the base. Then trim the waste off each end to create the reference edges.

NOTE: BASE IS MADE FROM 1/4" HARDBOARD; ALL OTHER PARTS ARE 3/4"-THICK HARDWOOD



▲ **45° Miters.** To make precision 45° miters, align the angled end of the crosscut guide with the layout mark. Then run the base of the saw against the fence as you make a cut.



▲ **90° Crosscuts.** Simply turn the guide around and align the opposite end to make a 90° crosscut. To square the jig, make sure the cleat is tight against the workpiece.

2. Cutoff Saddle

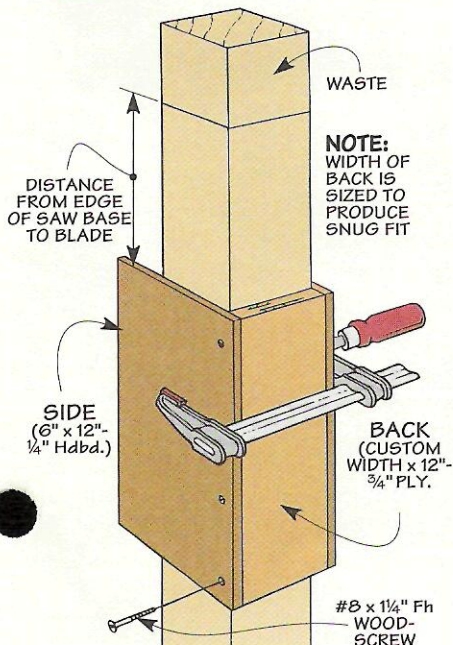

Working with thick lumber (like a 4x4 post) presents a challenge. Even with the saw set for the maximum depth of cut, the blade still won't cut all the way through.

The way to get around this is to make *two* cuts, working from opposite sides of the post. The only problem is the kerfs don't always line up. So you end up with a small ridge of material on the end of the post and a cut that's not square.

Saddle – The solution is to clamp a U-shaped "saddle" to the post, as shown at right. This saddle serves as a guide for the base of the saw which makes it easy to produce a smooth, square cut. Just cut one side of the post, then flip it to the opposite side to make the second pass.

To make the saddle, simply screw a pair of hardboard *sides* to a plywood *back*. (See drawing.) Just be sure to size the back so the saddle fits snug around the workpiece.

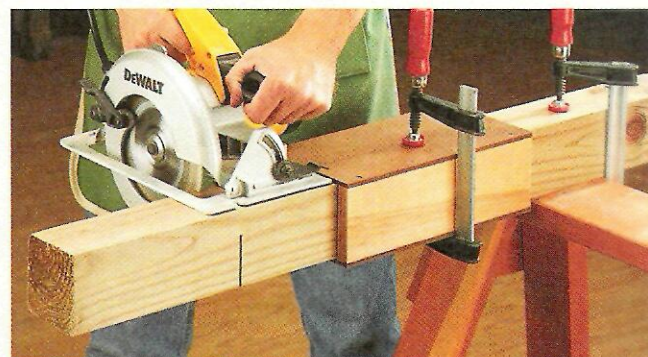

▲ **Cutoff Saddle.** To ensure smooth, square cuts when working with thick lumber, this cutoff saddle guides the saw when making cuts from two opposite sides of the post.

3. Edge Guide

I know guys who can use a circular saw freehand to make a straight cut from one end of a board to the other. But to be honest, I need a guide that rides against the edge of a board to make a *straight* rip cut.

Although I've tried a number of metal edge guides, I've been a bit disappointed in them. Often the guide flexes, or it's too short. As a result, the saw blade tends to veer off or bind.

To solve these problems, I made the edge guide shown in the photo below. It makes it easy to rip a board up to 10" wide. This edge guide consists of two main parts: a *base* that serves as a mounting platform for the saw and an adjustable *fence*.

Base – If you look at the drawing at right, you can see that the base of the edge guide is a piece of 1/2" plywood with two grooves in the bottom. Later, these grooves accept keys that will help align the fence.

To make the fence adjustable, there's a long slot in the base. You'll also need to cut an opening for the saw blade and guard to fit through. (I cut it to match the opening in the metal base of the saw.)

Cleats – The saw base is held in place with a system of cleats. A couple of two-part cleats hold the front and back of the saw base. And two hardboard strips form cleats on the sides.

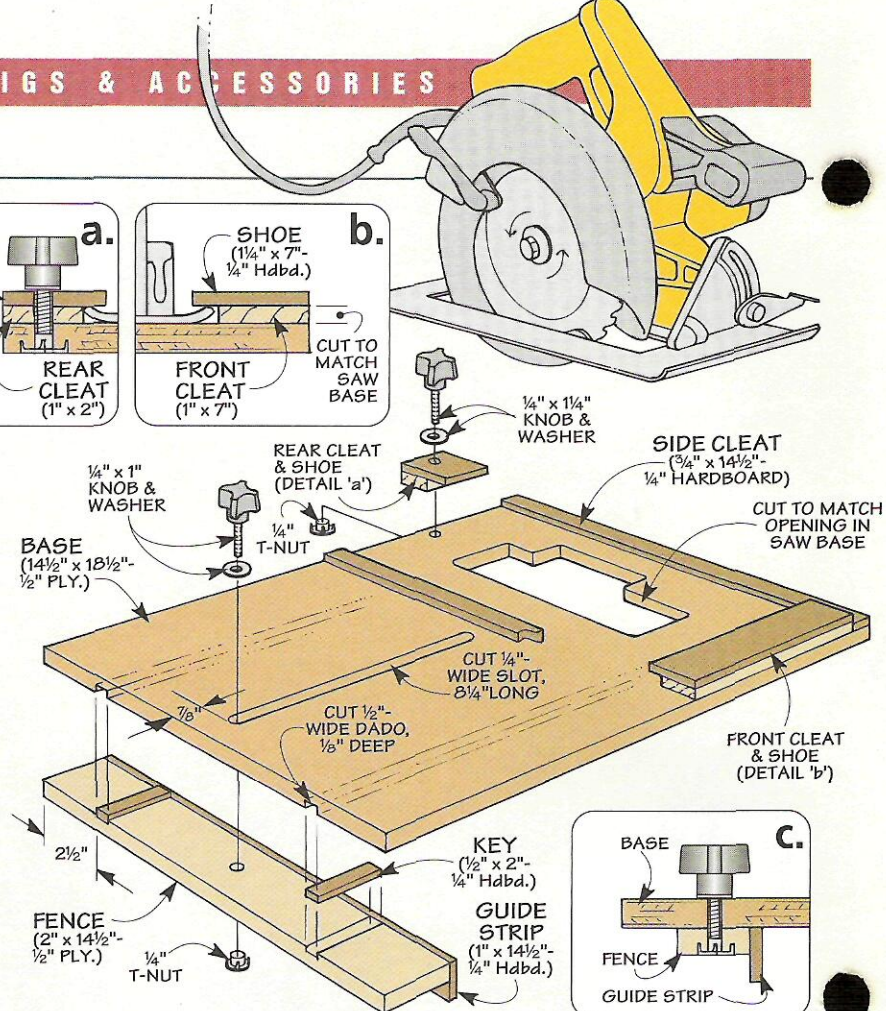

Just a note about the *front* and *rear cleats*. The lower part of each cleat is a scrap piece of wood that's thickened to match the height of the saw base (details 'a' and 'b'). This way, a wider strip of hardboard glued on top forms an overhanging lip for the metal base of the saw to slide under.

Although the front and side cleats are glued to the base of the edge guide, the rear cleat is removable.

It's held in place with a threaded knob and T-nut. Just take this cleat off to slide the saw under the front cleat. To secure the saw, reinstall the rear cleat and tighten the knob.

Fence – After completing the base of the edge guide, you can add the fence. The nice thing about this fence is it's long and rigid — just what you need to plow a perfectly straight cut down the length of a board.

The *fence* starts out as a strip of 1/2" plywood. A couple of dadoes in the top of the fence hold a pair of hardboard *keys*. They fit into the grooves in the base which keeps the fence parallel to the saw blade as you move it back and forth.

After gluing in the keys, I glued a hardboard *guide strip* to the edge of the fence. It provides a wider (taller) surface to ride against the workpiece than the fence by itself.

Attach Fence – At this point, all that's left is to attach the fence. It's held in place by tightening a threaded knob that passes through the adjustment slot into a T-nut.

Edge Guide ▶ Plow perfectly straight rip cuts with this adjustable edge guide. Notice the block underneath that prevents the blade from cutting into the sawhorse.

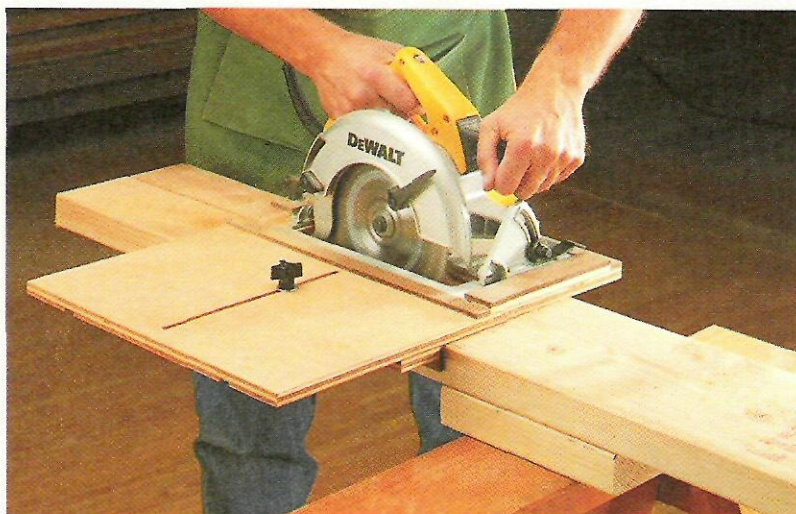

4. Story Stick

Need to cut a number of boards to identical length? A *story stick* like the one shown at right provides a fast, accurate way to cut multiple pieces to length — without having to measure and mark.

A story stick is a scrap piece of lumber (I use a 2x4) that matches the desired length of the pieces you plan to cut. As you can see in the drawing below, there's a block screwed to one end of the story stick. In use, this block hooks over the workpiece, and the saw rides against the end of the story stick as you make a cut.

The important thing is the *length*

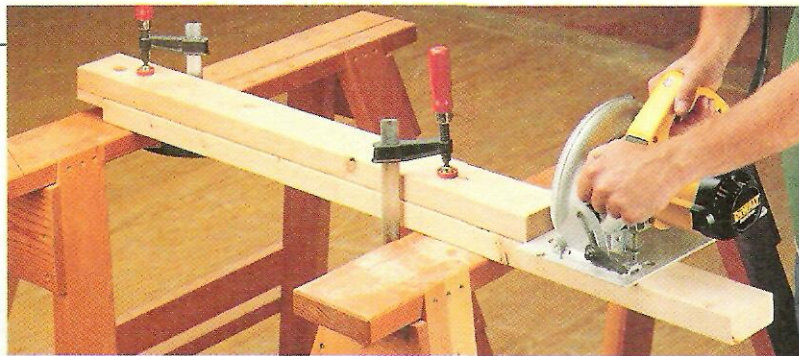

◀ **Story Stick.**
To cut a number of boards to the same length, hook a story stick over the end of each piece. Then run the saw against the end of the story stick to cut a board that's identical in length.

of this block. The idea is to cut it to match the *offset* of the saw blade (the distance from the blade to the edge of the metal saw base). This way, every cut produces a board that's identical in length to the story stick.

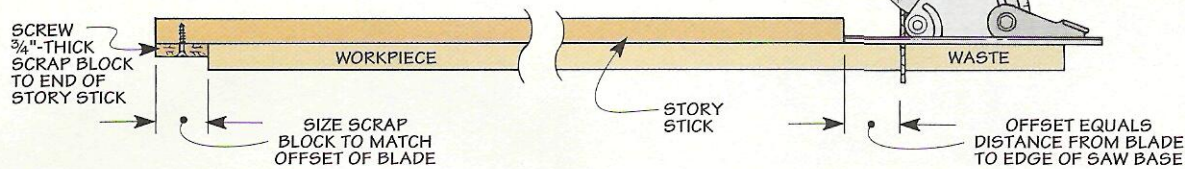

5. Panel-Cutter

Here's a handy jig to use when cutting a large panel (like a sheet of plywood) down to size. When used with a special plywood-cutting blade, this panel-cutter produces a smooth, finished cut with dead-on accuracy.

The panel-cutter consists of two parts: a hardboard *base* that serves as a platform for the saw and a wood *fence* that guides the saw. (See drawing below.)

Here again, a *reference edge* that indicates the path of the saw blade is used to align the jig. After positioning this edge on the layout line, the panel-cutter is clamped to the workpiece. Then, with the saw riding

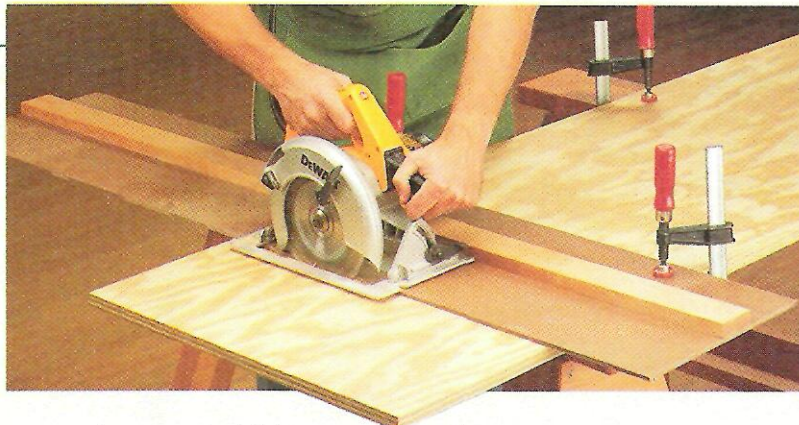

◀ **Panel-Cutter.**
Quick setups and accurate cuts. That's what you get with this simple panel-cutting jig.

against the fence, the blade cuts precisely along the reference edge, as shown in the detail below.

Note: You may want to make *two* panel-cutters: a 48"-long jig for cross-cutting full sheets of material and a

96"-long version to use when ripping.

Either way, start by gluing the fence to an extra-wide base. Then with the base of the saw riding against the fence, trim off the waste to create the reference edge. 🛠️

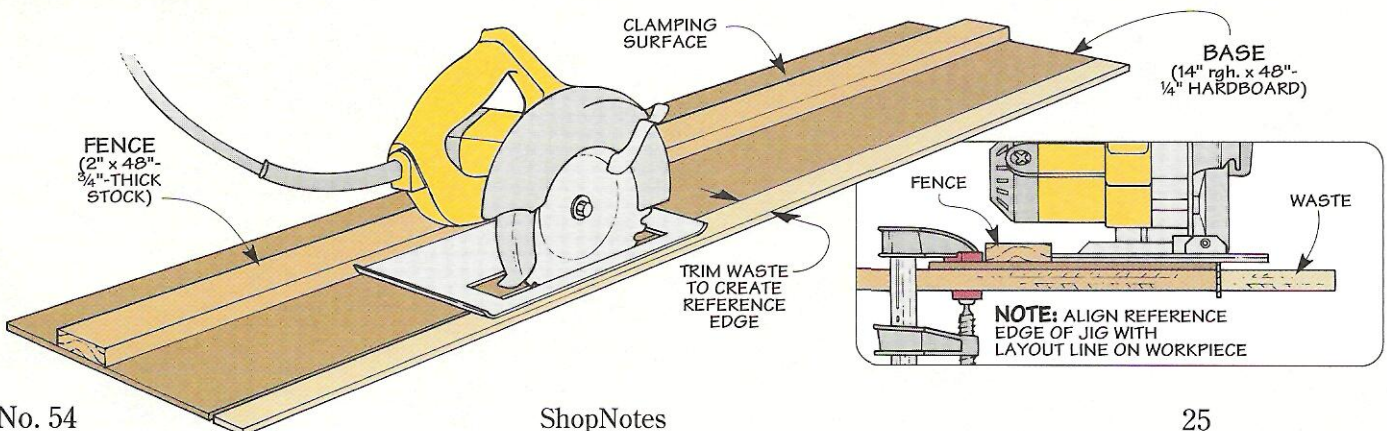

Power Cord Caddies

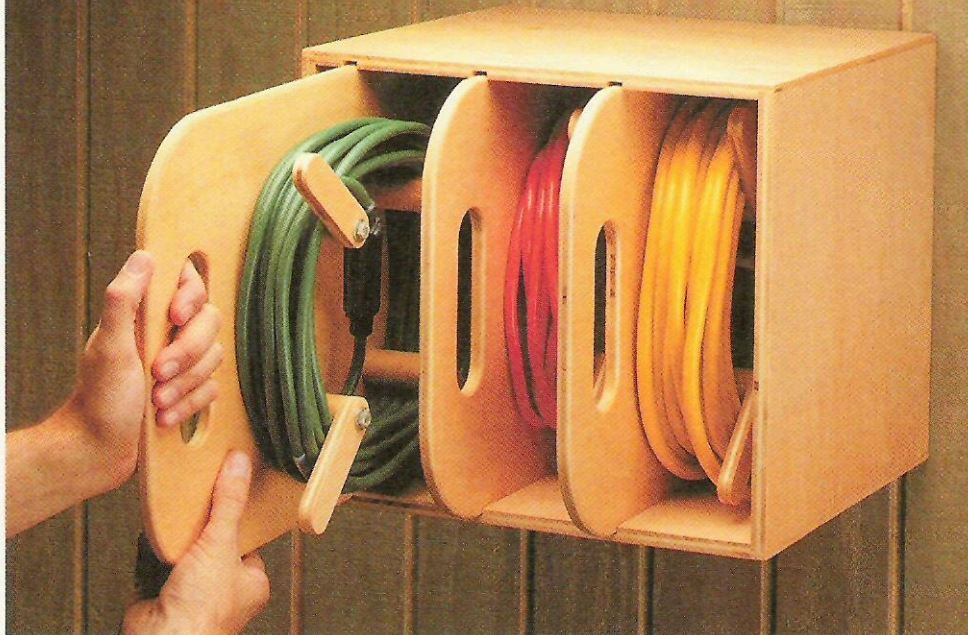

Tired of tangled power cords? Keep them coiled with these pull-out caddies.

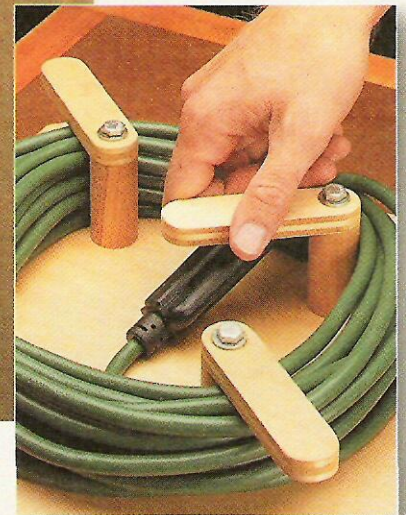

This is one project that makes me wonder why I didn't build it sooner — a simple storage system that keeps my power cords neatly coiled until I'm ready to use them.

To keep each cord from getting tangled up, it's wrapped around a set of four turnbuttons mounted to a plywood caddy. To remove a cord, just rotate the turnbuttons, as shown in

the inset photo. Once a job is done, flip the turnbuttons around, wind up the cord, and slip the caddy into a storage cabinet. Or if you prefer, hook the caddy on a wall-mounted hanger as shown on page 27.

CADDIES

I began by making *three* caddies, one for my 25, 35, and 50-foot power cords.

Back – Regardless of the cord length, the *back* (A) of each caddy is identical (Figure 1). It's just a piece of $\frac{1}{2}$ " plywood with a large handhold near the top. Notice there's a large radius on the two upper corners. (I didn't want any sharp corners sticking out.) It's also a good idea to "knock off" the lower corners to make it easy to slip the caddy into the cabinet.

Turnbuttons – Once the back of each caddy is complete, you're ready to add the four *turnbuttons*. As you can see in Figure 1, each turnbutton consists of two parts: a *post* made from a dowel and a *plywood arm*.

Posts – The *posts* (B) create a form to wrap the power cord around. To avoid getting a kink in the cord, I wanted it to bend gently around the posts, so I used large (1"-dia.) dowels.

As for length, a 2"-long dowel provided enough room under the arm to hold my two shortest power cords. But for the 50-foot cord, I cut 2 $\frac{1}{2}$ "-long dowels for extra clearance.

Arms – To complete the turnbuttons for each caddy, the next step is

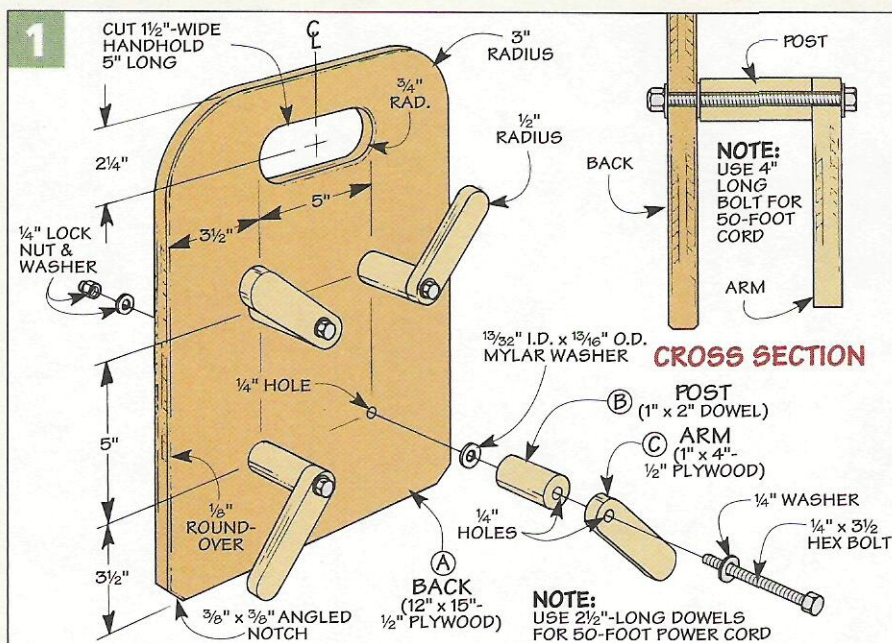

to make the four *arms* (C). These are strips of 1/2" plywood with curved ends to avoid "catching" the power cord. (I cut a 1/2" radius to match the shape of the dowels.)

After gluing an arm to each post, you can attach the turnbuttons to the caddy. Each one is held in place with a bolt and lock nut, as shown in the Cross Section in Figure 1.

That sounds simple enough. But how do you center the hole for the bolt on the dowel? And since you'll be drilling through end grain, how do you keep the bit from wandering?

To do that, I used an old trick. Start by drilling a hole for the dowel in a scrap piece that's clamped to the drill press table (Figure 2a). Then without moving the table, chuck in a 1/4" brad point bit and stick the dowel in the hole (Figure 2).

This automatically centers the bit on the dowel. Now use a slow, steady feed rate to drill the hole and keep the bit from veering off course.

Assembly - Once the holes are drilled, it's just a matter of assembling the turnbuttons. Notice in Figure 1 that there's a mylar (or nylon) washer installed between each post and the caddy. It allows the turnbutton to pivot freely.

CASE

With the caddies completed, I built a case to hold them. It's just an open

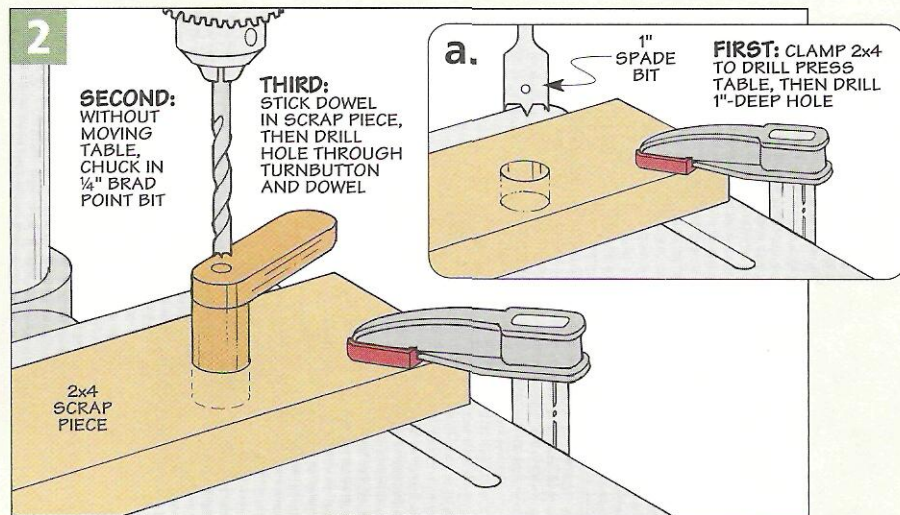

box that lets me slide the caddies in and out like books on a shelf.

Construction - With the exception of a hardwood cleat running along the back, the case is made entirely of 1/2" plywood. To simplify things even more, it's held together with ordinary rabbet joints and nails.

Top & Bottom - The first step is to cut the *top* and *bottom* (D) of the case to size (Figure 3). Then to accept the sides of the case, you'll need to rabbet both ends of each piece, as shown in Figure 3a.

In addition to the rabbets, there are three dadoes in each piece that guide the caddies in and out of the case. Although all these dadoes are evenly spaced, the opening that's formed on the *right* side is larger. It

provides the extra room that's needed for my 50-foot power cord.

Sides - Once the dadoes are completed, you can add the *sides* (E) of the case. After cutting these pieces to size, gluing and clamping the case together is a pretty routine operation. Just be sure that it's square so the caddies don't bind. Then drive in finish nails to strengthen the case.

Mounting Cleat - Finally, to provide a way to hang the case on the wall (and to create a "stop" for the caddies when they're slid into place), I added a *mounting cleat* (F). It's a strip of 3/4"-thick hardwood that fits between the sides. After pre-drilling mounting holes, just glue and nail the cleat in place, hang the case on the wall, and slide in the caddies.



▲ To hold a single caddy, an L-shaped wood block with a groove in the top provides a handy, wall-mounted hanger.

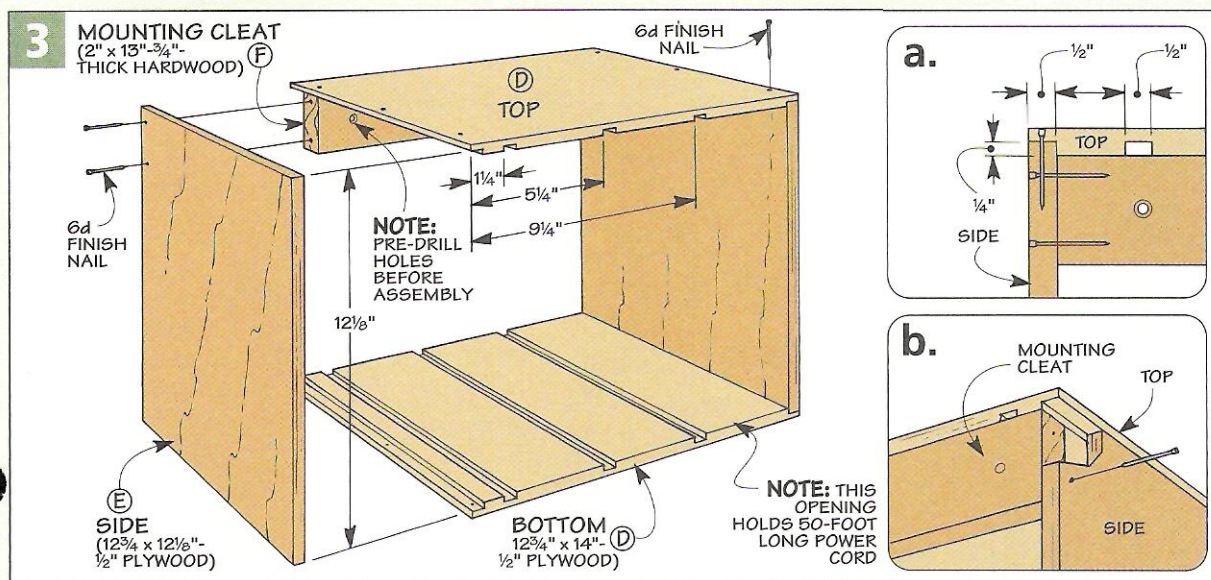

Classic Heirlooms from a Basement Shop

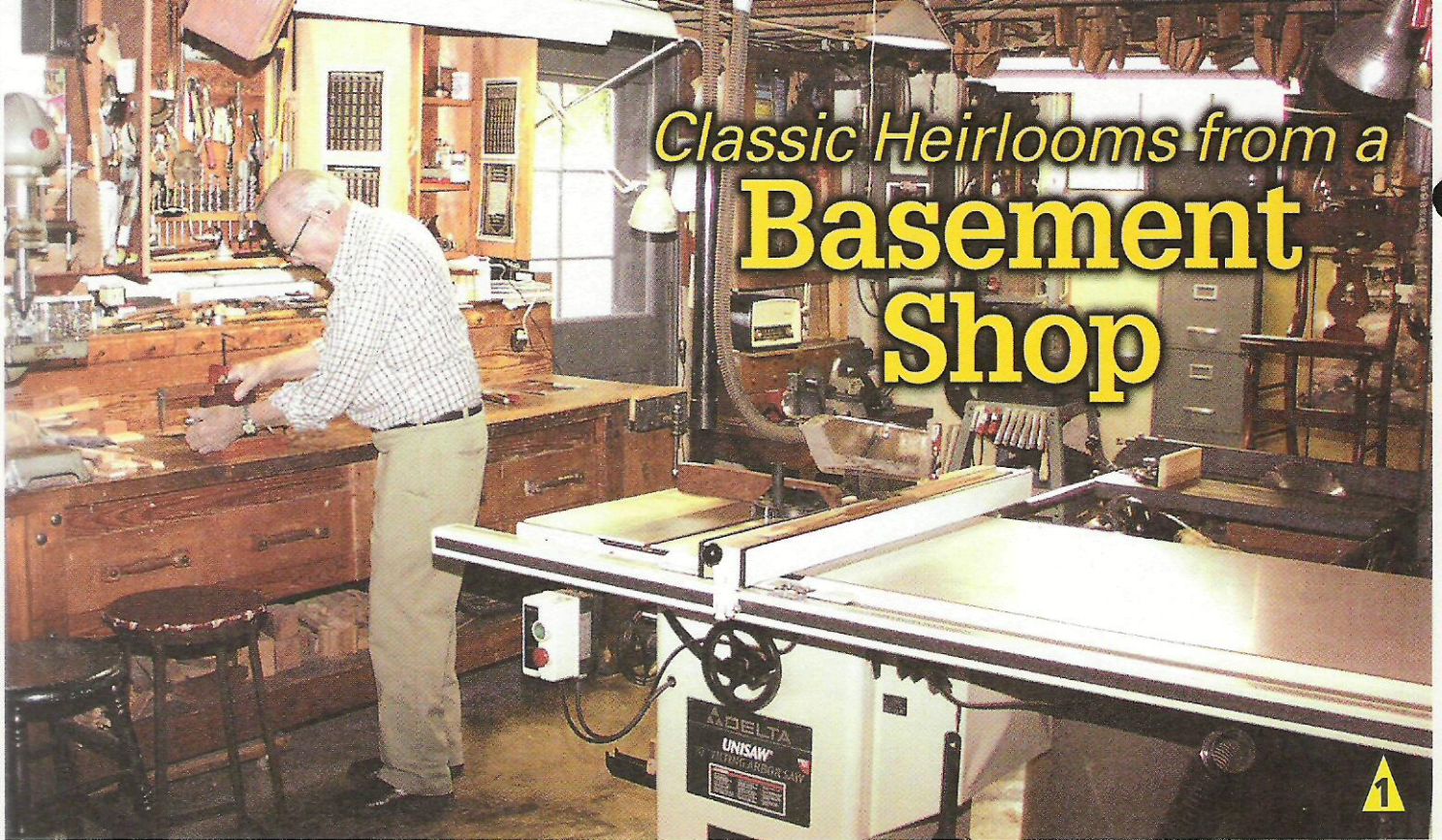

Build classic 18th century-style furniture in a basement? No problem.

One thing I've always enjoyed is visiting other woodworkers' shops. What better way to pick up new ideas for my own shop?

So I was intrigued when I heard about George Reid, a woodworker in Ohio who has been building fine furniture in his basement shop for over fifty years now. When I called him to ask about his shop, he said, "It's nothing fancy, but you're welcome to take a look." So I jumped at the

chance like a bass on a June bug.

Walking down the steps into George's shop, my first impression is it didn't *feel* like a basement. As you can see in the photo above, it's warm and cozy with lots of natural light. The tools are polished with use. And everything is in its place.

If not for a new table saw, the shop is pretty much like I'd have expected it to look in 1947, back when George started his woodworking business.

Classic Heirlooms – Ever since then, George has specialized in building and restoring 18th century-style furniture — tall chests of drawers with intricate, hand-carved details, elegant tables and chairs with graceful cabriole legs, and finely crafted desks with inlays and highly-figured veneer. (We've shown two examples of his craftsmanship at left.)

Miniatures – As remarkable as they are, there were some other projects in George's house that intrigued me even more. Once a piece of furniture is completed, he often builds a *miniature* version that's accurate in every detail (usually $\frac{5}{16}$ " to 1" scale).

If you look at the two miniatures shown at the top of page 29, you can see that this is definitely a labor of love. (Altogether, he spent about 280 hours building the highboy, and the chair took about 175 hours.)

But there's a practical purpose for these miniatures as well. They make it easy for customers to select the style of furniture they want — without taking up a lot of room in his house.

Shop Layout – Having enough room in the house is one thing. But what about the space in his *shop*? As with many basement shops, it's



▲ **Custom Classics.** Originally, George built this elegant Queen Anne lowboy (left) and Newport block and shell desk (right) to furnish his house. But these pieces also serve as an incredible "showroom" that helps customers select the style of furniture they want.

shared with a washer and dryer, furnace, and hot water heater. (See the Shop Layout Plan below.) So besides having to work around these household functions, George faced a number of other challenges that go along with setting up a basement shop.

Access – One of the biggest considerations was access to the shop. At first, the only way to haul lumber in (or carry completed projects out) was a steep, narrow stairway leading down from the house.

The solution was to install a wide door in the exterior (north) wall of the shop. This required excavating for a set of concrete steps. But it made such a dramatic improvement, it was worth the effort. As an added benefit, a large window in the door allowed even more light to filter in.

Assembly Area – The door opens directly into the main assembly area of the shop. It's a long, narrow space, but it's large enough to handle every project George builds. Once he even assembled a 12½-foot long dining table in this area.

Temporary Worksurface – This open space also comes in handy when he needs a temporary work-surface. On the day I visited, he had set up a table using sawhorses and plywood to work on a chair that needed repair. (See photo below.)



▲ **Miniature Marvels.** From the hand-carved finials and rosettes on this 27"-tall highboy (at left and inset) to the cabriole legs of a Chippendale chair (right), George Reid crafts miniatures that are accurate in every detail.

Workbench – A few steps away from the assembly area is the heart of George's shop — a massive workbench with thick slabs of oak for a top. The bench provides solid support for carving. To provide access to three sides of the carving, he clamps it to a thick chunk of lumber that overhangs the front of the bench like a diving board.

If you look at the photo on page 28, you can see a row of large drawers under the bench that hold portable power tools and supplies. Nothing out of the ordinary there.

But there is one thing about this bench that's a bit unusual — a tall riser unit in back.

Riser Unit – This built-in unit serves several different purposes. For starters, it prevents things from falling off the back of the bench. Plus it's a handy shelf that keeps the benchtop from getting cluttered up.

To provide additional storage, there's a row of small drawers built into the riser unit. And finally, electrical outlets installed in the back of the unit make it a snap to plug in portable power tools.

Shop Tours
ON THE WEB

Want to see more woodworkers' shops?

Or have your own shop featured in ShopNotes?

Visit us on the Web at ShopNotes.com

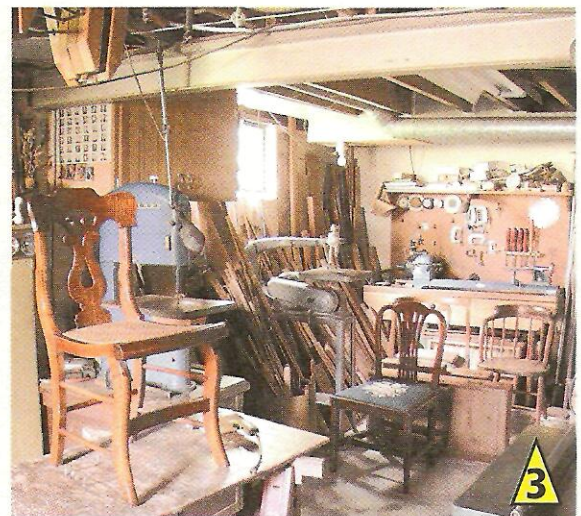
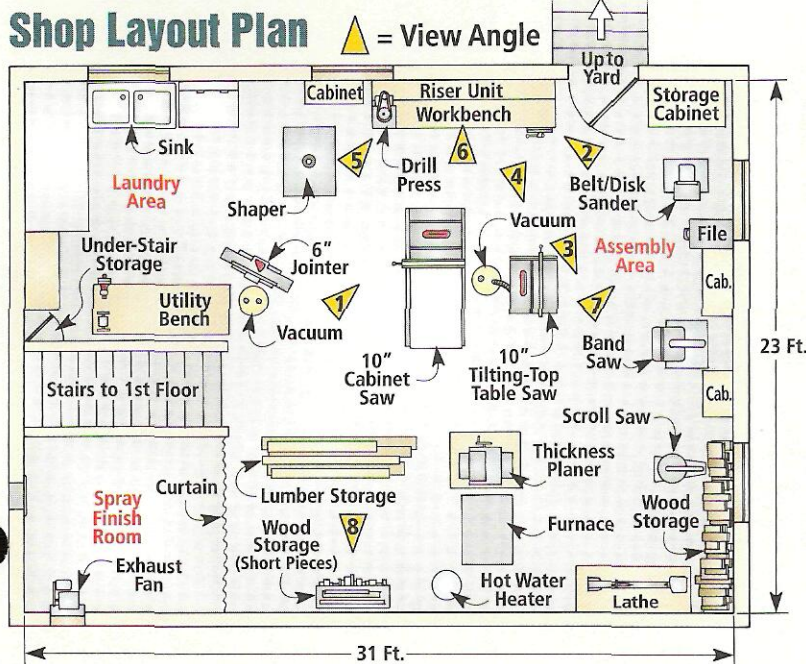

▲ **Repair & Restoration.** An important part of George's business is repairing damaged furniture or restoring a finish as with this late Empire chair.

Tooling Up

It's obvious that George Reid pays special attention to every piece of furniture he builds or repairs. That's also true for the *tools* he uses to do it.

From the smallest carving gouge to his largest power tool, he keeps each one clean, sharp, and ready to use. "Look, there's not a single mark from a drill bit on this drill press table," he points out with a caretaker's pride. That explains why the tools he purchased in the 1940's and 50's are the ones he still uses today.

Vintage Tools – Two of these vintage tools are shown above. A tilting-top table saw handled all the work until he acquired a Delta Unisaw a few years ago. (He still uses the old saw to build miniatures.) And a 1939 drill press provided reliable service for a decade even *before* he set up shop.

Stock Preparation – In addition, a heavy-duty, 6" jointer and a 12" planer take care of the job of getting lumber straight, flat, and square. As you can see in the Shop Layout Plan (page 29), the jointer sits at an angle. This provides a long "run" so he can work with long boards. Also, a shop-made, mobile base lets him roll the planer to a place where there's enough clearance for long pieces.

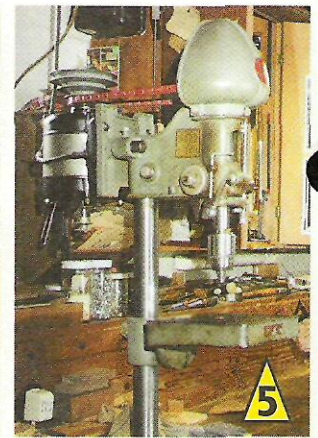

▲ **Vintage Tools.** This 10" tilting-top table saw (shown at left) has been the workhorse of George's shop since 1947. Like the old benchtop drill press (right), it appears to be in the same condition as when it was purchased.

Shaping Tools – One thing that surprised me is George doesn't own a router. To create the elaborate moldings for this style of furniture, he uses a shaper. As for the curved arms and legs, intricate fretwork, and turned ornaments, a band saw, scroll saw and lathe are indispensable.

Hand Tools – But the thing that sets George's work apart are the *hand-made* details: graceful cabriole legs, shell carvings, and dovetailed drawers. That's where his hand tools come in. To provide easy access to these tools, they're stored in a cabinet behind his bench. (It's one of the storage solutions shown below.)

Finishing – Another important "tool" is the spray system he uses to apply a lacquer finish. A converted

coal room serves as a finishing area. To seal it off, he pulls a curtain across the room. Then, in order to vent the fumes outside, he flips on a squirrel-cage blower that was recycled from an old furnace.

Dealing with Dust – One final thing I was curious about is how he deals with dust. The answer is simple — two shop vacuums. Depending on whether he's making a light cut or hogging off a lot of material, he hooks up one (or both) vacuums to collect the chips.

Conclusion – I know, it's a fairly ordinary solution. But the point is it works. I guess you could say it's just one more example of how a very ordinary shop is all George needs to produce his extraordinary furniture. ▲

Storage Solutions

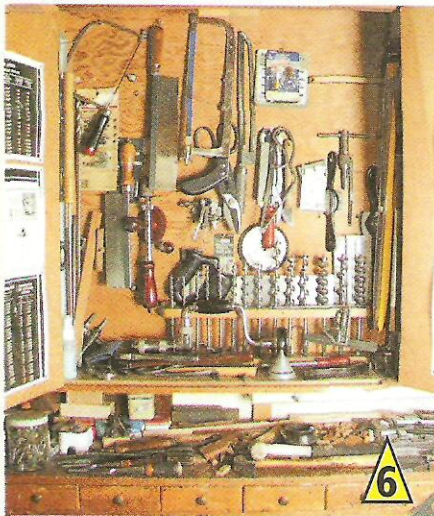

▲ **Tool Cabinet.** A wall-mounted cabinet hanging behind George's workbench provides easy access to his hand tools.



▲ **Overhead Storage.** To take advantage of the space overhead, he hangs molding planes and handscrews on the floor joists.

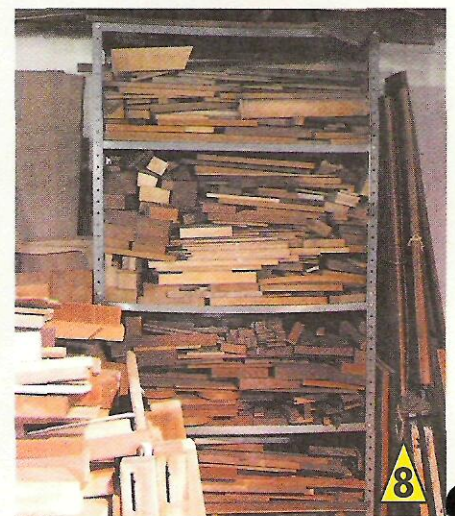

▲ **Metal Shelving.** An inexpensive, metal shelving unit holds short pieces of wood that will be used to build his miniatures.

Sources

PRODUCT INFORMATION

ShopNotes Project Supplies is offering some of the hardware and supplies needed to build the projects in this issue.

To place an order for the kits shown on this page, call:

800-347-5105

(Key Code: SN 54)



Project Kits ON THE WEB

Get ShopNotes' Kits Quick
Visit us on the Web at ShopNotes.com



▲ Marking Gauge

Spend a morning in the shop and build a precision hand tool you can use for a lifetime. That's the idea behind this *ready-to-assemble* kit for the Marking Gauge that's shown on page 6.

This kit contains all the pre-cut hardwood pieces you need to make the Marking Gauge. Plus it includes all the brass hardware. All you need to supply is an *X-ACTO* blade and the drafting lead.

MARKING GAUGE KIT
7512-550-SN54.....\$29.95

▲ Electrical Supplies

There's nothing mysterious about tuning up a portable power tool (page 12). All it takes is a couple of electrical testing tools and some readily available supplies. All the tools and supplies shown above are available from hardware stores, home centers, or stores that sell electronic supplies like *RadioShack*.

▲ Roll-Around Tool Cart

The Roll-Around Tool Cart featured on page 16 is a great way to organize your portable power tools and keep them right at hand.

ShopNotes Project Supplies is offering a complete hardware kit to build the tool cart. This kit has all of the hardware that you'll need including the heavy-duty casters, hinges, pulls, magnetic catches, and screws. All you need to supply is the plywood, hardboard, and hardwood.



ROLL-AROUND TOOL CART KIT
6854-100-SN54.....\$115.95

ON-LINE CUSTOMER SERVICE

- Access information about your subscription account.
- Find out if your payment has been received.
- Change your mailing address or your email address.
- Renew your subscription.
- Pay your bill.

www.ShopNotes.com

WoodNet

- 101 Woodworking Tips Online
- Woodworking Techniques
- Project plans you can download
- WoodNet Forum
- Power Tool Reviews

www.WoodNet.net

STATEMENT OF OWNERSHIP, MANAGEMENT, AND CIRCULATION (Required by 39 U.S.C. 3685)

1. Publication Title: *ShopNotes*. 2. Publication No.: 1062-9696 3. Filing Date: September 15, 2000. 4. Issue Frequency: Bimonthly. 5. No. of issues published annually: 6 (six). 6. Annual subscription price: \$21.94. 7. Complete mailing address of known office of publication: 2200 Grand Avenue, Des Moines, (Polk County), Iowa 50312-5306. 8. Complete mailing address of the headquarters or general business offices of the publisher: 2200 Grand Avenue, Des Moines, (Polk County), Iowa 50312-5306. 9. Full names and complete mailing addresses of publisher, editor, and managing editor: Publisher: Donald B. Peszke, 2200 Grand Avenue, Des Moines, Iowa 50312; Editor: Tim Robertson, 2200 Grand Avenue, Des Moines, Iowa 50312. 10. Owner: August Home Publishing Company, 2200 Grand Avenue, Des Moines, Iowa 50312; Donald B. Peszke, 2200 Grand Avenue, Des Moines, Iowa 50312. 11. Known bondholders, mortgagees, and other security holders owning 1 percent or more of total amount of bonds, mortgages or other securities: None. 12. (Does not apply.) 13. Publication Title: *ShopNotes*. 14. Issue Date for Circulation Data Below: July/August 2000 (#52) 15. Extent and nature of circulation:

	Average no. copies each issue during preceding 12 months	Average no. copies of single issue published nearest to filing date
A. Total number of copies (net press run)	216,250	206,025
B. Paid and/or requested circulation:		
1. Paid/requested outside-county mail subscriptions stated on Form 3541	172,182	162,860
2. Paid in-county subscriptions	0	0
3. Sales through dealers and carriers, street vendors, counter sales, and other non USPS paid distribution	19,456	18,838
4. Other classes mailed through the USPS	0	0
C. Total paid and/or requested circulation	191,638	181,698
D. Free distribution by mail, samples, complimentary, and other free copies:		
1. Outside-county as stated on Form 3541	140	131
2. In-county as stated on Form 3541	0	0
3. Other classes mailed through the USPS	0	0
E. Free distribution outside the mail (carriers or other means)	0	0
F. Total free distribution	140	131
G. Total distribution	191,778	181,824
H. Copies not distributed	24,472	24,201
I. Total	216,250	206,025
J. Percentage Paid and/or requested circulation	99.93%	99.93%

16. Publication of Statement of Ownership. Will be printed in the Nov./Dec. 2000 (#54) issue of this publication.
17. I certify that all information furnished on this form is true and complete. (Signed) Tim Robertson, Editor

On occasion, we allow companies whose products and services may be of interest to you to send advertising mail to our subscribers. We are careful to choose ethical companies that have information of genuine interest to our subscribers. Most of our subscribers appreciate receiving these materials. However, if you prefer to have your name deleted from the mailing list made available to other companies, please write to us at ShopNotes, 2200 Grand Avenue, Des Moines, IA 50312

Scenes from the Shop

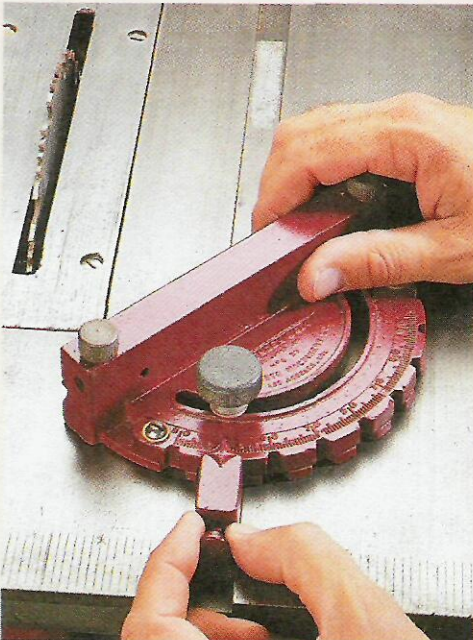
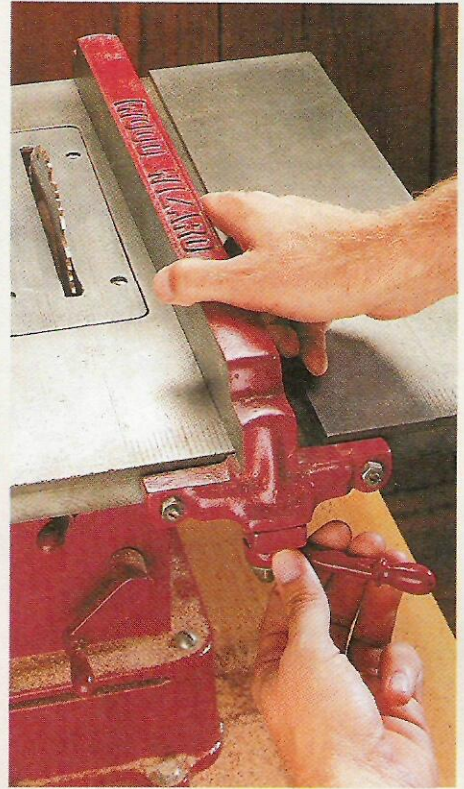
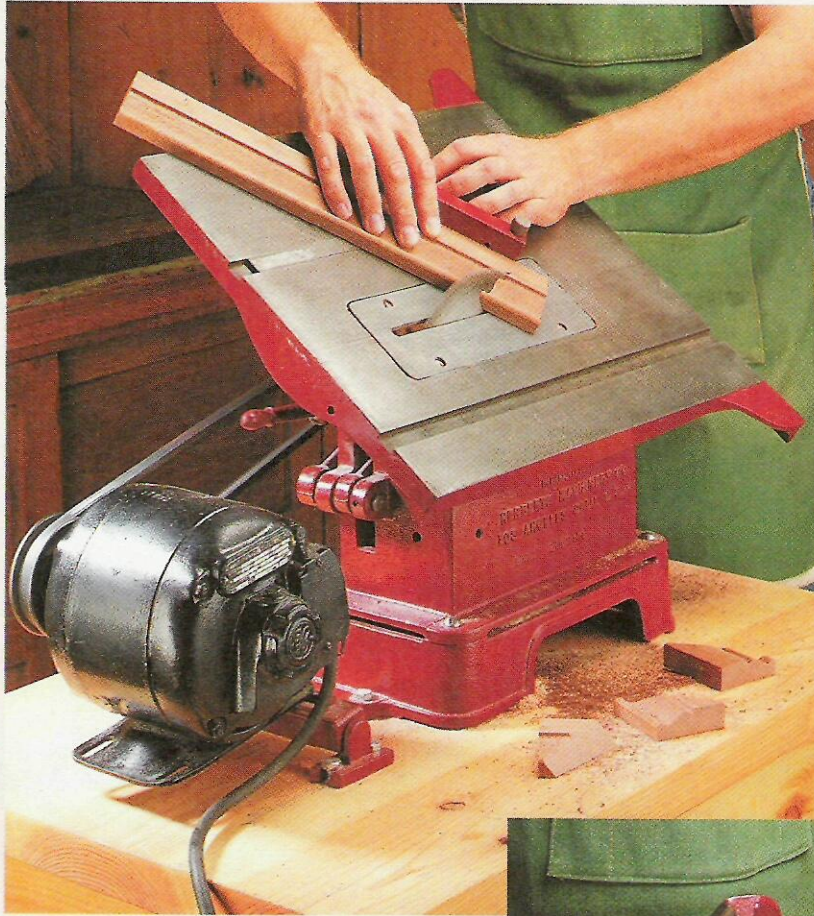

▲ Manufactured by the Herbert's Machinery Company in the 1930's, this 8" tilting-top table saw still provides reliable service. (See upper left and lower right photos.) With a

self-squaring rip fence (upper right) and an "Auto Index" miter gauge (lower left), this benchtop saw is a precision tool that lives up to its name — the Wood Wizard.

ShopNotes Cutting Diagram

Roll-Around Tool Cart

Materials

Case

A Sides (2)	$15^{13}/16 \times 26^{1}/4$ - $3/4$ Plywood
B Divider (1)	$15^{9}/16 \times 26^{1}/4$ - $3/4$ Plywood
C Skins (4)	16 rgh. x $26^{1}/2$ rgh. - $1/4$ Hdbd.
D Top/Bottom (2)	$15^{9}/16 \times 27$ - $3/4$ Plywood
E Back (1)	$26^{1}/4 \times 27^{1}/2$ - $1/4$ Hardboard

Doors/Worksurface

I Door Panels (2)	$13^{1}/2 \times 25^{11}/16$ - $3/4$ Plywood
J Edging	$1/4 \times 3/4$ (20 Linear Ft.)
K Trim Strip	$3/16 \times 3/4$ (7 Linear Ft.)
L Top Panel (1)	$16^{3}/4 \times 28$ - $3/4$ Plywood

Tool Trays

F Bottom (6)	$12^{13}/16 \times 15^{9}/16$ - $1/4$ Hardboard
G Front/Back (12)	$3/4 \times 2 - 11^{1}/4$
H Sides (12)	$3/4 \times 2 - 15^{9}/16$

$1/4 \times 48 \times 96$ HARDBOARD



3/4 X 48 X 96 BIRCH PLYWOOD

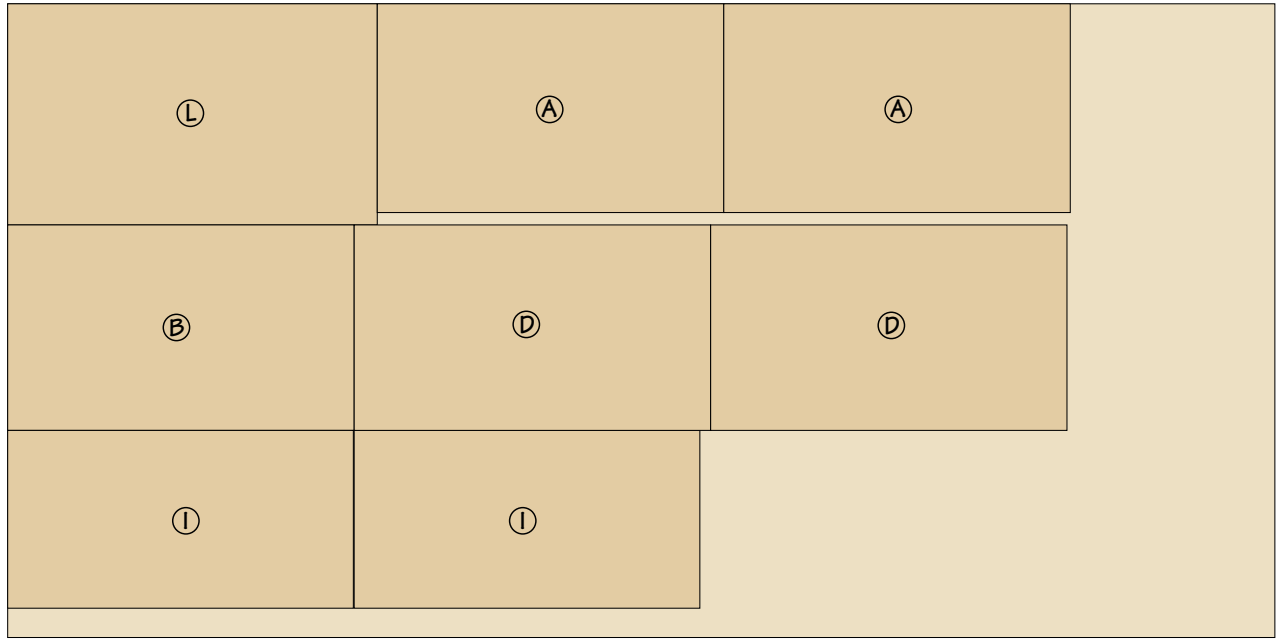

3/4 X 5 X 96 HARDWOOD

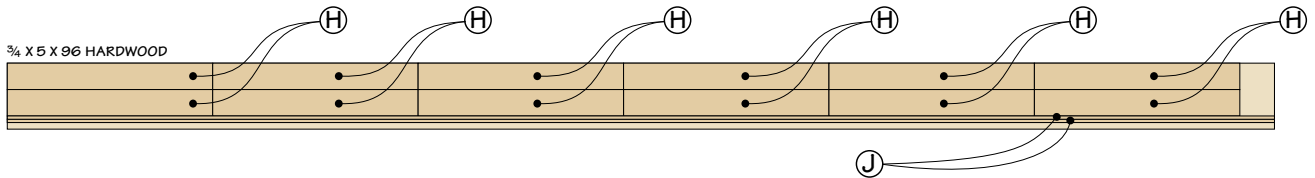

3/4 X 5 X 96 HARDWOOD

