

LEARN THE
SECRETS TO USING
Polyurethane Glues

TOUR A ONE-OF-A-KIND COUNTRY SHOP

ShopNotes®

Vol. 10

Issue 58

Top-Notch

Miter Saw Station

*It's accurate,
adjustable,
& portable*

**Tool
Storage**

*A must-have
organizer for all
your cordless tools*

**Molding
Head Cutters**

*Make your own unique
moldings on a table saw*



ShopNotes®

Issue 58

July 2001

PUBLISHER Donald B. Peschke

EDITOR Terry J. Strohman

ASSOCIATE EDITORS Bryan Nelson

Vincent Ancona

ART DIRECTOR Cary Christensen

SR. GRAPHIC DESIGNER Kurt Schultz

SENIOR ILLUSTRATORS Roger Reiland

Mark Higdon

CREATIVE RESOURCES

Creative Director: Ted Kralicek • *Project Developer:* Ken Munkel • *Sr. Project Designer:* Kent Welsh • *Project Designers:* Chris Fitch, Craig Iseke • *Shop Craftsmen:* Steve Curtis, Steve Johnson • *Senior Photographer:* Crayola England

SPECIAL PUBLICATIONS

Corp. V.P.: Douglas L. Hicks • *Art Director:* Douglas A. Flint • *Sr. Graphic Designer:* Chris Glowacki • *Graphic Designers:* Vu Nguyen • *Associate Editor:* Craig Ruegsegger • *Asst. Editors:* Joel A. Hess, Joseph E. Irwin

CIRCULATION

Subscription Services Director: Sandy Baum • *New Business Dir.:* Wayde Klingbell • *Circulation Marketing Analyst:* Kris Schlemmer • *Assoc. Circ. Marketing Analyst:* Paula DeMatteis • *Renewal Manager:* Paige Rogers • *Sr. Graphic Designers:* Mark Hayes, Robin Friend • *Billing & Collections Mgr.:* Rebecca Cunningham • *Multimedia Promotion Mgr.:* Rick Junkins • *Promotion Analyst:* Patrick Walsh

CORPORATE SERVICES

V.P. of Finance: Mary Scheve • *Controller:* Robin Hutchinson • *Sr. Accountant:* Laura Thomas • *Accounts Payable:* Mary Schultz • *Accounts Receivable:* Margo Petrus • *Prod. Dir.:* George Chmielarz • *Electronic Pub. Dir.:* Douglas M. Lidster • *Network Admin.:* Cris Schwanebeck • *Pre-Press Image Specialists:* Troy Clark, Minnette Johnson • *Office Mgr.:* Noelle Carroll • *New Media Mgr.:* Gordon C. Gaippe • *Multimedia Art Dir.:* Eugene Pedersen • *Technology Analyst:* Carol Schoeppler • *Web Content Mgrs.:* David Briggs, Sue M. Moe • *Web Designer:* Kara Blessing • *Professional Dev. Dir.:* Michal Sigel • *H. R. Asst.:* Kirsten Koele • *Receptionist:* Jeanne Johnson • *Mail Room Clerk:* Lou Webber

MAIL ORDER

Operations Director: Bob Baker • *Customer Service Mgr.:* Jennie Enos • *Warehouse Supr.:* Nancy Johnson • *Buyer:* Linda Jones • *Admin. Asst.:* Nancy Downey • *Tech. Rep.:* John Audette • *Cust. Serv. Reps.:* Anna Cox, Tammy Truckenbrod, Deborah Rich, April Revell, Valerie Riley, Linda Stepp, Eddie Arthur • *Warehouse:* Sylvia Carey, Dan Spidle, Sheryl Knox, Al Voigt

WOODSMITH STORE

Manager: Dave Larson • *Asst. Mgr.:* Tim Thelen • *Sales Staff:* Wendell Stone, Jim Barnett, Kathy Smith, Larry Morrison, Harold Cashman, Gregory Kauzlarich, Mark Johnson, Joe Kucera • *Office Manager:* Vicki Edwards

ShopNotes® (ISSN 1062-9696) is published bimonthly (Jan., March, May, July, Sept., Nov.) by August Home Publishing, 2200 Grand, Des Moines, IA 50312.

ShopNotes® is a registered trademark of August Home Publishing. © Copyright 2001 by August Home Publishing. All rights reserved. Subscriptions: Single copy: \$4.95. One year subscription (6 issues), \$27.95. Canada/International add \$10 per year, U.S. funds.

Periodicals Postage Paid at Des Moines, IA and at additional mailing offices.

Postmaster: Send change of address to ShopNotes, P.O. Box 37103, Boone, IA 50037-2103.

Subscription Questions? Write to: ShopNotes Customer Service, P.O. Box 842, Des Moines, IA 50304-9961. Or call 1-800-333-5854, 8:00 am to 5:00 pm, Central Time, weekdays. FAX 515-283-0447

E-Mail: ShopNotes@shopnotes.com

Internet: http://www.shopnotes.com

PRINTED IN U.S.A.

EDITOR'S NOTE

Cutoffs

Not too long ago, the only people who owned a power miter saw were professional cabinet-makers and trim carpenters. And their choices were limited to just a few models. Not any longer.

Take a trip through the tool aisle at your local home center, and you'll probably find a dozen different models of power miter saws. Some tool catalogs have even more. And I counted over 35 different models on a large tool retailer's web site.

It's easy to see why these saws are so popular. They make fast, accurate miter cuts, and they're becoming more affordable all the time.

If there is a drawback to these saws, it's that the table is relatively small. Which makes it difficult to support long workpieces.

To solve this problem, we designed a new miter saw station with sliding support blocks that can be locked into position wherever you need them. Then, we added a quick-

release fence system with a sliding stop block for accurate cuts time after time. And best of all, the whole system works just as well outside the shop on a pair of sawhorses as it does in the shop. Check out the article on page 16 and see for yourself.

Help Wanted. One of the reasons that we're able to feature projects like this is we have talented designers that turn ideas into great projects. And now we're looking for another project designer to join the August Home team here in Des Moines.

This position requires an in-depth knowledge of furniture design, wood-working joinery, and home construction. And the ability to generate computer-aided drawings and supervise project construction.

If this sounds right for you, please contact: Ted Kralicek, August Home Publishing Co., 2200 Grand Ave., Des Moines, IA 50312 Fax (515) 282-6741. For more information see our job openings at www.augusthome.com.

Terry

Be included, as a part of the Woodworking Shop Tours

On the Web

Visit other ShopNotes subscribers' workshops and see photos of the shop projects they've built. It's all online at Woodworking Shop Tours on the ShopNotes web site:

www.ShopNotes.com

We want you to be part of our shop tours! To submit photos of your favorite ShopNotes projects or views of your shop, just follow the instructions you'll find on our web site.

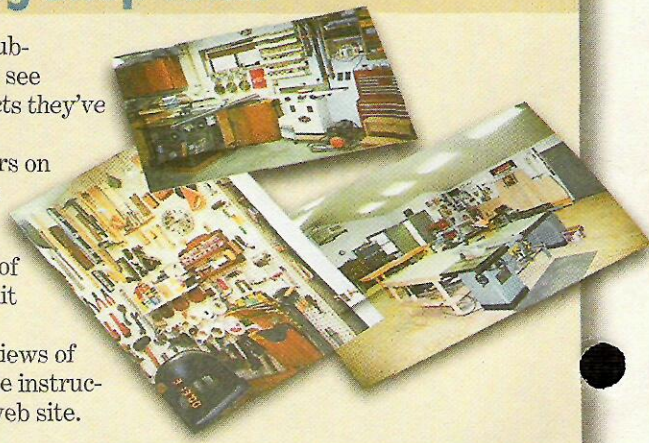

Contents

Features

Cordless Tool Storage Cabinet _____ 6

Here's a project to help you keep it all together. It's the perfect solution for keeping your cordless tools, chargers, and accessories organized and ready to go.

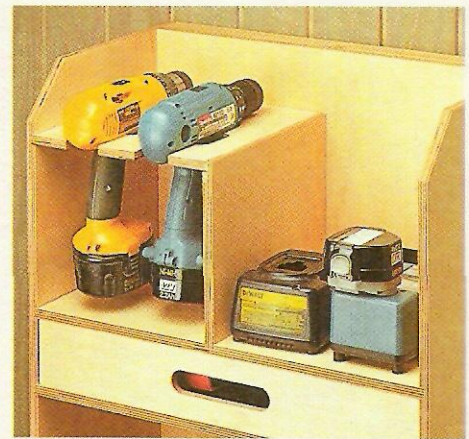

Cordless Tool Storage page 6

Polyurethane Glue _____ 10

If you think that wood and water don't mix, you're in for a surprise. In this article, we give you a few tips and techniques we've learned in our shop about working with polyurethane glue.

Country Shop _____ 12

Take a tour of a country dream shop. It has plenty of wide open space, an impressive collection of power tools, and ideas you can put to use in your own shop.



Miter Saw Station page 16

Miter Saw Station _____ 16

Whether you're working in the shop or on site, this miter saw station offers both accuracy and portability. Plus, it has a movable fence system that quickly adjusts to match the length of your stock.

Molding Heads _____ 24

Your table saw is already a workhorse in the shop. Adding a molding head makes it even more versatile. Here's how to get the most out of a molding head and a set of cutters.



Molding Heads page 24

Molding Head Fence _____ 28

Attach this auxiliary fence and guard to your rip fence to make smoother, safer cuts with a molding head.

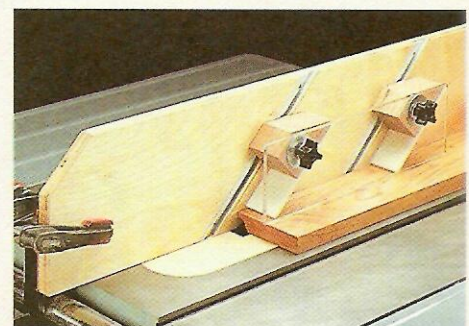

Molding Head Fence page 28

Departments

Readers' Tips _____ 4

Shop-tested tips to solve common woodworking problems.

Sources _____ 31

Mail-order sources and supplies to help you build the projects featured in this issue.

Readers' Tips

Folding Sawhorse

■ Sawhorses sure come in handy for a lot of tasks around the house. But since I have a small shop, I needed a sawhorse that wouldn't take up much storage space. So I came up with this design for a folding sawhorse. It's plenty strong and sturdy, but when it's not in use it folds up flat and can be stored against the wall, see inset photo.

I used "two-by" stock to build the sawhorses. Start by making a template to help lay out the angles on the legs, as shown in the detail drawing below. Then you can cut out the mitered ends using the template. After mitering the legs, cut a couple of notches in each leg to hold the rails and stretchers. To complete

the legs, drill a $\frac{3}{8}$ "-dia. hole near the top end of each leg for the mounting hardware that will be added later.

The rails of the sawhorse are beveled along the top edge to create a flat surface when the sawhorse is opened, see detail 'a'. The stretchers are simply cut to length. But notice that they are both a different length. This allows you to offset the legs so the sawhorse will fold up flat.

Once the rails and stretchers are cut to finished size, they can be attached to the legs with screws. The stretchers are positioned so that their ends are flush with the side of the legs. To determine the positioning for the rails, see detail 'b'.

Finally, the two halves of the sawhorse are connected with carriage bolts, washers, and lock nuts.

Scott Benjamin
Lakeville, Minnesota

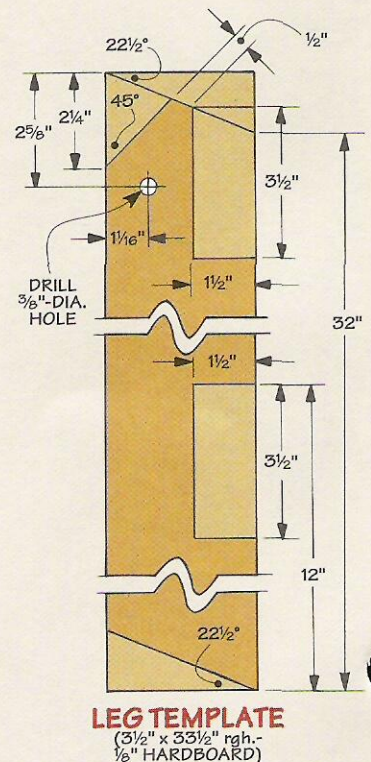
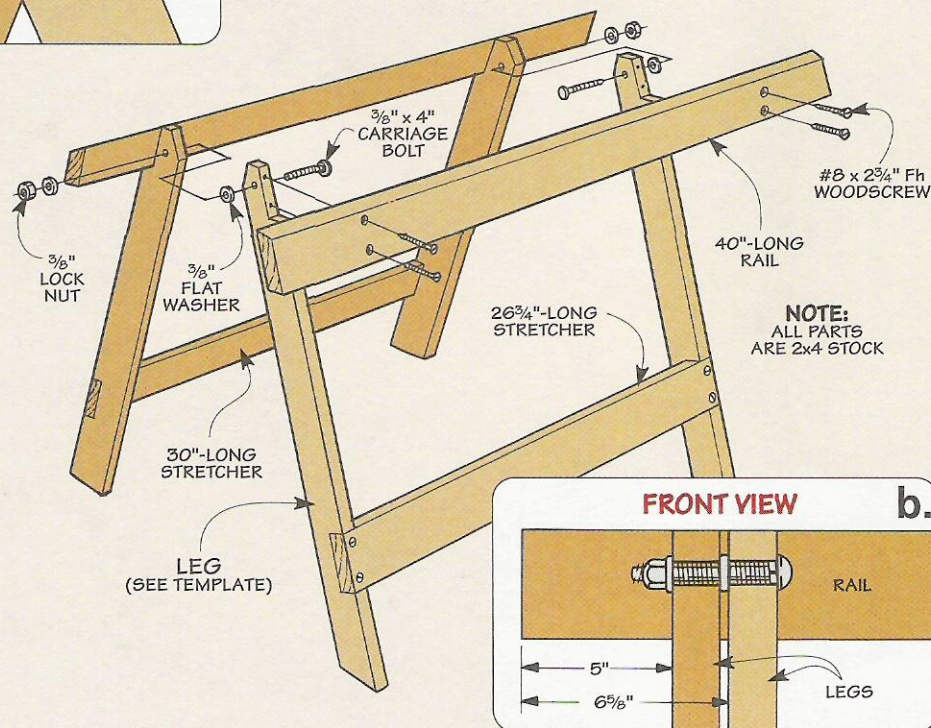
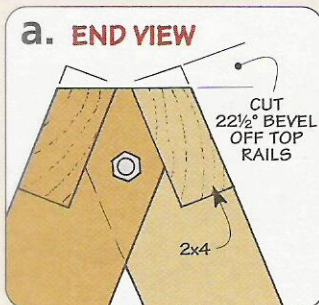

Air Compressor Base

■ I use a small “portable” air compressor in my shop. But despite the name, I find it cumbersome to carry this compressor around where I need it. So instead, I built a small, roll-around base for the compressor, see drawing.

The base is nothing more than a square piece of $\frac{3}{4}$ " plywood with a caster mounted at each corner (two swivel casters and two fixed). A small block of wood in each corner of the base provides a mounting surface for the caster. To keep the compressor from vibrating off the platform, cleats are added around the edges to create a frame.

*J. Thomas Timpano
Round Hill, Virginia*

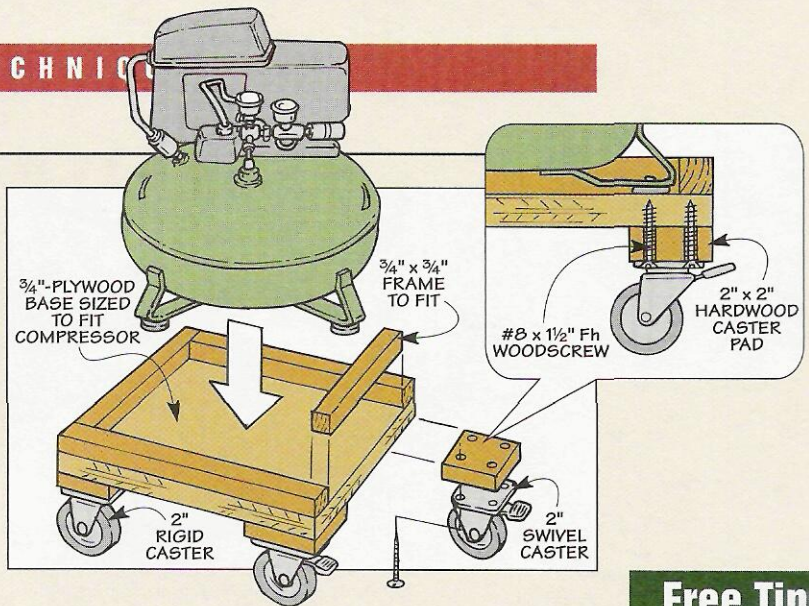

Vise on Lathe Stand

■ In order to make room in my small shop for a wood lathe that I recently purchased, I had to get rid of an extra workbench. While I didn't use the bench all that much, I really missed the machinist's vise that was attached to it. But then it dawned on me that I could still use the machinist's vise by simply mounting it to the tailstock end of the lathe, as shown in the drawing at right.

Not wanting to drill holes in the lathe bed, I mounted the vise to a plywood base and then fastened the base to the lathe with carriage bolts, knobs, and a couple of clamping blocks, see drawings at right. An alignment strip on the underside of the base assists in positioning the vise on the lathe bed.

Most of the time, I can just leave the vise attached to my lathe. When I need to use the full length of the lathe, it takes only a minute to undo the knobs and remove the vise.

*Anthony Diodati
Imperial, Pennsylvania*

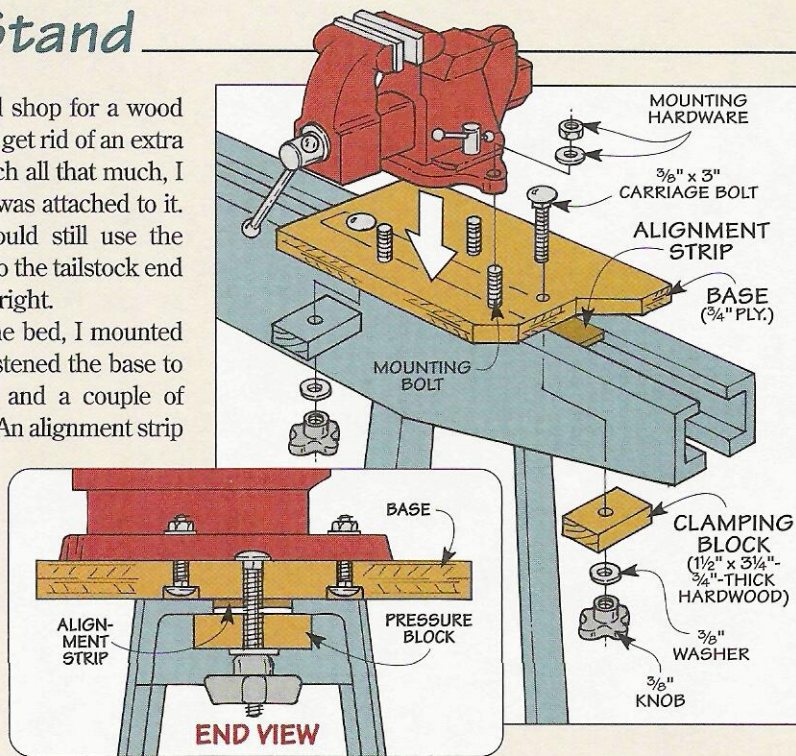

Free Tips ON THE WEB

Get more wood-working tips free.

Visit us on the Web at
ShopNotes.com

Sign up to receive
a free shop tip by
e-mail every week.

Quick Tips



▲ To prevent his shop vacuum from “sticking” to the floor, **William McKinney** of Richmond, KY attaches a couple of wood blocks.



▲ To help find cutoffs by length, **Crayola England**, of Des Moines, IA affixes a measuring tape to the front of her cutoff bin.

Send in Your Shop Tips

If you have a unique shop tip, we'd like to consider featuring it in one or more of our print or electronic publications.

We'll pay up to \$200 for a tip we publish. Just write down the tip and mail it to *ShopNotes*, Attn.: Readers' Tips, 2200 Grand Ave., Des Moines, IA 50312. Or FAX it to 515-282-6741, or send us an e-mail at shopnotes@shopnotes.com. Please include your name, address and daytime phone number in case we have any questions.

Cordless Tool Storage Cabinet

There's no doubt about it. Cordless tools are pretty handy to have around in the shop. Just grab your tool and go. But as convenient as they are to use, cordless tools don't completely eliminate the hassle of dealing with power cords. That's because they all come with a battery charger that still has to be plugged into the wall somewhere. And if you have more than one cordless tool, pretty soon your benchtop is strewn with batteries and chargers.

The idea behind this storage cabinet is to get the battery chargers off the top of the workbench and out of the way. It also provides a storage place for the tools so that you can find them when you need them. (Without a

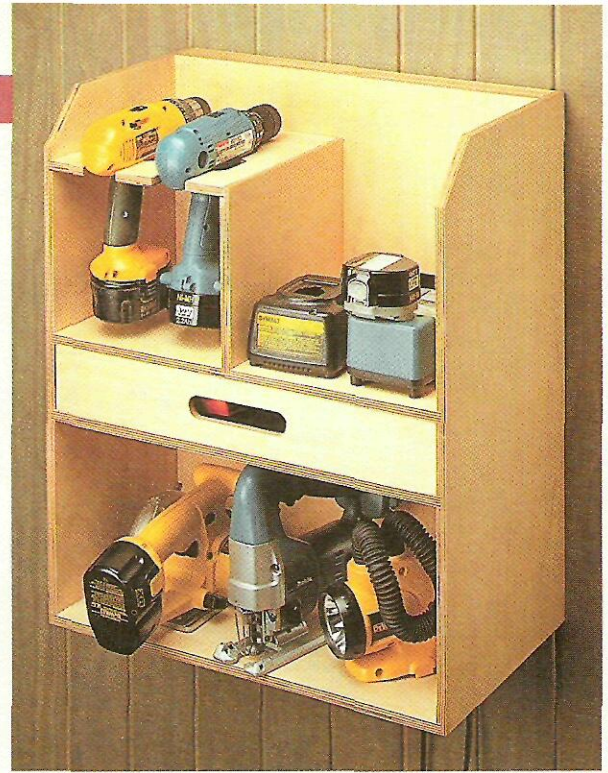

power cord to act as a leash, cordless tools seem to have a habit of "walking off" on their own.)

This cabinet is designed to hold a pair of drills and a couple of cordless saws, along with their battery chargers. But you can easily customize it to fit your own cordless tool storage needs. A

wide, shallow drawer in the middle of the cabinet provides the perfect place to keep saw blades, drill bits, or other accessories.

Case - As you can see by looking at Figure 1, the case of the cabinet is constructed entirely of 1/2" plywood (I used Baltic birch). Start off by cutting all the plywood panels that make up the case to size. You'll need two sides (A), two shelves (B), a bottom (C), and one large panel for the back (D).

The sides will be joined to the shelves and back of the case with dadoes and grooves. But to avoid cutting a dado in the wrong place, I labeled the inside face of each side (left and right). Then I cut away the corner at the top of each side, as shown in Figure 2.

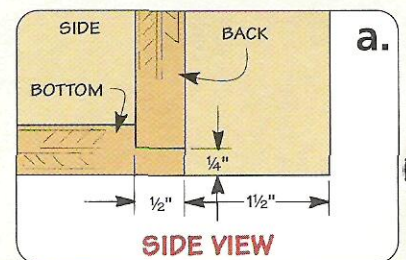
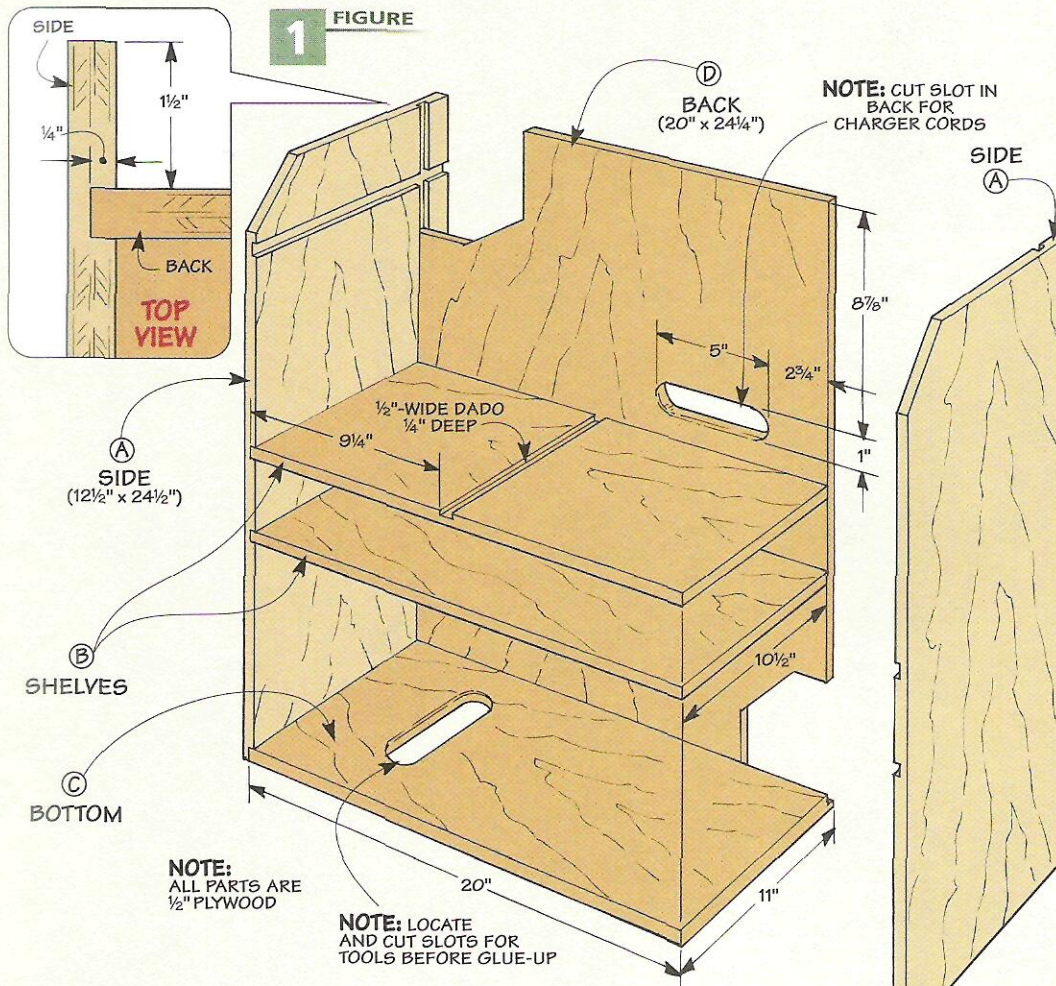

To cut all the dados and grooves in the sides, I used a dado blade. The trick here is to set up your dado blade to match the thickness of the plywood you're using. I made a few test cuts in some scrap pieces to get the width just right. This way the shelves will slip into place perfectly when it comes time for assembly.

Once the dado blade is in place on your saw, you can start cutting the joints. A groove is cut near the back edge of each side for the back panel (Figure 3a). Then the dados and rabbets are cut for the shelves and bottom, as shown in Figures 3 and 3b. There are a couple of points to be aware of when cutting these joints. First, keep in mind that there will be a left side and a right side, so make sure you are cutting the joints on the inside face of each side panel.

Second, if you look at Figure 2, you'll notice that the left side has an extra dado near the top. This is to hold the drill rack that will be added later. Make sure you cut this extra dado only on the left side panel — not on the right side panel.

Shelves – The only joint you'll need to cut in the shelves is a single dado in the top shelf. This will hold the drill support. You can use the same dado setup you used when cutting the joints on the sides.

Openings – There's one thing left to do before assembling the case and that is to cut a couple of narrow

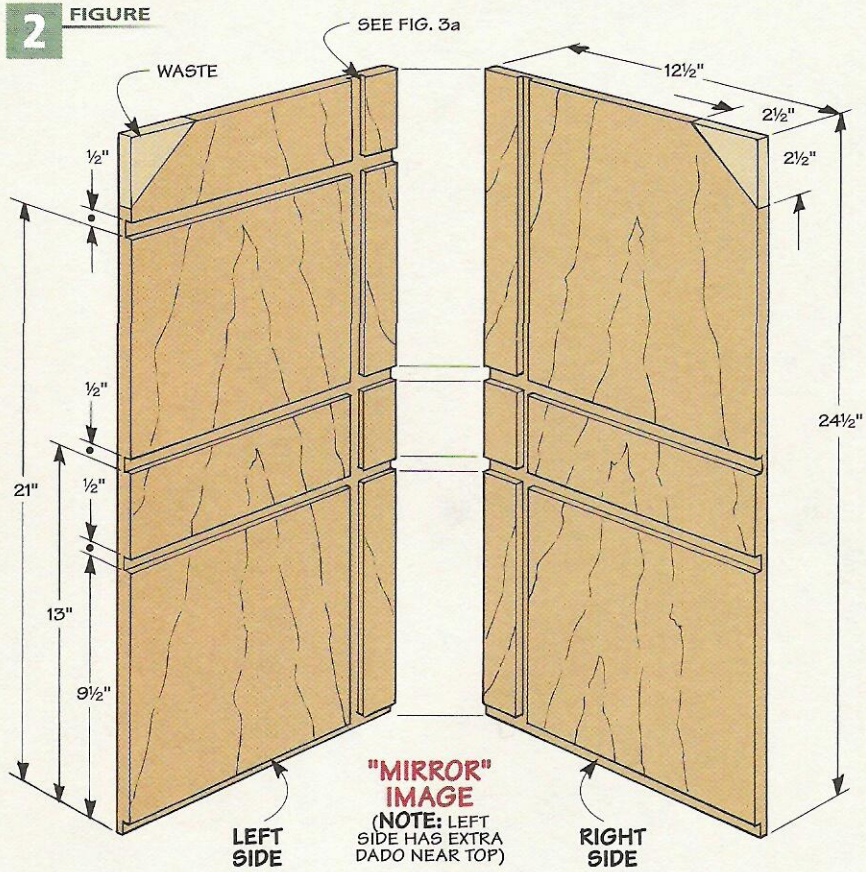

openings in the back and bottom. The opening in the back is for the cords for the battery chargers. And the opening in the bottom is to allow you to store your trim saw. (This opening can be altered or omitted to fit the tools you own.)

To make these openings, I simply laid them out and then drilled a hole at each end. A sabre saw can then be

used to remove the waste in between the two holes. After a little sanding to smooth the edges, you're ready to assemble the case.

Assembly – Assembling the case is just a matter of gluing and clamping all the parts together. Once you have the clamps in place, measure diagonally across the corners to make sure the case is square.

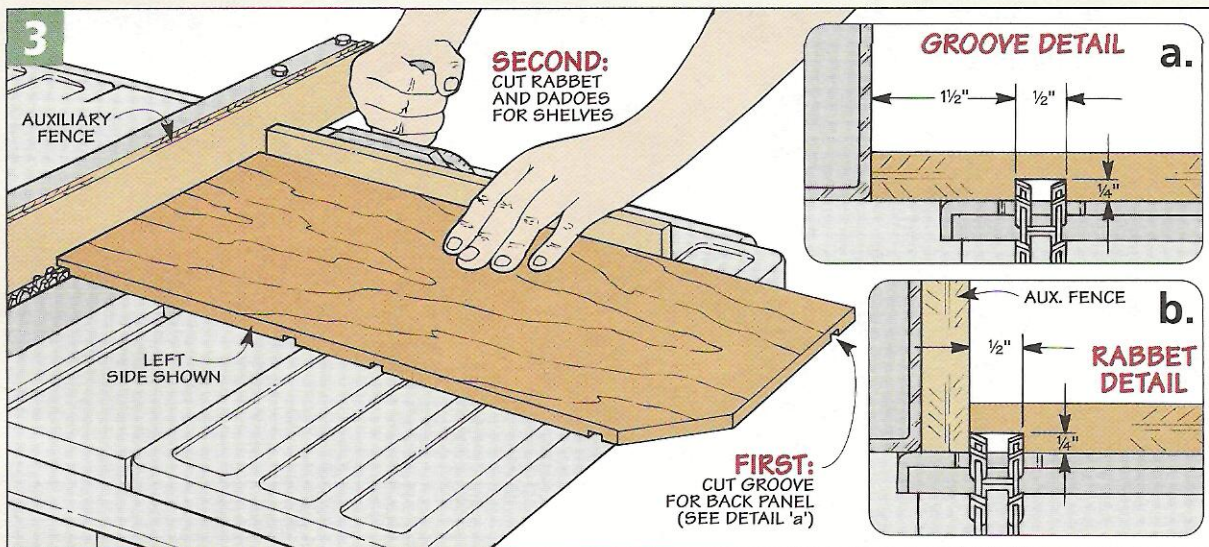

Drill Rack



With the main case completed, all that remains is to make a couple of add-ons for the cabinet. The first of these is a rack to hold cordless drills. This rack is made up of two pieces — a plywood *support* (E) and a small *platform* (F). The platform serves as a “holster” for the drills, cradling them in a couple of slots.

As you can see in Figure 4, both of these pieces are cut from 1/2" plywood. The support is simply rabbeted along the top to hold the platform (Figure 4a). But the platform requires a little more work. After it's

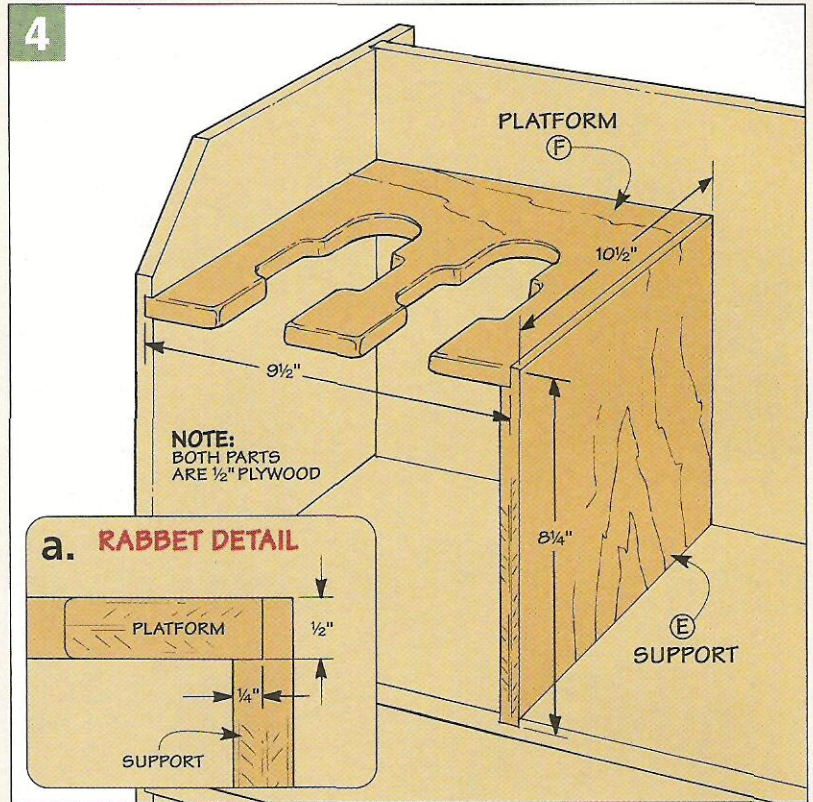

cut to size, you'll need to create the slots that hold the drills.

Slots – I ran into a little bit of a snag when it came to making these slots. At first, I thought a simple narrow slot would work just fine for holding a drill. But I discovered that on some cordless drills, the reversing switch is

located right where the drill rests on the platform, causing the switch to be pushed out of position.

To solve this problem, I just made the slots wider in the middle to accommodate the reversing switch. To do this, I drilled a series of holes to locate the outlines of the slots, as shown in the diagram at left. Then I cut away the waste in between the holes with a sabre saw.

After the waste is removed from the slots, the edges can be sanded smooth. A good way to get into the curves inside the slots is to wrap some sandpaper around a dowel that matches the radius of the curve.

To soften the edges of the slots and prevent them from splintering and chipping, I rounded over the top and bottom edges of the openings (as well as the front edge of the platform). Then the platform and upright can be glued and clamped in place. The dadoes in the side of the case and the upper shelf should help hold the pieces in place while you clamp them up.

PLATFORM CUTTING DIAGRAM

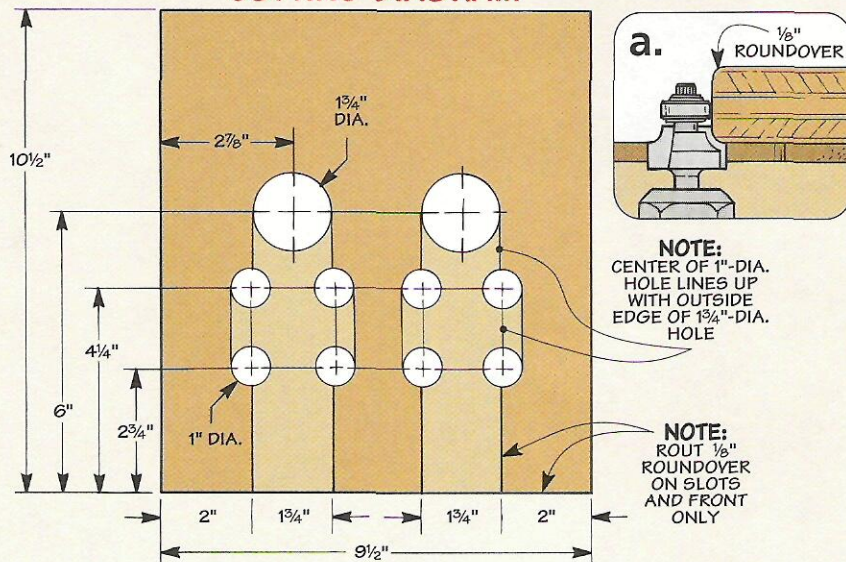

Drawer

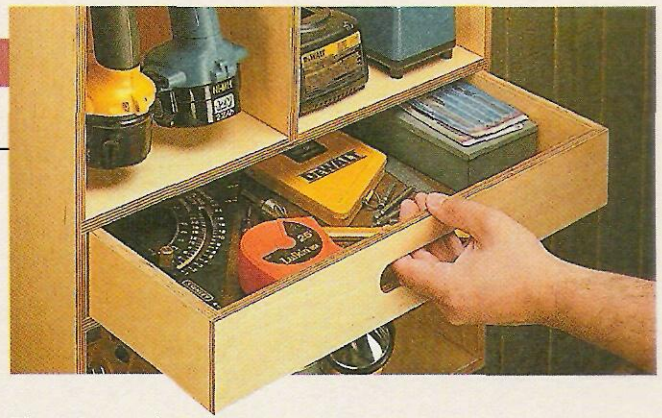

The center section of the shelf contains a shallow drawer for holding small items like drill bits, blades, wrenches, or chuck keys. The drawer is constructed from 1/2" plywood with a 1/4" hardboard bottom. It's sized to fit in the opening with a slight (1/16") gap at the sides and top.

To make the drawer, start by cutting two *drawer front/back pieces* (G) and two *drawer sides* (H) from 1/2" plywood. The dimensions for these pieces can be found in Figure 5. After cutting the pieces to size, the ends of the drawer front and back

are rabbeted to hold the drawer sides, just as you see in Figure 5a.

Once the rabbets are cut, a groove can be cut or routed on the inside face of each drawer piece, near the bottom edge (Figure 5b). This groove will hold the drawer bottom.

Hand Opening – The front of the drawer has an oval-shaped opening that serves as a hand-hold. This opening is centered on the width and height of the drawer front. To make the opening, I just drilled a couple of 1"-dia. holes and cut away the waste in between.

Then I rounded over the edges of the opening on both sides.

Drawer Bottom – The last step is to add a bottom to the drawer. This *drawer bottom* (I) is just a piece of 1/4" hardboard. Once it is cut to size, the drawer can be assembled with glue.

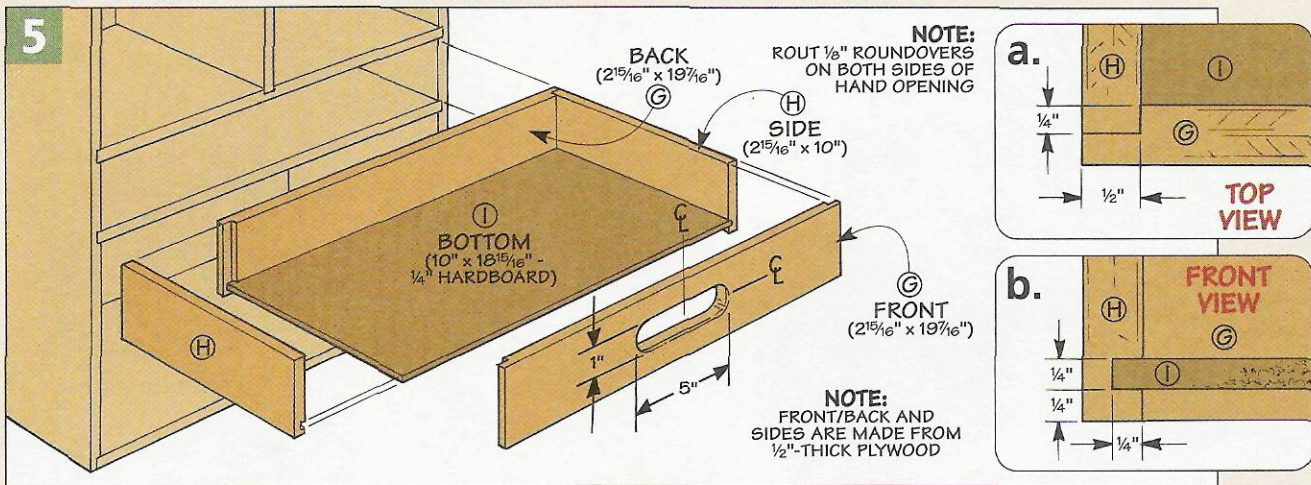

Wall Mount

After applying a finish, the storage cabinet is complete. All that remains is to hang it on the wall. I used a couple of interlocking cleats to do this. A 45° bevel is ripped along one edge of each cleat. Then one of the cleats is glued to the back of the cabinet while the other is screwed to the wall. (Make sure you screw the wall cleat to studs to provide plenty of support for the cabinet.)

Once the wall cleat is mounted, all you have to do is set the cabinet on the cleat. Then you can place your cordless tools and battery chargers on the shelves. The space behind the back of the cabinet provides a "raceway" for the power cords, see Figure 6a.

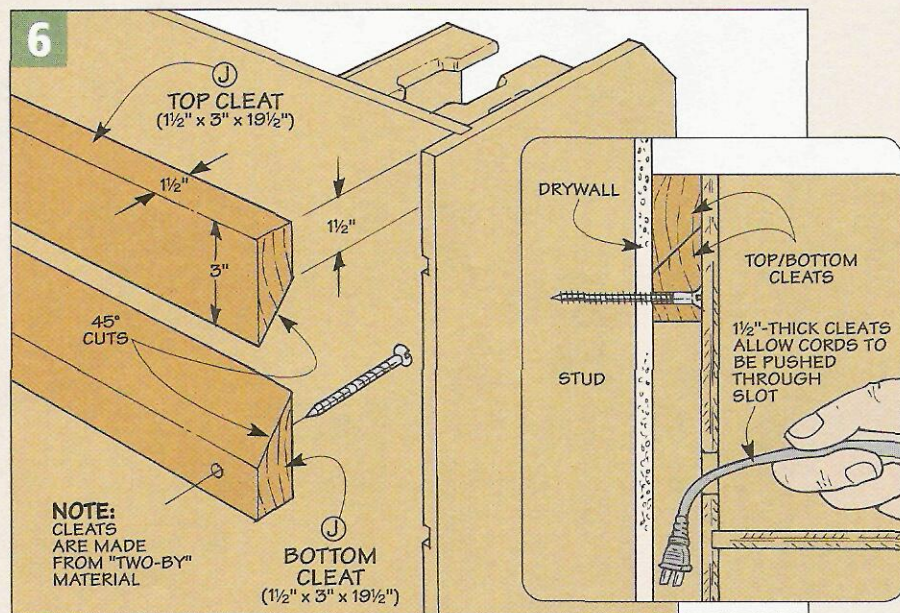

Working with Polyurethane Glue

Put it down, “water” it, and watch it grow. Here’s the lowdown on polyurethane glue.

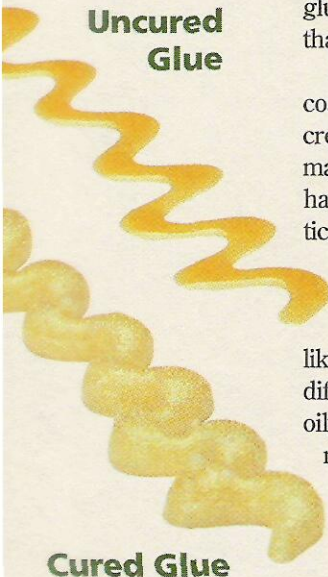

I know. It sounds more like a finish than a glue. And the truth of the matter is polyurethane (or “poly”) glue shares the same type of resins that make up polyurethane finish.

But instead of forming a finish coat, the resins join together to create an adhesive film between the materials you’re bonding. Poly glue has a number of great characteristics. It’s easy to sand and clean up and it’s resistant to solvents and water. And like epoxy, poly glue will bond dissimilar materials like metal and wood, or wood that’s difficult to work with like exotic or oily woods. But instead of having to mix two ingredients, poly glue is a one-part liquid that you use straight from the bottle.

Foaming – The one thing that takes some getting used to is what happens after you apply the glue. As you can see in the margin photos, poly glue doesn’t look much different from most other glues right

out of the bottle (top photo). It’s when it begins to cure that it acts a little differently.

As it cures, it releases carbon dioxide. This causes the glue to expand, making the glue look like the foam insulation you spray out of a can.

Now don’t let the looks fool you. Even though the foam will fill any gaps in your joint, the bubbly foam has very little strength.

So it’s not a good idea to count on poly glue to make up for a poor-fitting joint. As always, for the glue to form a solid, strong bond, you need to have a tight-fitting joint.

Application – To avoid a lot of excess foam-out, it’s best to apply a small amount of glue to the workpiece. I typically use about one-third to one-half the amount I would use if I were using yellow glue (Step 1). And I generally apply it to only one side of the joint. As a matter of fact, if it feels like you’re not using enough, the amount is probably just about right.

Spread to a Film – Like most other glues, once you’ve applied a thin bead of poly glue it’s a good idea to spread it across the workpiece. The flexible plastic spreader shown in Step 2 makes quick work of this. (A piece of plastic laminate works just as well.)

Add Moisture – With the glue spread to a thin layer, you’re almost ready to start assembling things. But there’s one thing you’ll need to keep in mind. And that’s the moisture content of the wood you’re using.

Polyurethane glue requires moisture in the wood (and surrounding air) to cure properly. (The glue works best when the moisture content of the wood is 8% to 20%).

So when I’m using hardwoods which typically have a low moisture content (or when I’m working in the dry air of winter), I make sure there’s enough moisture by misting the mating workpiece (Step 3). You don’t need to flood the workpiece. A light spray is all that’s necessary.

▲ When it’s first applied (top photo), polyurethane glue looks like most glues. But as it cures, it expands like foam insulation from a can.

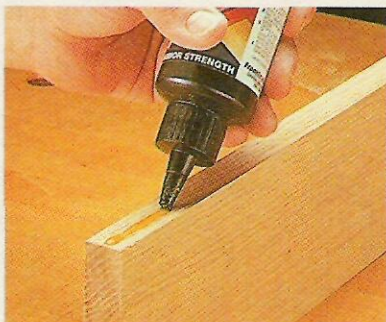

1 Apply Bead. To avoid excess squeeze-out and foaming, apply a thin bead of glue along one edge.



2 Spread. Use a flexible piece of plastic or laminate to spread the glue evenly along the edge.



3 Mist. To provide the moisture to cure the glue, lightly mist the edge of the mating workpiece.

But if you're building an outdoor project from something like cedar or pressure-treated lumber, you can skip the misting altogether. These materials typically have a higher moisture content. So you don't need to add anything extra.

Assembly Time – At this point, you can assemble the project. And this is where polyurethane glue really shines — you don't have to work as fast as the pit crew at an Indy race. Poly glue provides more working time when it comes to assembling and positioning the parts of a project before you clamp it up.

A yellow glue can set up after only a few minutes. I've actually had the parts of a project "seize" before I could get everything assembled and then positioned correctly.

That's not likely to happen when you use a polyurethane glue. Most poly glues have working times ranging from 20 to 30 minutes. So when you have to assemble a complex project, a poly glue provides more time to get everything right where it needs to be.

Clamping – When it comes to clamping, using poly glue isn't a whole lot different than other glues. Moderate clamping pressure is all that's required. As long as the pressure spreads the glue into a thin layer, you'll end up with a strong, consistent bond.

The thing to remember is that you'll need to leave the assembly clamped up for several hours. So don't get in too big a hurry to pull the clamps off your assembly.

Cleanup – Once the glue has set, the next step is to get the dried glue off. Unlike yellow glue which can be a problem to remove, poly glue breaks down into a fine dust when you sand it. Or you can simply scrape it away or pop it off with a chisel, as shown in Step 4.

As you can see, dealing with cured poly glue on a project isn't a problem. It's a different story if the glue dries on your hands — as I learned the hard way.

I didn't give much thought to cleaning up the first time I used poly glue. Once I was done working, I tried to scrub the glue off with a little soap and water — without success.

The glue stained my hands and fingers a dark brown. And it was a few days before it started to wear off.

To avoid this problem, I find it best to slip on a pair of disposable gloves as soon as I pull the bottle of poly glue from the cabinet. Then whether I'm assembling a project or cleaning up afterwards, it's a simple matter to toss the gloves in the trash once I'm done.

Safety Note: Some people can be sensitive to polyurethane glue. So besides wearing gloves, it's also a good idea to work in a well-ventilated area or even wear a respirator.

Even though it's almost impossible to clean poly glue off your hands, removing any excess from your tools or workbench is a lot easier. All it takes is a paper towel or cloth soaked in a little acetone or mineral spirits, as shown in the margin photo. (And don't forget the gloves.)

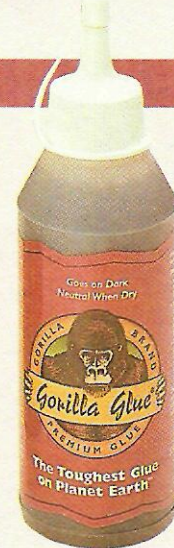

▲ Polyurethane glue that's stored upright (right) will cure at the top of the container, unlike the "upside-down" bottle shown at left.

Shelf Life & Storage – Another drawback of poly glue is its shelf life. I've kept yellow glue around for over a year and used it without any problem. But poly glues often have a shelf life much shorter than that.

As soon as you open the container, poly glue can start to cure. So it's a good idea to close the container any time you're not using it. And when you put it away, squeeze out any excess air (and moisture) first.

Some manufacturers have even designed their containers to store "upside down," as you can see in the photo above.

Cost – The thought of throwing out any glue because it's cured in the container is bad enough. But when you consider that polyurethane glue costs two to three times as much as yellow glue, the sticker shock just might make you think twice (or three times) about buying some.

But as I mentioned before, you're only using about one-third as much (and generally, only applying it to one side of the joint). So the actual costs of using it are fairly comparable.

Use It or Lose It? – Despite some of its drawbacks, polyurethane glue has a lot more going for it. That doesn't mean I'm going to replace the yellow glue I've used in the past. But it will have to share some of the shelf space in my cabinet with a small bottle of polyurethane glue. 🐼

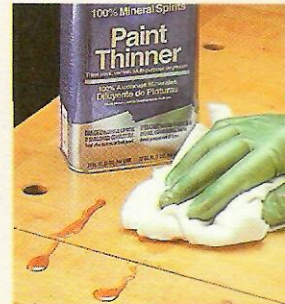

▲ Cleaning up uncured poly glue isn't a problem when you use a solvent like mineral spirits (and a pair of disposable gloves).

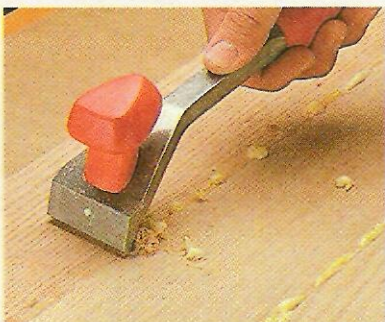

4 Remove Excess. Finally, remove the dried "foam" by scraping (shown above left) or sanding. Removing glue from hard-to-reach areas like a corner (photo at right) is a snap with a sharp chisel — it "pops" right off.

When it comes to setting up a woodworking shop, most of us have to make do with whatever space we can find that isn't already taken up by storage, vehicles, or living quarters. Whether they're in a basement or a garage, most shops are put together only after all the other needs of the household are met.

Daryl Sullivan went about things a bit differently. He took care of his shop first and then worried about the house. It all started a few years ago when Daryl and his wife decided to move out of town and build a house in the country. Before breaking ground on the house, Daryl had a separate building erected for a shop, complete with an apartment upstairs. The idea was that the couple would live in the apartment while the house was being built. And in the meantime, Daryl could use the shop to make all the trim and cabinets for the house.

Today, both the shop and the house are finished, and Daryl's woodwork is evident throughout the house, as you can see in the photos below. But the shop doesn't sit idle by any means. Daryl spends just about every minute of his free time

Have you ever dreamed about having more shop space? Take a look inside this shop.

Home Furnishings Built in a Country Shop



there, turning out furniture projects for family, friends, and even a few paying customers.

Recently, I had the opportunity to visit Daryl and his shop. Daryl's shop is located in eastern Iowa, amid rolling farmland. The first thing that impressed me as I drove up was its appearance. From the outside, it

looked more like a guest house than a shop (see photo above). And at roughly 1900 square feet, it's bigger than many houses. But once you're on the inside, there's no mistaking the fact that you're in a woodworking shop.

Even though the shop is huge by most standards, it still has a warm,



▲ **Entertainment Center.** Working in his shop next door, Daryl built this large combination entertainment center and curio cabinet for the great room of his new house.

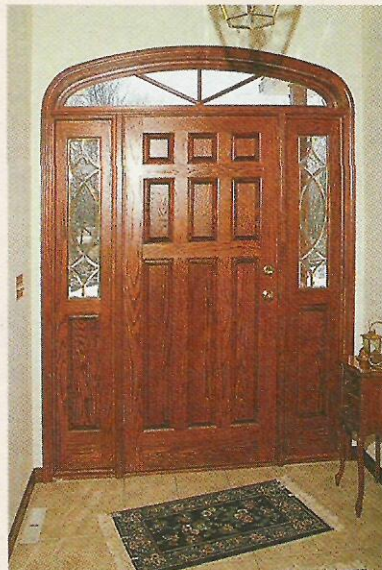

▲ **A Grand Entrance.** The raised-panel entry door and side lights were also made by Daryl.



▲ **Custom Cabinets.** Daryl's craftsmanship can also be seen in these fine kitchen cabinets.

SHOP PROFILE

inviting feel. Part of this is probably due to the knotty pine paneling. But if you take a look at the floor plan drawing at the right, you'll see that it also has to do with the fact that the shop is divided up into several separate areas. This way, you don't feel like you're walking into an airplane hangar when you enter.

Layout - The building is essentially divided into four distinct areas. These include a tool room, an office, a lumber storage area, and a finishing room.

The main area of the shop is where the power tools are housed. This is a large, open room. A steel I-beam helps to support the roof and ceiling so that there aren't any columns to get in the way of the shop floor space. There are several windows to let in lots of natural light. And a bank of cabinets lines the back wall providing storage for small tools and hardware.

As in most shops, the table saw is located in the center of things. Most of the other tools line the walls around the shop. When he was building the shop, Daryl installed a 4-plex outlet every 32" along each wall so he didn't have to worry about where he located machinery.

A system of overhead ducts carries sawdust away to a dust collector that is enclosed in a small utility room just off the main room of the shop. Having the dust collector isolated helps keep the noise down when it's running.

Conveniently, he has a hose running to each major power tool, but the dust collection system is the one thing that Daryl wishes he had done differently. "If I was starting over, I'd put the ducts in a channel in the floor, with a removable cover over them for access."

At the back of the main shop area, off to one side, is a small room that serves as an office. Here, Daryl has a desk and shelves full of woodworking magazines and plans, along with some larger items that don't fit in the cabinets in the shop. In addition to this office,

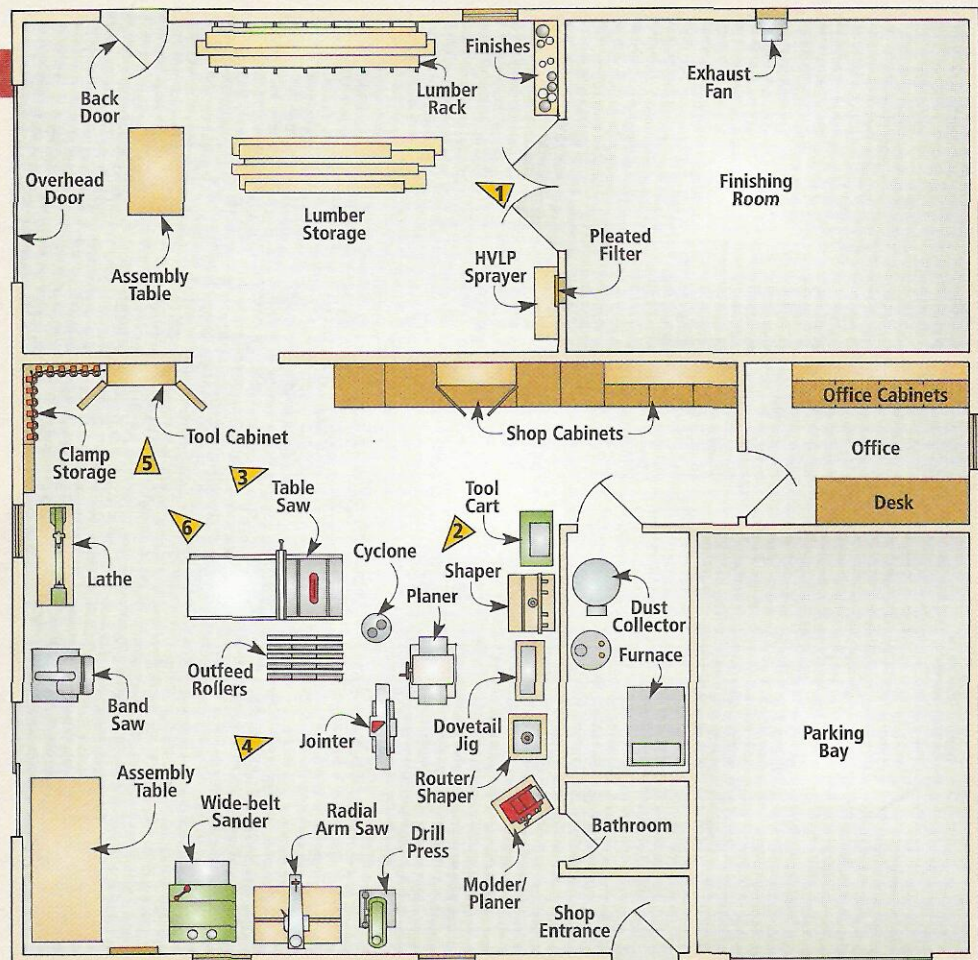

Shop Layout Plan

▲ = View Angle

there's also a bathroom off the main shop area.

Originally, this was the extent of Daryl's shop. But last summer, he put an addition on the back of the

building. The addition contains a lumber storage room and a dedicated finishing room.

Lumber Storage - As you can see in the photo at left, lumber is stored on a welded steel rack that is bolted securely to the wall. But what's really nice about the lumber room in Daryl's shop is that it has an overhead garage door at one end. So all he has to do is back his truck in and unload the lumber onto the rack. The overhead door also makes it convenient to move projects out once they are completed.

Finishing Room - At the other end of the lumber storage room is a door leading to the finishing room. This is simply an empty, well-lit room, large enough to handle just about any size project.

Daryl sprays most of his finishes using an HVL (high-volume, low pressure) sprayer. An explosion-proof fan is mounted on one of the exterior walls of the finishing room to exhaust the fumes and overspray outside.

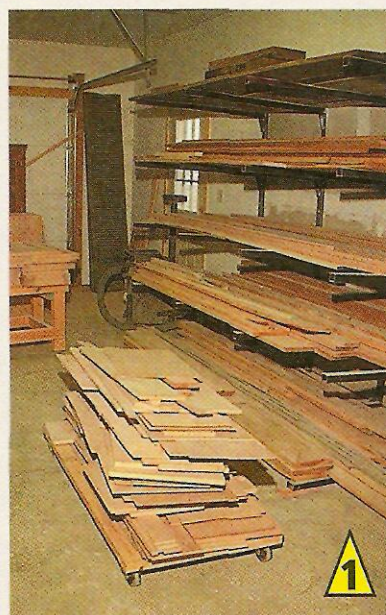

▲ **Lumber Storage.** A heavy-duty, welded steel rack holds Daryl's supply of hardwood lumber.

Equipment

When it comes to shop equipment, Daryl has no trouble filling up the space of his spacious shop. He has just about every major tool you would expect to see in a well-equipped shop, including a couple that I imagine some professional shopowners might drool over. You can see most of these in the photos on this page. One of these is a molder, which is capable of spitting out endless runs of crown molding as smooth as glass. (Daryl fired it up while I was there and gave me a demonstration.)

Daryl noticed me admiring the table saw in the middle of the shop, along with its after-market, over-arm blade guard. He told me that the blade guard was added after an unfortunate kickback experience that occurred while working late one night. Although he admits that it's a little like closing the barn door after the horse has run out, the guard serves as a constant reminder that you can never be too careful.

Although his shop is well-equipped today, it wasn't always this way. Daryl assembled his collection of machinery one piece at

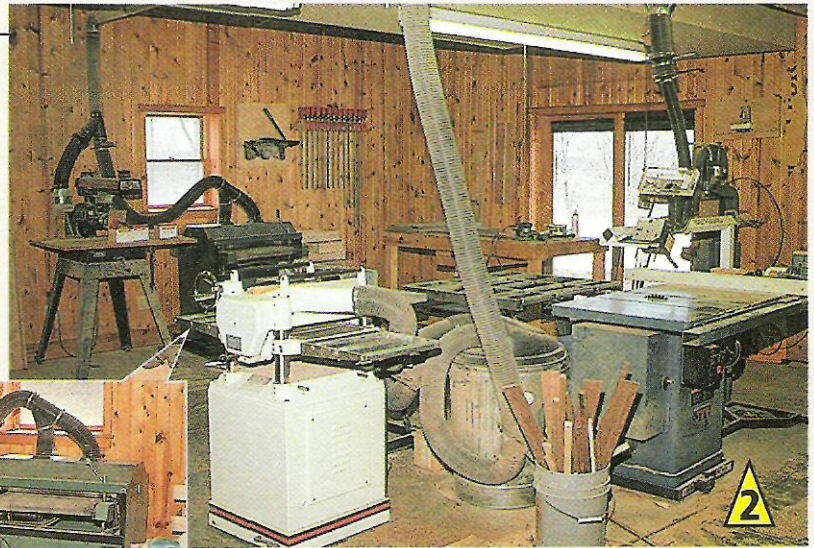

▲ **Shop Equipment.** A wide belt sander, a 15" planer, and a cabinet saw are some of the big power tools that Daryl uses regularly in his shop.



a time, trying to keep his craving for new tools in line with his spending budget.

Hand Tools – Most of the small hand tools that Daryl uses are stored in a wall-mounted cabinet. (You can see this cabinet in the photos on the opposite page.) And right next to this tool cabinet is a clamp storage area. Pipe clamps, C-clamps, and bar clamps are lined up in neat rows along the wall. Several

storage racks hold the clamps, see box on opposite page.

One thing that struck me as I looked around the shop was the absence of a woodworking bench. Aside from the cabinets along the back wall of the shop, the only other work surface was a large assembly bench where Daryl does most of his sanding and gluing up of projects. But there wasn't a vise of any kind

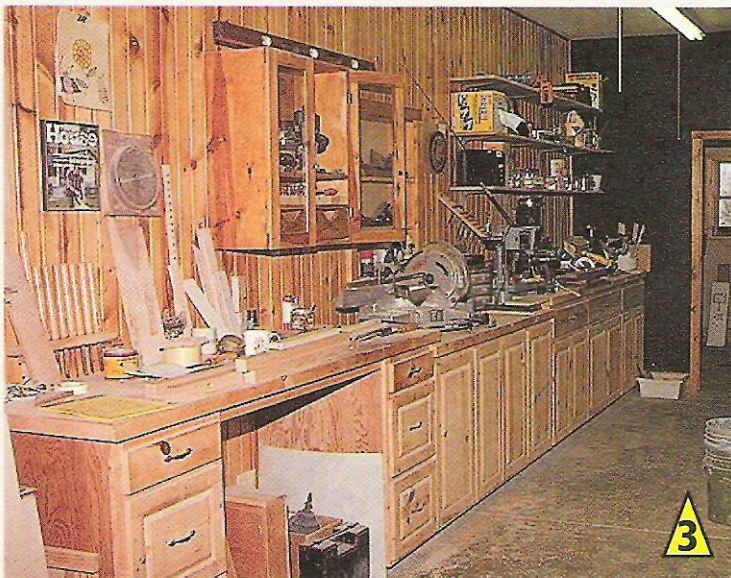

▲ **Shop Cabinets.** A long bank of shop cabinets provides plenty of storage for hardware and tools. A miter saw station is built into the long work surface above the cabinets.

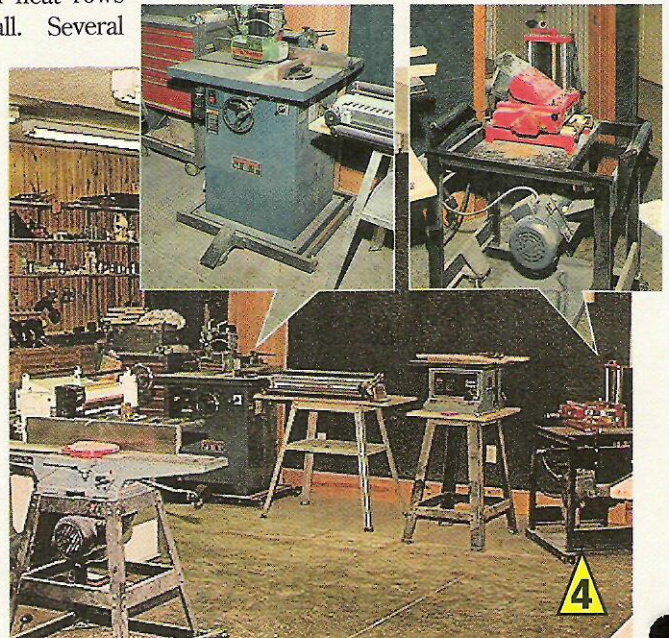

▲ **Stationary Tools.** Daryl's stationary tools line the walls of the shop. Even with all the space available, many of the tools are on mobile bases for convenience.

Shop Tours ON THE WEB

Want to see more woodworkers' shops?

Or have your own shop featured in ShopNotes?

Visit us on the Web at ShopNotes.com

on the bench (or anywhere else in the shop, for that matter).

When I pointed this out, Daryl nodded and admitted that he still needed a good bench. I guess it just goes to show that no matter how many tools you have, there's always room for at least *one* more item to be added to the list.

Climate Control - Of course, having plenty of room doesn't do you much good if the shop is too cold (or hot) to work in comfort. And in Iowa, that's the case about ten months out of the year. Daryl wanted to be able to use his shop year round. So he installed an electric heat pump to keep it warm in the winter, and air conditioning to keep it cool in the summer. Even in the dead of winter, the temperature inside the shop never gets much below 65°.

With the recent spike in energy prices, I wondered how much it cost to heat a shop of this size. I was surprised to learn that the most Daryl paid for utilities in a single month last winter was \$120. The answer lies in the building's construction. Daryl designed the shop building to be energy-effi-

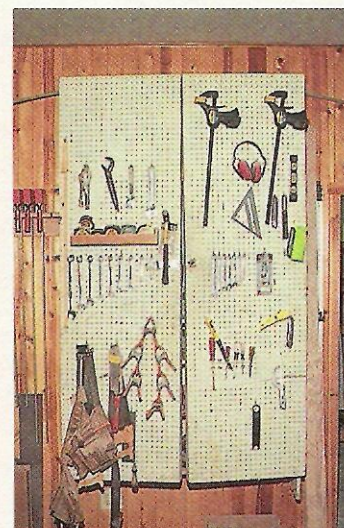
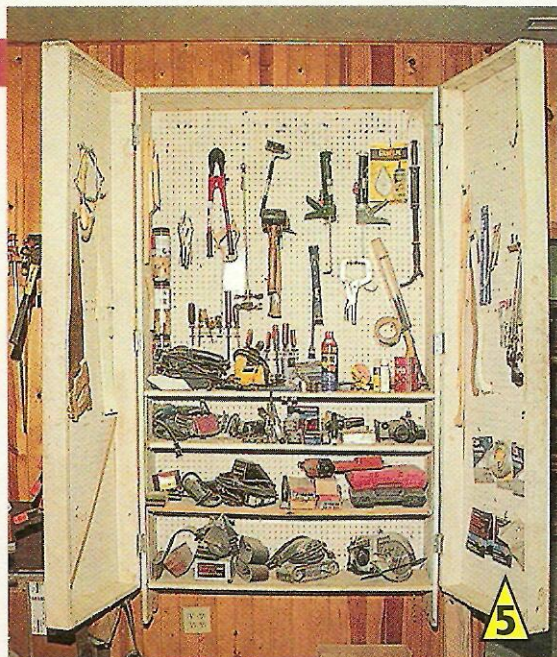

Hand Tool Storage. A wall-mounted storage cabinet provides easy access to commonly-used hand tools.

cient. The walls are made of concrete-filled foam blocks that are a foot thick. These act as thermal insulation, helping to conserve heat during the winter and cooler air during the summer.

Aside from making for a much more pleasant working environment, controlling the temperature and the humidity has other benefits. Daryl says he doesn't have to be as concerned with wood movement in the shop or with rust forming on the cast iron surfaces of his tools.

Conclusion - It's easy to get a little overwhelmed when looking at all the space Daryl has for his shop as well as all the equipment that it's filled with. But having a huge, well-equipped shop doesn't automatically make you a better woodworker. More important than the size of your shop or the number of tools you own is how well you use them. That's something worth keeping in mind, especially if (like most of us) you're working in a modest shop with basic tools. 🛠️

Clamp Storage System Ideas

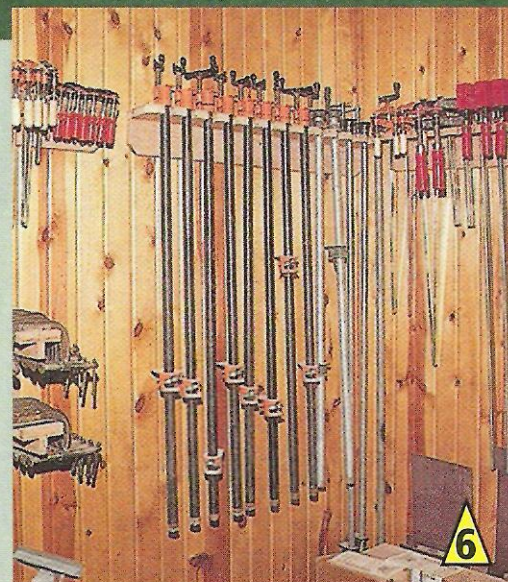
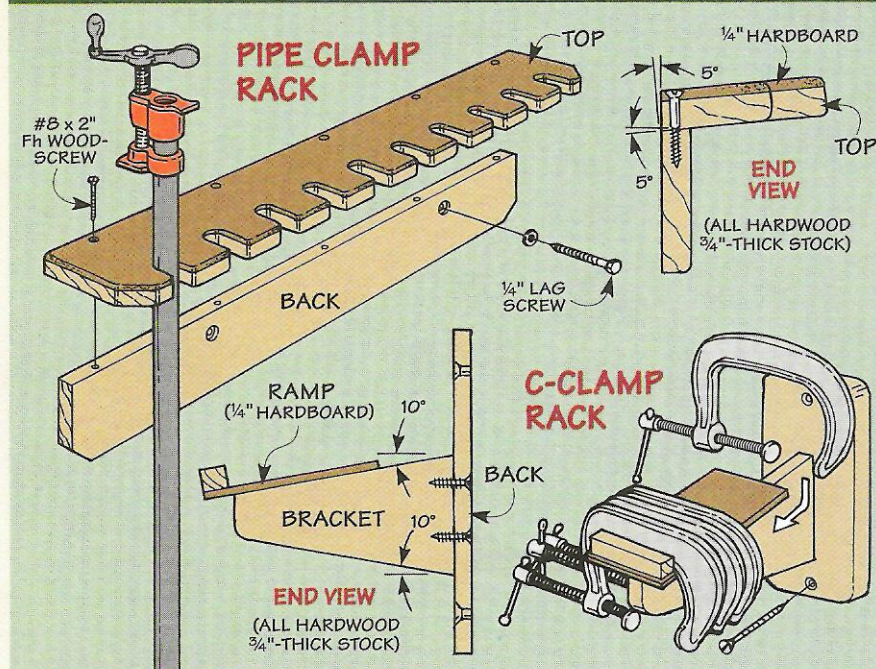

Clamp Storage Wall. Several storage racks keep all the clamps lined up in neat, orderly rows, ready to go at a moment's notice.

Miter Saw Station

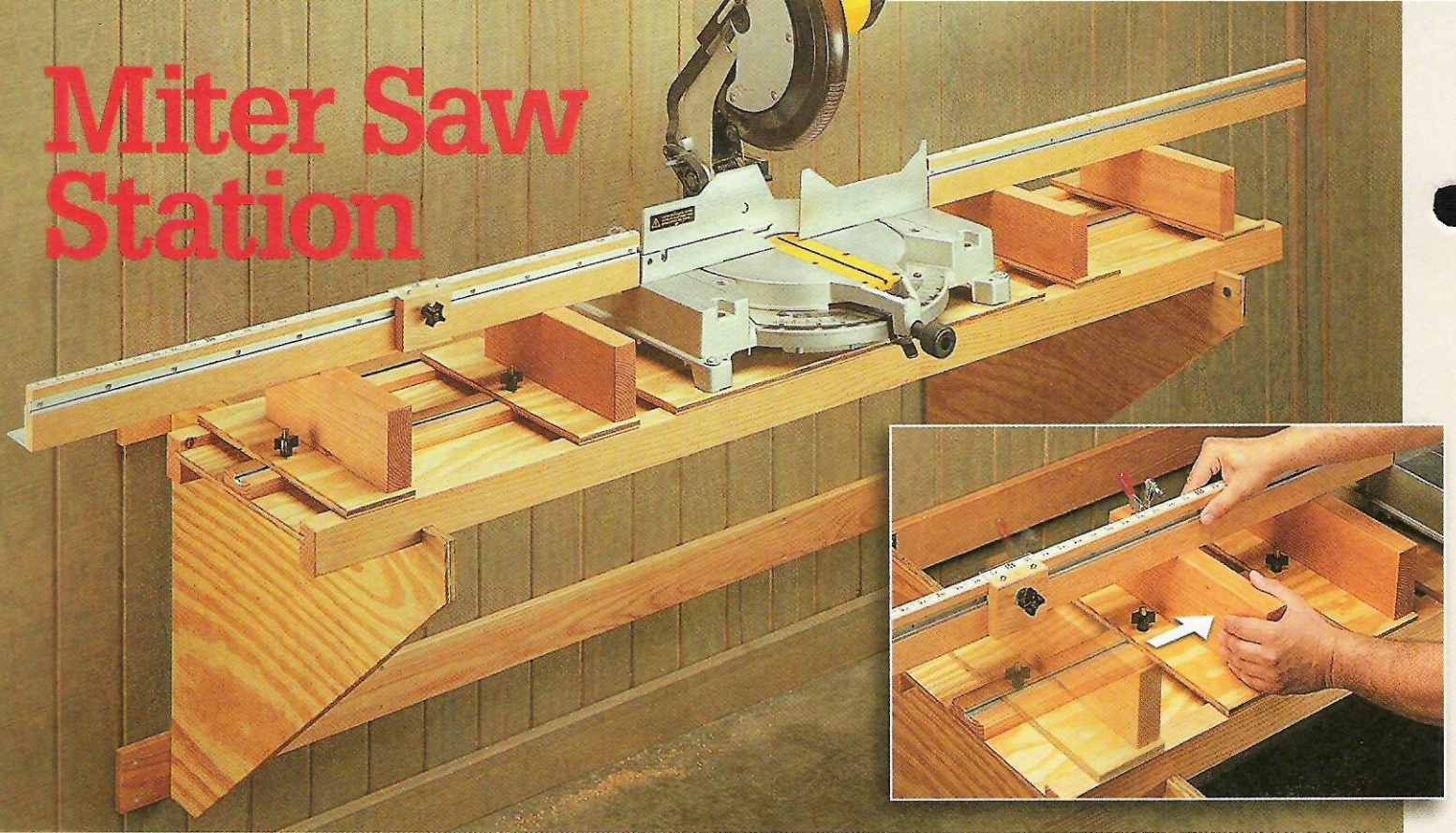

Portable, sturdy, adjustable, and accurate. This miter saw station has it all.

Miter saws are showing up in a lot of woodworking shops — and outside the shop as well. And that's the main reason for the miter saw station shown above. It's packed with features that make it a great project — whether you're in the shop or on the job site.

Portable — The station is designed to be portable. In the shop it can rest on a bench or on a fold-out, wall-mounted bracket (photo above). And when you need to move outside the shop, just lift the station off the bracket and use a pair of sawhorses for support (photo below).

Adjustable — But there's something I like even more about this project — its adjustability. Instead of having

the fence and miter saw in a fixed position, they're mounted to platforms that *slide* along the base (see inset photo above). So when you need more support on one side of the saw than the other, just loosen the platforms, slide them where you need them, and lock them in place.

Accurate — But this versatility doesn't come at the expense of accuracy. An adjustable stop that slides in an aluminum T-track makes it extremely accurate. Along with a tape measure and hairline indicator, you can set precise, repeatable measurements.

Storage — Now you might think this station will take up a lot of space when you aren't using it. But it's a real space-saver. To store the station, just remove the miter saw, slide the fences together, and hang the base (with the fences) on a cleat mounted to the wall (refer to page 23).



▲ **Portable.** A lightweight design and carrying handles make the miter saw station easy to move to the job site.

EXPLODED VIEW
OVERALL DIMENSIONS:
 94 1/4" W x 33" D x 47" H
 (w/ MITER SAW SHOWN)

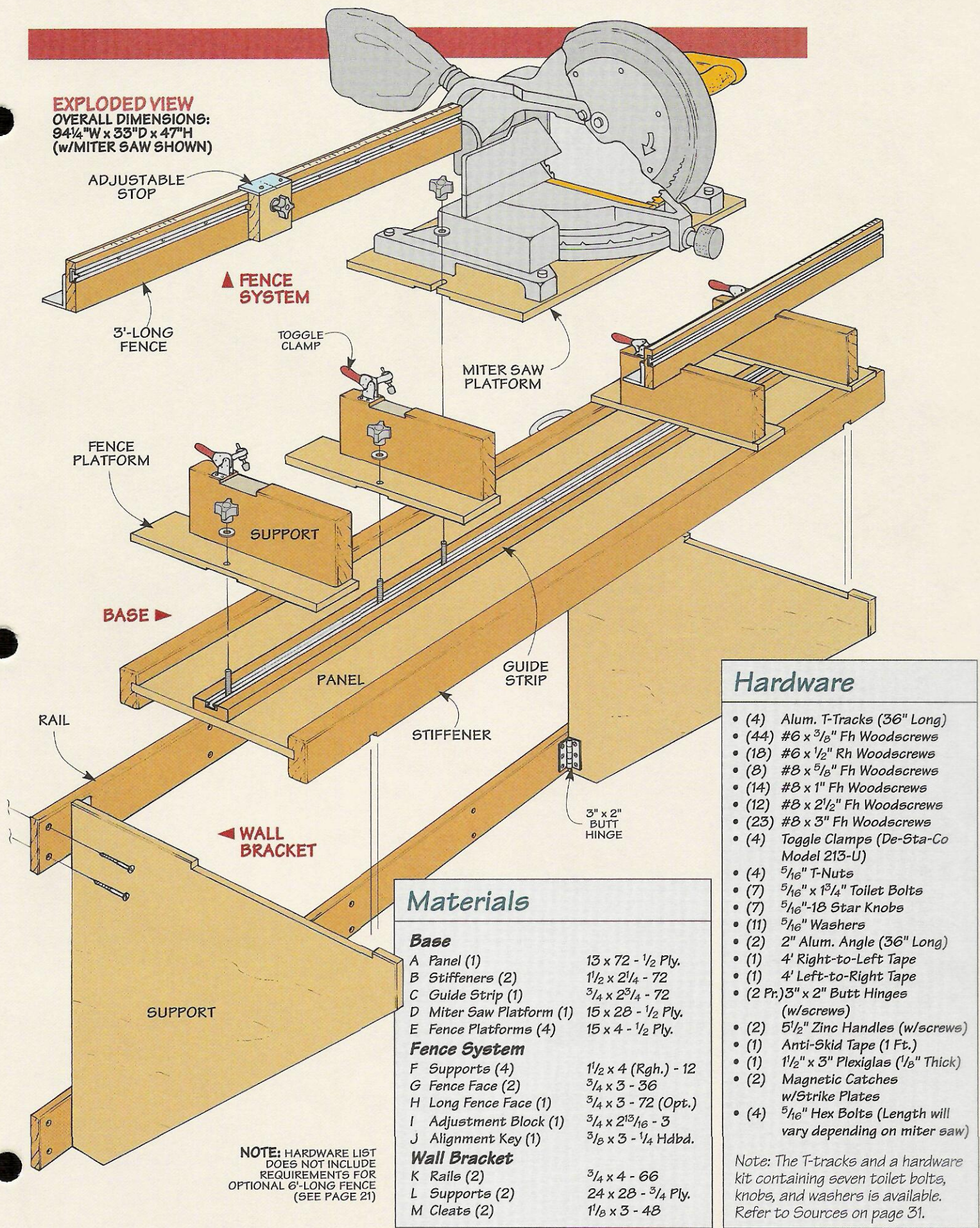

FENCE SYSTEM

BASE

WALL BRACKET

Hardware

- (4) Alum. T-Tracks (36" Long)
- (44) #6 x 3/8" Fh Woodscrews
- (18) #6 x 1/2" Rh Woodscrews
- (8) #8 x 5/8" Fh Woodscrews
- (14) #8 x 1" Fh Woodscrews
- (12) #8 x 2 1/2" Fh Woodscrews
- (23) #8 x 3" Fh Woodscrews
- (4) Toggle Clamps (De-Sta-Co Model 213-U)
- (4) 5/16" T-Nuts
- (7) 5/16" x 1 3/4" Toilet Bolts
- (7) 5/16"-18 Star Knobs
- (11) 5/16" Washers
- (2) 2" Alum. Angle (36" Long)
- (1) 4' Right-to-Left Tape
- (1) 4' Left-to-Right Tape
- (2 Pr.) 3" x 2" Butt Hinges (w/screws)
- (2) 5/16" Zinc Handles (w/screws)
- (1) Anti-Skid Tape (1 Ft.)
- (1) 1/2" x 3" Plexiglas (1/8" Thick)
- (2) Magnetic Catches w/Strike Plates
- (4) 5/16" Hex Bolts (Length will vary depending on miter saw)

Materials

Base	
A Panel (1)	13 x 72 - 1/2 Ply.
B Stiffeners (2)	1 1/2 x 2 1/4 - 72
C Guide Strip (1)	3/4 x 2 3/4 - 72
D Miter Saw Platform (1)	15 x 28 - 1/2 Ply.
E Fence Platforms (4)	15 x 4 - 1/2 Ply.
Fence System	
F Supports (4)	1 1/2 x 4 (Rgh.) - 12
G Fence Face (2)	3/4 x 3 - 36
H Long Fence Face (1)	3/4 x 3 - 72 (Opt.)
I Adjustment Block (1)	3/4 x 2 3/16 - 3
J Alignment Key (1)	3/8 x 3 - 1/4 Hdbd.
Wall Bracket	
K Rails (2)	3/4 x 4 - 66
L Supports (2)	24 x 28 - 3/4 Ply.
M Cleats (2)	1 1/8 x 3 - 48

NOTE: HARDWARE LIST DOES NOT INCLUDE REQUIREMENTS FOR OPTIONAL 6'-LONG FENCE (SEE PAGE 21)

Note: The T-tracks and a hardware kit containing seven toilet bolts, knobs, and washers is available. Refer to Sources on page 31.

Base

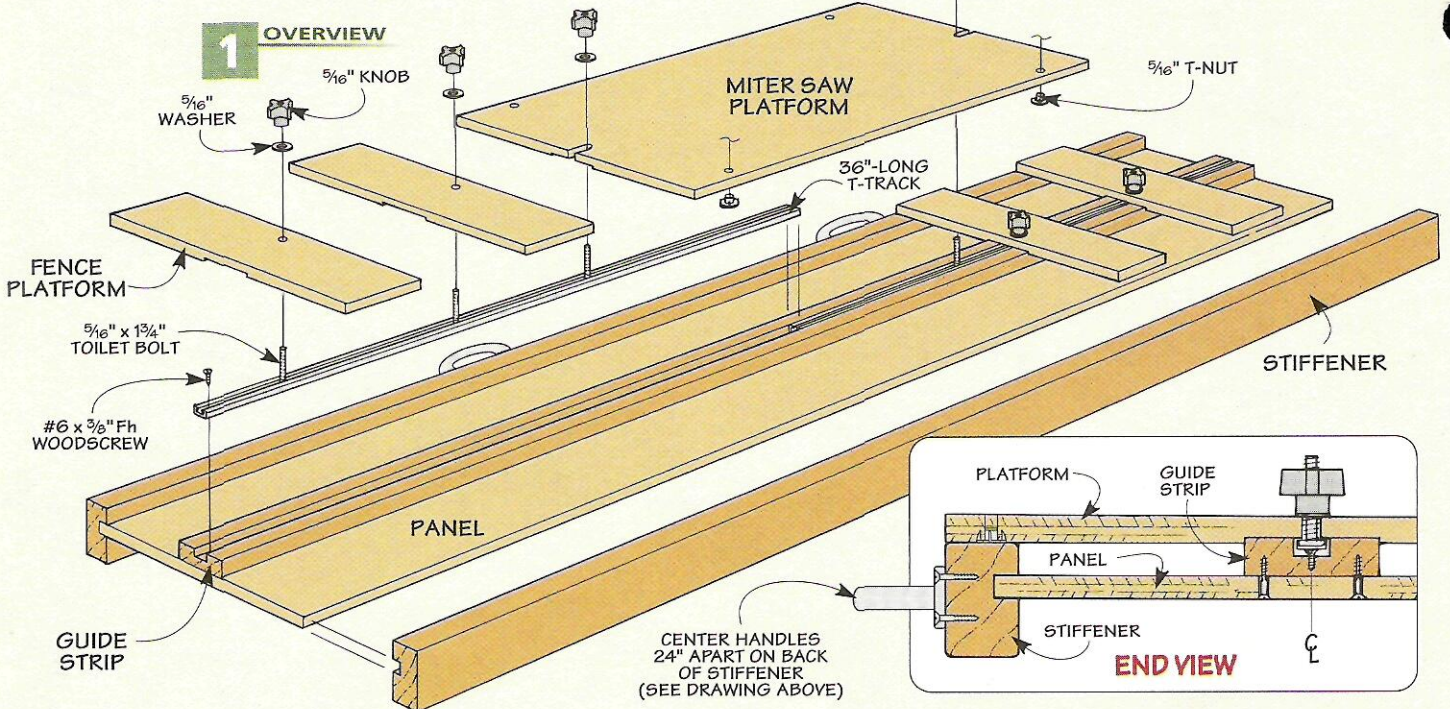

When designing the base of the miter saw station, there were a couple features I knew I wanted. First, it had to be lightweight so it would be easy to move around. But the base also needed to provide solid support for the miter saw, fences, and workpiece. So it had to be strong and rigid.

Base - To accomplish this, I made the base by connecting a pair of stiffeners with a plywood panel, as shown in Figure 1 above.

The *panel (A)* is nothing special. It's just a piece of 1/2" plywood (Figure 2). But when it came time to make the *stiffeners (B)*, I took a little extra time selecting a workpiece and didn't just grab a couple of ordinary 2x4s. Instead, I sorted through a stack of wider 2x stock to find a nice straight-grained workpiece. (I used Douglas fir.)

Assembly - Fitting the panel into the stiffeners is just a matter of cut-

ting a groove along the inside edge of each stiffener and then gluing the panel in place. This groove is positioned 5/8" down from the top edge of the stiffener (Figure 2b).

Guide Strip - At this point, the base will support the platforms (added later) for the miter saw and fence. But to keep them aligned as you move them around and lock them in place, I added a guide strip, as shown in Figure 2.

The *guide strip (C)* is just a piece of 1x stock that runs down the center of the base (see End View in Figure 1). To lock the platforms in place with knobs and toilet bolts, there's a pair of aluminum T-tracks installed in a groove cut down the center of the strip (Figure 2a). After installing the T-tracks, center the guide strip on the base and screw it in place.

PLATFORMS

With the base complete, you can turn your attention to the 1/2" plywood platforms shown in Figure 1 that rest on the base and will support the fences and miter saw. To keep the platforms aligned, there's a wide groove cut in the bottom of each platform that fits over the guide strip (Figure 1a).

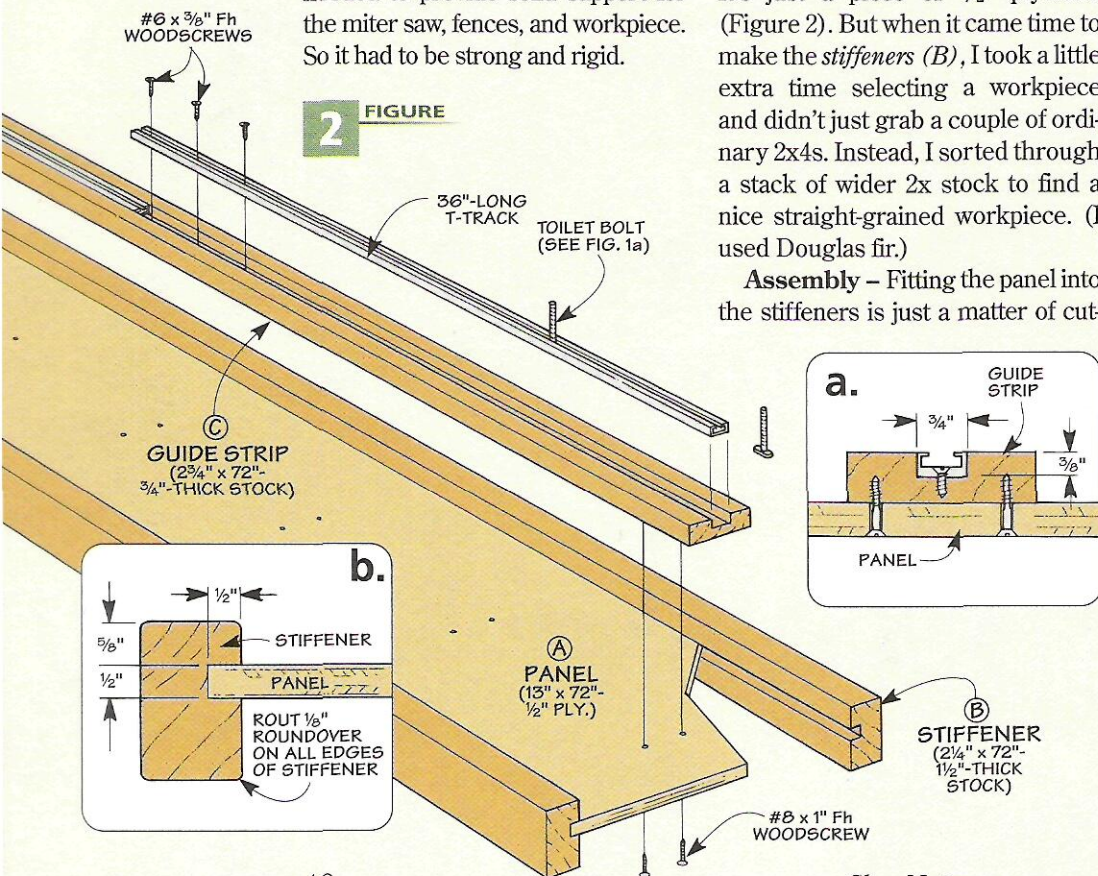

Of course, for this to work, the groove needs to be centered identically on each platform. The key to doing this is to cut the groove in all the parts at the same time.

The first thing to do is cut the miter saw platform (D) to final size (Figure 3). But make a large blank for the fence platforms (E).

Here's where I used a little trick to center the groove. First, position the rip fence so the blank is roughly centered over the blade (Figure 4a). Then after making one pass, flip the workpiece end for end and make a second pass (Figure 4b). Now you've got a perfectly centered groove.

To widen the groove, slide the fence closer to the blade and make two more passes, flipping the workpiece between passes. Continue this until the groove just fits over the strip.

Saw Platform - Now you're ready to complete the miter saw platform. Start by cutting a slot centered on each side of the platform (Figure 5a). The slot provides a way to lock the platform to the base, yet still makes it easy to remove.

Then to attach the miter saw, you'll need to drill a set of counter-bored holes (Figures 5 and 5b) to accept a set of T-nuts. To locate these holes, center the saw on the platform, mark each location and then drill the holes.

After installing the T-nuts, you can mount the saw with a set of hex bolts and washers (Figure 5b). Mounting the platform to the base is just a

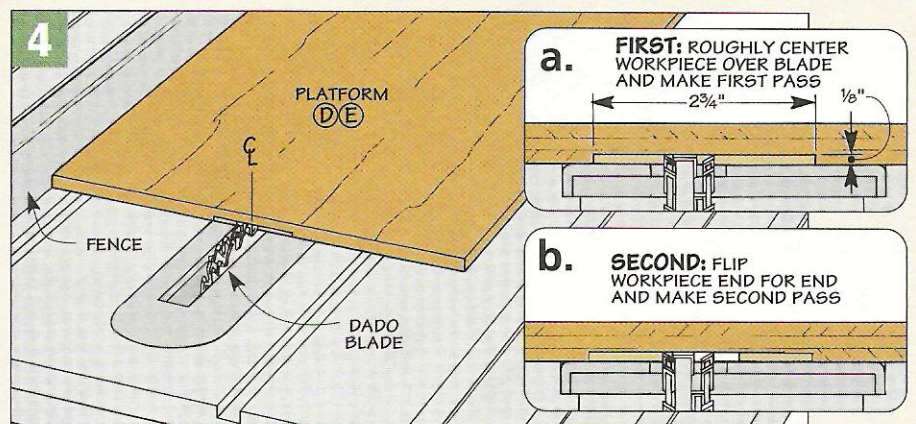
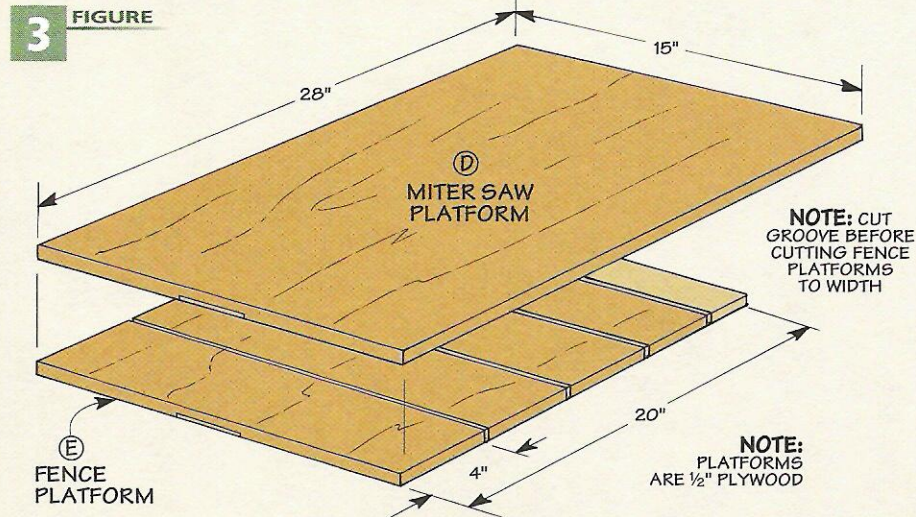

matter of slipping a pair of toilet bolts in the T-track and adding a couple washers and knobs.

Fence Platforms - There are still two things left to do to complete the fence platforms. First, you need to cut them to final length (Figure 3). And then you can drill a centered hole near each edge for

attaching the platform to the base (Figure 5). Finally, mount each platform to the base with a toilet bolt, washer, and knob.

Handles - If you plan to move the station fairly often, it's a good idea to add a set of handles to make it easy to carry. They're attached to the back stiffener (Figure 1).

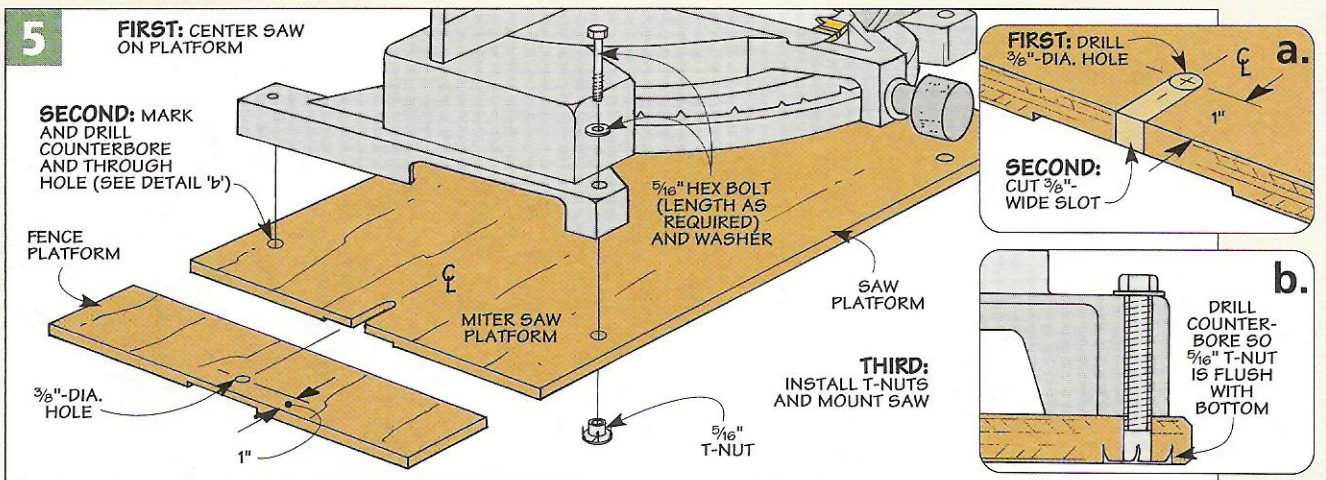

Fence System

6 OVERVIEW

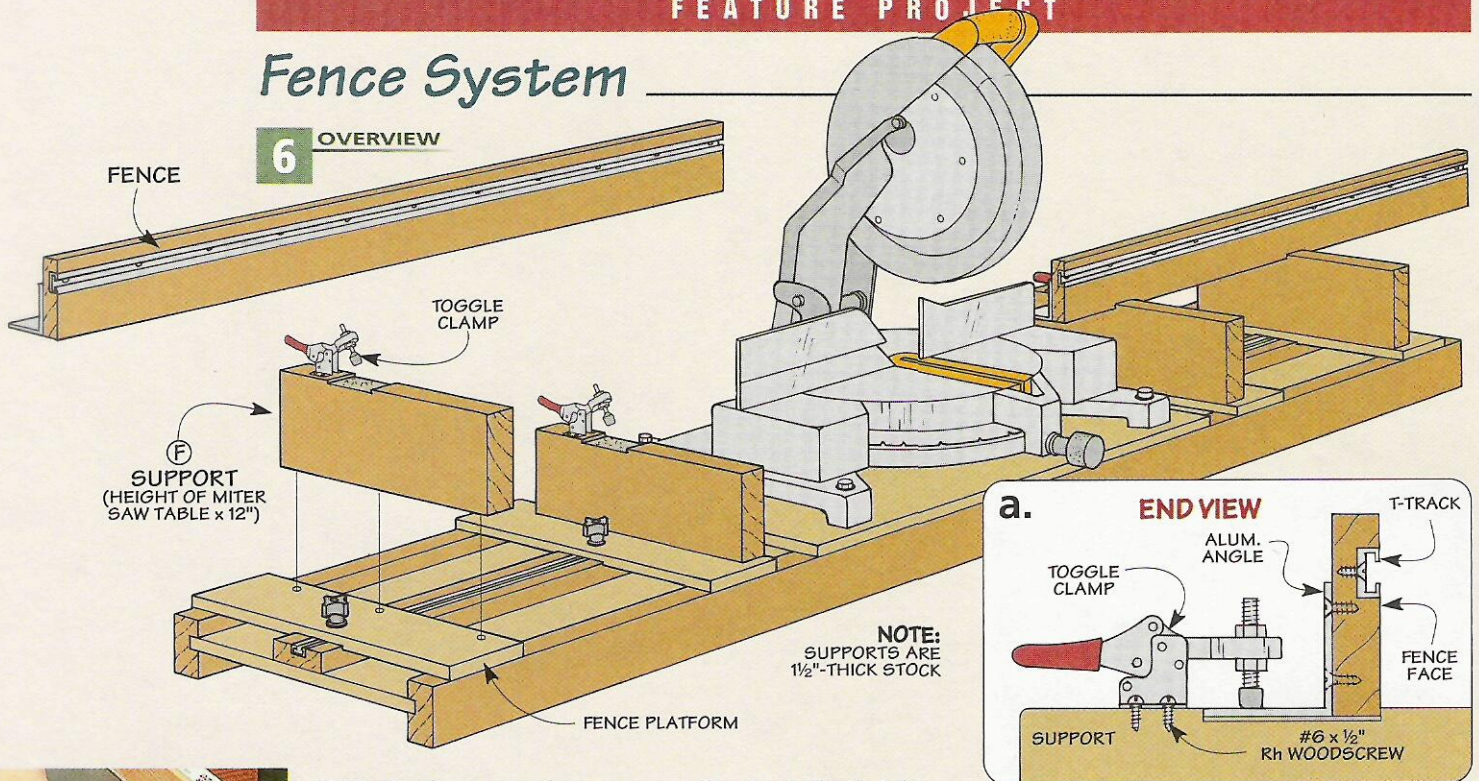

▲ Small toggle clamps make it easy to quickly adjust the position of the supports and fences.

With the base complete, you can turn your attention to the fence system. This system consists of two main parts — a set of workpiece supports, and a pair of fences.

Supports – The supports (F) are nothing more than short lengths of 2x stock cut 12" long. What's critical is the height — they need to match the height of your saw table so they keep the workpiece level.

The easiest way to establish this height is to start with an oversized workpiece. Then it's just a matter of sneaking up on the final width (height) by trimming a little off the edge of the support.

To check the height as you're trimming, place a straight-edge across the saw table and the support (Figure 7). Once the straight-edge rests level on both the support and the saw table, you can cut the rest of the supports to final width.

Alignment Notch – One thing I was concerned about was making sure the face of the fence would be easy to align with the miter saw — no matter where the supports and fences were positioned along the base. An easy way to do this is to cut a shallow ($1/8$ ") notch in the top edge of each support to accept the fence, as you can see in Figure 6a.

Here again, I used a straightedge to locate the position of the notch.

Note: The support will be set in from the front edge of the platform slightly ($1/2$ "). To do this, place the straight-edge against the fence of the miter saw and mark the location of the front edge of the notch (Figure 8).

With the front edge of the notch marked, you're ready to cut the notches in all four supports (Figures 9 and 9a). The notches are sized to accept the aluminum angle and solid wood face of the fence (added later). (In my case, this was $2^{3/4}$ ")

Attach Supports – The next step is to attach the supports to the fence platforms, as shown in Figure 10. They're screwed to the platforms so they're flush with the inside edge

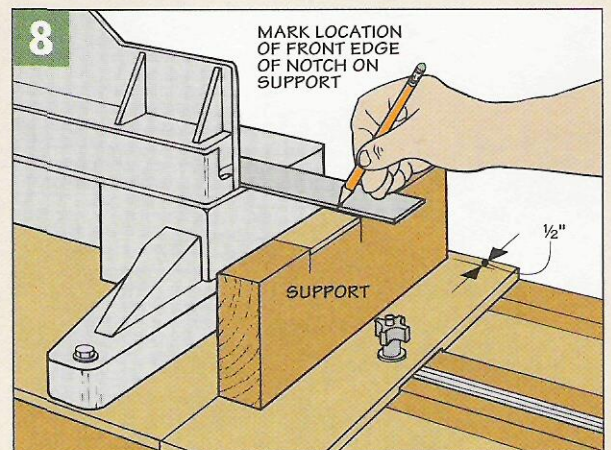
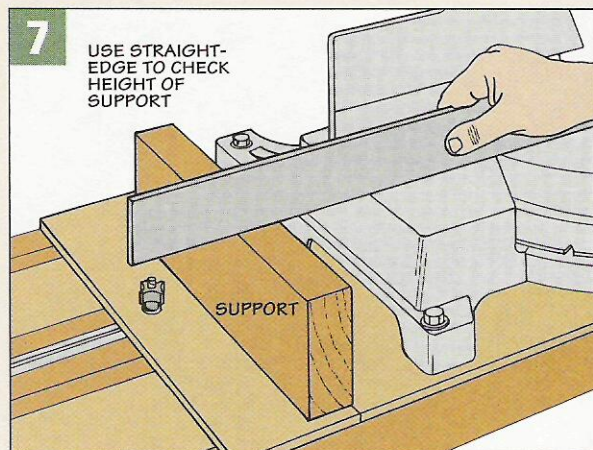

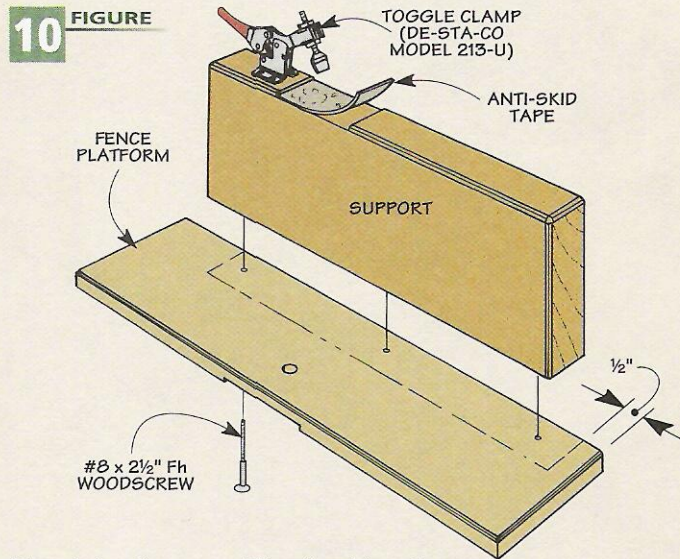
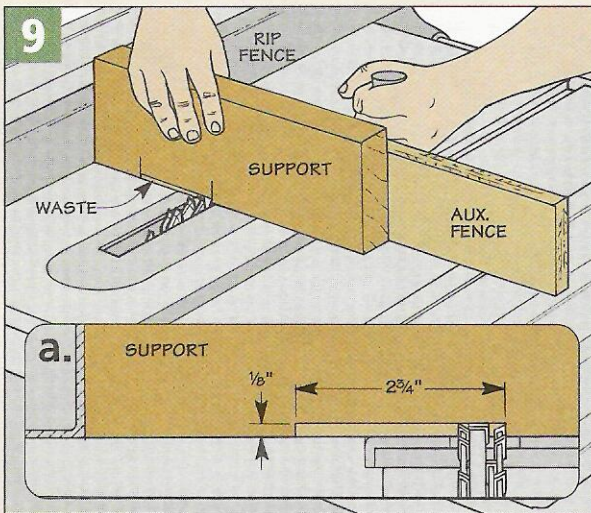

of the platform. Don't forget to set them back 1/2".

Toggle Clamps – To make it quick and easy to lock the fence in place, I added a toggle clamp to the back end of each support (Figure 6a). (I used a De-Sta-Co model 213-U.) To ensure the fence didn't slide around during use, I added some anti-skid tape to the bottom of each notch (Figure 10).

FENCES

With the supports complete and toggle clamps screwed in place, you've laid the groundwork for the two fences shown in Figure 6.

Fence – Each fence is made up of only three parts – an aluminum angle, a solid wood face, and a single piece of T-track (Figure 11). The T-track accepts an adjustable stop that's added later.

Unless you're able to find the aluminum angle already cut to final length (3'), you'll need to cut it to size. A carbide-tipped saw blade makes quick work of this.

With the angles cut to final length, cut the *fence faces* (G) to the same length from 1x stock, as shown in Figure 11. But before attaching the faces to the aluminum angle, you'll need to cut a shallow groove near the top edge of each face to accept the T-track (Figure 11).

After the grooves are complete,

you can screw the T-track in place. Then all that's left to do to complete the fence is to attach the wood face to the aluminum angle. It's screwed from the back so the face is flush with the bottom edge of the angle, as shown in Figure 6a.

Optional Long Fence – If you have to cut a lot of long stock to identical length, you might want to consider making a longer fence like the one shown in the photo below.

The nice thing about building a long fence is that it isn't much different than making a short one — just make everything longer. (I made my fence 6' long to accept two pieces of T-track.)

After cutting the groove for the T-tracks and screwing them in place, completing the long fence is just a matter of attaching the *face* (H) to a longer piece of aluminum angle just like you did before.

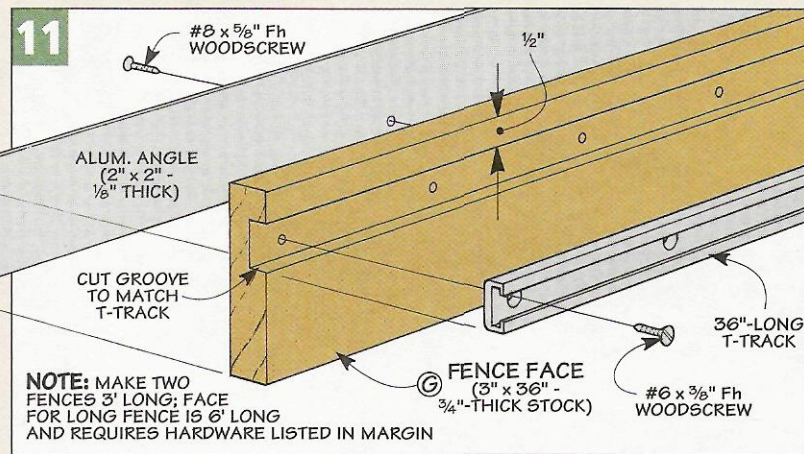

Optional Long Fence Hardware

- (2) Alum. T-Tracks (36" Long)
- (22) #6 x 3/8" Fh Woodscrews
- (7) #8 x 5/8" Fh Woodscrews
- (1) 2" Alum. Angle (72" Long)
- (1) 8' Left-to-Right Tape

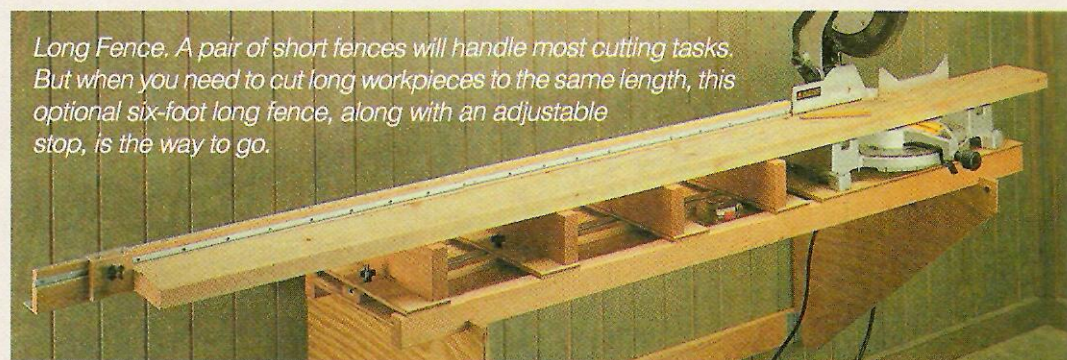

Stop

One of the most useful features of this miter station is the adjustable stop that works on either side of the fence. Along with a tape measure installed on the top of each fence, it makes cutting multiple workpieces to the same length a snap.

Adjustment Block – As you can see in Figure 12, the *adjustment block* (I) is made from a small piece of 3/4"-thick stock. To prevent the block from turning as you slide it along the fence, there's an alignment key that fits into a groove in the block.

But you don't want to cut a groove like this in such a small workpiece. So to avoid this, I started with an extra-long workpiece that's cut to width. Then it's a simple matter to cut the groove for the key (Figures 13 and 13a).

Once the groove is complete, you can cut the adjustment block to final length. Then all that's left to do is to fill the groove with an *alignment key* (J) cut from a piece of 1/4" hardboard.

An adjustable stop isn't much use without a way to lock it in position. To do this, there's a toilet bolt that slips into the T-track on the fence and passes through the block. A turn of a knob locks the block in place (End View in Figure 12). Note: Clamp the adjustment block in a handscrew to hold it steady when drilling the

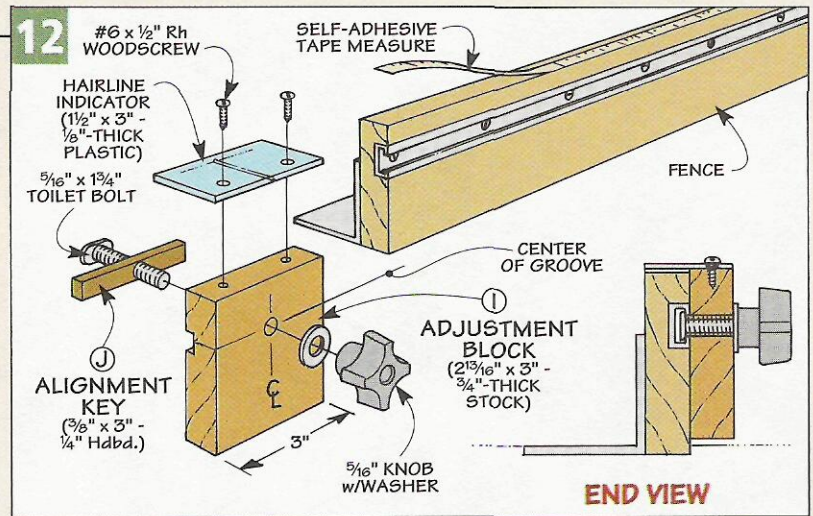

▲ To produce accurate results, this adjustable stop combines a sliding wood block with a plastic hairline indicator.

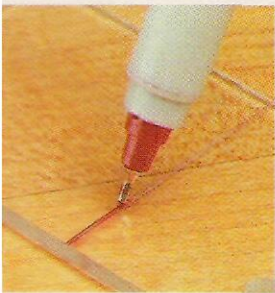

▲ To make the hairline stand out on the indicator, fill in the line with a permanent marker and then wipe off any excess.

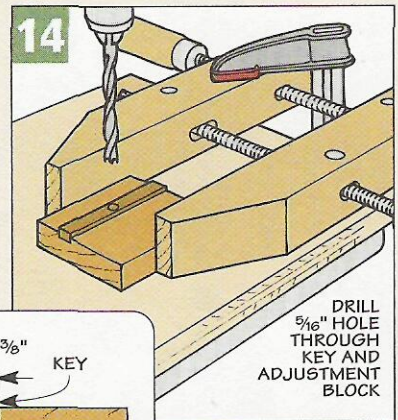
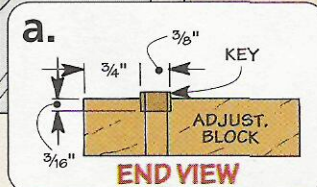
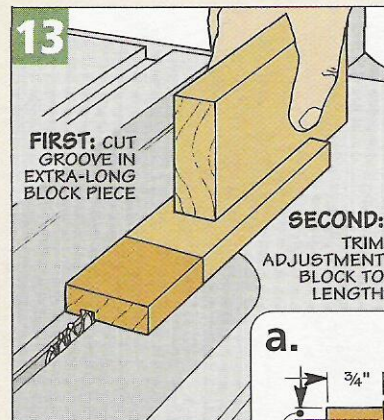

hole for the toilet bolt (Figure 14).

Indicator – To increase the accuracy of the stop, I added a hairline indicator made from 1/8"-thick plastic, as shown in Figure 12. What makes this indicator accurate is the hairline scored on the *bottom* of the

indicator. To make it easier to see the hairline, I filled it in with a marker (see margin photo) and then screwed the indicator to the top of the adjustment block.

Add Tape Measures – The hairline works with a tape measure installed on the top of each fence. (One reads right-to-left, the other left-to-right.) Putting the tape down is easy, the trick is locating it accurately.

To do this, I used a 12"-long scrap as a gauge. Start with the scrap resting against the teeth of the saw blade (Figure 15). Then slide the stop against the opposite end of the scrap and lock it in place.

After slipping the tape under the indicator, align the 12" mark with the hairline and press the tape in place (Figure 15a). To install the other tape, simply repeat the process. Finally, trim the ends of the tape flush with each end of the fence.

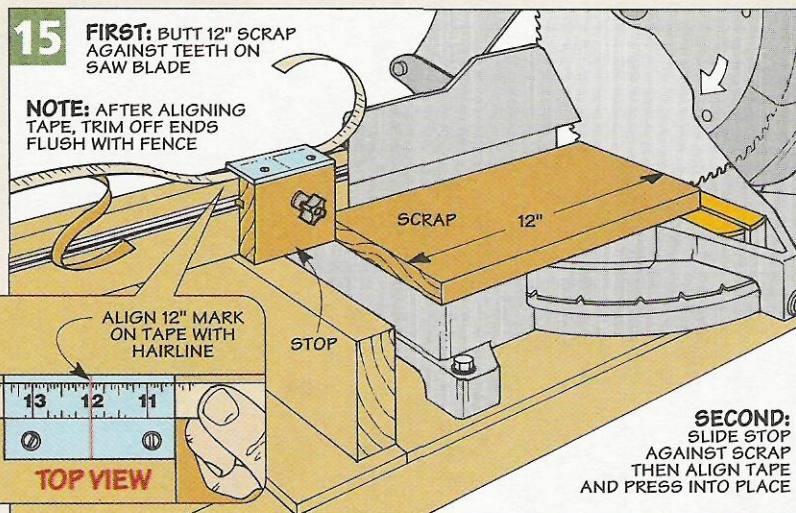

Wall Bracket

16 OVERVIEW

NOTE: CENTER AND POSITION BOTTOM CLEAT ABOUT 20" FROM TOP OF RAIL

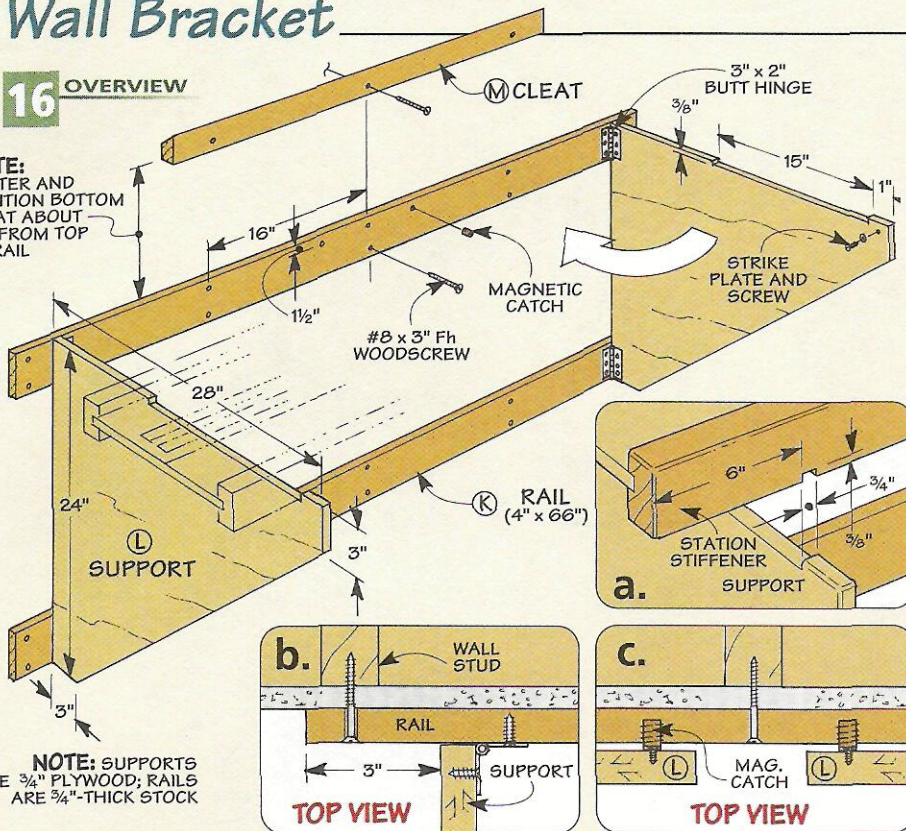

NOTE: SUPPORTS ARE 3/4" PLYWOOD; RAILS ARE 3/4"-THICK STOCK

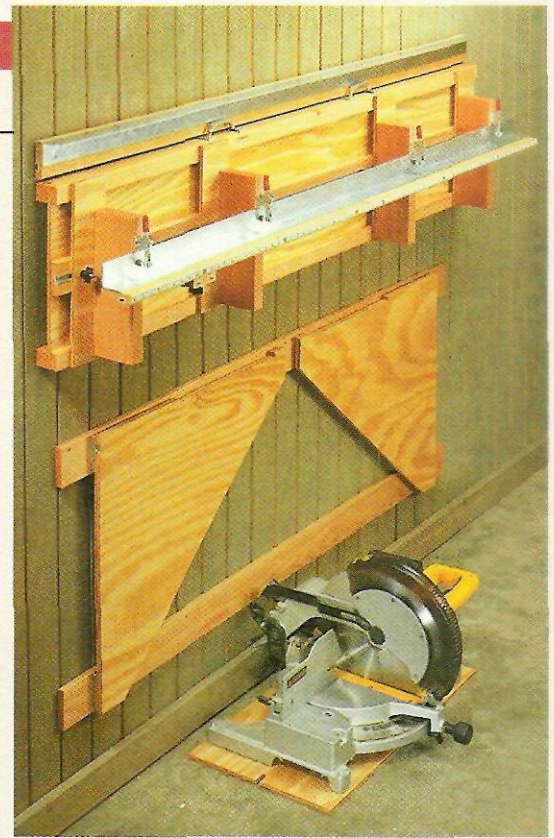

▲ After removing the miter saw, storing the station is just a matter of hanging it on a cleat and folding the supports for the station against the wall.

If you don't have the room to keep the miter saw set up on a benchtop, you might want to consider the wall bracket shown above. It doesn't take up any floor space because the station rests on supports that swing out from the wall. Once you're done using the station, simply hang the base on a cleat attached to the wall and swing the supports back in place, as shown in the photo at right.

Rails - I started on the wall bracket by making the rails (K). There's nothing special about them. Each rail is nothing more than a piece of 1x stock cut to final size.

Supports - With the rails complete, I turned my attention to the supports. The supports (L) are made from triangular-shaped pieces of 3/4" plywood with a shallow notch cut in the top edge (Figure 16). This notch is sized to accept the base of the miter saw station and prevents it from sliding off the front of the supports.

Installation - The main challenge in building the wall bracket is installing it. That's because it's fairly large once it's assembled. So instead,

I started by mounting just the rails to the wall (Figures 16 and 16b).

The only thing that's critical is the height of the top rail. I wanted the top of my miter saw table about 38" from the floor, which is a comfortable working height for me. So I placed the top rail 32" from the floor and then spaced the lower rail 16" below that. Note: Be sure to screw the rails into the wall studs (Figures 16 and 16b).

Completing the assembly is just a matter of mounting the supports to the rails. To do this, first attach the hinges to the supports and then screw them to the rails (Figures 16 and 16b). Finally, add a pair of magnetic catches to hold the supports closed for storage (Figure 16c).

Notch Base - As I mentioned before, the notch in the supports keeps the base from sliding off the supports. But to "lock" it in and keep it from moving side to side, I added notches to the base (Figure 16a).

Cleats - All that's left to do at this point is to make a pair of interlocking cleats that allow you to store the station on the wall (Figure 17).

Each cleat (M) is identical and cut from 2x stock. I planed them to fit between the base of the station and the wall (Figure 17a). To allow the cleats to lock together, there's a 45° bevel cut along one edge.

Finally, glue one cleat to the base of the station and screw the other one to the wall (Figure 16). Here again, you'll want to be sure to screw the cleat into the wall studs. ▲

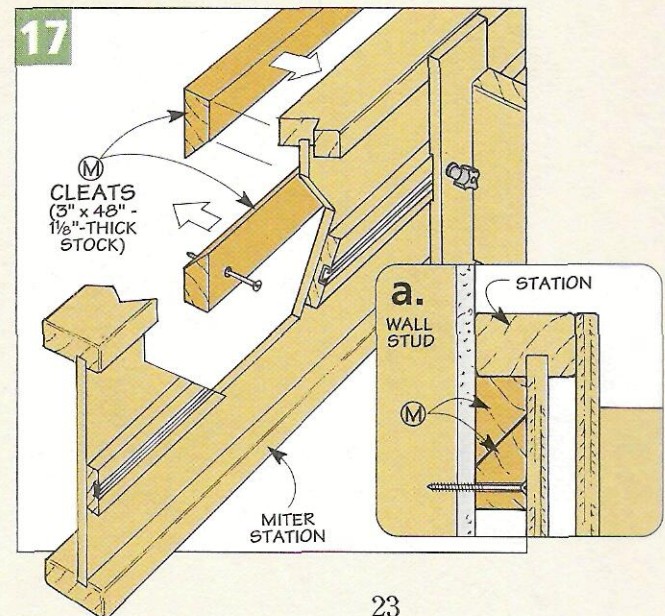

Table Saw Molding Heads

*Cut moldings on a table saw?
This simple accessory can
make it happen.*



Before routers and router tables became fixtures in most shops, if you wanted to make your own moldings for a project, you basically had two choices. An expensive (and potentially dangerous) shaper, or a table saw fitted with a *molding head*. A molding head is really nothing more than a cutter head that holds various profiles of knives (cutters). It's designed to fit right on the arbor of your table saw, see the photo above. But for as simple as it looks, a molding head is quite a versatile table saw accessory.

Benefits – You don't see molding heads as often today, which is too bad really. Because they're a great tool for making profiles and can do some things a router just can't. For one thing, a molding head allows you to cut a profile in the face of a board, not just on the edge like a router.

Second, buying a molding head for your table saw is a lot cheaper than buying a router table and a bunch of router bits. For the cost of three or four fancy profile router bits, you can buy a molding head set that includes the cutterhead and eight sets of knives with different profiles.

Finally, a molding head is a good choice whenever it's more convenient to bring the workpiece to the tool, rather than the tool to the workpiece. Particularly with long pieces, cutting moldings on a table saw is

often much more convenient than on a router table, which typically have smaller table surface areas.

Cutter Head – Although they may look slightly different, all molding heads work on the same basic principle. The main body, or cutter head, is usually slotted to hold a set of three knives (although some cutter heads may hold only one or two knives). You can purchase the cutter head and knives separately, or as a set containing the head and a basic assortment of knives. Delta and Sears (Craftsman) sell two of the more common molding heads on the market (see page 31 for sources).

The Delta molding head is a thick, round, disk, turned out of solid steel, see photo below. The cutters fit into slots in the head and are locked in place with a large set screw.

In contrast, the Craftsman head (shown in the drawing on the opposite page) is cut from plate steel and

is larger in diameter. Because it is thinner than the Delta head, the Craftsman molding head comes with a thick, washer-like spacer that is placed on the saw arbor between the arbor flange and the cutter head.

Both brands of molding head work well, but because the Delta is smaller and more streamlined, it's a bit quieter than the Craftsman head. I also noticed that the Delta knives were ground a little nicer than the Craftsman knives.

Knives – The knives are made from high speed steel with various profiles ground on the edge. They slide into slots in the cutterhead and are secured with a socket screw. One downside of molding heads is that because the knives are steel, they dull very quickly if used on man-made materials such as particleboard or MDF. (For a molding head that uses carbide knives, see the box on the opposite page.)

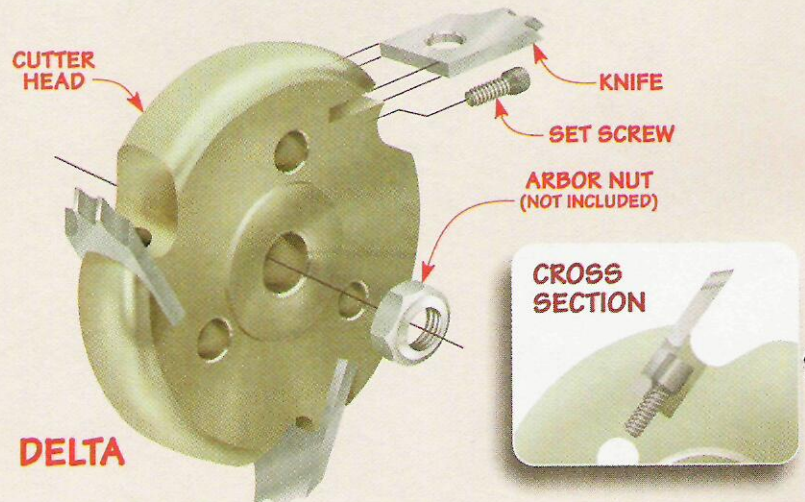

▲ **Profiles.** Here's just a small sampling of the many profiles available for your molding head.

Both Sears and Delta offer a good selection of knives (25 and 32 different profiles, respectively). These include coves, beads, flutes, quarter rounds, and ogees. Several of the knives combine two or more different shapes in the same profile, so they perform double-duty. There are also special knives available for tongue and groove joints and glue joints. The straight knives can be used for making rabbets or chamfers.

Knives for the Delta molding head cost about \$20 per set while the Craftsman knives are around \$12 per set. The two brands are not interchangeable. In other words, you can't use the Craftsman knives on a Delta molding head or vice versa.

Check Your Saw – Before purchasing a molding head, you might want to make sure that your table saw is capable of using one. The

arbor of the saw needs to be long enough to accommodate the molding head. As a general rule, if you can use a stacked dado head on your table saw, you should be able to use a molding head.

Inserts – The other piece of equipment you'll need is an insert plate for your table saw. You can purchase one or make your own (see the box on page 27). The insert for the molding head should have a wide opening to provide clearance for the cutters. Note: The opening required for a molding head is usually wider than the opening found on most dado inserts, so you can't necessarily use your dado insert.

One thing to note is that the Delta molding insert is designed to be used with the Delta molding head. The opening in this insert isn't long enough to accommodate the larger-diameter Craftsman molding head.

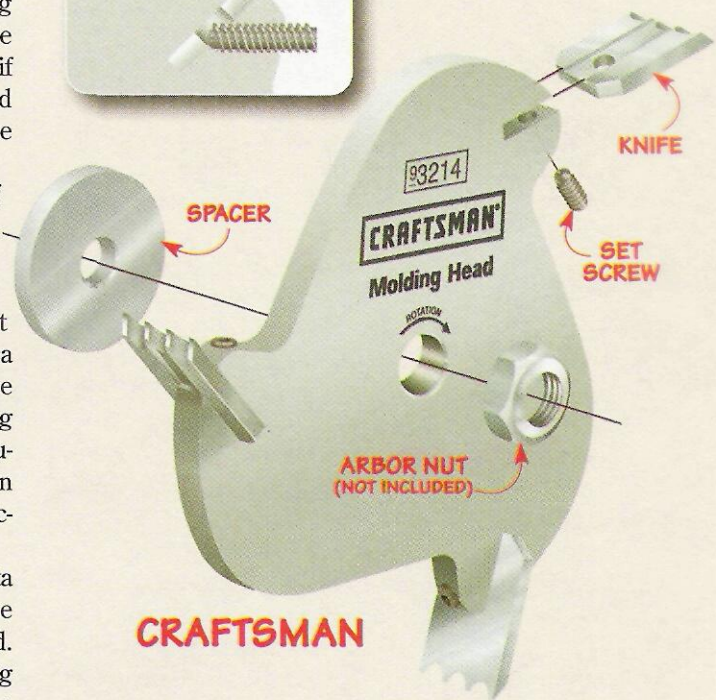
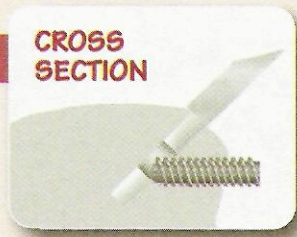

CRAFTSMAN

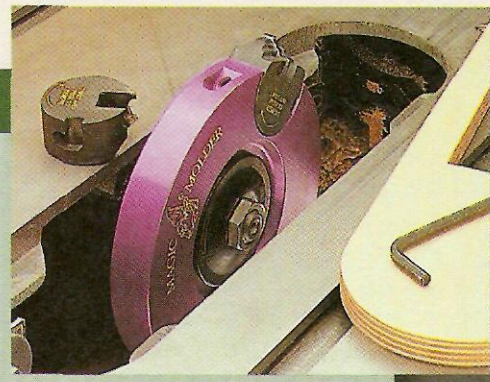

Magic Molder

With its bright purple exterior, the new "Magic Molder" certainly stands out from other molding heads. And the differences don't stop there. It has a lot of features that you won't find on traditional molding heads.

For one, the head is made out of anodized aluminum, perfectly

balanced so it will run smoothly and quietly. But the biggest improvements are in the knives. Instead of just flat, steel knives, the Magic Molder uses round "plugs" that have carbide cutters welded on. These plugs slide into openings

in the molding head and are

held in place by a steel locking pin and a set screw, making it virtually impossible for the plug to fly out. An anti-kickback plug design makes the Magic Molder even safer to use.

I tried the Magic Molder, and it worked, well, like magic. The moldings it creates look like they came right off a shaper.

The Magic Molder is a bit more expensive than other molding heads. But the cost is offset by the fact that the carbide cutters will last much longer than high speed steel. In addition, there are 70 different knife profiles available. See page 31 for sources.

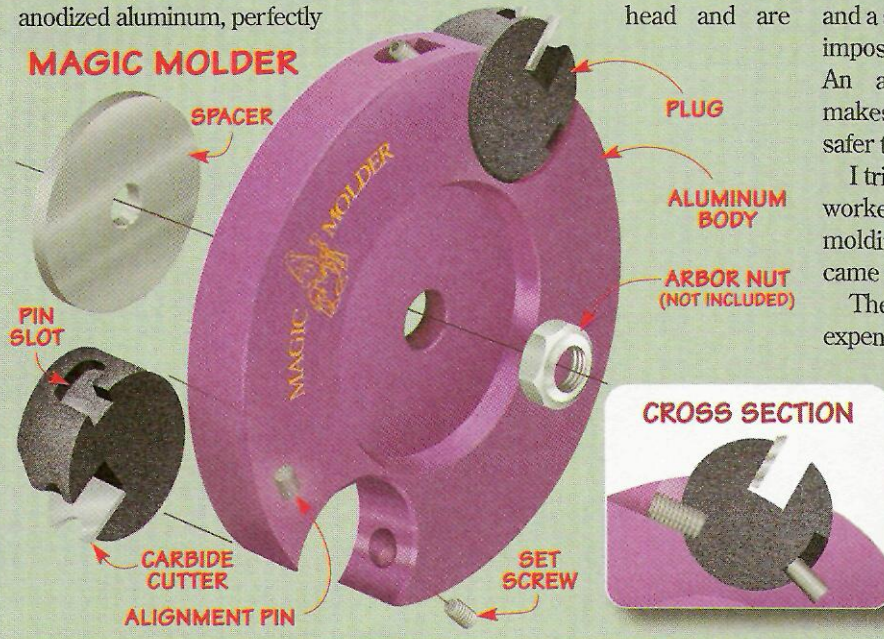

Using a Molding Head



▲ **Honing the Knives.** When the knives become dull, they can be resharpenered by honing the back (flat) side on a sharpening stone.

If you've never used a molding head before, it can seem a little intimidating (even frightening) at first. Part of this has to do with the sound of the molding head. Instead of the high-pitched "zing" of a saw blade, a molding head emits a low-pitched, whirring sound. But using a molding head is really no more dangerous than using a stacked dado set. The key to safety is to follow a few simple rules (see the box below) and to make sure you are always in control of the cut by using featherboards and hold-downs.

Edge Molding – Most of the time, I use a molding head for cutting a profile on the edge of a board. This is done by burying the molding head in an auxiliary fence so that only the portion of the knives that you want to use is exposed, see drawings at right. (This is the same way that you would bury a dado head for cutting a rabbet.) If you want to use the left side of the knife profile, you'll need to move the fence over to the right of the molding

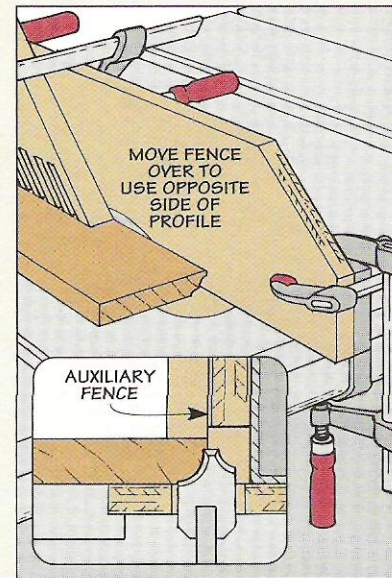
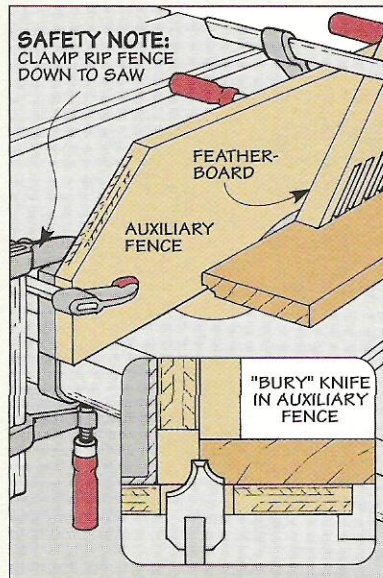

▲ **Double Duty.** Some molding head cutters have two different profiles in one. To use the second profile, you'll need to move the fence over to the opposite side of the molding head, as shown above.

head. Safety Note: To avoid an accidental kickback, you should never trap the workpiece between the fence and the molding head.

The auxiliary fence can be as simple as a piece of plywood clamped or screwed to your rip fence. An arc-shaped cutout along the bottom of the auxiliary fence provides clearance for the molding head. (For an auxiliary fence that incorporates a hold-down feature, see the article on page 28.)

Feed Rate – If you've never used a molding head before, you might want to make some practice cuts to get a "feel" for the best feed rate. If you feed the workpiece too fast, you'll wind up with a rough, uneven cut. Feed it too slow, and you may have trouble with burning. The key is to find the right feed rate and then push the workpiece through smoothly and continuously.

Pressure – In addition to the feed rate, you want to pay attention to the amount of downward pressure you apply to the workpiece. In

order to get a straight, even profile, you need to apply consistent pressure. The best way to do this is by attaching a featherboard (or two) to the auxiliary fence. Featherboards not only help produce more consistent results, they also serve as a safety device to prevent kickback.

Whenever possible, I prefer to run the workpiece through the saw lying flat. (I feel like I have more control over the workpiece this way.) But occasionally, the only way to get the

Safety Tips

1 Secure Knives. Make sure the knives are securely fastened in the cutter head. Don't operate the molding head with missing knives or knives with different profiles. It will throw off the balance of the cutter head.

2 Check Clearance. Rotate the molding head by hand before turning on the saw to make sure that the knives clear the insert and fence.

3 Multiple Passes. Avoid taking deep cuts. It's better to cut deep profiles in multiple passes.

4 Stock Size. Don't try to cut moldings on boards that are less than 4" wide or shorter than 12". If you need to make narrow moldings, cut the profile on a wide board first and then rip the molding to width.

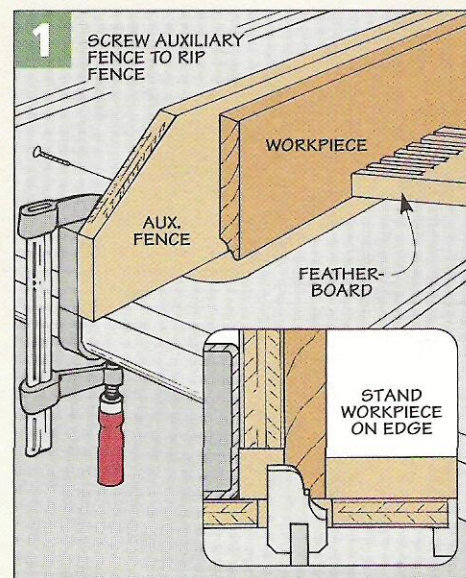

profile you want is to run the piece through on edge, like you see in Figure 1. To do this, make sure that your auxiliary fence is tall (wide) enough to support the workpiece. And instead of attaching the featherboards above the workpiece, attach them to your table saw so they hold the workpiece against the fence.

Making Complex Profiles – You don't need to be confined to the stock knife profiles that are available for your molding head. By combining multiple cuts using different knife profiles, you can come up with a wide variety of moldings.

To do this, start by penciling out the profile you want on the end of your stock. Then cut the molding by making separate passes using different profiles of cutters, as shown in Figure 2.

If the molding you're making requires removing a lot of material, it's best to cut the profile by taking a series of light passes, rather than one heavy one. This way, the molding head doesn't have to remove as much material, resulting in a cleaner, smoother cut that isn't so hard on the knives. The other

option is to rip off the bulk of the waste beforehand with a regular saw blade, as shown in Figure 2.

Joinery – Molding heads aren't just for making moldings. They can be used for joinery as well. There are straight knives that will cut rabbets and other knife sets that can be used for tongue and groove joints.

One of the more useful knife profiles is the glue joint knife shown in Figure 3. This profile is symmetrical, so once you set the position of the fence, you can run all your boards through, and they will come out with interlocking edge joints. This profile can also be used for creating interlocking drawer joints.

Maintenance – The only maintenance you need to perform on a molding head is to clean out any sawdust that may accumulate in the slots and periodically inspect it for any damage or stripped-out set screws. The cutters can be sharpened by rubbing the flat side on a sharpening stone, see photo on opposite page. But don't try to sharpen the beveled side of the cutters. It's too easy to alter the profile, which can throw the molding head off balance. 

2 FIGURE
FIRST: DRAW PROFILE ON END OF WORKPIECE

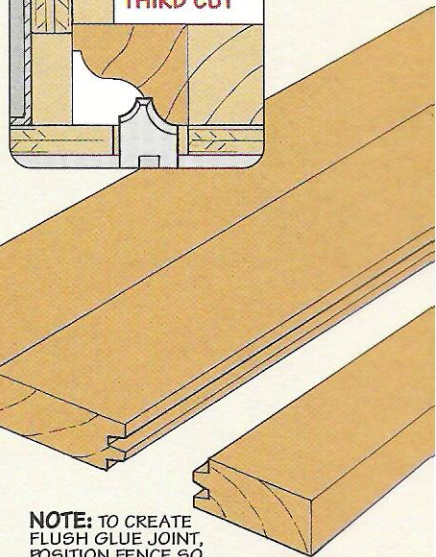
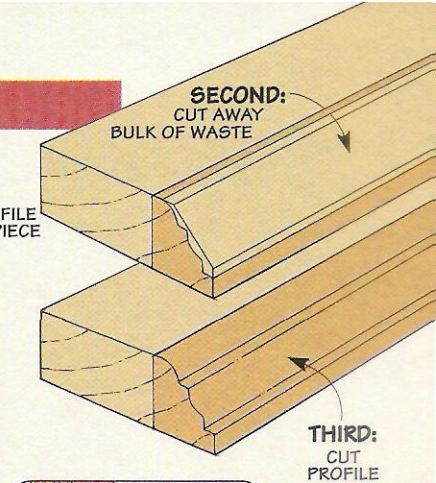
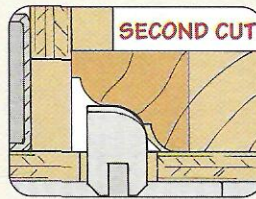
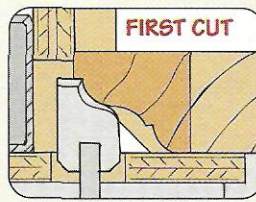

3 FIGURE

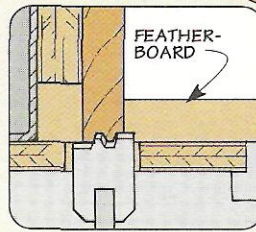

NOTE: TO CREATE FLUSH GLUE JOINT, POSITION FENCE SO WORKPIECES ARE CENTERED OVER CUTTER

Molding Head Insert

To use a molding head, you'll need an insert with a wide opening. Making your own molding head insert is really a pretty simple task, especially if you've made other types of inserts before. Start by cutting a blank to match the size and thickness of your regular table saw insert. (I used some 1/2" Baltic birch plywood, but you could also use solid wood.)

After cutting the blank to size so that it fits in the opening in your table saw, you need to make the opening for the molding head. The safest way to do this is to mark out the location of the opening on the blank and then cut it out with a sabre saw.

Using a straightedge, mark the front and back of the opening and then the sides, as you see in Figures 4 and 5. After drilling a starter hole and cutting out the waste, check to make sure the molding head will clear the opening before turning your table saw on.

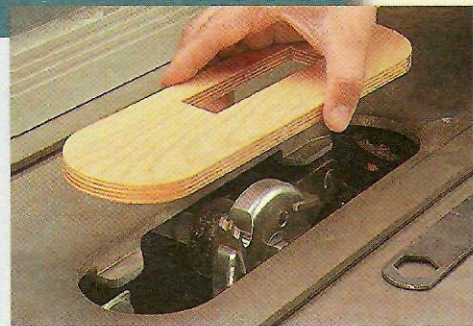
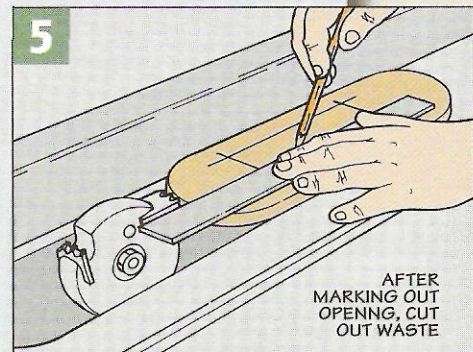
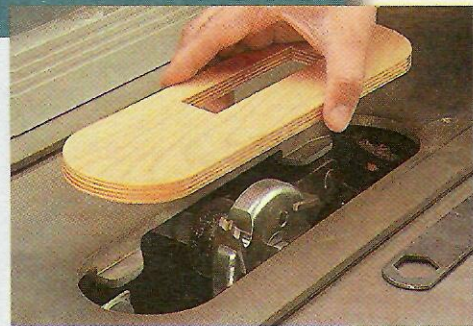
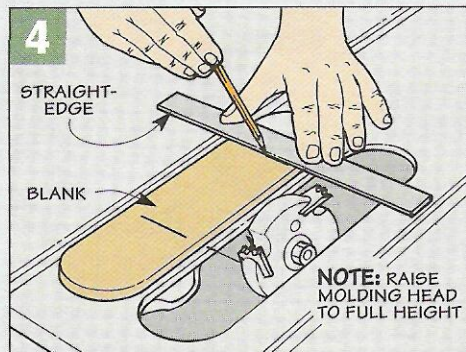

Molding Head Fence



A tall fence, built-in hold-downs, and a see-through guard put you in control of the cut.

The nice thing about using a molding head to make moldings is that you don't have to buy another expensive piece of equipment — the molding head attaches directly to the table saw you already own. But in order to cut moldings safely and effectively, you need to have an auxiliary fence like the one shown in the photo above.

This fence does two things. It allows you to “bury” the molding head in the rip fence so you can use

just a portion of the cutter profile. And it also serves as a hold-down for the workpiece, helping to prevent kickback. But the beautiful thing about this fence is that it's not just for molding heads. It can also be used for cutting rabbets with a dado head. It's one versatile fence.

The fence consists of two basic assemblies. A long face provides support for the workpiece and a couple of hold-downs slide in tracks

in the fence. The whole thing can be built in just a couple of hours.

Face – To make the fence, start by cutting a piece of $\frac{3}{4}$ " plywood to size for the face (A). The length of this piece should approximately match the length of your rip fence. Next, I trimmed off the front and back corners of the face so there wouldn't be any sharp corners.

An arc is made along the bottom of the face to provide clearance for the molding head and its cutters. To determine the location of this cutout, clamp the face to the rip fence on your table saw. Then with the saw turned off and unplugged for safety, raise the molding head into position and slide the fence over against it. Now you can mark out the location of the cutout on the face. (I used a sabre saw to do this.)

T-Tracks – Once you've finished cutting the arc, the next step is to mount a couple of aluminum T-tracks in the face for the hold-downs (see page 31 for T-track sources). The T-tracks fit into dadoes that are

1 EXPLODED VIEW

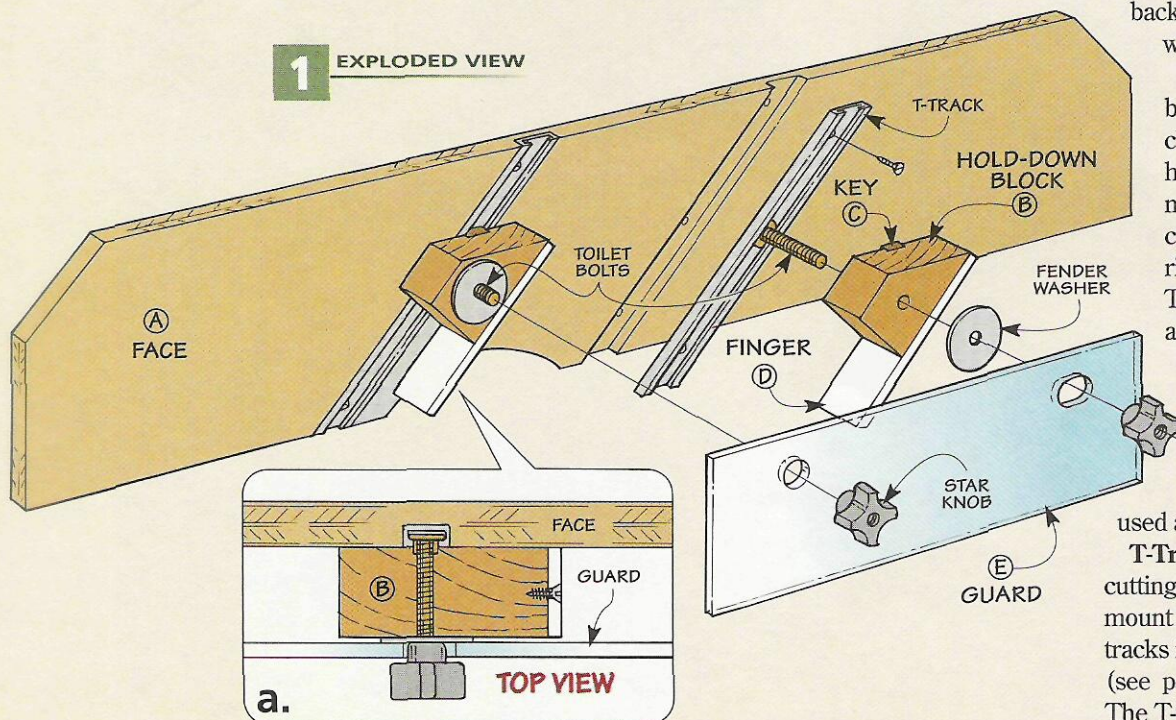

cut in one side of the plywood face. To make these dados, I used my miter gauge to guide the workpiece over a dado blade, as shown in Figure 3. An auxiliary fence attached to the miter gauge helps to support the workpiece. And a stop block clamped to the auxiliary fence prevents the workpiece from slipping.

Once you've cut both dados, the T-track can be mitered to length and screwed in place. Since the T-track is aluminum, you can cut it on a table saw using a carbide-tipped blade. But if you don't have a carbide blade, you could use a hacksaw instead.

Hold-Downs – The hold-downs are nothing but a couple of hardwood blocks with a key inset in each to slide in the T-track. The blocks (B) start off as a single, extra-long blank of 1½"-thick stock, like you see in Figure 4. A shallow groove is cut down the center of the blank, and then a hardboard key (C) is glued into the groove.

The hold-down blocks will be attached to the T-track with knobs and 2¼"-long toilet bolts. So the next step is to drill a hole through each block for the toilet bolt. After this is done, the hold-down blocks can be cut from the blank.

The last thing to do is to add a "finger" to each hold-down block. This is the piece that will actually press against the workpiece, holding it flat against the table. I could have

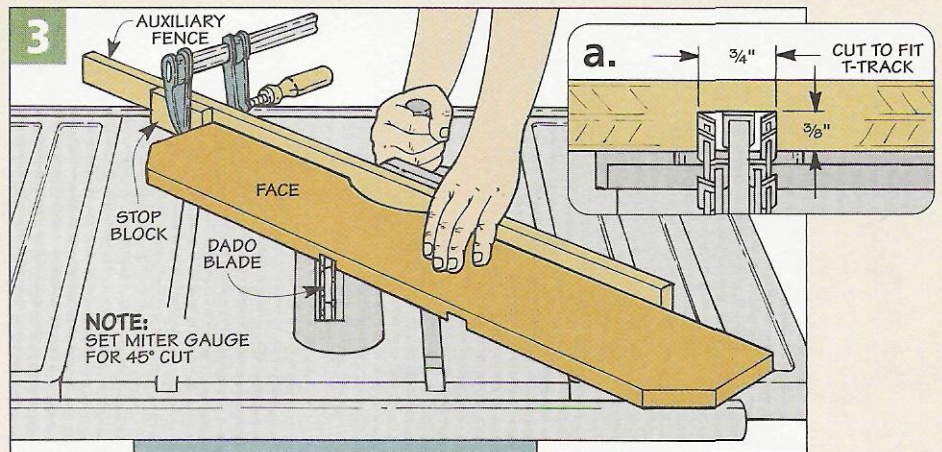
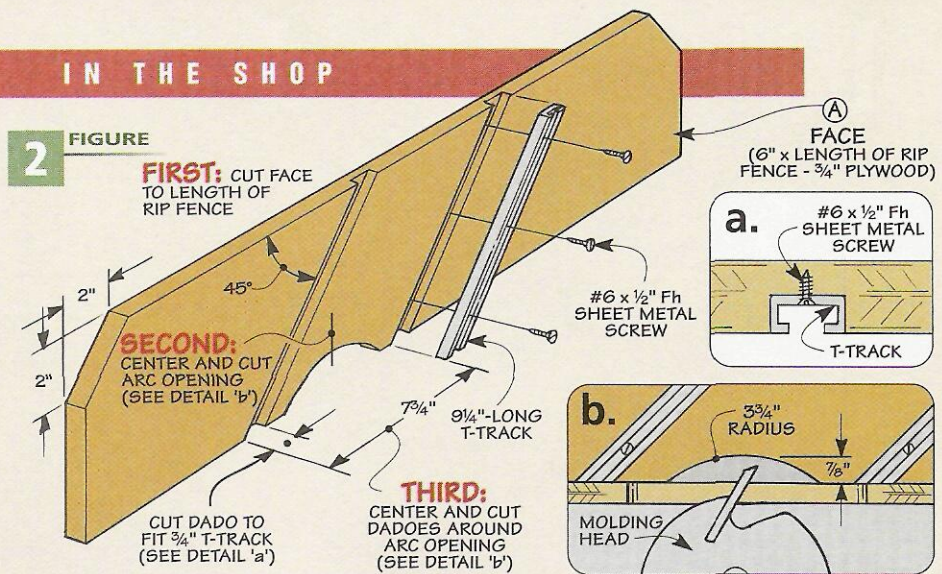

made the fingers out of wood. But because I didn't want to have to worry about them breaking, I used a tough plastic instead — UHMW (Ultra-High Molecular Weight). (Sources for UHMW plastic are listed in the margin on page 30.)

In addition to being stiff and

springy, this plastic is also very slick, which makes it a good choice for the hold-down fingers. The fingers (D) are cut to size on the table saw. Then after rounding over the leading edge of each finger with some sandpaper, the fingers can be screwed to the hold-down blocks (Figure 5).

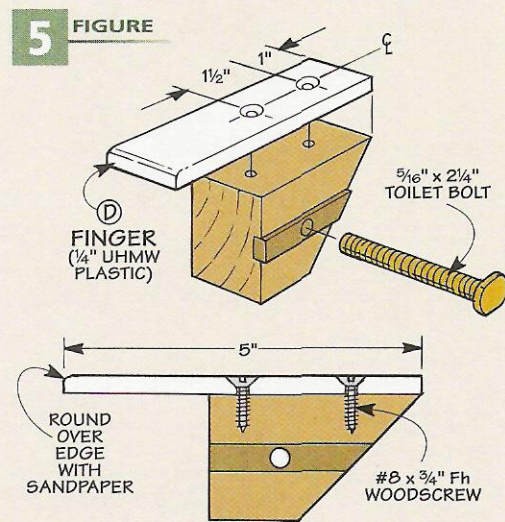
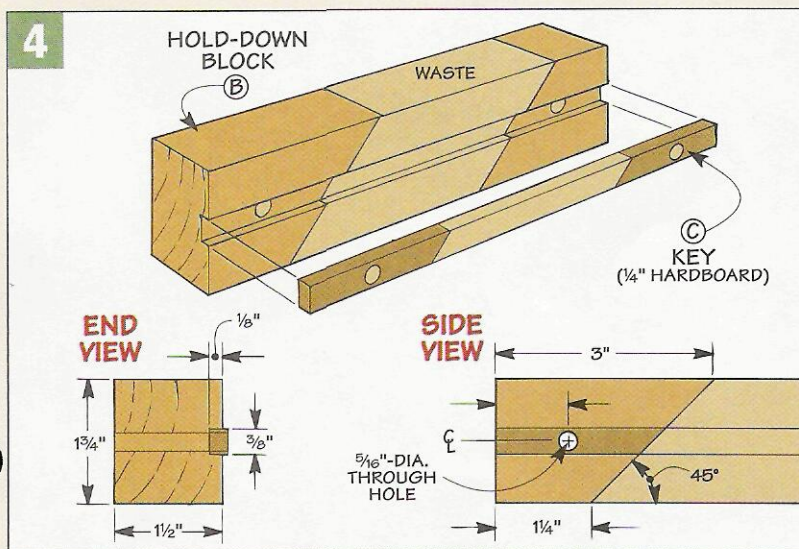

Guard

SOURCES

Lee Valley
800-871-8158
UHMW Plastic,
Polycarbonate
(Lexan)

Rockler
800-279-4441
UHMW Plastic

The hold-downs go a long way toward reducing the chances of kick-back when using a molding head. But for an extra measure of protection, I decided to add a guard to the hold-down blocks. This is just a piece of clear polycarbonate (Lexan) that slips over the toilet bolts that are used to attach the hold-down blocks, (Figure 6). For a source of polycarbonate, see the margin at left.

To make the *guard (E)*, all you have to do is cut the polycarbonate to size and make a couple of holes in it. The guard actually hangs from a couple of star knobs that are used to secure the hold-downs. The holes are oversized to allow the guard to fit

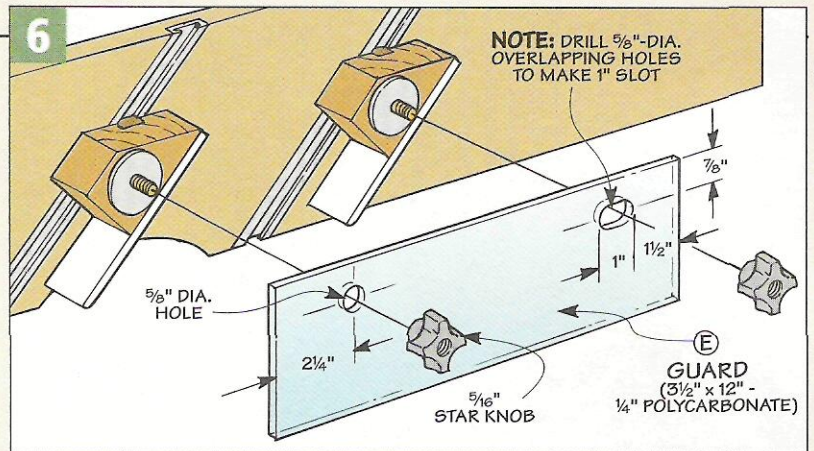

over the base of the knobs. And one hole is slightly elongated so the guard and hold-downs will slide smoothly in the T-tracks without binding. To make this elongated

hole, I drilled two overlapping holes. Once the guard is complete, you can attach the hold-downs and guard to the fence with toilet bolts, fender washers, and a couple of star knobs.

Using the Molding Fence

Using the molding fence is pretty straightforward. It's simply a matter of attaching it to your rip fence and adjusting the hold-downs.

The first step is to clamp the fence to your rip fence, as shown in Figure 7. Nothing tricky here. Just make sure that the clamps are positioned high enough so they won't be in the way of your workpiece. (Depending on the design of your rip fence, you may be able to attach the fence with screws.)

Next, you'll need to position the fence. Depending on the cutters you are using, you may only want to use a portion of the cutter profile. The molding fence will cover the unused portion of the profile, just like you see in Figure 7a.

Once you have the fence positioned where you want it, clamp the back end of the fence down to the table. Safety Note: Clamping the fence down is necessary to prevent it from being lifted off the table by

the force of the molding head.

Adjust Hold-Downs – The final step is to adjust the hold-downs. This is just a matter of placing your workpiece against the face of the fence, loosening the knobs, lowering the hold-downs until the fingers contact the workpiece, and then tightening the knobs (Figures 8 and 8a). The fingers should hold the workpiece down firmly, but not so tight that it becomes difficult to feed the stock under them.

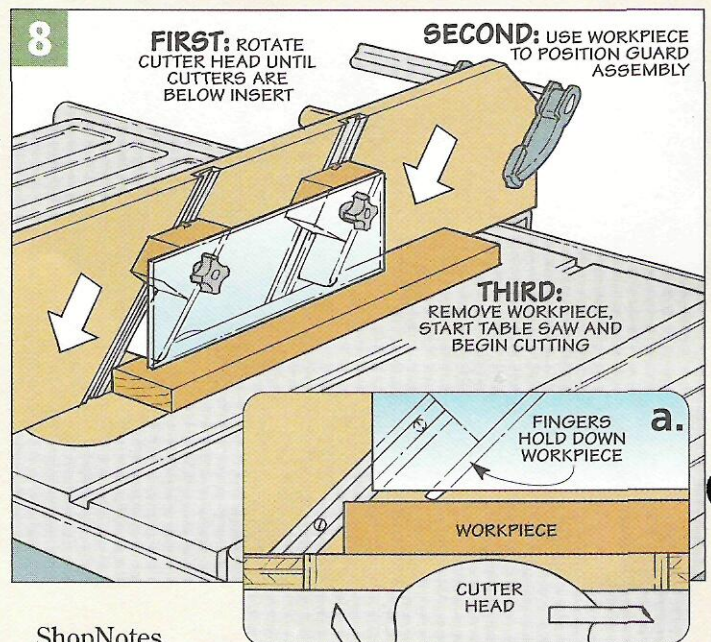
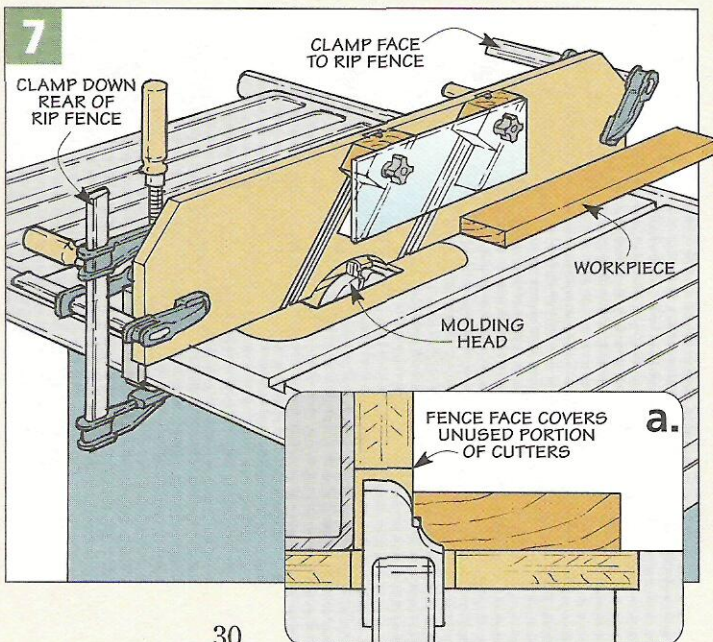

Sources

PRODUCT INFORMATION

Polyurethane Glue ▶

You can increase your odds of a successful glue-up by keeping a bottle of polyurethane glue around the shop. The biggest advantage is they have a longer open time than your typical woodworking glue, so you'll have more time to assemble a complex project. But they're also strong and easy to clean up once they've dried. You can find polyurethane glues at woodworking stores, home centers, or the following mail-order sources:

- Lee Valley 800-871-8158
- Rockler 800-279-4441
- Woodcraft 800-225-1153
- Woodworker's Supply 800-645-9292



◀ Miter Saw Station Parts

ShopNotes Project Supplies is offering some of the more difficult to find hardware for the Miter Saw Station shown on page 16. Besides the aluminum T-track (four required), you can also order a hardware kit that contains the seven toilet bolts, star knobs, and washers required to build the miter saw station.

Most woodworking stores and catalogs carry the toggle clamps (De-Sta-Co Model 213-U) and self-adhesive measuring tapes in a variety of lengths that read both left-to-right and right-to-left. Note: The Woodsmith Store (800-835-5084) carries both the toggle clamps and measuring tapes.

All the remaining hardware (aluminum angle, woodscrews, hinges, handles, T-nuts, anti-skid tape, piece of Plexiglas, magnetic catches, and hex bolts) is available at many hardware stores and home centers.

36" T-TRACK (Each)

4502-076.....\$13.95

HARDWARE KIT (7 Each of Knobs, Toilet Bolts, and Washers)

6858-125.....\$10.95

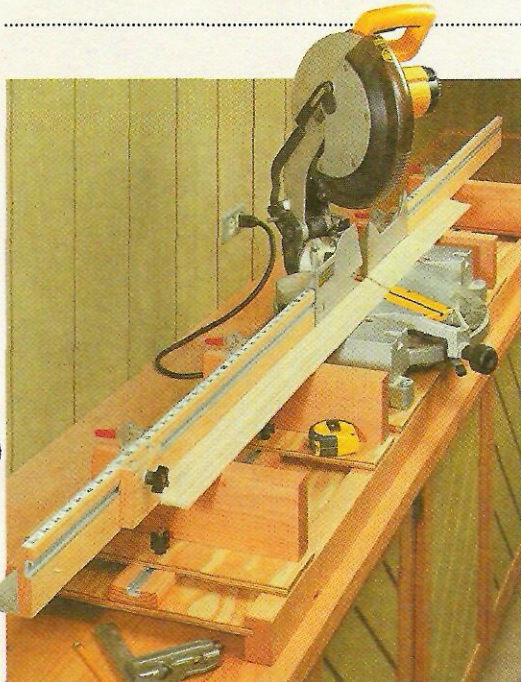

Molding Head Cutters ▶

Molding head cutters can add a whole new dimension to your woodworking, whether you're adding a unique profile to a special project or creating hundreds of feet of trimwork. In addition, there are a wide variety of cutters available (see margin). Molding heads are available at woodworking stores or the following mail-order sources:

ShopNotes Project Supplies is offering some of the hardware and supplies needed to build the projects in this issue.

To place an order for some of the items shown on this page, call:

800-347-5105

(Key Code: SN 58)



Delta

Craftsman

Magic Molder

- Sears (Craftsman) 800-377-7414
- Woodhaven (Magic Molder) 800-344-6657
- Woodworker's Supply (Delta, Magic Molder) 800-645-9292
- LRH Enterprises, Inc. (Magic Molder) 800-423-2544

Scenes from the Shop

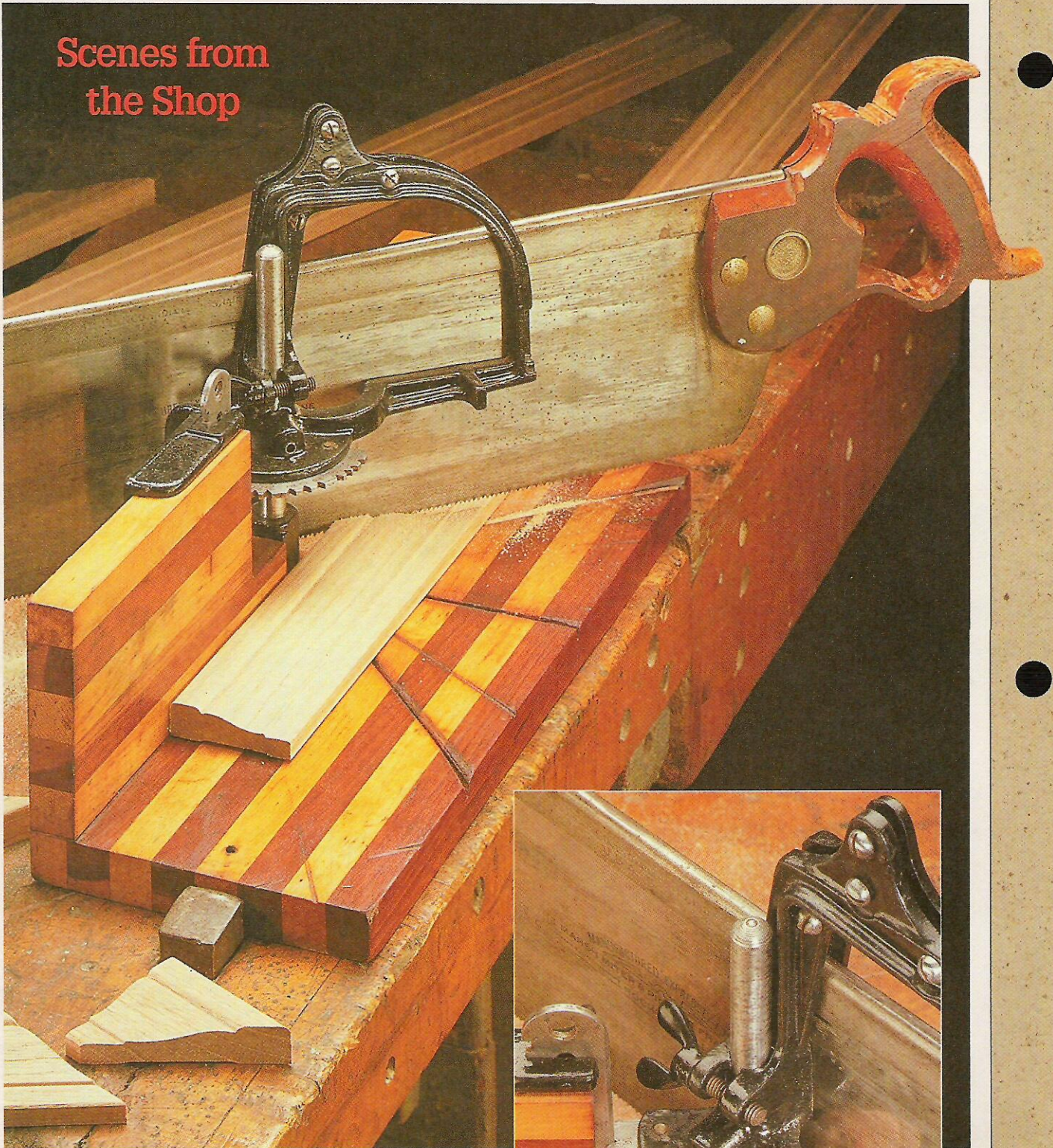

Sold by Sears, Roebuck & Co., this Dunlap miter box was used to guide a hand saw when cutting miters. The saw slides back and forth in a cast iron guide which can be adjusted for any angle. Commonly-used angles can be set automatically by sliding a key into one of several notches in a plate attached to the guide.

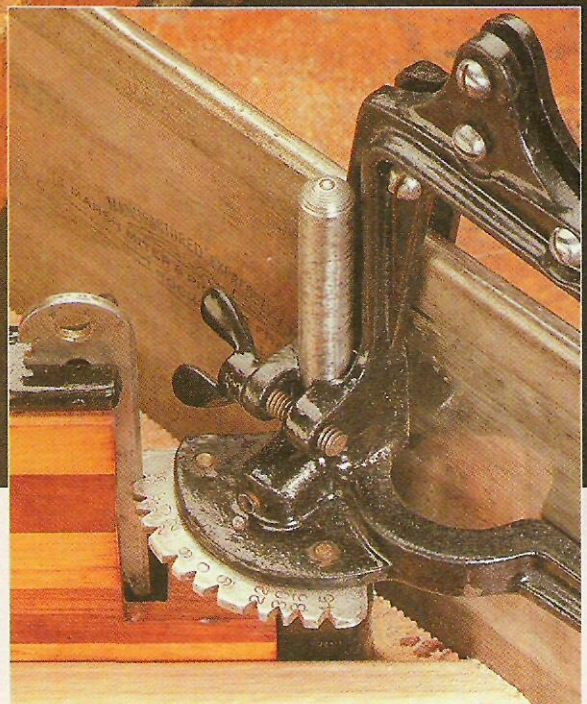



Cordless Tool Storage

Cutting Diagram

48" x 96" - 1/2" PLYWOOD

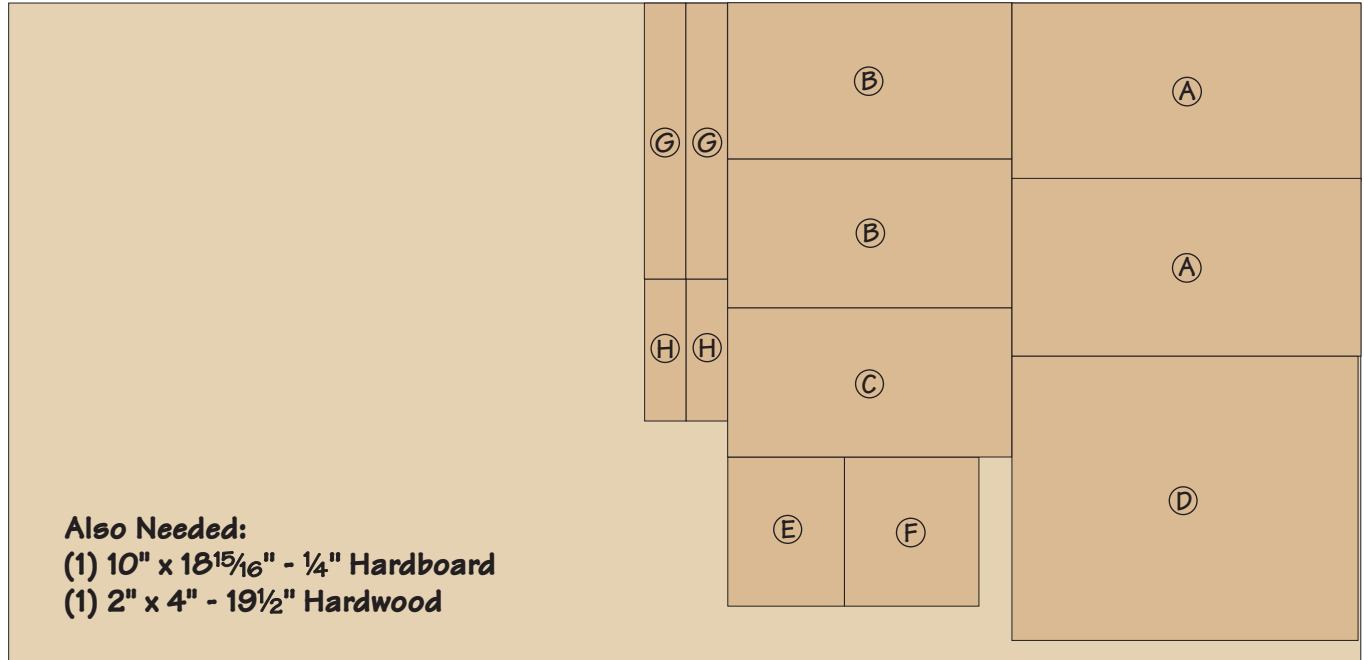

Materials

Storage Cabinet

A Sides (2)	12 ¹ / ₂ x 24 ¹ / ₂ - 1/2 Plywood
B Shelves (2)	10 ¹ / ₂ x 20 - 1/2 Plywood
C Bottom (1)	11 x 20 - 1/2 Plywood
D Back (1)	20 x 24 ¹ / ₄ - 1/2 Plywood
E Support (1)	10 ¹ / ₂ x 8 ¹ / ₄ - 1/2 Plywood Platform
F Platform (1)	9 ¹ / ₂ x 10 ¹ / ₂ - 1/2 Plywood Upright
G Drawer Front/Back (2)	2 ¹⁵ / ₁₆ x 19 ⁷ / ₁₆ - 1/2 Plywood
H Drawer Sides (2)	2 ¹⁵ / ₁₆ x 10 - 1/2 Plywood
I Drawer Bottom (1)	10 x 18 ¹⁵ / ₁₆ - 1/4 Hardboard
J Cleats (2)	1 ¹ / ₂ x 3 - 19 ¹ / ₂ Hardwood