

LEARN THE
SECRETS TO CUTTING
Perfect Half Laps

SPECIAL: SHOP STORAGE ISSUE

ShopNotes[®]

Vol. 10

Issue 59

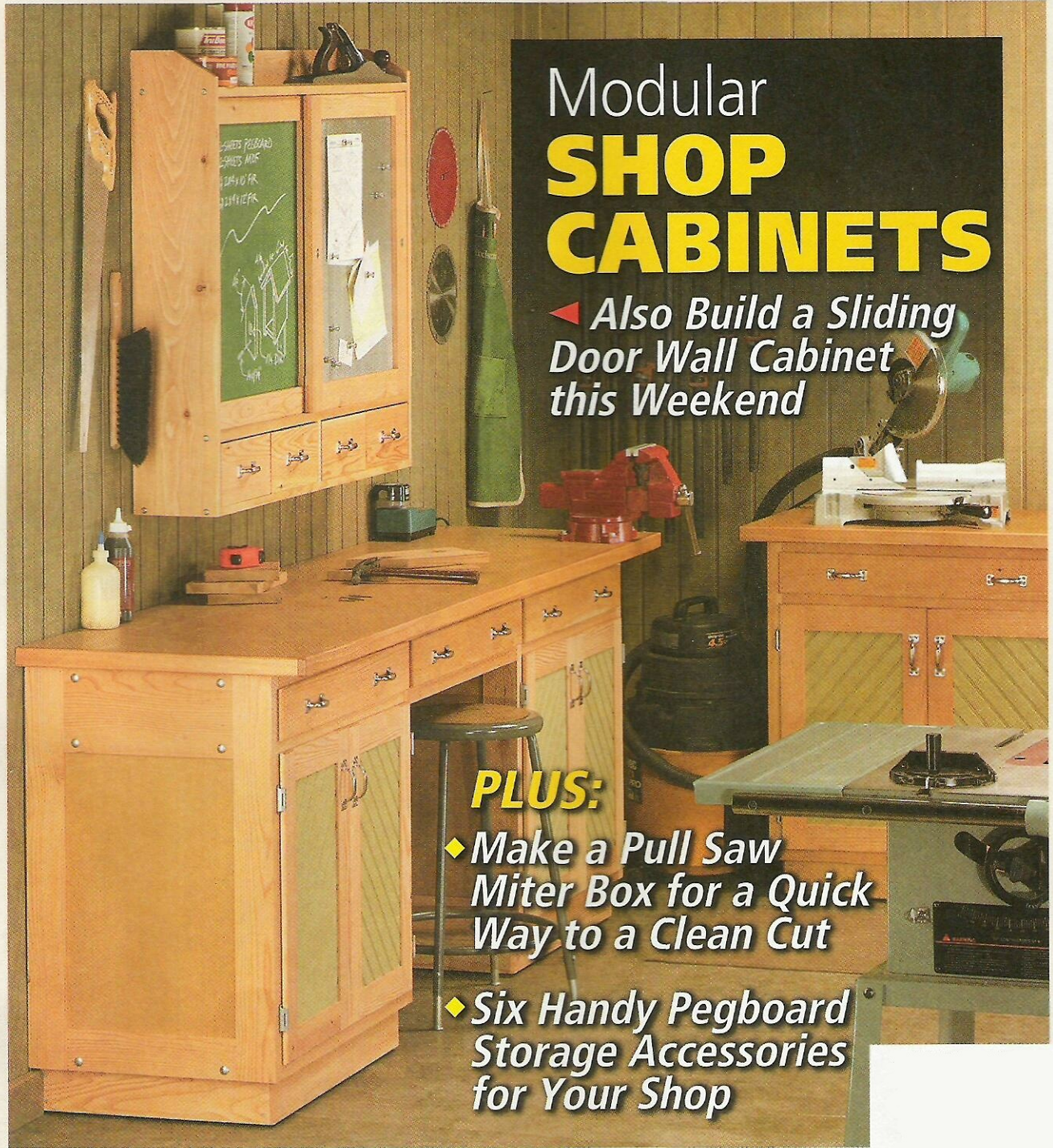

Modular **SHOP CABINETS**

◀ *Also Build a Sliding
Door Wall Cabinet
this Weekend*

PLUS:

- ◆ *Make a Pull Saw
Miter Box for a Quick
Way to a Clean Cut*
- ◆ *Six Handy Pegboard
Storage Accessories
for Your Shop*



ShopNotes®

Issue 59

September 2001

PUBLISHER Donald B. Peschke

EDITOR Terry J. Strohman

ASSOCIATE EDITORS Bryan Nelson

Vincent Ancona

ART DIRECTOR Cary Christensen

SR. GRAPHIC DESIGNER Kurt Schultz

SENIOR ILLUSTRATORS Roger Reiland

Mark Higdon

CREATIVE RESOURCES

Creative Director: Ted Kralioek • *Project Developer:* Ken Munkel
• *Project Designers:* Chris Fitch, Craig Iseke • *Shop Craftsmen:*
Steve Curtis, Steve Johnson • *Senior Photographer:* Crayola
England

SPECIAL PUBLICATIONS

Corp. V.P.: Douglas L. Hicks • *Art Director:* Douglas A. Flint • *Sr.*
Graphic Designer: Chris Glowacki • *Graphic Designer:* Vu
Nguyen • *Associate Editor:* Craig Ruegsegger • *Asst. Editors:*
Joel A. Hess, Joseph E. Irwin

CIRCULATION

Subscriber Services Director: Sandy Baum • *New Business Dir.:*
Wayde J. Klingbeil • *Circulation Marketing Analyst:* Kris
Schlemmer • *Assoc. Circ. Marketing Analyst:* Paula DeMatteis •
Renewal Manager: Paige Rogers • *Sr. Graphic Designers:* Mark
Hayes, Robin Friend • *Billing & Collections Mgr.:* Rebecca
Cunningham • *Multimedia Promotion Mgr.:* Rick Junkins •
Promotion Analyst: Patrick Walsh

CORPORATE SERVICES

V.P. of Finance: Mary Scheve • *Controller:* Robin Hutchinson • *Sr.*
Accountant: Laura Thomas • *Accounts Payable:* Mary Schultz •
Accounts Receivable: Margo Petrus • *Prod. Dir.:* George Chmielarz
• *Electronic Pub. Dir.:* Douglas M. Lidster • *Network Admin.:* Cris
Schwanebeck • *Pre-Press Image Specialists:* Troy Clark, Minnette
Johnson • *Office Mgr.:* Noelle Carroll • *New Media Mgr.:* Gordon C.
Gaippe • *Multimedia Art Dir.:* Eugene Pedersen • *Technology*
Analyst: Carol Schoeppler • *Web Content Mgrs.:* David Briggs, Sue
M. Moe • *Web Designer:* Kara Blessing • *Professional Dev. Dir.:*
Michal Sigel • *H. R. Assistant:* Kirsten Koele • *Administrative*
Asst.: Evy Beneda • *Receptionist:* Jeanne Johnson • *Mail Room*
Clerk: Lou Webber

MAIL ORDER

Operations Director: Bob Baker • *Customer Service Mgr.:* Jennie
Enos • *Warehouse Supr.:* Nancy Johnson • *Buyer:* Linda Jones •
Admin. Asst.: Nancy Downey • *Tech. Rep.:* John Audette • *Cust.*
Serv. Reps.: Anna Cox, Tammy Truckenbrod, Deborah Rich,
April Revell, Valerie Riley, Linda Stepp, Eddie Arthur •
Warehouse: Sylvia Carey, Dan Spidle, Sheryl Knox, Al Voigt

WOODSMITH STORE

Manager: Dave Larson • *Asst. Mgr.:* Tim Thelen • *Sales Staff:*
Wendell Stone, Jim Barnett, Kathy Smith, Larry Morrison,
Harold Cashman, Gregory Kauzlarich, Mark Johnson, Joe Kucera
• *Office Manager:* Vicki Edwards

ShopNotes® (ISSN 1062-9696) is published bimonthly (Jan., March,
May, July, Sept., Nov.) by August Home Publishing, 2200 Grand,
Des Moines, IA 50312.

ShopNotes® is a registered trademark of August Home Publishing
©Copyright 2001 by August Home Publishing. All rights reserved.
Subscriptions: Single copy: \$4.95. One year subscription (6 issues),
\$27.95. Canada/International add \$10 per year; U.S. funds.

Periodicals Postage Paid at Des Moines, IA and at additional mail-
ing offices.

Postmaster: Send change of address to ShopNotes, P.O. Box 37103,
Boone, IA 50037-2103.

Subscription Questions? Write to: ShopNotes Customer Service,
P.O. Box 842, Des Moines, IA 50304-9961. Or call 1-800-333-5854,
8:00 am to 5:00 pm, Central Time, weekdays. FAX 515-283-0447

E-Mail: ShopNotes@shopnotes.com
Internet: http://www.shopnotes.com

PRINTED IN U.S.A.

EDITOR'S NOTE

Cutoffs

One project request we get quite often is for storage cabinets. That makes sense really. No matter what size your shop is, it seems everyone could always use a bit more storage. So for this issue, we decided to design some shop cabinets. That was the easy part.

The trouble was figuring out what shop to design them for. A garage wall? A basement corner? No two shops are the exactly the same size — or have the same layout. So how do you design cabinets that will fit in any size shop and into any layout?

Modular Design – Our solution was to design a modular cabinet that could be built as one or more stand-alone units, or as several sections that end up interconnected. So you can build a row of cabinets that fill up an entire wall, or wrap them around a corner. It is entirely up to you.

Easy to Build – I haven't got to the best part yet. As versatile as this cabinet design is, the project isn't at all

complicated to build. Each cabinet is made up of three horizontal frames and a couple of side assemblies. To keep things simple, these frames and assemblies are held together with stub tenon and groove joinery. And it's all identical, so it can be cut at the same time with a single setup on the table saw. Once all the frames and side assemblies are glued up, the final step is just a matter of bolting everything together.

This bolt-together feature has another benefit as well. You can easily reconfigure or add to the cabinets at a later date. In fact, we're already planning on adding more to the ones installed in our shop.

Wall Cabinet – By the way, if the floor space in your shop is already "spoken for," we're also featuring a cabinet that mounts on a wall. This project has easy-to-build sliding doors and a pegboard back. Plus, there's some handy pegboard accessories for organizing your hand tools.

Terry

Be included, as a part of the Woodworking Shop Tours

On the Web

Visit other ShopNotes subscribers' workshops and see photos of the shop projects they've built. It's all online at Woodworking Shop Tours on the ShopNotes web site:

www.ShopNotes.com

We want you to be part of our shop tours! To submit photos of your favorite ShopNotes projects or views of your shop, just follow the instructions you'll find on our web site.

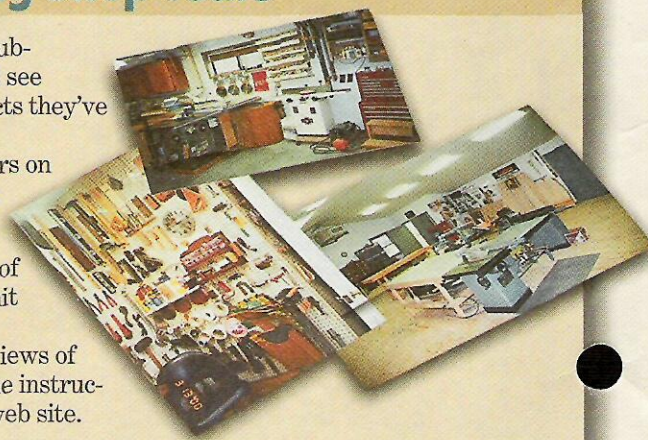

Contents

Features

Modular Shop Cabinets _____ 6

These cabinets are the ideal storage solution for any shop. Constructed with framing lumber, the modular design allows you to configure them to match the space in your shop.

Two Favorite Pull Saws _____ 16

If you've never used a pull saw, you're in for a treat. They cut quickly and cleanly, with little effort. Here's a look at a couple of our favorite types of pull saws.

Pull Saw Miter Box _____ 18

If you're tired of splintering delicate moldings and small pieces with your power miter saw, take a look at this solution. This shop-made miter box allows you to make quick, clean cuts using a hand saw.

Sliding-Door Wall Cabinet _____ 22

Make better use of your wall space with this clever cabinet. Sure it has lots of storage. But the sliding doors also double as a handy chalkboard and a spot for hanging up plans or notes.

Pegboard Tool Holders _____ 28

Pegboard can be found in just about every shop. But these tool holders make your pegboard work harder by organizing the wall space into versatile, customized tool storage.

Cutting Perfect Half Laps _____ 30

Half laps offer an ideal combination of strength and speed. Here are some step-by-step instructions to help ensure your success the next time you use this joint on a project.

Departments

Readers' Tips _____ 4

Shop-tested tips to solve common woodworking problems.

Sources _____ 31

Mail-order sources and supplies to help you build the projects featured in this issue.



Shop Cabinets page 6



Pull Saws page 16

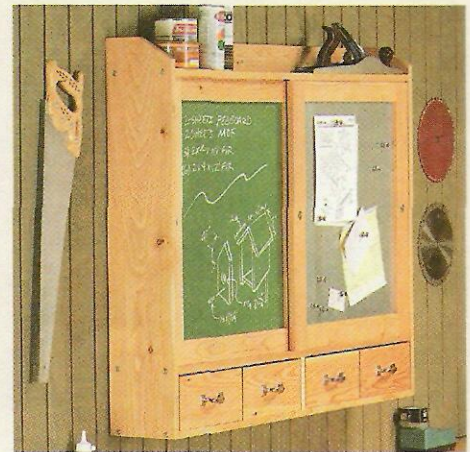

Wall Cabinet page 22



Pegboard Tool Holders page 28

Readers' Tips

Glue Bottle Tote

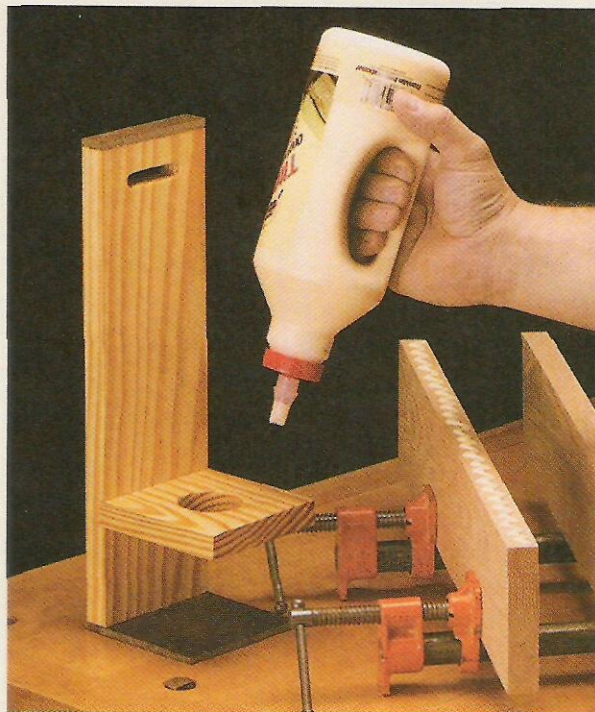

■ When it comes to gluing up a project, I can never seem to remember where I left the glue bottle the last time I used it. And once I find the glue bottle, I'm forever shaking it and pounding on it as if it were a bottle of ketchup, trying to get the glue to come out.

My solution was to make this simple glue bottle tote. It hangs on the wall and holds the glue bottle in an inverted position so that it's ready to go at a moment's notice. And the nice thing is that you can lift the glue bottle — tote and all — off the wall and carry it to wherever you are working.

The tote is quite basic in construction. It can be made out of a few small scraps, see drawing at left. The back plate and shelf are cut from $\frac{3}{4}$ "-thick stock. (I used pine.) A hole is drilled in the shelf to hold the glue bottle, and a dado is cut in the back plate to hold the shelf.

The bottom is just a piece of $\frac{1}{4}$ " hardboard, glued and screwed to the end of the back plate. It allows the tote to stand up on your bench and catches any drops of glue. Another small strip of hardboard is



glued to the top of the back plate for added reinforcement.

The hanger is a block of $\frac{3}{4}$ " stock and a hardboard tab glued and screwed together and then mounted to the wall. A slot cut near the top of the tote allows you to slip it over the hanger tab.

*David Schmetterling
Missoula, Montana*

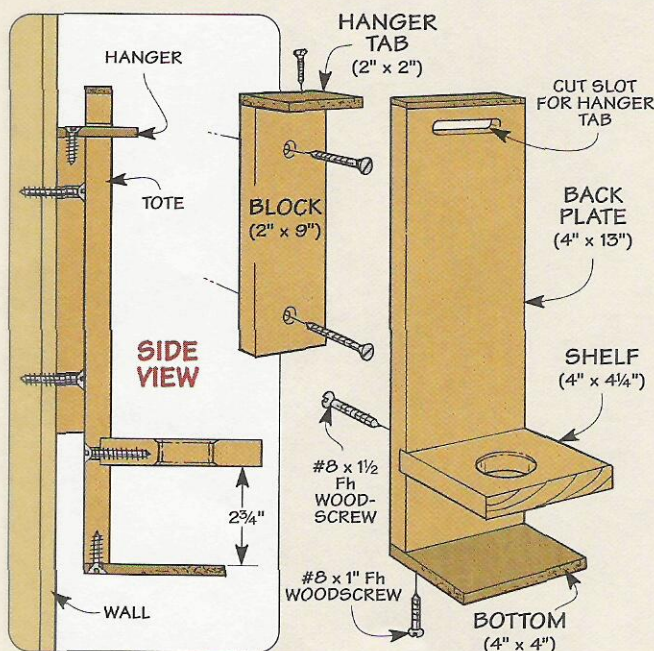

Quick Tips

Free Tips ON THE WEB

Get more wood-working tips free.

Visit us on the Web at ShopNotes.com

Sign up to receive a free shop tip by e-mail every week.

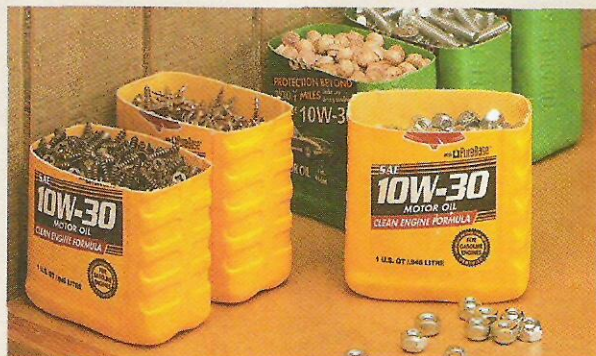

▲ For inexpensive storage bins for small parts, **Roland Blais**, of Newport, VT, cuts the tops off empty motor oil containers and cleans them out.

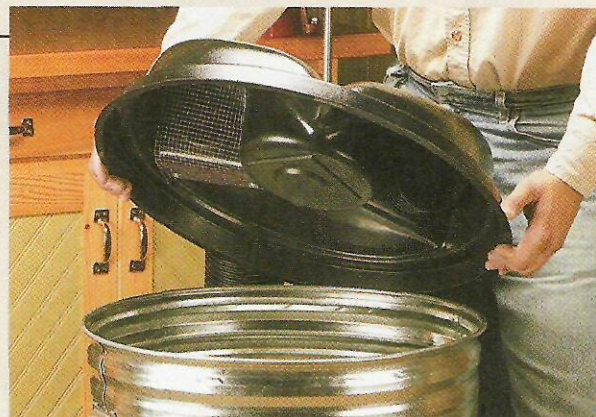

▲ To prevent debris from getting past his cyclone separator, **Zac Reicher**, of West Lafayette, IN, attaches a piece of hardware cloth (screen) to the exhaust port.

Recessed Handles

Recently I made several shallow, stacking boxes for storing hardware and small items in my shop. I wanted to be able to pick up these boxes and move them around easily, but I didn't want to have any handles sticking out of the sides. So I came up with a method for making my own "recessed" handles using a table saw and a stack dado head cutter.

In order to do this safely, I used the

following procedure. First, I raised the dado blade to the depth that I wanted the recesses to be. Then I drew a centerline on the table saw to help me align the box with the dado head, as shown in Figure 1.

After positioning the rip fence, I then lowered the dado head, counting the number of turns it took to lower the blade below the surface of the table. Then with the box

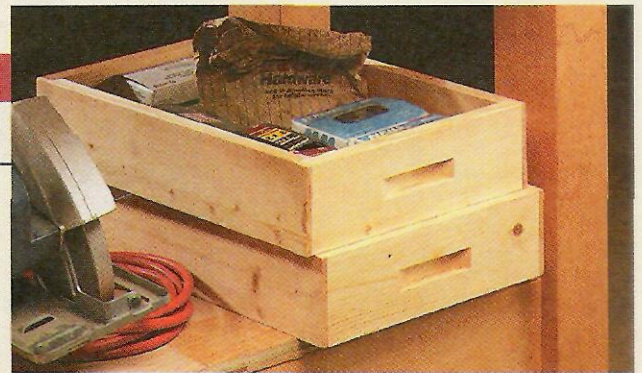

clamped in place, I turned on the saw and raised the dado head the same number of turns, see Figure 2.

*Dale Hodges
Geneva, Florida*

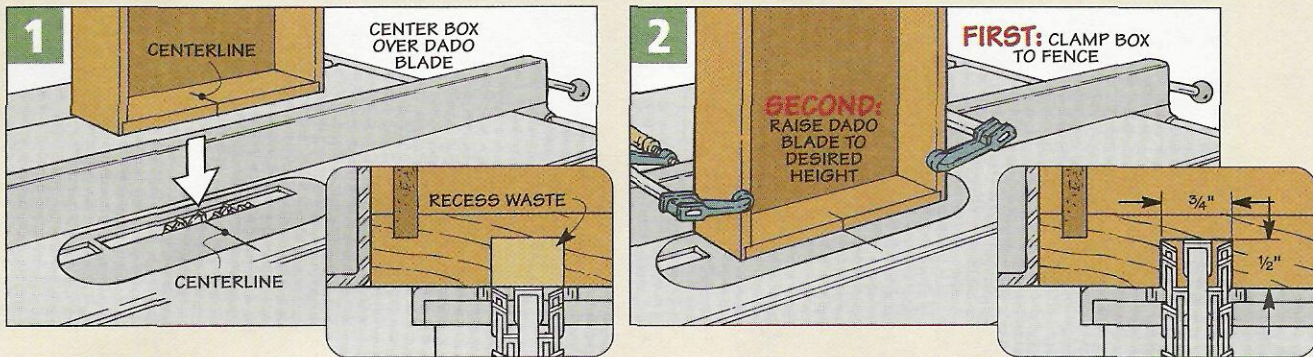

Jig Hanger System

Over the years, I've made a lot of jigs for use in my shop. The trouble is that because of their size and shape, these jigs are often difficult to store. So I came up with an adjustable hanging system that allows me to hang them on the wall.

This system is basically just a wood rail that is attached to the wall. Individual pegs are slid along the rail and can be positioned wherever needed, see photo at right.

The rail is nothing more than a

piece of 3/4"-thick stock with a 45° bevel cut along the top edge, see drawing below. It's screwed to the wall at a convenient height.

The pegs are just short (6") lengths of 3/4"-dia. hardwood dowel stock. They are mounted in blocks that slide along the rail. Each block is made up of three pieces — a main block and two cleats. The upper cleat is beveled to lock in place with the rail. And the lower cleat is sized to provide a small clearance gap below

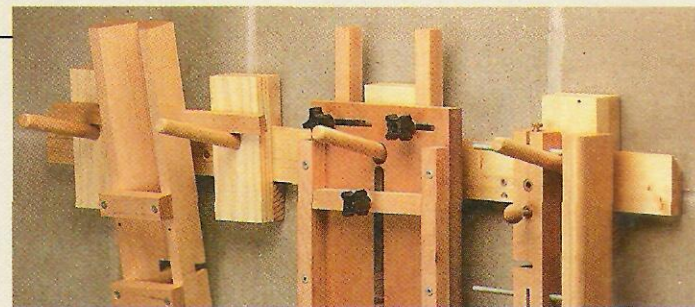

the rail. This way, you can easily reposition the pegs by sliding them to where you need them along the rail.

*Jerry Brightbill
Tonasket, Washington*

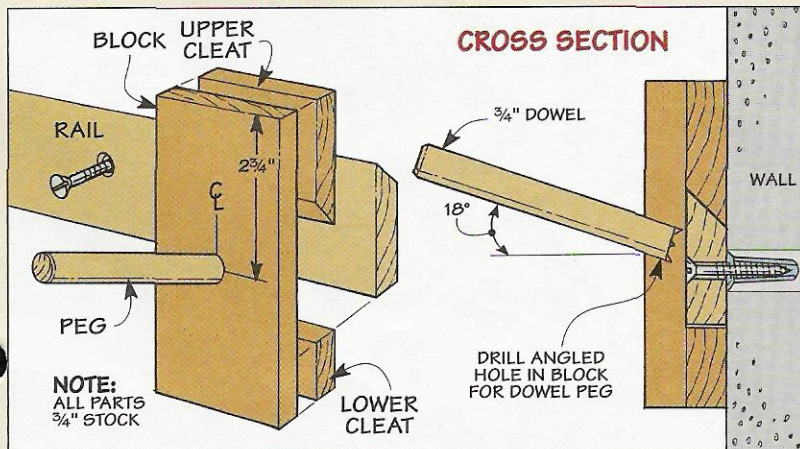

Send in Your Shop Tips

If you have a unique shop tip, we'd like to consider featuring it in one or more of our print or electronic publications.

We'll pay up to \$200 for a tip we publish. Just write down the tip and mail it to *ShopNotes*, Attn.: Readers' Tips, 2200 Grand Ave., Des Moines, IA 50312. Or FAX it to 515-282-6741, or send us an e-mail at shopnotes@shopnotes.com. Please include your name, address and daytime phone number in case we have any questions.



Modular Shop Cabinets

Customize the storage space in your shop by building these sturdy shop cabinets.

Take a look around your shop for a minute. How are you fixed when it comes to storage? If you're like a lot of woodworkers, chances are that you could use more storage space. But the key is to find a storage "system" that works in *your* shop. And that can be a real challenge, since every shop is laid out differently and has a different amount of space available.

Modular Design – That's what makes the shop cabinets pictured above so practical. They're modular in design, so you can build as many units as you like to fit the size and layout of your shop. (See a couple of the possibilities in the photos below.) And the cabinets also

incorporate several features so that you can customize them to make the most of the storage space they offer, as shown in the two photos below.

Strength – But flexibility isn't the only thing these cabinets have going for them. Take a look at the Exploded View drawing on the opposite page, and you'll see that the cabinets are built out of a beefy framework of Douglas fir ("two-by" stock). And the top is made up of a double-thick layer of medium-density fiberboard (MDF). So there's no question that they're strong enough to stand up to the daily abuse of a shop environment. And they won't cost an arm and a leg to build either.



◀ **Expandable.** These shop cabinets are built in individual sections. The sections bolt together to create a long cabinet and a large work surface.



▲ **Drawers and Trays.** Removable dividers organize the contents of the drawer, see top photo above. And a handy, slide-out tray provides convenient access for small tool storage, see bottom photo.

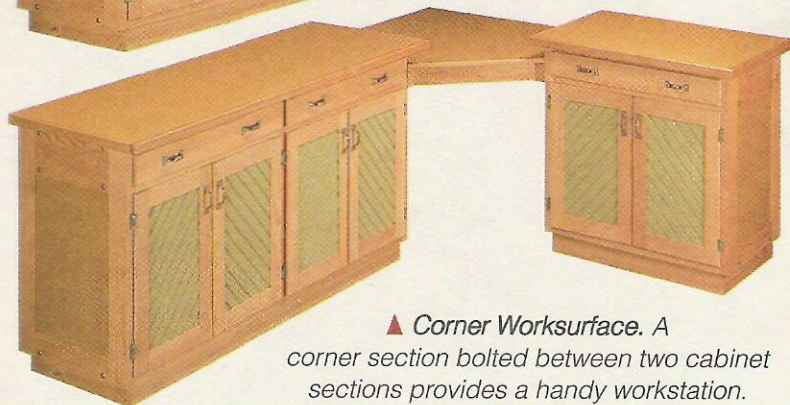

▲ **Corner Worksurface.** A corner section bolted between two cabinet sections provides a handy workstation.

Cutting Diagram ON THE WEB

To get a **free** cutting diagram for this project:
Visit us on the Web at
ShopNotes.com

Or send a stamped, self-addressed envelope to:
ShopNotes Cutting Diagrams
Shop Cabinets
2200 Grand Avenue
Des Moines, Iowa 50312

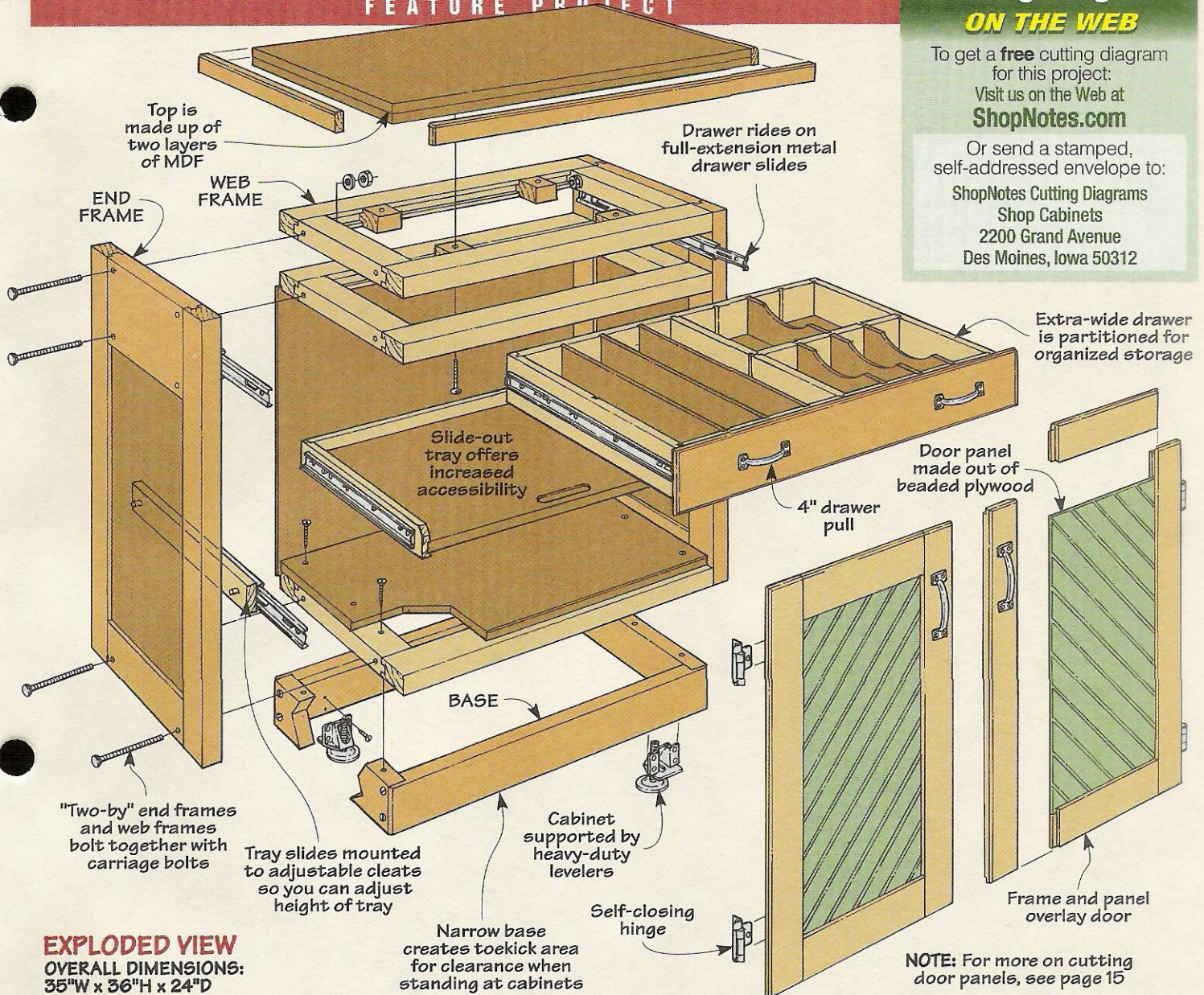

EXPLODED VIEW
OVERALL DIMENSIONS:
35"W x 36"H x 24"D

NOTE: For more on cutting door panels, see page 15

Materials (Single Unit)

Case Assembly

A End Frame Stiles (4)	1 1/2 x 3 1/4 - 31
B Upper End Rails (2)	1 1/2 x 6 1/2 - 15
C Lower End Rails (2)	1 1/2 x 3 1/4 - 15
D Web Frame Rails (6)	1 1/2 x 2 1/2 - 15
E Web Frame Stiles (6)	1 1/2 x 3 1/4 - 29
F End Frame Panels (2)	15 x 22 1/4 - 3/4 MDF
G Back (1)	23 3/4 x 29 3/4 - 1/4 Hdbd.

Top

H Top Panels (2)	23 1/4 x 33 1/2 - 3/4 MDF
I Top Edging (1)	3 1/4 x 1 1/2 - 7 lin. ft.
J Mounting Blocks (4)	1 1/2 x 2 1/2 - 2 1/2

Base

K Base Front/Back (2)	1 1/2 x 3 1/2 - 30
L Base Sides (2)	1 1/2 x 3 1/2 - 19
M Bottom Shelf (1)	19 3/4 x 29 - 3/4 MDF

Drawer

N Drawer Front/Back (2)	3 1/4 x 3 1/4 - 27
O Drawer Sides (2)	3 1/4 x 3 1/4 - 19 3/4
P Drawer Bottom (1)	18 3/4 x 27 - 1/4 Hdbd.
Q Drawer False Front (1)	3 1/4 x 4 - 29 1/2
R Center Divider (1)	3 1/4 x 2 3/4 - 18 3/4
S Cross Divider (1)	3 1/4 x 2 3/4 - 13 3/8
T Long Dividers (3)	2 3/4 x 18 3/4 - 1/4 Hdbd.
U Short Dividers (6)	2 3/4 x 9 1/4 - 1/4 Hdbd.

Tray

V Tray Panel (1)	19 3/8 x 25 3/4 - 3/4 MDF
W Tray Edging (1)	3 1/4 x 2 - 6 lin. ft.
X Tray Cleats (2)	3 1/4 x 2 - 19 3/4

Door

Y Door Rails (4)	3 1/4 x 2 1/2 - 10 1/2
Z Door Stiles (4)	3 1/4 x 2 1/2 - 23 1/2
AA Door Panels (2)	10 1/2 x 19 1/4 - 1/4 Ply.

Hardware

- (12) 5/16" x 4 1/2" Carriage Bolts
- (12) 5/16" Flat Washers
- (12) 5/16" Hex Nuts
- (12) #6 x 1" Fh Woodscrews
- (12) #8 x 2 1/2" Fh Woodscrews
- (4) #8 x 2 1/2" Fh Sheet Metal Screws
- (4) Levelers
- (24) #10 x 5/4" Ph Sheet Metal Screws
- (14) #8 x 1 1/4" Fh Woodscrews
- (8) #6 x 1 1/2" Fh Woodscrews
- (2) 18" Full-Extension Drawer Slides
- (2) 20" Full-Extension Drawer Slides
- (4) 4" Drawer Pulls (w/screws)
- (4) Self-Closing, 3/8" Offset Hinges (w/screws)

NOTE: With the exception of the levelers (see page 31), the hardware used in this project is commonly available at home centers or hardware stores.

Case

These shop cabinets are made up of individual sections which can be bolted together into any configuration you choose. All you have to do is decide how many sections you'll need.

But what's really nice about the design is that the joinery has been planned out so that you don't have to repeat a bunch of machine setups. Whether you are making one section or a dozen, the construction should go quickly.

If you take a look at Figure 1, you'll see that the case of each cabinet is made up of a couple of end frames bolted to three open "web" frames. To give the cabinets strength, I used 1½"-thick Douglas fir ("two-by") framing lumber for the "skeleton."

Frame Pieces – I started by cutting all the frame pieces for both the end frames and the web frames to size. This includes the *end frame stiles (A)*, *upper end frame rails (B)*, *lower end frame rails (C)*, *web frame rails (D)*, and *web frame stiles (E)*. The dimensions for these pieces are shown in Figure 2.

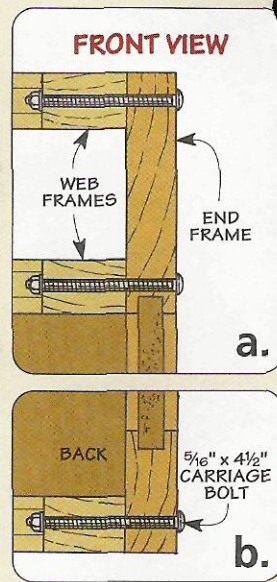
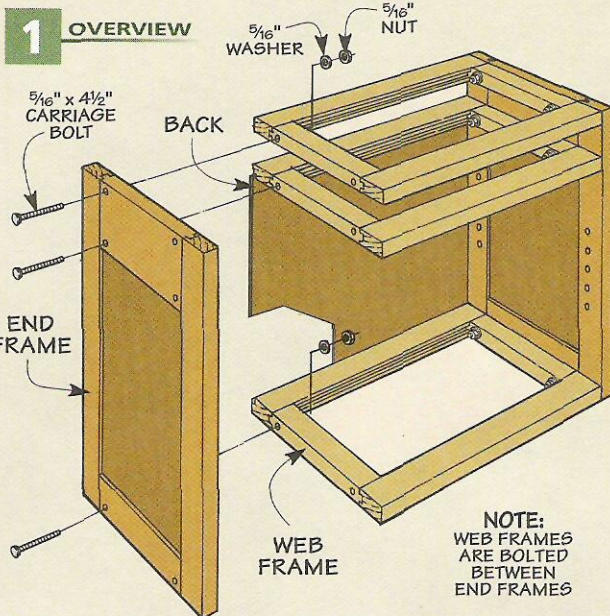

NOTE: WEB FRAMES ARE BOLTED BETWEEN END FRAMES

Grooves – Each end frame will hold a ¾" MDF panel. In Figures 2b and 2c, a centered groove is being cut on all the rails and stiles of the end frames (A, B, C) to match the thickness of the MDF used for the panels. To center the groove, cut it in two passes, flipping the workpiece end-for-end between passes.

Although the web frames won't be holding any panels, I used the same setup to cut identical grooves on the inside edge of all the web frame stiles (E). These will receive

the stub tenons that are cut on the web frame rails next.

Stub Tenons – Stub tenons and grooves are used to assemble the rails and stiles of the end frames and web frames. These stub tenons are sized to fit in the grooves you just cut. You can see how I cut these in Figure 2d. The trick here is to start by cutting the tenon slightly thick, or "fat," then gradually sneak up on the final thickness by raising the blade in small increments until the tenon fits in the groove.

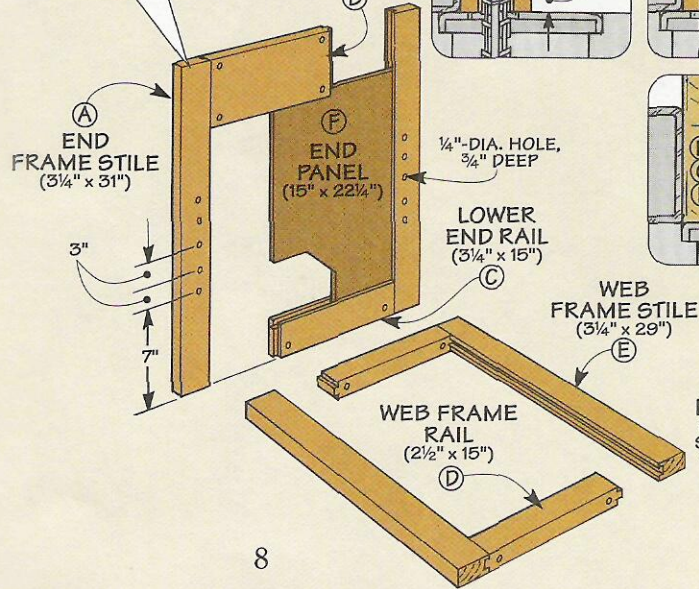
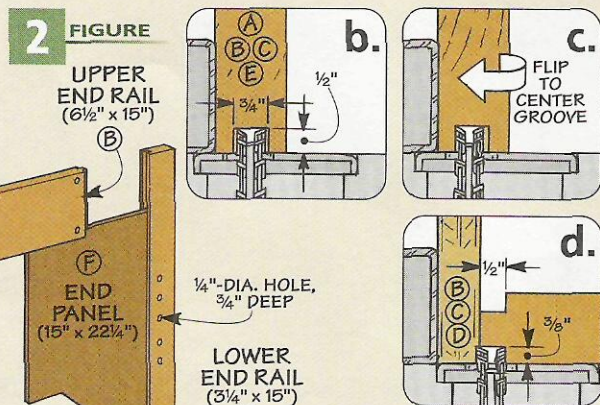
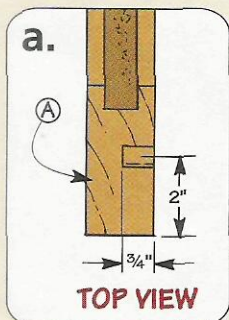

NOTE: ALL RAILS AND STILES ARE 1½" THICK; PANEL IS ¾" MDF

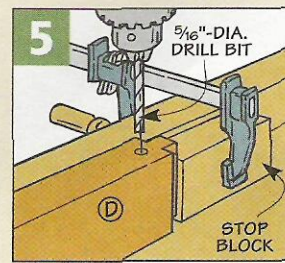
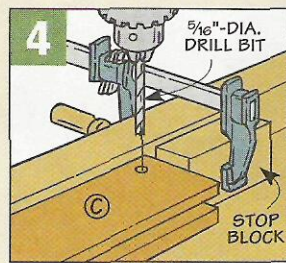
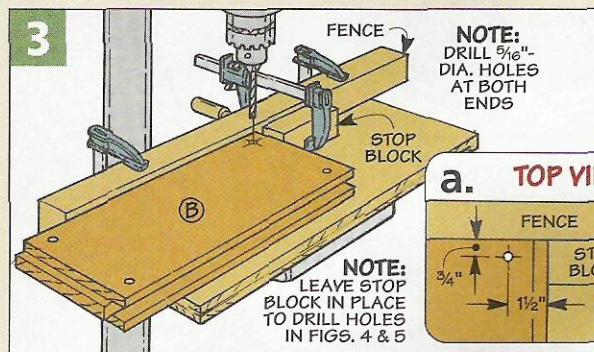

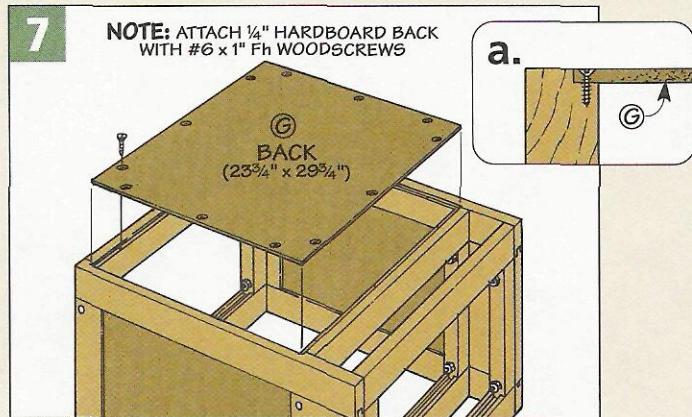
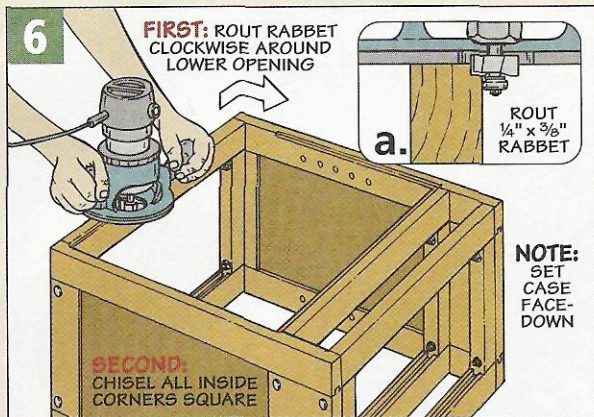

After cutting the tenons and grooves, the next step is to drill some $\frac{5}{16}$ "-dia. holes in the rails for the carriage bolts that will connect the web frames to the end frames. The key to getting the frames to line up when assembling the case is to drill all these holes in the exact same location. In order to do this, I set up a fence with a stop block on my drill press. Once you get the stop block positioned correctly, you can use this same setup to drill holes in the ends of the end frame rails (B, C) and the web frame rails (D), as shown in Figures 3, 4, and 5.

Panels – The web frames can be glued up at this point. But before assembling the end frames, you'll need to cut the panels that fit inside them. The *end panels (F)* are cut from $\frac{3}{4}$ " MDF (Figure 2). Once they are cut to size, the end frames can be glued up around them.

Shelf Pin Holes – Before bolting the end frames and web frames together, some $\frac{1}{4}$ "-dia. holes are drilled on the inside of the end frames (Figures 2 and 2a). These will be used to support the slide-out tray (or optional shelves) that are added to the cabinet later.

After the holes are drilled, the cabinet can be assembled. Carriage bolts, washers, and nuts are all it takes to attach the end frames to the web frames, as shown in Figure 1.

Back – The last thing to add to the case is a back. The *back (G)* is a piece of $\frac{1}{4}$ " hardboard that fits into a rabbeted opening routed on the back of the case (Figure 6). But it doesn't cover the entire back of the case. Instead, it just covers the lower portion. After squaring up the corners of the routed opening with a chisel, the back can be cut to size and screwed in place (Figure 7).

Putting it All Together

The main feature of these cabinets is the fact that they are modular. The individual sections simply bolt together. This allows you to disassemble them if your shop layout changes or if you want to take them with you when you move.

Connecting the sections is a simple procedure. All you have to do is use carriage bolts that are long enough to pass through both web frames and the end frame in between them, as shown in the drawing at right. (I found it helpful to hold the sections together with clamps while installing and tightening the carriage bolts.)

One other thing. If you look at the drawing at the right, you'll notice that there's only one end panel between the two units. So if you're planning on building multiple units, that's one less panel that you'll need to build.

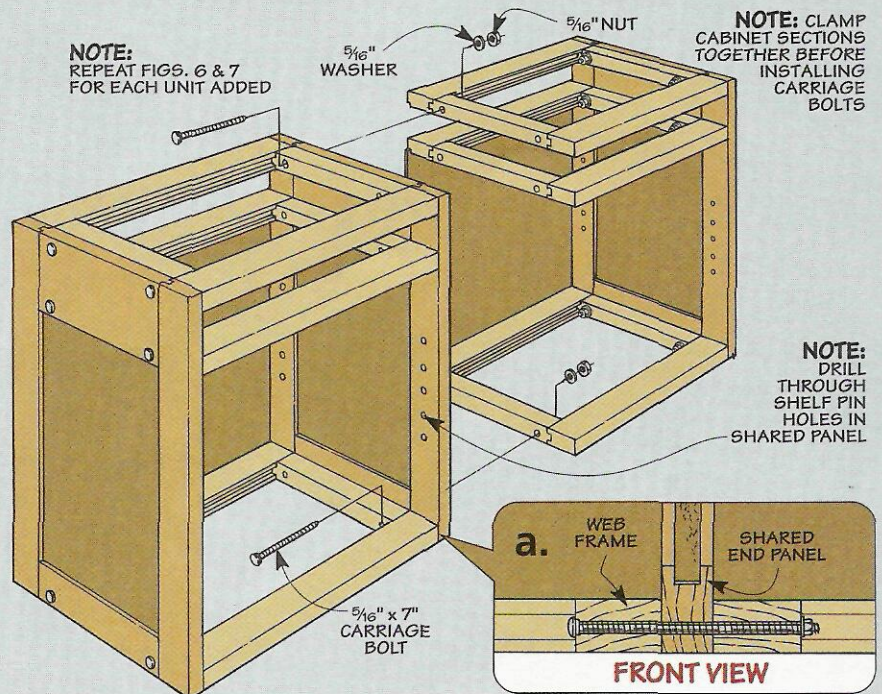

Top & Base

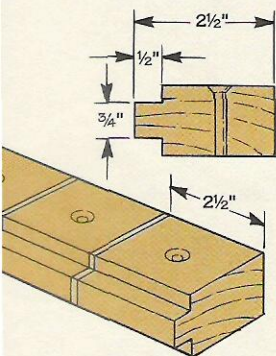

MOUNTING BLOCK DETAIL
(DRILL CENTERED HOLES AFTER CUTTING BLOCKS TO LENGTH)

With the case of the cabinet complete, the next step is to add a base and a top. Here's where you will have to make a decision. Although the cabinets are built in sections, the base and top are not. So you need to decide how you are going to configure the cabinets in your shop so you can size the base and top to fit.

Top - Since these cabinets will be in a shop, it's a pretty safe bet that the top will be used as a workbench from time to time. So the top needs to be both strong and durable. To achieve this, I decided to make the top out of two layers of 3/4"-thick MDF (Figure 8).

Before cutting the MDF, you'll need to determine the size of your top. To do this, first measure the length and depth of the cabinet. The top is sized to overhang the front edge of the cabinet by 3 1/2" and the sides by 1 1/2". It's flush with the back. Figure 10 shows you the

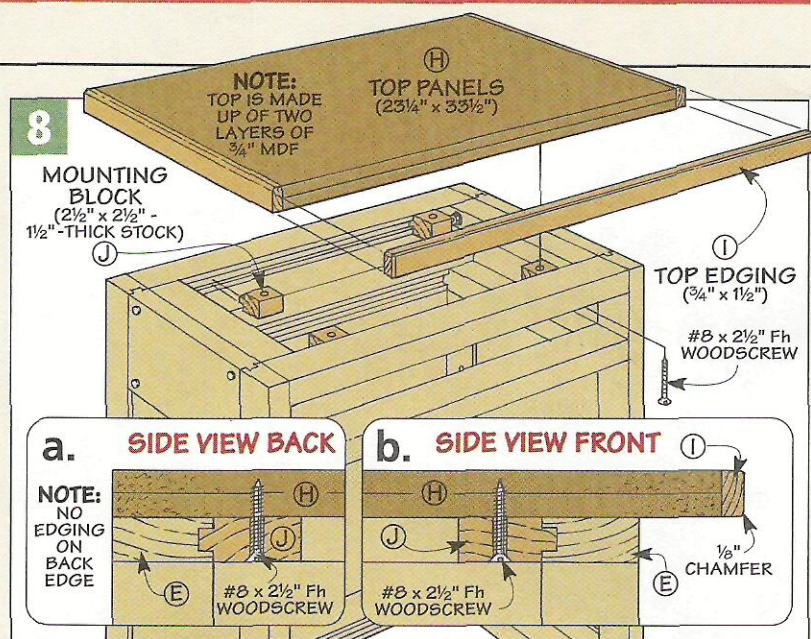

length of the top depending on whether you are building it for one, two, or three cabinet sections.

Once you have determined the overall size for the top, you need to figure the size of the *top panels* (H). To do this, subtract 3/4" from the

overall width and 1 1/2" from the overall length of the top. (This is to allow for the 3/4"-thick edging that will be added later.) Now you can cut the first layer of MDF to exact size. Then cut the second layer about 1/2" longer and wider than the first.

After the two layers are glued together, the oversize layer is trimmed flush with the first layer using a router and flush trim bit. To complete the top, some wood edging (I) is applied to the front and sides and then the edges are chamfered.

To attach the top to the cabinets, I made some simple *mounting blocks* (J) (Figure 8). These are made out of 1 1/2"-thick stock, see drawing in margin. A tongue on the edge of each block fits into the groove in the web frame. Then screws are used to fasten the top to the mounting blocks (Figures 8a and 8b).

Base - Like the top, you'll need to determine the overall size of the base before cutting the pieces to size. Figure 10 shows the length of the base for one, two, or three cabinets, or you can calculate what you'll need for your cabinets. The base should set back 1" from the front and sides of the cabinet.

If you take a look at Figure 9, you'll notice that the base is nothing more than four pieces of 2x material. After cutting two *base front/back*s

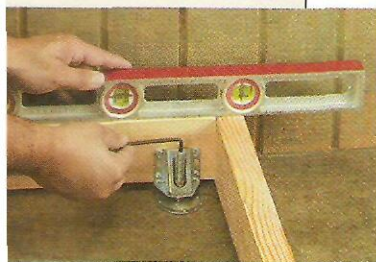
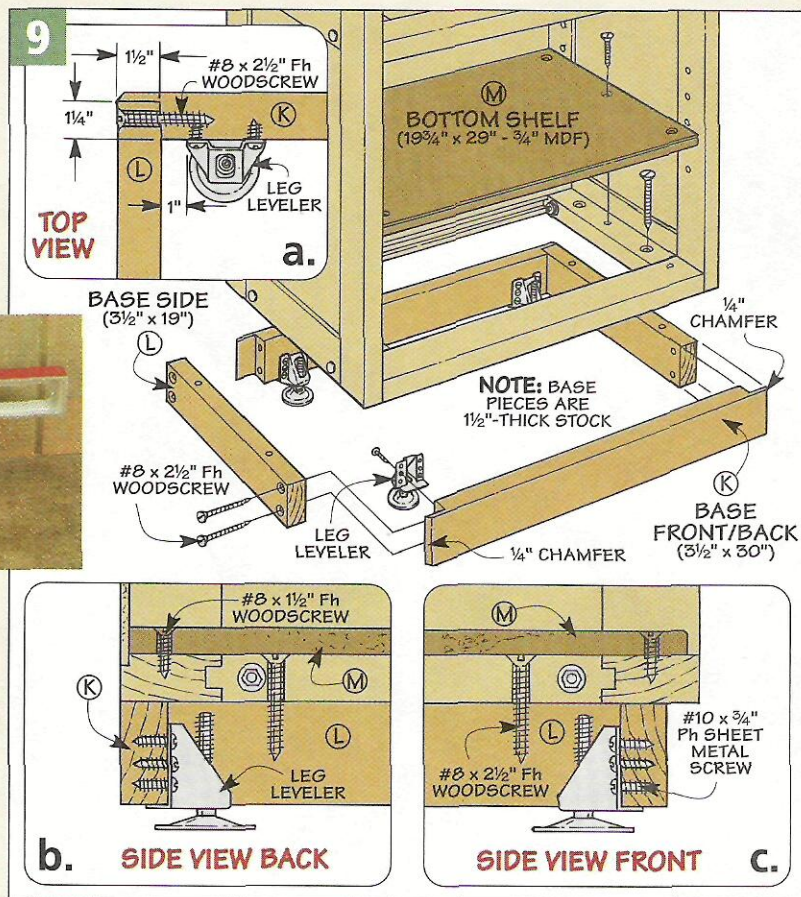

▲ **Level the Base.**
An Allen wrench is all you need to adjust the leg levelers used on the cabinet base.

(K) and two *base sides* (L), you can cut rabbets on the ends of the front and back pieces. Then the pieces are glued and screwed together. Finally, the corners of the base are chamfered (Figure 9a).

The main purpose of the base is to provide a stable, level surface to set the cabinet on. In order to achieve this, an adjustable leveler is attached to each corner of the base. Once these are installed, you can set the base where you want it and level it. Then set the cabinets on top of the base and attach them with screws. Finally, a *bottom shelf* (M) is added to each section of the cabinets, see Figure 9. This is simply screwed in place against the bottom web frame.

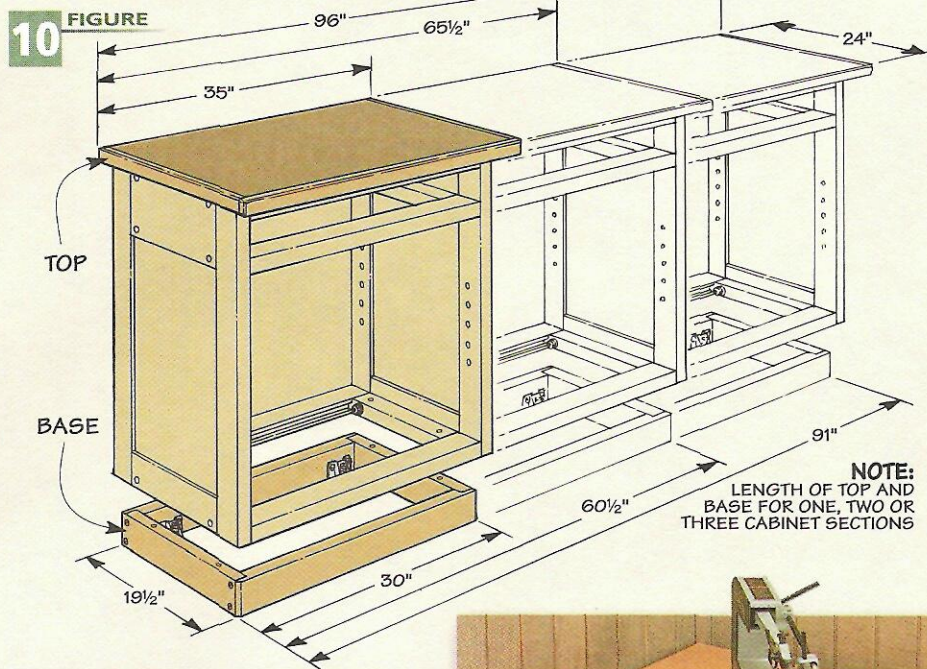

Corner Workstation

So what if you want to build cabinets along two adjoining walls in your shop? Ordinarily, the corner of a room poses a bit of a design challenge, whether it be in a shop or in a kitchen. But in this case, the solution is quite simple. Instead of building a complicated corner unit, the cabinets are joined by a "floating" top that fits in the corner.

Like the tops on the cabinets, the corner top is made out of MDF. But because there isn't a corner cabinet underneath it, you'll need to make a sturdy

frame to support the top. This frame will be bolted to the ends of the cabinets.

As you can see in the drawing below, the frame is constructed from 1 1/2"-thick lumber. It's glued and screwed together. The top is cut from a single layer of 3/4" MDF. (There's no edging.) Then it's just glued down to the top of the frame.

The corner top is bolted between the two cabinets so it sits below the surface of the other counter tops, as shown in detail

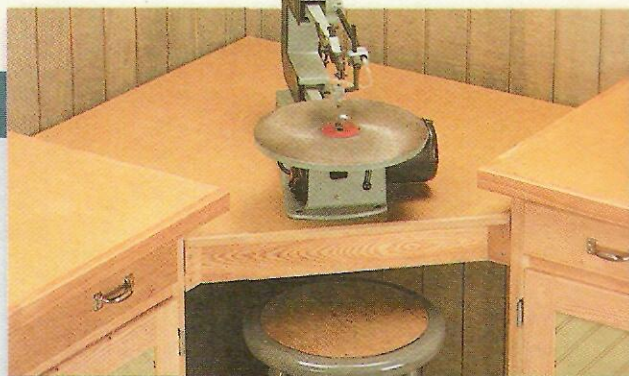

'a.' This puts it at a convenient height to use as a desk or as a workstation for small power tools. And since the space underneath the top is open, you'll be able to get a chair or shop stool underneath the corner top without any problem.

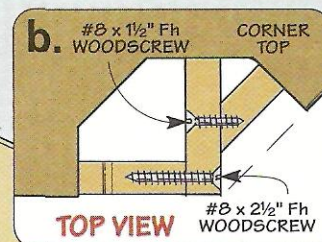
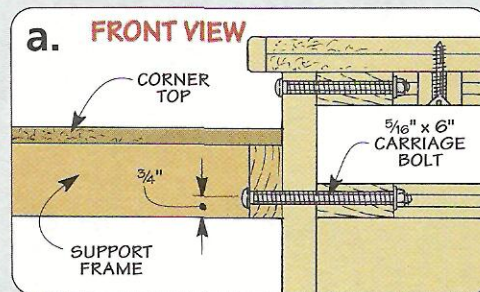
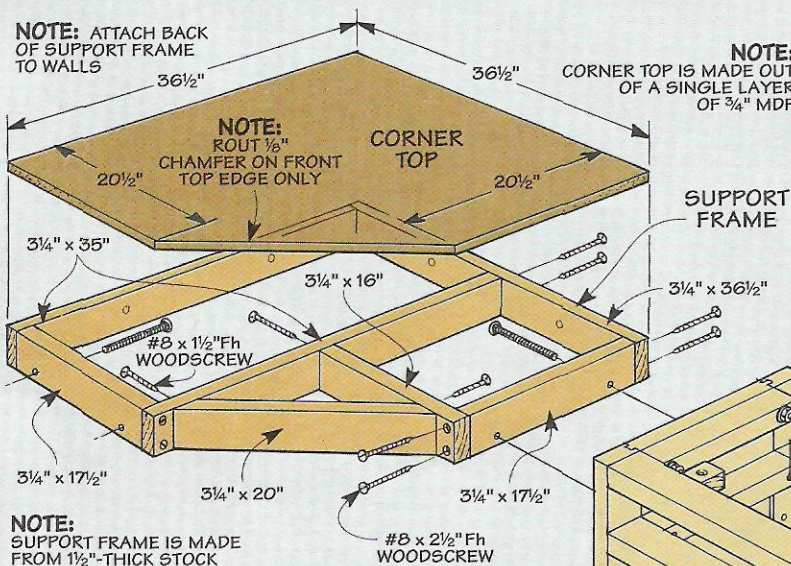

Drawer & Tray

11 OVERVIEW

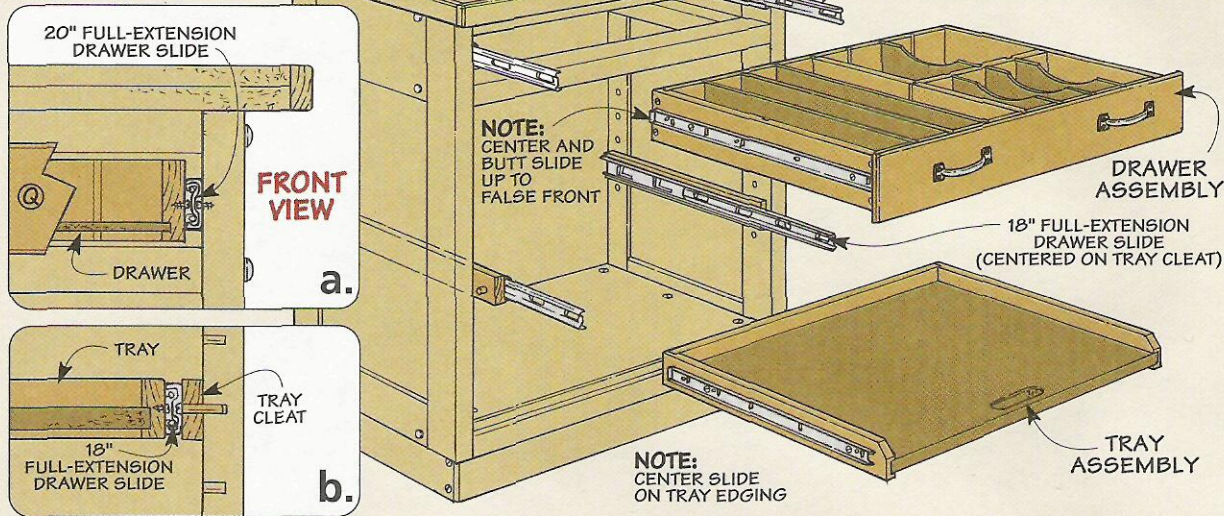

Now that the main carcass of the cabinet is complete, you can move on to building the drawer and the slide-out tray (Figure 11).

Drawer – The drawer is built of $\frac{3}{4}$ "-thick Douglas fir. You can cut the *drawer front/back* (N) and the *drawer sides* (O) to the dimensions shown in Figure 12.

As you can see in Figures 12a and 12b below, the drawer sides are joined to the front and back with a locking rabbet joint.

Before assembling the drawer,

there are a couple more steps to do. First, a groove is cut along the bottom edge of all the drawer pieces to hold a $\frac{1}{4}$ " hardboard drawer bottom. Then, a series of dados is cut along the inside face of the drawer front and back to hold some movable dividers, see Figures 12 and 12b. These dados can be cut on the table saw, using a dado blade and an auxiliary fence on your miter gauge to support the workpiece.

In addition to the dados on the drawer front and back, each drawer

side also receives a centered dado to hold a cross divider. This dado can be seen in Figure 12.

A false front will be added to the drawer after it is assembled and installed in the cabinet. But it's a lot easier to drill the screw holes for attaching the false front at this point, before the drawer is assembled.

Drawer Bottom – After cutting all the dados for the drawer dividers, you can cut the *drawer bottom* (P) to size from $\frac{1}{4}$ " hardboard. Then the drawer can be glued up and the

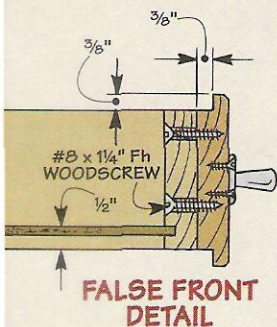

12 FIGURE

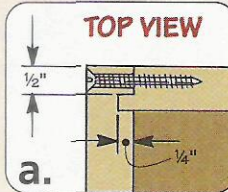
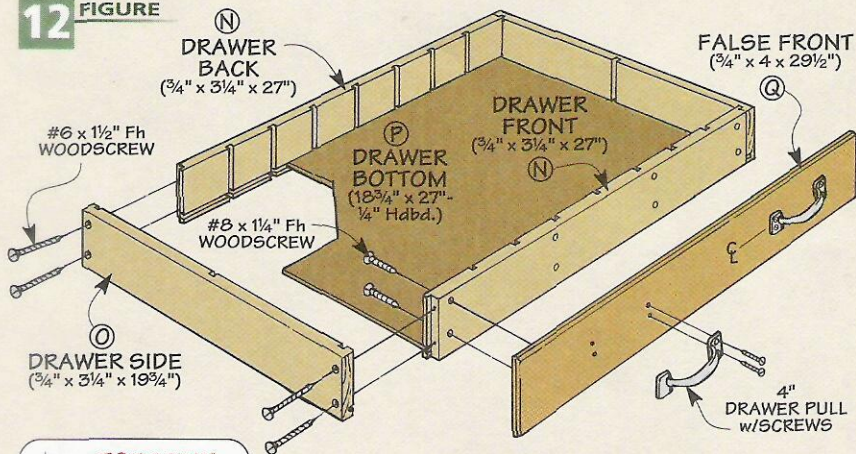

13 FIGURE

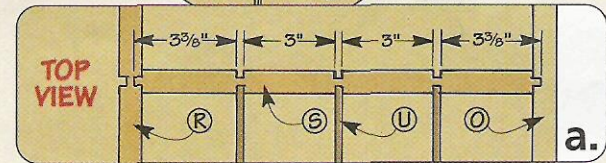
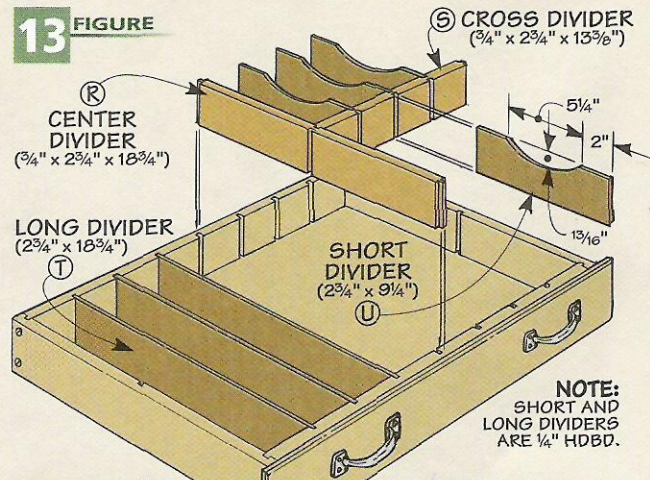

corners reinforced with screws.

After the drawer has been assembled, it can be installed in the cabinet. The drawer rides on a pair of full-extension, metal drawer slides. One half of the slide is mounted to the side of the drawer and the other half is mounted to the inside of the cabinet, like you see in Figure 11.

False Front – Once the drawer is installed in the cabinet, you can make the *false front* (Q). A rabbet is routed around the edge of the false front to create a lip that overlaps the drawer opening. Then a chamfer is routed around the outside edges. Finally, the piece is screwed to the front of the drawer, as shown in the detail drawing in the margin on page 12. A couple of drawer pulls added to the front complete the drawer.

Drawer Dividers – The removable drawer dividers are optional, but they really help to keep items in the drawer organized. There's not much to the dividers, as you can see in Figure 13. And you can customize them and rearrange them in any way to suit your storage needs.

14 FIGURE

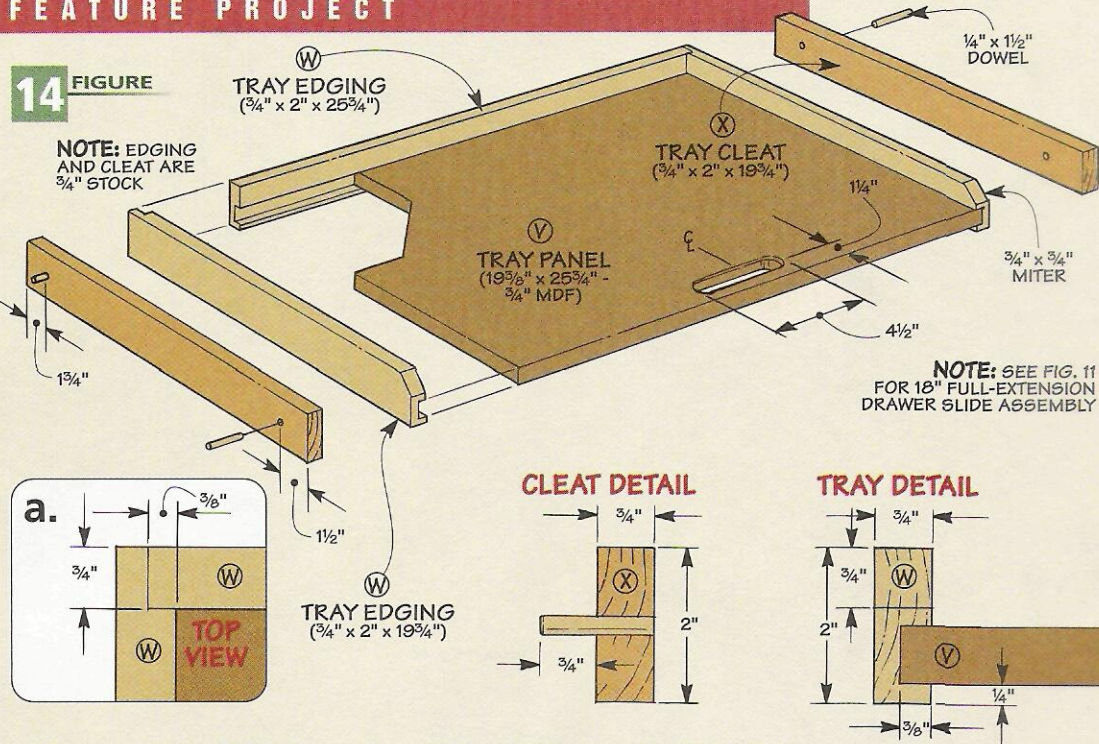

I made a single, 3/4"-thick, *center divider* (R) to divide the drawer into right-hand and left-hand sides. Then I divided the right-hand side again with a *cross divider* (S). Finally, I made up several *long* and *short dividers* (T, U) out of hardboard to further partition the drawer space.

All the dividers simply slide into the dadoes cut in the drawer pieces. (You'll have to cut tongues on the ends of the 3/4"-thick dividers to allow them to fit in the dadoes.)

Tray – The storage compartment below the drawer can be made much more useful by adding the pull-out tray shown in Figure 14. Like the drawer, the tray slides in and out on the same type of full-extension slides.

The *tray panel* (V) is just a piece of 3/4" MDF. An oblong cutout is made near the front of the tray to serve as a handle for pulling the tray out of the cabinet.

Figures 14 and 14a show that the tray is surrounded on three sides by some *tray edging* (W). This edging serves two purposes. First it prevents items stored on the tray from rolling off the back edge. And second, it provides a place to mount the drawer slides.

Tray Cleats – To make it possible to adjust the position of the tray, I didn't mount the drawer slides directly to the cabinet. Instead, I mounted them to a couple of *tray cleats* (X). These can be seen in Figure 14 and the cleat detail drawing. They are just a couple of pieces of wood, with dowels glued in them that allow them to be inserted in the holes in the sides of the cabinet.

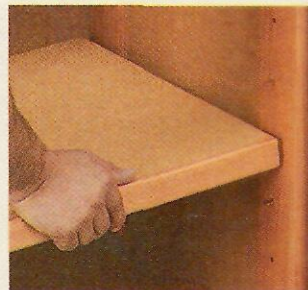

▲ **Optional Shelves.** Instead of the pull-out tray, you can build adjustable shelves for the cabinet. (See the box at left.)

Optional Shelves

If you don't think you need the convenience of a slide-out tray in these cabinets, it's a simple matter to substitute some adjustable shelves instead.

Each shelf is nothing more than a piece of MDF, see the drawing below. In order to strengthen the shelf, a wood

edging strip is added along the front edge. This edging strip is rabbeted and glued to the front of the shelf, as shown in the detail drawing below. Then the edges of the strip are chamfered slightly.

The shelf rests on shelf pins that fit in the holes drilled in the sides of the cabinet.

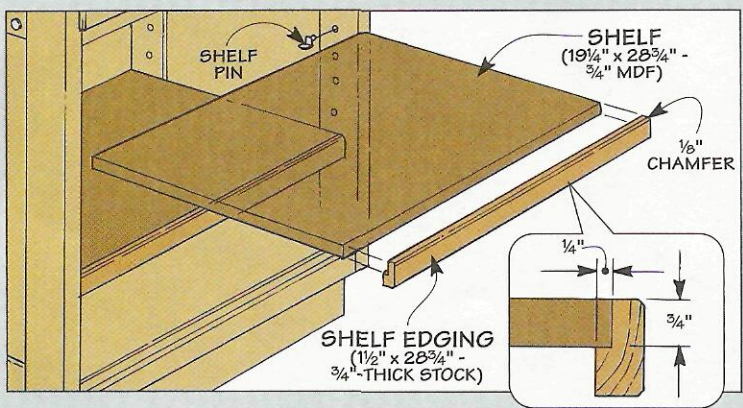

Doors

Panel Options



Diagonal



Vertical

▲ **Panel Options.** To give the doors a different look, you can change the direction the beads run on the panels.

To help keep out dust, the lower section of the cabinet is fitted with a pair of doors (Figure 15). These are overlay doors — they are rabbeted along the outer edges to fit over the case frame. Aside from this, the construction is nothing more than a basic frame and panel.

Like the drawer, the door frames are made from 3/4"-thick stock. You can cut the door rails (Y) and stiles (Z) to size, as shown in Figure 16.

The frame pieces will hold a panel cut from beaded plywood. To hold this panel, a groove is cut along the edge of each door frame piece. I cut this groove in two passes, flipping the workpiece between passes in order to center the groove on the thickness of the stock. This is shown in Figure 16a.

The door rails are joined to the stiles with stub tenons. So the next step is to cut tenons on the ends of the rails to fit in the grooves in the stiles (Figure 16b).

Panels – The door panels (AA) are cut from 1/4" plywood. But the plywood I chose is a little special. It has decorative beads cut along its length to simulate the look of beaded boards that were often used as wain-

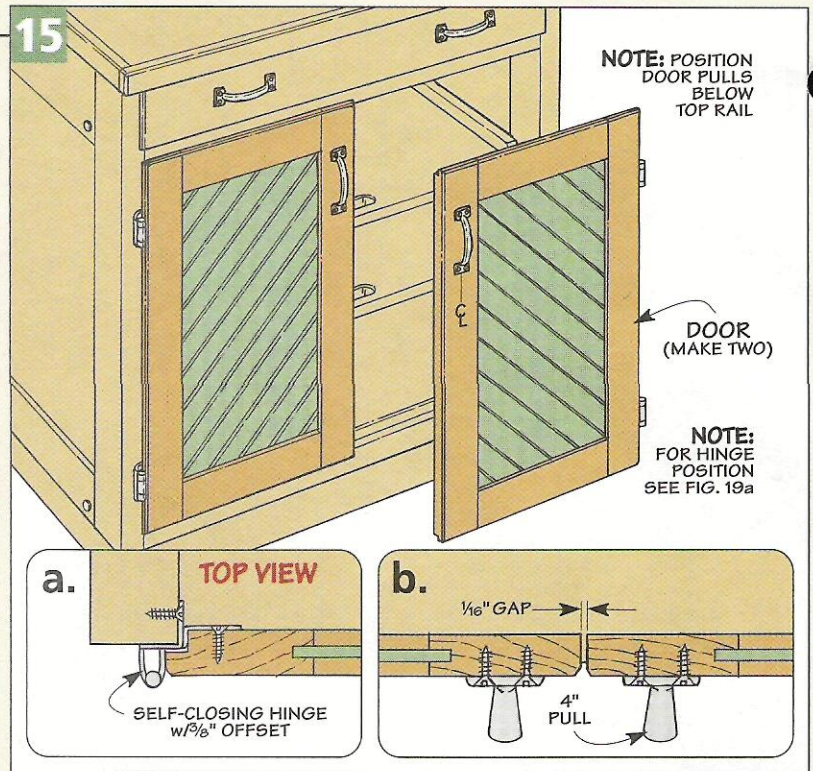

scoting or in the backs of cabinets in the past. The beads offer you a chance to play with the look of the doors. You can cut the panels so the beads run vertically, or you can cut the panels with beads running at an angle, like I did. For more on this, see the photos in the margin at left and the box on the opposite page.

Once the panels have been cut to size, the door frames can be glued up around the panels. (Note: I painted the panels on my cabinet. If you wish to do the same, it's easiest to paint the panels before gluing up the doors.) As you are clamping up the doors, check to make sure that they are both flat and square. If

16 FIGURE

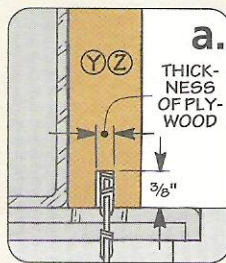
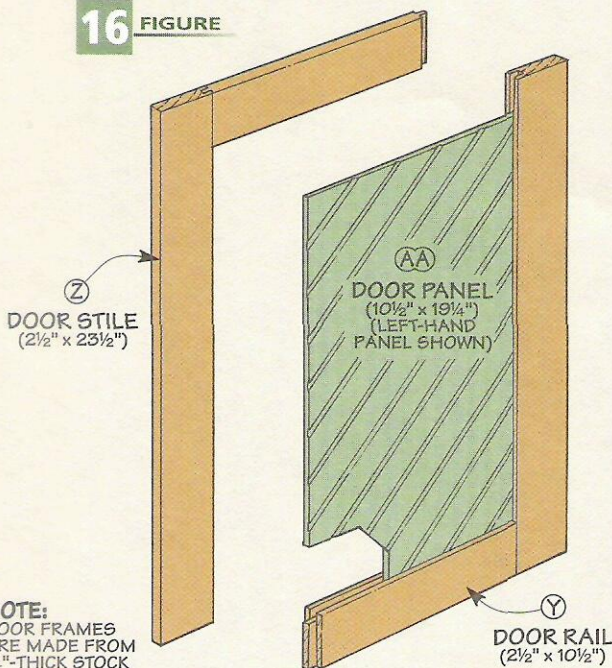

NOTE: DOOR PANEL IS CUT FROM 1/4" BEADED PLYWOOD

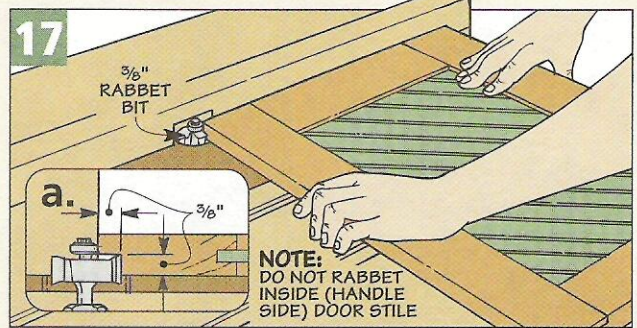
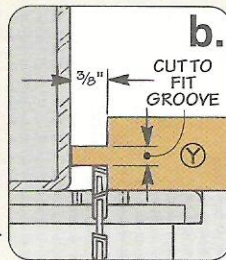

NOTE: DO NOT RABBET INSIDE (HANDLE SIDE) DOOR STILE

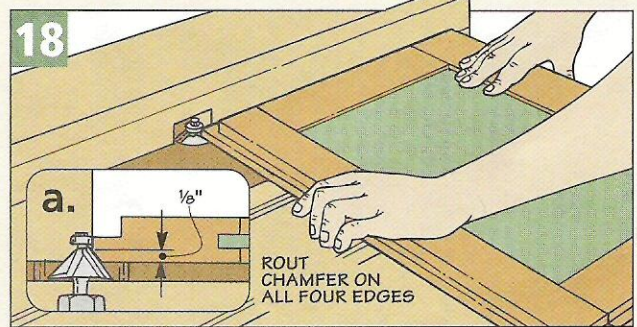

they aren't, you may have to adjust the clamps a little bit.

Rabbets – To create the overlay on the doors, a rabbet is routed on the top, bottom, and outer edge of each door. This is done quite easily on a router table, using a rabbeting bit, as shown in Figure 17.

Chamfers – The last step to complete the doors is to rout a chamfer

along all four edges, just like you see in Figures 18 and 18a. This not only eases the sharp edges of the doors, but it also prevents splintering.

Hardware – The doors are mounted to the cabinet with surface-mounted, self-closing hinges. These are shown in Figures 15a and 19. Then a pull can be added to the front of each door (Figure 15b).

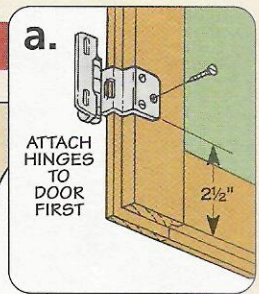
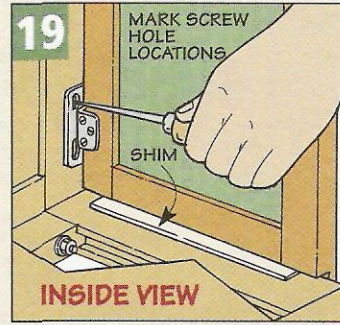

Cutting Diagonal Panels

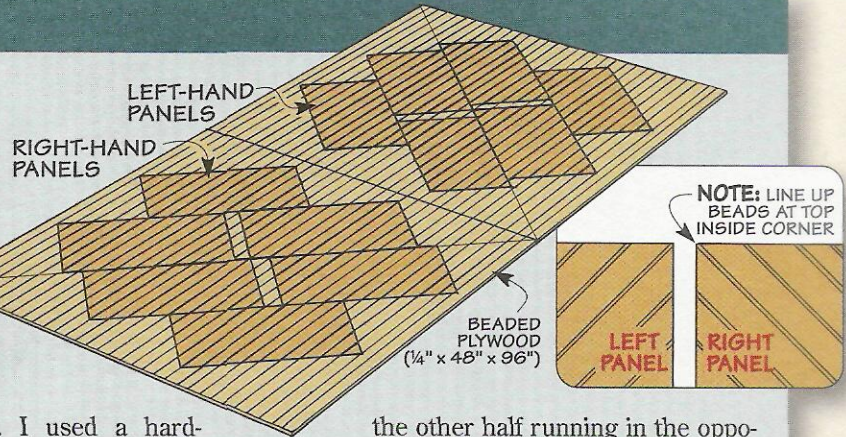

Cutting the diagonal panels for the doors isn't difficult. But it does take a little planning and some layout work.

Start by laying out the door panels at a 45° angle to the edge of the ply-

wood sheet. I used a hard-board template to do this, see photo. (In order for the beads on each pair of doors to match up, lay out half the doors running in one direction, and

the other half running in the opposite direction, see drawing above.)

Next, using a straightedge guide and a hand-held circular saw, cut the sheet of plywood in half, right down the middle. Now cut each half sheet in half again, but this time, cut from corner to corner, as you see being done in Figure 1. This will leave you with four triangular-shaped pieces.

Cut to Width – You can now cut the panels to width on the table saw. Simply place the long edge of the triangular piece against the rip fence as shown in Figure 2. Then cut the triangle into "strips."

After cutting all the panels to width, they can be cut to length on the table saw, using a miter gauge or a crosscut sled to support the workpiece.

Of course, you could also cut these panels out using an ordinary jig saw, band saw, or even a circular saw (although it might take a bit longer). Since the edges of the panels are covered by the frames, you don't have to be overly concerned with the quality of the cut.

When you assemble the doors, check to make sure that the beads on the left-hand door line up with the beads on the right-hand door, as shown above.

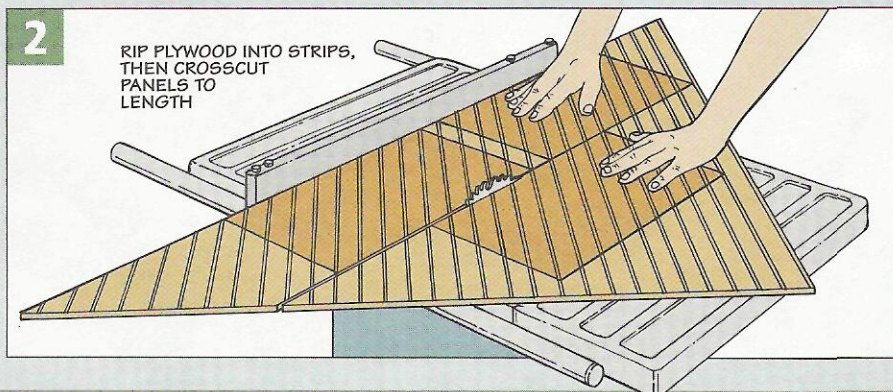
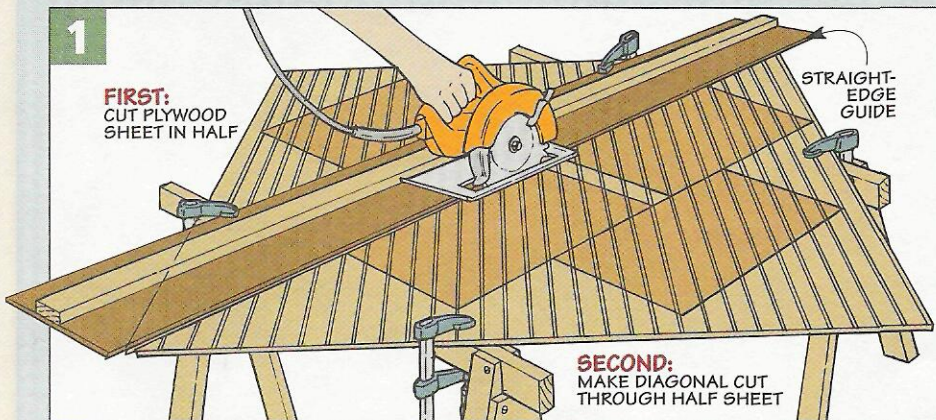

Two Favorite Pull Saws

When it comes to hand saws, cutting on the pull stroke is the way to go.

I still remember how amazed I was the first time I used a pull saw to make a cut. It was hard to believe that a saw that felt so light and flimsy could make an incredibly quick, straight, and accurate cut. Even today, it still amazes me. That's why I'm constantly reaching for one of my two favorite pull saws, the dozuki (backsaw) and kugihiki (flush cut saw) shown in the photo at right.

If you think about it, a saw that cuts as you *pull* the blade towards you makes sense. Since the blade is in tension, it can be much thinner. This gives the saw a couple added benefits. First, a thinner blade removes less material, so you don't have to work as hard to make a cut. And since you don't have to worry about the blade buckling or bending, the saw can be made from harder steel — so the teeth can be made much sharper.

Teeth – How sharp are the teeth? Imagine what it's like to slice some end grain with a newly sharpened chisel, and you'd be pretty close. A look at Figure 1a below will give you an idea why.

Each tooth on a pull saw (like the one shown in the margin) has three bevels. A traditional push-style backsaw only has two. The difference is the third bevel across the tip of each tooth. It's ground at an angle to form a point. (The teeth almost look like a set of minia-

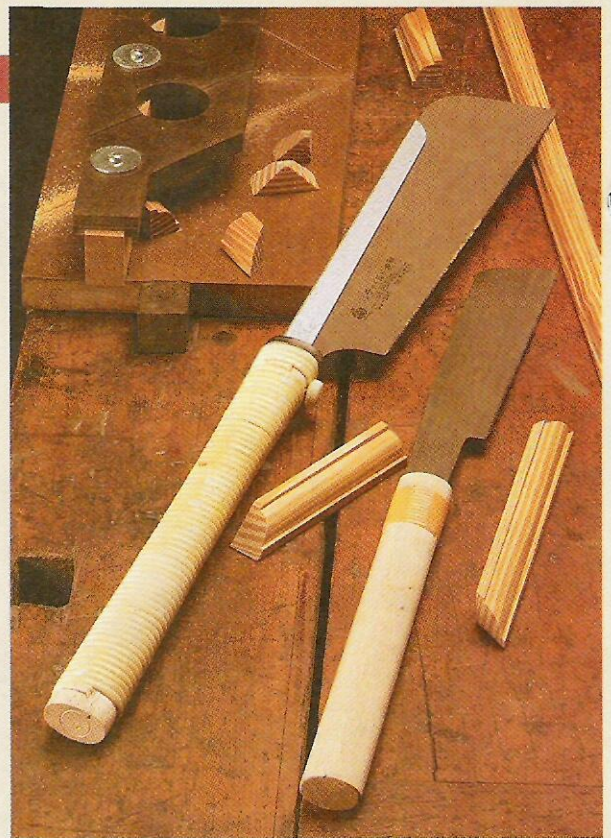

ture skew chisels.) Another difference is the set (flare) of the teeth (Figure 1b). Here again, it's less than a traditional saw, so it's easier to make a cut.

DOZUKI

Of my two favorite pull saws, the one I use the most is a dozuki (DOZE-ou-key) or Japanese "backsaw" (see margin). Whether I'm cutting fine joinery (like dovetails) or just trimming a workpiece to rough length, it's the saw I reach for most often. And when it comes to cutting small workpieces, the combination of a dozuki and the Pull Saw Miter Box (page 18) can't be beat. Note: Dozukis range widely in price, but a good quality one should only cost you around \$30 to \$40. For sources, refer to page 31.

Like a traditional backsaw, the dozuki has a rigid, metal "back." This provides extra support for the blade to minimize any chance of buckling — especially as you slide the saw forward for the next stroke. But it does limit the depth of cut you can make with the saw. I don't find that to be a problem since I rarely use it to cut anything more than 3/4" thick. If you expect to cut thicker stock often, you can find similar saws without a back.

Grip – The long handle on the saw makes it easy to maintain a light grip and still have good control. But if you've never used a dozuki before, you may find holding one a little odd. Start by gripping the saw as if you're shaking someone's hand. To help keep the saw aligned as I'm cutting, I like to extend my index finger along the side of the handle (Figure 1). This makes the saw feel like an extension of my arm.

Cutting – To start a cut, align the blade just to the waste side of the layout line. (Note: I use my thumbnail or knuckle as an alignment guide.) Then

Pull Saw Anatomy

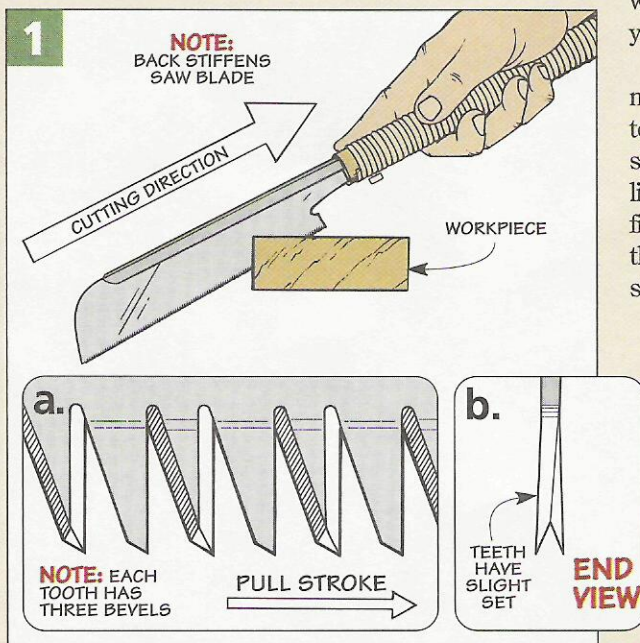
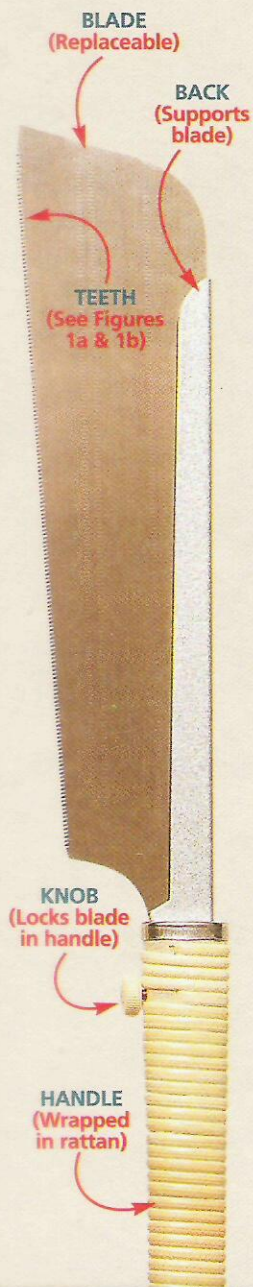

make easy strokes across the workpiece, letting the weight of the saw and the “grab” of the teeth do the work.

As you near the end, ease up just a bit. This way, you’ll avoid “shooting” through the workpiece and possibly hitting something (which can break the teeth). Note: If you do, you can buy a replacement blade for about half the price of a new saw. It’s also a good idea to protect the blade any time you’re not using the saw (see margin).

KUGIHIKI

Although the dozuki is my favorite saw, my kugihiki (COU-ghee-HEE-kee), or flush cut saw, comes in a close second. Like a dozuki, a kugihiki cuts on the pull stroke. But it also has a couple differences that make it the perfect choice for cutting off the “waste” parts of joints that need to be perfectly flush. For an example of this, take a look at the photo above right.

Flexible – First, the blade is ultra-thin and flexible. This makes it easy to “bend” the blade against the surface of a workpiece to make a cut.

No Set – The other difference is the teeth don’t have any set. So the kerf is the same width as the blade. This prevents the teeth from scratching the surface of a work-

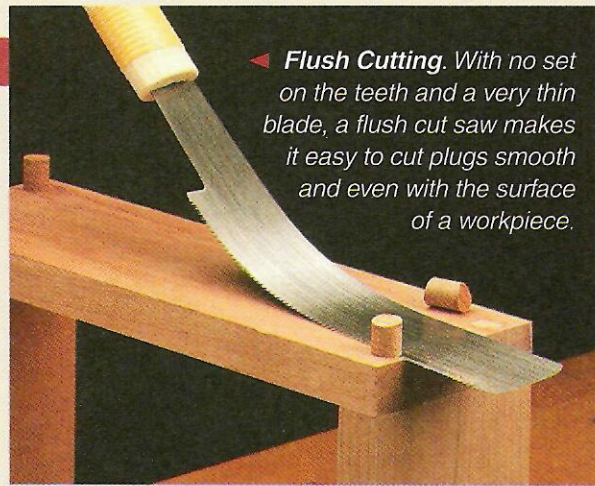

◀ **Flush Cutting.** With no set on the teeth and a very thin blade, a flush cut saw makes it easy to cut plugs smooth and even with the surface of a workpiece.

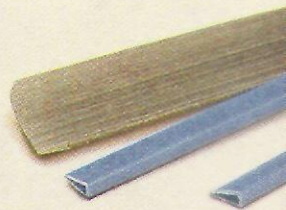

▲ **Protection.** A piece of binding bar from an ordinary report cover makes a perfect protector for the teeth of a pull saw.

piece. But this also means it’s easy for the blade to bind. So you need to be careful not to break or “kink” the blade — especially when cutting anything more than 1/2" thick.

A kugihiki saw used to be quite expensive. (I paid \$40 several years ago.) But you can buy one for less than \$20 now. For that price, it’s a must-have saw for my shop.

New & Improved – Some manufacturers have taken the concept of cutting on the pull stroke and designed new saws and accessories, as detailed in the box below. Although I won’t be giving up my two favorite saws, I’ll sure be taking a look at the new ones. 🛠️

New Pull Saws & Accessories

One of the more interesting products available today is the *Lee Valley/Veritas* dovetail guide and saw shown below.

Guide – The guide is a machined piece of extruded aluminum with features that make cutting dovetails almost foolproof. It all starts with a rare-earth magnet embedded in the guide. The magnet “grabs” the saw and holds it in perfect position as you make the cut (see photos below).

But don’t worry about the magnet holding too tight or marring the sides of the guide with a saw. That’s because there’s a piece of slick plastic (UHMW) for protection. And once you’re done with the tails, cutting the pins is just a matter of rotating the guide and then repositioning the clamp.

Saw – There is a downside. This guide can only be used with a pull saw (0.005" set per tooth) that *doesn’t* have a rigid

back. *Lee Valley* does offer a dovetail saw designed to work with the guide. It looks a little unconventional with its short, ribbed-plastic handle, but it does make a clean, accurate cut.

Compound Cutting Guide – Another new product is the *Vaughan* Perfect Free Angle Saw Guide and Bear Saw shown below. The unique thing about this guide is you can adjust it to cut miters, bevels, *and* compound cuts. The angles are all set at the back of the guide (see inset photo).

Saw – The saw has a removable, pistol-grip handle with a rubber coating that’s very comfortable. The teeth on this saw are larger (and there are fewer of them) than the ones on most pull saws, so it’s more suited for general carpentry work.

Sources – The *Lee Valley* and *Vaughan* saws and guides are available from the sources listed on page 31.

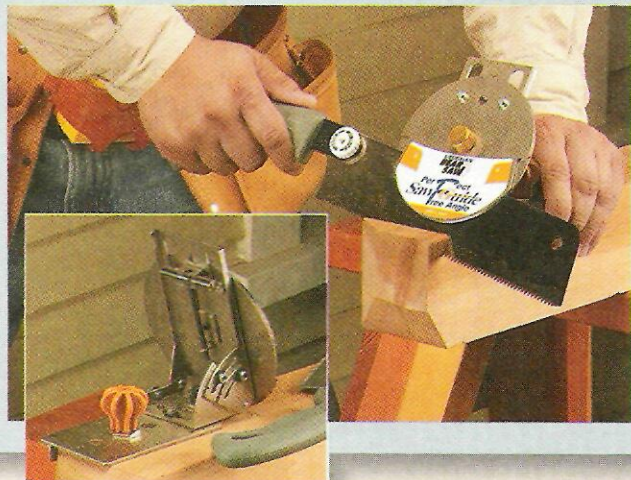
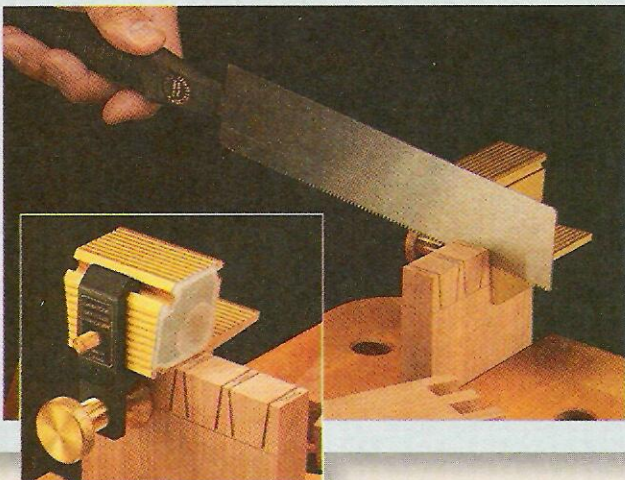

Pull Saw Miter Box

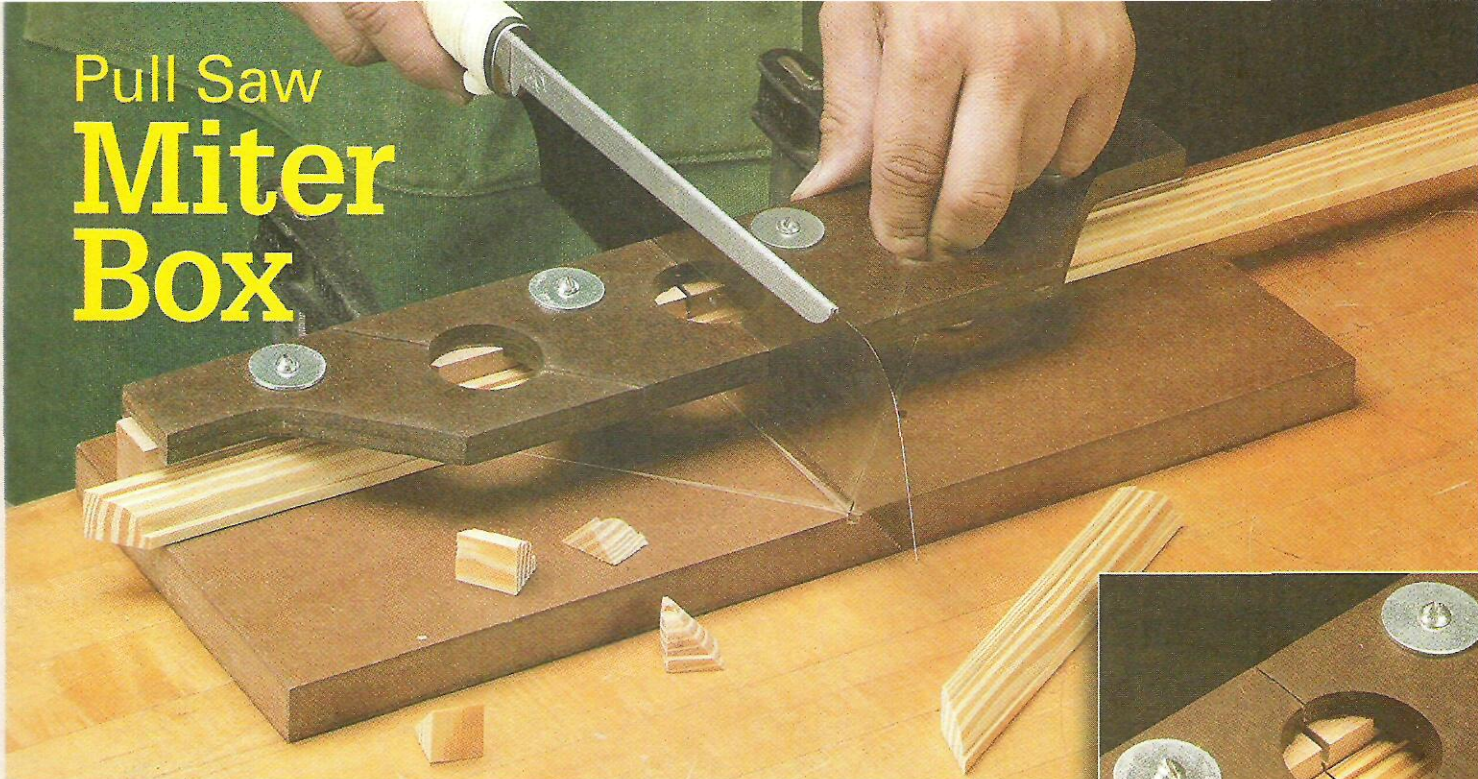

Cut small pieces accurately and safely with a pull saw using this shop-made miter box.

Working with small pieces is always a challenge, even when it's something as simple as cutting a workpiece to length or mitering an end. Using a table saw or power miter saw to do this can result in an uneven cut or tearout along the edge. Or even worse, the piece can literally explode as it's being cut.

So whenever I have to cut small pieces, I turn to a pull saw and the shop-made miter box shown above. The pull saw cuts a really narrow kerf with little to no tearout. And the miter box solves the tricky part of making an accurate cut.

Features – But this miter box has more going for it than most. To start with, guides attached to the top of the miter box are *adjustable*, so you can fit it to your saw. And they provide support for the three most common angles — 45° left, 45° right, and 90°.

To do this, the guides are held in place with large washers and screws that pass through oversized holes. This way, you can “squeeze” the guides against the blade of the pull saw for a snug fit.

You'll also notice some “port-holes” on the top of the miter box. As you can see in the inset photo above, it provides a convenient way to look through the top of the miter box and see the layout line for aligning the workpiece.

Finally, cutaways at the ends of the miter box make it easy to hold small workpieces as you make the cut or to clamp a stop in place for cutting a number of pieces to identical length. (To see how this works, turn to page 21.)

Parts – Another nice benefit is this miter box is quick to build. That's because it consists of only three main parts: a base, a fence, and a set of guides, as shown in Figure 1. I used a scrap of medium-density fiberboard (MDF) for the base, a

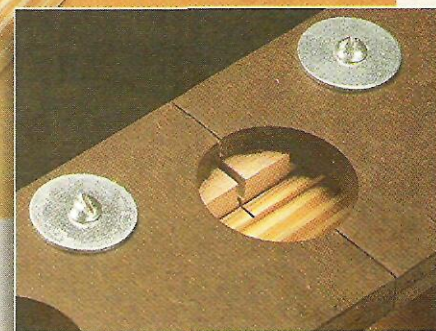

piece of 3/4"-thick hardwood for the fence, and two pieces of 1/4" hardboard for the guides.

Base & Fence – I started work on the miter box by cutting the *base* (A) and *fence* (B) to final size. Note: The width (height) of the fence allows you to work with stock up to 3/4" thick.

To keep the fence aligned during assembly, there's a shallow groove

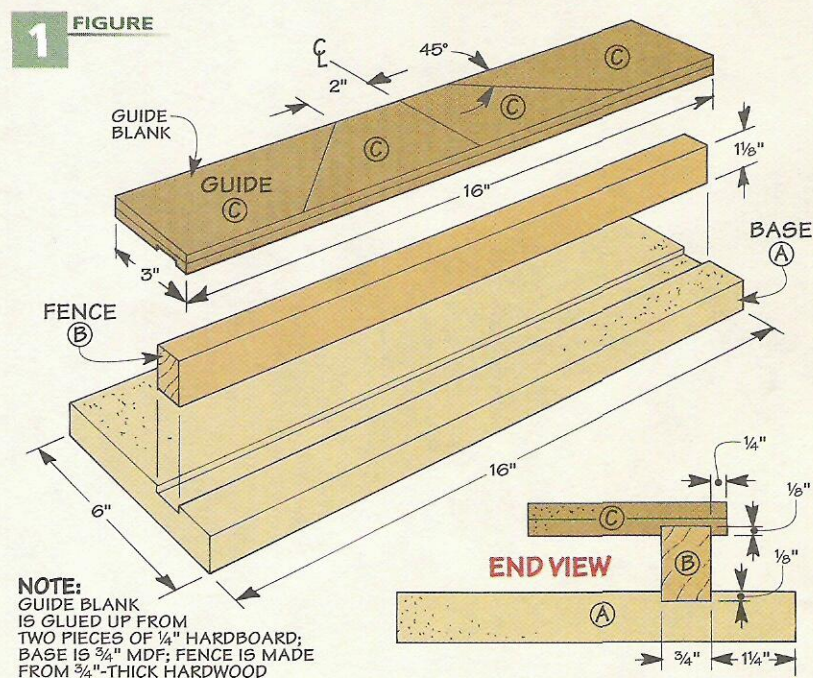

in the base, as shown in the End View below. Once the groove is cut, you can set the base and fence aside and begin work on the guides.

GUIDES

The heart of this miter box is the set of guides that fit over the top of the fence, as shown in Figure 1. These guides provide solid support for the saw as you make a cut.

To do this, the guides slide together and “sandwich” the blade of the saw. This keeps the blade perfectly straight and prevents it from wandering during the cut.

Guide Blank – Because these guides are rather small, I started with an oversized blank. This blank consists of two layers of 1/4" hardboard, as you can see in Figure 1.

After trimming the blank to final size, you're ready to cut a shallow groove in the bottom (Figure 1). Like the base, this groove helps to align the guides on the top of the fence during assembly.

Guides – Once the groove is complete, you're ready to cut the blank into four separate *guides* (C) (Figure 2). These pieces will form “slots” to guide the pull saw at three separate angles — one at 90° and the other two at 45° left and right.

I used the table saw to cut the guides to size. But before doing that, it's a good idea to check the alignment of your miter gauge.

Checking for 90° isn't difficult. For that I just use my try square. You can also use a try square to check

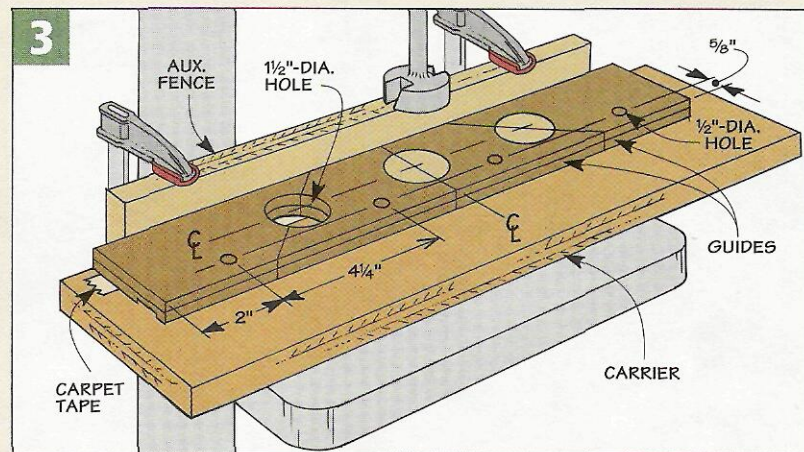
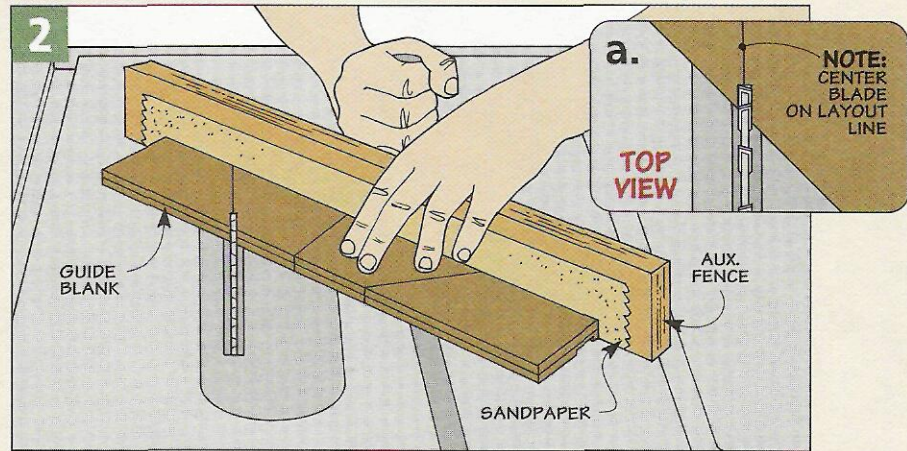

the 45° angle for accuracy, as shown in the margin tip at right.

To ensure the blank doesn't slide around as you make the cuts, attach an auxiliary fence and a strip of sandpaper to the miter gauge. Then cut the guides to size (Figures 2 and 2a).

Circular Cutouts – Now you can turn your attention to the circular cutouts. These cutouts are just centered holes drilled along the joint

line between each guide.

Drilling a hole across a pair of guides is a challenge. So I made a carrier to hold the guides, as you can see in Figure 3. To keep the guides from slipping, they're held in place with carpet tape. And a fence clamped to the table of the drill press positions the guides accurately.

Mounting Holes – While I was at it, I drilled a mounting hole in each guide. These holes are centered over the groove in each guide. And they're oversized to allow you to adjust the guides once they're installed.

Cutaway – There's one last thing to do to the guides before they can be installed. And that's to make a curved cutaway on the two outside guides so it's easy to clamp or hold a small workpiece. As you can see in Figures 4 and 4a, a band saw makes quick work of removing the waste.



▲ **Miter Check.** To check the 45° setting on your miter gauge, cut a scrap in two and form a right angle. If it checks square, the 45° setting is accurate.

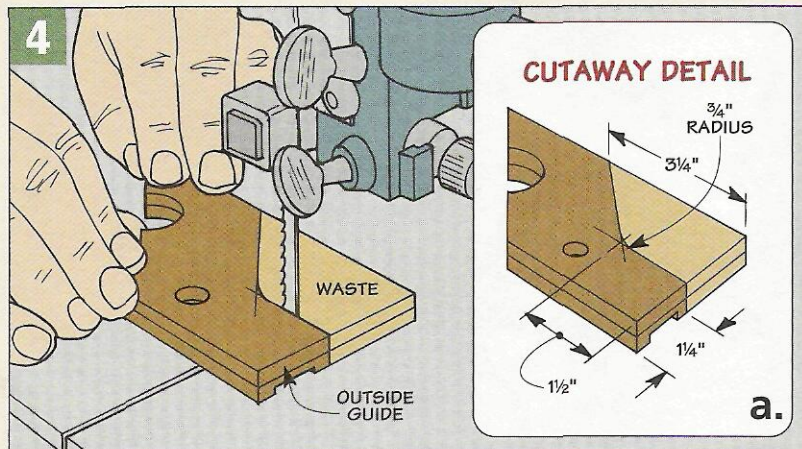

Assembly



▲ Notch for Teeth.

To avoid widening the slot between the guides, the teeth of the saw blade rest in a notch cut in the top of the fence.

Now that all the parts of the miter box are complete, you're just about ready to assemble everything. However, because the teeth of the pull saw have set (flare out at the bottom), they create a small problem.

The guides of the miter box are designed to sandwich the *blade* of the saw. So if you try to feed the saw between the guides, the teeth will cut into them, widening the slot and creating a loose fit.

Clearance for the Teeth – To solve this problem, I added a set of notches to the top of the fence, as shown in Figure 5. As you can see in the margin photo, this notch provides a resting spot for the teeth of the saw. Note: For this to work, you'll need to feed the blade of the saw into the miter box with the teeth below the guides, but more about that later.

Locate Notches – The first thing to do is to locate the position of each notch. As you can see in

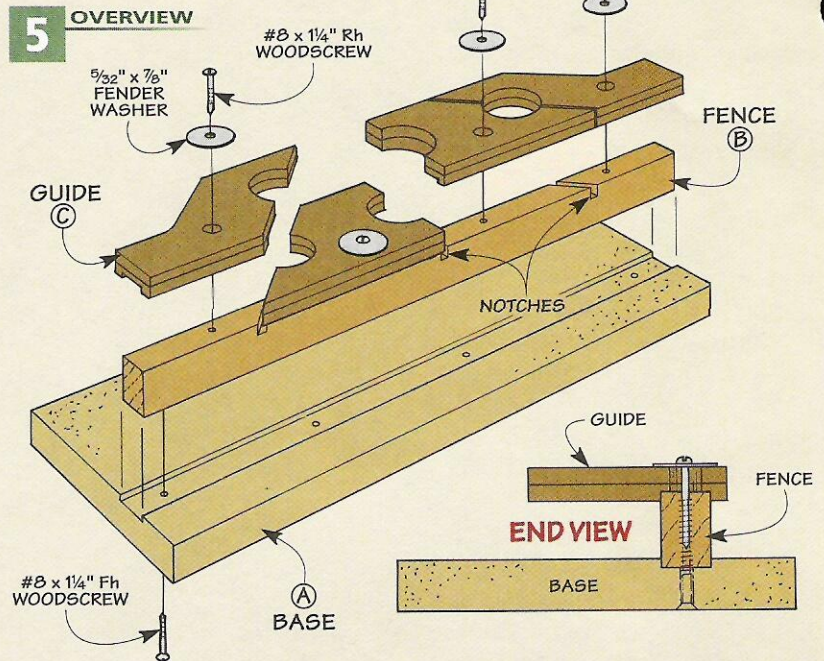

Figures 6 and 6a, locating the layout line at 90° is easy. Just make a mark at the center of the fence.

But for the 45° position on each side of the center, I didn't use any

measurement. Instead, I used the guides to locate the notches.

Just fit one of the center guides over the top of the fence so the 90° edge is aligned with the mark you just made on the fence (Figure 6). Then on the opposite edge, make a another mark for the location of the 45° notch. To locate the other 45° notch, simply repeat the process using the other 90° guide.

Cut Notches – Now you're ready to cut the notches on the table saw. Here again, when making cuts like this, it's a good idea to attach an auxiliary fence to your miter gauge along with a strip of self-adhesive sandpaper, as you can see in Figure 7.

This solves two problems. First, the auxiliary fence prevents chipout on the back side of the workpiece. And second, the sandpaper keeps the workpiece from slipping as you make the cut.

After cutting a 1/4"-deep kerf at all three locations (Figure 7a), you can screw the fence to the base of the miter box, as illustrated in the End View of Figure 5.

Attach Guides – At this point, you can turn your attention to attaching the guides to the top of the fence. The first step is to fit the two

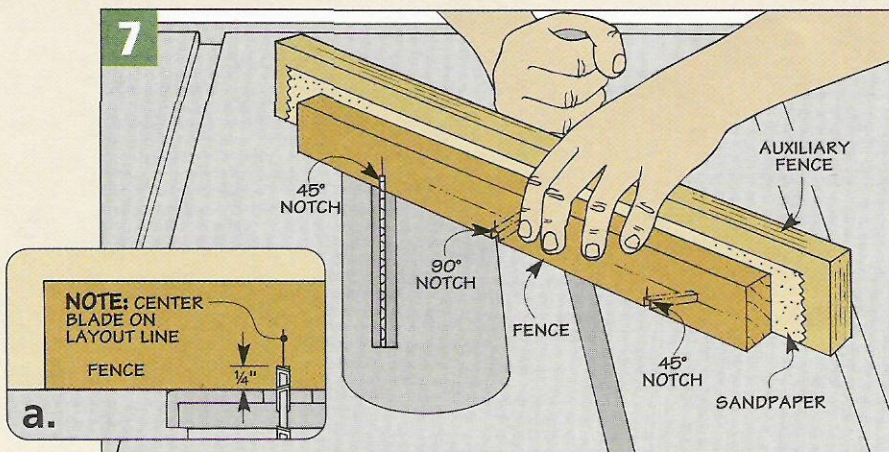
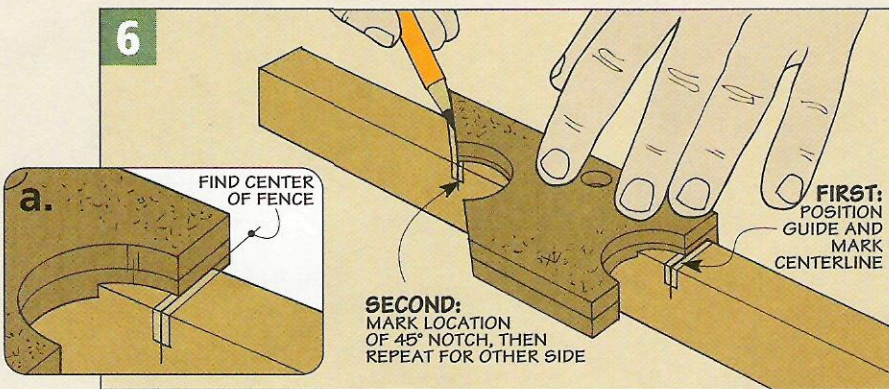

center guides over the fence and make a mark for the mounting holes on the top of the fence. The marks don't have to be perfectly centered since the oversized holes allow plenty of room for adjustment.

After drilling pilot holes at these marks, attach the two center guides loosely, as illustrated in Figures 8 and 8a. Then feed the saw between the guides so the teeth rest in the center notch (Figure 8b).

Now slide the guides against the blade of the saw and sandwich it in place. Then tighten the screws on the top of each guide. What you're looking for here is a snug fit against the blade, but not so tight that it binds and prevents the blade from sliding back and forth.

To locate the outside guides, just repeat the process. But since the center guides are already positioned, you only have to concentrate on one guide at a time.

USING THE MITER BOX

At this point, you're almost ready to start using the miter box. But before cutting any workpieces, it's a good idea to make an initial cut through the fence at each position. To prevent the box from moving around, clamp it in place (Figure 9).

Then position the teeth below the bottom of the guides and slip the saw in place from the *back* of the miter box. This prevents two problems. First, you don't have to worry

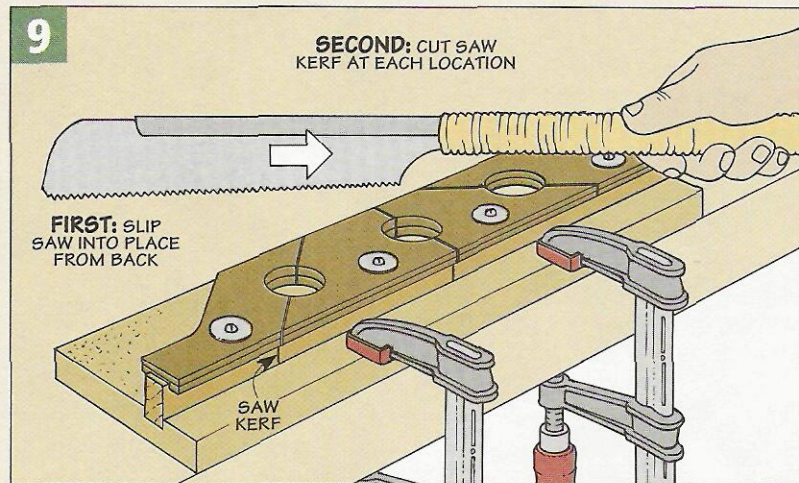
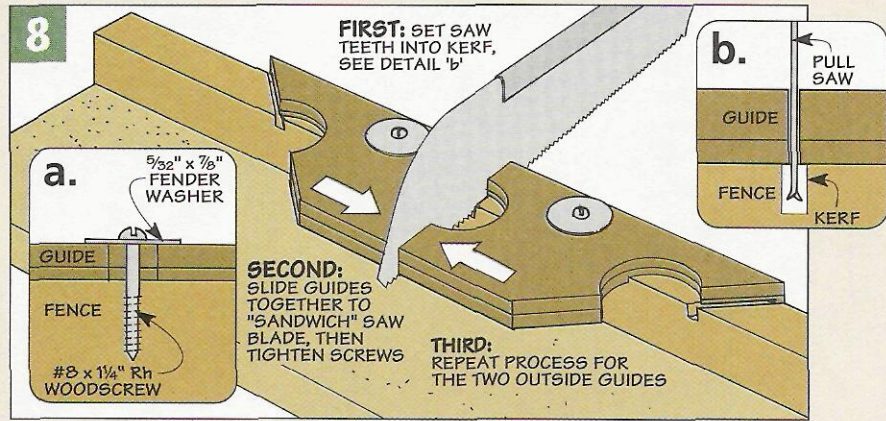

about "buckling" the blade of the saw as you try to feed it into the opening from the front. And second, the teeth won't cut into the guides and widen the slot.

All you need to do now is pull the saw back and allow it to cut its own kerf all the way down to the base. Repeat this process to cut the kerfs

at the two 45° positions.

Once all the kerfs are cut, you're ready to put the miter box to use. Although you'll probably find a number of jobs perfectly suited for this miter box, the photos below show a couple of my favorite uses for cutting small workpieces quickly, accurately, and safely.

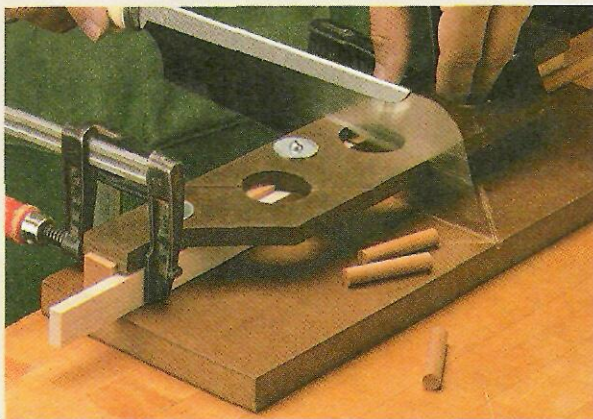

▲ **Cutting Dowels.** The cutaway at the end of the guide makes it easy to clamp a stop in place and cut small pieces, like the dowels above, to identical length.

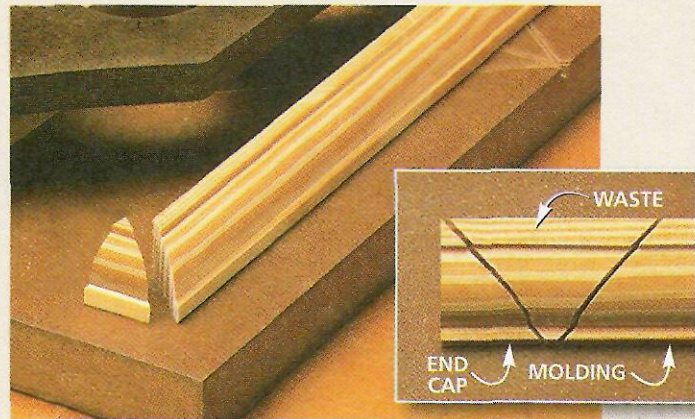

▲ **Molding.** Cutting a small piece, like the end cap above, is easy and safe. First, cut an end cap off the molding (see inset), then make a second cut to remove the waste.

Sliding-Door Wall Cabinet

Looking for a way to maximize wall storage? This cabinet does that — and a little bit more.

There never seems to be enough storage space in a workshop. Especially when it comes to wall storage. It's always in short supply. One way to "add" storage is to make the most of the space you do have. The wall cabinet shown at right is designed to do just that.

At first glance, the cabinet doesn't look all that unusual. But a closer look reveals a couple things that make this cabinet a bit different than most.

Customized Storage – Open the cabinet and you won't find tools sitting on fixed shelves. Instead, they're stored on shop-made tool holders that mount to a piece of $\frac{1}{4}$ " pegboard (right photo below). This provides a lot of flexibility, making it easy to organize the interior to suit *your* tools (and rearrange things as you add new ones). For more on the tool holders, refer to the article on page 28.

Doors – Another difference is the doors of the cabinet. They're just as useful as the pegboard when it comes to maximizing wall space.

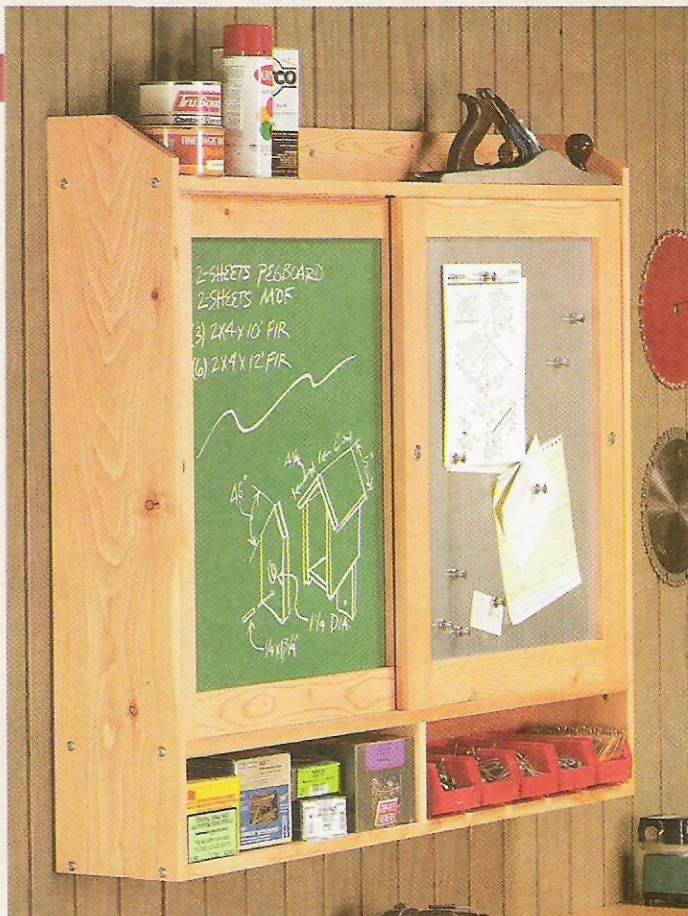

That's because one of the door panels is covered with sheet metal (left photo below). Along with a set of magnets, it makes it easy to attach notes and plans to the door. And the other panel? It's covered with chalkboard paint. So you can easily jot down a reminder note or a shopping list as you work (center photo below).

One last thing. You won't have to spend much time fitting the doors to the cabinet. That's because there aren't any hinges. Instead, they open and close easily by sliding back and forth in grooves in the cabinet (right photo).

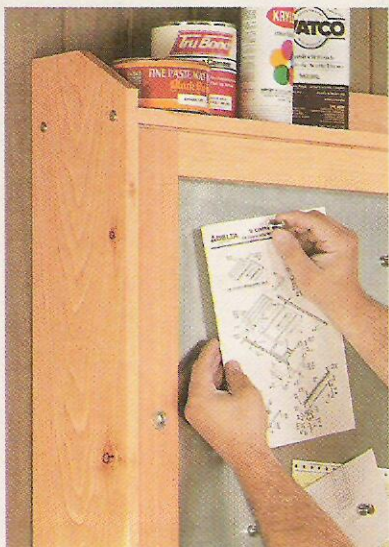

▲ **Metal Door.** A sheet metal panel is a convenient way to attach plans or pictures using small magnets.

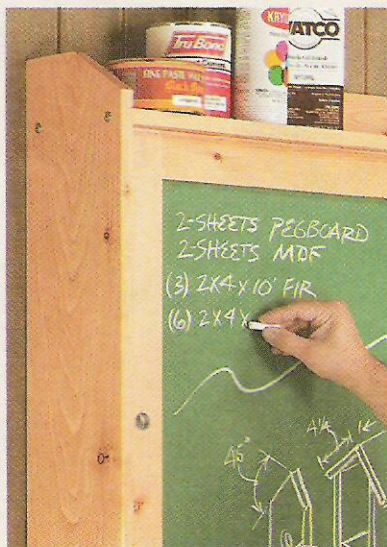

▲ **Chalkboard.** Jotting down project notes or a shopping list is easy on a door sprayed with chalkboard paint.

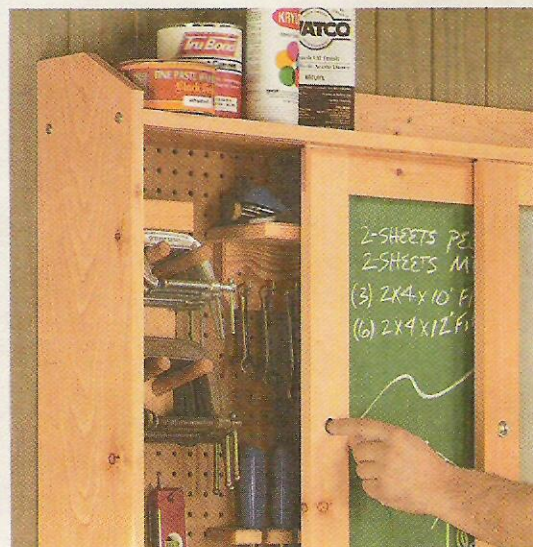

▲ **Sliding Doors.** Sliding open the doors of the wall cabinet reveals an interior you can customize with shop-made tool holders.

EXPLODED VIEW
OVERALL DIMENSIONS:
 48¹/₈" W x 7¹/₂" D x 38" H

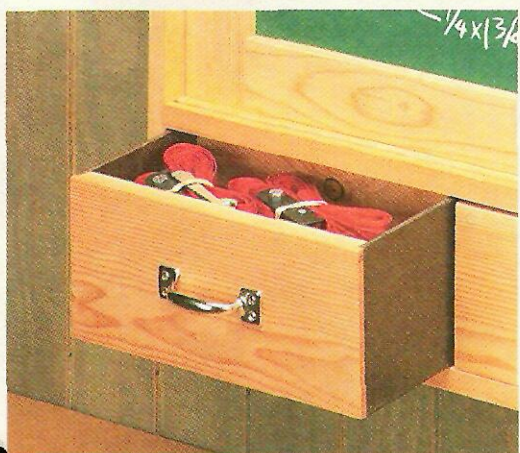
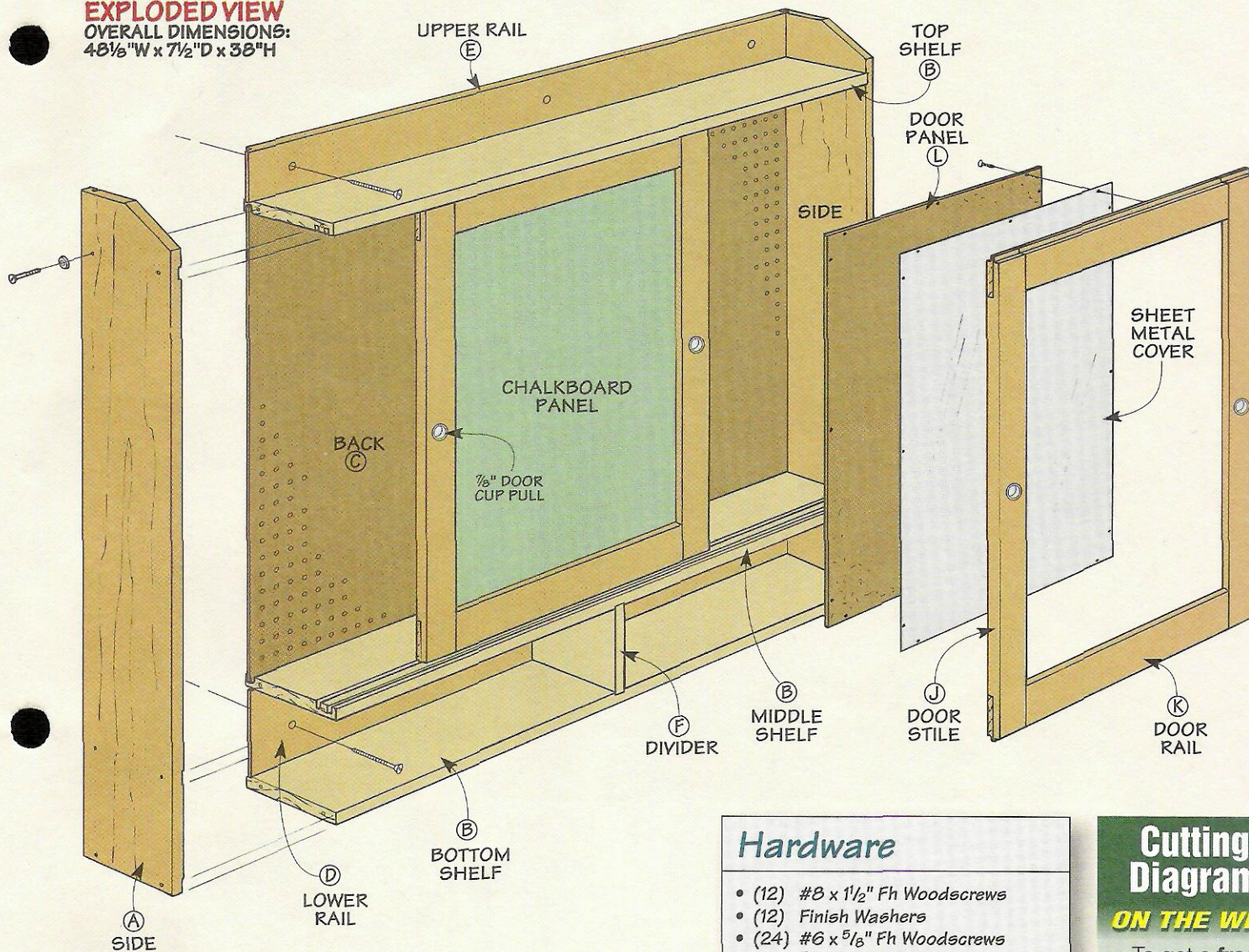

▲ **Drawers.** Instead of using plastic storage bins, you can build drawers for the wall cabinet. For more on this, refer to the box on page 26.

Hardware

- (12) #8 x 1¹/₂" Fh Woodscrews
- (12) Finish Washers
- (24) #6 x 5¹/₈" Fh Woodscrews
- (4) 7¹/₈" Door Cup Pulls
- (4) 4" Drwr. Pulls w/screws (Opt.)

Materials

Case

- | | |
|-----------------------------------|---|
| A Sides (2) | $\frac{3}{4}$ " x 7 ¹ / ₂ " - 3B |
| B Top, Middle, & Btm. Shelves (3) | $\frac{3}{4}$ " x 7 ¹ / ₂ " - 46 ³ / ₄ |
| C Back (1) | 28 ¹ / ₄ " x 47 ¹ / ₄ " - 1 ¹ / ₄ " Pgbd. |
| D Lower Rail (1) | $\frac{3}{4}$ " x 5 ¹ / ₄ " - 47 ¹ / ₄ |
| E Upper Rail (1) | $\frac{3}{4}$ " x 3" - 47 ¹ / ₄ |
| F Divider (1) | $\frac{3}{4}$ " x 6 ³ / ₄ " - 5 ¹ / ₂ |

Drawers (Optional)

- | | |
|---------------------------|---|
| G Drawer Fronts/Backs (8) | $\frac{3}{4}$ " x 5 ¹ / ₈ " - 11 ¹ / ₄ |
| H Drawer Bottoms (4) | $\frac{3}{4}$ " x 6 ¹ / ₄ " - 10 ³ / ₄ |
| I Drawer Sides (8) | 5 ¹ / ₈ " x 6 ¹ / ₄ " - 1 ¹ / ₄ " Hdbd. |

Doors

- | | |
|-------------------|---|
| J Door Stiles (4) | $\frac{3}{4}$ " x 2 ¹ / ₂ " - 27 ¹ / ₈ |
| K Door Rails (4) | $\frac{3}{4}$ " x 2 ¹ / ₂ " - 24 ¹ / ₂ |
| L Door Panels (2) | 20 ¹ / ₄ " x 23 ⁵ / ₈ " - 1 ¹ / ₄ " Hdbd. |

Cutting Diagram

ON THE WEB

To get a **free** cutting diagram for this project:

Visit us on the Web at **ShopNotes.com**

Or send a stamped, self-addressed envelope to:

ShopNotes
 Cutting Diagrams
 Wall Cabinet
 2200 Grand Ave.
 Des Moines, Iowa
 50312

Case

1 FIGURE

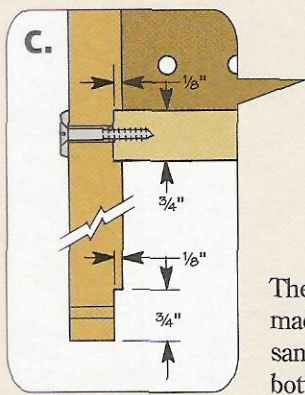
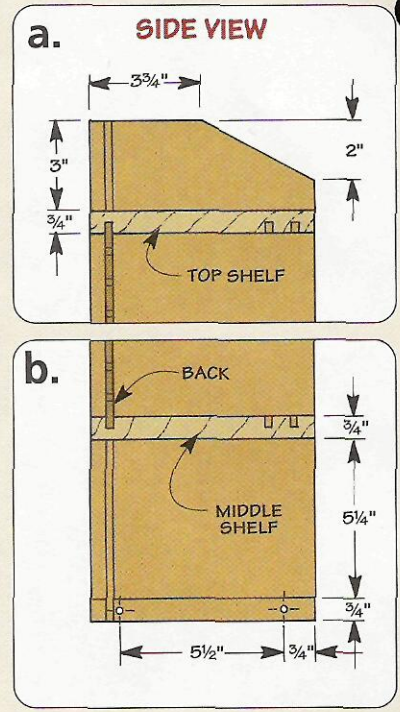
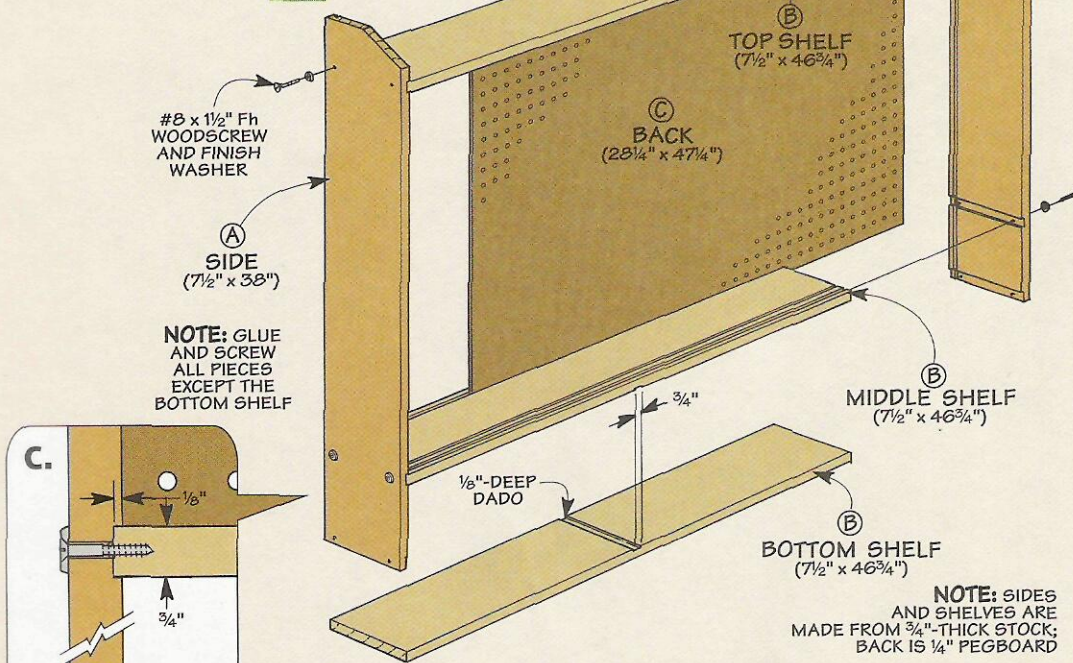

The basic case of the wall cabinet is made up of three shelves and a back sandwiched between two sides. The bottom shelf is divided into two separate areas for holding plastic storage bins or optional drawers.

Material – Now's a good time to mention a little about the material used to build this case. The shelves and sides are fairly wide (7 1/2"). I was able to cut them from some 1x10 pine. (Available at most home centers and lumberyards.)

But if you can't find any straight,

flat boards that wide, that's not a problem. It's easy enough to glue up the parts from narrower boards.

Regardless of how you make the pieces for the case, be sure to select boards that are all the same thickness. If they aren't, you'll want to plane them a little before you start building. This way, all the dados and rabbets used to join the case together can be cut the same width.

Cut Pieces – With your material in hand (or panels glued up), you're ready to cut the *sides* (A) and the

top, middle, and bottom shelves (B) to the final sizes shown in Figure 1. Shop Note: Because the sides and shelves are fairly long, it's a good idea to attach a long auxiliary fence to your miter gauge to provide support as you crosscut them.

Joinery – With the pieces cut to size, the first thing to work on is the joinery for the sides of the case.

Start by cutting the shallow dados and rabbets to accept the shelves (Figures 1a, 1b, and 1c). Here again, the long auxiliary fence will help provide support for the cuts.

Then to accept the back and rails of the cabinet (added later), cut a narrow groove near the back edge of each side (Figures 2 and 2a). Finally, I cut away the corner at the top of each side, as shown in Figure 1a.

Shelves – If you look closely at Figure 1, you'll see there's an identical groove near the back edge of the top and middle shelves. Like the sides, these grooves help hold the back in place. (You can use the same setup on the table saw as you did for cutting the groove in the sides.)

The next step is to cut a pair of grooves near the *front* edge of both

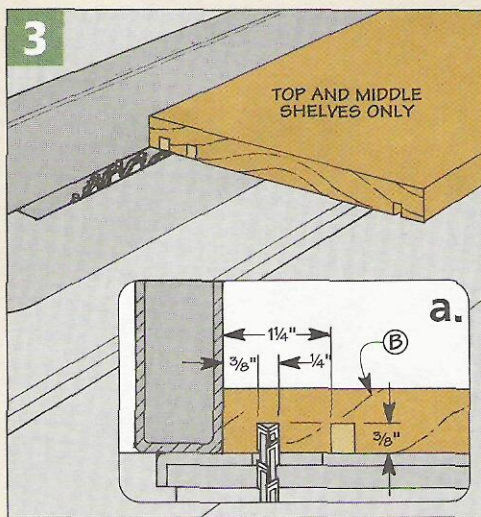
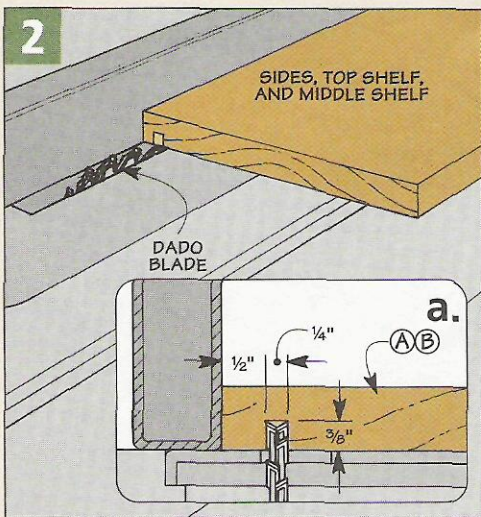

the top and middle shelves (Figures 3 and 3a). These grooves provide a "track" to guide the doors as they slide. The grooves are positioned so the two doors can slide past each other without interference.

Before you can assemble the case, there's one more thing to do. And that's to cut a centered dado in the middle and bottom shelves to accept a small divider (Figures 1 and 4).

Assembly - At this point, I assembled the main part of the case. To do this, I cut the *back* (C) to fit into the grooves in the sides and shelves. Then I glued and screwed everything together *except* the bottom shelf (Figure 1).

Rails & Divider - Why not add the bottom shelf? The *lower rail* (D) needs to be in place first (Figure 4c). And since the *upper rail* (E) shown in Figure 4b is almost identical (it's just narrower), I made it at the same time. After cutting the rabbets at both ends of each rail (Figure 4a), glue the rails in place.

All that's left at this point is to size the *divider* (F). It's trapped between the dados in the two lower shelves. Finally, glue and screw the bottom shelf in place to complete the case.

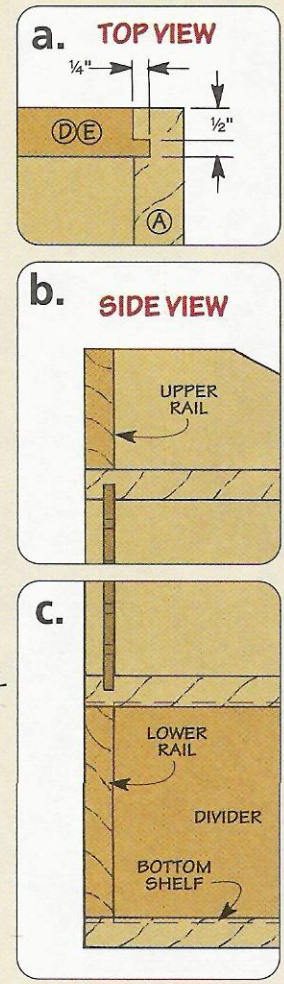
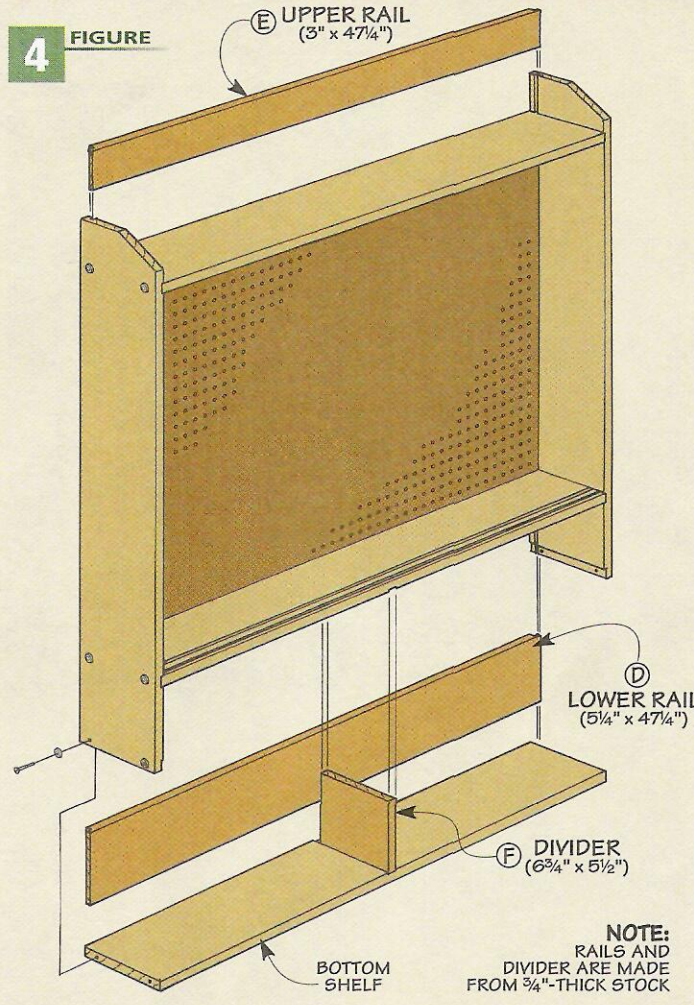

Optional Drawers

Open plastic bins are a great way to store hardware. The only problem is they collect dust. To solve this, you might want to add the shop-made drawers shown in the photo and drawing at right.

The construction of the drawers couldn't be much simpler. Each pair of drawers is sized to fit the opening on either side of the divider. I used solid 3/4"-thick stock for the *front* (G), *back* (G), and *bottom* (H) of each drawer. But for the *sides* (I), I used 1/4" hardboard.

The ends of the front and back are rabbeted to hold the sides (detail 'a'). And a second rabbet along the lower edge holds the drawer bottom (detail 'b'). Once all the pieces are sized, just glue the drawers together and center a metal pull on the front of each.

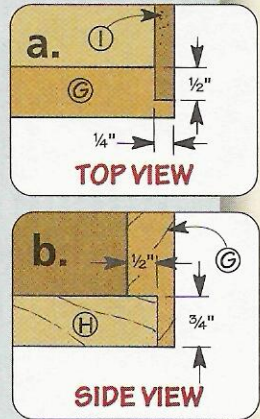
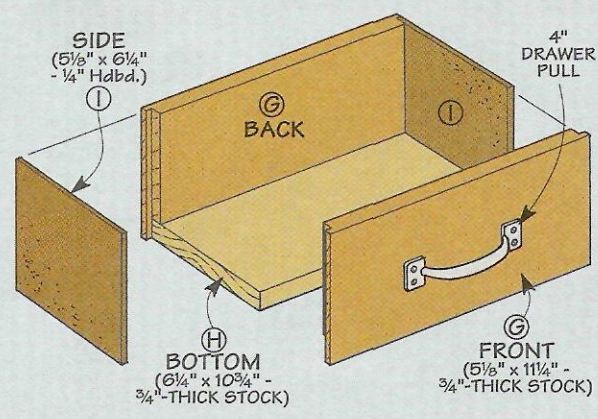
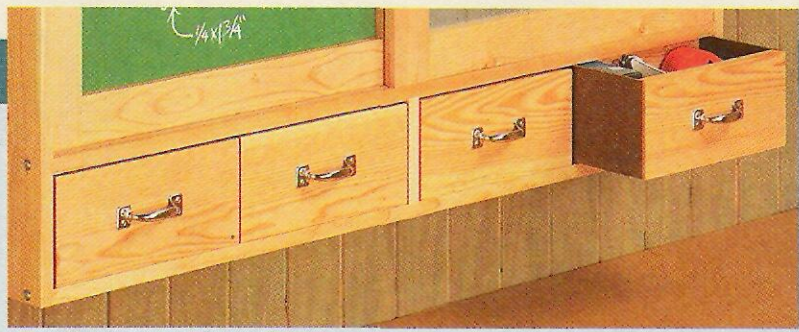

Doors

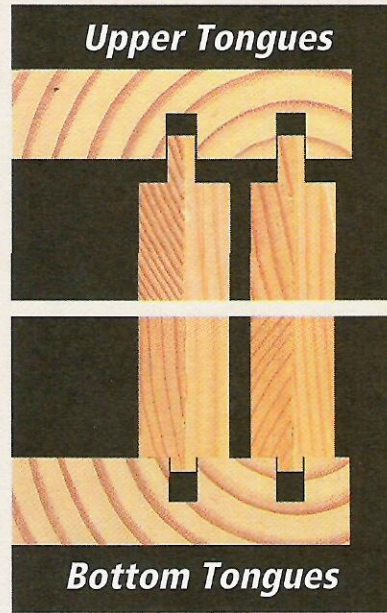

At this point, the basic case is complete. All that's left to do is add the sliding doors that fit into the grooves you cut earlier in the shelves. But now that the cabinet is assembled, how do you go about installing them?

The answer is shown at left. Tongues cut on the top and bottom of the door fit into the grooves. But you'll notice that the upper tongue is longer than the bottom one.

This way, you can slip the door further into the upper groove, allowing you to swing the bottom of the door into the cabinet. When you "drop" the lower tongue into the bottom groove, the upper tongue is long enough to keep the door in place.

Stiles & Rails - Each door frame is identical and consists of a pair of *stiles* (J) and *rails* (K) cut from 3/4"-thick stock (Figure 5). I cut the stiles to length (27 7/8") so they were slightly longer (3/8") than the height of the opening. And the rails are cut to length (24 1/2") so the frames overlap at the center.

Half Laps - With the pieces cut to size, you can concentrate on the half laps that hold the frame together (Figure 5a). Note: To learn a few tips on cutting a perfect half lap, turn to the article on page 30.

Tongues - After gluing the frames together, you can turn your attention to the tongues at the top and bottom of the frame.

Cutting the tongues is a quick task on the table saw. All it takes is a

5 FIGURE

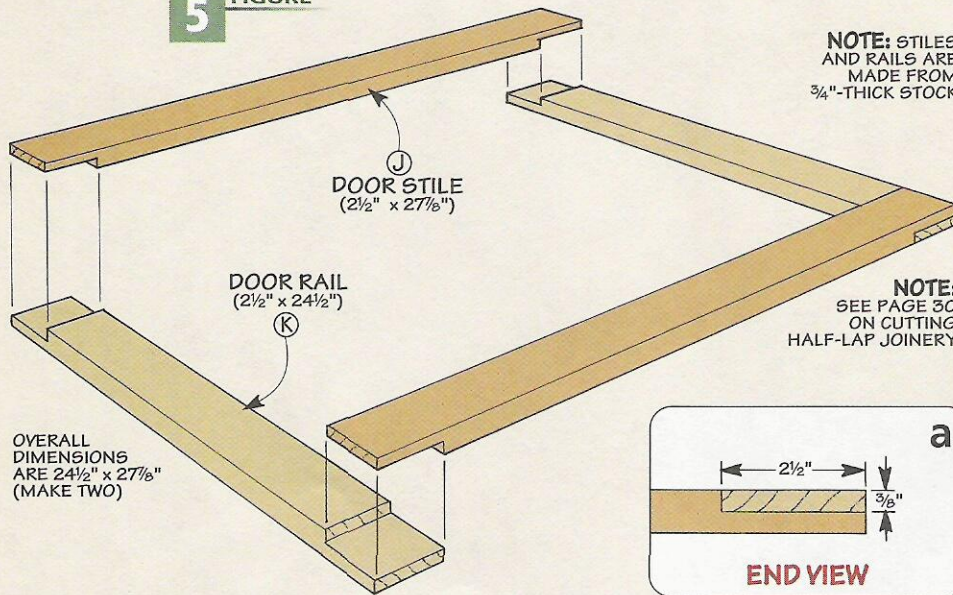

dado blade "buried" in an auxiliary fence, as shown in Figure 6. As you do this, just keep in mind that the upper tongue is longer than the bottom one (Figures 6a and 6b).

Rabbet – All that's left to complete the frame is to rout a $\frac{5}{16}$ "-deep rabbet in the back for the door panel (Figure 7a). After routing the rabbet (Figure 7), square up the corners with a chisel (see margin drawing).

Panels – Now you're ready to add the panels. As you can see in the photos below, you have a few options. But they all start out as a $\frac{1}{4}$ " hardboard panel (L) cut to fit the opening in the frame (Figure 8).

Once the panels are cut to size, you could just screw them into the rabbet, as shown in Figure 8a. But if you're looking to make better use of your wall space, you might want to consider a couple options.

Chalkboard – In the center photo you'll see a door that looks like it might be more at home in a classroom. That's because the panel is covered with chalkboard paint. (It's available at most home centers.)

Simply spray the panel with the paint, and once it's dry, you can easily jot down a quick note or write up a shopping list. A swipe with an eraser, and it's ready for new notes.

Sheet Metal – The door shown in the photo below right uses a different approach. Instead of paint, the panel is covered with a piece of sheet metal. (Here again, you can find this at most home centers.)

This way, you can use magnets to

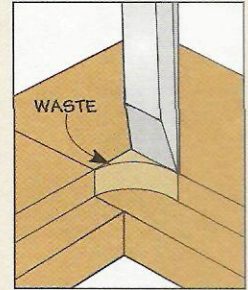
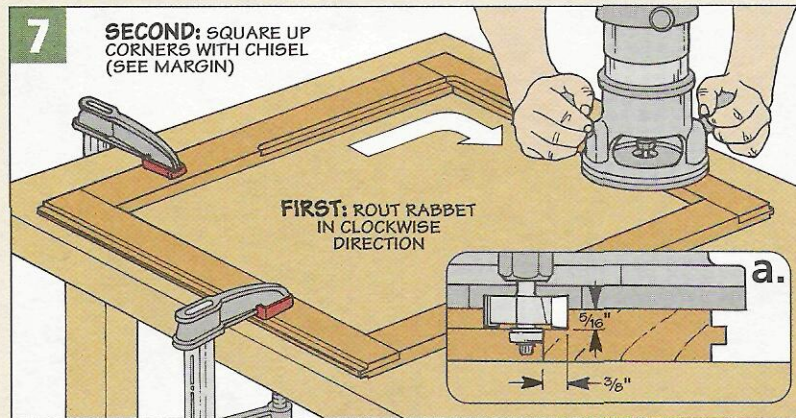

▲ A chisel makes quick work of squaring up the corners of a rabbeted frame.

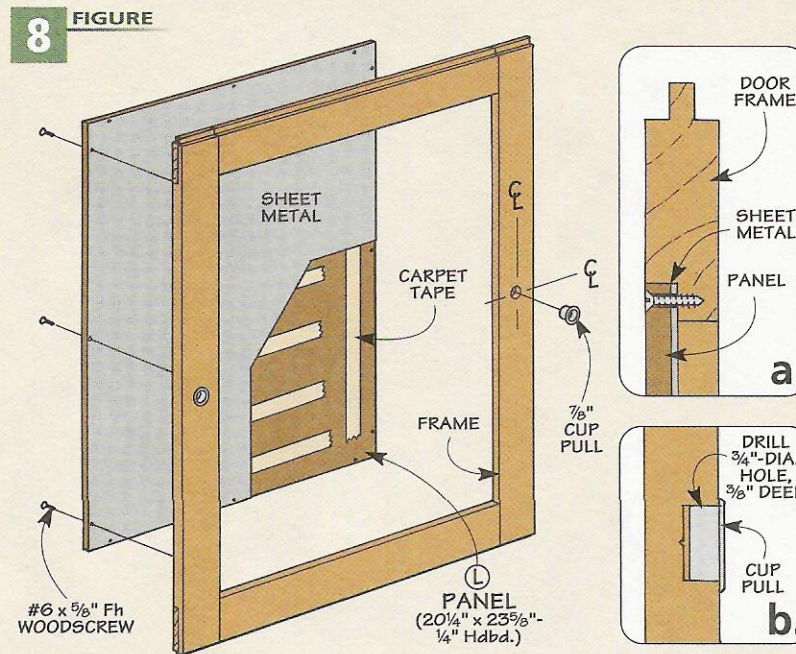

attach items to the door like on a refrigerator. The sheet metal is attached to the panel with carpet tape. Note: Because the magnets stick out past the frame, you'll only be able to install one door with sheet metal.

Add Pulls – To make it easy to open and close the doors (and still slide past each other once they're installed), I added cup pulls that fit into shallow holes drilled into the center of each stile (Figures 8 and 8b).

Mount Cabinet – Before installing the doors, I found it easiest to mount the cabinet to the wall. The cabinet is screwed to the wall studs through the upper and lower rails (refer to Exploded View on page 23).

Install Doors – With the cabinet in place, all that's left to do is install the doors. Start by slipping the upper tongue into the back groove in the upper shelf (see opposite page). Then swing the bottom of the door into the opening and lower it into the mating groove. Finally, repeat the process for the other door.

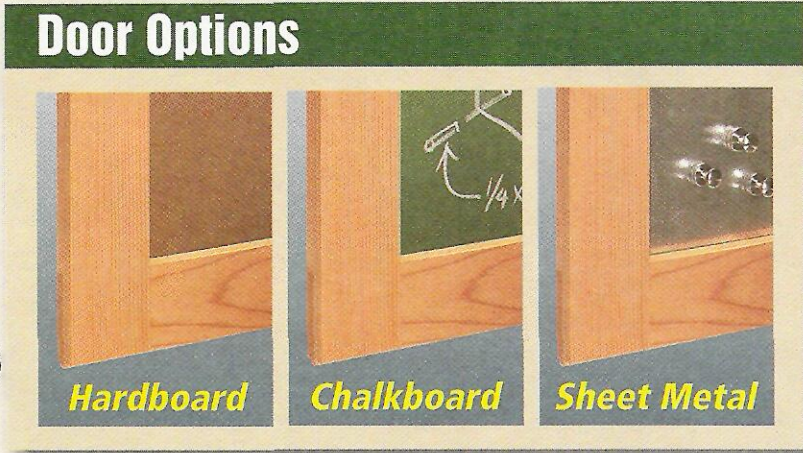

Pegboard Tool Holders



Add versatile storage to any pegboard with shop-made tool holders.

One thing that makes the Wall Cabinet shown on page 22 so versatile is that the back of the cabinet is made from a piece of 1/4" pegboard. Now that might seem like an odd choice. But in this case, it makes it easy to customize the storage inside with some shop-made tool holders.

Custom Holders – As you can see in the main photo, the holders are designed to store a wide variety of hand tools. There's even a shelf for storing odd-shaped items, like the hand planes shown below.

L-Hooks – But all the holders have one thing in common. And that's the ordinary L-hooks used to mount the holders to the pegboard. The advantage of using L-hooks is

they can't fall off and the position of the holders isn't permanent.

Now you might think this feature would make it difficult to install the tool holder on the pegboard in the first place. But that's not the case.

All you need to do is tilt the holder so the L-hooks slide into the holes of

the pegboard (left inset photo above). Then lower the holder against the pegboard so the weight of the holder "locks" the L-hooks in place (right inset photo). This makes it almost impossible for the holders to fall out, yet still makes them easy to move as your needs change.

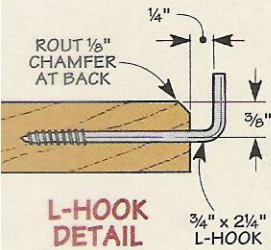
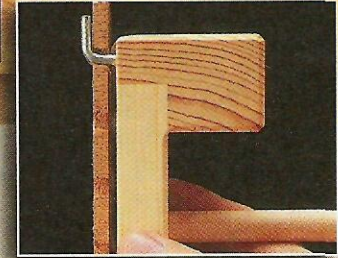
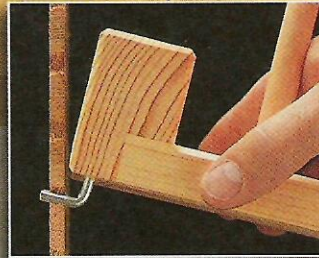

Shelf & Hooks



When it comes to storing odds and ends, like the set of hand planes shown in the photo above, a shelf that hangs on the pegboard is the perfect solution.

Now you could just screw a couple hooks in the back of a single board to make a shelf. But to provide more support, I glued and screwed a back piece to the bottom edge of the shelf, as illustrated in the drawing at right.

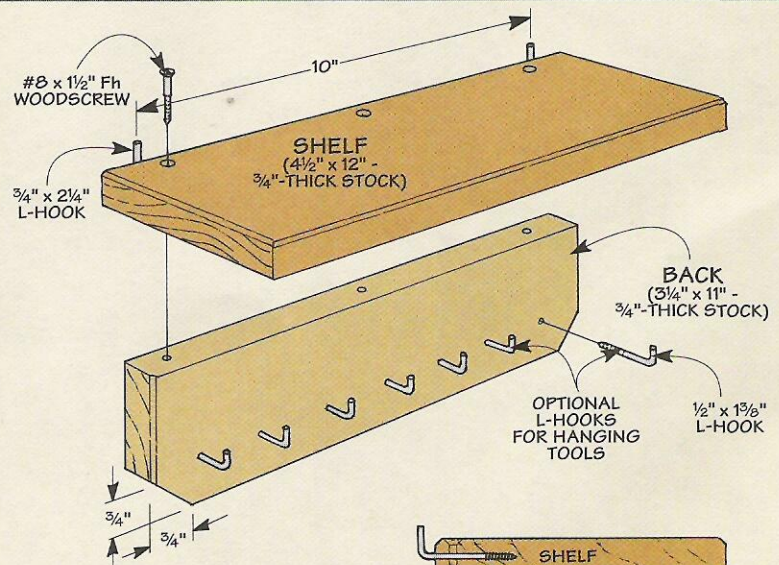

Besides the additional support, adding the back also provides a spot to screw in several more L-hooks. These hooks create a convenient place to hang a few extra hand tools.

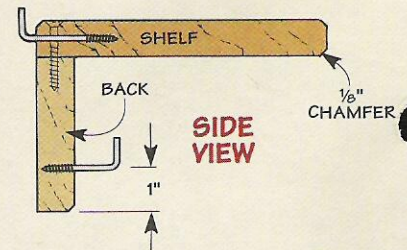

Chisels & Screwdrivers

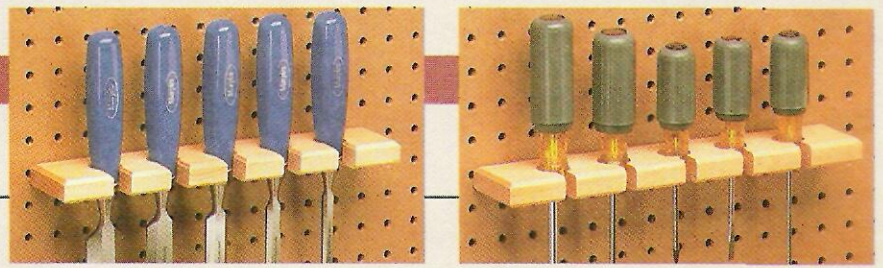

When it comes to storing chisels and screwdrivers, a board with a couple L-hooks is all you need, as you can see in the photos and drawings at right.

You'll notice that these tool holders have narrow slots cut slightly wider than the shank of the tool. This makes it easy to lift the tool slightly and then just pull it out.

Also, when drilling the holes for the chisels, chamfer the top edge so the ferrule slips easily into the hole. And for the screwdrivers, counterbore the holes slightly larger than the handles (see details).

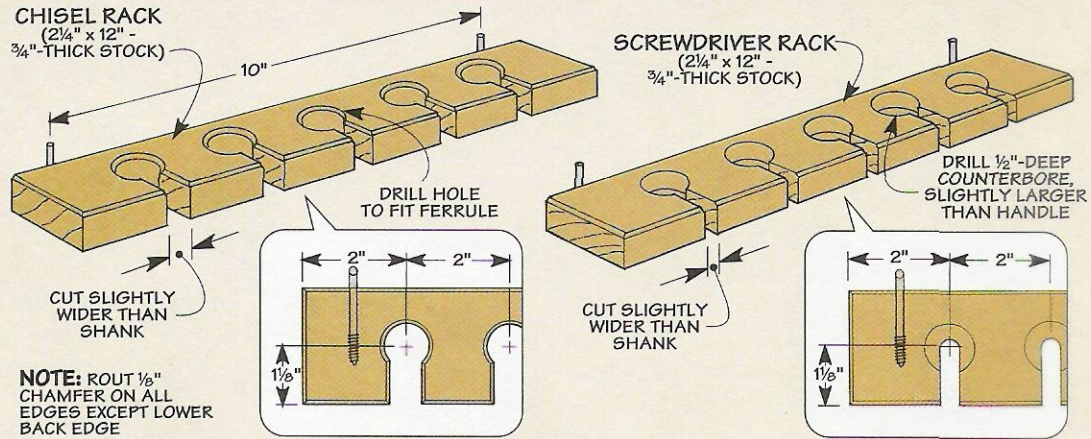

Pull Saws & Squares

If you take a close look at the tool holders shown at right, you'll see they're quite similar to the shelf on the opposite page. They're just smaller, and the shelves are modified for pull saws and squares.

For the pull saws, all that needs to be done is to cut an angled slot for each saw in the shelf. Then just glue the shelf to the back.

The holder for the squares also has slots. But as you can see, these are short kerfs cut in the ends of the shelf for the blade of the square. To keep the squares in place, I cut shallow grooves centered on each slot.

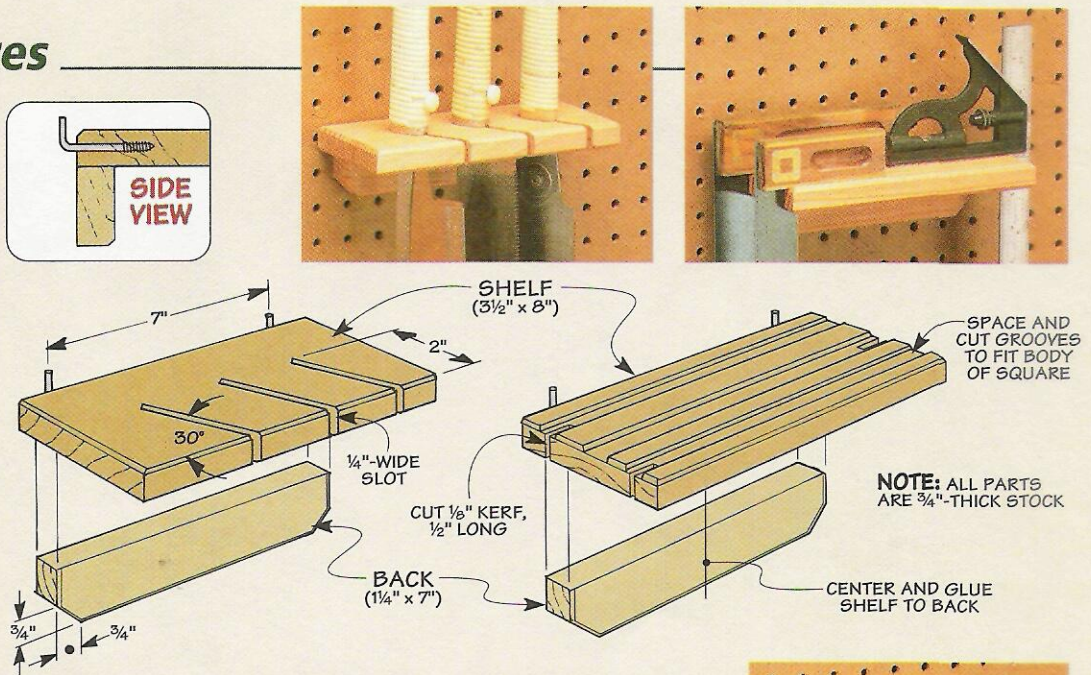

C-Clamps

Storing C-clamps has always been a challenge — until now. The holder shown in the photo and drawing at right lets you slip them on or off without having to open or close the clamps. It consists of a base, a head, and four dowels to hold the clamps.

To prevent the clamps from sliding off the holder, I drilled the holes in the base at an angle (see detail). And to provide plenty of room for the L-hooks to screw into, the head is 2 1/4 inch wide and rabbeted in the back to fit over the the base.

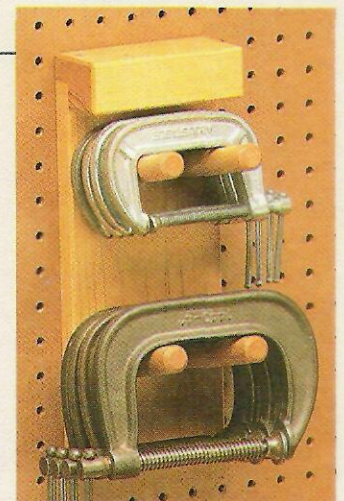
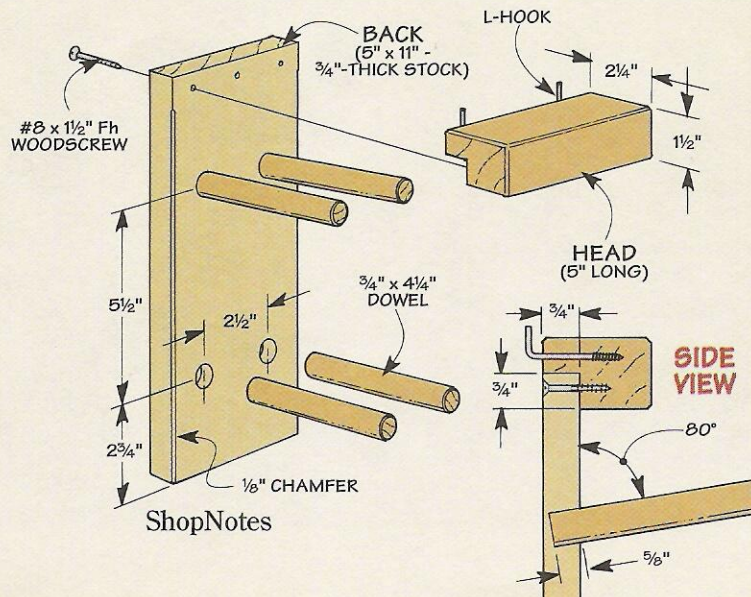

NOTE: CHAMFER ENDS OF EACH DOWEL

Cutting Perfect Half Laps

Four “perfect” reasons. That’s why I used half laps for the doors of the Wall Cabinet on page 22. First, all the stile and rails can be cut to final length, since you don’t have to account for any “joinery.” And a half lap is quick to make because all the workpieces are cut using the same setup. Third, a half lap is a strong joint. That’s because there’s a lot of face-to-face surface for a good glue joint. And finally, the frame practically squares itself when you assemble the joints.

The Keys – There are two keys to cutting a half lap with perfectly smooth joint lines (photo above). The first is to make sure all the workpieces are exactly the same thickness. The other is to set the blade to the proper height — exactly half the thickness of the workpiece.

This sounds easy enough, but getting there can be a bit tricky. So I use a foolproof process that requires nothing more than a table saw, a dado blade, and an auxiliary fence.

Adjust Blade & Fence – To do this, I don’t try to get it right on the first try. Instead, I start with a test piece and set the blade just *under* half the thickness. Then I make two passes, flipping the piece over between passes, to end up with a thin sliver of wood (Step 1 and detail ‘a’).

Now just raise the blade half the height of the sliver and repeat this process until the sliver is just removed. This ensures that once the workpieces are assembled, the joint will be perfectly flush (see photo above). Finally, adjust the rip fence to match the width of the workpiece (Step 2).

Cut & Clean – Now you can cut the half laps on each piece (Step 3). You may notice that the dado blade leaves tiny grooves along the cheeks. To clean them up, slowly move the piece side to side over the blade (Step 4).

Clamp – With all the half laps cut, all that’s left to do is clamp them up. Besides clamping across the frame, it’s also a good idea to clamp each corner to ensure the half laps are tight across the cheeks (Step 5). 🐿

Step-By-Step

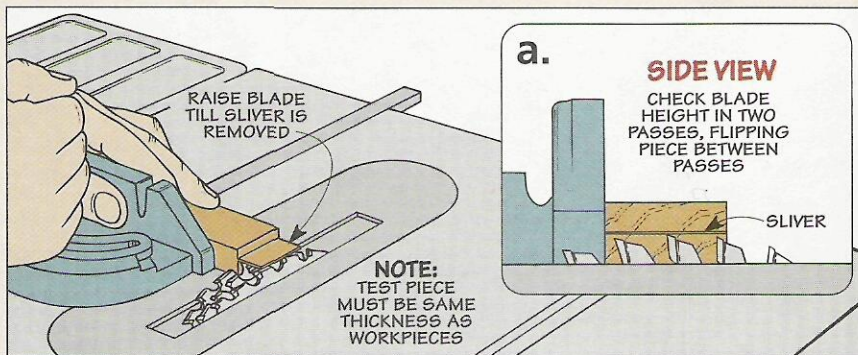

1 With the blade set to just under half the thickness of the workpiece (detail ‘a’), make a pass on each side to leave a sliver of wood. Raise the blade slightly and repeat this process until the sliver is just removed.

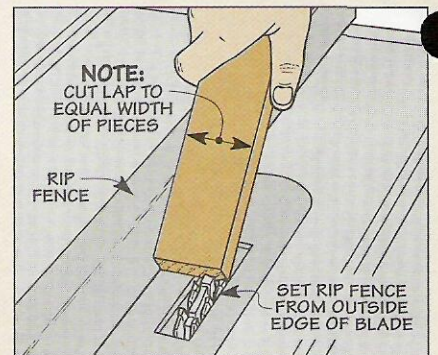

2 Next, set the rip fence so the distance from the outside of the blade equals the width of the workpiece.

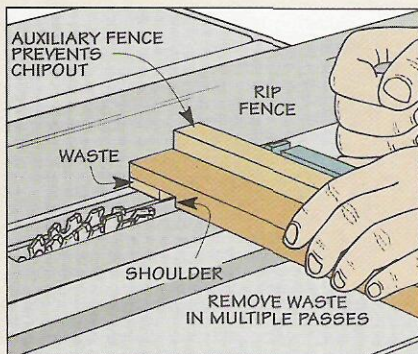

3 Starting with the shoulder, make multiple passes to cut the half lap at the end of each workpiece.

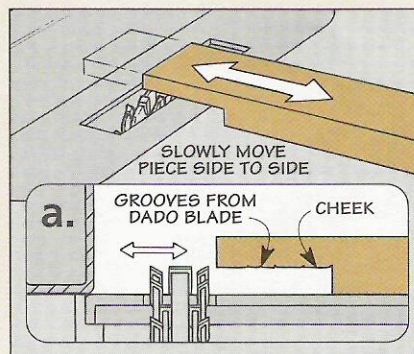

4 To clean up the cheek, push the workpiece over the blade slowly while moving it side to side.

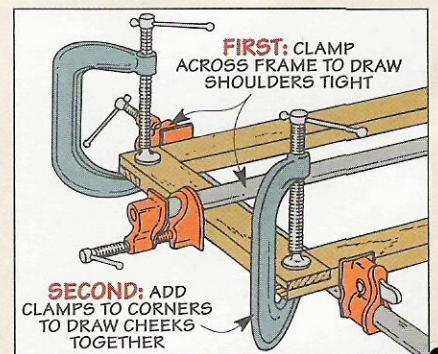

5 After clamping the frame across the width and length, add clamps at each corner of the frame.

Sources

PRODUCT INFORMATION

Pull Saws ▶

Pull saws are available in a variety of styles (and prices) depending upon the kind of wood you will be cutting (hardwood or softwood) and the type of cut you want to make (rip or crosscut). There are also flush cut saws as well as special saws for cutting dovetails. But they all have one thing in common — they all cut on the pull stroke.

Pull saws are available at most woodworking stores or from the sources listed at right.

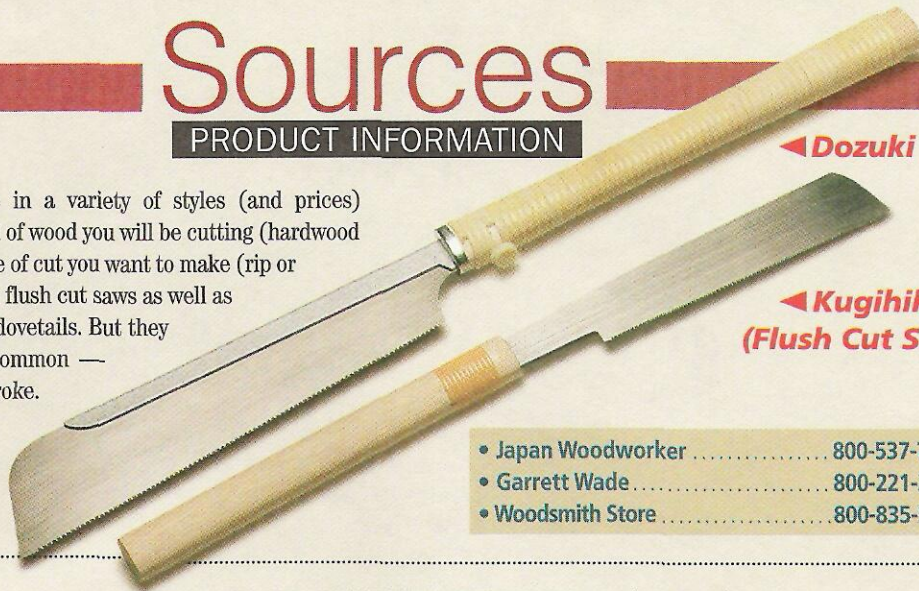

◀ **Dozuki (Backsaw)**

◀ **Kugihiki (Flush Cut Saw)**

- Japan Woodworker 800-537-7820
- Garrett Wade 800-221-2942
- Woodsmith Store 800-835-5084

Door Magnets & Pulls ▶

Most of the hardware used on the wall cabinet can be found at your local hardware store. But a couple of the items are a little harder to track down. The door magnets are available through Lee Valley (800-871-8158). And the cup pulls for the doors can be ordered through D. Lawless Hardware (618-395-3945).



Chalkboard Paint ▶

To make the chalkboard door panel for the wall cabinet on page 22, we used a special spray paint. *Krylon* chalkboard paint sprays on like ordinary paint. But when it's dry, you can write on it with chalk. This paint can be found at hardware stores or home centers.

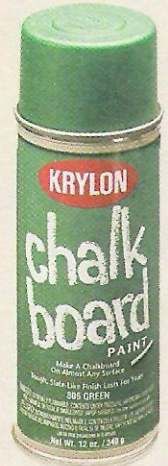

◀ Cabinet Base Levelers

ShopNotes Project Supplies is offering the levelers used on the shop cabinets on page 6. These are heavy-duty levelers that attach to the base and are adjusted with an Allen wrench. (You supply the Allen wrench and mounting screws for the levelers.) To place an order for these levelers, call 1-800-347-5105. Use Key Code SN 59.

Heavy-Duty Base Levelers

1008306..... \$21.95 per pair

Pull Saw Guides ▶

If you've never used a pull saw before, the guides shown here (and on page 17) can really help. The *Veritas* Dovetail Guides (see left photo) come in two "sizes" to cut dovetails with ratios of 1:6 and 1:8 (for softwoods and hardwoods, respectively). Each guide can be purchased individually (\$24.95) or along with the *Veritas* Dovetail Saw (\$35.95).

The *Vaughan* Perfect Free Angle Saw Guide (right photo) will help you cut simple and compound miters with ease. The guide comes packaged with a *Vaughan* Bear Saw and a protractor device to help you set the guide to the correct angles for your cut. The saw and guide package retails for about \$70.00.



- Lee Valley (*Veritas* Dovetail Saw & Guides) 800-871-8158
- Rockler (*Perfect Saw Guide*, Item #26442) 800-279-4441

Scenes from the Shop

This pull saw miter box is ► just the ticket for making clean, precise miter cuts on delicate moldings or small trim pieces. The saw guides are adjustable to match the thickness of your saw blade, resulting in an accurate cut every time. (Plans begin on page 18.)



Inside this wall cabinet is a ► pegboard for hanging a variety of hand tools. On the outside, the sliding doors double as either a handy chalkboard or a magnet board. (Turn to page 22 for instructions on building this wall cabinet.)

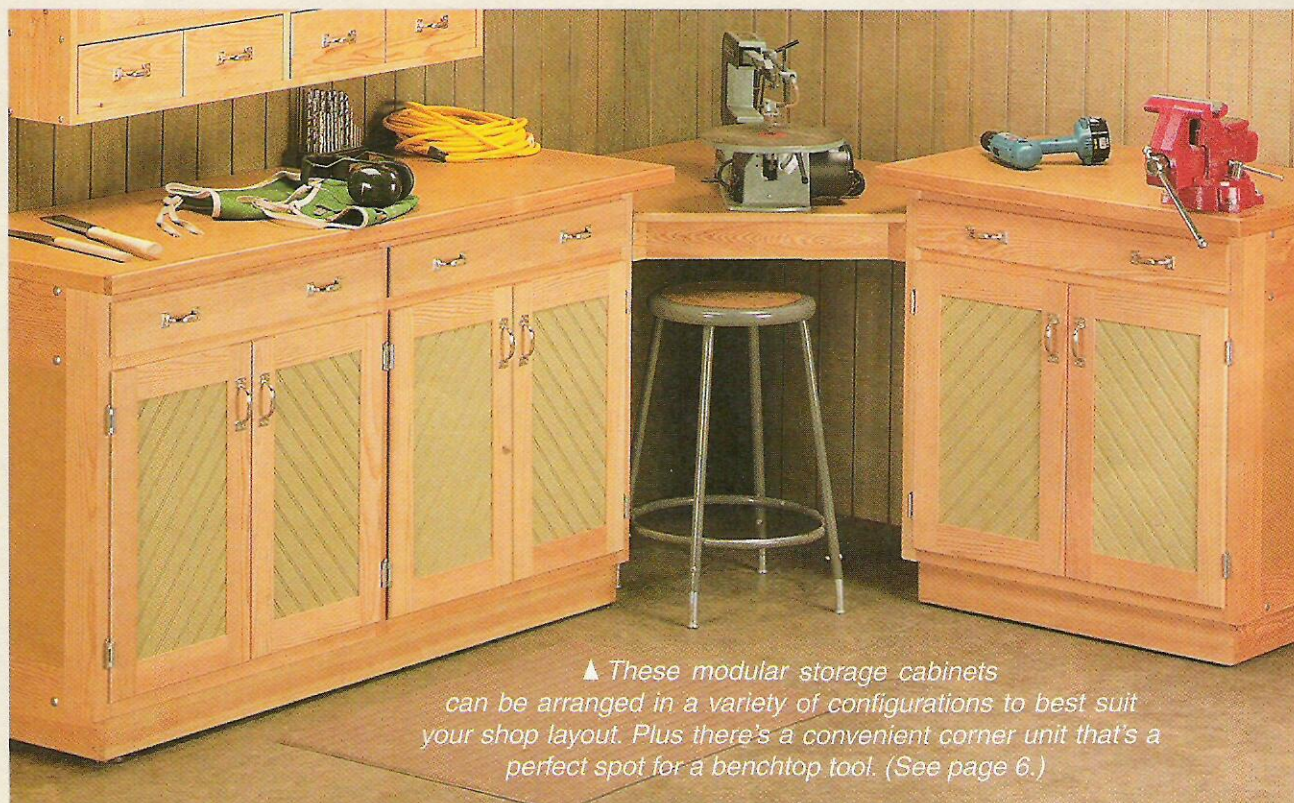
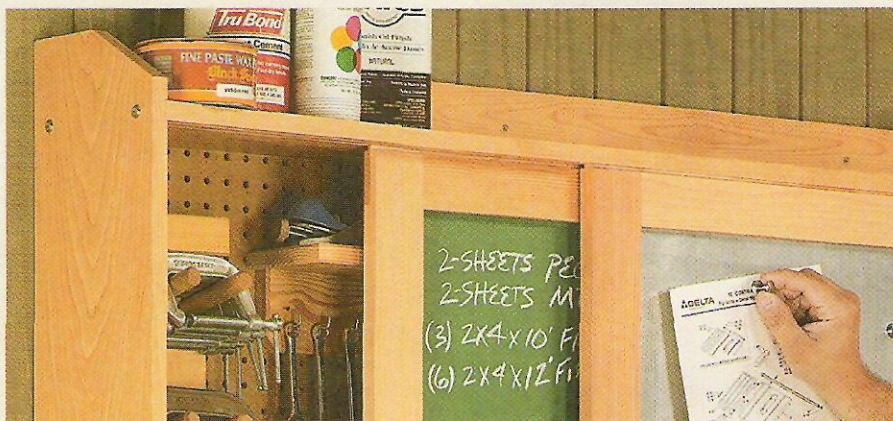

▲ These modular storage cabinets can be arranged in a variety of configurations to best suit your shop layout. Plus there's a convenient corner unit that's a perfect spot for a benchtop tool. (See page 6.)



ShopNotes[®]

Cutting Diagram

Modular Shop Cabinet

Materials (Single Unit)

Case Assembly

A End Frame Stiles (4)	$1\frac{1}{2} \times 3\frac{1}{4} - 31$
B Upper End Rails (2)	$1\frac{1}{2} \times 6\frac{1}{2} - 15$
C Lower End Rails (2)	$1\frac{1}{2} \times 3\frac{1}{4} - 15$
D Web Frame Rails (6)	$1\frac{1}{2} \times 2\frac{1}{2} - 15$
E Web Frame Stiles (6)	$1\frac{1}{2} \times 3\frac{1}{4} - 29$
F End Frame Panels (2)	$15 \times 22\frac{1}{4} - \frac{3}{4}$ MDF
G Back (1)	$23\frac{3}{4} \times 29\frac{3}{4} - \frac{1}{4}$ Hdbd.

Top

H Top Panels (2)	$23\frac{1}{4} \times 33\frac{1}{2} - \frac{3}{4}$ MDF
I Top Edging (1)	$\frac{3}{4} \times 1\frac{1}{2} - 7$ lin. ft.
J Mounting Blocks (4)	$1\frac{1}{2} \times 2\frac{1}{2} - 2\frac{1}{2}$

Base

K Base Front/Back (2)	$1\frac{1}{2} \times 3\frac{1}{2} - 30$
L Base Sides (2)	$1\frac{1}{2} \times 3\frac{1}{2} - 19$
M Bottom Shelf (1)	$19\frac{3}{4} \times 29 - \frac{3}{4}$ MDF

Drawer

N Drawer Front/Back (2)	$\frac{3}{4} \times 3\frac{1}{4} - 27$
O Drawer Sides (2)	$\frac{3}{4} \times 3\frac{1}{4} - 19\frac{3}{4}$
P Drawer Bottom (1)	$18\frac{3}{4} \times 27 - \frac{1}{4}$ Hdbd.
Q Drawer False Front (1)	$\frac{3}{4} \times 4 - 29\frac{1}{2}$
R Center Divider (1)	$\frac{3}{4} \times 2\frac{3}{4} - 18\frac{3}{4}$
S Cross Divider (1)	$\frac{3}{4} \times 2\frac{3}{4} - 13\frac{3}{8}$
T Long Divider (3)	$2\frac{3}{4} \times 18\frac{3}{4} - \frac{1}{4}$ Hdbd.
U Short Dividers (6)	$2\frac{3}{4} \times 9\frac{1}{4} - \frac{1}{4}$ Hdbd.

Tray

V Tray Panel (1)	$19\frac{3}{8} \times 25\frac{3}{4} - \frac{3}{4}$ MDF
W Tray Edging (1)	$\frac{3}{4} \times 2 - 6$ lin. ft.
X Tray Cleats (2)	$\frac{3}{4} \times 2 - 19\frac{3}{4}$

Door

Y Door Rails (4)	$\frac{3}{4} \times 2\frac{1}{2} - 10\frac{1}{2}$
Z Door Stiles (4)	$\frac{3}{4} \times 2\frac{1}{2} - 23\frac{1}{2}$
AA Door Panels (2)	$10\frac{1}{2} \times 19\frac{1}{4} - \frac{1}{4}$ ply.

1½" x 9¼" - 96" TWO BOARDS

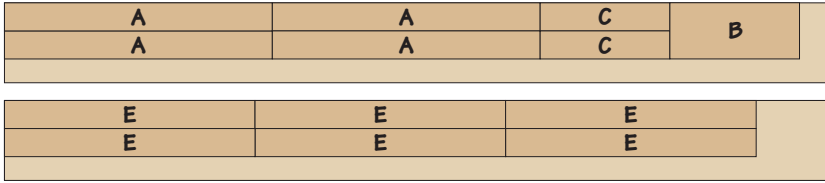

1½" x 9¼" - 72" ONE BOARD



¾" x 7¼" - 72" TWO BOARDS

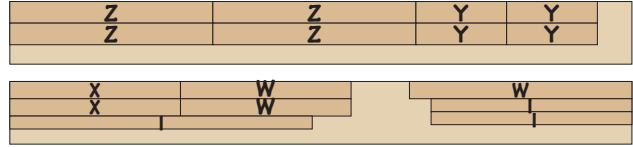

1½" x 5½" - 72" ONE BOARD



¾" x 7¼" - 96" ONE BOARD



¾" MDF - 48" x 96"

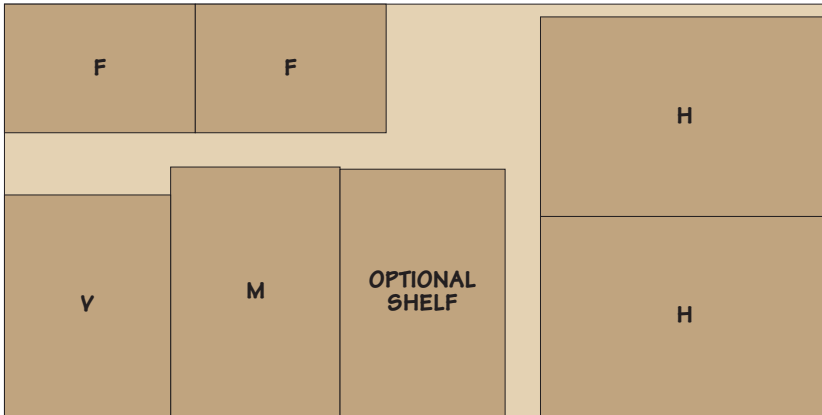

¼" HARDBOARD - 48" x 48"

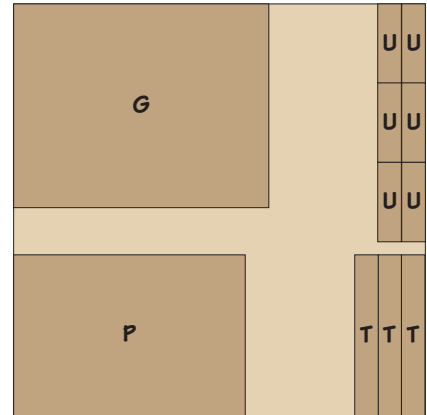

¼" BEAD BOARD - 48" x 96"

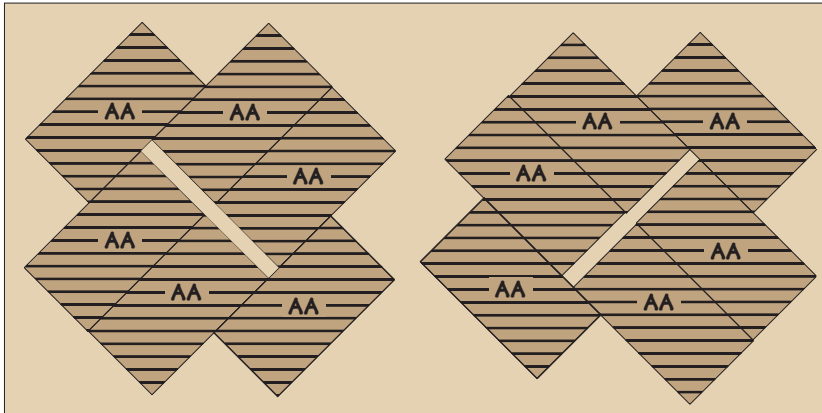

NOTE: ONE 48" x 96" SHEET WILL YIELD ENOUGH DIAGONAL BEADED PANELS FOR SIX CABINETS

Wall Cabinet

Materials

Case

A Sides (2)	$\frac{3}{4}$ x $7\frac{1}{2}$ - 38
B Top, Middle, & Btm. Shelves (3)	$\frac{3}{4}$ x $7\frac{1}{2}$ - $46\frac{3}{4}$
C Back (1)	$28\frac{1}{4}$ x $47\frac{1}{4}$ - $\frac{1}{4}$ Pgbd.
D Lower Rail (1)	$\frac{3}{4}$ x $5\frac{1}{4}$ - $47\frac{1}{4}$
E Upper Rail (1)	$\frac{3}{4}$ x 3 - $47\frac{1}{4}$
F Divider (1)	$\frac{3}{4}$ x $6\frac{3}{4}$ - $5\frac{1}{2}$

Drawers

G Drawer Fronts/Backs (8)	$\frac{3}{4}$ x $5\frac{1}{8}$ - $11\frac{1}{4}$
H Drawer Bottoms (4)	$\frac{3}{4}$ x $6\frac{1}{4}$ - $10\frac{3}{4}$
I Drawer Sides (8)	$5\frac{1}{8}$ x $6\frac{1}{4}$ - $\frac{1}{4}$ Hdbd.

Doors

J Door Stiles (4)	$\frac{3}{4}$ x $2\frac{1}{2}$ - $27\frac{7}{8}$
K Door Rails (4)	$\frac{3}{4}$ x $2\frac{1}{2}$ - $24\frac{1}{2}$
L Door Panels (2)	$20\frac{1}{4}$ x $23\frac{5}{8}$ - $\frac{1}{4}$ Hdbd.

$\frac{3}{4}$ " x $9\frac{1}{4}$ " - 96" FIVE BOARDS

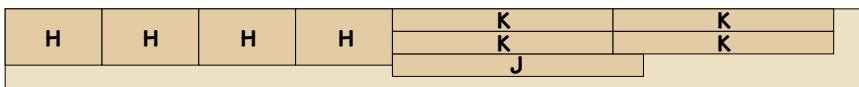
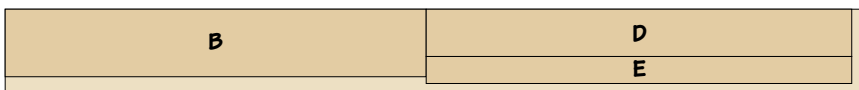
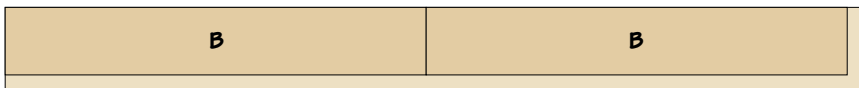

$\frac{1}{4}$ " PEGBOARD - 48" x 48"

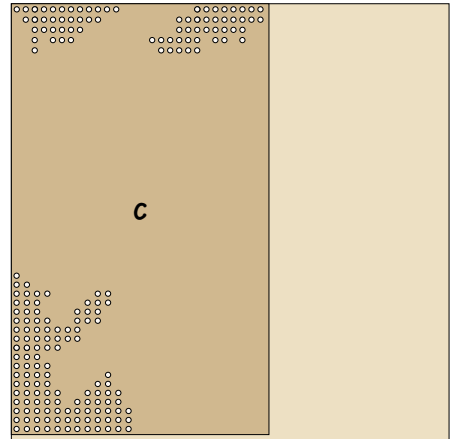

$\frac{1}{4}$ " HARDBOARD - 48" x 48"

