

Handy
5 in 1
Router System

SPECIAL ANNIVERSARY ISSUE

ShopNotes®

Vol. 11

Issue 61

Razor Sharp in Record Time

DRILL PRESS SHARPENING WHEEL



◆ **Brad Nailers:**
*Why every shop
should have one*

◆ **Adjustable Hand Plane:**
*All-new design that
works as good as it looks*

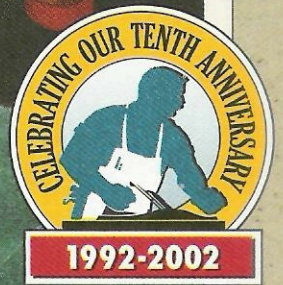



ShopNotes®

Issue 61

January 2002

PUBLISHER Donald B. Peschke

EDITOR Terry J. Strohman

ASSOCIATE EDITORS Bryan Nelson
Vincent Ancona

CONTRIBUTING EDITORS Joel Hess
Craig Ruegsegger

ART DIRECTOR Cary Christensen

SR. GRAPHIC DESIGNER Kurt Schultz

SENIOR ILLUSTRATORS Roger Reiland
Mark Higdon

CREATIVE RESOURCES

Creative Director: Ted Kralicek • *Project Developer:* Ken Munkel
• *Project Designers:* Chris Glowacki, Craig Iseke • *Shop Craftsmen:*
Steve Curtis, Steve Johnson • *Senior Photographer:* Crayola England

SPECIAL PUBLICATIONS

Corp. V.P.: Douglas L. Hicks • *Art Director:* Douglas A. Flint • *Sr. Graphic Designer:* Chris Glowacki • *Graphic Designer:* Vu Nguyen • *Associate Editor:* Craig Ruegsegger • *Asst. Editors:* Joel A. Hess, Joseph E. Irwin

CIRCULATION

Subscriber Services Director: Sandy Baum • *New Business Dir.:* Wayde J. Klingbeil • *Circulation Marketing Analyst:* Kris Schlemmer • *Assoc. Circ. Marketing Analyst:* Paula DeMatteis • *Renewal Manager:* Paige Rogers • *Sr. Graphic Designers:* Mark Hayes, Robin Friend • *Billing & Collections Mgr.:* Rebecca Cunningham • *Multimedia Promotion Mgr.:* Rick Junkins • *Promotion Analyst:* Patrick Walsh

CORPORATE SERVICES

V.P. of Finance: Mary Scheve • *Controller:* Robin Hutchinson • *Sr. Acct.:* Laura Thomas • *Accts. Payable:* Mary Schultz • *Accts. Receivable:* Margo Petrus • *Prod. Dir.:* George Chmielarz • *Electronic Pub. Dir.:* Douglas M. Lidster • *Network Admin.:* Cris Schwanebeck • *P.C. Maint. Tech.:* Rob Cook • *Pre-Press Image Specialists:* Troy Clark, Minniette Johnson • *Office Mgr.:* Noelle Carroll • *New Media Mgr.:* Gordon C. Gaippe • *Multimedia Art Dir.:* Eugene Pedersen • *Web Server Admin.:* Carol Schoeppler • *Web Content Mgrs.:* David Briggs, Sue M. Moe • *Web Designer:* Kara Blessing • *Prof. Dev. Dir.:* Michal Sigel • *H. R. Asst.:* Kirsten Koele • *Receptionist:* Jeanne Johnson • *Mail Room Clerk:* Lou Webber

MAIL ORDER

Operations Director: Bob Baker • *Customer Service Mgr.:* Jennie Enos • *Warehouse Supr.:* Nancy Johnson • *Buyer:* Linda Jones • *Admin. Asst.:* Nancy Downey • *Tech. Rep.:* John Audette • *Cust. Serv. Team Leader:* Tammy Truckenbrod • *Sr. Cust. Serv. Reps.:* Anna Cox, Deborah Rich • *Cust. Serv. Reps.:* April Revell, Valerie Riley, Eddie Arthur • *Warehouse:* Sylvia Carey, Dan Spidle, Sheryl Knox

WOODSMITH STORE

Manager: Dave Larson • *Asst. Mgr.:* Tim Thelen • *Sales Staff:* Wendell Stone, Jim Barnett, Larry Morrison, Gregory Kauzlarich, Mark Johnson, Joe Kucera • *Office Mgr.:* Vicki Edwards

ShopNotes® (ISSN 1062-9696) is published bimonthly (Jan., March, May, July, Sept., Nov.) by August Home Publishing, 2200 Grand, Des Moines, IA 50312.

ShopNotes® is a registered trademark of August Home Publishing © Copyright 2002 by August Home Publishing. All rights reserved. Subscriptions: Single copy: \$4.95. One year subscription (6 issues), \$27.95. Canada/International add \$10 per year, U.S. funds. Periodicals Postage Paid at Des Moines, IA and at additional mailing offices.

Postmaster: Send change of address to ShopNotes, P.O. Box 37103, Boone, IA 50037-2103.

Subscription Questions? Write to: ShopNotes Customer Service, P.O. Box 842, Des Moines, IA 50304-9961. Or call 1-800-333-5854, 8:00 am to 5:00 pm, Central Time, weekdays. FAX 515-283-0447

E-Mail: ShopNotes@shopnotes.com
Internet: http://www.shopnotes.com

PRINTED IN U.S.A.

EDITOR'S NOTE

Cutoffs

It's hard for me to believe, but it's been ten years since the first issue of *ShopNotes* went out. I had the privilege of being a part of that first issue. And I know that many of you have also been with us since the beginning. To help celebrate this special event, we've decided to give something back to our long-time subscribers and to our new subscribers as well.

More pages – For the last ten years *ShopNotes* has been a 32-page magazine. But starting with this issue, that's changing — we're adding four more pages. And we're increasing the quality of the paper those pages are printed on. Now each issue will have a tough, heavy-duty front and back cover.

Of course this also means we will be able to present you with more information. And we're going to start off by adding two new departments — Shop Talk and Tool Chest.

Shop Talk – The idea behind this department is simple. We want to provide as many answers to woodworking questions as possible and share with you even more in-depth information and tips from our shop.

In this issue we take a look at the difference between right- and left-tilt table saws and how it may affect your woodworking.

Tool Chest – Our second new department is Tool Chest. In this department we'll introduce you to some of our favorite tools. Sometimes they'll be tools we've used for years. Other times they'll be brand new. Whatever the case, these tools have proven their worth in our shop.

And don't think that a tool has to be expensive to be a top performer. In this issue we're featuring great scrapers that cost less than \$20.

Woodsmith Tours – Speaking of new, we're offering an exciting opportunity for woodworkers that like to travel: A special tour that will take you behind the scenes in American woodworking shops, tool factories, and historic sites. For more information, call Linda at 800-333-5441 extension 7241 or visit our website:

www.WoodsmithTours.com

Terry

Be included, as a part of the Woodworking Shop Tours

On the Web

Visit other *ShopNotes* subscribers' workshops and see photos of the shop projects they've built. It's all online at Woodworking Shop Tours on the *ShopNotes* web site:

www.ShopNotes.com

We want you to be part of our shop tours! To submit photos of your favorite *ShopNotes* projects or views of your shop, just follow the instructions you'll find on our web site.



Contents

Features

5-in-1 Router Base Plate System _____ 6

A unique router base plate system makes it easy to use a number of shop-built accessories — mortising jig, circle cutter, flush trim jig, edge guide, and benchtop fence and table.

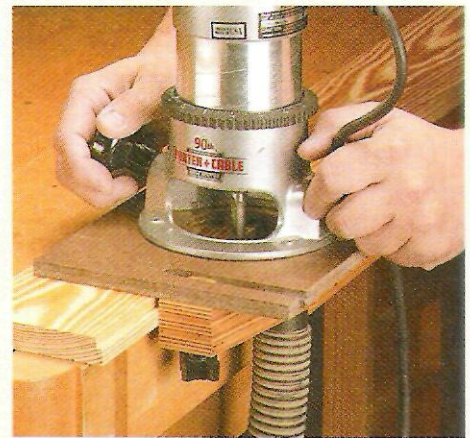

5-in-1 Router System page 6

Brad Nailers _____ 14

A brad nailer can now be standard equipment for every workshop. We'll give you the reasons why and the features to look for when selecting one for your shop.



Brad Nailers page 14

Drill Press Sharpening Wheel _____ 18

Use the low speed of your drill press to sharpen a plane iron or chisel in minutes. Plus, this sharpening wheel features a leather top for honing a razor sharp edge.

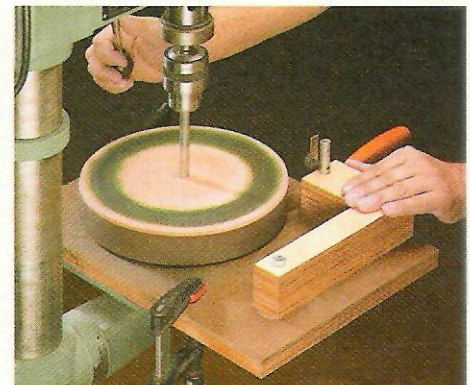

Sharpening Wheel page 18

Tapping Threads _____ 25

A jig, fixture, or tool will often work better and more accurately by tapping the metal parts to accept threaded fasteners. Here's what you need to know about tapping threads.

Adjustable Hand Plane _____ 26

The look and feel of a traditional wood plane with some of the easy-to-use features you find on a metal plane: an adjustable throat opening and a secure blade-mounting system.



Adjustable Hand Plane page 26

Departments

Readers' Tips _____ 4

Shop-tested tips to solve common woodworking problems.

NEW Shop Talk _____ 32

We take on the left or right tilt debate. When it comes to table saws, is one really better than the other?

NEW Tool Chest _____ 34

In this new department, we take a look at tools we use day in and day out. First up — Sandvik scrapers.

Sources _____ 35

Mail-order sources and supplies to help you build the projects featured in this issue.

Readers' Tips

Clamping Jig for Panel Doors

Free Tips ON THE WEB

Get more wood-working tips free.

Visit us on the Web at ShopNotes.com

Sign up to receive a free shop tip by email every week.

■ When I decided to build a set of kitchen cabinets, I had to make and assemble about three dozen raised panel doors. Instead of using pipe or bar clamps for this task, I came up with my own clamping jig, see photo. This jig applies even pressure along the edges of the door and helps to keep it flat. And even though I used it for gluing up doors, it works just as well for gluing up flat panels.

The jig relies on wedges for clamping pressure. The door (or panel) is trapped between a couple of pivoting arms. Then wedges are driven in between the arms and a couple of dowel pins creating a tight, even grip on the workpiece.

As you can see in the drawing below, there's not really much to the

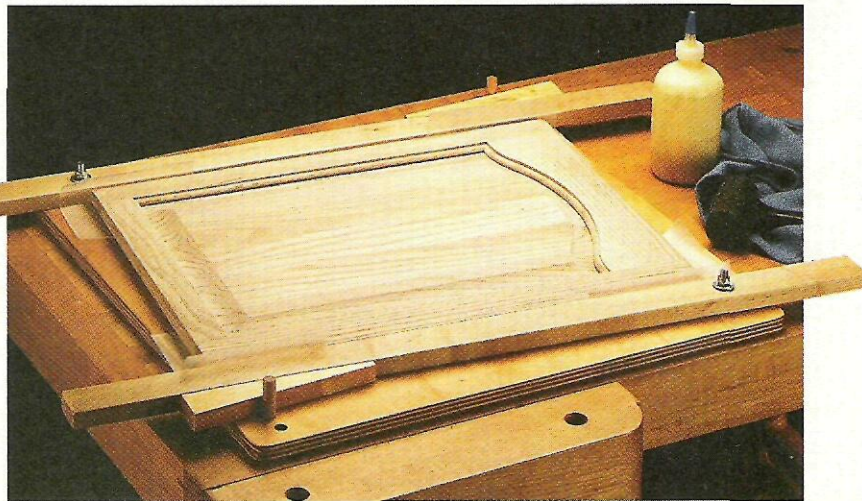

jig. Start by cutting out a square piece of plywood for the base. Then drill a row of holes along two edges of the jig, starting in opposite corners. (These will be for the dowel

pins.) Next, drill a single, counter-bored hole in each of the other two corners for the carriage bolts used to attach the arms, as shown in the detail drawing below.

The arms are cut from narrow pieces of hardwood stock. After drilling a hole near one end of each arm, they can be attached to the base of the jig with carriage bolts, washers, and nylon lock nuts.

Before you can use the jig, you'll also need to make a couple of hardwood wedges and a pair of dowel pins. The wedges can be cut on a table saw or band saw and the pins are simply cut from a hardwood dowel and then sanded lightly until they easily fit into the holes of the jig.

To use the jig, place the door on the base and adjust the dowel pins to position the jaws as close as possible to the edges of the door while still allowing room for the wedges. Then insert the wedges and tap them in tightly with a mallet. You can use wax paper underneath the door to avoid accidentally gluing it to the jig. After the glue is dry, just tap out the wedges and remove the door.

*Edwin C. Hackleman
Omaha, Nebraska*

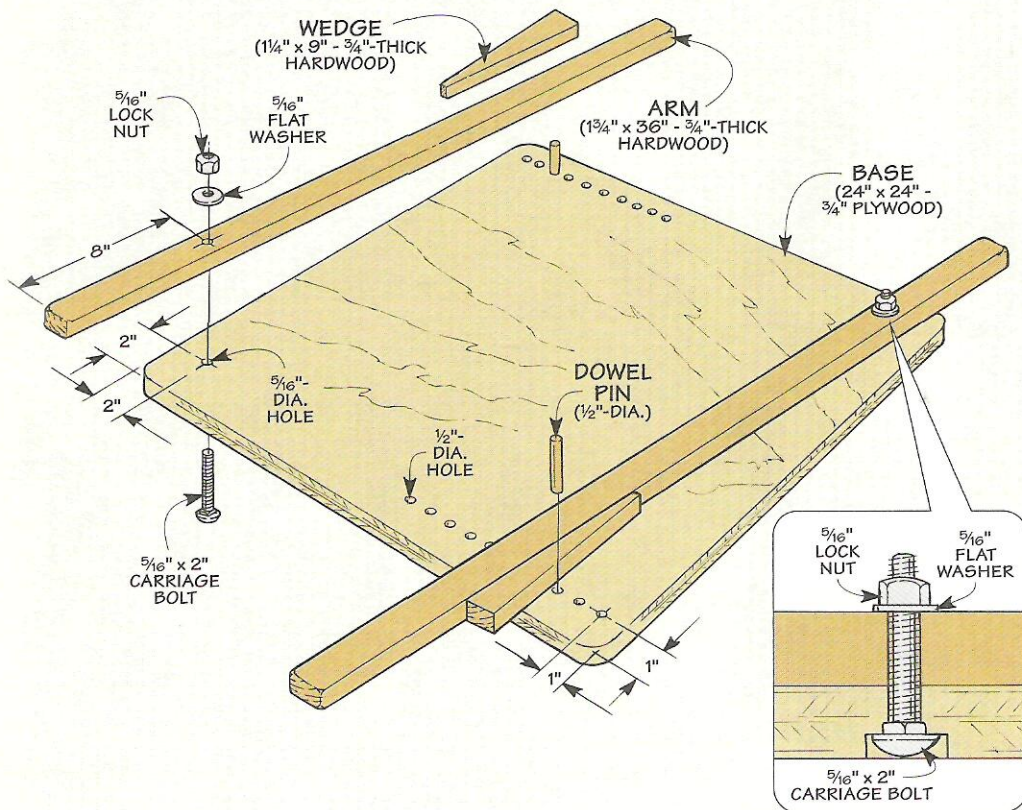

Quick Tips

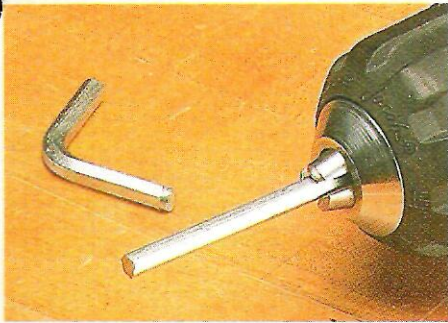

▲ **Tim Schoppert**, of Lexington Park, MD, makes a quick and easy driver bit for Allen head screws by simply cutting off the short leg of an Allen wrench.

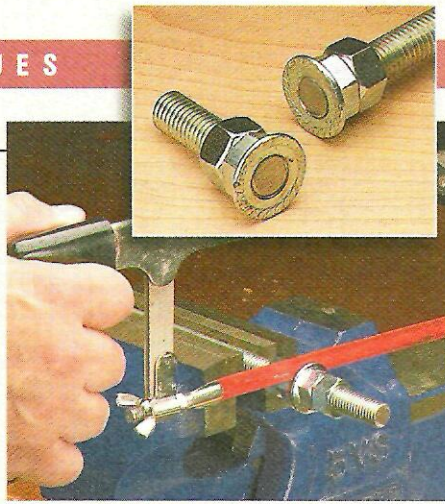

▲ To help guide his hack saw blade when cutting threaded rod, **Dana Craig**, of Norwood, MA, uses a pair of flange nuts backed up by a couple of hex nuts.



◀ To remove a wood plug, **Eli M. Byler**, of New Wilmington, PA, drives a screw through the plug until it hits the screw below and pulls out the plug like a cork.

Glue Bottle Holder

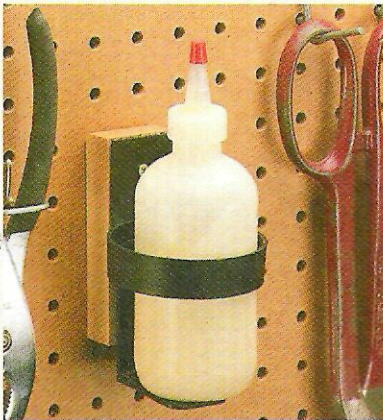

■ I always seem to be forgetting where I set my glue bottle down last. So I came up with a quick and inexpensive solution. I took a plastic coffee cup holder (the kind that fits over your car door) and mounted it to a block of wood. A couple of L-hooks allow you to hang the holder on a piece of pegboard. It also works great for holding a can of soda pop so you don't spill it on your workbench.

*Brad Ocock
Lakeland, Florida*

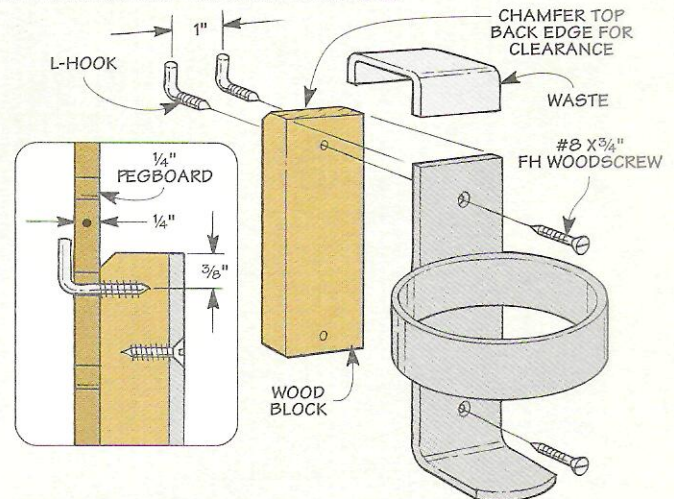

Edge Trimming

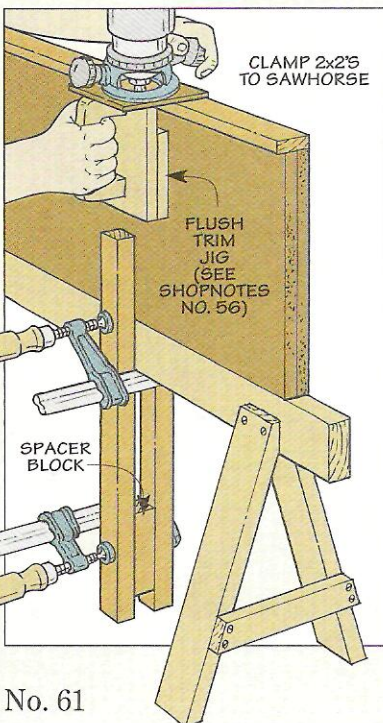

■ I built the flush trim router jig you featured in issue No. 56 and it works great. The only problem I had was supporting my workpieces while using the jig. I had some large table tops that were too big to clamp in my vise or to my workbench. So I came up with another method.

I simply clamped a couple of 2x2's vertically to my sawhorse. Then I set the workpiece on edge on the sawhorse, in between the upright 2x2's. (You can add an extra clamp if needed.) To equalize the clamping pressure, I clamped a spacer block in between the 2x2's, near the floor. And for long pieces, I set up a sawhorse at each end of the workpiece.

Setting the workpieces on sawhorses (rather than on a workbench)

also puts them at a much more convenient working height for trimming the edging flush with the router.

*Gil Strubel
Hagerstown, Maryland*

Send in Your Shop Tips

If you have a unique shop tip, we'd like to consider featuring it in one or more of our print or electronic publications.

We'll pay up to \$200 for a tip we publish. Just write down the tip and mail it to *ShopNotes*, Attn.: Readers' Tips, 2200 Grand Ave., Des Moines, IA 50312. Or FAX it to 515-282-6741, or send us an e-mail at shopnotes@shopnotes.com. Please include your name, address and daytime phone number in case we have any questions.

5 in 1 Router Base Plate System

An assortment of jigs and fixtures to help make your router more versatile and enjoyable to use.

In the last ten years, we've featured a lot of router jigs in *ShopNotes*. So what makes the jigs pictured here different from the others? Well they aren't just jigs. Instead, they're part of a whole router system. The idea is pretty simple. You start by making a replacement base plate for your router. This base plate is pretty handy in itself. Its large surface gives you a lot more support than the plate that comes with your router. And since it has straight sides, it's tracks better along a fence.

But the base plate's real function is to serve as the platform for the router system. An assortment of five different jigs can be built — all of which attach directly to the base plate. Attaching one of the jigs is simply a matter of tightening a couple of knobs. And the jigs allow you to perform a variety of routing tasks, from flush trimming edging to creating mortises (see the photos above and below). There's even a pint-sized router table and fence that can be set up quickly on top of a table or workbench for small routing tasks.

One other benefit of this project is the fact that you won't have to invest a whole lot in the way of time or materials. Aside from some knobs and a few pieces of hardware, the jigs can be built almost entirely from scraps of plywood and hardboard.

BASE PLATE

Since the base plate is the heart of the system, it makes sense to build it first. As you can see in Figure 1, the base

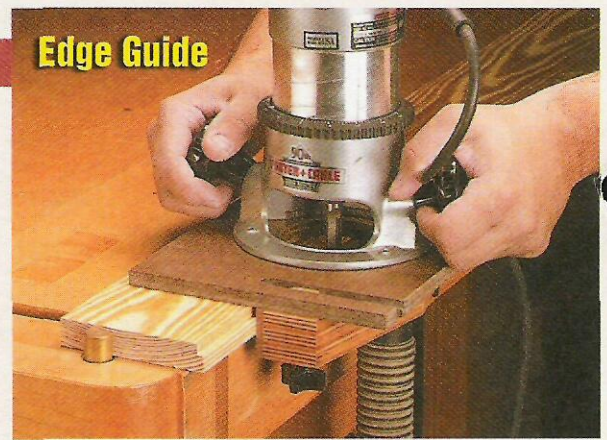

Edge Guide

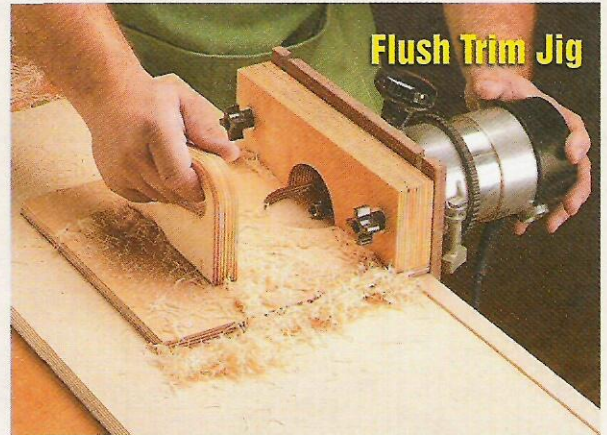

Flush Trim Jig

plate is just a couple of pieces of 1/4" hardboard that are laminated together. You can start by cutting these two plates (A) to identical size. But before gluing the plates together, you'll need to do some routing and drilling.

T-Slots – The router jigs will be attached to the base plate using toilet bolts and T-slots. These slots are created by routing a wide slot in the upper plate and a narrow slot in the lower plate. When the plates are sandwiched together, the result is a T-slot that's sized to hold the head of a T-bolt, see photo in margin on opposite page. In order for this technique to work, the slots have to be carefully positioned on the plates. Although there are several ways to do this, I opted to cut the slots on a router table, using a fence and stop block to position each

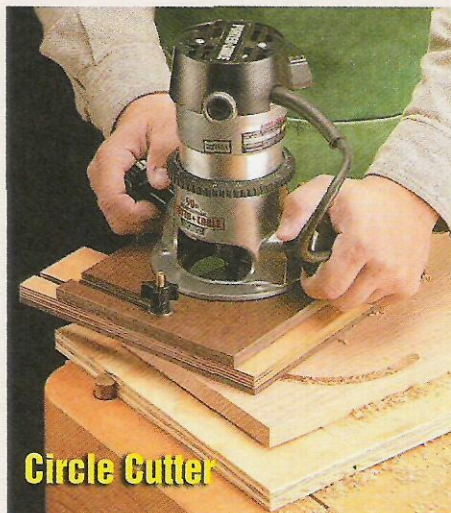

Circle Cutter

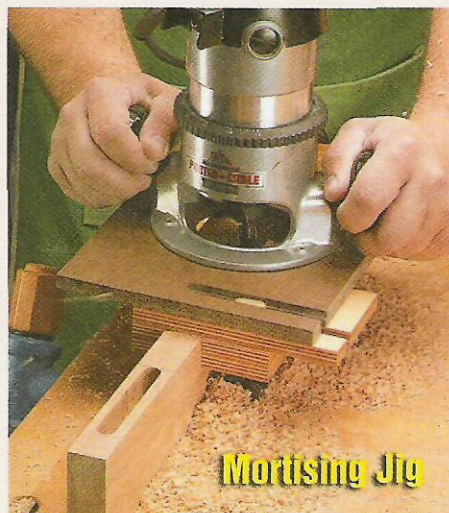

Mortising Jig

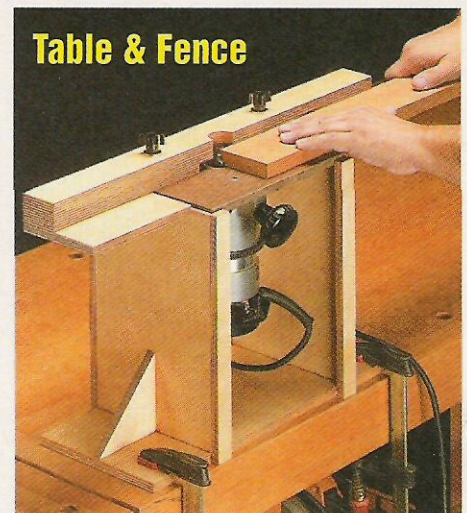

Table & Fence

slot, like you see in Figure 2.

The nice thing about using the router table is that I only had one setup to make. Once the fence and stop block are in position, you can rout the narrow slots in the lower plate. (Just flip the plate over to rout a slot on each side.) Then, without moving the fence or stop block, I changed over to a 1/2"-dia. straight bit and routed the slots in the upper plate. (I used this same technique for making the slots on some of the other jigs as well.)

Insert Opening – In addition to the T-slots, the completed base plate also has a stepped opening for an insert ring (refer to page 13). Like the T-slots, making the opening is a two-step procedure. But this time, I used the drill press rather than the router table. After locating the centerpoint of each plate, a 3 1/2"-dia. hole is drilled through the center of the lower plate, and a 3"-dia. hole is drilled in the upper plate. (I used a wing cutter to make these holes.)

Assembly – Once the holes have



been drilled, the two plates can be glued together. Just make sure the edges of the plates are flush as they are glued up.

After the glue is dry, you can drill the countersunk holes for the screws that will be used to attach the base plate to your router. To do this, I simply removed the factory base plate from my router and used it as a template for drilling the mounting holes, as shown in Figure 3a.

There's just one thing to keep in mind when doing this. You'll need to pay attention to the orientation of the router. The router should be mounted to the base plate so that the handles are parallel with the slots. This way, the knobs that will be used to attach jigs to the base plate won't interfere with the router handles.

When the holes are drilled and countersunk, you can attach the base plate to your router. Because this base plate is thicker than the one that comes with most routers, you may need to swap out the original screws with some longer ones.

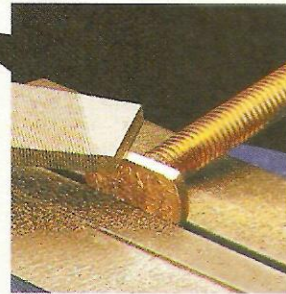

▲ **T-Bolts.** Lightly file down the sides of the toilet bolts so they slide smoothly in the slots.

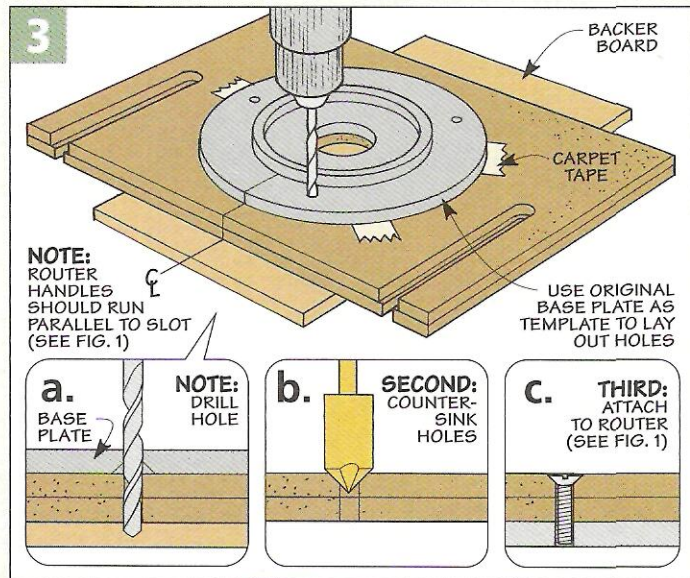
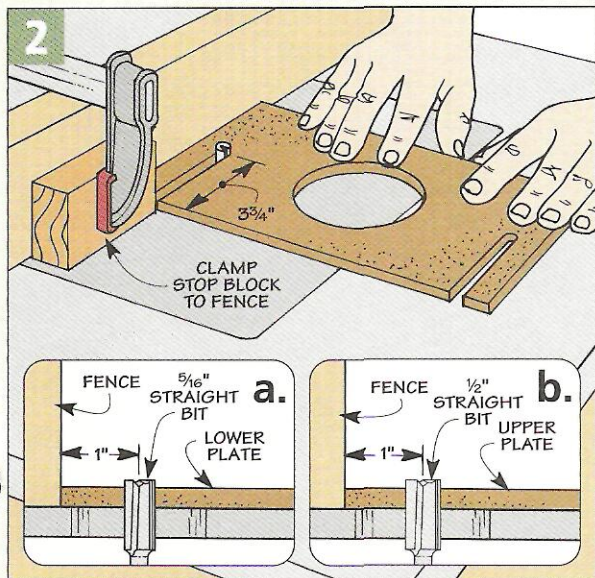
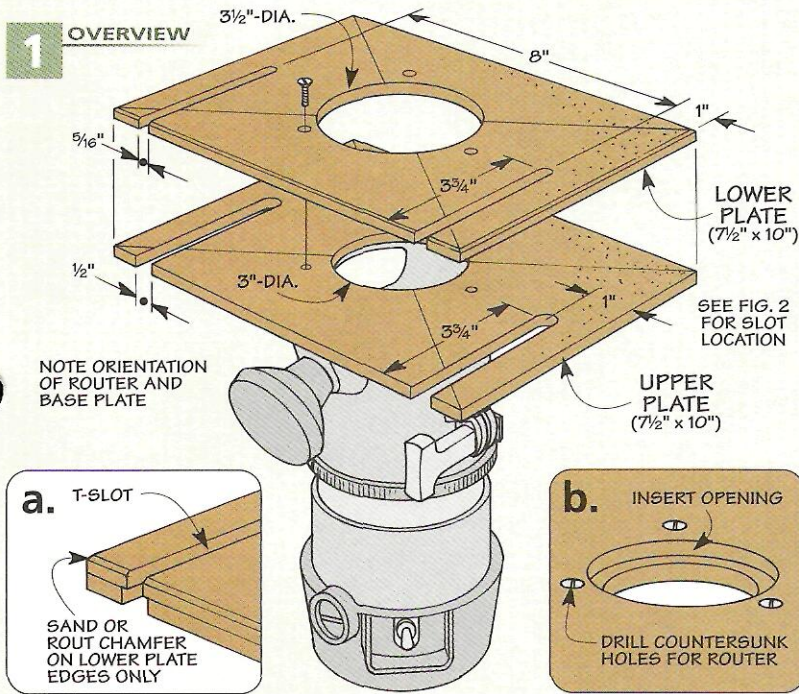

Mortising Jig

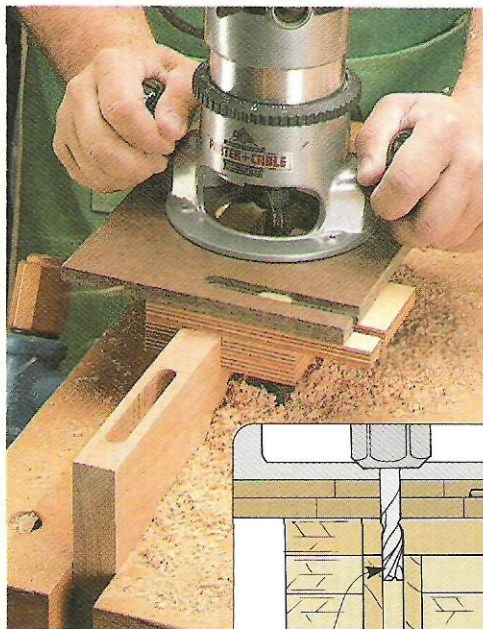

1 OVERVIEW

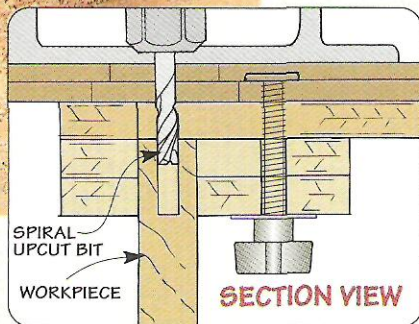
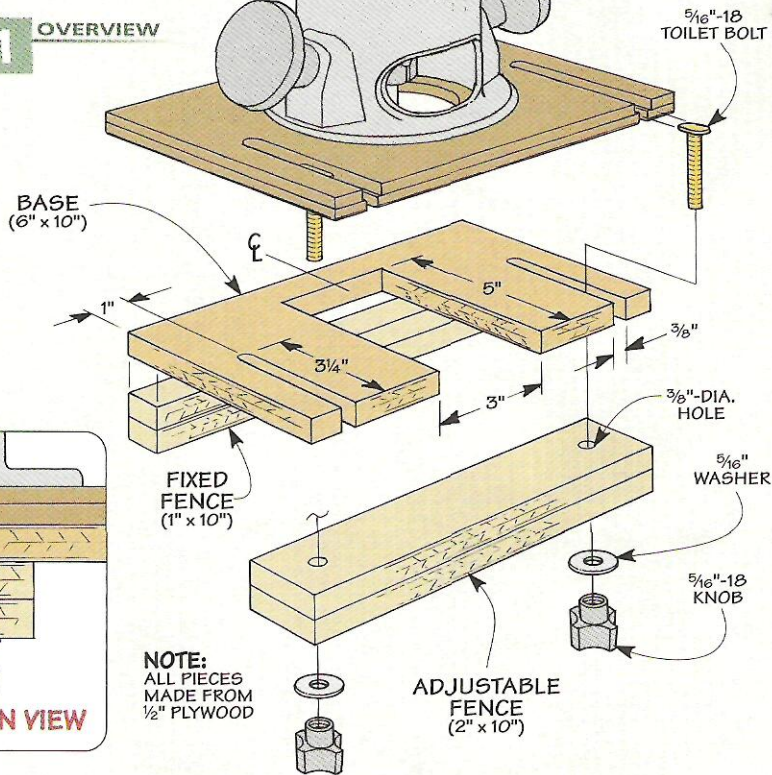

NOTE:
ALL PIECES
MADE FROM
1/2" PLYWOOD

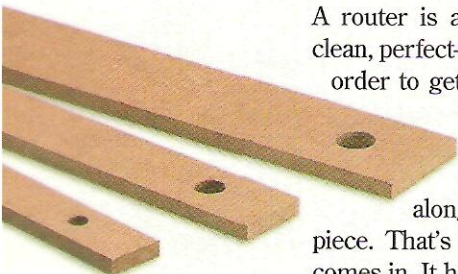

▲ **Gauges.** These set-up gauges make it a snap to adjust the jig for making different sizes of mortises.

A router is a great way to create clean, perfect-fitting mortises. But in order to get the best results, you need a mortising jig to guide the router in a straight path along the edge of the workpiece. That's where this router jig comes in. It has a pair of fences that straddle the workpiece and guide the bit in a straight line. And the jig is adjustable to allow for workpieces of varying thicknesses.

There are only three parts to this jig. The *base* is cut from a piece of 1/2" plywood. It has a slot at each end and a large, rectangular opening in between, as shown in Figure 1.

A *fixed fence* is glued up from two strips of 1/2" plywood and is then glued flush with the back edge of the base. The *adjustable fence* is a bit wider than the fixed fence, but it has a hole drilled at each end for a toilet bolt.

The mortising jig is mounted to the router base plate using a couple of toilet bolts, washers, and a pair of threaded knobs. The toilet bolts fit into the T-slots in the base plate and pass through the slots in the base of the mortising jig and the holes in the adjustable fence.

Set-Up Gauge – To help center the router bit between the two fences of the jig, I use a simple set-up

gauge. This is just a narrow piece of hardboard that is cut to match the thickness of the workpiece you are mortising. In the center of this strip of hardboard, a hole is drilled that matches the diameter of your router bit. Now just slip the gauge over your router bit and adjust the fences so the gauge is sandwiched in between them (Figure 2).

Once the jig is set up, you can start routing your mortises. With the router running, slowly lower the router and jig down over your workpiece, plunging the bit into the area you've marked out for your mortise. Then rout the slot. I try not to remove more than a 1/4" of material at a time. For deeper mortises, you need to make multiple passes, lowering the router bit after each one.

One last thing. Although you can use a straight bit for routing mortises, I prefer to use a spiral upcut bit. The nice thing about these bits is that their spiral design pulls the chips up out of the mortise, giving you a cleaner cut and making it easier to see what you are doing. (See page 35 for sources.)

2 FIGURE

FIRST: PLACE SET-UP GAUGE OVER ROUTER BIT

SECOND: SLIDE FIXED FENCE AGAINST SET-UP GAUGE

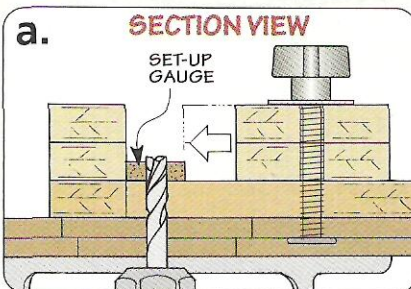
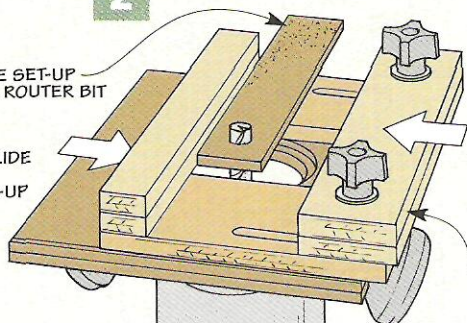

THIRD: SLIDE ADJUSTABLE FENCE AGAINST SET-UP GAUGE AND TIGHTEN KNOBS

Flush Trim Jig

Whenever I make a furniture project out of plywood, I usually add hardwood edging to any exposed plywood edges. And it's almost always easier to make this edging wider than necessary and then trim it flush with the plywood after it has been applied. A router and a flush trim bit makes this a little easier, but it's still difficult to balance the router on the edge of the panel you are trimming. That's because there isn't usually enough surface for the router to rest on comfortably.

With this flush trim jig, the support surface for the router is "built-in." The base of the jig provides a wide, flat surface that rides against the side of the panel that you are flush trimming. This makes it a lot easier to hold the router steady.

I made the flush trim jig by cutting a *base* out of 1/2" plywood. A large opening is cut on one side of the base to provide clearance for the flush trim bit, as shown in Figure 1. A sabre saw or band saw can be used to cut this opening, and then the edges can be sanded smooth with a drum sander.

Mounting Block – In order to attach the router to the jig, a *mounting block* is added to the base of the jig. This block is glued up out of three layers of 1/2" plywood. After these pieces are glued together, a 3/8"-dia. mounting hole is drilled at each end. Then a semi-circular opening is cut out of the middle of the fence and sanded smooth. The mounting block is glued to the base, flush with the edge.

Handle – To make it easier to get a grip on the jig, a *handle* is added to the base. It's made from two layers of 1/2" plywood. The pattern for this handle is shown in Figure 1. To create the opening for the handle, a hole is drilled at each end of the opening. Then the waste in between the holes is cut away with a sabre saw. Once this is done, the inside edges can be sanded smooth. Finally, to make the handle more comfortable to grasp, all the exposed

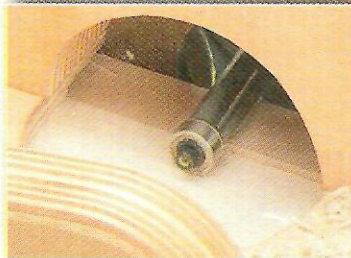
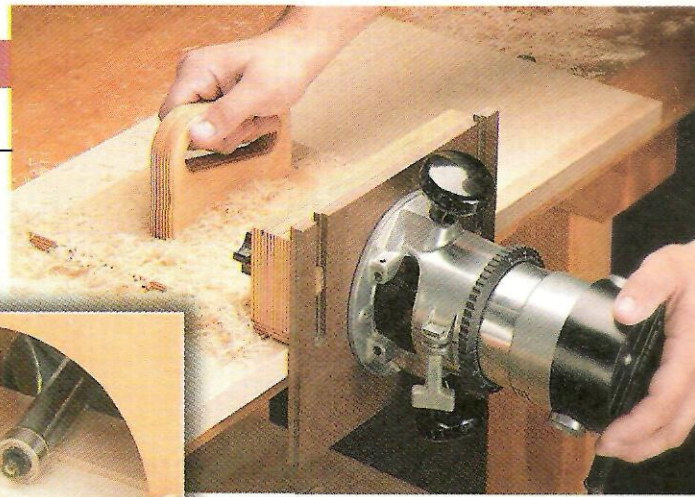

edges are rounded over with a router and a round-over bit. Then the handle is glued and screwed to the base of the jig.

There's just one last thing to take care of before using the jig. As you can see in Figure 1a, a clearance rabbet needs to be cut in the base of the jig to allow it to travel over the untrimmed edging. This rabbet can be cut on a table saw.

To use this jig, start by installing a flush trim bit in your router, see inset photo above. Then attach the jig to the baseplate using the toilet bolts, washers, and threaded knobs. You'll need to adjust the fence until the cutting edge of the bit is just flush with the base of the jig.

1 OVERVIEW

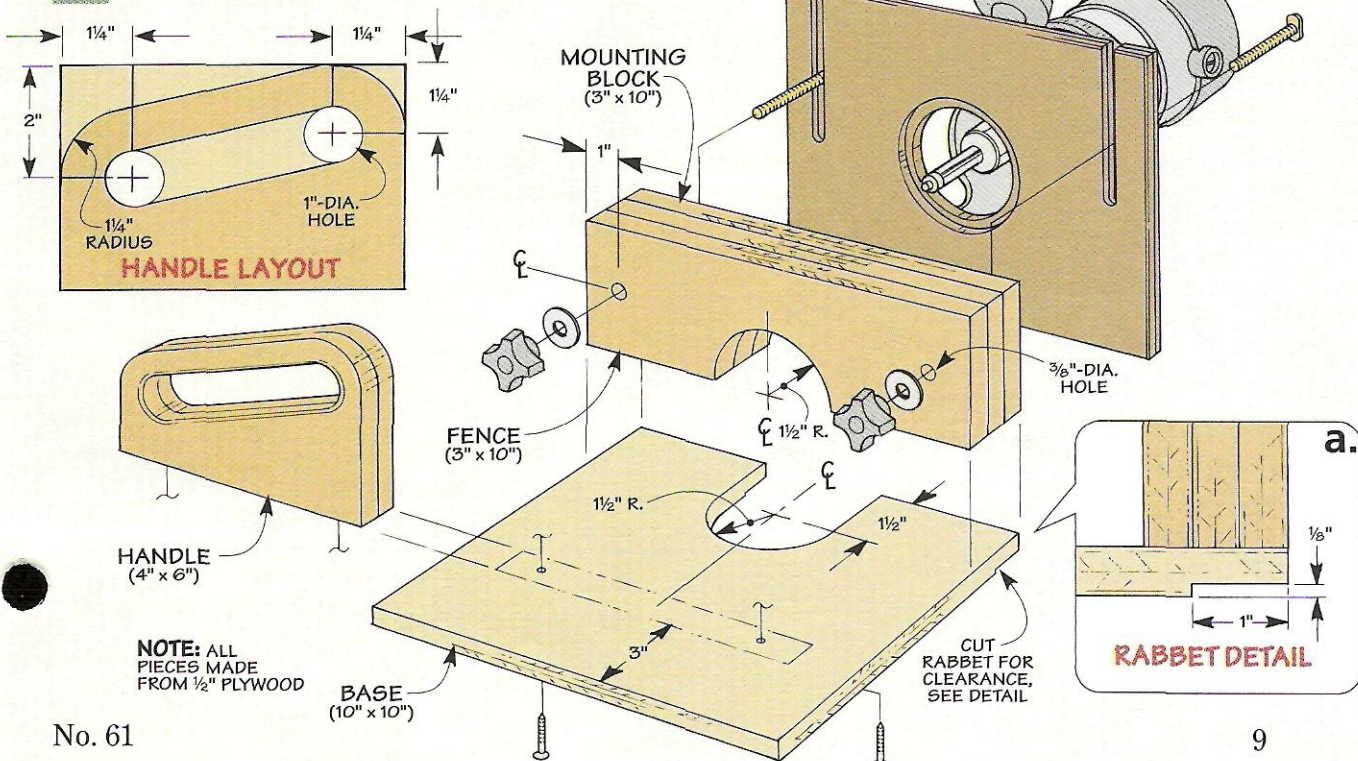

Edge Guide

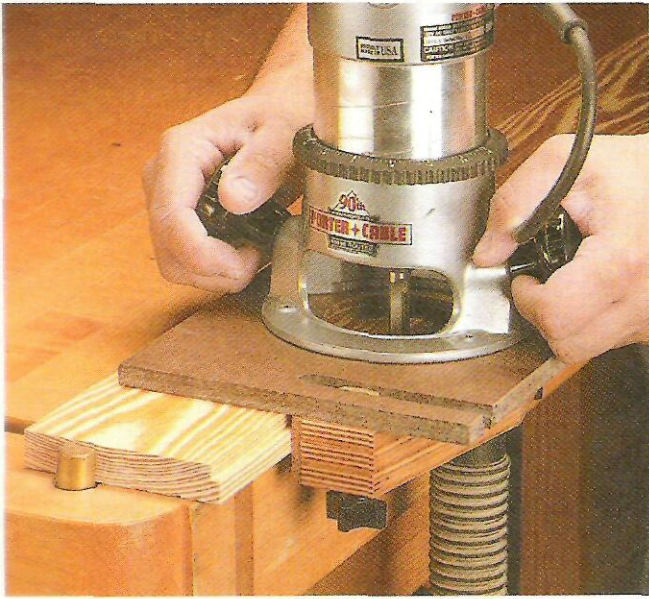

1 OVERVIEW

NOTE: FENCE IS 1/2" PLYWOOD; OPTIONAL FACE IS 1/4" HARDBOARD

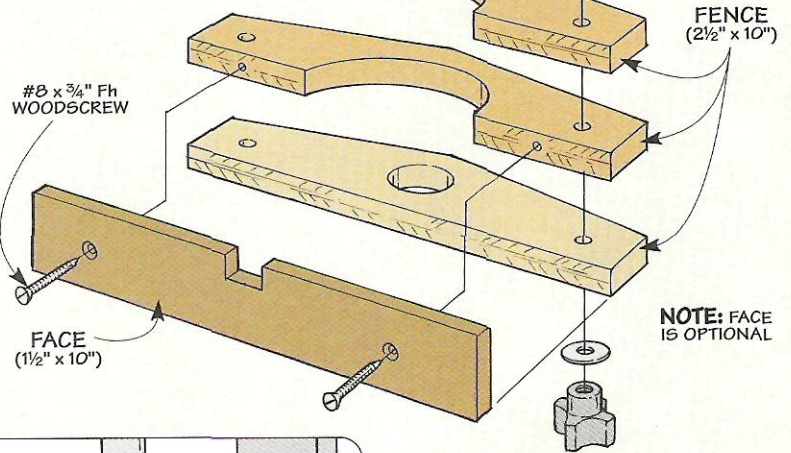

An edge guide for a router can come in handy any time you need to create a rabbet or rout a groove. But this edge guide has more to offer than most. It's designed so it can be hooked up to the hose of a shop vacuum, eliminating most of the dust and chips. (You'll need an adapter for the end of your shop vacuum hose.)

Of all the jigs in this system, the edge guide is probably the most basic. It's just a fence made up of three layers of plywood, see Figure 1. To build it, start by cutting three identical pieces of 1/2" plywood. Two of these are glued together to form the top section of the jig. The third piece can be set aside for now.

Once the two layers are glued up, lay out a semi-circle on one edge, centered between the ends of the

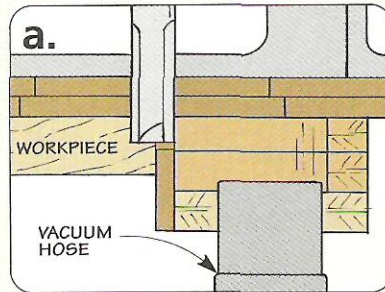

After this is done, a couple of tapers are cut along the back edge of the jig simply to help reduce the weight. These tapers can be cut with a band saw or jig saw and then sanded smooth with a belt sander.

The last step to complete the jig is to drill a hole in the bottom for the nozzle of your shop vacuum. The trick here is to size the hole so you get a nice friction fit when you insert the nozzle of the hose. (I made mine 1 3/8" in diameter.) If the opening ends up a little large, you can wrap a piece of duct tape around the nozzle of your hose to create a better fit.

To use the jig, simply attach it to the router base plate with the toilet bolts, washers, and knobs. Then adjust the jig in or out to position the groove or profile on your workpiece.

Optional Face – The opening in the fence is extra large to accommodate slot-cutting bits. But if you are using bits with a smaller profile, you may want to add a facing piece to reduce the size of this opening. This is just a piece of hardboard with a clearance notch for the router bit. The face is screwed to the fence so it can be removed.

2 OVERVIEW

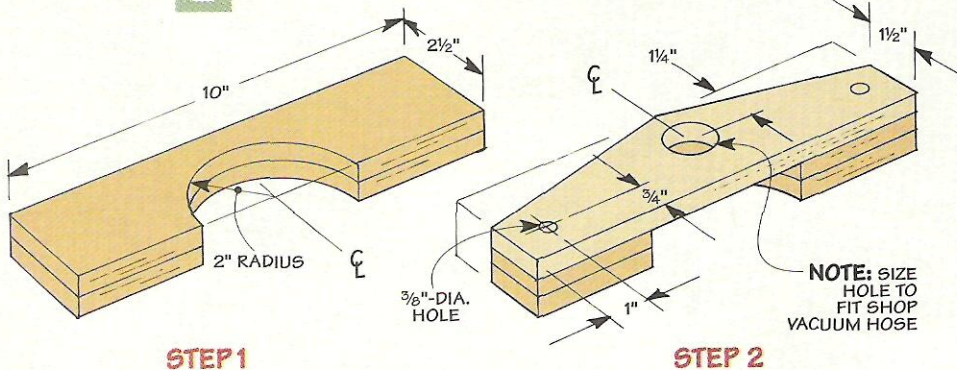

STEP 1

STEP 2

Circle Cutter

You can cut a circle out of wood using many different tools. But a router probably gives you the cleanest, most accurate results of any of them. The trick is to guide the router with a jig.

This circle cutter is nothing more than an adjustable auxiliary base that attaches to the base plate on the router. The jig slides in or out so you can cut circles varying from about 3" up to 18" in diameter. A pivot pin at one end of the jig fits into a small hole in the center of your workpiece, and the router then travels around this point, see photo at right.

The jig is made up of two layers — one of plywood and one of hardboard. This allows you to create a pair of T-slots for attaching the jig. And to make these slots, I used the same method as in making the T-slots in the base plate. A couple of 1/2"-wide slots are routed in the hardboard plate first. Then a pair of narrow (5/16") slots are routed in the plywood plate.

After these slots are routed, the two

layers can be glued together. It's a good idea to use the glue sparingly around the slots. This way you won't have to worry about coming back later to clean up glue squeezeout.

Once the glue is dry, you can lay out and cut the large opening in the center of the jig. Again, this can be done with a band saw or jig saw, and the opening can be sanded smooth with a drum sander.

Pivot Pin — A small nail serves as the pivot pin. A hole is drilled in the jig near one edge, and then the nail is epoxied in place.

Using the Jig — To cut a circle using the jig, start by laying out the circle and its centerpoint on your workpiece. Then drill a small hole in the workpiece for the pivot pin.

Next, a larger hole is drilled at the edge of the circle. This hole will be used as a "starter" hole for your router bit, so it should be at least as large as the diameter of your router bit. If you're going to be making a hole in a workpiece, drill the starter hole *inside* the circle you've laid out. If you are



making a disk or wheel, drill the hole *outside* of the layout line, as shown in Figure 2 below.

To rout the circle, carpet tape the workpiece to a backer board that is clamped to your workbench. (The carpet tape is important — it will hold the circle in place once it is cut free from the workpiece).

Set the router and jig on the workpiece so the pivot pin is in the small hole in the center of the circle and the router bit is in the starter hole. Now rout out the circle in multiple passes, lowering the bit about 1/4" between each pass.

1 OVERVIEW

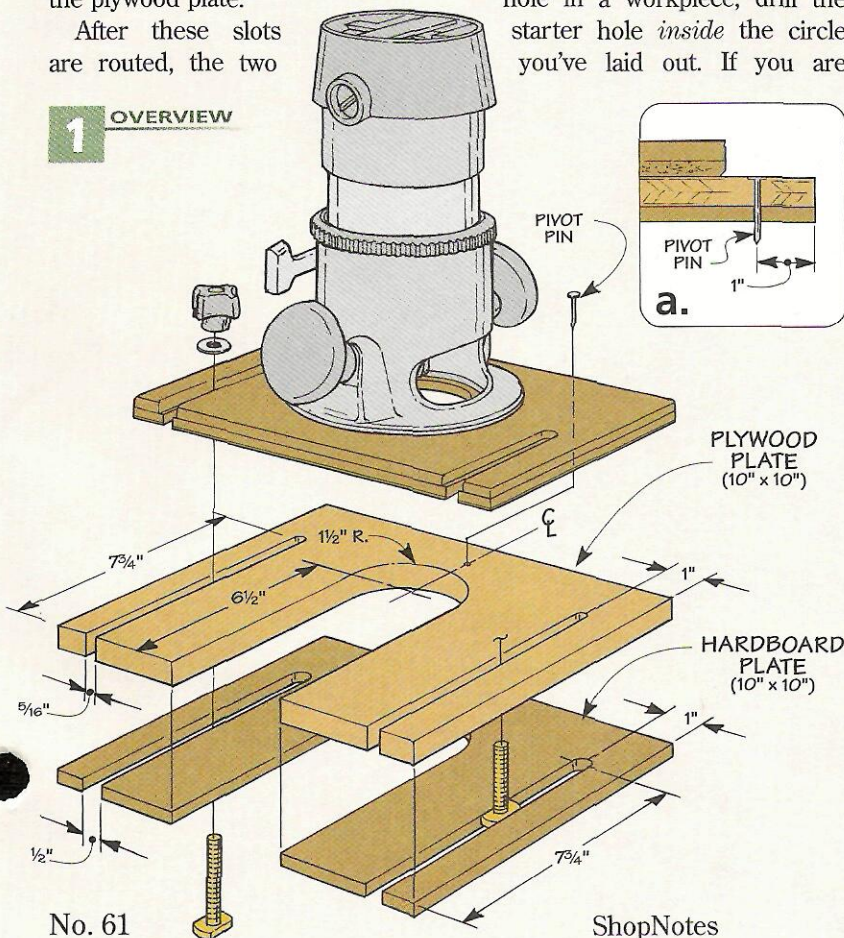

2 FIGURE

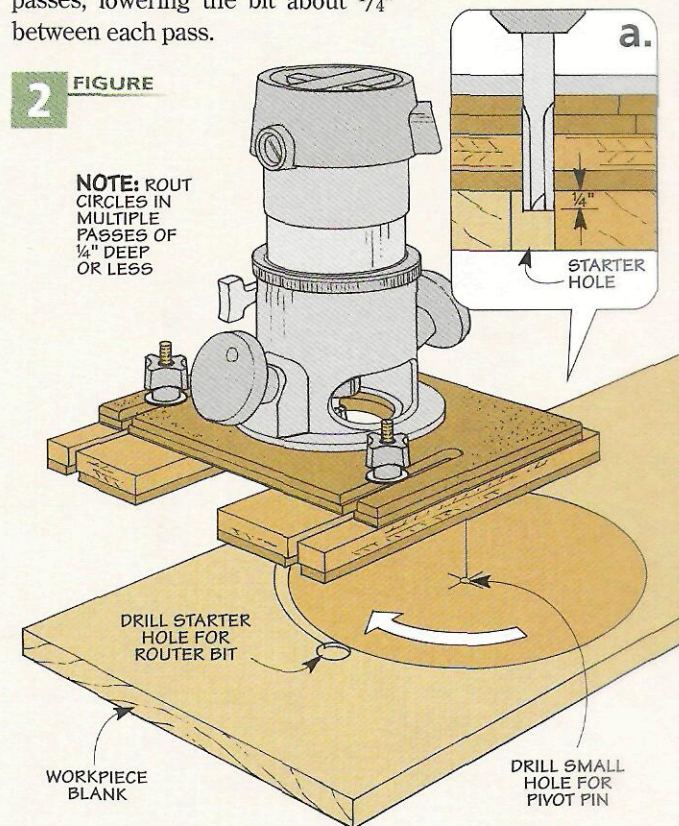

Table & Fence

Compared to the other accessories, it's a little hard to think of this router table and fence as a "jig." But it uses the same base plate that all the other jigs do. The router (with the base plate) just drops into the table, and the fence bolts to the T-tracks.

And although the table may look a little small, the fence features a support wing on each end that allows you to handle longer pieces, see photo. And the whole thing can be clamped down right on top of your workbench when you want to use it. Then stored underneath the bench or on a shelf when you're done.

Table – The table is really just an open box that supports the router and base plate. The base plate fits into a shallow recess on the top of the box, and the router is suspended beneath it.

To make the table, I started by cutting out a *bottom* and two *sides*

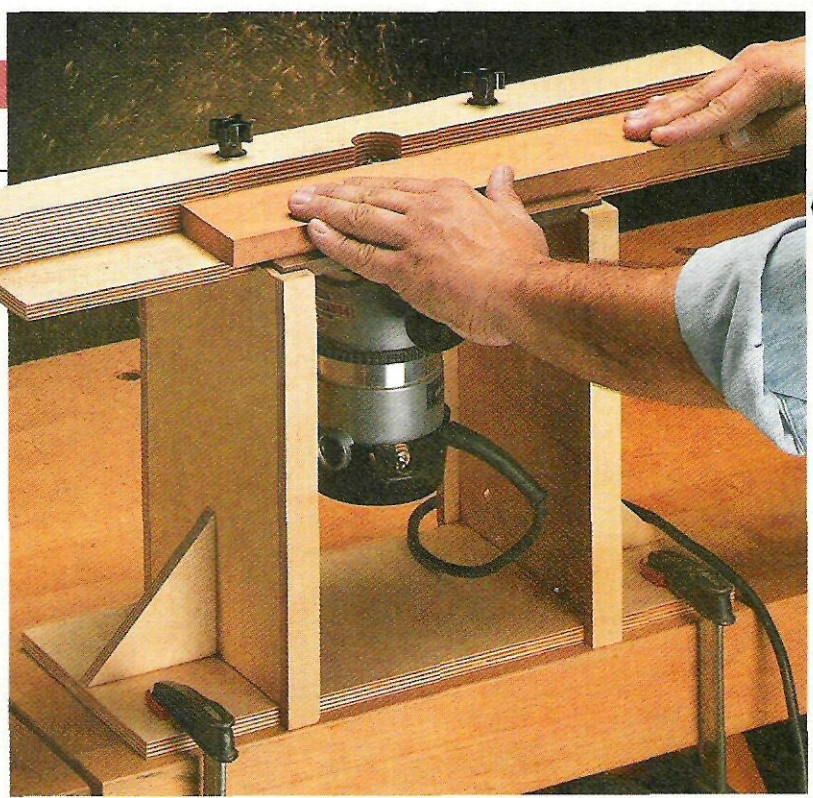

from 1/2" plywood. A couple of dadoes are cut in the bottom to hold the sides, as you can see in Figures 1 and 1b. I cut these on the table saw.

A rabbet is cut on the end of each side piece to support the base plate

and router. To ensure a snug fit between the router base plate and the sides of the table, it's important to size these rabbets carefully. If you take a look at Figure 1a, you'll notice that the base plate actually sits proud of the sides of the router table by 1/4". (I ended up making my rabbets 1/4" x 1/4".)

Before gluing the sides into the dadoes in the base, I cut a couple of triangular-shaped *braces* to help stiffen the sides of the router table. After you've cut these out, you can glue everything together.

In addition to the braces, some *facing strips* also help to stiffen up the router table. These plywood strips are glued to the edges of the sides and extend down over the edge of the base. At the top of the router table they create a lip, locking the base plate in place.

The last piece to add is a *cross support*. This is simply glued between the two sides at the back of the router table, flush with the bottom of the rabbets. It helps to keep the sides from buckling in.

Fence – With the table complete, you can start making the fence. The fence is just three layers of plywood that are glued together. It is secured to the base plate with toilet bolts, washers, and threaded knobs. A

1 OVERVIEW

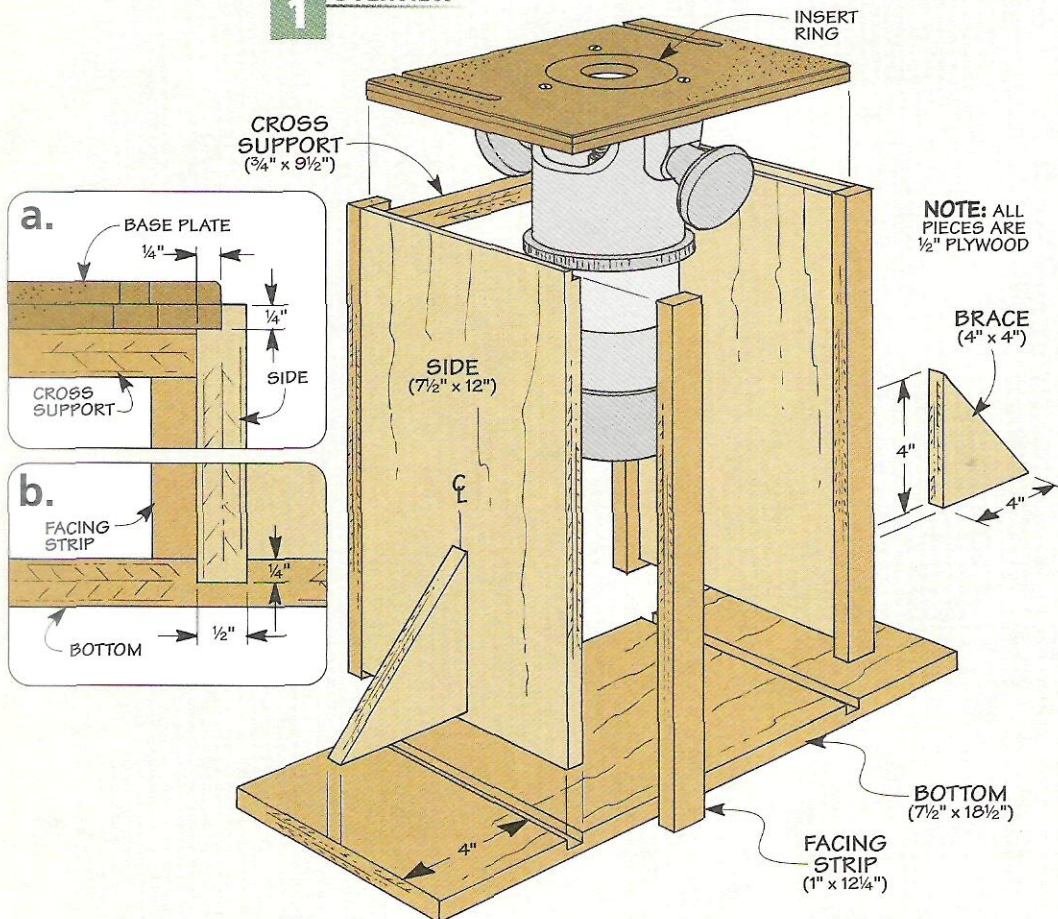

wing is attached to each end of the fence to serve as outfeed support.

As you can see in Figure 2, the main section of the fence is made by gluing up two long pieces of plywood. The third layer is actually made up of two shorter pieces that are glued to the bottom of the longer pieces. These are glued flush with the ends of the fence, leaving a gap in between for router bit clearance.

Once all the layers are glued up, you can drill a couple of holes in the fence for the toilet bolts that are used to attach it to the base plate. Then a small, semi-circular opening for router bits is centered on the front edge of the fence (Figure 2a). This opening can be cut out with a jig saw or band saw.

Finally, the *support wings* are added to each end of the fence. These are simply cut to size and glued in place. They not only support long workpieces, they also help to guide the fence so it travels smoothly as you slide it back and forth over the top of the table.

Insert Ring – The large opening in the router base is convenient when you're using the router in a hand-held position. It allows you to see what you're doing a little better. But when you're using the router in the router table, it's safer to have a

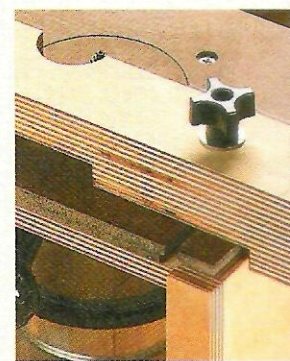
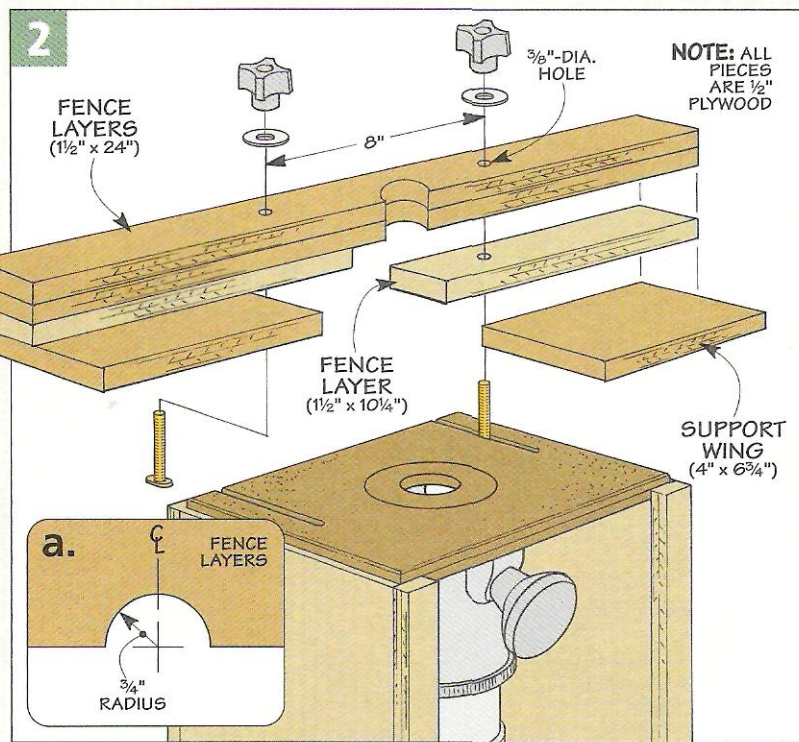

▲ Fence. This adjustable fence slides in the T-slots on the router base plate.

smaller opening around the router bit. So I made an insert ring that fits into the opening in the base plate, just like you see in Figure 3.

The insert ring is just a piece of 1/4" hardboard. It's cut out on the drill press, using a wing cutter. Start by carpet taping a hardboard blank down to a backer board that is clamped to your drill press, as shown in Figure 4. Now adjust the wing cutter to cut a disk that will fit in

the opening in your router base plate. The key is to size the disk so it fits in the opening snug but not too tight. (I had to make a couple of disks before I got the wing cutter adjusted just right.)

To create the opening in the insert ring, the wing cutter is re-adjusted to cut a smaller (1 1/2"-dia.) hole (Figure 5). Of course, you can make up several insert rings with openings of various diameters. 🛠️

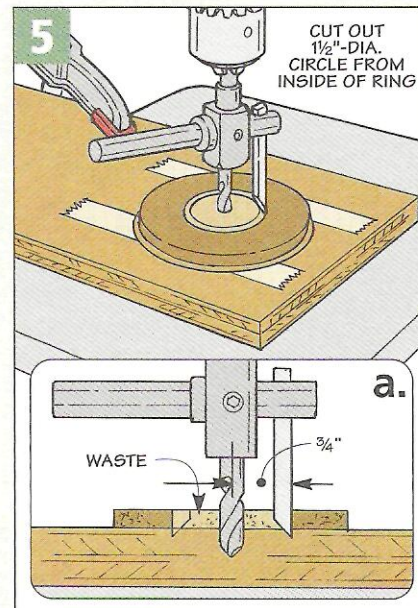
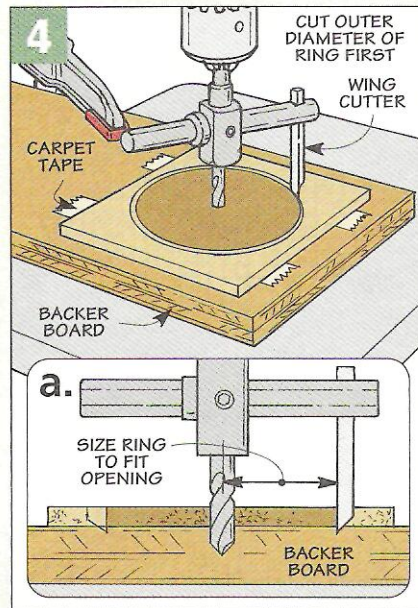
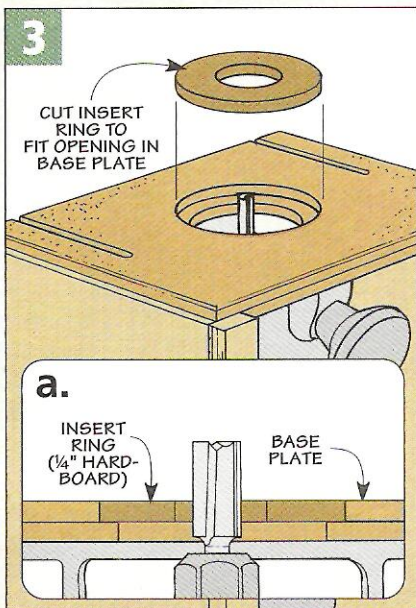

Brad Nailers

Luxury or necessity? You'll be convinced a brad nailer is both once you add one to your workshop.

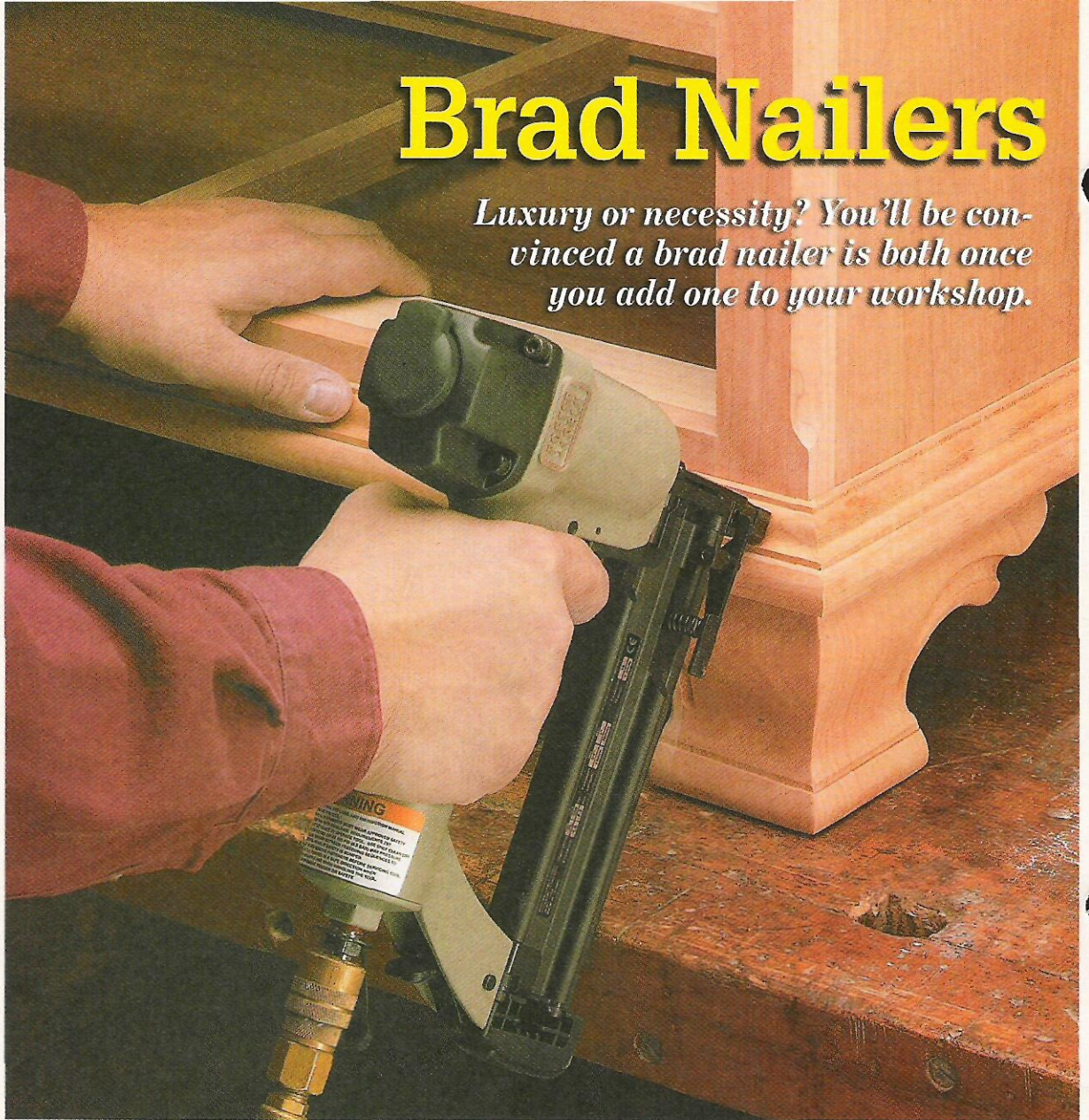

Most woodworkers probably wouldn't consider the brad nailer shown in the photo above a necessity. It's something that's more often associated with production cabinet shops or trim carpenters. And that's too bad really. Having a brad nailer in your shop can make your woodworking easier, faster, and more accurate.

How often have you had to hammer in a few brads to hold a piece of trim or to hold the back of a cabinet in place while the glue dried? With a brad nailer it only takes a few seconds. And you have one hand free to hold the workpiece in perfect position as you work.

Need to get into a tight place (like the inside of a cabinet) that's all but impossible to do with a hammer? Grab a brad nailer, and it's a snap. Plus, you don't have to worry about an errant hammer blow damaging the workpiece.

One area I use my brad nailer quite a bit is when I need to build a jig or fixture. With a few well-placed brads, I have a jig or fixture that's ready to use — no need to wait for any glue to dry. And for shop cabinets and storage projects, brads eliminate the need for any

clamps. Just add glue and then nail in some brads to “clamp” everything together.

You'll even find a few uses outside the shop. Brad nailers are handy for light-duty carpentry work, like installing trim around the house.

Price & Availability – Okay. By now, you might be interested in finding out a little more about brad nailers. And one of the first things you might be asking is where can you get one and how much is it going to cost? These days, just about any home center or hardware store will have a half-dozen or more brands. And they're not that expensive. Depending on the features it has (more on this later), you can find brad nailers priced from \$70 to \$150.

Air Requirements – As you may have guessed, a brad nailer isn't the only thing you'll need. A compressor is required to provide the “power” to the brad nailer. But don't worry. Almost any compressor that can provide about 2 cubic feet of air per minute (CFM) at a pressure between 70 - 125 pounds per square inch (PSI) will work fine. And if you don't have a compressor, those same home

centers often have “kits” that include the compressor, brad nailer, and the accessories you need to get started.

Driving a Brad – Regardless of the brand, all brad nailers operate in basically the same way and use similar terminology. (See Brad Nailer Anatomy at right.)

Once you connect the hose from the air compressor to an *air fitting* at the back, *compressed air* fills the body of the nailer and the area above the *cylinder* inside the head.

As you squeeze the *trigger*, the compressed air is released through the *head valve*, driving the *piston* inside the cylinder downward with tremendous force. Attached to the bottom of the piston is a *driver rod* that shears a single *brad* off a *clip* installed in a spring-loaded *magazine* along the bottom of the nailer, driving and countersinking the brad in the blink of an eye.

Once the piston reaches the end of its stroke, the pressurized air surrounds the lower part of the piston. This forces it back to the top of the cylinder as the air expels out of the *exhaust port*.

Brad Nails – This is an amazing process considering the wide range of brad lengths you can install in a nailer. Brad nails come in lengths as short as $\frac{3}{8}$ " to as long as $2\frac{1}{8}$ ".

But there aren't any brad nailers that can handle the entire range. In general, brad nailers fall into two distinct categories. The first drives

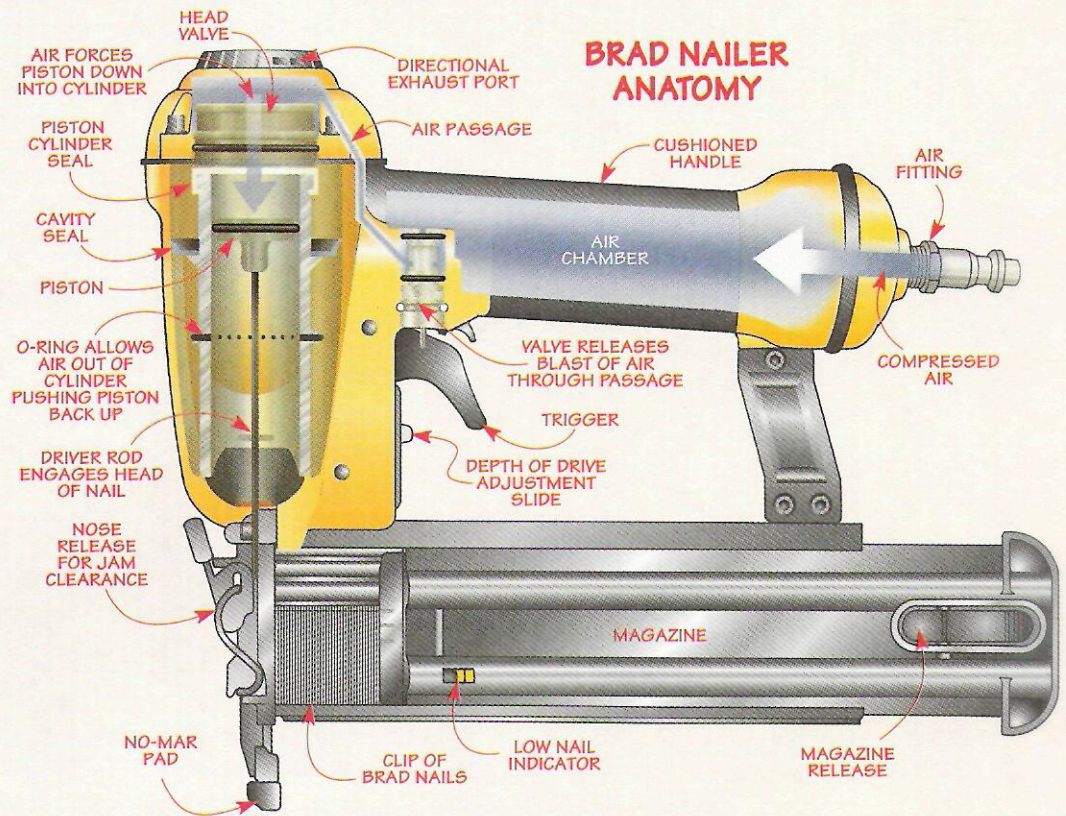

brads that range in length from $\frac{3}{8}$ " to a maximum of $1\frac{1}{4}$ " or $1\frac{1}{2}$ ".

But for the kind of work I do, I prefer the second category. These brad nailers will handle brads from $\frac{5}{8}$ " (or $\frac{3}{4}$ ") up to 2". The longer brad lengths allow me to perform a wider range of tasks, whether it's installing small trim around a project, securely fastening face frames to a cabinet, or installing some trim around the house.

Other than their lengths, all brad nails look pretty much the same. As I mentioned, they come in a clip which is a glued-up strip of nails, as shown in the margin.

This clip consists of around 100 brads that fit into the magazine (see photo at left).

Besides the fact that they come in a convenient package,

there are a number of other differences that make brad nails quite a bit different than a typical finish nail.

For starters, a brad nail is smaller in diameter (18 gauge). So it leaves a less noticeable hole in the workpiece that is much easier to fill.

And if you take a close look at the tip, you'll see that it's more blunt than a typical finish nail. This way, as it's driven in, it doesn't act like a miniature wedge and split small pieces of trim or molding.

Finally, the glue holding the brad nails together in the clip helps increase the gripping strength of the brads. As it's fired into the workpiece, the glue heats up and melts. As it dries, it helps "lock" everything together.

One last note on brad nails. Most manufacturers will tell you to use only their brand of fasteners. And I tend to stick with that.

But in a pinch I have used fasteners made by other manufacturers without any problems. Just be sure to test the fasteners in a couple of pieces of scrap before using them to assemble your project.

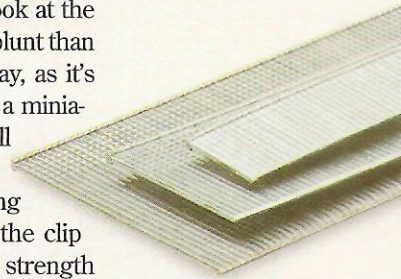

▲ **Nail Sizes.** Most brad nailers will handle a wide range of nail lengths, but often in two different ranges — $\frac{3}{8}$ " to $1\frac{1}{4}$ " or $\frac{5}{8}$ " to 2".

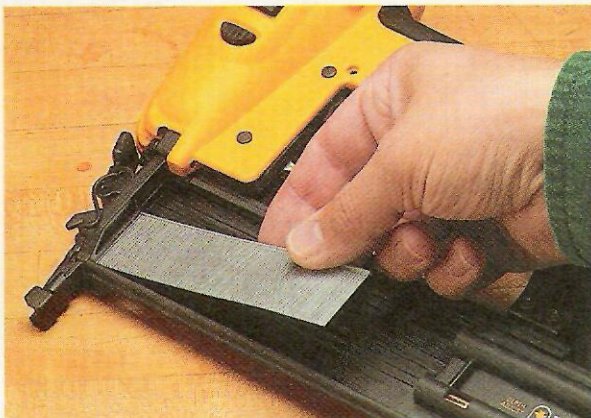

▲ **Loading.** Loading brad nails is easy and convenient. Just release the magazine, lay a clip inside (above), and then slide the magazine forward to lock it in place.

Features & Maintenance

Knowing that the basic operation of any brad nailer is identical, what's the best way to go about selecting one? As with many tools, it often comes down to a few select features. For brad nailers, there are a number that I've found to be pretty useful.

Safety – One of the first “features” I look for is a safety system. With compressed air driving a small nail, you certainly don't want to inadvertently fire the brad into a project or, more importantly, into yourself.

To avoid this, *all* brad nailers currently manufactured have one of two safety systems built-in — a dual trigger or a restrictive nose safety.

Dual Trigger – On a dual trigger system, squeezing the first trigger disengages the safety that prevents the brad nailer from firing. This allows you to squeeze the second

trigger to fire the brad.

Although this type of system works fine, once the first trigger is depressed, you can fire brads at any time — whether the nose of the brad nailer is against a workpiece or not.

Nose Safety – A better choice is a restrictive nose safety, like the ones shown at right. This type of safety prevents you from firing a brad until the spring-loaded nose is depressed against the surface of a workpiece.

When you're ready to drive another brad, you'll need to lift the nose off the workpiece to “reset” the safety. Just keep in mind that there



▲ **Safety.** A nose-mounted safety prevents the nailer from firing inadvertently. And a pad (left) on some nailers prevents the nose from denting the workpiece as it recoils, unlike a standard nose (right).

are *two* types of nose safeties: contact firing and sequential firing.

Contact Fire – In a contact firing nailer, the safety and trigger can be activated in any order. So you can depress the tip and then pull the trigger. Or you can hold the trigger in and “bump” fire the tool by pressing the nose wherever you want to drive a nail.

This feature is fine if accuracy isn't critical. But as a woodworker, I'm more concerned about placing my brad right where I want it — not driving as many brads as possible in a short period of time.

Sequential Fire – That's why I prefer a sequential firing nailer. This is where the nailer will not fire until you press the nose against the workpiece first and then pull the trigger.

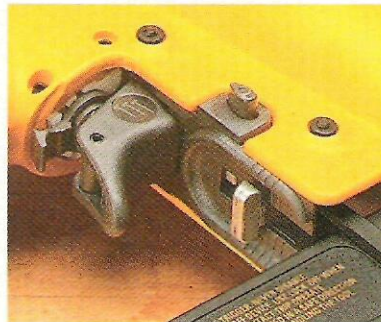
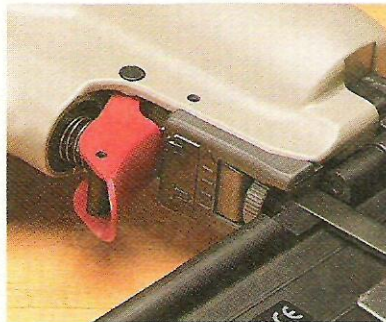

▲ **Depth Adjustment.** A mechanical depth adjustment like a thumb screw (left) or sliding tab (right) makes fine tuning how deep the nail is set easier than having to modulate the amount of air coming from the compressor.

Nailer & Stapler Combination Tool

A number of manufacturers have designed tools that not only drive brad nails but also crown staples in a variety of lengths (1/2" to 1"). If you're not sure whether you're more likely to need a nailer or stapler or would like both capabilities in one tool, a combination tool might be just what you're looking for.

The nice thing about these tools is that there isn't anything to adjust on the tool when you need to change from nails to staples. Just swap the

fasteners and adjust the drive depth.

Price – Now you might think that you'll pay extra for this feature. But you can often pick one up for just about the same price as either of the individual tools — around \$125.

As you might guess, you don't get something for nothing. The downside to the dual capability is you'll have to settle for short to mid-length fasteners. And the driver rod often leaves a larger indentation in the workpiece when you're firing brads.



Once you lift the nose off the workpiece, you have to release the trigger and then press the nose back down again before the nailer will fire.

Depth of Drive – Driving the brad just below the surface of a workpiece is critical. To do this accurately on many brad nailers, you have to spend time adjusting the air pressure at the compressor.

But I consider a depth of drive adjustment on the tool a “must-have.” As you can see in the photos on the opposite page, a depth of drive adjustment allows you to change how far the brad is driven into the workpiece — *without* having to walk back and forth to the compressor.

Note: Some minor adjustments may need to be made at the compressor when you change to a different *length* brad.

Clearing a Jam – If you plan to use a brad nailer day in and day out, it’s worth giving some consideration to how easy it is to clear a jam. Just like it sounds, this is when a brad gets stuck in the nose of the nailer instead of firing into the workpiece.

As you can see in the photos above, there are basically two “systems” for clearing a jam. One requires an Allen wrench to disassemble the nose. So even if it only jams once, this can be a real hassle.

I prefer a system that offers a hinged or spring-loaded quick



▲ **Jam Clearing.** Brad nailers that require you to disassemble the nose with an Allen wrench (left) can be a big hassle when you need to clear a jam. But clearing a jam is an easy task on a brad nailer with a quick-release latch (right).

release latch that operates from the side or front of the nose. It’s the fastest and most convenient way to clear a jam from the nailer.

Before clearing a jam with either system, it’s important to always remove any remaining brads from the magazine (and disconnect the gun from the air hose). Since the magazine is spring-loaded, it can eject a clip across the room (or into your face) once you release the nose.

Combination Tool – One last “feature” to note is that some brad nailers will perform double-duty. These combination tools are designed to drive brads *and* crown staples. For a little more information on these tools, refer to the box at the bottom of page 16.

Care & Maintenance – With few moving parts and no motor, it would be easy to assume that a brad nailer is maintenance-free — and for the most part it is. But like most tools, there are couple things you can do to keep a brad nailer working like new.

As with any air-powered tool, it’s a good idea to keep excess moisture from getting inside. Now, you could use an in-line filter. But I’ve found that simply draining the tank on my compressor on a daily basis works just as well. (And I have to do it to maintain the compressor anyway.)

But the most important thing is to add a couple drops of oil every day (or at least each time you use it), as shown in the photo at left. This keeps all the parts moving freely and

prevents the seals from drying out and deteriorating.

The problem is the oil mixes with the compressed air that exhausts out the nailer. This can contaminate the workpiece and cause problems later when you apply a finish.

One option is to select an oil-less nailer. But there aren’t many available, and they’re usually more expensive.

Instead some manufacturers exhaust the air out the back or make the exhaust ports adjustable (photo below). This way, you can direct the air away from the workpiece.

Conclusion – All in all, it’s hard to think of a reason not to buy a brad nailer. They’re a safe, maintenance-free tool. They make the task of driving a brad nail easier, faster and more accurate — whether it’s in the shop or around the house.

So the next time you’re at the home center, stop and check out the latest brad nailers. You just might decide it’s time to add one to your shop. 🛠️

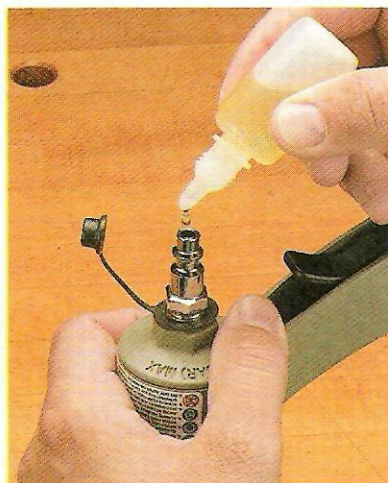

▲ A few drops of oil in the fitting prior to each use will keep your brad nailer firing smoothly each time you use it.

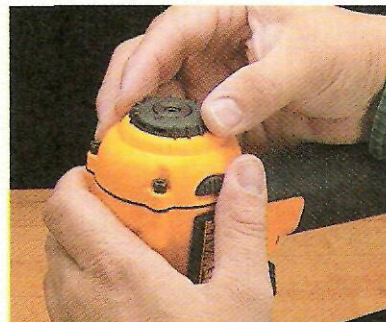

▲ **Exhaust.** Redirecting the air (and oil) from you and your workpiece is easy with an adjustable exhaust port.

Drill Press Sharpening Wheel



Get razor sharp hollow-ground chisels and plane irons with your drill press.

Have you ever tried to sharpen a chisel on a grinder and watched as the blade flashed from silver to yellow to blue in just seconds? That happens because the friction from the fast-spinning grinding wheel causes the blade to heat up and lose its temper. And once it does, the tool loses its ability to hold an edge and is ruined.

So what's the solution? A slow-speed grinder is one answer. Because the grinding wheel spins slower, there's less chance of ruining a tool by overheating it. But slow-speed grinders aren't cheap. So we decided to come up with our own version. Instead of a slow-speed motor, however, the sharpening jig shown here uses a tool you probably already have in your shop — a drill press.

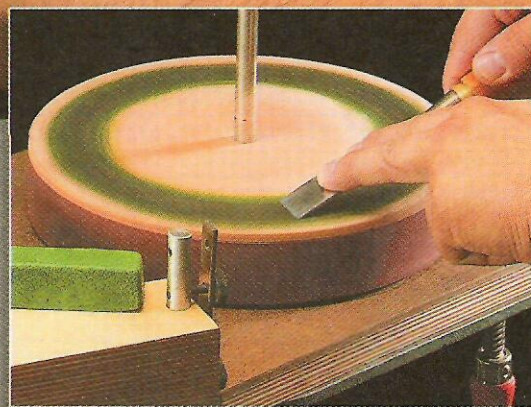

The grinding “wheel” on this jig is really a large disk made out of two layers of MDF (medium-density fiberboard). Cloth-backed sandpaper is glued to the rim and the wheel is chucked up in the drill press. By setting the drill press to its lowest speed, you have a slow-speed grinder that sharpens your tools quickly with much less risk of burning them. And a pivoting arm holds both chisels and plane irons at the proper angle so you end up with a perfect, hollow-ground bevel, see photos at left.

This jig not only sharpens your tools, it also has a built-in honing feature, as shown in the inset photo above. A piece of leather is mounted to the top of the wheel and is charged with rouge or honing compound. The stropping action of the leather imparts a highly polished edge to the bevel of the tool.

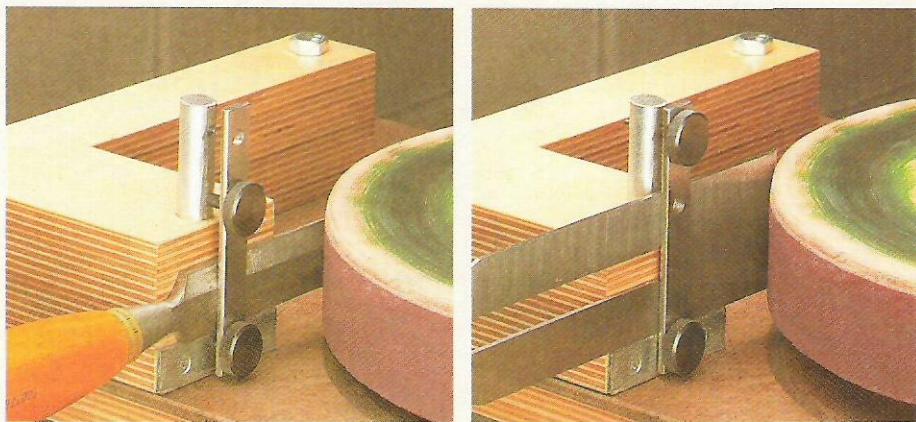

▲ *Versatile.* The sharpening jig features a tool holder that can accommodate chisels as well as plane irons. A couple of knobs and a steel clamping bar hold the tool firmly in place while it is being sharpened.

EXPLODED VIEW
OVERALL DIMENSIONS:
 17"W x 12"D x 12"H

NOTE: SET DRILL PRESS AT LOWEST SPEED

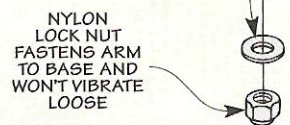
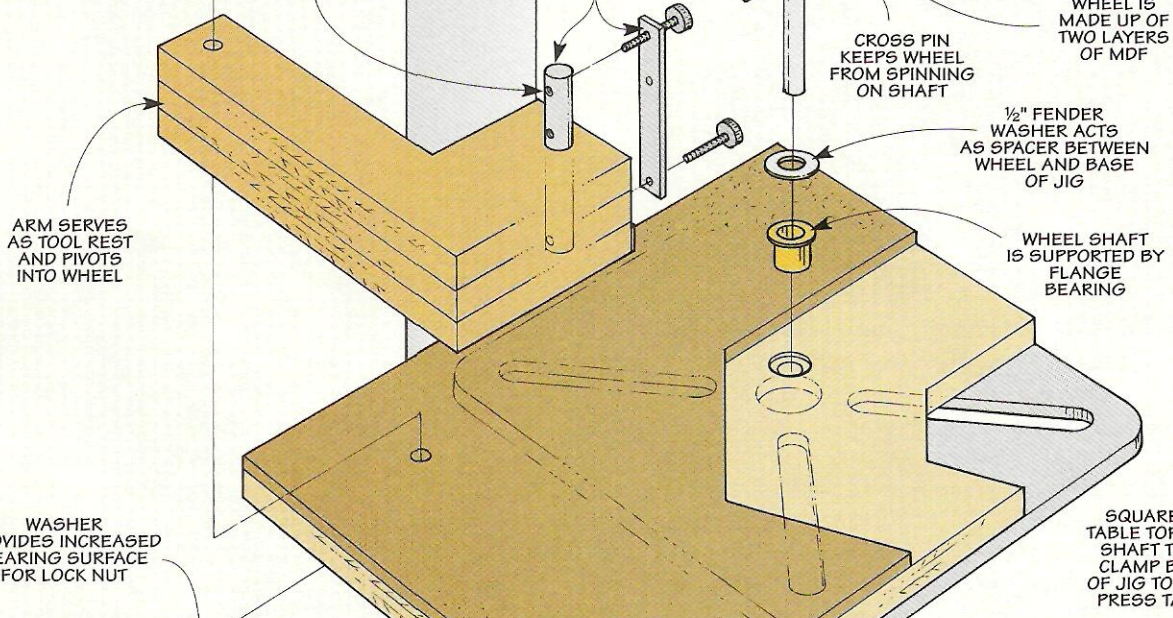
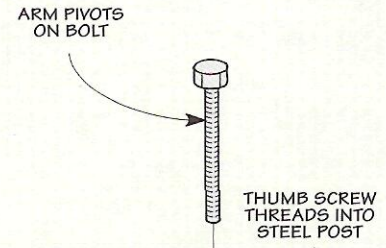
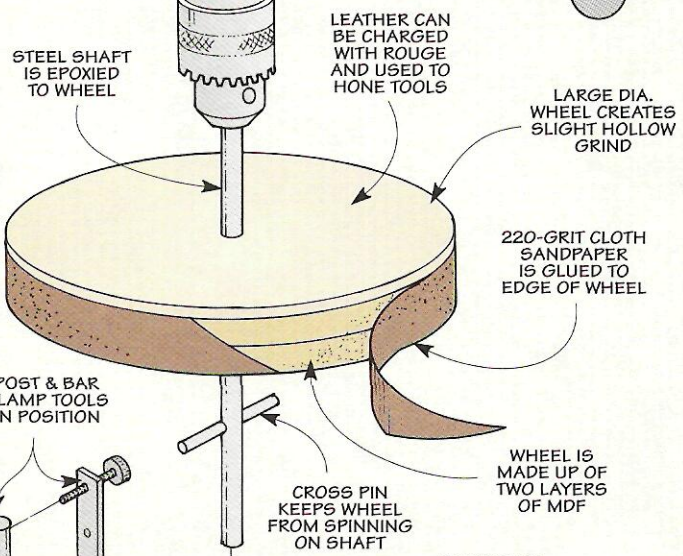

NOTE: CLAMPS NOT SHOWN FOR CLARITY

Hardware

- (1) 1/2" x 18" Steel Rod
- (1) 3/16" x 3" Steel Rod
- (1) 1/2" I.D. x 3/4" O.D. - 3/4" Flange Bearing
- (1) 1/2" Fender Washer
- (1) 5/16" x 3" L-Bracket (Mending Plate)
- (2) #6 x 1" Fh Woodscrews
- (4) #8 x 3/4" Fh Woodscrews
- (2) #10-32 x 1" Thumb Screws
- (1) 1/2" x 1/8" Steel Plate (3 3/4" long)
- (1) 3/8" x 3 1/2" Hex Bolt
- (1) 3/8" Nylon Lock Nut
- (1) 3/8" Flat Washer
- (1) Roll of 1/2"-Wide Sandpaper
- (1) Leather

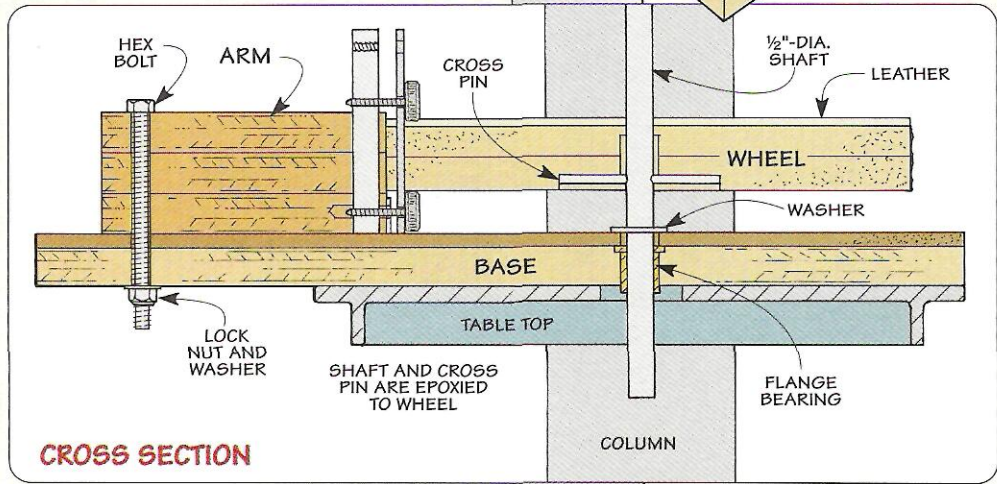

CROSS SECTION

Table & Arm

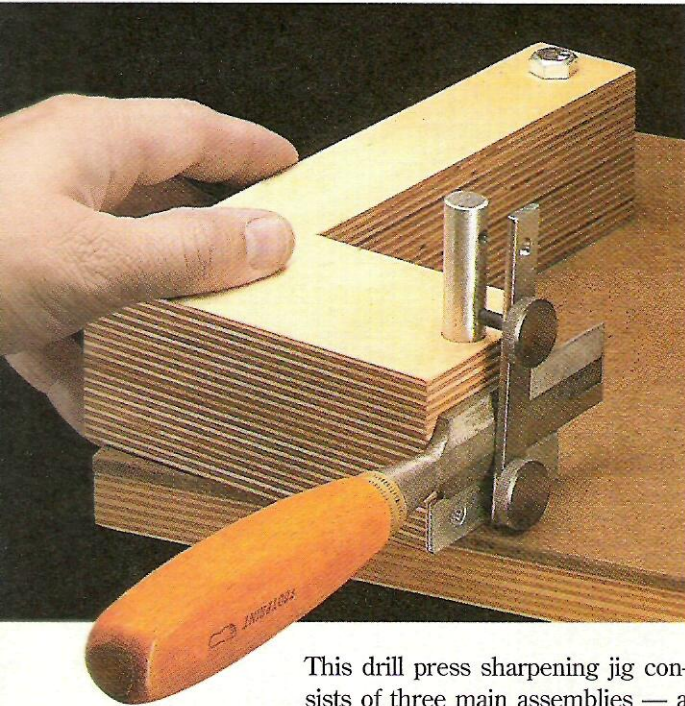

▲ **Pivoting Tool Rest.** The pivoting design of this tool rest allows you to swing out the arm to examine your progress while sharpening.

This drill press sharpening jig consists of three main assemblies — a sharpening wheel that is chucked up in the drill press, a pivoting arm that holds the tool to be sharpened, and a base that supports everything. Because the base will be used to assemble and true up the sharpening wheel, I made it first.

If you look at Figure 1 above, you can see that the base is nothing more than a piece of 3/4" plywood covered with a piece of 1/4" hardboard. Sandwiched in between these two pieces is a bronze flange bearing. The shaft of the sharpening wheel will ride in this bearing once the jig is complete. But I'm getting ahead of myself.

To make the base, start by cutting

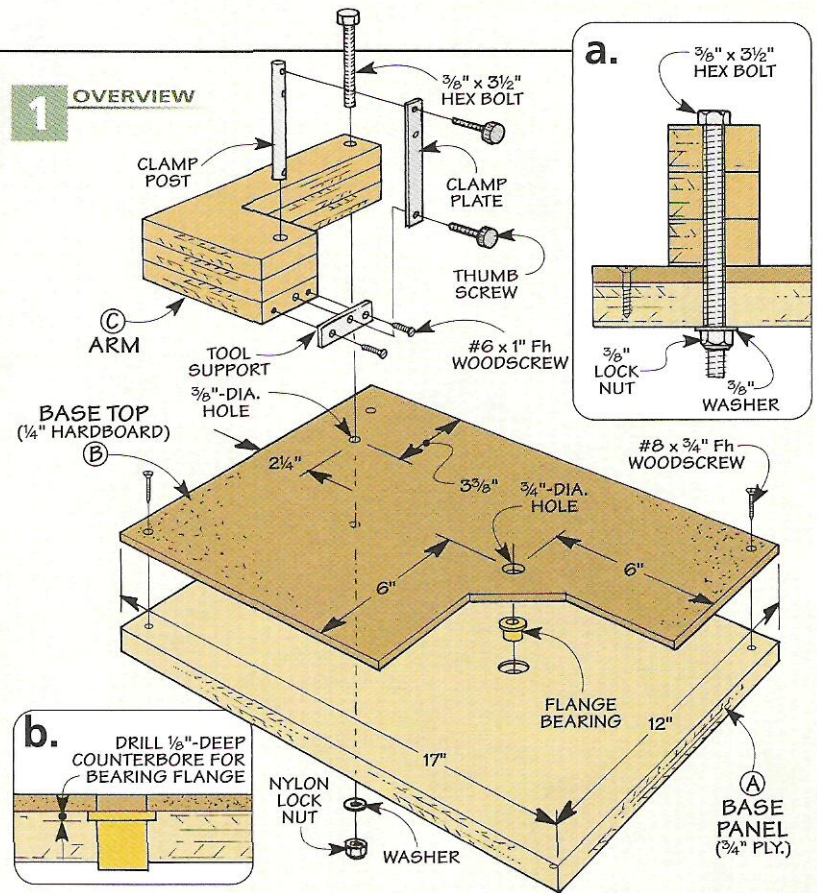

a plywood *base panel* (A) and a hardboard *base top* (B) to identical size. There are two holes in the base. One is for the flange bearing and the other is for a hex bolt that will serve as the pivot point for the arm of the jig. To make sure these holes line up perfectly, I taped the two layers of the base together on the edges before laying out and drilling the holes. (I just used a few strips of masking tape to hold the two panels together temporarily.)

Once the holes are drilled, a Forstner bit can be used to drill a shallow (1/8"-deep) counterbore in the top of the plywood panel (Figure 1b). This is for the flange of the wheel shaft bearing. Once this is done, the hardboard and plywood panels can be screwed together, with the bearing trapped in between them. But I didn't glue these two pieces together. This way you can get at the flange bearing in case you ever need to replace it.

Arm – With the base complete, you can begin making the arm of the jig. The main purpose of the arm is to serve as a tool rest. Chisels or plane irons can be clamped to the arm and then held against the rotating sharpening wheel.

The *arm* (C) is cut from a blank glued up out of three layers of plywood (Figure 2). It's cut to an L-shape with a band saw or a jig saw. Then a hole is drilled at each end. One of these holes is for the hex bolt that attaches the arm to the base. And the other is for a steel rod that

2 FIGURE

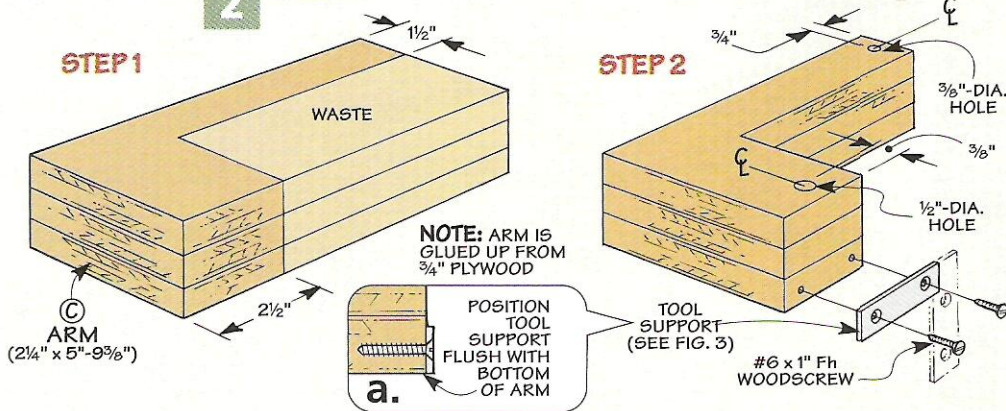

will be used to clamp the tool that is being sharpened in place.

To complete the arm, you'll need to do a little metalworking. But don't worry. There's nothing too involved here. Mostly just some sawing, drilling, and tapping (and there are even a few tips on tapping at the end of this article, see page 25).

There are three metal parts that you'll have to make for the arm. The first is a *tool support*. This is just a small, thin piece of steel that is screwed to the end of the arm. The edge of the chisel or plane iron you want to sharpen will rest on this support, like you see in the photo on the opposite page.

I made the tool support by cutting off one of the legs of an L-bracket (also known as a mending plate). You can find these at most hardware stores. The nice thing about using a mending plate for the tool support is that the mounting holes are already drilled. But you'll have to make two

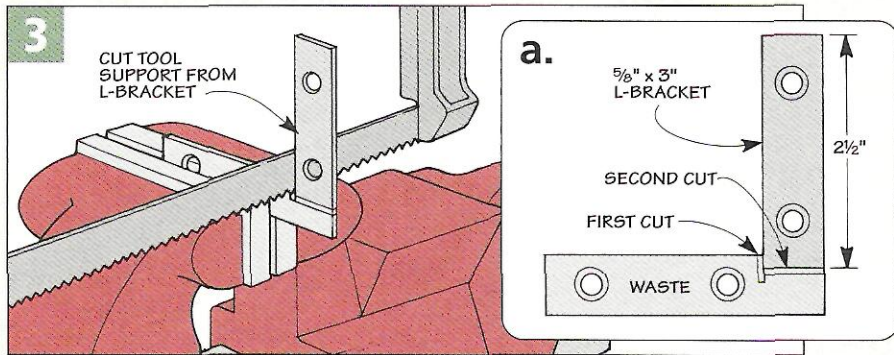

separate cuts with a hacksaw to cut this piece out of the L-bracket, as you can see in Figures 3 and 3a.

The tool support is screwed to the end of the arm, flush with the bottom. When it's in place, you can drill a hole through the support and into the arm as shown in Figure 4. Keep in mind that you'll need to make this hole deep enough to provide clearance for the thumb screw that is added later (Figure 4a).

The tool is held in place by a *clamp plate*. Turning a couple of

thumb screws tightens the clamp plate against the tool, holding it firmly in place. The thumb screws are threaded into a steel post that is mounted near the end of the arm. To accommodate different widths of tools, there are two positions for the top thumb screw.

You can cut the clamp plate from a piece of steel stock. (Steel stock can also be found at most hardware stores.) Then drill three oversize ($1/4$ "-dia.) holes for the thumb screws as shown in Figure 5a.

The *clamp post* is cut from a piece of steel rod. It also has three holes drilled in it, but these holes are smaller and are tapped to match the threads on the thumb screws. To help support the steel rod while drilling the holes, I used a V-block. (For more on drilling and tapping these holes, please turn to page 25.)

Assembly – Once you've finished work on all the metal parts, you're ready for some assembly. The arm is attached to the base with a hex bolt, washer, and a nylon lock nut (Figure 1a). Just make sure that you don't tighten the nut down all the way. The arm should pivot freely, but shouldn't have any up and down play.

To add the tool clamp, first push the rod into the hole in the arm so the tapped holes face forward (Figure 5). (Note that the post doesn't bottom out in the arm.) You'll have to check and make sure that the bottom hole on the post lines up with the hole you drilled earlier in the tool support, as shown in Figure 5a. Then simply add the clamp plate and thumb screws.

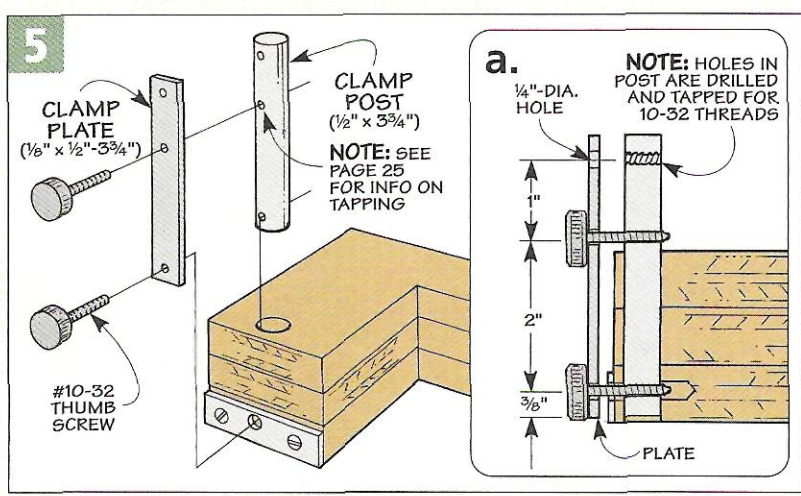
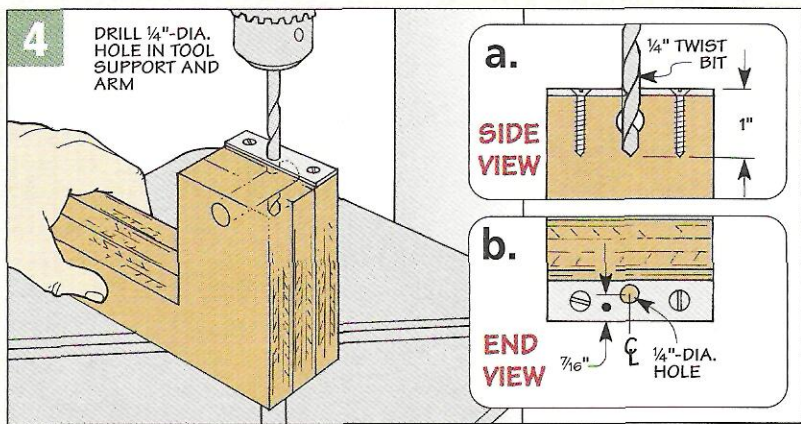

Wheel

With the base and arm complete, you can concentrate on making the wheel. There's nothing complicated about the wheel — it's simply two layers of MDF that are glued together and then epoxied to a steel rod that serves as the shaft.

The important thing is that the wheel runs true. Later, I'll share some tips on how to go about this. But for right now, start by cutting a couple of oversized pieces of MDF for the wheel. These can be glued up into a square blank (Figure 8).

Leather — The top of the wheel is covered with leather to allow you to hone your tools after you've sharpened them. I used a small piece of vegetable-tanned tooling leather (see page 35 for sources). The leather can be cut with a utility knife and glued to the blank with contact adhesive. Don't worry about cutting the leather to fit the blank exactly — you'll be trimming off the excess when you cut the wheel.

Layout — After you've glued the leather down, turn the blank over and mark the center. Using a compass, lay out a 10"-dia. circle around the centerpoint.

Before cutting out the wheel, the hole for the steel rod is drilled in the blank. This is a two-step procedure. First, a deep, 3/4"-dia. counterbore is

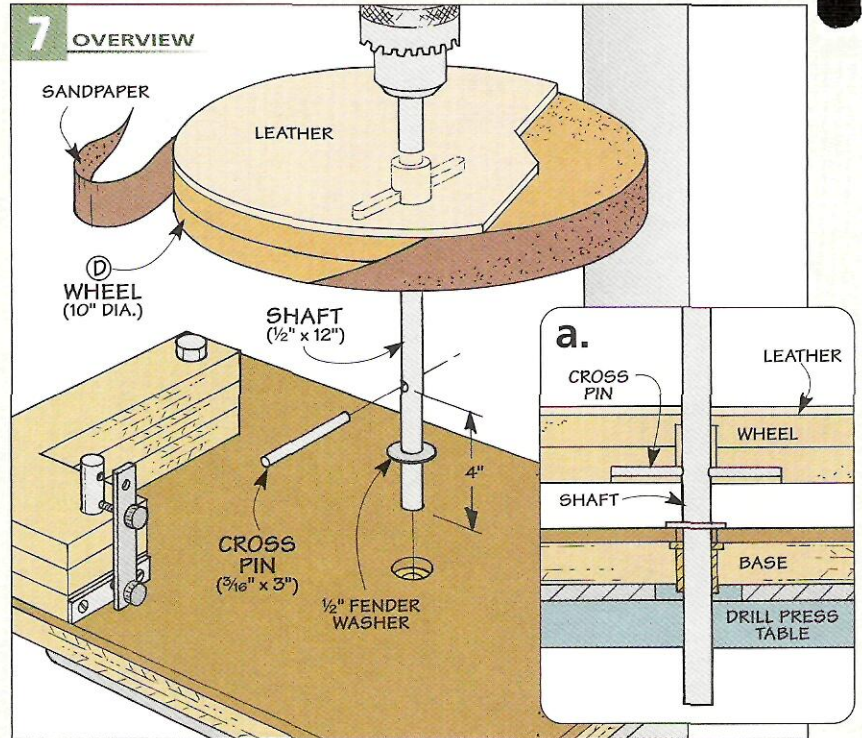

drilled in the blank (Figure 8a). Then a 1/2"-dia. hole is drilled the rest of the way through the blank and the leather. The oversized counterbore creates a "well" that will hold the epoxy around the 1/2"-dia. rod.

I didn't want to rely on epoxy alone to hold the wheel to the rod. So I decided to use a cross pin through the rod, as you can see in Figure 7 above. In order to hold the cross pin,

a shallow groove is routed in the bottom of the wheel blank (Figure 9a). I made this groove with a handheld router and a simple fence, like you see in Figure 9 below.

Cut Out Wheel — When you've finished making the hole and slot for the rod and cross pin, you can cut the wheel out of the blank on a band saw (Figure 10). Try to cut as close to your layout line as pos-

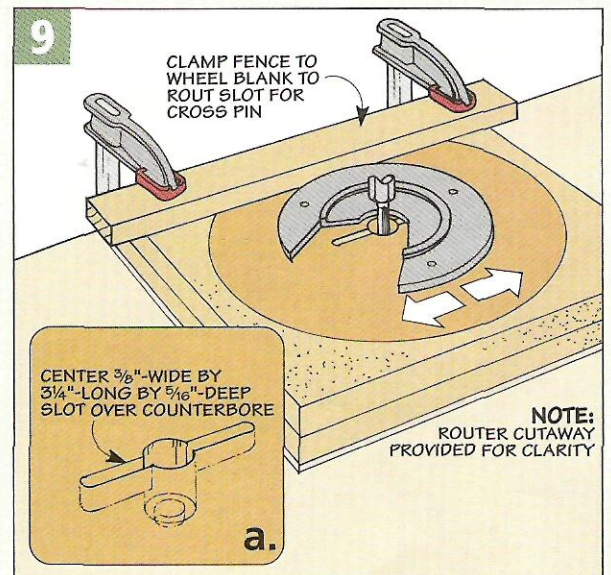
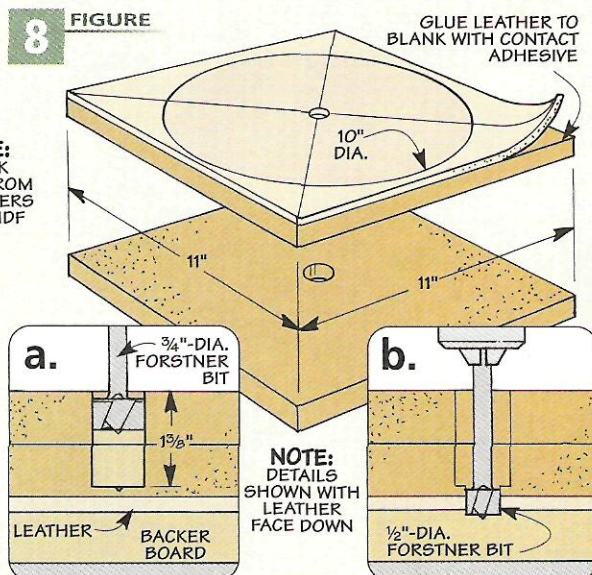

▲ **Scarf Joint.** Use a utility knife to cut a scarf joint in the sandpaper. Then glue the sandpaper to the wheel with contact adhesive. (See page 35 for sandpaper sources.)

sible, but make sure to stay on the waste side of the line.

Wheel Shaft – The shaft that passes through the wheel is a piece of 1/2"-dia. steel rod (also available at hardware stores). After cutting it to length, you'll need to drill a cross hole for the pin. To help hold the rod while drilling it, I made a simple V-block for my drill press. Then I clamped the rod and block down to my drill press while drilling the hole.

The cross pin is cut from a piece of 3/16"-dia. steel rod. After slipping the pin into the cross hole in the shaft, test the fit of the shaft and cross pin in the wheel. When everything fits, you're ready to epoxy the shaft into the wheel.

Epoxy – There are a few things to point out here. First, to get the wheel as square to the shaft as possible, I

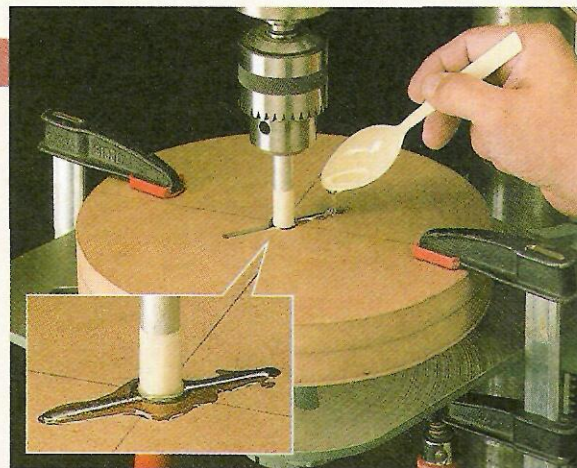
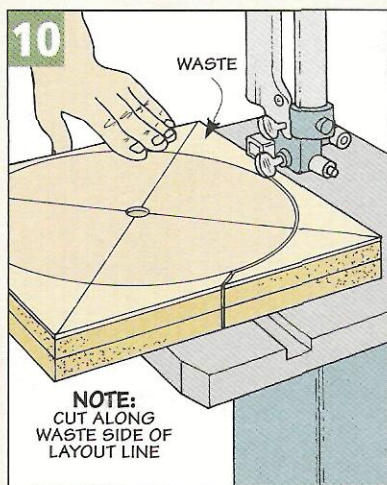

▲ Adding the Epoxy. Carefully spoon the epoxy all around the shaft and cross pin, letting it ooze into the "well" created by the counterbore. You can temporarily mask off the shaft with a piece of tape.

clamped it to the drill press table and chucked up the shaft while gluing it in place, see photo above. And to ensure a good hold, I used a slow-setting, high-strength epoxy.

Once the epoxy is dry and

scraped flush, the wheel needs to be trued up. To see how I did this, take a look at the box below. The last step is to glue a strip of sandpaper around the edge of the wheel, see photo in margin on opposite page.

Truing the Wheel

In order for the wheel to run as smoothly as possible, I decided to true it up on the drill press after it was epoxied to the shaft. To do this, I used a router and a simple jig.

The wheel-truing jig is just a three-sided plywood box that supports the router, see drawing at lower right. The router is mounted to the front of the jig and then the whole thing is clamped

down to the base of the sharpening jig and the drill press table.

The wheel is trued by raising it up and down as it spins past the rotating router bit. At first, this may seem a little unusual (and perhaps a little intimidating). But it works quite well. However, there are some important safety points to keep in mind.

First and foremost, you need to take

several *light* passes (no more than 1/64" deep), lowering the bit after each pass. You're really just shaving off material from the high spots of the wheel.

The second thing to remember is to go slowly. The drill press should be running at its *slowest speed*. And you should also lower the wheel down onto the router bit *very slowly*. If the router bit starts to grab or the wheel starts to chatter, slow down on the feed rate or take a lighter pass.

After several passes, you'll wind up with a smooth, trued-up wheel. Now you're ready to glue on the sandpaper.

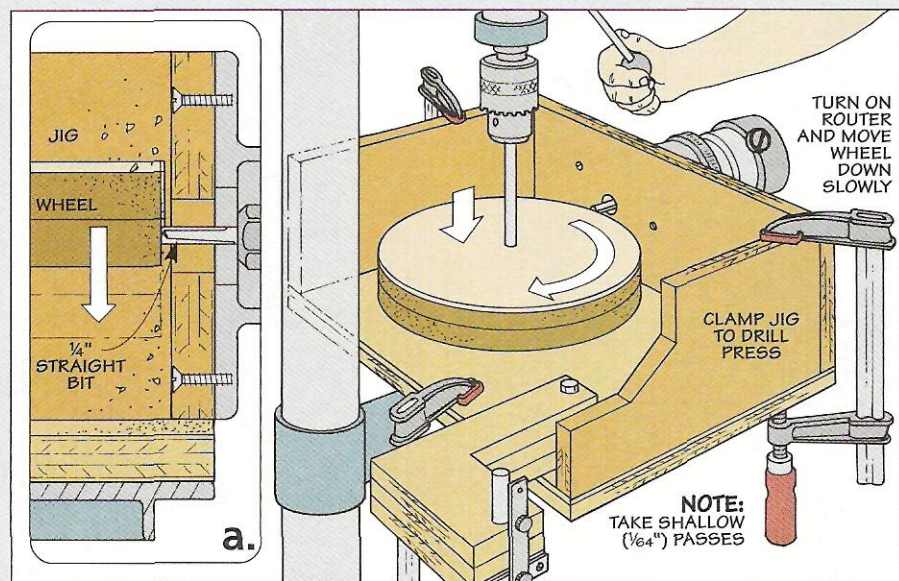

WHEEL-TRUING JIG

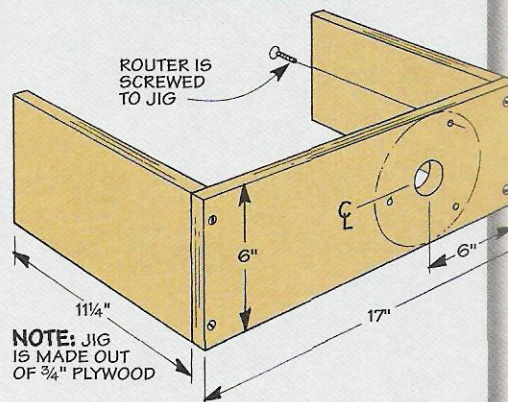

Set-Up

Setting up the jig on your drill press is pretty straightforward. Start by placing the shaft in the bearing of the jig and then setting the jig on the table of your drill press. Now raise the drill press table up so that you can tighten the drill press chuck around the shaft of the wheel.

After you've tightened the drill chuck, you can clamp the jig down to the drill press table. Then you'll need to lower the drill press table a couple of inches. This will give you the clearance you need to raise and lower the wheel while sharpening.

Bevel Angle – With the jig attached to your drill press, you're ready to clamp your chisel or plane iron in place for sharpening.

This jig is designed to grind a 30° bevel (approximately). In order to set up your tool for grinding at this angle, all you have to do is position

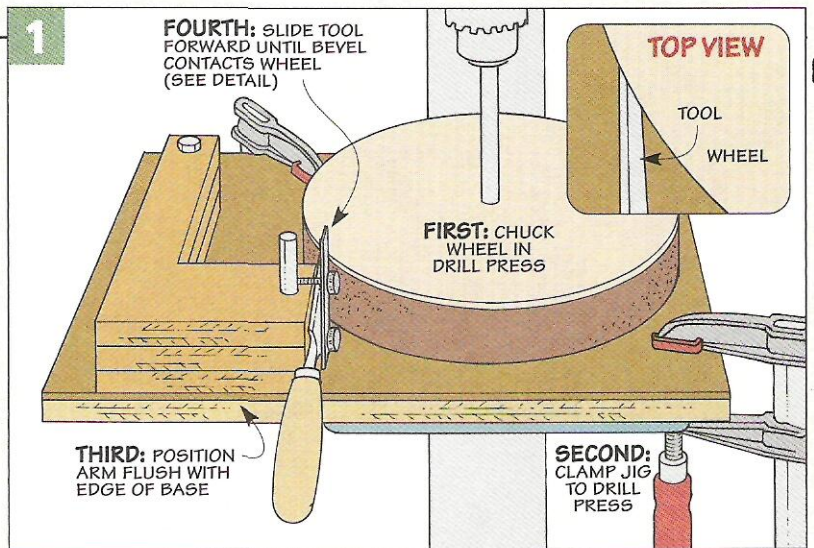

the arm so that the front edge is flush with the front edge of the base, just as you see in Figure 1. Then insert the tool under the clamp plate, resting on the tool support. Now slide it forward until the bevel just contacts the wheel.

Finally, tighten down the thumb screws to hold the tool in place.

That's all there is to it. (If you wish to change the bevel angle slightly, all you have to do is slide the tool forward or back a little bit before clamping it in place.)

Sharpening

Sharpening a tool with this jig couldn't be much easier. All you have to do is hold the tool against the wheel with gentle pressure while moving the wheel up and down.

There are just a few things to keep in mind. First, make sure that your drill press is set to run at its slowest speed. Second, keep the wheel

moving across the face of the tool while sharpening (Step 1). And you don't need to (and shouldn't) press the tool too hard against the wheel. Let the sandpaper do the work.

Honing – After you've sharpened the tool, charge the leather on the



wheel with rouge or honing compound, see photo in margin. Then you can hold the tool against the leather and strop the edge to a mirror-like polish (Step 2).



▲ **Honing Compound.** Before honing the edge of your tool on the wheel, charge the leather with honing compound.

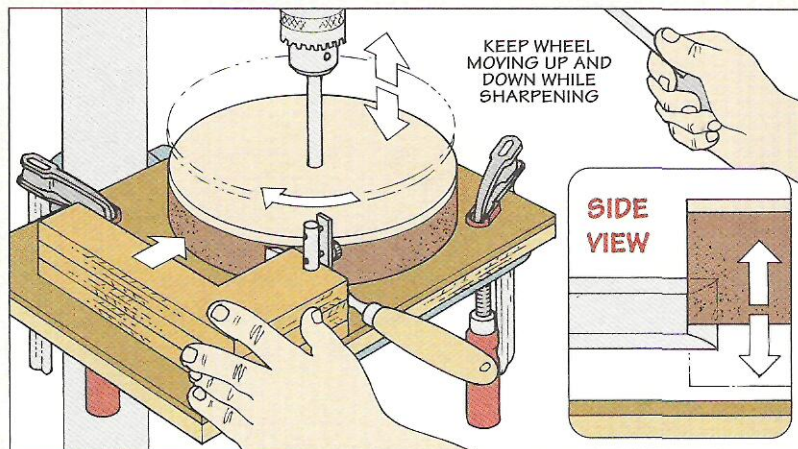

1 While lightly holding the tool against the revolving wheel, move the wheel up and down in a smooth motion. Check your progress frequently to make sure the tool isn't overheating.

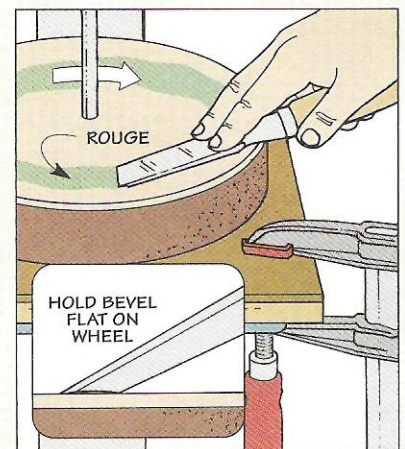

2 After charging the leather with honing compound, strop the edge until it shines like a mirror.

Tapping Threads

When making the Sharpening Jig (page 18) and Hand Plane (page 26), you'll need to drill a few holes and then tap them.

Tapping is nothing more than using a special tool that's designed to cut threads *inside* a hole. But don't worry if you haven't done this before. It's an easy process using the steps detailed below.

Layout – Start by marking the location of each hole. To keep the bit from wandering as you drill, you'll need to make a dimple with a metal punch, as seen in Step 1. Note: A scrap (or a pair) with a V-groove cut in it makes a handy holder.

Drill Hole – Now you're ready to drill the hole. The thing to keep in mind is that the final size of the hole should be slightly *smaller* than the diameter of the tap. This leaves enough material for the tap to cut the threads. (Note: Each tap has a

specific size "pilot" hole.)

Also, depending on the final hole size, it's a good idea to drill a series of progressively larger holes (Step 2). This prevents the bit from heating up and possibly breaking.

Since I was using a 10-32 tap, I started with a $\frac{3}{32}$ "-dia. drill bit and finished up with a $\frac{5}{32}$ "-dia. bit. Adding a drop or two of oil as you drill allows the bit to cut smoothly.

Chamfer – Before tapping the hole, there's one more thing to do. To help center the tap, I like to cut a slight chamfer in the rim of the hole, as illustrated in Step 3.

Tap Threads – Now you're ready to fit the tap in a T-handled wrench and add a few drops of oil to make it cut easier (Step 4).

To keep the tap from binding as you cut the threads, the goal is to start the tap straight. Then, with a little downward pressure, rotate

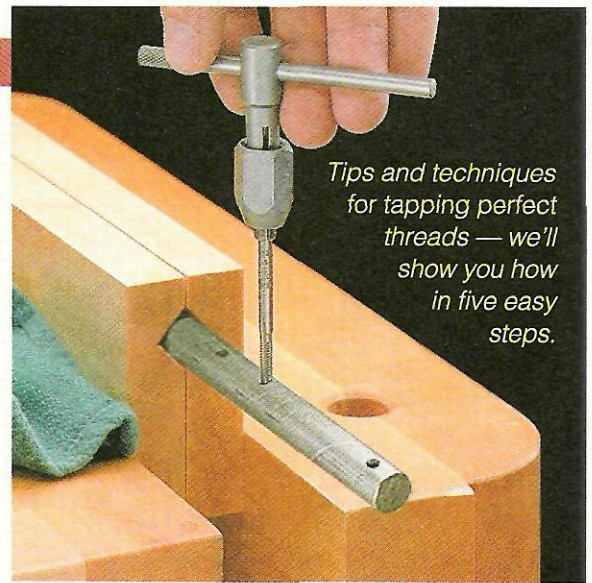

Tips and techniques for tapping perfect threads — we'll show you how in five easy steps.

the tap clockwise about a half-turn until it starts to cut (Step 5). After cutting a few threads, back the tap off to allow the waste to drop free.

Although it's tempting to cut the threads all the way down, you could stress the tap and break it. So it's best to only do a half-turn at a time until all the threads are cut.

Clean-Up – Finally, run the tap through the hole a couple of times to clean up the threads and clear away any remaining shavings. 

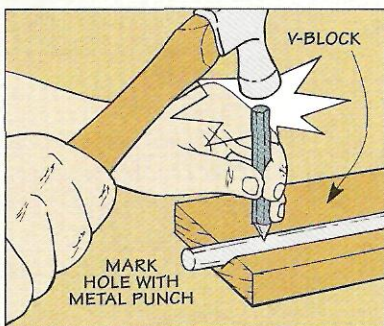

Step 1. To prevent the bit from wandering, use a metal punch to create a dimple in the rod.

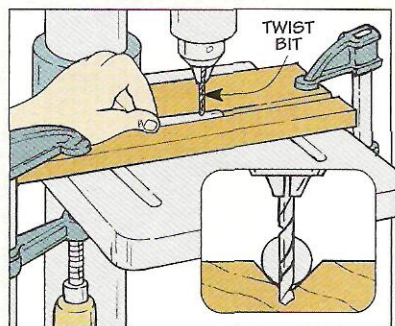

Step 2. Start by drilling a small hole. Then increase the hole size using progressively larger drill bits.

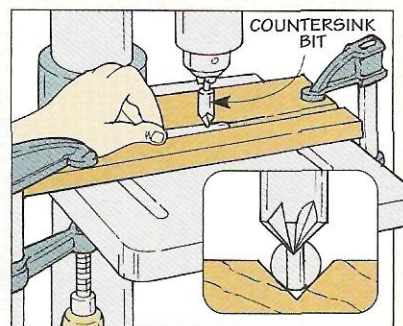

Step 3. To help center the tap, use a countersink bit to cut a slight chamfer around the rim of the hole.

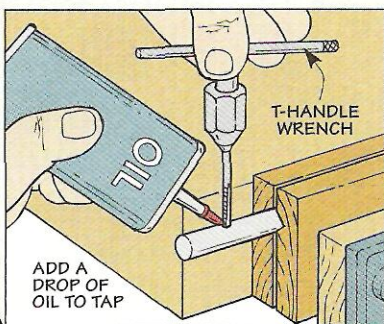

Step 4. Now position the tap so it's straight up and down. Then add a few drops of oil to the tap threads.

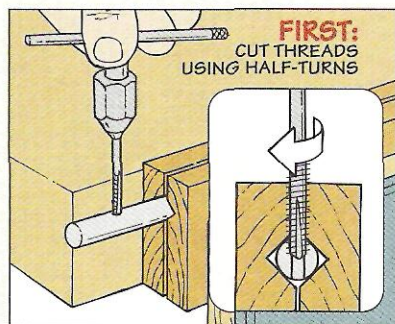

Step 5. With the tap straight up and down, begin cutting the threads (left). After each half-turn, back off the tap a quarter-turn to clear the waste (right). Then just repeat the process until the threads are cut all the way through.

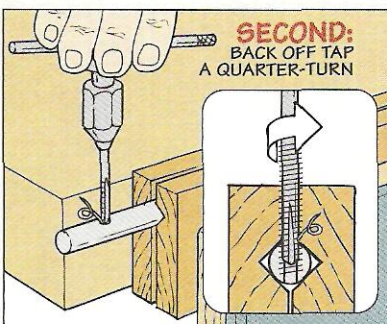

Adjustable Hand Plane

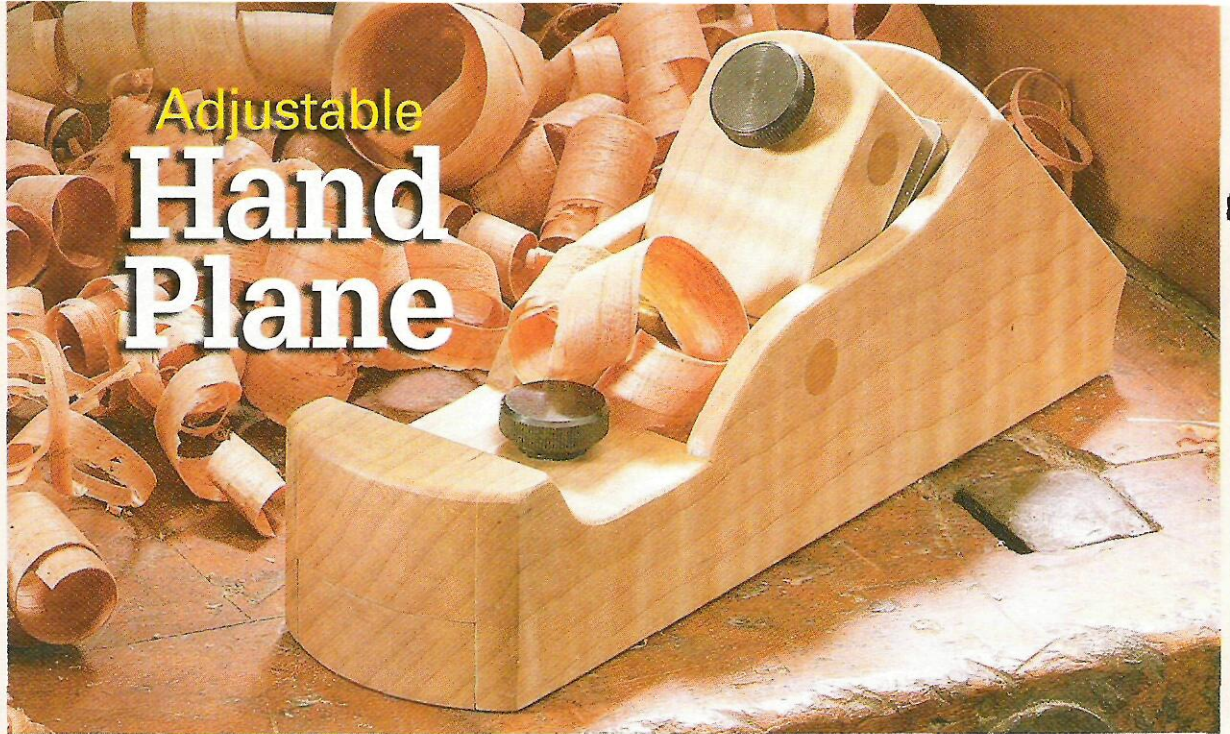

Nothing quite compares to the look and feel of freshly planed wood — unless of course it's the satisfaction of creating that surface with a hand plane you've made yourself.

But don't worry. Making the hand plane shown above isn't all that difficult. As you can see in the Exploded View below, there are only six pieces. In addition, the design improves on a couple things I've always found lacking in many wood planes.

Adjustable Throat Opening — First, there's an adjustable throat opening where the blade projects

through the bottom of the plane. So depending on whether you're making thick or thin shavings, adjusting the size of the opening is a snap.

Lever Cap — The other difference is how the blade is held in place. In most wood planes, a wood wedge holds the blade inside the plane. But I "borrowed" an idea from some of the metal planes I have and added a wood lever cap, as shown in the photo above.

Blade — These design improvements won't matter much if you don't have a good blade installed. So I used a 1½"-wide blade manufactured by the Hock Company. It's made of high-quality steel and holds an edge extremely well. (For sources, refer to page 35.)

Note: For a handy way to quickly sharpen plane blades and chisels, take a look at the Drill Press Sharpening Wheel on page 18.

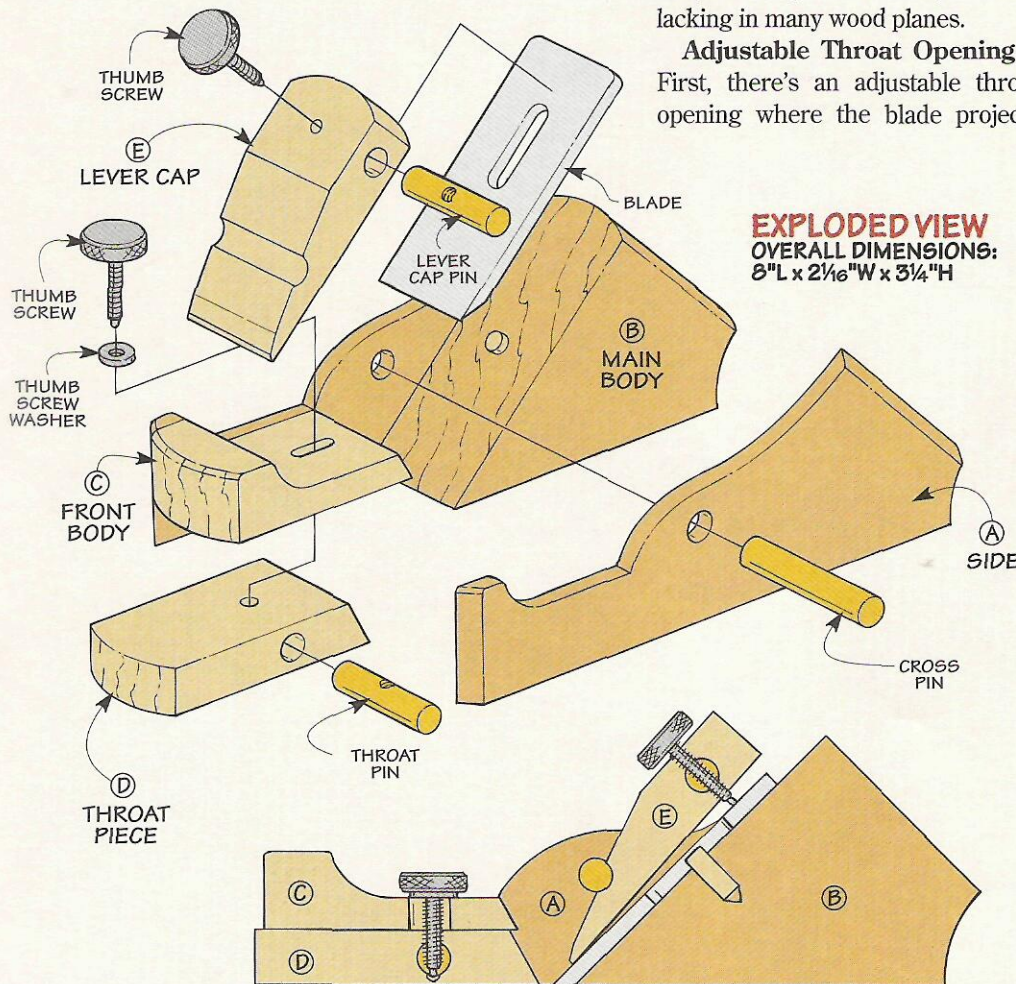

EXPLODED VIEW
OVERALL DIMENSIONS:
8" L x 2 1/16" W x 3 1/4" H

SIDES & MAIN BODY

I started on the hand plane by making the sides and main body.

As you can see in Figure 1, the sides (A) and main body (B) are cut to final width and thickness but extra-long. Then to make the pieces easy to align during assembly, I cut the back end of each piece at a 45° angle.

The only thing that's critical here is the thickness of the blank for the main body. Since I used a 1½"-wide

blade, I sized my blank to a thickness of $1\frac{9}{16}$ ". This way, there's just a little extra room to adjust the blade side-to-side during use.

All that's left to do before starting the assembly is to cut the main body to final length. To do this, I cut the front of the body at a 45° angle to match the back end. This provides a general-purpose cutting angle for the blade.

Assembly – Now, you're ready to start assembling the sides and main body. To make it easy to align these parts accurately, I found it best to assemble the plane one piece at a time. Besides making the assembly less hectic, it's easier to check that each piece is straight and square before you tighten the clamps.

Since the sole (bottom) of the plane rests on the workpiece during use, it's important to keep it as flat as possible. So I used the top of my table saw as a reference to align the bottom edges of all the parts.

To start the assembly, glue the main body to one of the sides first, as illustrated in Figure 1. Then clamp them together so they're flush along the back and bottom edges. While the glue dries, you can begin work on the pieces that make up the front of the plane.

Front Body & Throat – As you can see in Figure 2, the front of the plane consists of two pieces: a front body and an adjustable throat piece. The front body is glued in place between the sides — but the throat piece isn't. This way, you can slide the throat piece back and forth to vary the size of the opening in the bottom of the plane.

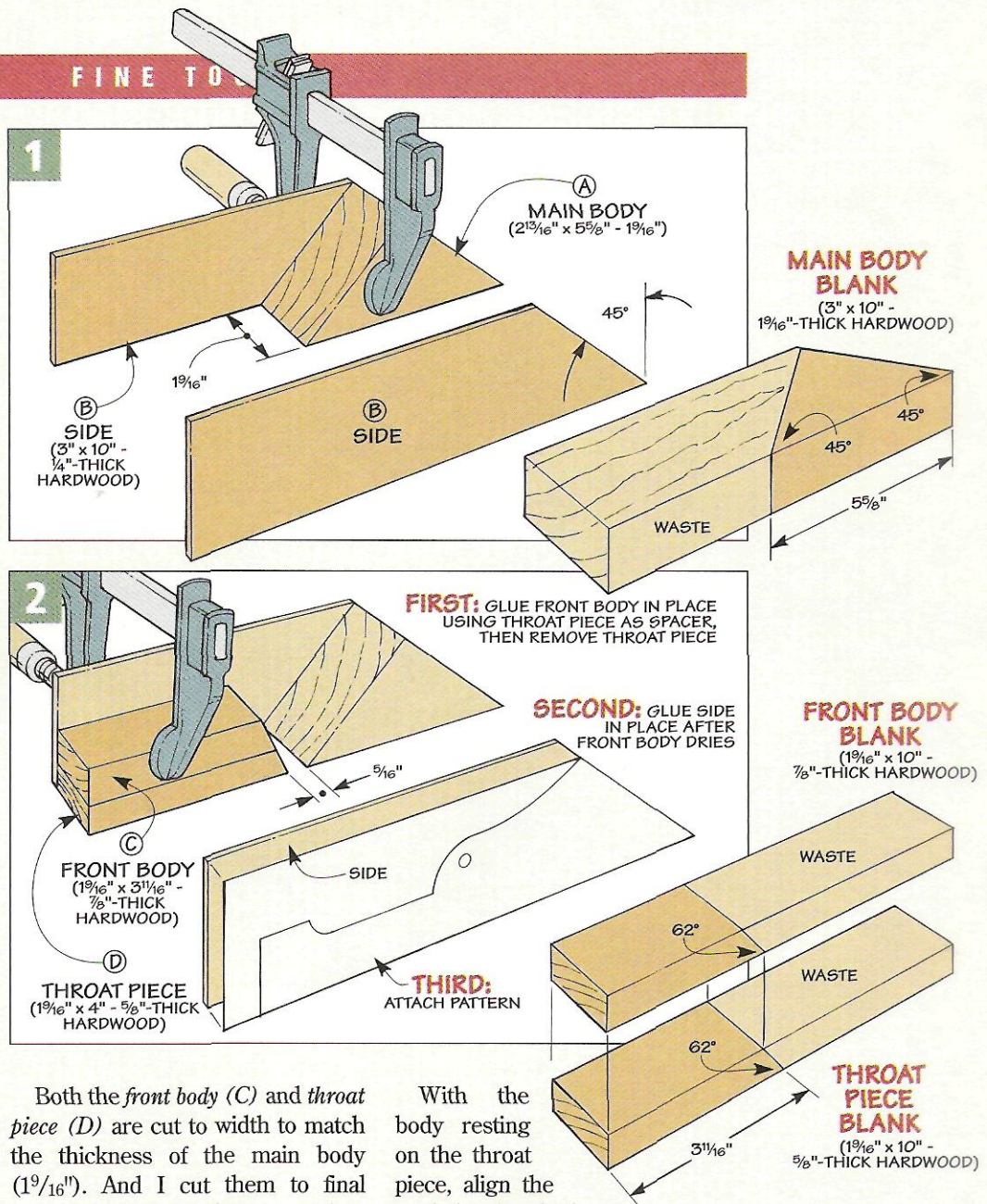

Both the front body (C) and throat piece (D) are cut to width to match the thickness of the main body ($1\frac{9}{16}$ "). And I cut them to final length with a 62° angle at one end, as shown in Figure 2.

With the pieces cut to size, you're ready to assemble the rest of the plane. The idea here is to use the throat piece as a spacer to raise the front body to the proper height as you glue it in place.

With the body resting on the throat piece, align the angled ends of both the front body and throat piece so there's a small gap ($\frac{5}{16}$ ") between the throat piece and main body. This is where the blade will come through the sole of the plane.

After clamping the front body in place, remove the throat piece. Then once the glue is dry, you can attach the other side piece.

Pattern – Finally, I used spray adhesive to attach the pattern shown at left to the side of the plane (Figure 2). Besides using the pattern to shape the plane later, it also helps to accurately locate the cross pin that's used to hold the lever cap in place. (Note: You'll need to enlarge the pattern 200%.)

PATTERN (ENLARGE 200%)

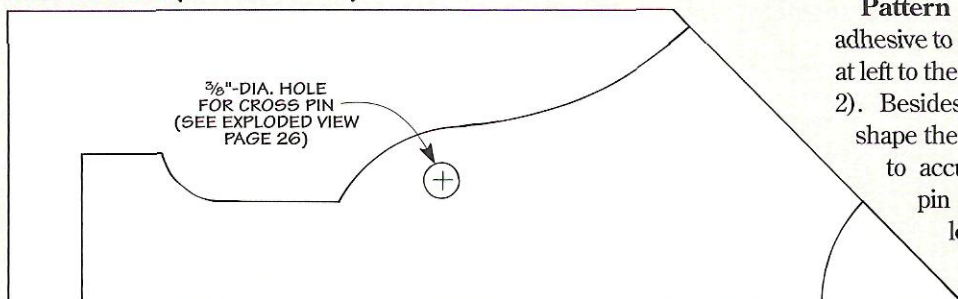

Shaping the Body

Now that the basic plane has been formed, you're ready to cut it to rough shape and smooth the edges. Then you can add the hardware for the throat piece that allows you to adjust the opening for the blade (see margin).

Cut to Rough Shape – Since the pattern is already in place, cutting the plane to rough shape is just a matter of staying within $1/16$ " of the line on the band saw, as shown in Figure 4.

To do this, I made a series of cuts starting at the top of the plane. Then to complete the shaping, I made a cut flush with the top of the front body and eased the back end of the plane by removing a pie-shaped piece.

The band saw can leave a rough edge, so I used a drum sander in the drill press along with a sanding

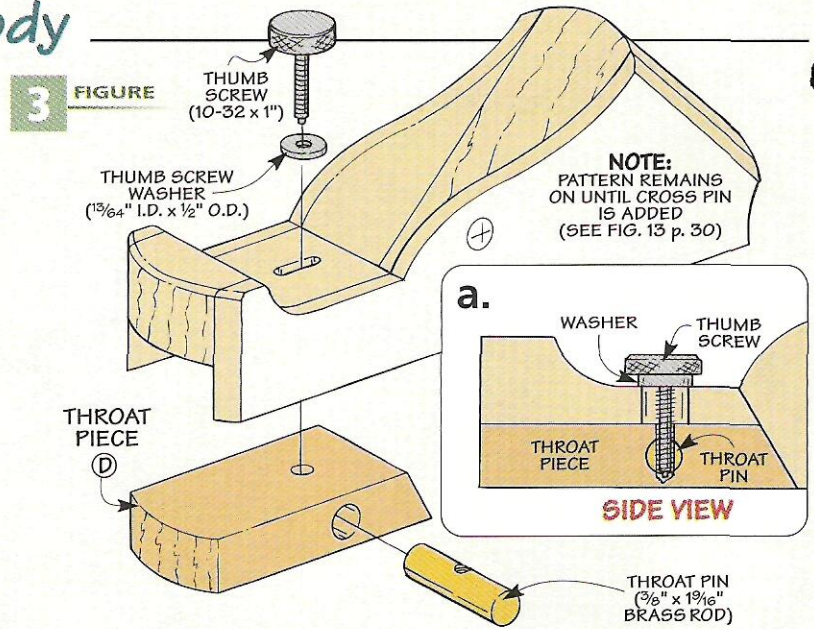

▲ Adjustable Throat.
To accommodate the thickness of the shaving, the throat opening can be adjusted easily.

block to sand up to the line and smooth out any rough spots.

To complete the basic shape, there are two more things to do. And that's to shape the front and back of the plane for a more comfortable grip.

Shape Front – Here again, I used the band saw to remove the waste at the front of the plane (Figures 5 and 5a). To keep the throat piece in place as you do this, run a strip of tape across both the throat piece and front body of the plane.

Shape Back – Shaping the back of the plane with the band saw can be a problem. That's because there isn't a flat surface for the plane to ride on. So instead, I shaped a comfortable grip on the back using a rasp and files, as shown in Figures 6 and 6a.

To hold the plane steady while you work, it's a good idea to clamp it in a vise with wood jaws. Then once you've removed most of the waste, sand both ends smooth. An easy way to do this is to use a strip of sandpaper and "buff" the plane as if you are shining a pair of shoes.

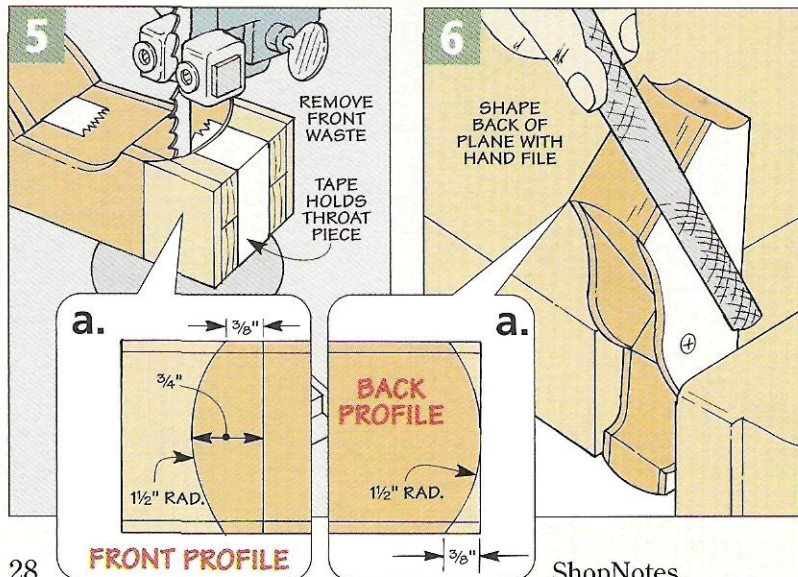
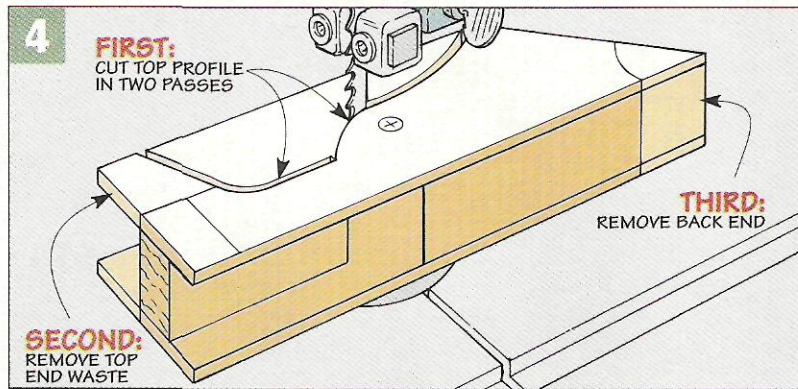

THROAT PIECE

Once you have the plane shaped and sanded, you can turn your attention back to the throat piece. Although it's now at final size, you still need a way of allowing it to slide back and forth, yet still lock firmly in place.

To do this, there's a brass rod installed in the throat piece (Figure 3). Threads tapped through the rod allow it to accept a thumb screw that passes through a slot cut in the top of the plane. As you tighten the thumb

Hardware

- (1) $3/8$ " x $1/2$ " Brass Rod
- (1) $3/8$ " x $19/16$ " Brass Rod
- (1) $3/8$ " x $2/16$ " Brass Rod
- (2) 10-32 x 1" Thumb Screws
- (1) $13/64$ " I.D. x $1/2$ " O.D. Flat Washer
- (1) $1/2$ "-wide Hock Blade

screw, the throat piece is pulled up tight against the plane (Figure 3a).

Create Slot – The first step is to cut the slot. To do this, start by drilling a series of holes (Figures 7 and 7a). To avoid chipout on the bottom of the slot, I like to slip a scrap in place of the throat piece. Once the holes are drilled, use a chisel to clean up the sides of the slot.

Having the slot complete makes it easy to locate the hole in the throat that the thumb screw fits into. First, slip the throat piece in place so it's aligned at the front and back. Then feed the drill bit through the slot so it's centered and drill a hole into the throat piece (Figure 8).

Just be sure to stop short of the bottom, as you can see in Figure 8a. Although a hole won't affect how the plane works, it's nice to have a smooth sole without any holes in it.

Brass Rod – The next step is to locate the brass rod that acts as a "nut" for the thumb screw. Locating the hole for the rod is just a matter of transferring the centerline of the hole you just drilled in the top of the throat piece to the side (Figure 9).

After transferring the location, drill a $\frac{3}{8}$ "-dia. hole for the brass rod (Figures 9 and 9a). Before installing the rod, you'll need to tap some threads for the thumb screw.

To locate the hole for the threads, I found it easiest to start with an extra-long piece of brass rod and slip

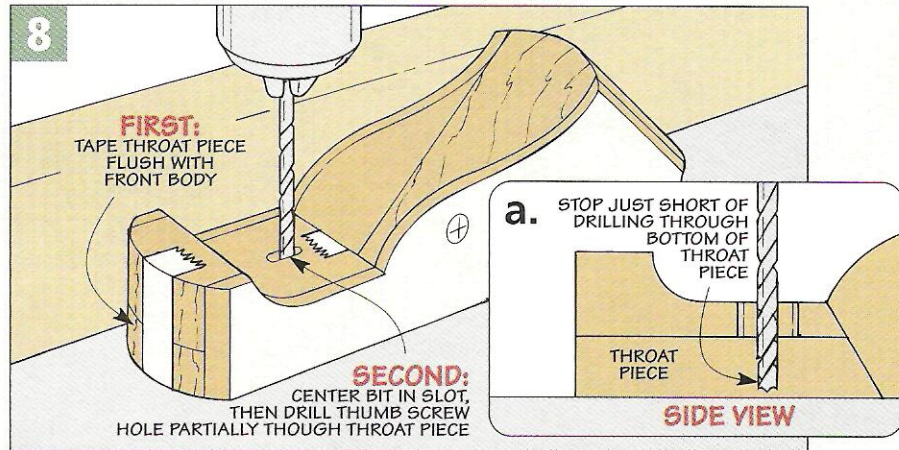
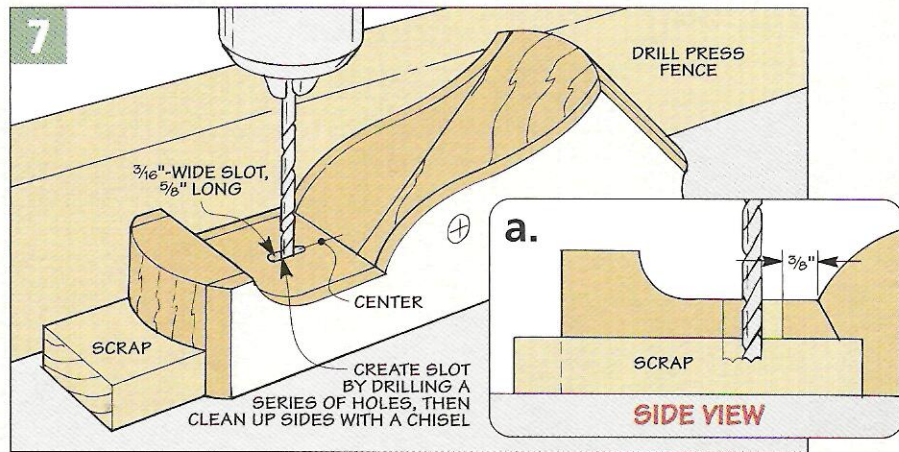

it in place so it was flush at one end. Then I used the hole in the top of the throat piece as a guide to lightly mark the location of the hole on the rod (Figures 10 and 10a).

After removing the rod, drill and tap the hole. (For more on tapping holes, refer to page 25.)

With the threads complete, you can cut the brass rod to length and press it in place (Figure 11). As you do this, make sure the holes in the rod and throat piece are aligned (Figure 11a). Finally, file and sand the ends of the rod so they're flush with the sides of the throat piece.

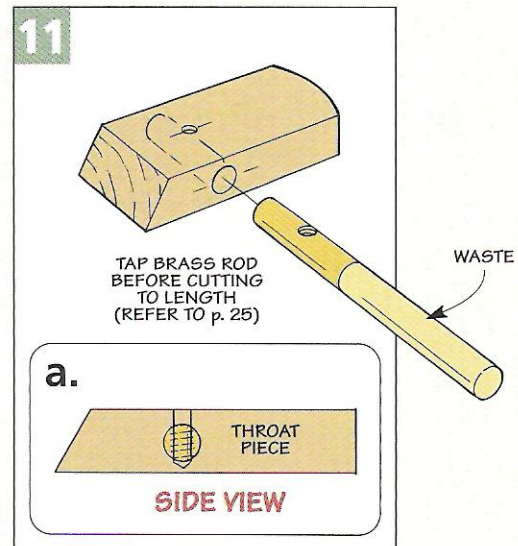
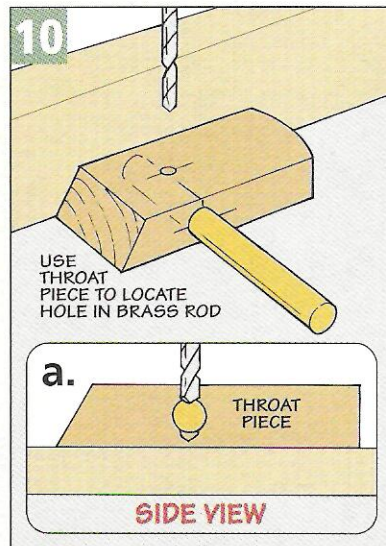
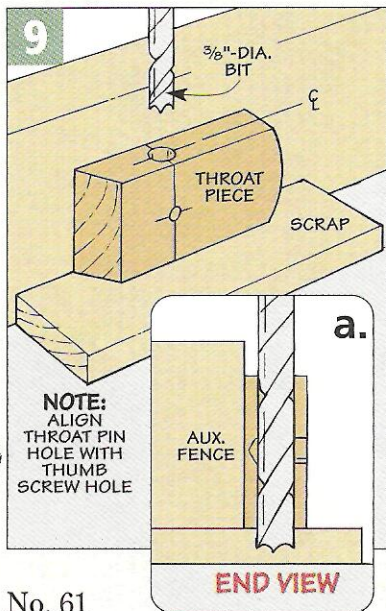

Lever Cap

In many wood planes, the blade is held in place with a wedge-shaped piece of wood. It's no different here, but instead of driving a wedge in place, I "borrowed" an idea from one of my metal planes — a lever cap.

As you can see in Figure 12 and the Side Detail, turning a thumb screw causes the lever cap to pivot around a cross pin in the body of the plane. This causes both the lever cap and thumb screw to lock the blade firmly in place. Plus, it makes adjusting the blade an easier process.

Cross Pin – Before getting started on the lever cap, I took a minute to complete the body of the plane so I could add the cross pin.

Unlike the pin in the throat piece, there isn't any hole to drill or tap. All you need to do is cut the rod to length and slip it through a pair of holes drilled in the sides of the plane.

Drilling the holes isn't difficult. But to avoid chipout, I slipped a scrap in place to provide solid support (Figures 13 and 13a).

Lever Cap – With the holes drilled, you're ready to make the lever cap (E). Here again, the lever cap is rather small to work with. So it's a good idea to start with an extra-long blank cut to final width and thickness.

12 OVERVIEW

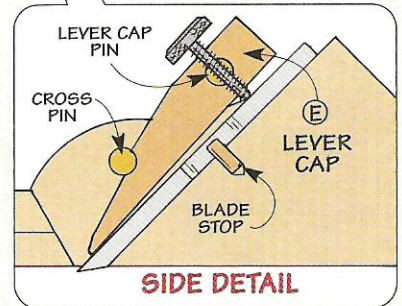
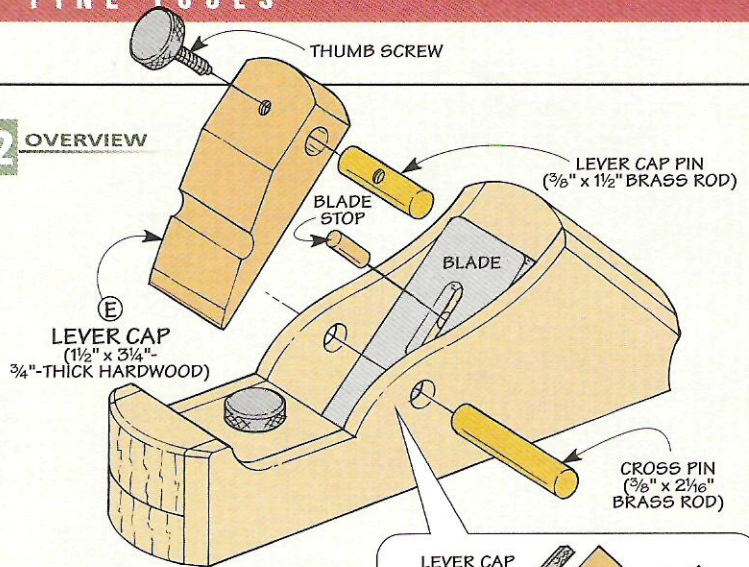

The long blank makes it easier to drill a pair of holes in one end of the blank (Figures 14 and 14a). One hole is for a brass rod that's threaded to accept a thumb screw. The other hole will become a notch that fits around the cross pin installed in the body.

After the holes are drilled, you're ready to cut the wedge shape. To do this, you'll need to make *three* separate cuts, as you can see in Figure 15.

Just be sure not to remove too much as you make the second cut near the tip. The goal is to trim (and sand) just enough so the lever cap barely slips under the cross pin.

Once the lever cap fits, you can shape the curved end. Then cut a

piece of brass rod to length and slip it in place. Finally, to accept the thumb screw, drill and tap both the brass rod and lever cap (Figures 16 and 17).

Blade Stop – One thing I noticed during the fitting of the cap is that the blade had a tendency to slide out the bottom of the plane each time you loosened the lever cap. To prevent this, I added a blade stop.

▲ **Lever Cap.** Unlike a typical wood plane, the blade is held in place by a wood lever cap and thumb screw.

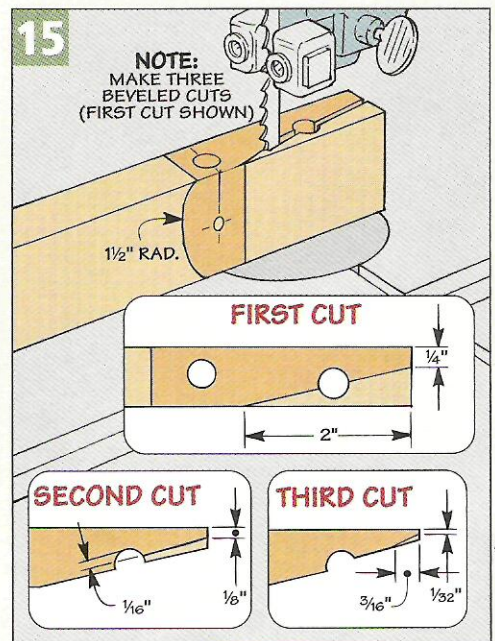
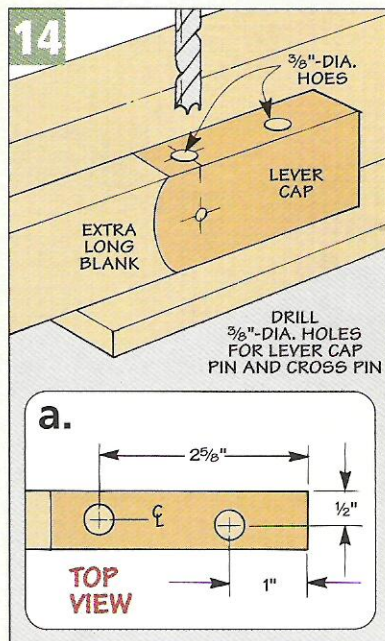
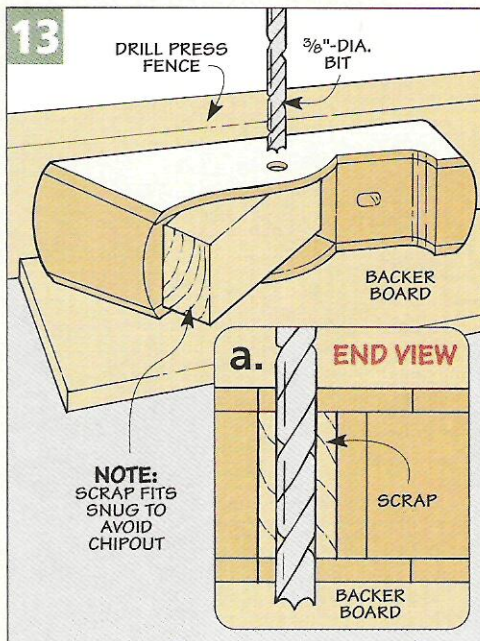

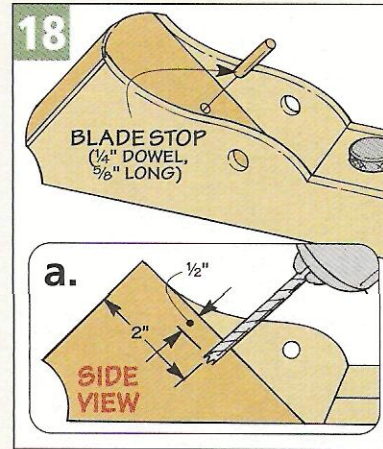
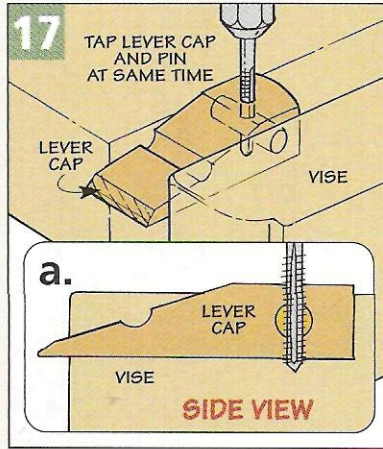
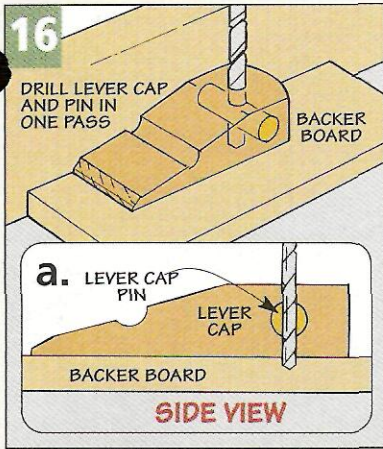

The stop is nothing more than a short length of dowel that fits into a hole drilled in the body (Figures 12 and 18). (I used a hand drill to do this.) The dowel “catches” the top of

the slot in the blade before it has a chance to slide all the way out.

What’s important here is that the top edge of the stop rests below the surface of the blade. This way, it

won’t interfere with the lever cap.

At this point, the plane is almost ready to use. But before you start, take a little time to fine tune it, as shown in the box below. 

Tune-Up & Adjustment

Before using any plane, it’s a good idea to do a little adjustment and fine tuning. This isn’t difficult, it just takes a little time.

True Sole – To ensure that the plane rides evenly across the workpiece for a

smooth consistent cut, you’ll need to true the sole of the plane so it’s perfectly flat.

To do this, I use sandpaper and a flat surface, as shown in Step 1. Note: Sand the plane with the blade installed (make sure

it’s pulled back slightly). This will “stress” the body of the plane like it is in use.

Adjust Cut – Once that’s complete, all that’s left to do is adjust the plane to make paper-thin shavings (Steps 2 through 4).

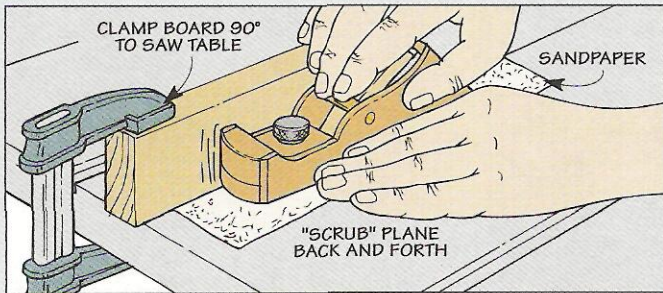

1 To flatten the sole, “scrub” the bottom across a piece of sandpaper attached to a flat surface. A board clamped 90° to the saw table prevents the plane from rocking.

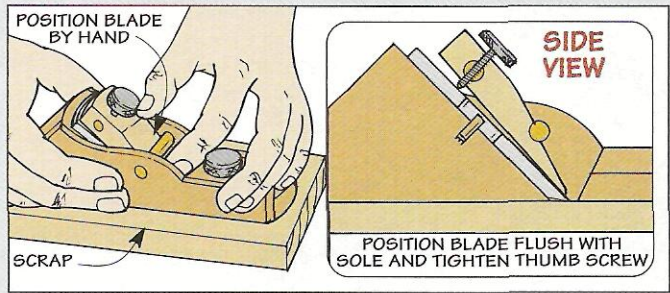

2 Once the sole is flat, reposition the blade so the cutting edge is flush with the sole. After tightening the knob to hold the blade in place, narrow the throat opening (1/16”).

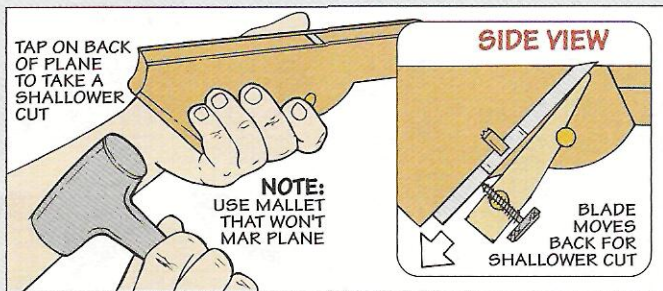

3 After making a trial cut, you may need to adjust the depth of cut. For a shallower cut, tap the back of the plane with a mallet. For a deeper cut, tap the front body.

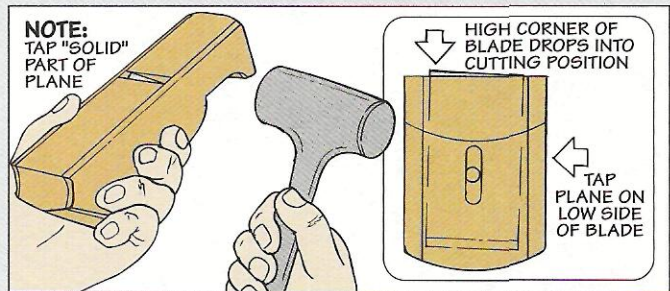

4 To maintain a consistent depth of cut, the cutting edge should be parallel with the sole. Striking the opposite side of the “high” corner drops the blade into cutting position.

Shop Talk

Right tilt or left? When it comes to table saws, which one is “right?”

It used to be cut and dried. When choosing a table saw, the saw blade tilted left or right depending on the manufacturer of the saw. Many tool companies like *Delta* made their saws so the blade tilted to the right. Others companies, like *Powermatic* and *Sears Craftsman*, had saws where the blades tilted to the left. The only choice you had was which brand of saw you bought.

But lately things have gotten a bit more complicated. Several manufacturers are now offering two different models of saws — one that tilts right, the other that tilts left.

So now you have a choice and a decision to make. But before you do, I've put together a few things you might want to consider. Plus I've included some information that you can put to use even if you don't plan on purchasing a new table saw.

First of all, what makes a saw a left tilt or right tilt? As you face the saw, the tilt corresponds to the location of the arbor assembly, as you can see in

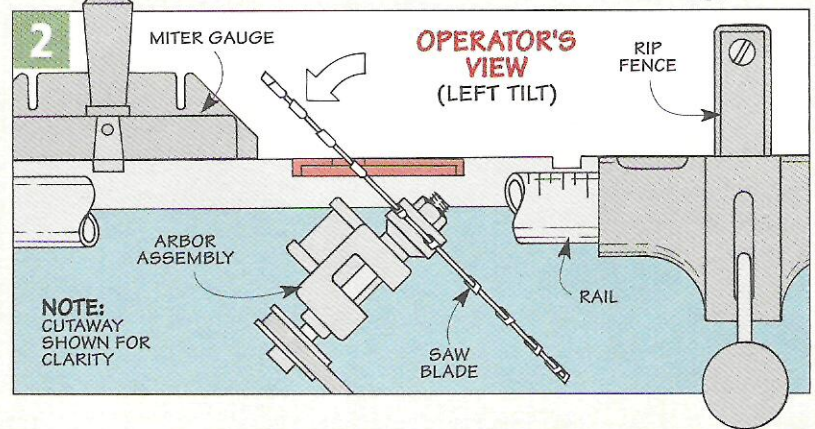
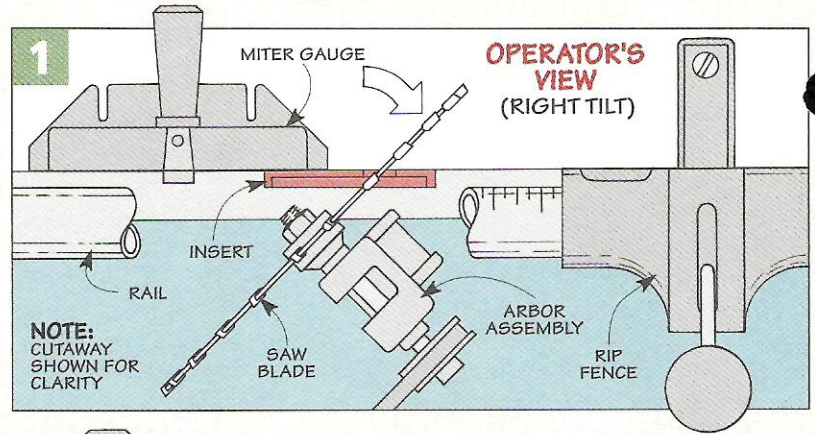

Figures 1 and 2. So on a right-tilt saw, the arbor assembly is on the right. And vice-versa for a left-tilt saw. So when does this make a difference?

Beveled Crosscut – Well, one of the most tilting operations that requires tilting the blade is when you need to cut a bevel on the end of a workpiece. To make this cut you need to use the miter gauge. And when you do, it's a good idea to have the blade tilting *away* from the miter gauge. This way, when the waste piece is cut free it will rest on the saw

table and not on top of the spinning blade. So depending on which way the blade tilts you'll have to approach this cut differently.

If the blade tilts to the right, the miter gauge is placed to the left (Figure 3). In this position the miter gauge is held with the right hand and the work piece with the left. Since this is the way I typically make a crosscut, it feels perfectly natural for me.

However, if the blade tilts to the left (Figure 4), the miter gauge should be on the right side of the

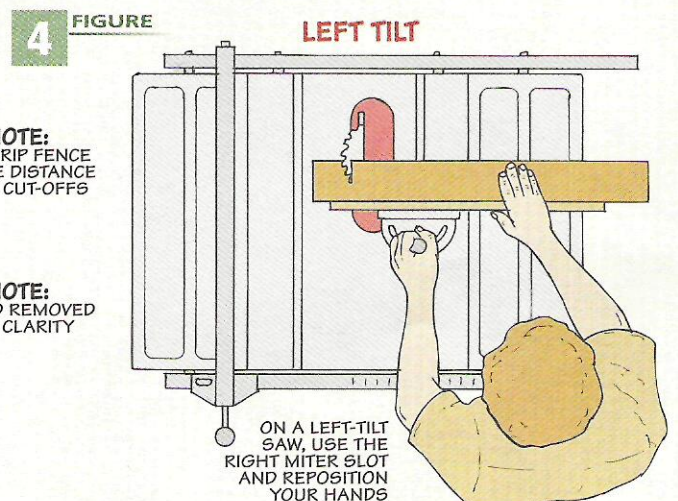
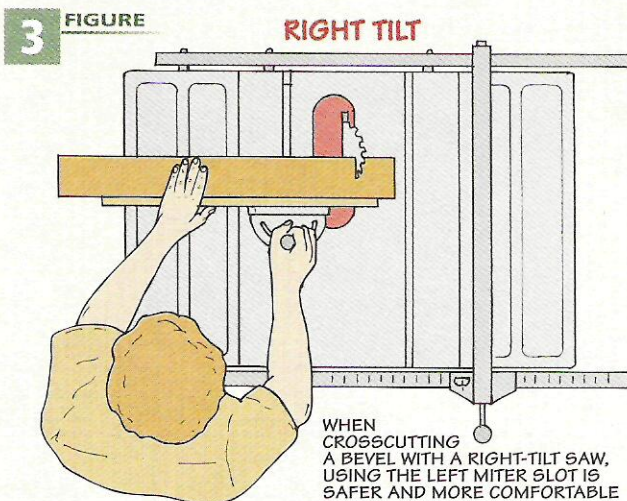

blade. Now the miter gauge is held with the left hand. This may feel a bit awkward the first few times you try it, especially if you're right handed.

With that said, I still wouldn't make my decision on a right- or left-tilt saw based only on making beveled crosscuts. The other thing that needs to be considered is what happens when you need to rip a bevel down the edge of a workpiece.

Ripping a Bevel – Whenever you make a rip cut with the blade tilted you need to think about the relationship between the blade and the rip fence. I prefer to rip a bevel with the blade tilting away from the fence.

There are a couple of reasons for this. First, this puts the long point of the bevel (and the face that's most likely to be seen) on the top side — where there's less chance of chipout. But more importantly, this is a safer way to make a bevel rip.

Let me show you why. In Figure 5, you'll notice that the workpiece is between the fence and the blade. Do you see how the piece is trapped? It can't move in any direction. If it raises off the table slightly or pulls away from the fence it will "wedge" itself tightly between the fence and the blade. As a result, it can bind, burn, or cause the workpiece to kick back.

Another problem is that on narrow cuts, the fence will interfere

with the blade guard. This makes it difficult, if not impossible, to use a push block safely.

On the other hand take a look at Figure 6 where the blade tilts away from the fence. Now if the piece raises up or pulls away from the fence, it will simply ride up the side of the blade.

Of course the result may be a cut that's not quite straight. But you have reduced the chance of any kickback. In my book, it's the safest way to go.

Here again, the direction the saw blade tilts may affect how comfortable you feel when making a rip cut.

To see why, take a look at Figure 7. If the blade tilts to the left, the fence remains to the right of the blade and you push the workpiece through with your right hand. So making a beveled rip cut isn't any different than any other rip cut.

On the other hand, if the saw blade tilts to the right, you'll want to move the rip fence to the left side of the saw blade (Figure 8). Now you'll have to push the workpiece through with your left hand, which may feel a little awkward once again.

There's one other thing to note here. The rails for most rip fences don't extend as far to the left of the saw as they do to the right. This means you'll have less ripping capacity when you position the rip fence to the left side of the saw blade.

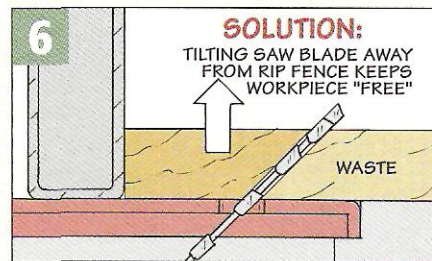
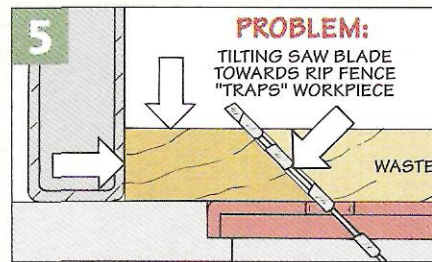

The "Right" Choice – Now that you know the differences and what you need to do when you make a rip or crosscut with a right- or left-tilt saw, what's the "right" choice?

In the end, it's really up to you. So if you're thinking about investing in a new table saw, it would be worthwhile to do a little bit of testing. Here's what I'd recommend.

With the saw off and the blade lowered, make a few "pretend" crosscuts with the miter gauge on each side of the blade to see what's more natural. Then repeat the process by making a few rip "cuts" with the fence on each side of the blade.

Once you've done that, you'll have a good idea whether you're more comfortable with a right- or left-tilt table saw — and therefore which one is the "right" choice for you. 🛠️

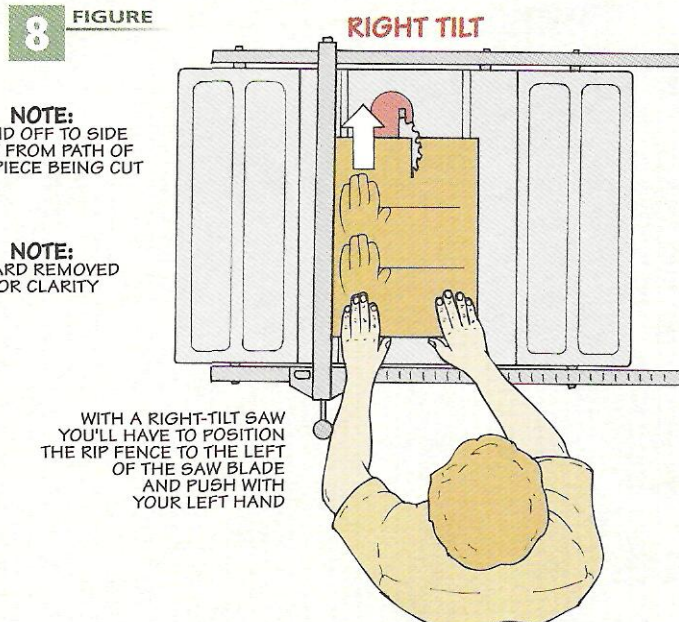
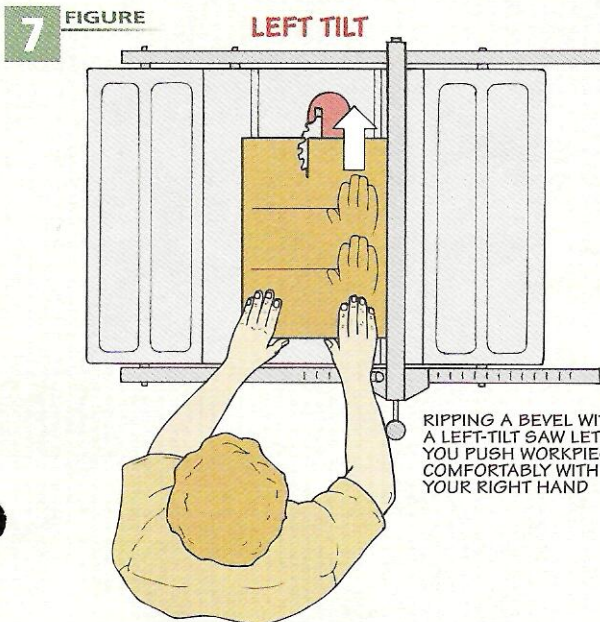

Tool Chest

Looking for a scraper that can really get the job done? These carbide blade scrapers are a cut above the rest.

Let's face it. There's nothing glamorous about scraping paint. The quicker it's over the better. Unfortunately, most of the scrapers I've tried just can't get the job done.

Then one day I came across a scraper that changed all that. It was made by *Sandvik*. And I still remember the first time I tried it. As I pulled the tool across the surface, the old, dried and cracked paint came off in a shower of chips, leaving a swath of clean, bare wood behind. I was impressed. Finally, a scraper that actually worked the way it should.

Well I've been using that same scraper for over ten years now. Naturally, it's looking a bit rough and worn, but it still works as well as the day I bought it. Since then I've picked up a couple of other *Sandvik* scrapers as well — a larger model with a knob on the head and a smaller version for getting into tight spots. You can see all three models above.

So what makes these scrapers so good? Well let's start with the blade. It's a solid piece of carbide. So it stays sharp longer than any steel blade could. If the carbide cutting edge does become dull, all you have to do is flip the blade around to expose another sharp cutting edge. How long does the carbide blade stay sharp? Well, one person here at

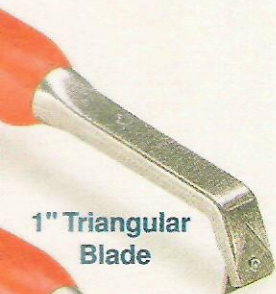

1" Triangular Blade



2"-Wide Straight Blade



2 1/2"-Wide Straight Blade

Sources

- Amazon.com
www.amazon.com
- Highland Hardware
800-241-6748
- Lee Valley
800-871-8158
- Rockler
800-279-4441
- Woodsmith Store
800-835-5084

ShopNotes scraped his entire house with a *Sandvik* scraper, using only one edge of the blade. He still hasn't turned the blade around. But if you really do a lot of scraping, replacement blades are available.

Another thing that sets these scrapers apart is their practically indestructible design. They feature a one-piece, cast-metal head and neck. On the two larger models the carbide blade is held in place with a metal plate that is screwed into the head. On the smaller scraper, the blade is screwed directly to the head. The system works so well that in over ten years I have never had a single blade slip or loosen up.

Finally, to make the task of

scraping as pleasant as it can be, each scraper is fitted with a large, comfortable grip that's as durable as the rest of the tool.

As you can tell, I think these tools are top-notch, and they have earned a permanent place in the *ShopNotes Tool Chest*. If you're thinking about adding a *Sandvik* scraper to your tool chest, I would recommend starting with the mid-size scraper. It has a 2"-wide blade and is my favorite. One last thing — buying a good tool doesn't always mean spending a lot. These scrapers only cost between \$15 and \$20.

Note: You may find *Sandvik* scrapers under the name *Bahco* in some catalogs. 

New-Style Scraper

As I was working on this article, I came across a new-style scraper from *Sandvik*. It features the same carbide blade as the old style shown in the top photo at left. With this scraper the blade only mounts to the front of the head. It comes with one triangular-shaped blade, but other blade shapes are available. I found the small size of this

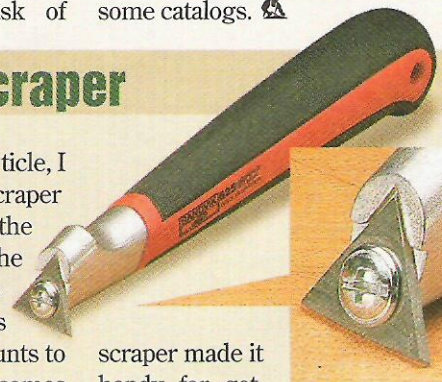

scraper made it handy for getting into tight spaces. As an added bonus, it comes with a holster that attaches to your belt.

Sources

PRODUCT INFORMATION



▲ Knobs & Toilet Bolts

All that's necessary to attach the various accessories to the router in the 5-in-1 Router Base Plate System shown on page 6 is the few pieces of hardware shown above. *ShopNotes Project Supplies* is offering a hardware kit that contains two star knobs, toilet bolts, and washers. Call 1-800-347-5105 to order.

HARDWARE KIT

6853-125.....\$6.95



▲ Honing Compound

Putting a razor-sharp edge on a chisel or plane blade is fast and easy with the Drill Press Sharpening Wheel (page 18). Especially when you charge the leather on the top of the wheel with a honing compound. It cuts quickly yet still leaves a mirror finish on the chisel or blade.

- Highland Hardware. 800-241-6748
- Lee Valley 800-871-8158
- Woodsmith Store ... 800-835-5084



▲ Spiral Router Bits

To cut a mortise using the Mortising Jig shown in the 5-in-1 Router Base Plate System (page 6), we found that a spiral *upcut* router bit produced a clean cut with little (if any) tearout. These bits are available in a number of sizes (including the 1/4" bit shown here). To reduce vibration, we recommend using 1/2"-shank bits. Spiral router bits are available from most woodworking stores or the mail-order sources below.

- Jesada 800-531-5559
- Woodcraft 800-225-1153
- Woodsmith Store ... 800-835-5084

Project Kits ON THE WEB

Get ShopNotes
Kits Quick
Visit us on the Web at
ShopNotes.com



▲ Drill Press Sharpening Wheel

Most of the hardware for the Drill Press Sharpening Wheel shown on page 18 can probably be found at your local hardware store. But a few items might be a little more difficult to locate.

The thumb screws used to lock the blade or chisel in the carriage were obtained from *McMaster-Carr* (Part No. 90079A225). And we used 1 1/2"-wide sandpaper rolls (220-grit) from *Klingspor* (Part No. SR81178).

One item you might be able to find locally is the leather that's attached to the wheel. We bought a vegetable-tanned tooling belly (3 - 5 oz. weight) at a local leather company. You can also check with the *Tandy Leather Company*. We've included their phone number (and those for *McMaster-Carr* and *Klingspor*) below.

- Klingspor (Strip Sandpaper) 800-645-5555
- McMaster-Carr (Thumb Screws) 630-833-0300
- Tandy Leather Company (Leather) 888-890-1611

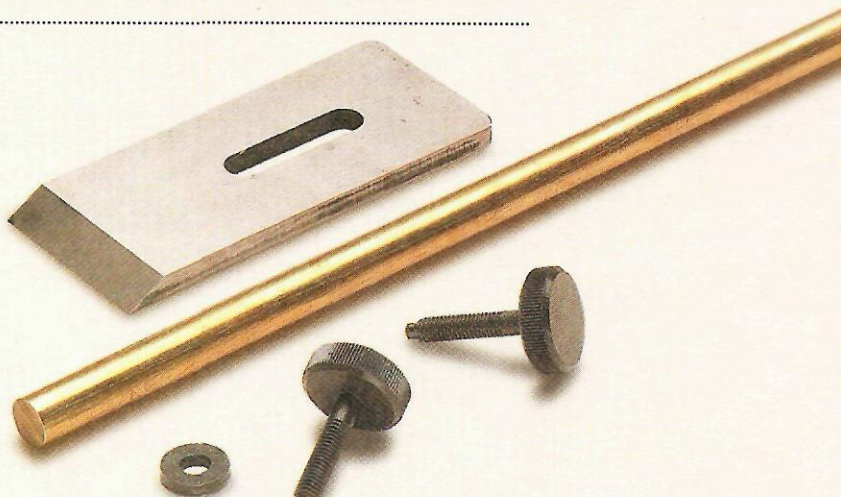

▲ Hand Plane Hardware

Like the Sharpening Wheel, some of the hardware used to make the Hand Plane on page 26 might be a little hard to locate. We did use the same thumb screws (Part No. 90079A225). And we added a hardened steel washer (Part No. 98029A011) from *McMaster-Carr*. But finding a local source for the 3/8"-dia. brass rod might take some time. So we've provided a mail-order source for that below.

The 1 1/2"-wide Hock blade we used is a little easier to come by. It's available from *ShopNotes Project Supplies* by calling 1-800-347-5105 and requesting Part No. 5005304 (\$28.95). You can also order it with a chip breaker (which isn't required for our design) from *Japan Woodworker* (Part No. 53.001.6).

- Japan Woodworker (Plane Blade) 800-537-7820
- McMaster-Carr (Thumb Screws & Washer) 630-833-0300
- Small Parts Inc. (Brass Rod) 800-220-4242

Scenes from the Shop



FLUSH TRIM JIG

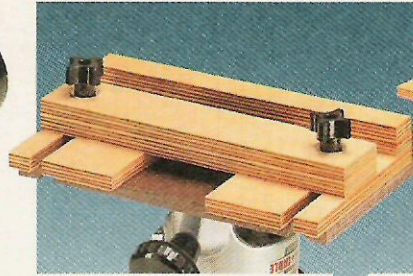

MORTISING JIG

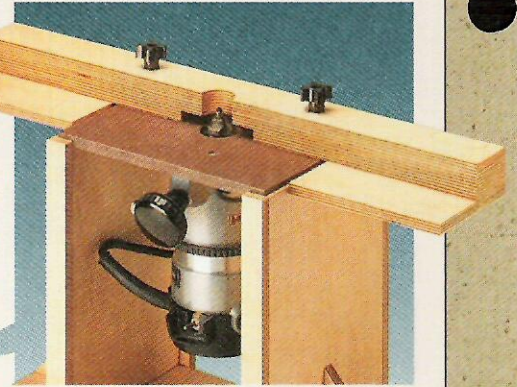
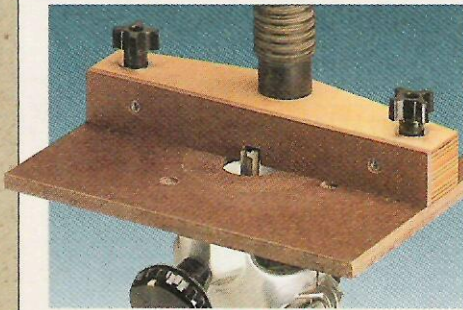
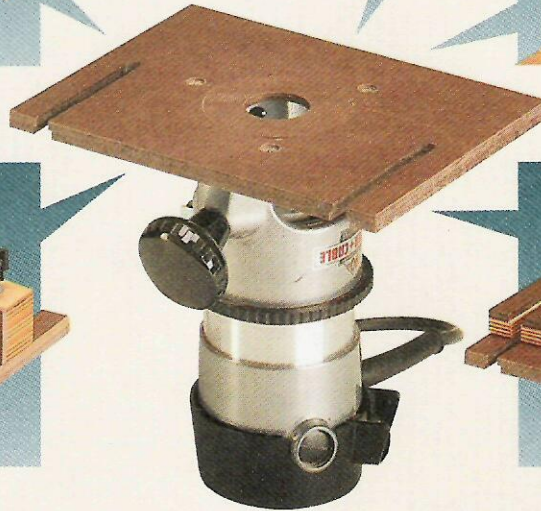

TABLE & FENCE



EDGE GUIDE



CIRCLE CUTTER

▲ Here's a quick-change router system that will stretch the capabilities of your router. The custom base plate provides a larger surface area for better support. Plus,

there are five must-have accessories that work great and can be changed in a snap. Step-by-step plans for the base plate and accessories begin on page 6.

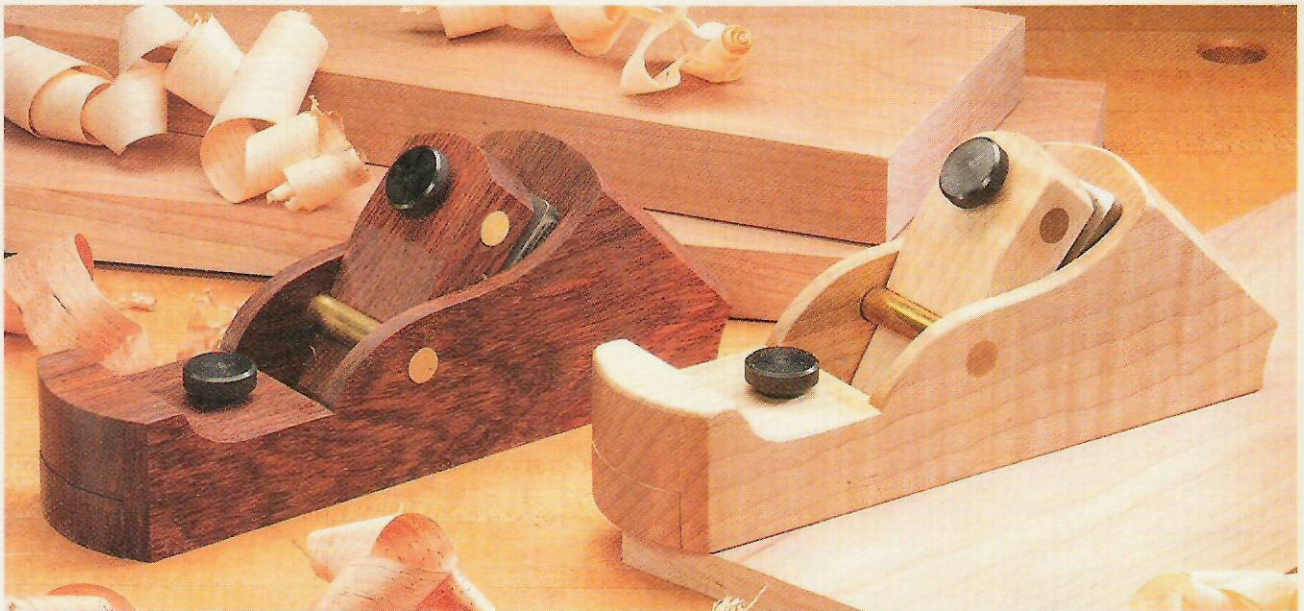

▲ Sure, these hand-built planes look elegant. But they're also hard workers, with some of the same features you'd find on traditional metal planes. And whether you use

an exotic wood (left) or a piece of highly-figured wood (right) you been saving for something special, making the plane is easy with the plans starting on page 26.