

ALL NEW
Wall-Mounted
Clamping Station

HAND ROUTING — SHOP SECRETS REVEALED

ShopNotes®

Vol. 11

Issue 62

Easy-to-build

BOX JOINT JIG

FOR YOUR TABLE SAW



1992-2002



**ALSO
INSIDE**

► **Learn the Secrets
to Perfect Glue-ups**

► **Classic Carpenter's Toolbox
with a Refined Design**

www.ShopNotes.com

DISPLAY UNTIL MAY 21, 2002

\$4.95US \$5.95CAN



0 74470 02994 6



ShopNotes®

Issue 62

March 2002

PUBLISHER Donald B. Peschke

EDITOR Terry J. Strohman

ASSOCIATE EDITORS Bryan Nelson
Vincent Ancona

CONTRIBUTING EDITORS Joel Hess
Craig Ruegsegger

ART DIRECTOR Cary Christensen

SR. GRAPHIC DESIGNER Kurt Schultz

SENIOR ILLUSTRATORS Roger Reiland
Mark Higdon

CREATIVE RESOURCES

Creative Director: Ted Kralieck • *Project Developer:* Ken Munkel
• *Sr. Project Designers:* Kent Welsh, Ryan Mimick • *Project Designer:* Chris Fitch • *Shop Craftsmen:* Steve Curtis, Steve Johnson • *Senior Photographer:* Crayola England

SPECIAL PUBLICATIONS

Corp. V.P.: Douglas L. Hicks • *Art Director:* Douglas A. Flint • *Sr. Graphic Designer:* Chris Glowacki • *Graphic Designer:* Vu Nguyen • *Associate Editor:* Craig Ruegsegger • *Asst. Editors:* Joel A. Hess, Joseph E. Irwin

CIRCULATION

Subscriber Services Director: Sandy Baum • *New Business Dir.:* Wayne J. Klingbeil • *Circulation Marketing Analyst:* Kris Schlemmer • *Assoc. Circ. Marketing Analyst:* Paula DeMatteis • *Renewal Manager:* Paige Rogers • *Sr. Graphic Designers:* Mark Hayes, Robin Friend • *Billing & Collections Mgr.:* Rebecca Cunningham • *Multimedia Promotion Mgr.:* Rick Junkins • *Promotion Analyst:* Patrick Walsh

CORPORATE SERVICES

V.P. of Finance: Mary Scheve • *Controller:* Robin Hutchinson • *Sr. Acct.:* Laura Thomas • *Accts. Payable:* Mary Schultz • *Accts. Receivable:* Margo Petrus • *Prod. Dir.:* George Chmielarz • *Electronic Pub. Dir.:* Douglas M. Lidster • *Network Admin.:* Cris Schwanebeck • *P.C. Maint. Tech.:* Rob Cook • *Pre-Press Image Specialists:* Troy Clark, Minnette Johnson • *Office Mgr.:* Noelle Carroll • *New Media Mgr.:* Gordon C. Gaippe • *Multimedia Art Dir.:* Eugene Pedersen • *Web Server Admin.:* Carol Schoeppler • *Web Content Mgrs.:* David Briggs, Sue M. Moe • *Web Designer:* Kara Blessing • *Prof. Dev. Dir.:* Michal Sigel • *H. R. Asst.:* Kirsten Koelle • *Receptionist:* Jeanne Johnson • *Mail Room Clerk:* Lou Webber

MAIL ORDER

Operations Director: Bob Baker • *Customer Service Mgr.:* Jennie Enos • *Warehouse Supr.:* Nancy Johnson • *Buyer:* Linda Jones • *Admin. Asst.:* Nancy Downey • *Tech. Rep.:* John Audette • *Cust. Serv. Team Leader:* Tammy Truckenbrod • *Sr. Cust. Serv. Reps.:* Anna Cox, Deborah Rich • *Cust. Serv. Reps.:* April Revell, Valerie Riley, Eddie Arthur • *Warehouse:* Sylvia Carey, Sheryl Knox

WOODSMITH STORE

Manager: Dave Larson • *Asst. Mgr.:* Tim Thelen • *Sales Staff:* Wendell Stone, Jim Barnett, Larry Morrison, Gregory Kauzlarich, Mark Johnson, Joe Kucera • *Office Mgr.:* Vicki Edwards

ShopNotes® (ISSN 1062-9696) is published bimonthly (Jan., March, May, July, Sept., Nov.) by August Home Publishing, 2200 Grand, Des Moines, IA 50312.

ShopNotes® is a registered trademark of August Home Publishing ©Copyright 2002 by August Home Publishing. All rights reserved. Subscriptions: Single copy: \$4.95. One year subscription (6 issues), \$27.95. Canada/International add \$10 per year; U.S. funds.

Periodicals Postage Paid at Des Moines, IA and at additional mailing offices.

Postmaster: Send change of address to ShopNotes, P.O. Box 37103, Boone, IA 50037-2103.

Subscription Questions? Write to: ShopNotes Customer Service, P.O. Box 842, Des Moines, IA 50304-9961. Or call 1-800-333-5854, 8:00 am to 5:00 pm, Central Time, weekdays. FAX 515-283-0447

E-Mail: ShopNotes@shopnotes.com

Internet: http://www.shopnotes.com

PRINTED IN U.S.A.

EDITOR'S NOTE

Cutoffs

Have you ever stopped in the middle of building a project and heard a small voice say, "If only this joint would fit better," or "I wish this jig was easier to use?" When this happens I've found it's a good idea to pay attention to that voice.

The reason is simple. Quite often the inspiration for a new project comes about when you're wishing for a better, safer, or more efficient way of building a project.

The Box Joint Jig (page 4) is the end result of listening to that voice and then making small yet significant improvements.

First, to get a precise fit, we wanted to eliminate any racking in the jig. Second, we wanted to reduce the amount of set-up time involved when making different size box joints.

Box Joint Jig—Our new Box Joint Jig has an easy-to-build, dual-runner system, which prevents racking and any side-to-side movement.

But what I like best about this jig is what you *don't* have to do — readjust it. A system of replaceable fences means that setup is now a one-time deal — no matter what size box joint you're making.

Clamping Station — Another project in this issue started out as a simple wish, "I wish I didn't have to clear my bench to glue-up a panel."

The answer to that wish is the Wall-Mounted Clamping Station on page 24. Not only did we reclaim workbench space, but we did away with having to wrestle with individual clamps — the clamps are built-in.

To top it off, the entire project only uses common materials and a minimum amount of hardware.

Help Wanted

One final note. We're looking for an editor to join us here at August Home Publishing. If you're enthusiastic about woodworking or home improvement and enjoy working as part of a team, we'd like to hear from you. Send a cover letter and a resume highlighting your experience to M. Sigel, 2200 Grand Ave., Des Moines, IA 50312. Email: msigel@augusthome.com.

Terry

Be included, as a part of the Woodworking Shop Tours

On the Web

Visit other ShopNotes subscribers' workshops and see photos of the shop projects they've built. It's all online at Woodworking Shop Tours on the ShopNotes web site:

www.ShopNotes.com

We want you to be part of our shop tours! To submit photos of your favorite ShopNotes projects or views of your shop, just follow the instructions you'll find on our web site.



Contents

Features

Box Joint Jig _____ 6

Unlike most box joint jigs, this one uses runners in both miter slots to make an extremely smooth-working jig. And replaceable fences allow you to make different size box joints without having to "retune" the fit.

Making Box Joints _____ 10

You can't help but appreciate the craftsmanship of precision box joints. Learn how easy it is to make them with our simple step-by-step approach.

Carpenter's Toolbox _____ 14

With its classic lines, solid wood construction, and strong box joints, this carpenter's toolbox will be around to use (and admire) for generations to come. It also features a removable tray for organizing small tools and hardware.

Great Glue-Ups _____ 20

There's more to creating a wide, solid-wood panel than just gluing a bunch of boards together. Learn the step-by-step process we use to glue up panels that look great and stay flat.

Clamping Station _____ 24

Glue up a panel without taking up valuable bench space? And without pipe clamps? This shop-built station makes it possible.

Departments

Readers' Tips _____ 4

Shop-tested tips to solve common woodworking problems.

Shop Talk _____ 32

We share the "secrets" used in our shop for creating a smooth, even profile with a router bit and a hand-held router.

Tool Chest _____ 34

Unconventional design, great results. Find out about an unusual bit that cuts perfect countersinks in wood or metal.

Sources _____ 35

Mail-order sources and supplies to help you complete the projects featured in this issue.

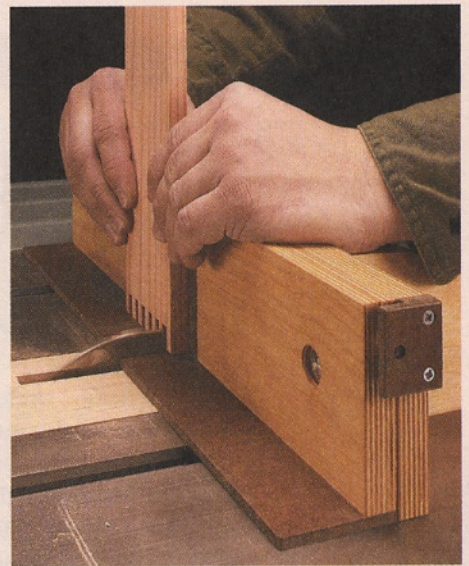

Box Joint Jig

page 6



Carpenter's Toolbox

page 14

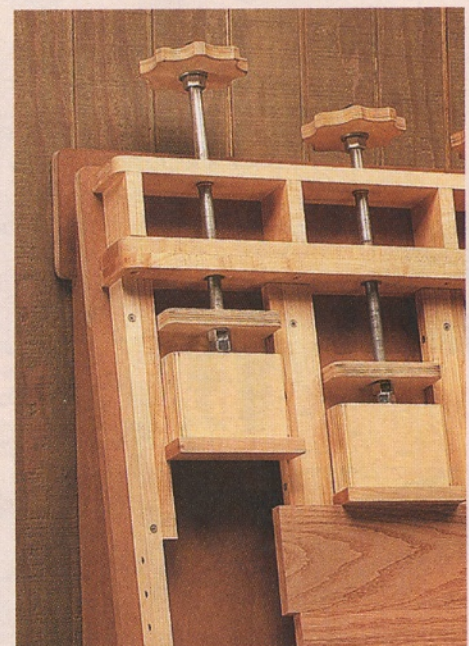

Clamping Station

page 24

Readers' Tips

Toggle Bolt Hold-Downs

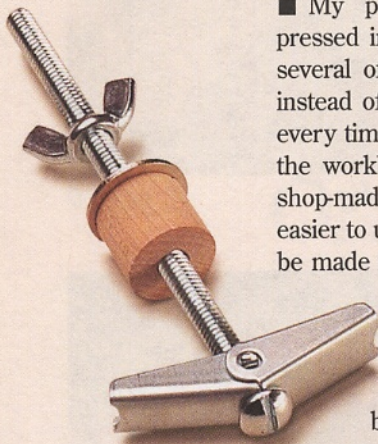

▲ **Hold-Downs.** The toggle bolts used for these shop-made hold-downs can be found at a local hardware store.

■ My portable workbench gets pressed into service as a stand for several of my benchtop tools. But instead of breaking out the clamps every time I want to attach a tool to the workbench, I came up with a shop-made hold-down. It's faster and easier to use than clamps, and it can be made from a few pieces of commonly available hardware and a wood dowel.

The hold-downs are made using a 1/4" toggle bolt, a washer, and a wing nut, see detail drawing at right.

The toggle bolt has a couple of wings that fold up, allowing it to be inserted through the holes in the top of the workbench. Once the wings pass through the hole, they spring open. To keep the toggle bolts centered in the holes of the workbench, I made some spacers for the bolts by drilling 1/4"-dia. holes through short lengths of 3/4"-dia. dowel stock.

The bolts pass through a plywood

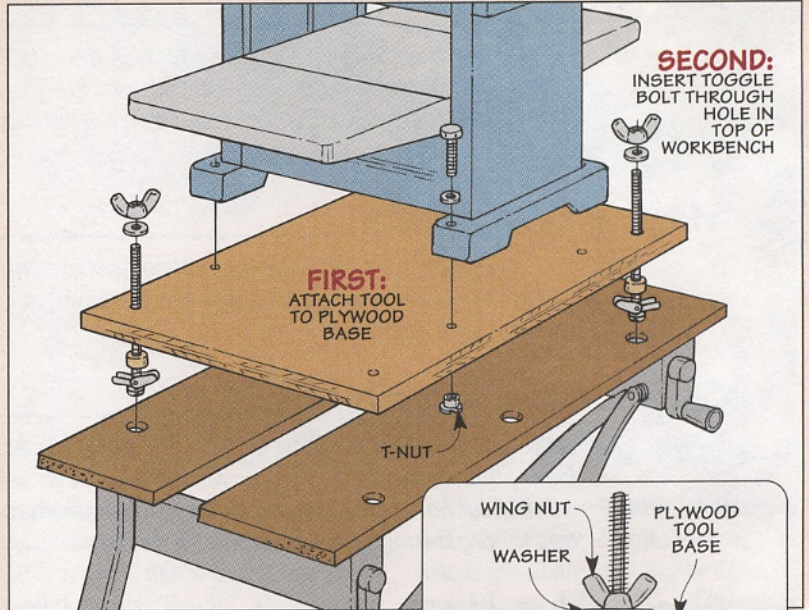

base on which the tool is mounted. All you have to do is tighten the wing nuts to hold the tool down to the top of the workbench.

*Dana Craig
Norwood, Massachusetts*

Pegboard Bit Holder

■ I built the Sliding-Door Wall Cabinet in issue No. 59. Since I had some pegboard left over from making the back of the cabinet, I

decided to put it to good use by making a router bit holder for one of the drawers of the cabinet. The bit holder can also sit on top of a shelf or workbench for easier access.

To make the holder, I simply cut a couple of pieces of the 1/4" pegboard to fit inside the drawer. Then I glued a pair of spacers in between the pegboard layers, taking care to keep the holes lined up, see drawing at right. Finally, I glued a piece of 1/8" hardboard to the bottom.

The holes in the pegboard are just the right size for my 1/4"-dia. router bits, see detail drawing at right.

*Deborah Vogt
Douglas, Alaska*

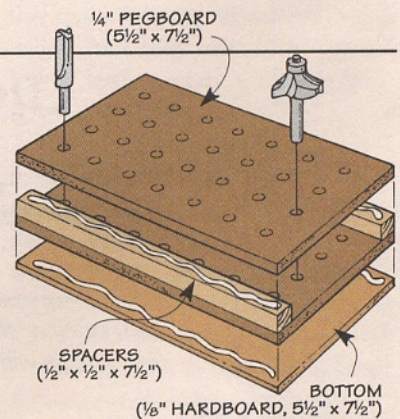

NOTE: USE SEVERAL BIT SPACERS TO KEEP PEGBOARD LAYERS ALIGNED DURING ASSEMBLY

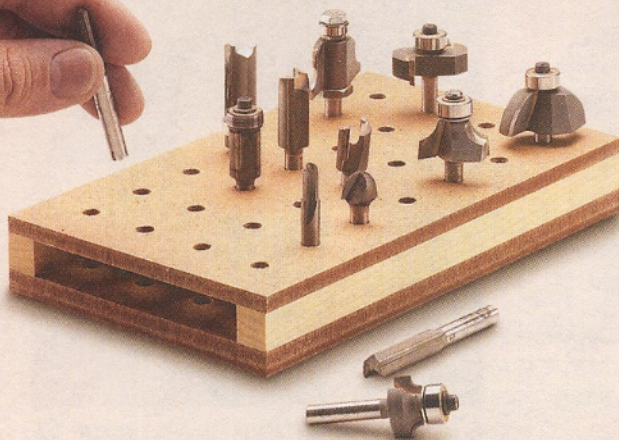
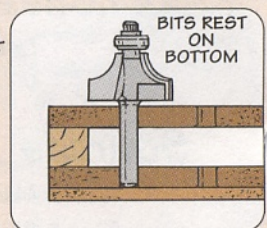

Quick Tips



▲ To keep track of his pencils, Robert Phardel, of Ortonville, MI, uses Velcro to attach the pencils to his drill press and other power tools around the shop.



▲ Scott Reichert, of Pittsburgh, PA, uses short lengths of rain gutter material to make convenient shelves for holding spray paint and other aerosol cans.

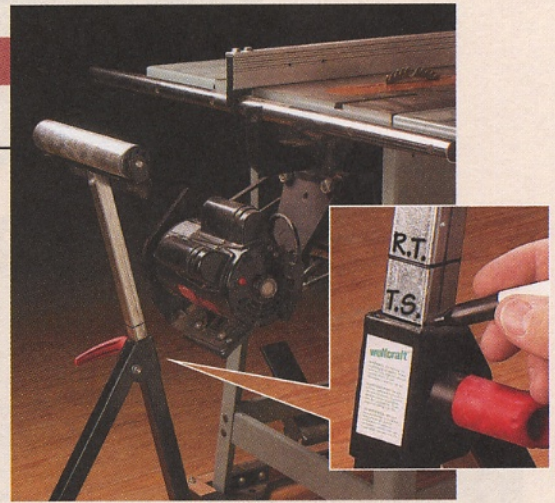

▲ To quickly adjust his outfeed roller, Jon Philips, of Fridley, MN, marks the arm to indicate the correct height for the different power tools in his shop.

Squaring Box Corners for Gluing

■ Whenever I'm assembling a box or drawer, I feel like I need two pairs of hands — one to hold the assembly square and another to apply the clamps. To make things a little easier, I came up with some squaring blocks to help hold the pieces square while I clamp them together.

I made my squaring blocks out of plywood. The base is just a square piece of $\frac{3}{4}$ " plywood. The top layer is actually made up of three separate pieces of plywood, see detail drawing at right. The trick is to glue these three pieces down squarely to the base so that the space in between them matches the thickness of the workpieces you are clamping up.

PLACE ONE SQUARING BLOCK UNDER EACH CORNER BEFORE ADDING CLAMPS

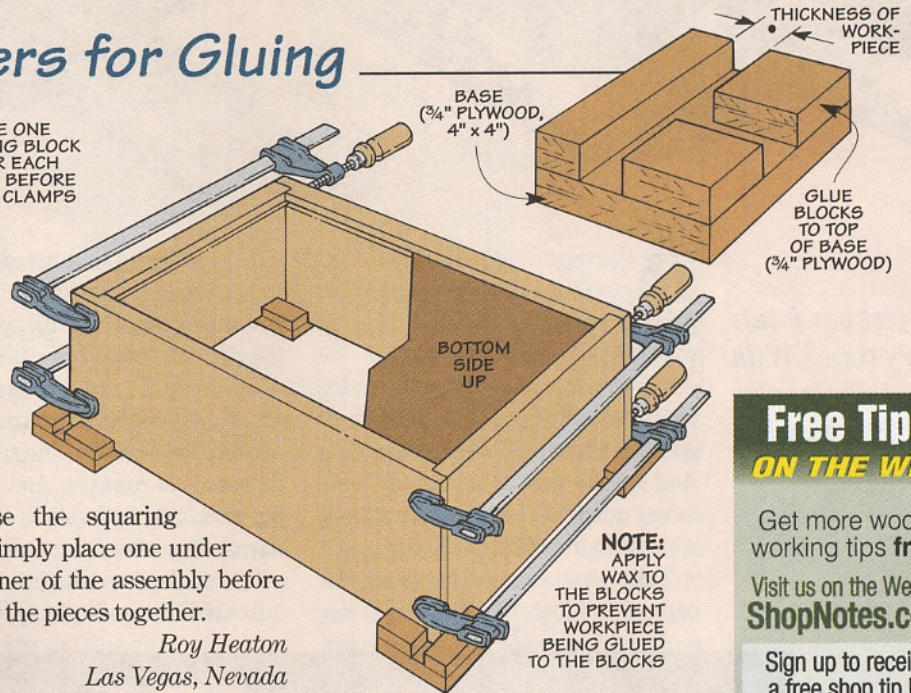

To use the squaring blocks, simply place one under each corner of the assembly before clamping the pieces together.

Roy Heaton
Las Vegas, Nevada

NOTE: APPLY WAX TO THE BLOCKS TO PREVENT WORKPIECE BEING GLUED TO THE BLOCKS

Free Tips ON THE WEB

Get more wood-working tips free.

Visit us on the Web at ShopNotes.com

Sign up to receive a free shop tip by email every week.

Paint Can Lid



■ Whenever I use a can of paint or finish, the liquid always runs from my brush into the groove around the rim of the can, making a mess when I replace the lid. To prevent this from happening, I cut a "donut" out of $\frac{1}{4}$ " hardboard and simply taped it down to the top of the can, see photo.

The donut keeps the finish out of the groove of the can and also provides a convenient place to wipe off the excess finish from my brush.

Melvin Kessler
Linden, Michigan

Send in Your Shop Tips

If you have a unique shop tip, we'd like to consider featuring it in one or more of our print or electronic publications.

We'll pay up to \$200 for a tip we publish. Just write down the tip and mail it to *ShopNotes*, Attn.: Readers' Tips, 2200 Grand Ave., Des Moines, IA 50312. Or FAX it to 515-282-6741, or send us an e-mail at shopnotes@shopnotes.com. Please include your name, address and daytime phone number in case we have any questions.

Box Joint Jig

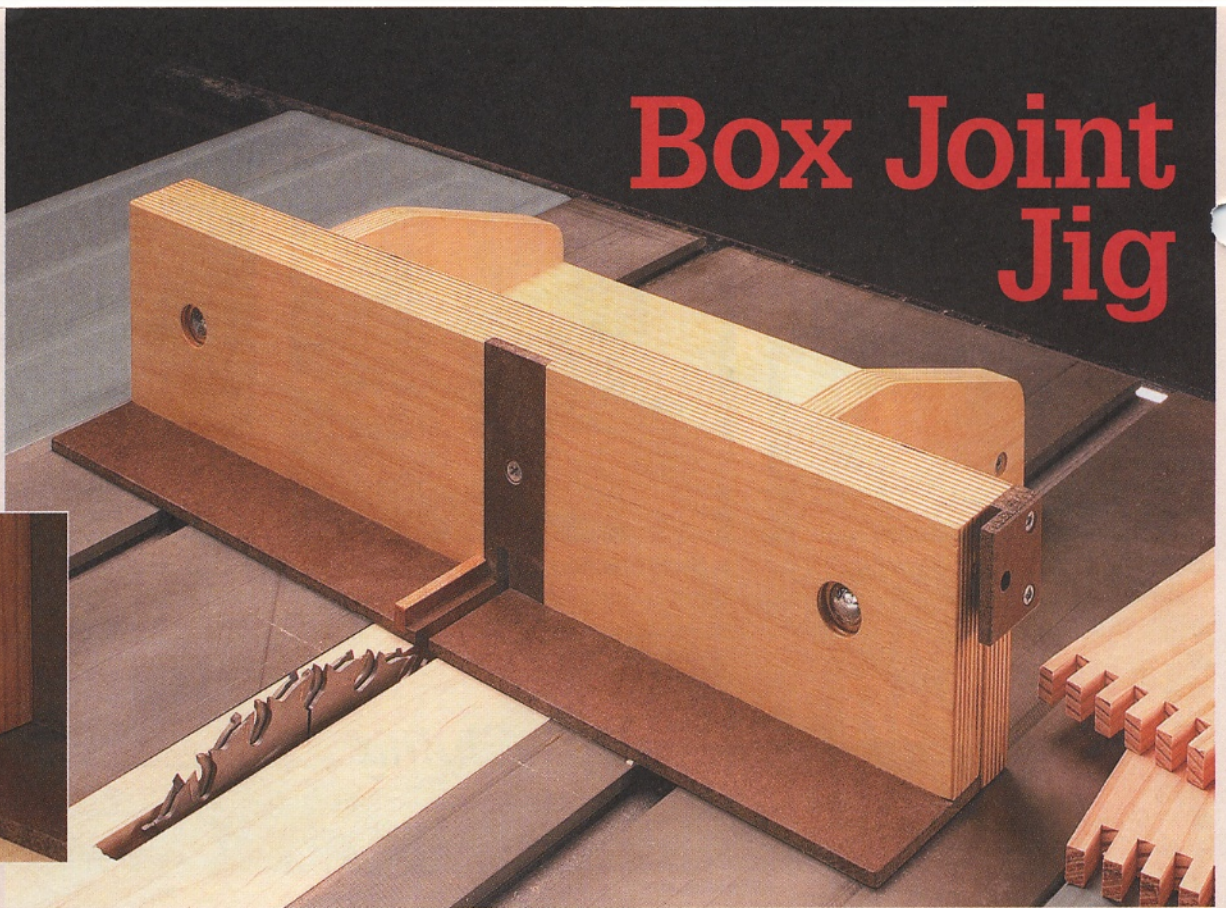
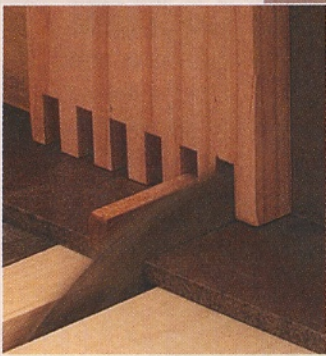

Perfect box joints every time? With this jig, now it's possible.

Accuracy. That's the key to success for just about any jig, but particularly for a box joint jig. So when we were coming up with the design for this box joint jig, we tried to eliminate as many of the variables as possible that could reduce accuracy. And we did this by trying to "build in" as much of the accuracy as possible from the start.

Take the runner system, for example. Most box joint jigs are

simply attached to a miter gauge. If there is any slop in your miter gauge bar, it can throw off the accuracy of the jig. But instead of using a miter gauge, this jig fits directly into the miter gauge slots of your table saw, see left photo below. The sides of the jig serve as runners. And since the jig travels in both slots, there isn't any chance of racking.

Some box joint jigs use an adjustable index key to space the fin-

gers of the box joints. The problem with this is that you have to fine-tune the adjustment every time you want to switch to a different size of box joint. Instead, this jig uses a system of removable fences with separate keys for different sizes of box joints. A simple stop on the end of the jig allows you to return each fence to the exact position it was in the last time you used it, see right photo.

Carriage - These removable fences all bolt on to a common base or "carriage." The carriage is the part of the jig that will ride in the miter gauge slots of your table saw. I

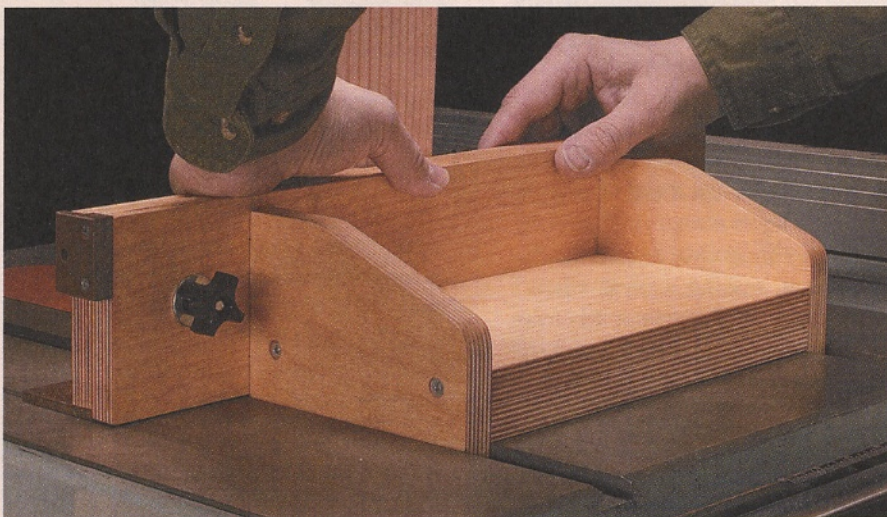

▲ **Two are Better Than One.** The sides of this jig form runners that ride in the miter gauge slots of your table saw.

Having two runners gives the jig more stability and offers less possibility for error due to racking of the jig.

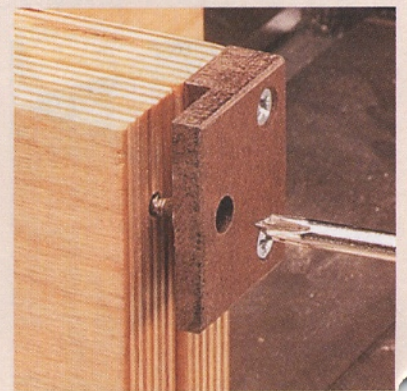

▲ **Stop.** A screw in the end of the fence contacts a hardboard stop for accurate set-up every time.

started by making this assembly.

As you can see in Figure 1, there are only three parts to the carriage of the jig — a base, a pair of sides, and a fixed fence. Making the *sides (A)* is straightforward. They are cut to size out of 3/4" Baltic birch plywood. The top edge of each side is tapered and then a couple of countersunk screwholes are drilled in each one (Figure 3).

Base – Making the base requires a little more attention to detail. You can see in Figure 2 that the *base (B)* is nothing more than two layers of plywood. But it has to be sized to fit in between the miter gauge slots of your table saw. And since this distance will vary from saw to saw, you'll have to custom fit the base.

I made my base by cutting the two layers to *width* first. Then I cut them a hair longer than the distance between my miter slots. (This allows you to sneak up on the final length.)

The two layers of the base are screwed together. Just make sure that you locate the screws close to the ends of the base, so that they won't be in the path of the saw blade.

To determine the final length of the base, I set it on my table saw and clamped the sides in place, just like you see in Figure 4. This allows you to test the fit of the jig on your table saw. You want the carriage to slide freely, but there shouldn't be any side-to-side play in the jig. It's better

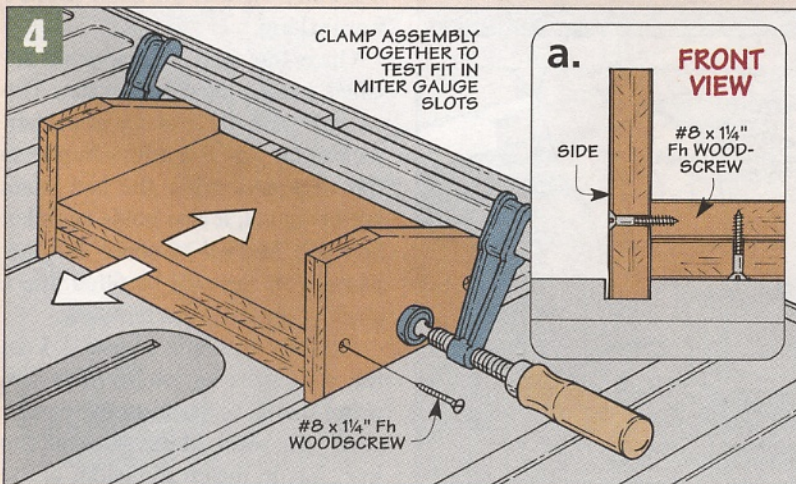
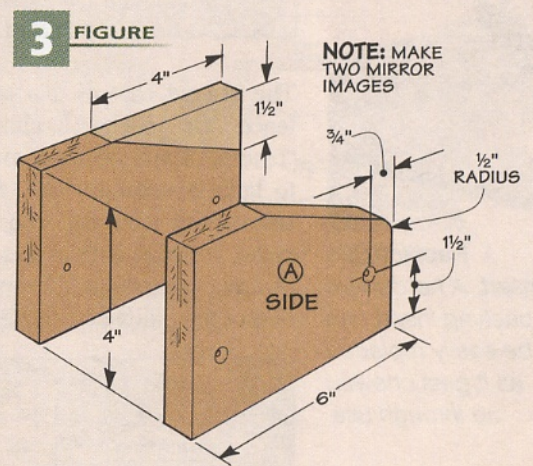
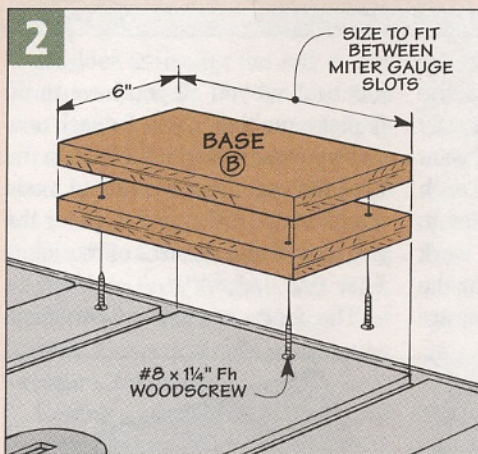
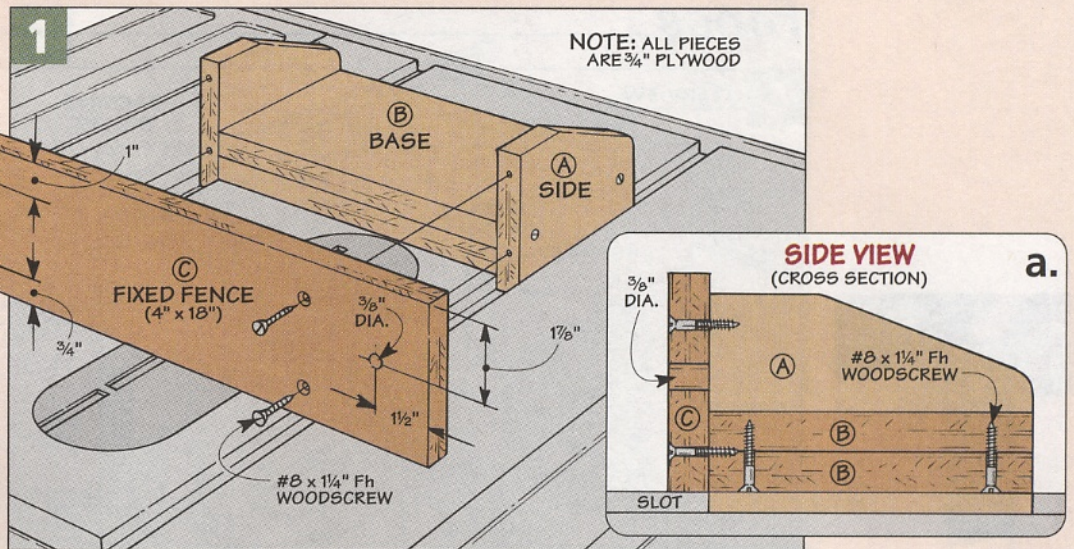

to have the fit be a little too snug than too loose, since you can always sand down the sides a little after the carriage is assembled.

My base was a little too long to begin with, so I trimmed off a hair at a time and tested the fit after each

pass. Once you are satisfied with the fit, the sides can be glued and screwed to the base. This is also done with the help of the table saw. After applying the glue, simply clamp the base in between the two sides, making sure that all the pieces are flush at the front. (The sides should be resting on the bottom of the miter gauge slots.) Then drive a few screws through the holes in the sides and into the base.

Fixed Fence – The *fixed fence (C)* provides a means of attaching the removable fences that you will be making later. If you take a look at Figure 1, you'll see that it's just a piece of 3/4" plywood. A hole is drilled at each end of the fence for the carriage bolts that will be used to attach the removable fences to the jig. The fixed fence is then screwed to the front of the carriage.

Fence

5 OVERVIEW

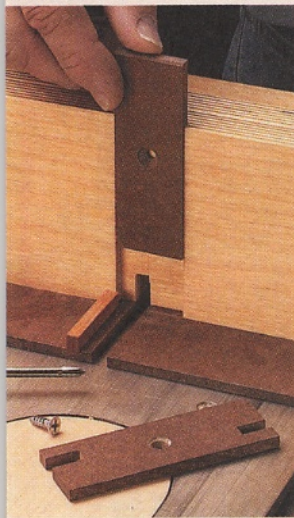
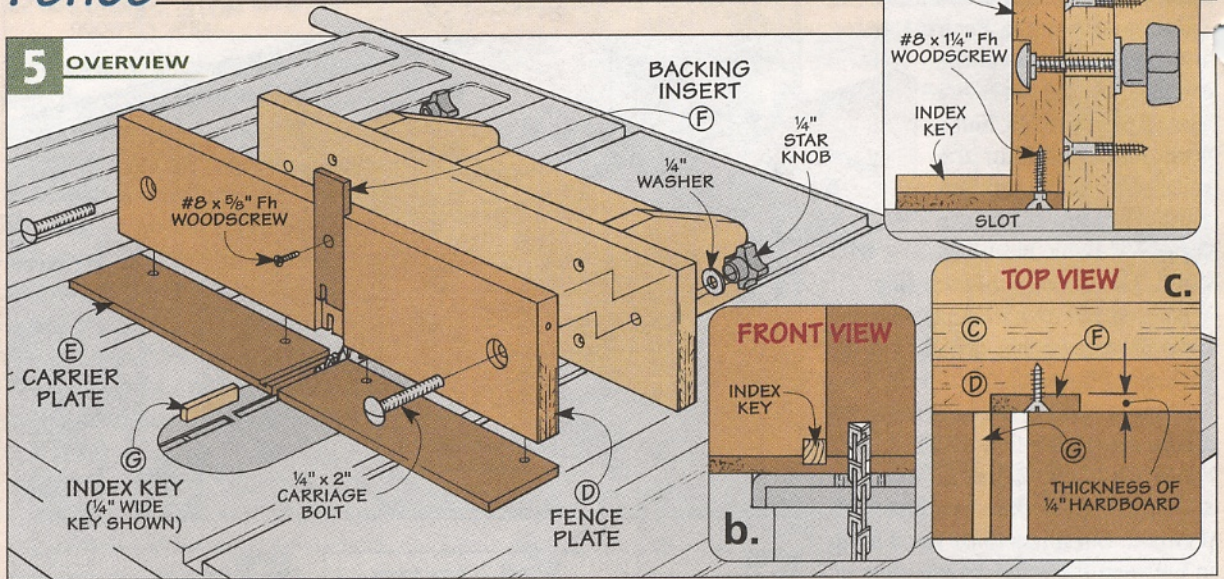

▲ **Replaceable Insert.** A hardboard backing insert can be easily replaced as it gets chewed up through use.

The second part of this jig is the fence. Or maybe I should say “fences.” That’s because you’ll want to build a separate fence for each size of box joint that you want to make. But this isn’t as much work as it may sound like. Except for the size of the index key, the fences are

identical, so you all you have to do is make multiple parts for each one.

If you take a look at the box on the opposite page, you’ll see that I made a total of five different fences for the five most common sizes of box joints I use ($1/8$ ”, $1/4$ ”, $3/8$ ”, $1/2$ ”, and $3/4$ ”).

The fence consists of two main

parts — a fence plate and a carrier plate, see Figure 5. The *fence plate* (D) starts off as nothing more than a piece of $3/4$ ” plywood, cut to size. A shallow dado is cut in the front of this piece to hold a replaceable backing insert that will be added later.

In order to position this dado, I installed a $3/4$ ” dado blade in my table saw. Then the fence plate is placed against the carriage of the jig, making sure the two are flush on the ends. With a pencil, mark the location of the dado blade on the edge of the fence plate (Figure 6).

Then with the jig removed from the table saw, cut a dado that is $1/4$ ” wider on each side of the markings (Figure 6a). By using the rip fence as a stop, I was able to cut the same-size dado on all five of the fence plates I was making.

Once the fence plates were finished, I made the carrier plates. The *carrier plate* (E) is an important part of the jig. It not only supports the workpiece while the box joints are being cut, it also holds an index key that is used to space the box joints. This key will be fitted into a shallow slot in the carrier plate.

As you can see in Figure 7, I cut the slot for the key on my table saw, using the jig to back up the carrier plate. The width of the slot (and the key) has to match the width of the

6

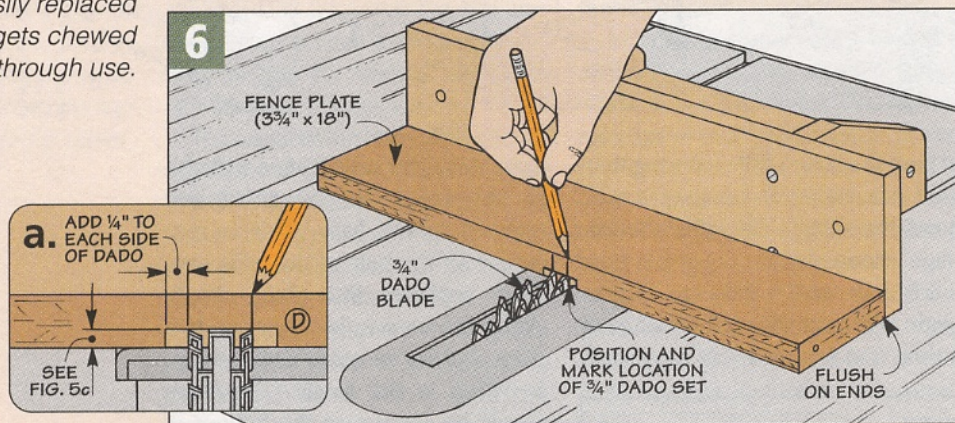

7

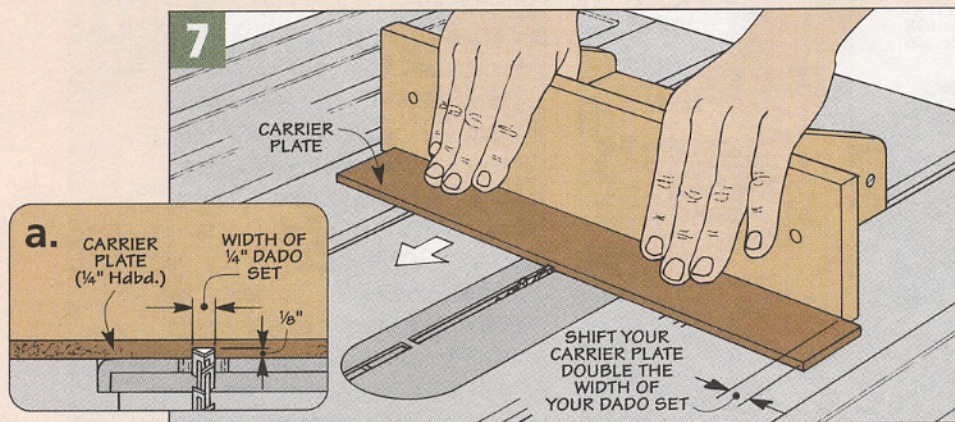

kerf cut by your saw blade or dado blade. I made the slot for the 1/8" index key with a regular (1/8" kerf) saw blade. Then I switched to a stack dado set to make the slots on the rest of the carrier plates.

In order to position each slot, all you have to do is slide the carrier plate to the left so that the end extends past the left side of the fixed fence, as shown in Figure 7. The amount of this offset should be twice the width of the slot you're cutting. In other words, 1/4" for a 1/8" slot, 1/2" for a 1/4" slot, and so on.

After cutting the slot for the key, the carrier plate is screwed to the bottom of the fence plate so the two are flush on the ends. (Again, make sure to keep the screws out of the path of the blade.)

Mounting Holes – Carriage bolts, washers, and knobs are used to attach the removable fence assembly to the carriage of the jig. But in order to do this, you need to drill a countersunk mounting hole at each end of the fence. This is done in several steps. In Figure 8, you can see how I used a brad point bit to transfer the hole locations from the carriage to the removable fence.

To drill the counterbored holes, I started by drilling a small (1/16"-

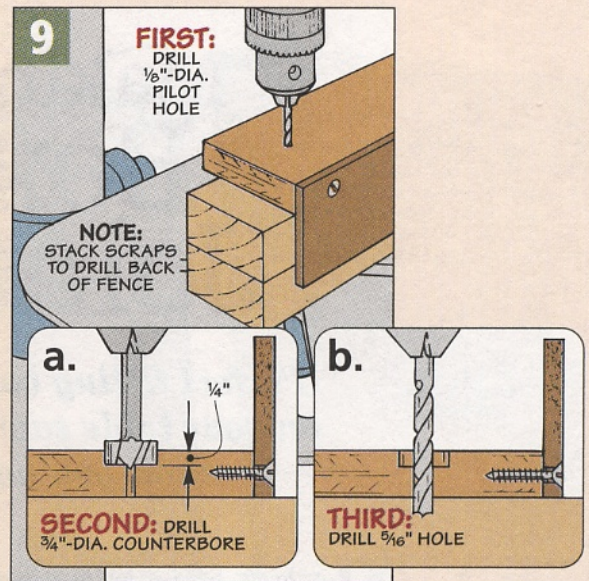
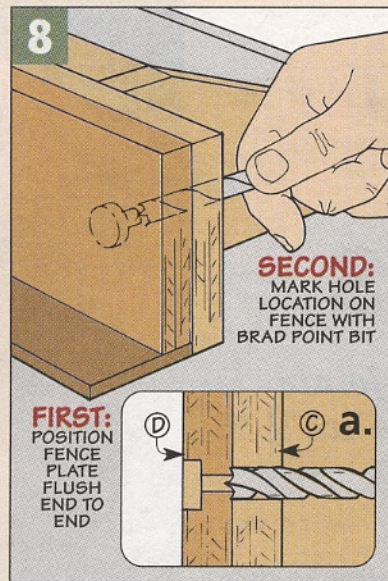

dia.) pilot hole through each end of the fence, right where I had marked the centerpoints on the back of the fence (Figure 9). Then I used a Forstner bit to make the counterbore on the front of the fence (Figure 9a). Finally, I finished by enlarging the through hole with a 1/4"-dia. bit (Figure 9b).

Backing Insert – The *backing insert* (F) is cut from 1/4" hardboard. (Make up some extras to have as replacements.) The insert is attached to the fence with a single screw through the center (Figure 10).

Index Key and Stop – Once the fence is mounted to the carriage, you can add the final touches. First, a hardwood *index key* (G) is cut to fit the slot in the carrier plate and glued in place (Figure 10). Then a *stop* (H) is made out of two small pieces of hardboard and screwed to the end of the fixed fence on the carriage, as you see in Figure 11. A screw in the end of the fence plate contacts the stop and provides a means of fine-tuning the fence setting. (For more on tuning the jig to cut box joints, see the article on page 10.)

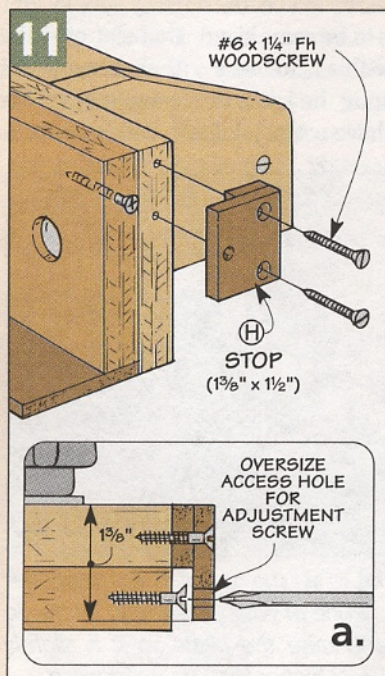
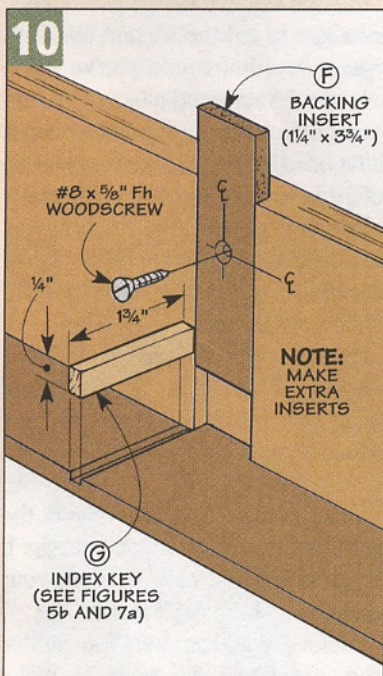

Fences

The thing that makes this jig unique is its use of removable fences. Instead of having to readjust the fence and index key when you want to make a different size of box joint, you simply bolt on a different fence for the size of joint you wish to make. With the exception of the width of the index key and the slot (see photos at right), all the fences are identical.

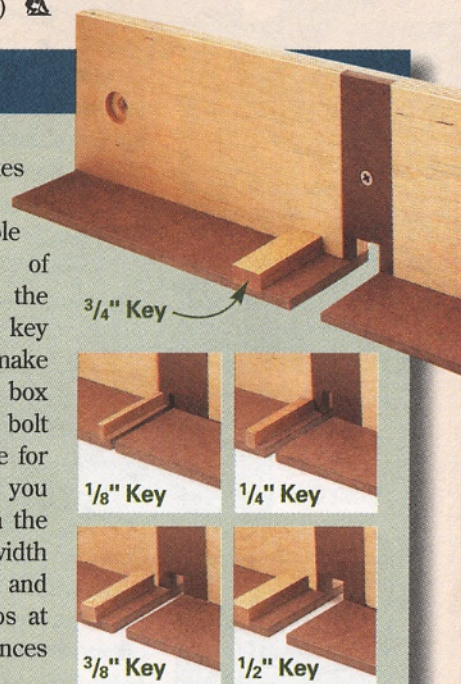

Making Box Joints

Perfect fitting box joints on your table saw — we'll show you how.

Box joints have a lot of things going for them. They're strong. They don't require a lot of special skills or equipment. And they look great. With their rows of evenly-spaced pins, box joints have a traditional, almost old-fashioned appeal, making them perfect for a project like the classic Carpenter's Toolbox on page 14.

BOX JOINT ANATOMY

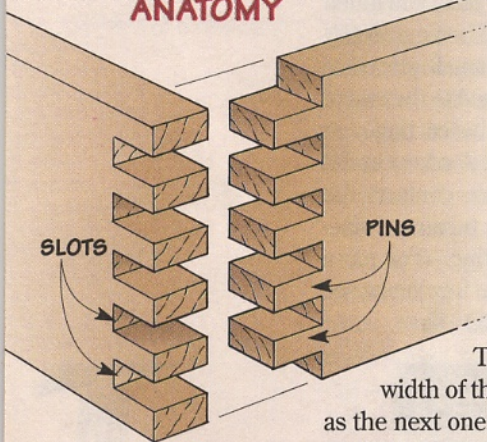

Interlocking Fingers – Box joints are made up of alternating pins and slots, see drawing at left. The pins on mating pieces interlock like tiny fingers. This creates a lot of good, face-grain glue surface and makes for a stronger joint. But for the optimum joint, you still need a snug, accurate fit between the pins and the slots.

The trick to getting a good fit with box joints is precision and consistency. The width of the pins has to match the width of the slots. And each pin has to be same size as the next one. The best way to achieve this is to use a jig. Once the jig is adjusted properly, cutting the joints is almost automatic. (If you don't already have a box joint

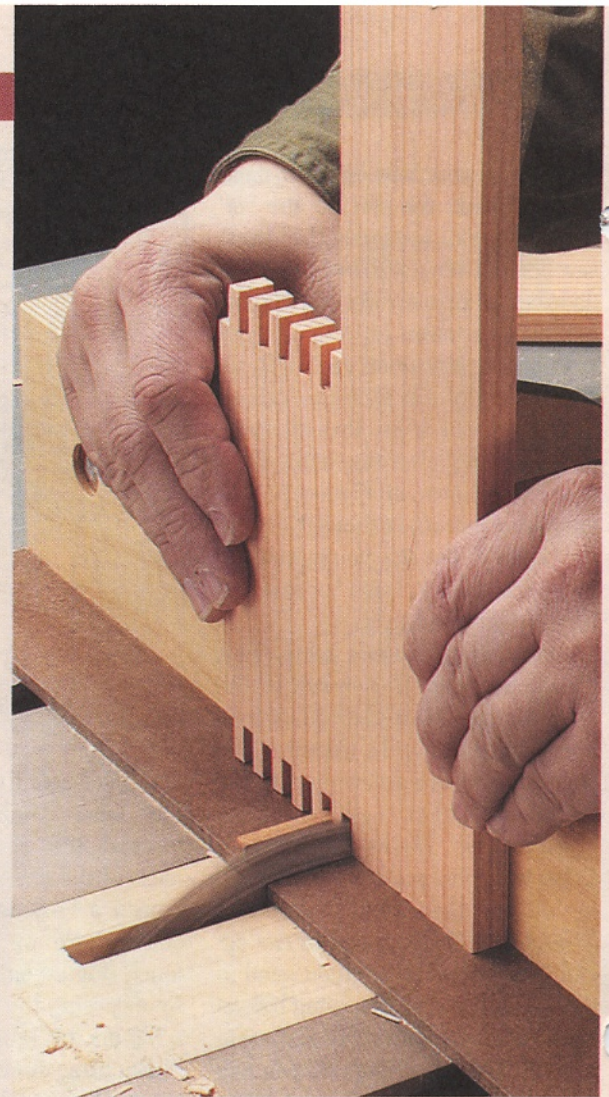

jig, you can build the one on page 6.)

Of course, adjusting the jig is where the challenge lies. Most box joint jigs use an index key to determine the size *and* spacing of the slots and pins. The process is fairly simple. You cut the first slot in the workpiece, place that slot over the index key to cut the second slot, and then keep working your way down until you've got a complete row of evenly-spaced slots and pins.

But in order to get a perfect fit, you have to spend a little bit of time adjusting the position of the index key in relationship to the blade of your saw. And the best way to do this is to cut some box joints on a couple of test pieces before moving on to your actual workpieces.

Setting Up the Jig – The first step to setting up the jig is to install your saw blade. Whether you are using a dado blade or a single saw blade (for 1/8" box joints), the width of the blade needs to match the width of the index key on your jig. If it doesn't, you'll have to shim your dado blade to make it match.

Before you can use the jig for the first time, you need to make

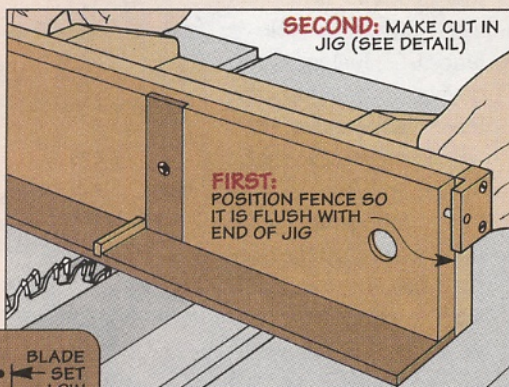

1 To position the removable fence for the initial cut through the jig, set it flush with the end of the fixed fence and lock it in place.

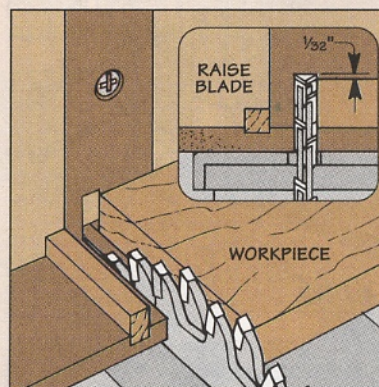

2 To set the height of the blade, set one of your workpieces on the jig and raise the blade so it is slightly (1/32") higher than the workpiece.

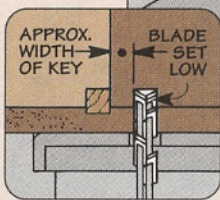

an initial cut through the carrier plate and backing insert. To position this cut, see Step 1.

To set the height of the blade, I use a piece of the same stock that I cut my workpieces from (Step 2). The blade should be slightly (about 1/32") higher than the thickness of your workpieces. This way, the pins will stand a little proud, and you can sand them down flush with the sides.

Test Pieces – Rather than diving right in and cutting the box joints on my workpieces, I like to start with a couple of test pieces. But it's important that these test pieces be the same thickness *and* width as your actual workpieces.

Why? Because if your jig is off just a hair, you probably won't notice it if you only cut one or two slots as a test. But a small error can add up to a big one over the width of the workpiece. And the only way to determine this is to make your test pieces the same width as your workpieces.

Make Test Cuts – Cut the box joints on the ends of the test pieces, as shown in Steps 3 and 4. Once you are done, try fitting the pieces together and compare the results with the drawings in the box below.

If the pieces fit together perfectly on the first attempt, great. You're ready to move on to your actual workpieces. But chances are that you will have to make an adjustment to your jig by moving the fence (or the index key). On our jig, this is just a matter of loosening the knobs on

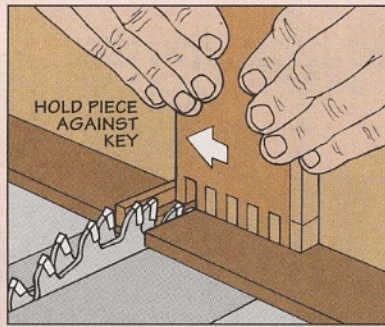

3 Set the first test piece against the key and cut a slot. To cut remaining slots, move the piece over so the slot you just cut straddles the key.

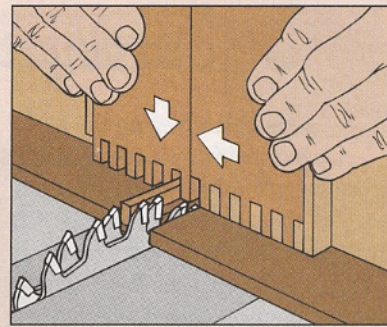

4 To cut the first slot on the second test piece, butt it up against the bottom edge of the first test piece. Then cut the rest of the slots.

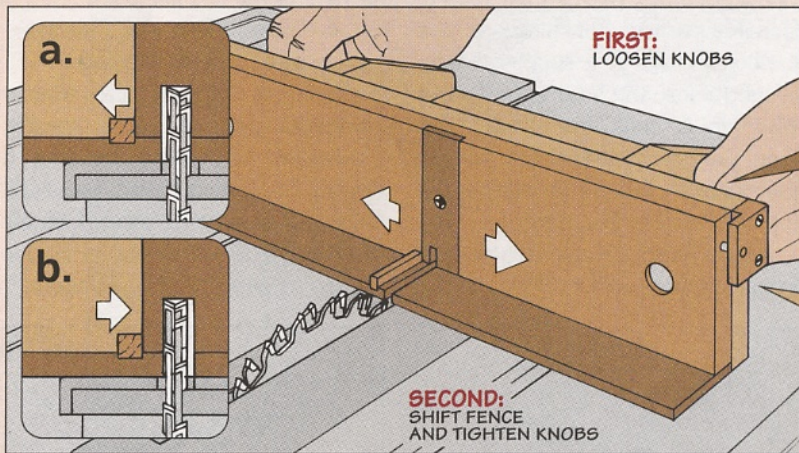

5 Check the fit of the joints (see box below). If they are too loose, shift the fence and/or index key further away from the blade (see detail

'a'). If they are too tight, shift the index key closer to the blade (see detail 'b'). Then make more test cuts to check the new setting.

the back and nudging the fence over a bit, as shown in Step 5.

The difference between a perfect-fitting joint and one that is too tight or too loose is only a few thousandths of an inch, so move the fence in very small increments. After

each adjustment, make another series of test cuts. Repeat this process as many times as necessary until you're satisfied with the fit. Then you can tighten the knobs down and adjust the screw on the end of the fence to contact the stop.

Checking the Fit

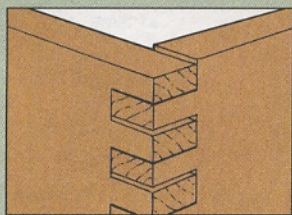

Loose fit. If there's a gap between each pin, simply slide the index key away from the blade.

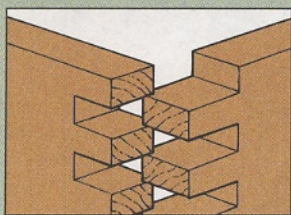

Tight fit. If the pins won't fit into the slots at all, then slide the index key towards the blade.

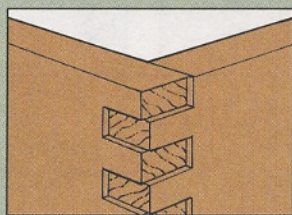

Short pins. If the dado blade is set too low, you'll end up with pins that are too short. So raise the blade slightly.



▲ With a perfect box joint, the two pieces will fit snug, and the pins will be a little proud before sanding.

Cutting the Box Joints

Although adjusting the jig for a perfect test fit is usually the most challenging and time-consuming part of the process, there are still some things to watch out for when it comes time to cut the box joints in your actual workpieces. Fortunately, there are a few simple precautions you can take to ensure success.

Visual Appeal – When building with box joints, I typically shoot for visual accuracy rather than dimensional accuracy. For instance, the toolbox on page 14 is supposed to be 8" tall (before the lid is cut off). But whether it ends up exactly this height or not, the important thing is that there's a full pin (or slot) at the top and bottom of each piece.

Extra-Wide Pieces – To do this, I typically start with workpieces that

are extra wide and then trim them down after the box joints are cut, see Step 6. This way, I always end up with a full pin (or slot).

Of course, there are times when a workpiece has to be a specific dimension, like when building a drawer. But even in these cases I still start with an oversize piece. I simply trim the pieces so the pin (or slot) is the same size at the top and bottom.

NOTE:
CUT OVERSIZE
BLANKS TO WIDTH
AFTER MAKING
BOX JOINTS

WASTE

NUMBER
CORNERS
AND CUT THEM
IN SEQUENCE

Label Pieces – Another thing I like to do is label the front, back, and side pieces and number the joints so I can cut the joints in sequence, see drawing above and Step 4 below.

Consistent Pressure – When cutting the box joints (see the steps

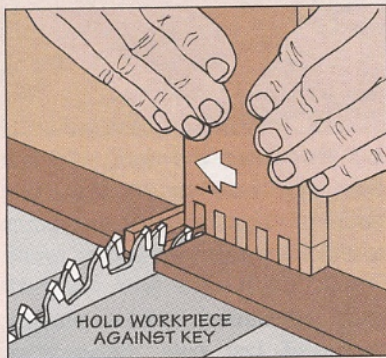

1 To begin, set the bottom of the first workpiece against the key and hold it tightly against the fence and carrier plate. Then cut the first slot.

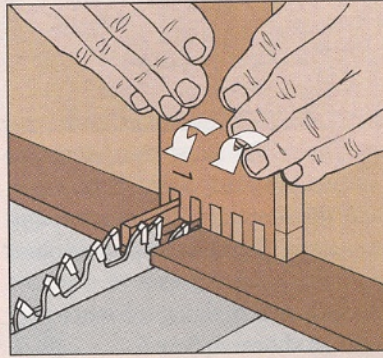

2 Now, move the piece so the first slot straddles the key and cut a second notch. Repeat this process until all the slots on this end are cut.

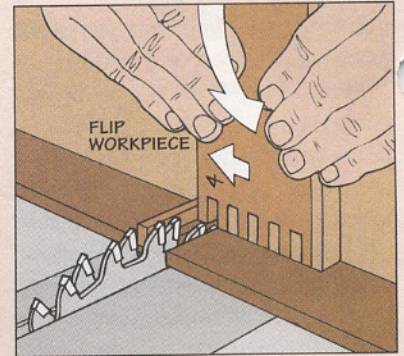

3 After all the slots are cut on one end, flip the piece end-for-end, keeping the waste edge on the same side. Then cut the slots on this side.

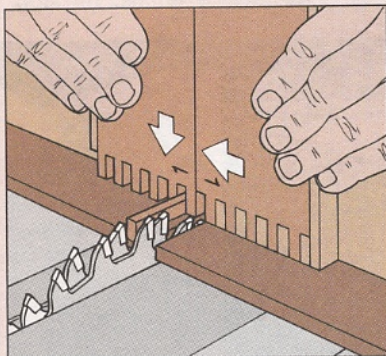

4 Now, rotate the first piece so the waste is outside and the first slot fits over the key. Butt the mating piece against the first and cut the first slot.

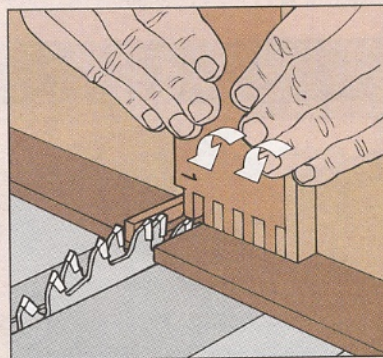

5 Now, slide the slot you just cut in the mating piece up tight to the key. Continue this procedure until the box joints are cut on all pieces.

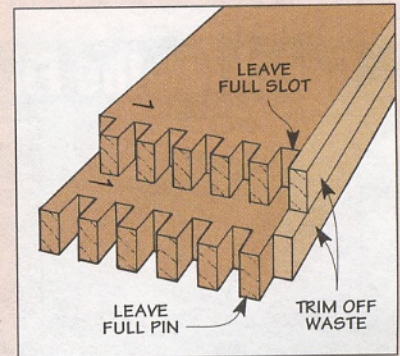

6 Before assembling the box, rip the waste edge off each piece so there's a full pin and slot on the top and bottom of the piece.

below), you still have to think about consistency. Even shifting the pressure slightly can affect the fit of the box joints. So I hold the jig with both hands and perform each pass in exactly the same manner.

Unfortunately, even if your box joints fit perfectly, you may run into another problem — chipout.

Chipout — Our jig takes care of this problem, but there are a few other things you can do to minimize it. First, make sure your blade is sharp. And don't push the pieces through the blade too quickly. If you're getting a lot of chipout, try slipping a scrap piece of hardboard behind the workpiece so that each cut is backed up completely.

Smooth Assembly — After cutting the slots on all your pieces, you're ready to assemble the box. Here's where I like to take a few precautions to keep things from getting too frantic.

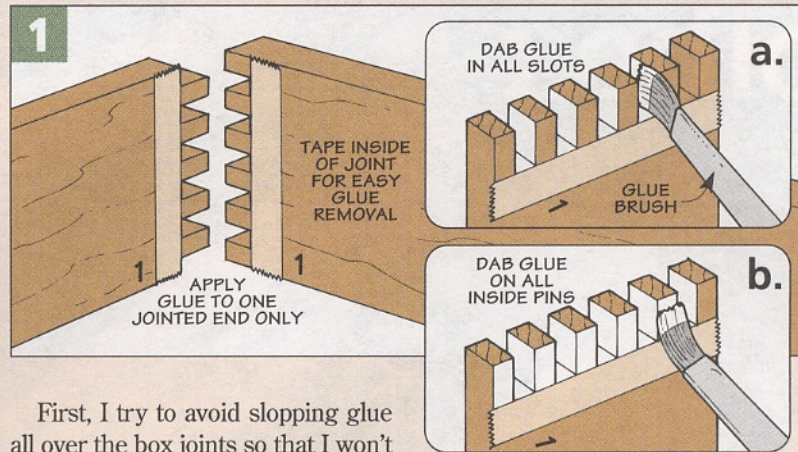

First, I try to avoid slopping glue all over the box joints so that I won't have a big mess to clean up later. To help with this, I tape the inside edges of the pieces (Figure 1). This way, any glue squeeze-out can be carefully peeled away later.

Time Savers — To buy myself more time, I use white glue instead of yellow glue. White glue sets up slower, which helps when there are a lot of box joints, like on the toolbox.

Also, to get the glue on quickly, I use a small "acid" brush (available at most hardware stores). You don't want much glue though. Even a little bit creates a strong hold.

When it comes to clamping up the box joints, there are a couple of other things to know. See the box below.

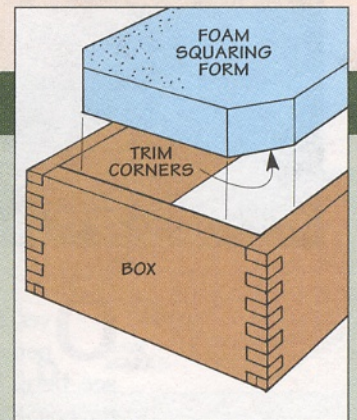

▲ **Squaring Form.** A block of wood or foam prevents the sides from bowing in.

Clamping Tips

Clamping up a project with box joints can be a little tricky. Because the ends of the box joint fingers stand proud of the sides, you can't really apply clamps directly on the corners. The answer is to use clamping blocks that will allow you to position the clamps as close to the joints as possible, see drawings below.

It's also important to make sure that you have plenty of clamps on hand. Keep in mind that each joint needs to be clamped in two directions in order to pull the pieces together. So you will need a minimum of four clamps for even the smallest project. Bar clamps work well because they allow you to concentrate

the clamping pressure in a straight line. For small projects that don't require much pressure, you can use band clamps.

To prevent the sides of larger projects from bowing under the clamping pressure, I often make a simple squaring form out of foam or a piece of particle board, see drawings at right and below.

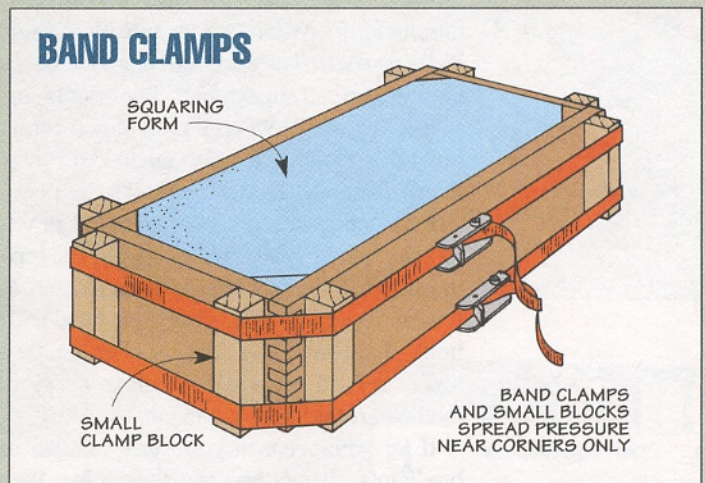
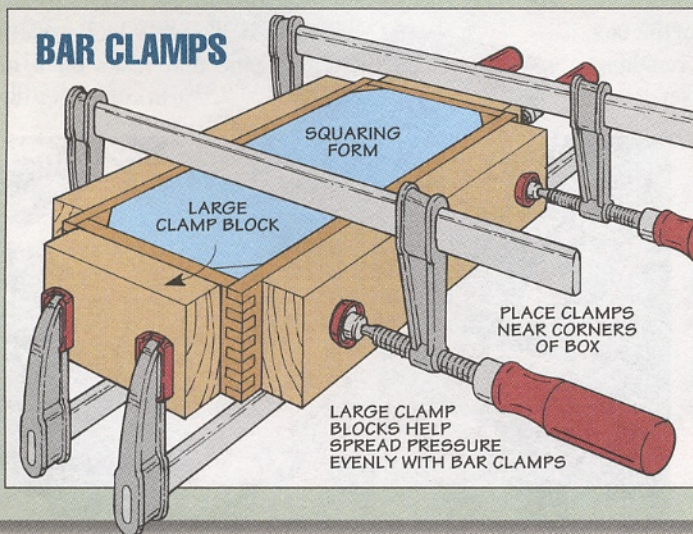

Carpenter's Toolbox

A classic-looking toolbox that's loaded with features.

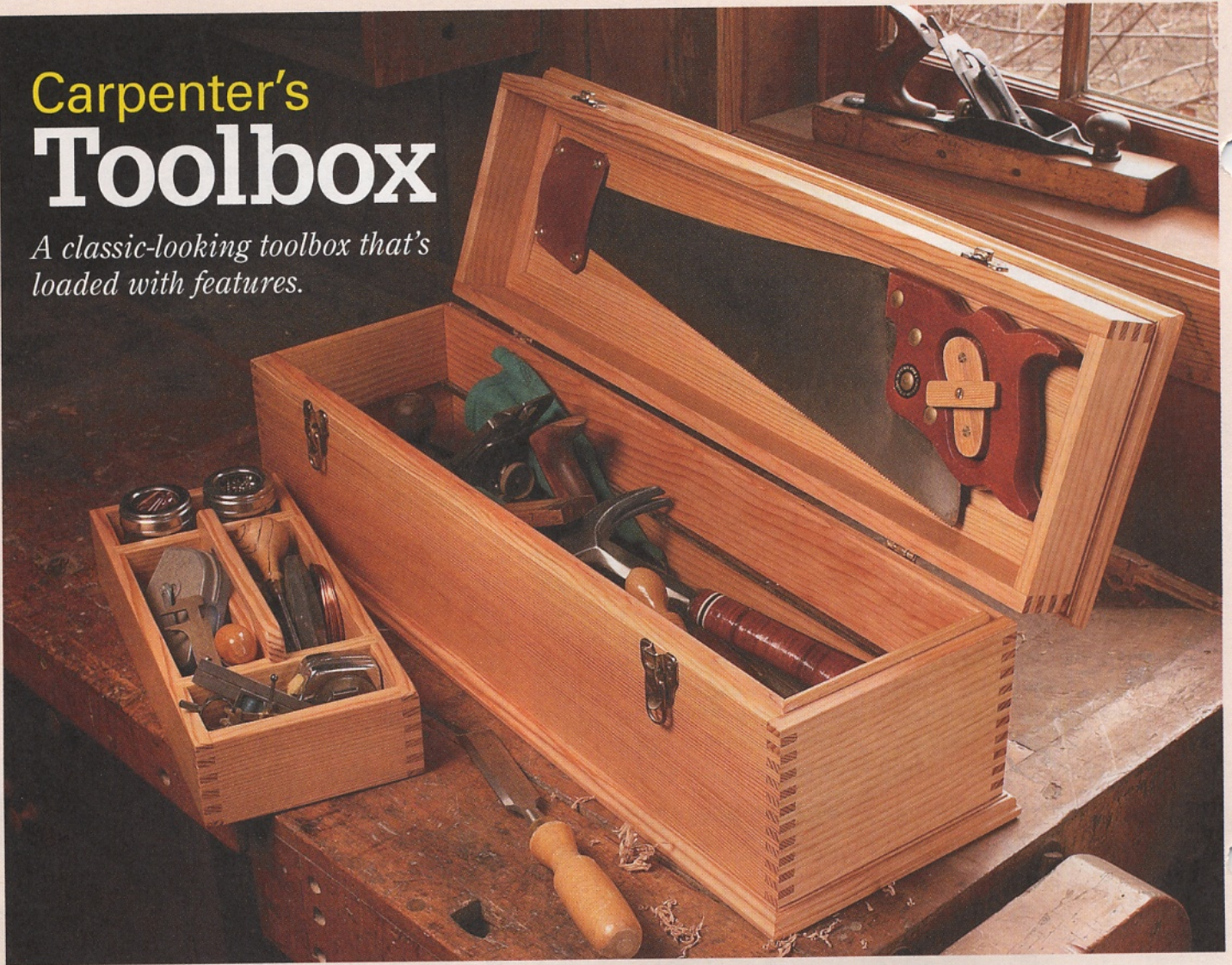

Over the years, I've run across a lot of old carpenter's toolboxes that look similar to the one you see here. But there's something different about *this* toolbox. Most of the old toolboxes I've seen were quickly slapped together with nails and butt joints. And over time, the boards had shrunk or cupped and pulled loose from the nails. You won't have that problem with this toolbox. That's because the corners are joined with interlocking box joints. The individual fingers of the box joints provide a large amount of gluing surface, resulting in a much stronger joint that holds up over time.

But the box joints aren't the only reason to build this toolbox. It's also loaded with other handy features. To start with, it's the perfect size for toting around an assortment of your favorite hand tools. A sliding tray at the top of the box has compartments for nails and fasteners. The underside of the lid is fitted with a holder for a hand saw. And a leather handle on top of the lid makes it easier to carry the toolbox around from job to job.

If for some reason you don't want to use box joints, there's an easy alternative. We've provided details on our website for building

the toolbox with rabbet joints and nails instead of box joints, see photo on opposite page. While not quite as strong as box joints, rabbets offer more strength and glue surface than butt joints. And to give the box an old-time look, we used copper nails with square heads.

Wood – A lot of the older toolboxes I've seen were made out of pine, probably because it was readily available and cheap. But I decided to go with Douglas fir instead. It's a little bit harder than pine and takes on a nice, warm color over time.



EXPLODED VIEW

OVERALL DIMENSIONS:
28³/₄"W x 8³/₄"D x 9¹/₄"H

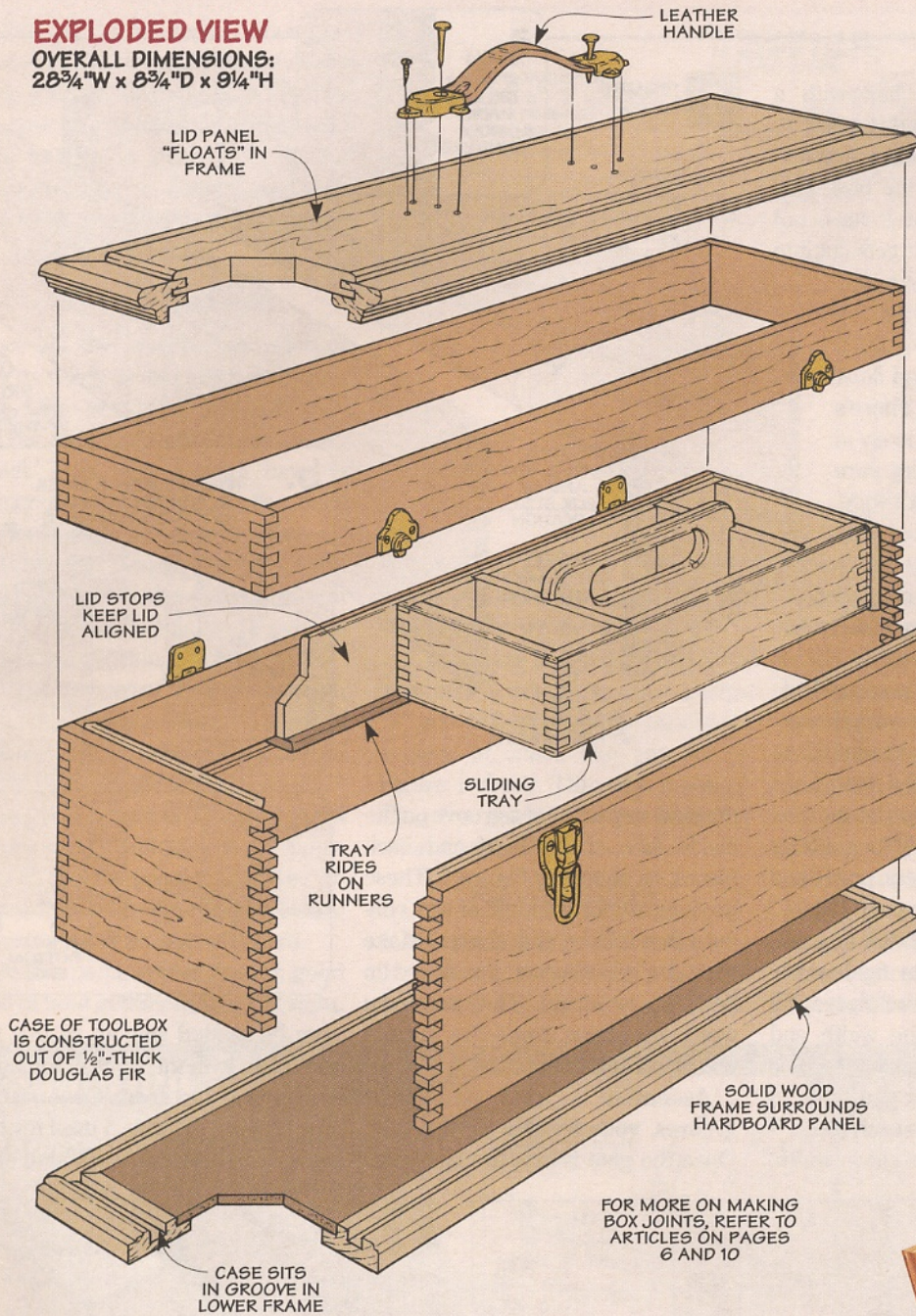

END VIEW (CROSS SECTION)

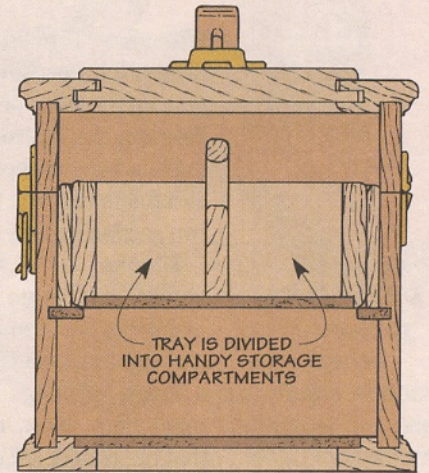

BRASS-PLATED DRAW CATCH

TOOLBOX CASE AND TRAY ARE JOINED WITH BOX JOINTS

ShopNotes To download free drawings for the rabbeted version of the toolbox, go to www.shopnotes.com.

GO ON-LINE EXTRAS

FOR MORE ON MAKING BOX JOINTS, REFER TO ARTICLES ON PAGES 6 AND 10

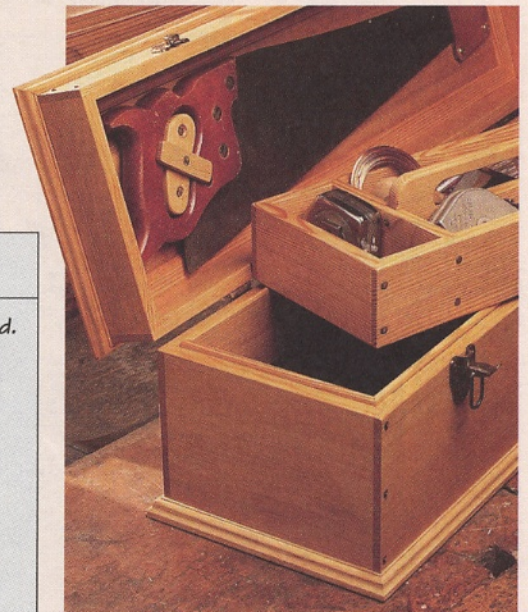

Materials & Hardware

A Front/Back (2)	1/2 x 8 1/4 (rgh.) - 28	K Tray Bottom (1)	5 7/8 x 14 1/2 - 1/4 Hdbd.
B Ends (2)	1/2 x 8 1/4 (rgh.) - 8	L Tray Dividers (2)	1/2 x 2 1/2 - 5 7/8
C Tray Runners (2)	3/4 x 27 - 1/4 Hdbd.	M Tray Handle (1)	1/2 x 3 1/2 - 8 3/4
D Lid Stop (1)	1/4 x 2 11/16 - 84 (rgh.)		
E Base Molding (1)	3/4 x 1 3/4 - 84 (rgh.)		
F Bottom Panel (1)	6 1/4 x 26 1/4 - 1/4 Hdbd.		
G Lid Molding (1)	3/4 x 1 3/4 - 96		
H Lid Panel (1)	3/4 x 6 1/8 - 26 1/8		
I Tray Front/Back (2)	1/2 x 3 (rgh.) - 15		
J Tray Ends (2)	1/2 x 3 (rgh.) - 6 3/8		

- (2) Small Brass Trunk Hinges
- (1) Leather Trunk Handle
- (2) Brass-Plated Draw Catches
- (18) #6 x 1/2" Brass Fh Woodscrews
- (6) #8 x 3/4" Brass Rh Woodscrews

Case

Whenever I build a box with a hinged lid, I usually find it easier to glue up the sides of the box first and then cut the lid from the box. This toolbox is no exception. It starts out as a four-sided box that gets cut into two sections: a case and a lid.

Blanks - I started by gluing up some 1/2"-thick blanks for the front and back (A) and the ends (B). There's a couple of things to keep in mind here. First, make sure that the blanks are extra wide. (I made my blanks about 8 1/4" wide to start with.)

Second, make up a couple of extra blanks to use as test pieces for setting up your box joint jig. These test blanks should be the same thickness and width as your workpieces.

Once you have the blanks cut to length, you can cut the box joints (Figure 1c). The fingers of the box joints are 1/4" wide by 1/2" long. (Refer to the box joint jig article on page 6 and the technique article on page 12.)

After cutting all the box joints, you can trim the pieces to final width. The exact width of these pieces will vary depending on the width and spacing of your box joints. The important thing is that you have 16 pins and 16 notches on each piece.

Once the pieces are cut to width,

1 FIGURE

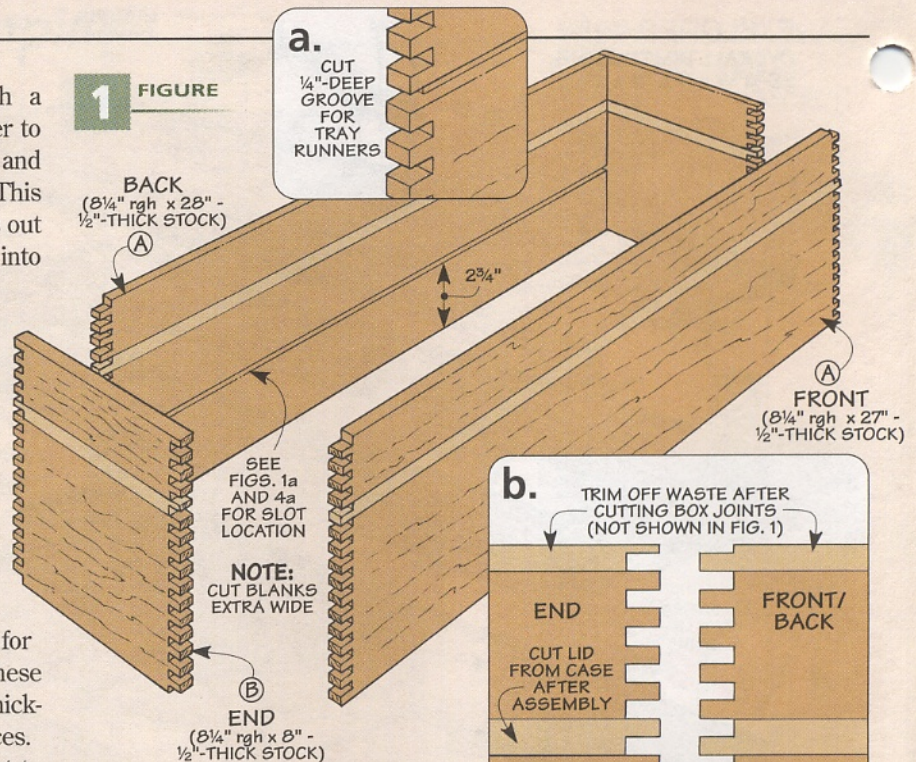

the next step is to cut a groove on the inside face of the front and back pieces, as shown in Figure 1. These grooves are for a couple of tray runners that will be added later. Make sure the grooves are positioned in between two pins. This way, you won't see them from the outside once the case is assembled.

Assembly - After cutting the grooves, you can glue up the case. Once the glue is dry, the box joints

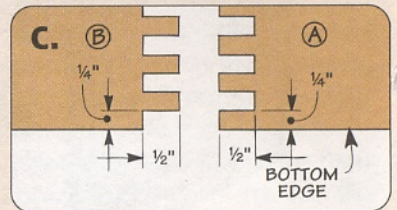
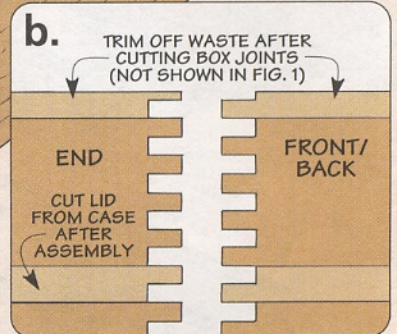

can be sanded smooth so that they are flush with the sides of the box.

Cutting Lid from Case - To cut the lid from the case, I used my table saw to cut through each side of the

2

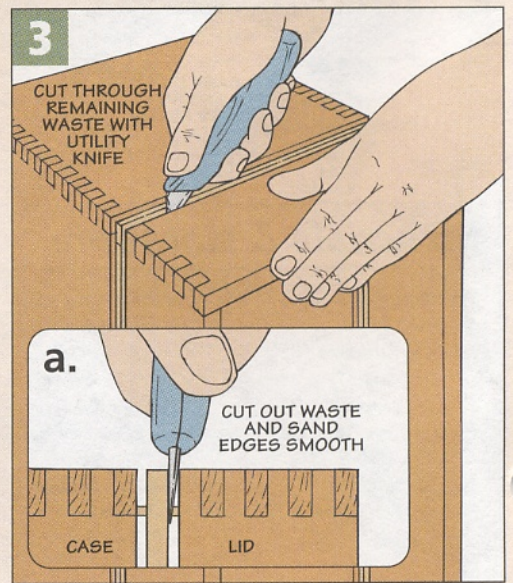
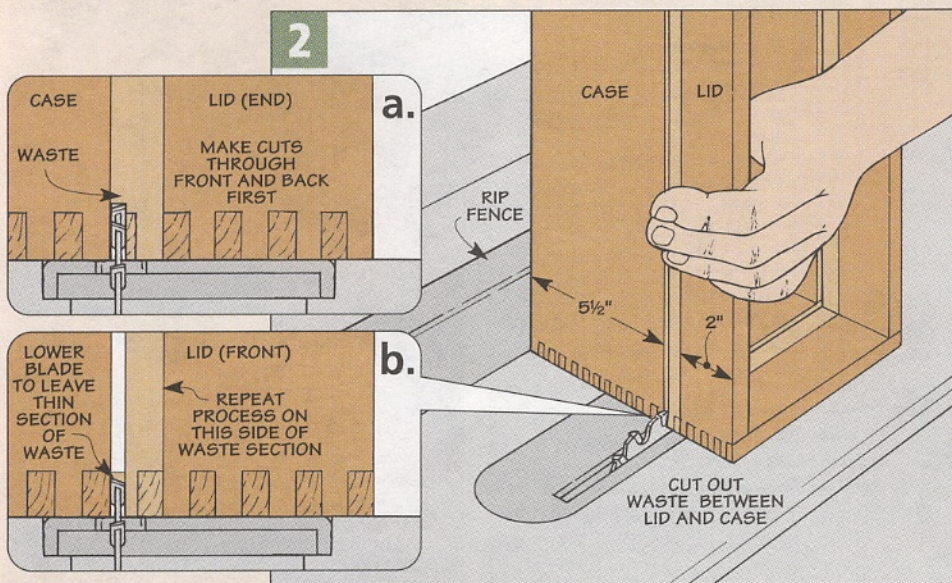

box. But if I simply cut the lid off with a single cut on each side, the box joints on the lid wouldn't match up with the box joints on the case.

The trick is to cut out a narrow section of the box *between* the case and lid – a section equal to the height of a full pin and a full notch. To do this, I first set my rip fence to make a cut through the front and back of the box, about 5 1/2" from the bottom, see Figure 2a. Then, I lowered my saw blade so it was about 1/32" lower than the thickness of my stock and made a scoring cut on each end, shown in Figures 2 and 2b.

After this was done, I moved the rip fence over for a second set of cuts using the same technique. Then a utility knife can be used to cut through the remaining material on the ends of the box that connects the lid to the case (Figure 3).

Tray Runners – With the lid set aside for the time being, you can finish up the work on the case. To start with, a couple of 1/4" hardboard *tray runners* (C) are glued into the grooves in the front and back, as shown in Figure 4.

Lid Stops – Next, you'll need to make up some *lid stop* (D) for the inside of the box. These create a lip around the inside of the box opening, aligning the lid when it is closed. These stops are cut from 1/4"-thick stock that has been rounded

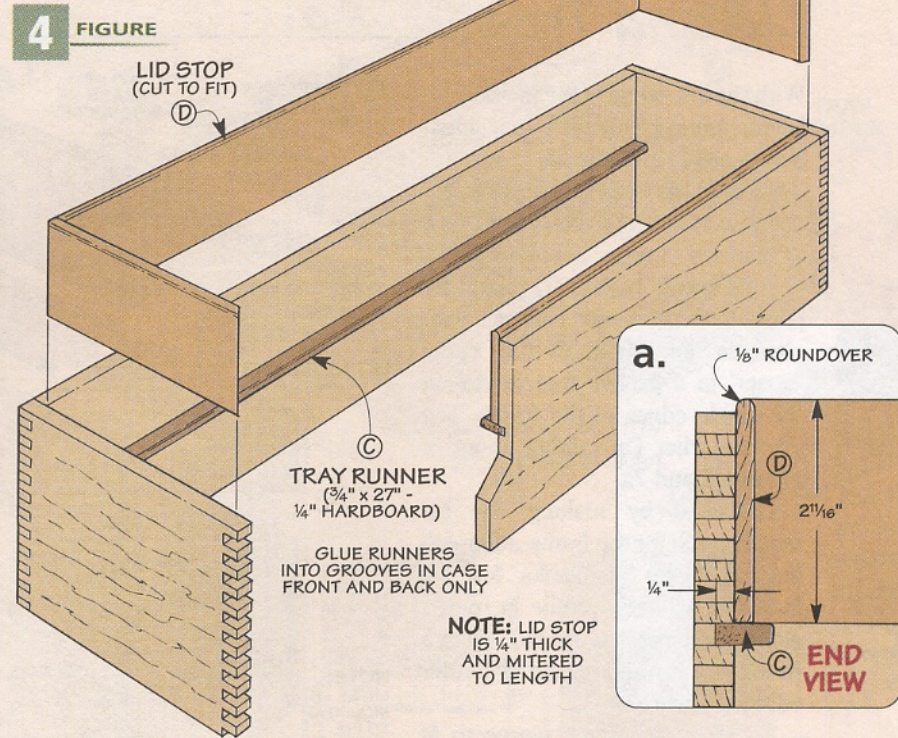

over on two edges. They are mitered to length and glued in place around the inside of the box.

Base – The base of the tool box is a little unusual. It's really a frame made up of four pieces of molding. The case fits into a groove cut in this molding. And a hardboard panel completes the base of the toolbox.

To make this base, start by creating the *base molding* (E). This is a three-step process. After cutting the blanks to size, rout an ogee along one edge, as you see in Figures 6

and 6a. Then cut a groove to match the thickness of the walls of the case, as shown in Figure 6b. Finally, cut a rabbet to hold a hardboard bottom (Figure 6c). Once this is done, the molding pieces are mitered to fit around the bottom of the case. Then the frame can be glued together around the case.

After the glue on the frame has dried, you can cut a piece of 1/4" hardboard for the *bottom panel* (F). This is simply glued into the opening in the base molding frame.

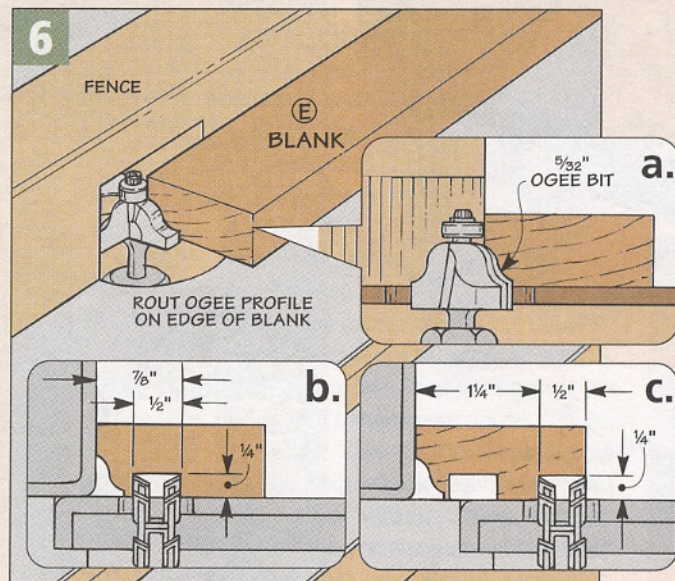
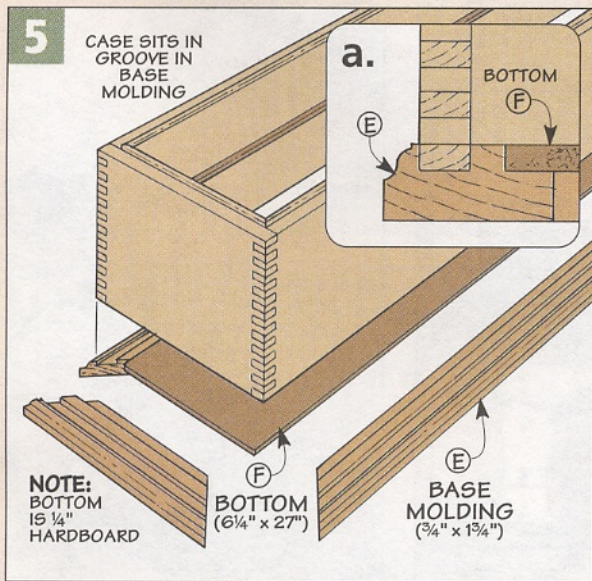

Lid and Tray

With the lower half of the toolbox finished, you can now turn your attention to completing the lid.

The lid is built much like the bottom of the toolbox. It features a mitered frame surrounding a solid wood panel. To allow the panel to expand and contract with changes in humidity, the panel "floats" in a groove that is cut on the inside edges of the frame. You can see what I'm talking about in Figures 7 and 7a.

I started by making the lid molding (G) for the frame. After cutting a couple of blanks for the panel, an ogee profile is routed along one edge (Figure 8a). Then a roundover is routed along two other edges (Figure 8b).

To allow the frame pieces to fit over the lid section of the box, a 1/2"-wide groove is cut on the face of each blank. To do this, I switched over to the table saw and used a dado blade, as you can see in Fig. 8c. Then a 1/4"-wide groove is cut on the edge of each blank to hold the lid panel (Figure 8d).

Once all the profiles and grooves have been cut, you can start mitering the individual frame pieces to fit over

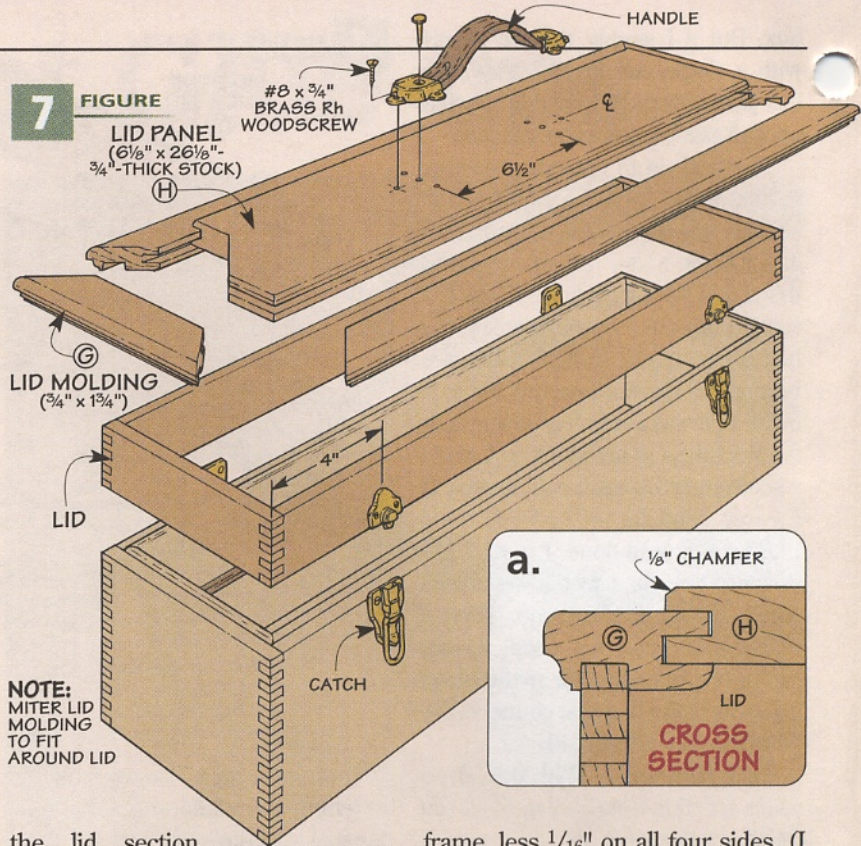

the lid section that you set aside earlier. Just cut the miters so that the frame pieces fit around the case, but don't glue the frame together just yet. You still need to make the panel.

Panel - The lid panel (H) is glued up from solid, 3/4"-thick stock. It's sized to fit in the grooves of the

frame, less 1/16" on all four sides. (I made my panel 6 1/8" x 26 1/8".)

After cutting the panel to size, you'll need to cut a groove along each edge to create a tongue that fits in the groove of the frame pieces, as you can see in Figures 7a and 9a.

Before assembling the lid frame and panel, a chamfer is routed along



▲ Lid. The lid of the toolbox features a solid-wood panel that "floats" in a mitered frame.



▲ Saw Storage. Mounted to the inside of the lid, a custom-fitted wood block and turn-button secures the saw handle. And a leather "pocket" holds the end of the saw blade.

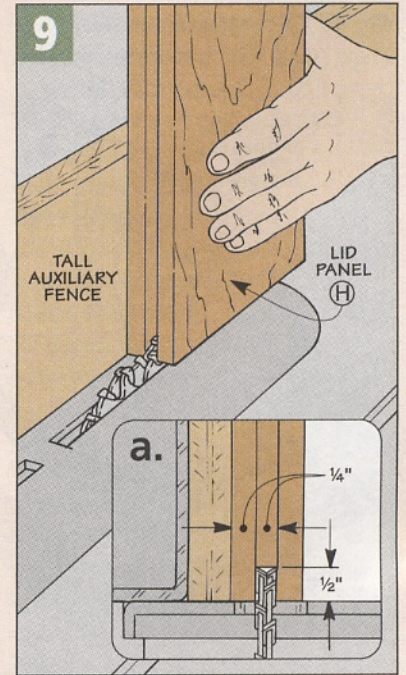
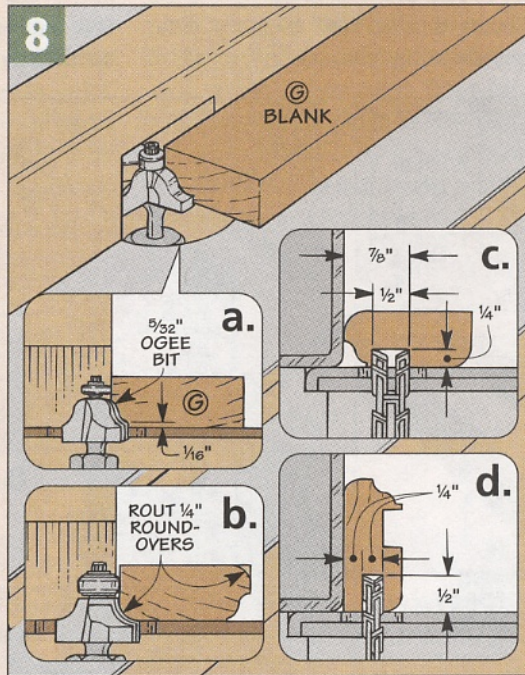

the top edges of the panel. Then the frame and panel can be glued up around the lid. Note: I used just a drop of glue on each end of the panel when gluing it to the frame. This holds the frame in place while still allowing for wood movement.

Hardware - To complete the toolbox, all that's left is to add the hinges, catches, and handle. Before attaching these items, however, I "aged" the hardware by placing it in a special darkening solution (see page 35 for more information).

If you want to store a hand saw in the lid, you can add a convenient holder and leather "pocket" to the underside of the lid. See the photos in the margin on opposite page.

Tray - Now that the toolbox is complete, you can build the tray that fits inside it. Like the toolbox, the tray is also joined with box joints. Start by cutting out blanks for the *tray front/back* (I) and the *tray ends* (J). These pieces should be cut a little wide so they can be trimmed to size after the box joints are cut (Figure 10).

After cutting the box joints on the tray pieces, a couple of dados are cut on the inside face of the front and back to hold a pair of dividers, as shown in Figure 10. Then a rabbet is cut along the

10 FIGURE

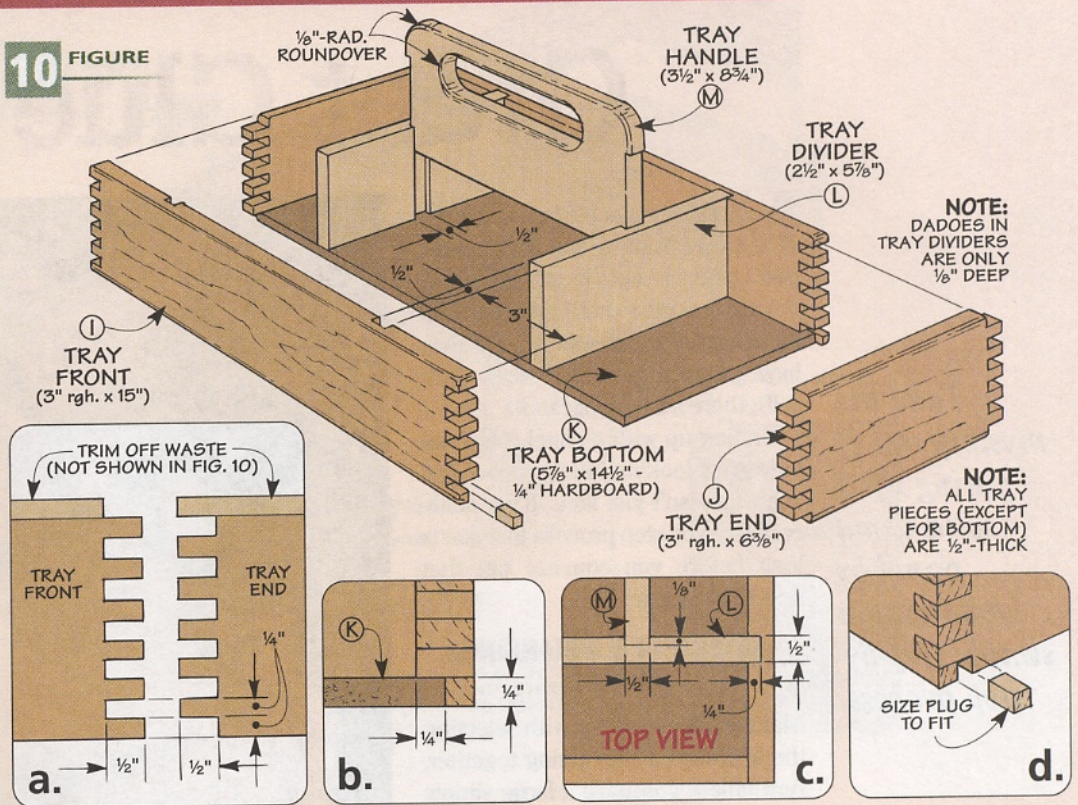

bottom edges of all four tray pieces for a bottom (Figure 10b).

Bottom - After you've glued up the four sides of the tray, you can cut a piece of hardboard to serve as the *tray bottom* (K). This is cut to fit in the opening in the bottom of the tray and simply glued in place.

With the bottom attached, you

can cut a pair of *tray dividers* (L) and a *tray handle* (M), which you can see in Figure 10. A dado is cut in each tray divider to hold the tray handle. Then a notch is cut on each end of the handle to allow it to fit into the dados in the dividers (Figure 11).

To make the opening in the handle, a couple of holes are drilled as shown in Figure 12 and the waste in between them is cut out with a jig saw or scroll saw. Then the upper corners of the handle are radiused and sanded smooth (Figure 12a). When this is done, the inside of the handle opening and the top edges of the handle are rounded over on a router table, refer to Figure 10. Then the dividers and handle are glued into the tray.

To complete the tray, some small wood plugs are glued into the ends of the tray to conceal the rabbet for the tray bottom (Figure 10d). Finally, all the outside edges of the tray are rounded over.

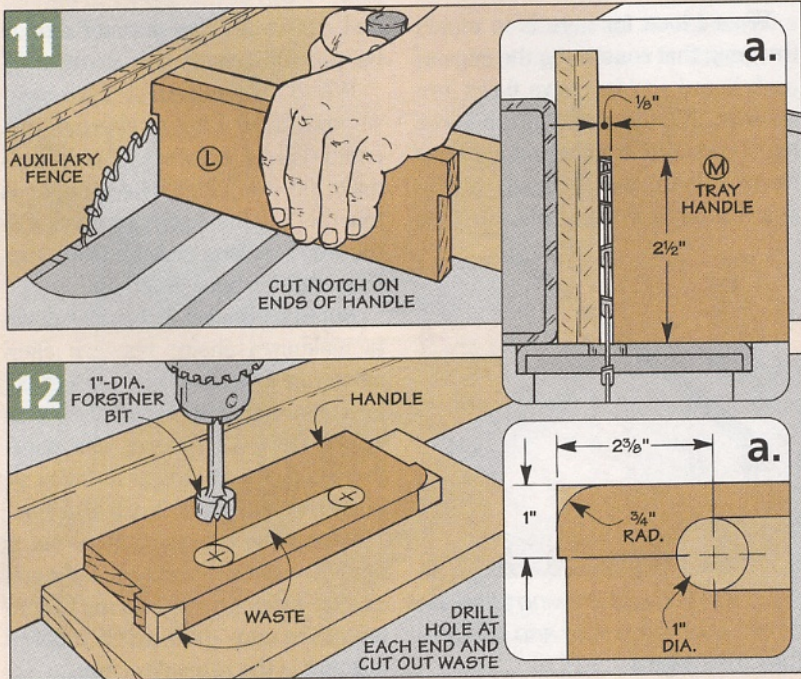
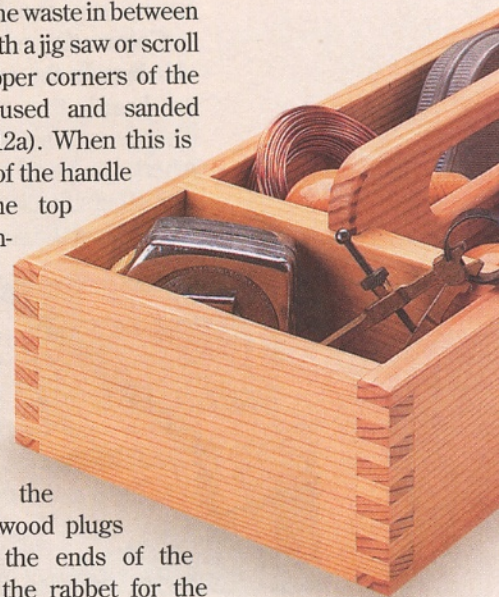

Great Glue-ups

Take the mystery out of gluing up a solid wood panel by following a simple step-by-step process.

Making a glued-up panel seems like such a simple process. Just take a bunch of narrower boards and glue them together into the size you need. But as you may have guessed (or experienced yourself), there's a lot more to it.

Ending up with a panel that's not only great-looking but starts out and stays flat, isn't just luck. It's a deliberate step-by-step process that starts long before you squeeze out that first bead of glue.

SELECTING & ARRANGING BOARDS

Making a panel starts with selecting the boards you'll be gluing together. And unless you have a large supply of lumber in your shop, selecting the boards starts with a trip to the store.

Selection – When sorting through the lumber pile, it's a good idea to go through a mental checklist as you look at each board. First, make sure the boards don't exhibit any warp (like cup, twist, or bow). There's no point in starting out with problems that might show up later in your panel.

Color – Once I have a pile of suitable boards, the next thing I look for are boards that are close in color. There's nothing worse than a panel where one board stands out from all the others because it's lighter or darker than the rest.

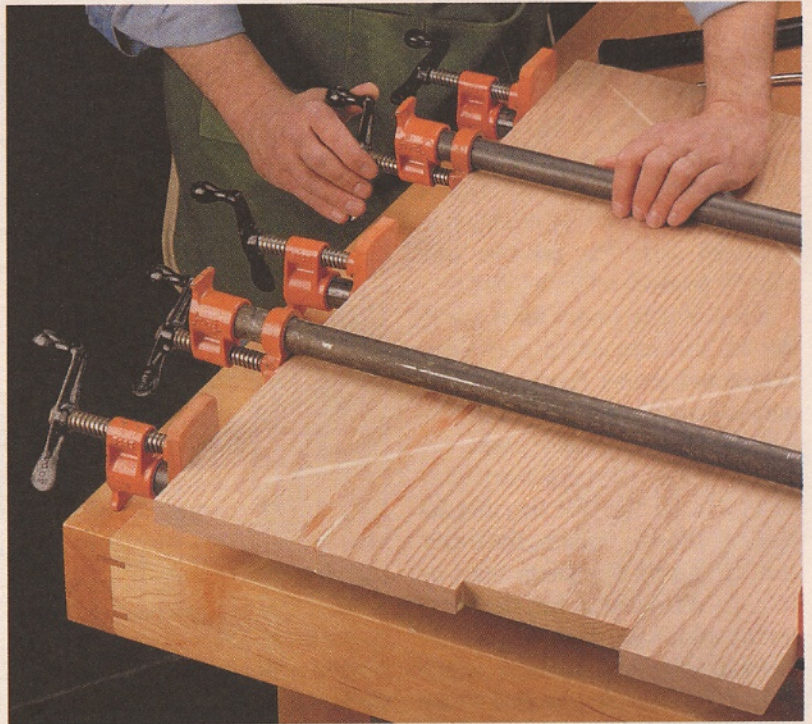

Grain – Now that the boards are matched, you'll want to take some time to study the surface grain of each board. This way, you can visualize the overall grain pattern the panel will have once the boards are glued together.

What I look for here is to match the grain that runs along the edge of each board so one curve flows into another, like the photo at the lower left shows. Or straight-grained lines on one board match those on the board next to it (right photo). This

way, the boards will "melt" together to form a panel that looks like a single, wide board.

The one thing you don't want to do is rush this process. Spend some time turning the individual boards over. I even like to flip them end for end. This way, I'll be sure to "see" all the possibilities.

Wood Movement – Like most woodworkers, I try to alternate the end grain of adjacent boards as I make up the panel. The thought is that this will minimize any chance of the wood moving and the panel cupping after it's been glued up.

But to be honest, if it comes down to making a choice between alternating the boards or not, I select the best color and grain match first. This way, I know I'll end up with panel that's looks good. And as for flatness, I haven't noticed much of a problem.

What's more important to me is how the *edge grain* matches. As you can see in Figure 1a, I do my best to orient the edge grain so each board is going in the same direction.

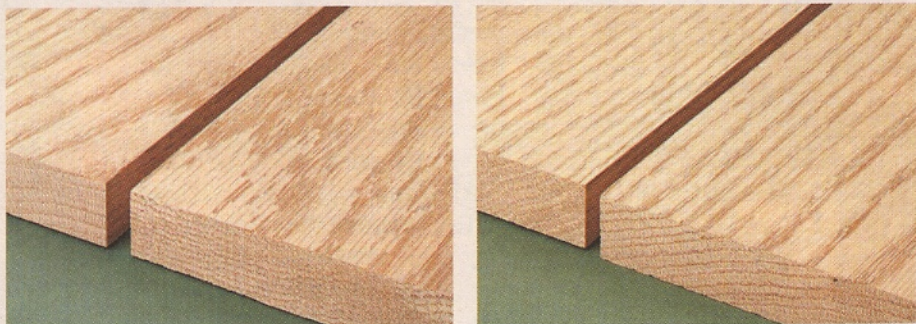

▲ **Appearance.** To get a good-looking, wide panel, it's best to avoid drawing attention to a joint line. To do this, arrange boards so curved patterns merge (left) and straight-grained boards are positioned to create an "invisible" joint (right).

The reason is simple. When you glue up a panel, you'll probably have to do a little smoothing. And whether you use a hand plane or planer to do this, having the grain going in the same direction on all the boards will minimize any tendency for chipout on the face of the panel.

CUT TO ROUGH SIZE

Once all the boards are selected you're ready to cut them to rough size. I like to cut the boards 2" to 3" longer than the final length of my panel. This way, I don't have to worry about keeping all the ends perfectly flush as I glue them up.

With the boards cut to length, you're ready to size them to rough width. As you do this, you'll need to keep a couple things in mind.

First, you want to leave enough extra material to prepare the edges of each board. And second, the *overall* width of the panel should be about 1" wider than required. This way, you'll have a little "cushion" when it comes time to trim the panel to final size. To account for both these things, I leave an extra 3/8" or so on each board.

At this point, you've spent a good deal of time getting things just right.

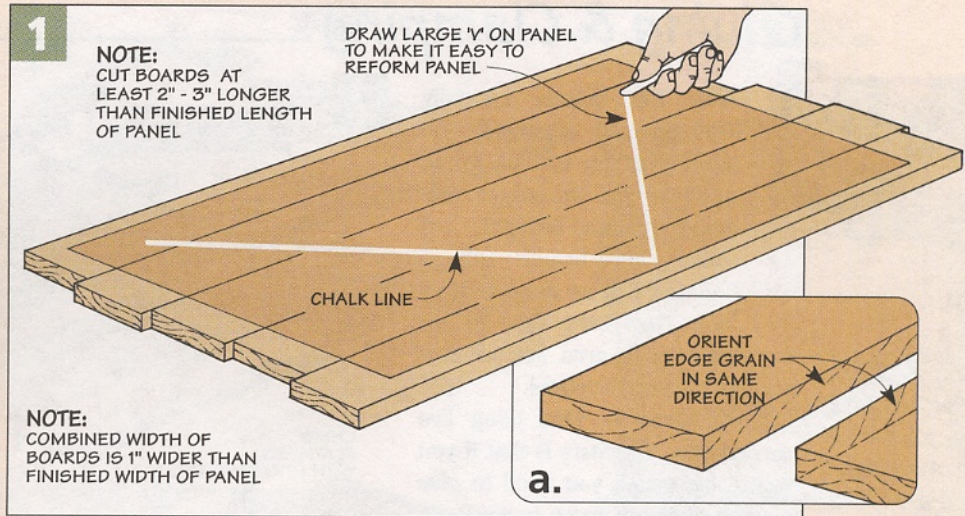

You sure don't want to throw out all that hard work by gluing up the boards in the wrong order.

A good way to avoid this problem is to take a minute to draw a large "V" across the face of the panel with a piece of chalk, like you see in Figure 1 above. This way, reassembling the panel is just a matter of reforming the "V."

PREPARE EDGES

At this point, you're almost ready to think about gluing up the panel. But first, you'll need to be sure that the

boards will form a strong glue joint. For that, the edges of each board need to be smooth and straight. But to ensure the panel is *flat*, each edge need to be *square* to the face. To prepare these edges, you can use either a jointer *or* a table saw, as you can see in the box below.

Regardless of the method you choose, it's important to set the machine up correctly. When using a jointer, I make sure the *fence* is exactly 90° to the table. And when I'm using a table saw, I double check that the *blade* is 90° to the table.

Squaring Edges

A big step towards making a flat panel is ensuring the edges of each workpiece are square to the face.

Jointer - My first choice for doing this is to use a jointer (Figure 1). A jointer takes a uniform amount off each workpiece. I slowly feed the workpiece *with the grain* (Figure 1a). After a few light passes, the workpiece has a smooth edge that's ready to be glued.

Table Saw - Another method for jointing edges is to use a table saw and a good combination blade. To do this, I use a double-cut method. Start by ripping the boards straight (Figure 2). Then repeat the cut, but only remove about half the thickness of the saw blade (Figure 2a). This second cut results in a very smooth surface.

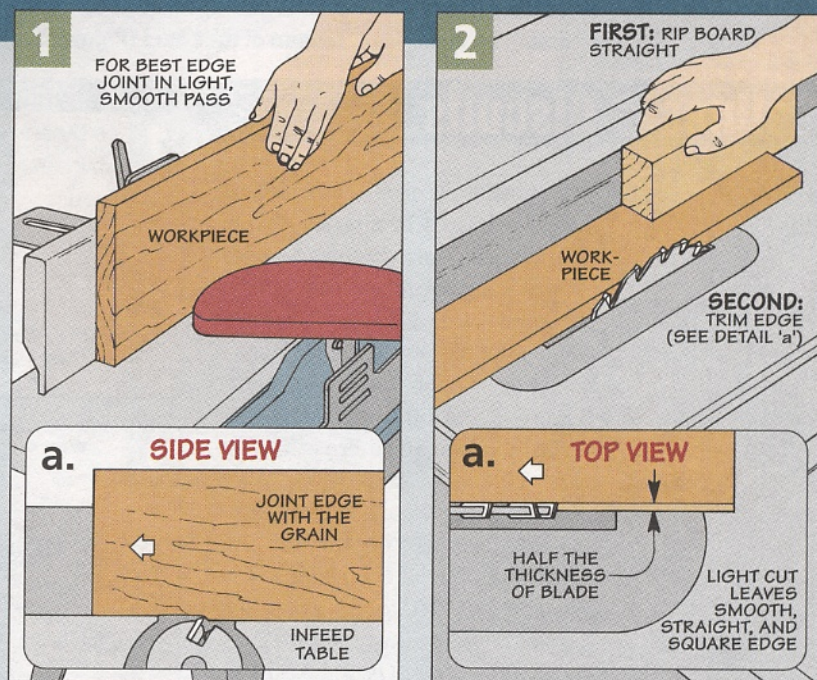

Gluing & Clamping

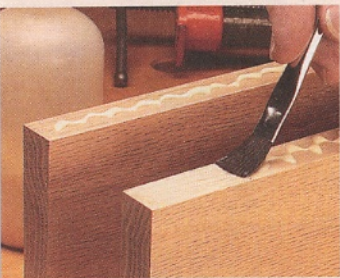

▲ **Gluing.** A bristle brush is a quick and easy way to spread a smooth, even layer of glue along the edge of a board.



▲ **Clamping.** A thin bead of glue indicates good pressure along the joint line.

With the boards carefully selected and arranged, the panel is going to look great. And with all the edges prepared smooth, straight, and square, the boards will fit together just as good as they look. Now's the time to get your work area and clamps ready to glue up the panel.

Work Area – One thing I've learned over the years is that if you want a flat panel, you need to give yourself plenty of room to work. So take the time to clear off your workbench (or even the shop floor).

Clamps – When gluing up a panel, I've always used pipe clamps. But other types of clamps will work just as well.

Regardless of the type of clamps you use, the key is to have the right number on hand. You'll need enough to space them evenly across the panel about 6" to 8" apart.

DRY RUN

With everything at hand, you might be ready to grab the glue bottle and go to work. But instead of pressing ahead at full speed, it's a good idea to make a "dry run" first.

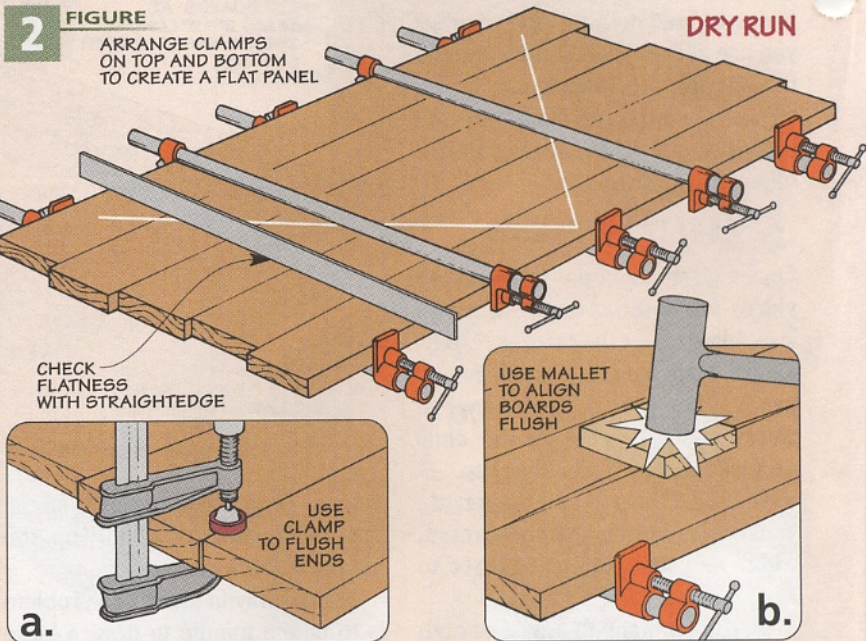

A dry run is a simple process of clamping up the panel — without the glue. This gives you a chance to pinpoint any problems and resolve them — before it's too late.

Start by laying out a few pipe clamps on your worksurface and setting the boards in place. To help distribute the pressure more evenly and prevent the panel from cupping, I like to alternate the clamps on the top and bottom of the panel (Figure 2).

Tighten Clamps – Now you can tighten the clamps just enough so any gaps between the boards disappear. This shouldn't take a lot of pressure. Just a little extra turn on the clamp once it's snug should be enough.

Now's the time to give the panel a good going over. For me that means getting down and sighting along the top surface (a straight-edge often helps here). What you're looking for is to see whether

Splines & Biscuits

Occasionally I'll need a little help to keep the boards in a panel aligned. That's when I turn to splines or biscuits to keep the outside surfaces of the boards as flush as possible.

To cut a slot for a spline, I use a hand-held router and a slot cutter (Figures 1 and 1a). But if I only need a little help here and there with alignment, I'll use a biscuit joiner to cut slots for some biscuits (Figure 2).

Regardless of the method you use, if the ends of the panel will be exposed, be sure to start and stop the slot for the spline or biscuit 2" - 3" short of the ends of each board.

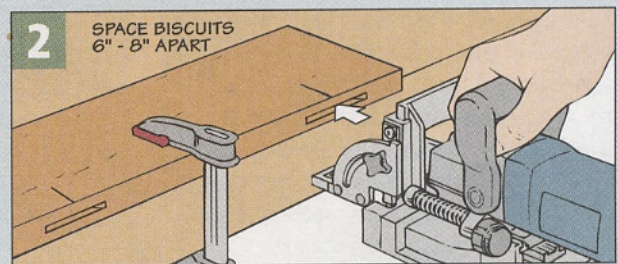
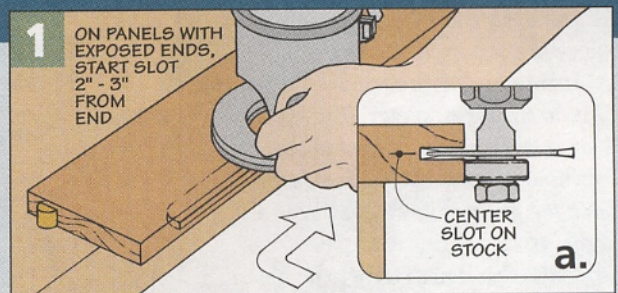
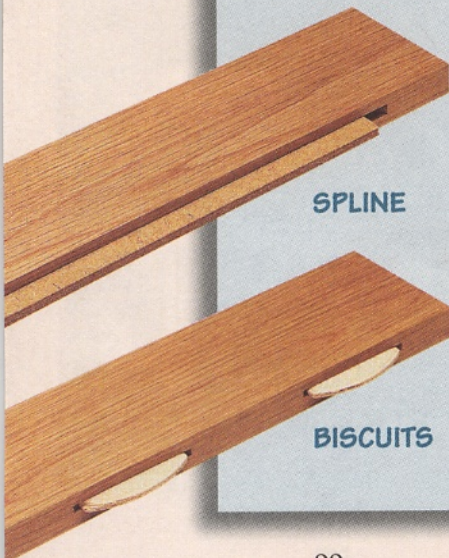

the surfaces align with each other.

If the boards aren't too far out of alignment ($1/16"$) you can clamp or tap any boards back into alignment (Figures 2a and 2b). But sometimes that's not enough. That's when I turn to splines or biscuits for a little help (see the box on the opposite page).

Besides surface alignment, I also check a few other things. For more on this, take a look at the box below.

GLUING UP THE BOARDS

With a dry run under your belt and any problems taken care of, you're ready to start gluing up the panel.

Glue - To speed things along, I squeeze out a bead of glue on one edge only of each board and brush it to an even film, as you can see in the upper margin photo on the opposite page. Note: I like to use yellow glue when making panels.

What you want here is the "wet" look. If the glue looks dull and flat, squeeze on a bit more and spread the glue back along the edge.

Since yellow glue sets up fast, you'll need to work quickly. So start by laying all the boards flat on the pipe clamps. Note: A strip of wax paper or masking tape between the pipes and your boards will prevent the glue from reacting with the pipes and creating black marks on the panel.

Tighten Clamps - Now it's just a matter of tightening the pipe clamps. I like to start at the center and work toward the ends, alternating between the top and bottom clamps. But don't overdo it here. You only want to apply enough pressure so there's an even bead of glue along the joint line (bottom margin photo on opposite page).

Align Boards - Here again, if you aren't using splines or biscuits, check the surface of the panel with a straightedge. Then tap (or clamp) any boards flush (Figures 2a and 2b).

Excess Glue - At this point, I used to wipe away the excess glue with a damp cloth. But this often forced the glue into the pores — causing finishing problems later.



Remove Glue.
A carbide-tipped scraper makes quick work of removing partially-dried glue from face of the panel.

What I like to do now is wait a couple hours until the glue sets up. This allows you take the clamps off and use a scraper to "pop" the glue off the surface (see photo above).

Even though the excess glue is removed, the glue in the joints needs to cure completely before you can work with the panel. But you don't want to lay it flat on a bench or floor to dry. Since air isn't free to circulate evenly around both sides of the panel, it could end up cupping.

Instead, set the panel on one end and lean it against a wall so it's as straight up and down as possible. This keeps the panel flat and allows the glue to fully cure from *both* sides.

Troubleshooting

Dry clamping a panel is a great way to discover problems *before* you start applying any glue. Here are a few things I check for.

Arrangement - One of the first things I verify is that the arrangement of the boards is correct. A quick check for the "V" makes it easy to see if any boards are out of order.

Joint Lines - Then I check the joint lines. One thing you might notice is a gap at the ends of the boards because of snipe, as shown in detail 'a.' To solve this problem, it's best to tune up your jointer and rejoin the edges.

And if I've used a table saw to square up the edges, I check them for saw marks, like the ones in detail 'b.' An edge with saw marks isn't smooth and can result in a weak glue joint. Here again, you'll want to retrim the edges.

Flat & Flush - Finally, check that the panel is flat and the surfaces are flush (details 'c' and 'd'). Here again, squaring the edges will remove any cup. And if the surfaces aren't flush, you can clamp the ends or tap them down against the pipe clamps. If you need some extra help, see the box on the opposite page.

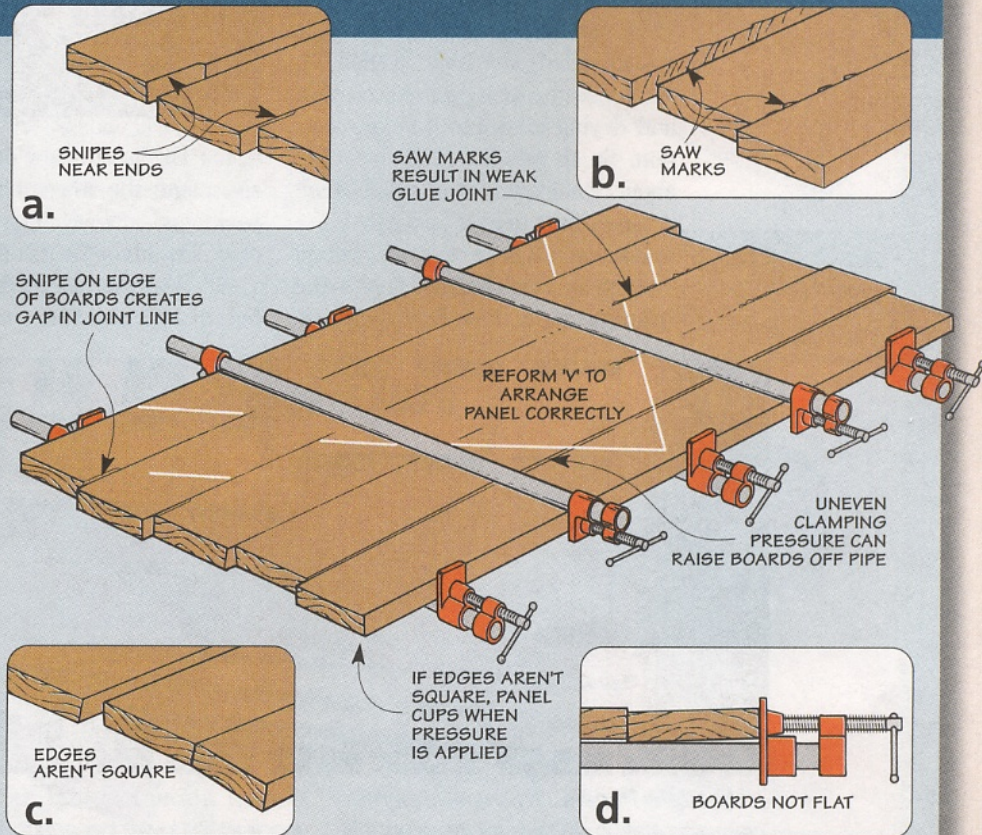

Wall-Mounted Clamping Station

Gluing up a panel is a breeze with this space-saving clamping station that mounts to the wall of your shop.

Clamping up a panel is a series of challenges. The first is clearing your bench to create a large enough area to work. The next challenge is setting up the pipe clamps to do the job. And finally, to reclaim your bench, you need to wrestle the panel (and clamps) off the bench and find a place to set it while it dries.

Clamping Station – To meet these challenges head-on, I built this wall-mounted clamping station. It combines the glue-up area, clamps, and drying area into a single location. So there's no need to worry about cleaning off a workbench when it comes time to glue up a panel.

You won't have to run around looking for pipe clamps either — the "clamps" are built in. As you can see

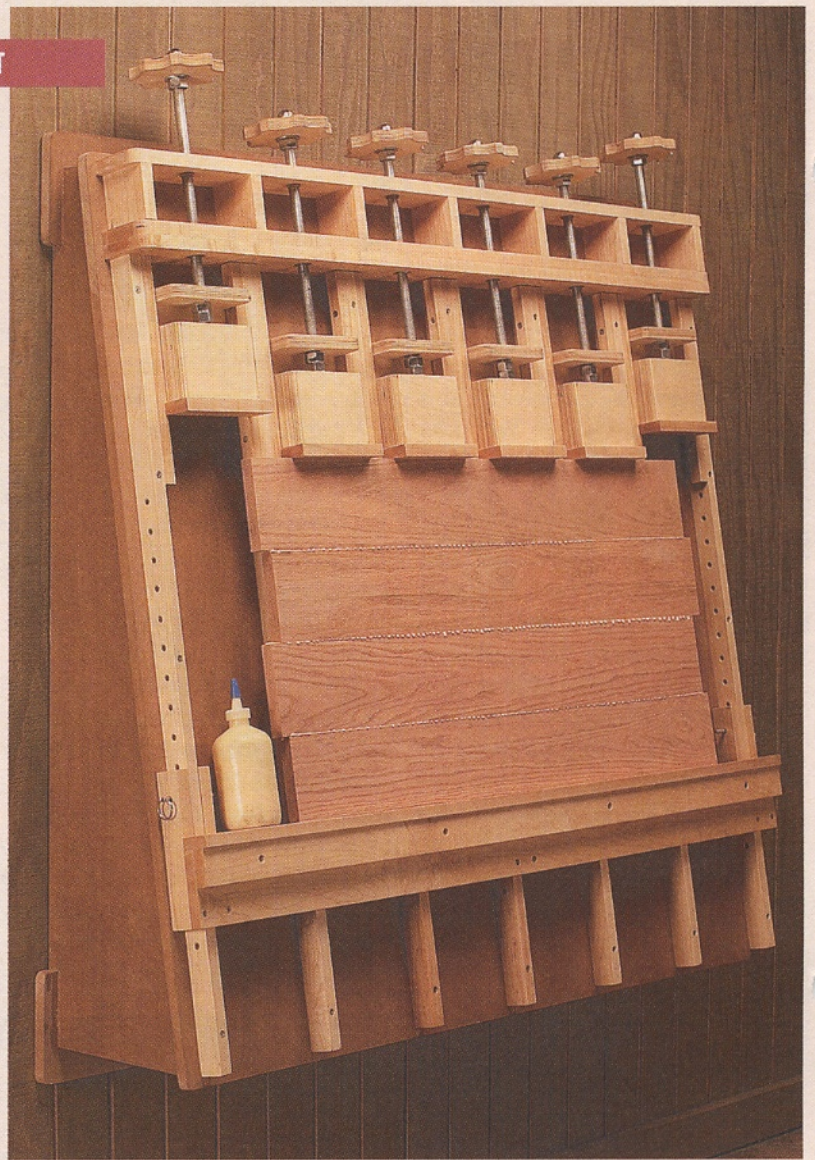

in the Exploded View on the opposite page, the lower clamp bar is positioned to accommodate the overall width of the panel.

Once you've placed the glued up boards in the station, simply tighten

the handwheels across the top of the clamping station. Finally, you won't have to lug the clamped up assembly away from your bench and find a place to "store" it until it dries. You simply walk away and wait for the assembly to dry right on the station.

Cost – Although the clamping station is large in size, building it won't cost you an arm and a leg. The medium-density fiberboard (MDF), plywood, maple, and few pieces of hardware cost much less than an equivalent set of pipe clamps.

As a matter of fact, many of the parts could be made using scraps you probably already have in your shop — reducing the cost even more.

One last thing, don't get the idea that this clamping station is just for large panels. It works just as well for gluing up smaller panels, as shown in the photo at left.



▲ **Multiple Panels.** This wall-mounted clamping station isn't just for large panels. Gluing up smaller panels (like the pair shown above) is just as easy. Just readjust the lower bar and then tighten the clamp heads individually for each panel.

ShopNotes To download a free Cutting Diagram for the Clamping Station, go to www.shopnotes.com.

GO ON-LINE EXTRAS

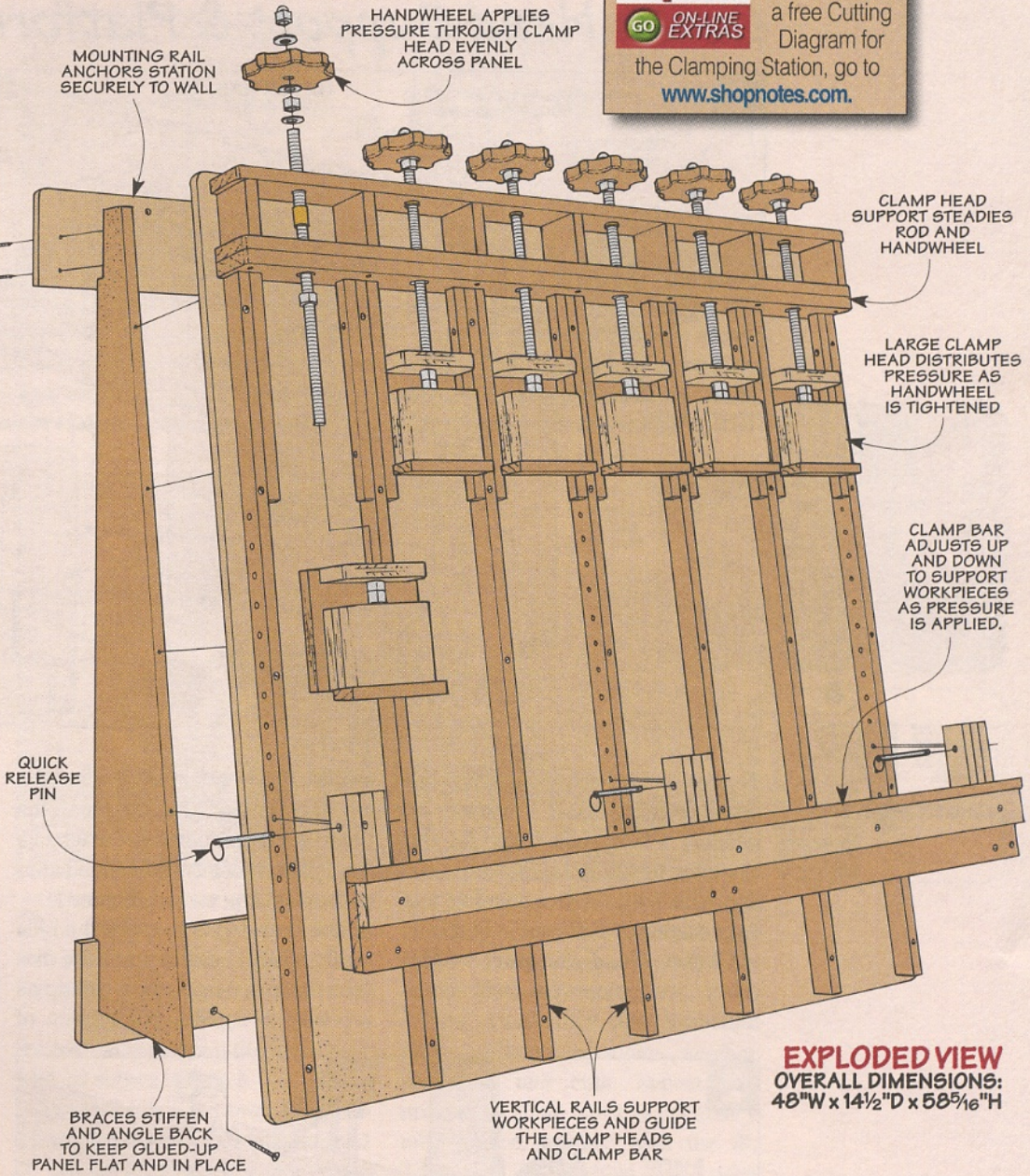
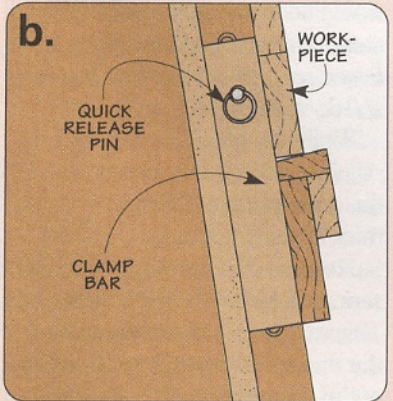
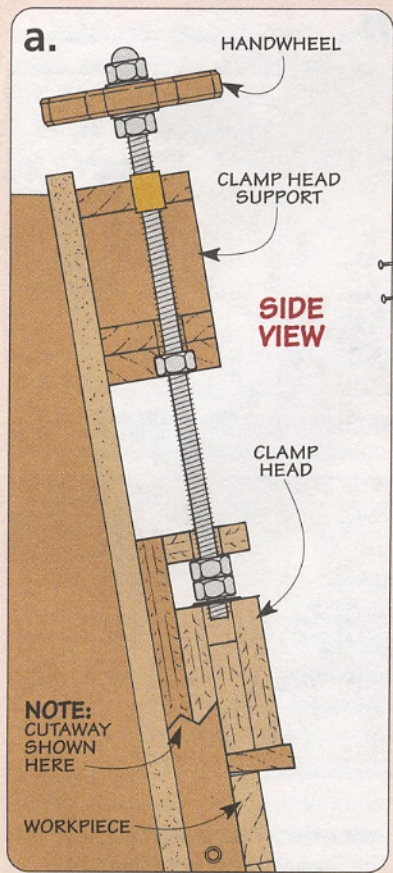

Materials

Clamp Head Support & Platform

- A Lower Rail (1) 1 1/2 x 3 - 46 1/2
- B Upper Rail (1) 3/4 x 3 - 46 1/2
- C Rail Spacers (7) 3/4 x 3 - 3
- D Back (1) 48 x 48 - 3/4 MDF
- E Braces (4) 11 x 46 5/16 - 3/4 MDF
- F Mounting Rails (2) 6 x 48 - 3/4 MDF

Vertical Rails & Clamp Bar

- G Vertical Rails (7) 3/4 x 1 1/2 - 41 3/4
- H Guide Strips (12) 3/4 x 3/4 - 12
- I Bar Rail (1) 3/4 x 4 - 48
- J Clamp Bar Guides (6) 3/4 x 1 1/2 - 8
- K Bar Stiffener (1) 3/4 x 2 - 48

- L Bar Face (1) 5/8 x 1 3/4 - 48

Clamp Heads & Handwheels

- M Bases (6) 6 11/16 x 6 - 3/4 Ply.
- N Clamp Bodies (6) 5 2/16 x 4 - 2 1/4 Ply.
- O Retaining Strips (6) 2 1/4 x 5 3/16 - 3/4 Ply.
- P Handwheels (6) 7 x 7 (rgh.) - 3/4 Ply.
- Q Clamp Head Faces (6) 5/8 x 1 1/2 - 5 11/16

Note: You'll need (1) sheet of Medium-Density Fiberboard (MDF), approximately 16 bd. ft. of 3/4"-thick hardwood, and (1) 2' x 4' piece of 3/4" plywood for this project.

Hardware

- (12) #8 x 1 1/4" Fh Sheet Metal Screws
- (107) #8 x 1 1/2" Fh Sheet Metal Screws
- (65) #8 x 2 1/2" Fh Sheet Metal Screws
- (6) 3/4" O.D. x 5/8" I.D. x 1"-Long Bronze Bushings
- (24) 5/8" Hex Nuts
- (18) 5/8" Flat Washers
- (6) 5/8" Acorn Nuts
- (3) 1/4" x 3 1/2" Quick Release Pins
- (6) 5/8"-Dia. x 15"-Long Allthread Steel Rods

Clamp Head Support & Platform

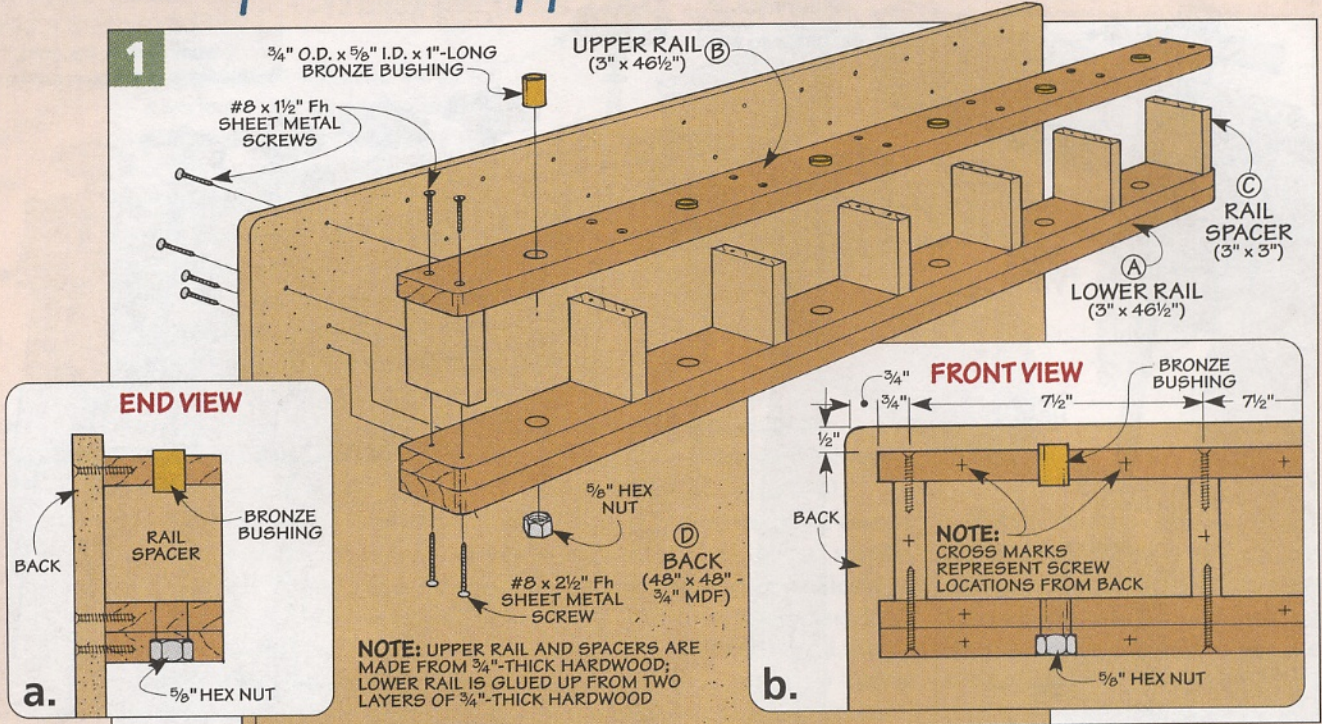

To provide firm support as clamping pressure is applied, I started by building a rock-solid frame for the clamping heads at the top of the station. This frame is then attached to a large platform, as shown in Figure 1.

Clamp Head Support - The clamp head support is built like a miniature wall with short "studs"

sandwiched between long rails at the top and bottom (Figure 1b). This frame is then mounted to the top of a large panel that forms the foundation of the clamping station (Figure 1).

The first step is to make the rails for the clamp head support. To prevent the lower rail from bending as pressure is applied, it's a piece of

extra thick hardwood (1 1/2"). Now the easiest way to make this rail would be to use a piece of 1 1/2"-thick stock. But you can also glue up the lower rail (A) from two layers of 3/4"-thick stock (Figure 1).

While the glue dries on the lower rail, you can size the upper rail (B) to the same width and length from 3/4"-thick stock (Figure 1).

Holes - The next step is to drill a series of holes through both rails. These holes provide a way to anchor the threaded rods that make up part of the clamp heads.

To prevent the clamp heads from binding as you adjust them, it's important for the holes to align with each other. So it's a good idea to drill all the holes at the same time. To do this, I used a few pieces of carpet tape to hold the two rails together, as you can see in Figure 2.

Start by drilling a deep counterbore in the bottom of the lower rail (Figure 2a). This counterbore will accept a large hex nut that the threaded rod feeds into, allowing the clamp head to adjust up and down (Figures 1a and 1b).

Once that's complete, all that's left

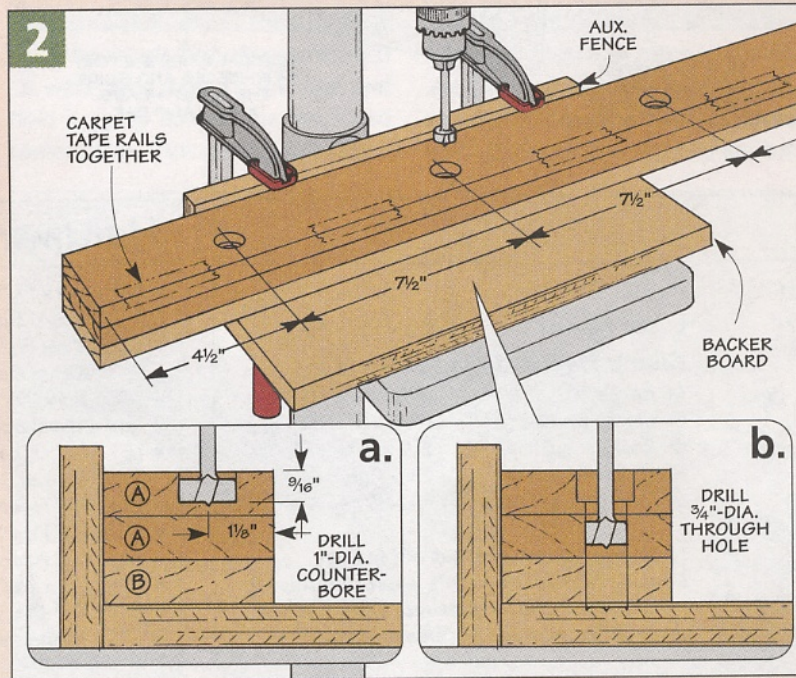

to do is drill a smaller through hole in both pieces. To prevent wear on the sides of the holes in the upper rails, these holes are sized to accept bronze bushings (Figure 1).

After drilling the holes, you can cut the *rail spacers* (C) to final size and screw the clamp head support together (Figure 1b). Finally, glue the hex nuts in place with epoxy and press the bushings into the top rail.

Platform – With the clamp head support complete, you're ready work on the platform. The first step here is to cut the *back* (D) to size. It's nothing more than a 48"-square piece of 3/4" MDF.

Attaching the clamp head support to the back is just a matter of screwing it in place (Figure 1a). To ensure the screws are located properly, take some time to lay out each location. After clamping the support to the back, drill the pilot holes and then screw the support in place.

Braces – Now you're ready to complete the rest of the platform. To keep the back rigid as clamping pressure is applied, it's attached to a set of braces (Figure 3). These *braces* (E) are tapered pieces of 3/4" MDF. The taper positions the back at a slight angle to make it easier to keep workpieces in place as you glue up a panel (Figures 3a and 3b).

Because of their size, I found it easiest to cut the braces using a circular saw and straight edge (Figure 4). After cutting the braces to size, you'll need to cut a pair of notches along the back edge of each one to accept a pair

3 FIGURE

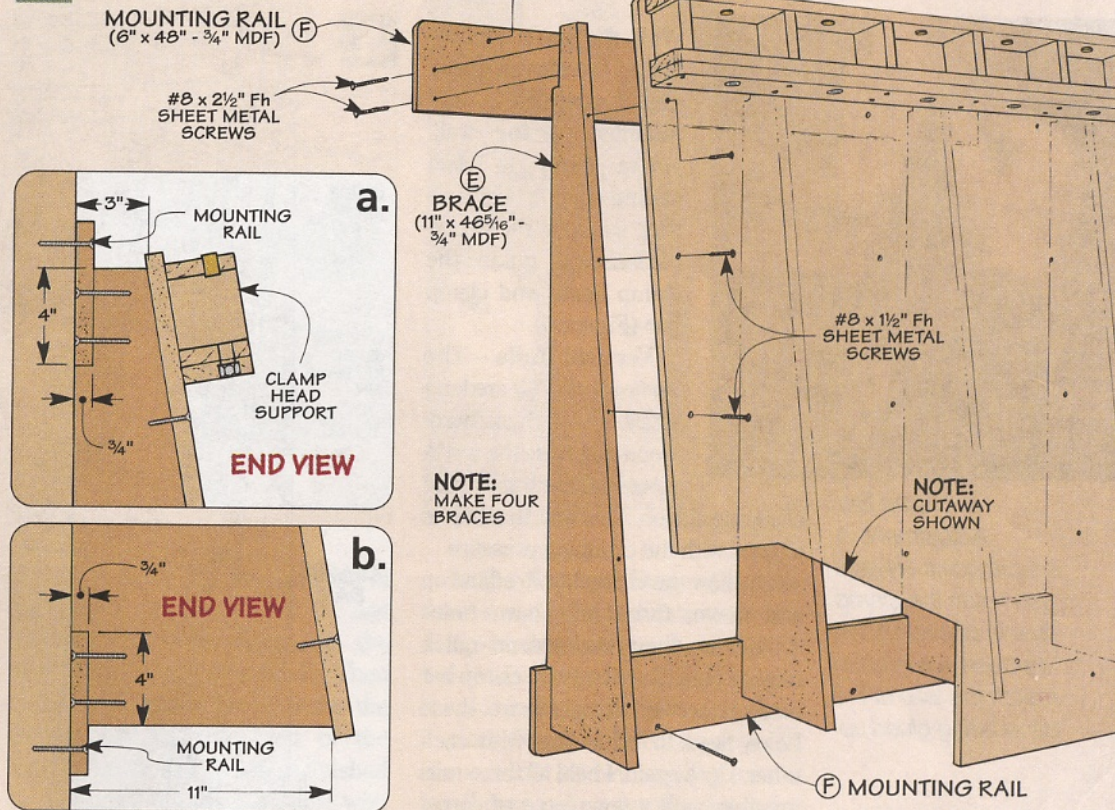

of rails (Figures 3a and 3b).

Now that the notches are cut, you can screw the braces to the back. Since the screws will be going into the edge of the MDF, I like to use sheet metal screws.

Unlike a tapered wood screw, the shanks of sheet metal screws are straight. So they're less likely to split the edge of the MDF.

Mounting Rails – Once the braces are screwed in place, you can cut the *mounting rails* (F) to size.

Here again, they're attached to the braces with sheet metal screws.

Mount Platform – Now's a good time to attach the platform to the wall. This solves a couple problems.

First, you don't have to worry about moving around a heavier assembly later. And second, it positions the clamping station at just the right height for adding the remaining parts.

Even so, the clamping station still weighs quite a bit. So you'll probably want a little help from a friend when you're ready to mount it to the wall. And to make the whole process easier, I screwed a cleat to the wall (see margin).

I attached the cleat so the top edge was about 16" from the floor. This puts the handwheels (added later) at a comfortable height.

Finally, be sure to screw through the mounting rails into at least three studs at both the top and bottom.



▲ **Cleat Support.** A temporary cleat makes it easy to keep the clamping station level when you attach it to the wall.

4

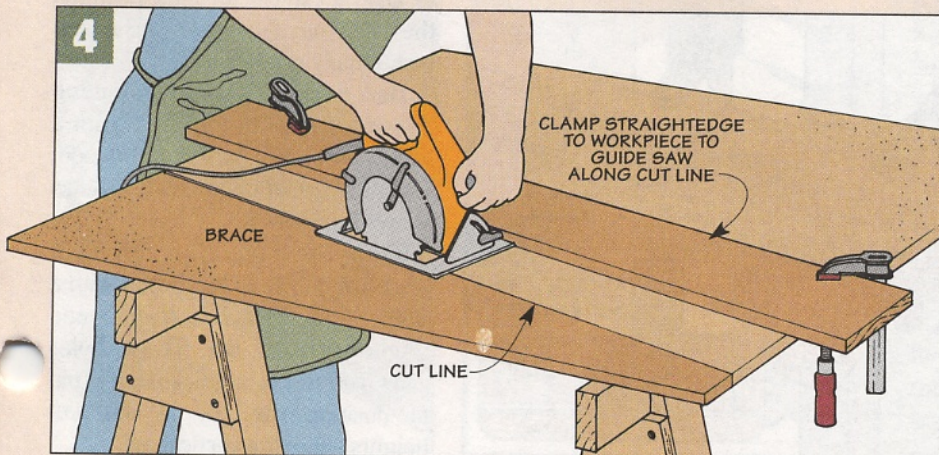

Vertical Rails & Clamp Bar



▲ **Clamp Bar Adjustment.** A simple quick-release pin holds the clamp bar in position once it's been adjusted to match the size of the panel being glued up.

With the basic foundation of the clamping station complete and mounted to the wall, you're ready to start adding the vertical rails that support the workpieces and guide the clamp heads and clamp bar (Figure 5).

Vertical Rails – The vertical rails (G) are long strips of 3/4"-thick hardwood that raise the workpieces off the back of the clamping station. This way, they're aligned with the clamping pressure.

To allow the clamp bar to adjust up and down, three rails have holes drilled in them to accept quick release pins. To ensure the clamp bar is even across the platform, these holes need to be in line with each other. Here again, I held all three rails together with a few pieces of carpet tape and drilled the holes (Figure 6). Then to allow the pins to slide easily in place, I chamfered the outside edges of each hole (Figure 6a).

Once the holes are drilled, you're almost ready to screw the rails in place. But first, you'll need to add some short hardwood strips to the top of each rail, as you can see in Figure 7. These *guide strips* (H) will keep the clamp heads against the back as they move up and down.

After cutting the guide strips to length (12"), attaching them is just a

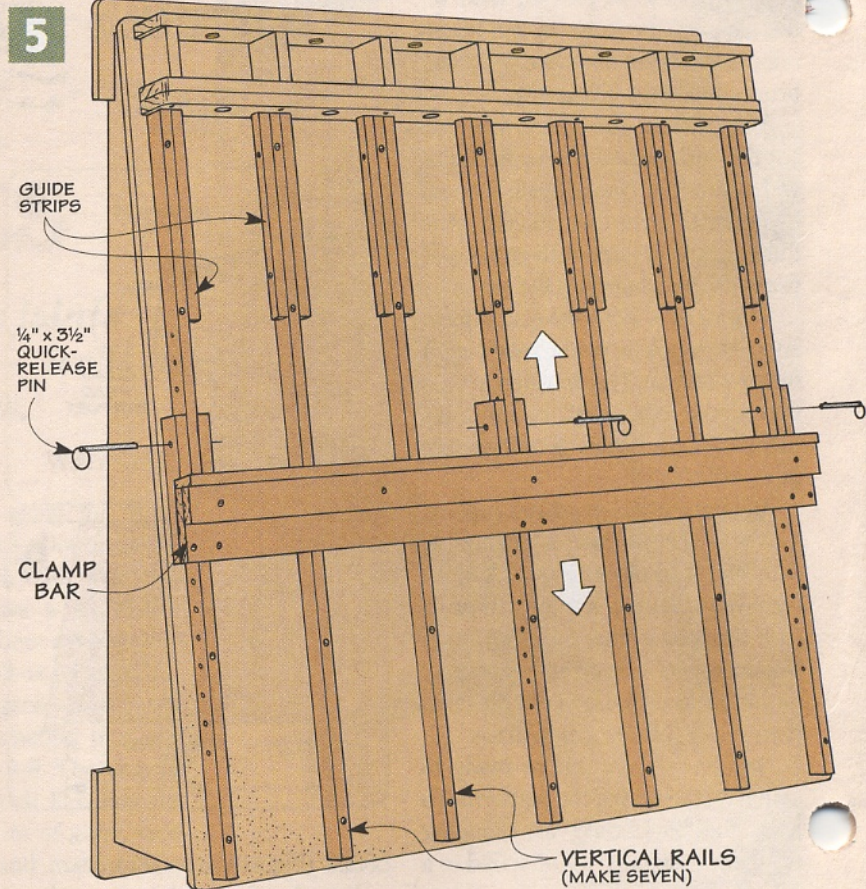

matter of gluing and screwing them in place, as you can see in Figures 7, 7a, and 7b. Note: The two vertical rails on the outside only have a single guide strip attached to the *inside* face (Figure 7a).

Now that the guides strips are attached, you can glue and screw the vertical rails to the back. The rails fit tight against the bottom of the clamp

head support at the top and they're spaced evenly across the back, as illustrated in Figures 7a and 7b.

Clamp Bar – At this point you can turn your attention to the adjustable clamp bar shown in Figure 8. The clamp bar is made from three separate pieces of hardwood attached to three pairs of guides. These pieces work together to form a rigid beam that prevents the bar from flexing as the clamp heads apply pressure.

Bar Rail – I started by cutting the *bar rail* (I) to final size from a wide piece of 3/4"-thick hardwood. Then I cut a set of guides to size, as shown in Figure 8.

These *bar guides* (J) are identical pieces of 3/4"-thick hardwood with a single hole drilled near one end (Figures 8 and 8c). These holes allow you to use a quick-release pin to position the bar at different heights along the vertical rail.

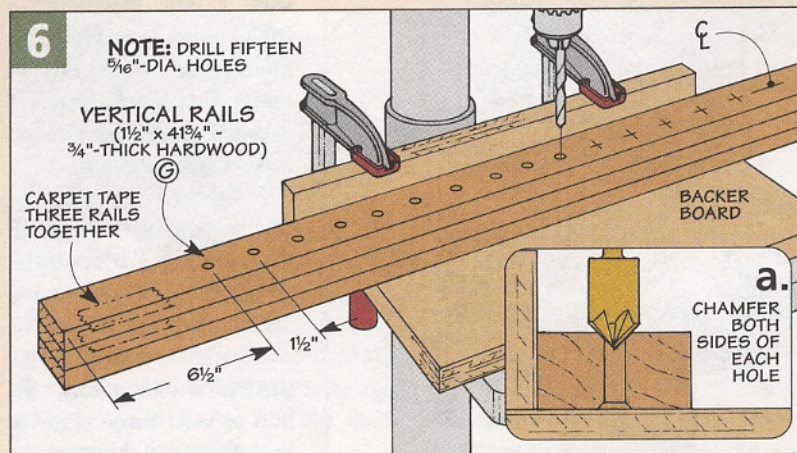

Assembly – Once the holes are drilled (and chamfered on each side as shown in Figure 6a), you can attach them to the bar rail. The trick is attaching the guides so they don't "pinch" too tight against the vertical rails. What you're looking for here is a smooth, sliding fit that doesn't bind as you move the rail up and down.

The solution is fairly simple. All you need to do is assemble the guides and bar rail right on the platform. To do this, start by "pinning" each pair of guides in place. Then slip a strip of paper between each guide and the vertical rail. This provides just enough "play" to allow the guides to slide easily.

Now all you need to do is clamp the guides against the rails. Then simply screw the bar rail in place so it's centered across the platform and flush with the bottom edge of each bar guide, as illustrated in Figure 8c.

Bar Stiffener – To provide additional strength and "beef up" the clamp bar, I added an extra strip of hardwood. As you can see in Figures 8 and 8b, the *bar stiffener* (K) is nothing more than a piece of 3/4"-thick hardwood that's glued and screwed to the face of the bar rail.

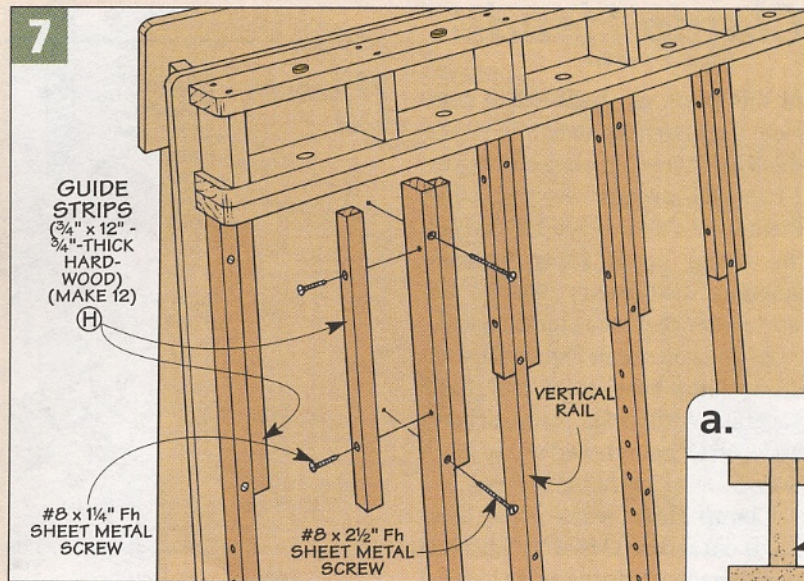

Besides stiffening the rail, it also provides support for the bar face that's added next. The *bar face* (L) is a piece of 5/8"-thick hardwood that rests on top of both the rail and stiffener (Figure 8c).

You'll notice that the bar face is slightly beveled (Figure 8c). This bevel forces the workpieces flat against the vertical rails as clamping pressure is applied.

Cutting a smooth, even bevel on a long strip is just a matter of tilting the

saw blade and making a long rip cut, as illustrated in Figure 8a.

All that's left to complete the clamp bar is to attach the bar face. Since the clamp face can be marred by the workpieces as you apply clamping pressure, I didn't glue it in place. Instead, it's attached with a few screws, as you can see in Figure 8. This way, you can replace it easily if necessary.

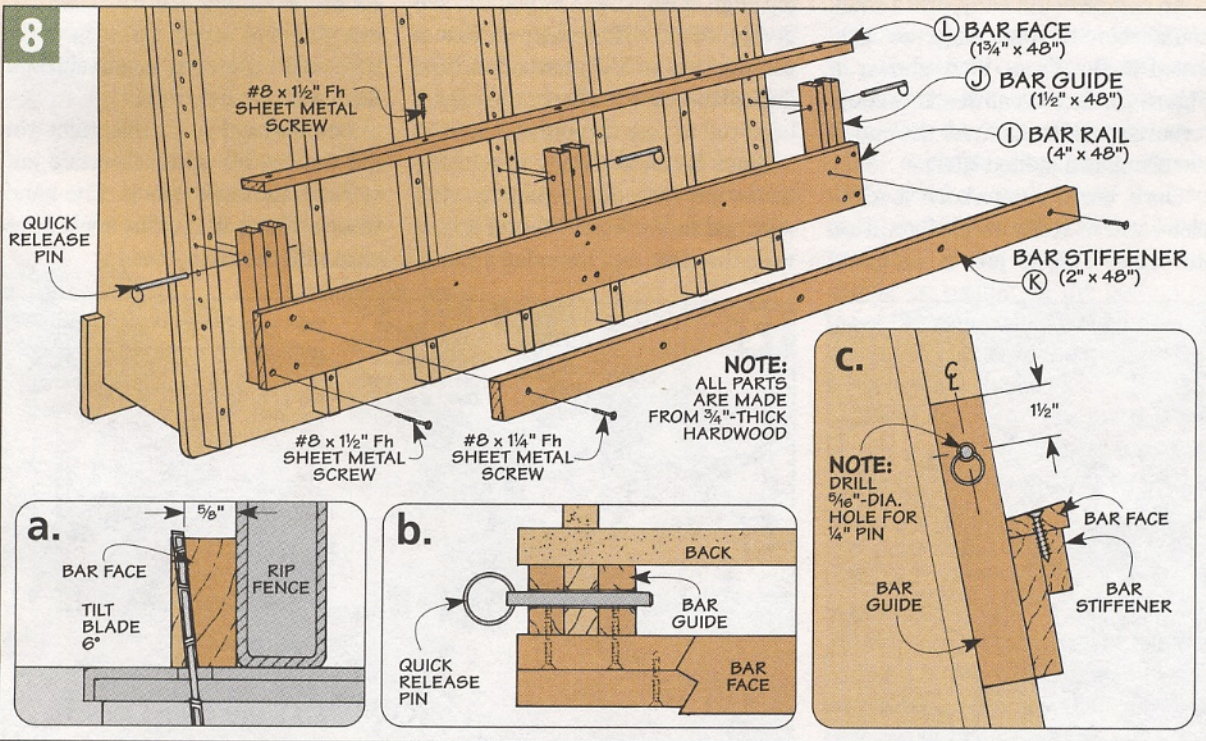
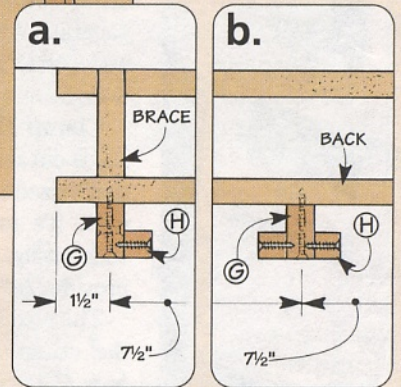

Clamp Heads

At this point, all that's left to complete the clamping station is to add the six clamp heads shown in Figure 10 and the margin. As you adjust them with a shop-made handwheel, the clamp heads apply pressure smoothly and evenly against the workpieces that make up the panel.

As you can see in Figure 10, each clamp head consists of four basic parts along with a few pieces of hardware. Note: I purchased all the hardware from a local home center.

Clamp Head – The clamp head starts out as *base (M)* of 3/4" plywood that's sized to fit between the vertical rails. It's important that the base slide easily, so I sized each piece to provide 1/16" clearance overall.

The next step is to add the body of the clamp. Here again, the *clamp body (N)* is made from 3/4" plywood. But this time it's glued up from three layers. I found it easiest to start with long strips of plywood and glue them up into an extra-long (30") blank.

After rounding over the two top edges, all you need to do is cut each body to size by "slicing" off short (4") sections (Figure 11).

To complete the body, drill a small counterbore in one edge, as illustrated in the Front View shown in Figure 10. As you can see, this counterbore provides room for the end of the clamp rod (added later).

Once each counterbore is complete, you're ready to position it on the base. This is just a matter of

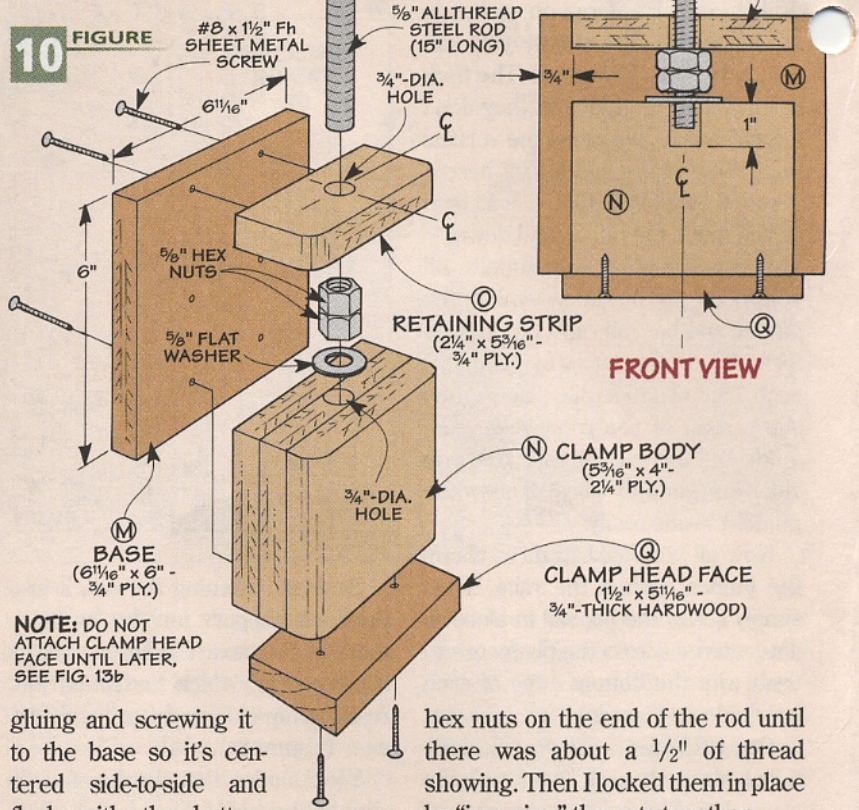

gluing and screwing it to the base so it's centered side-to-side and flush with the bottom edge. Just be sure the hole for the threaded rod faces up.

Retaining Strip – To hold the clamp head to the threaded rod, I added a *retaining strip (O)* along the top edge of each base, as you can see in Figure 10. This piece is just a narrow strip of 3/4" plywood. A hole drilled through it allows the clamp head rod to pass through.

Since it can be tricky to add the hardware with the retaining strip attached to the base, I found it best to do that first. So I threaded a pair of

hex nuts on the end of the rod until there was about a 1/2" of thread showing. Then I locked them in place by "jamming" the nuts together.

Now you can slip the rod through the retaining strip. Before attaching the strip to the base, slip a washer over the end of the rod and fit it into the counterbore in the body (see Front View in Figure 10). Then you can glue and screw the strip to the base so it's centered side-to-side and flush with the top edge.

Handwheel – At this point you can set the clamp heads aside and work on the handwheels. The handwheels make it easy to apply pressure with the clamp heads.



▲ **Clamp Heads.** Individual clamp heads are used to apply pressure evenly across the top edge of the panel.

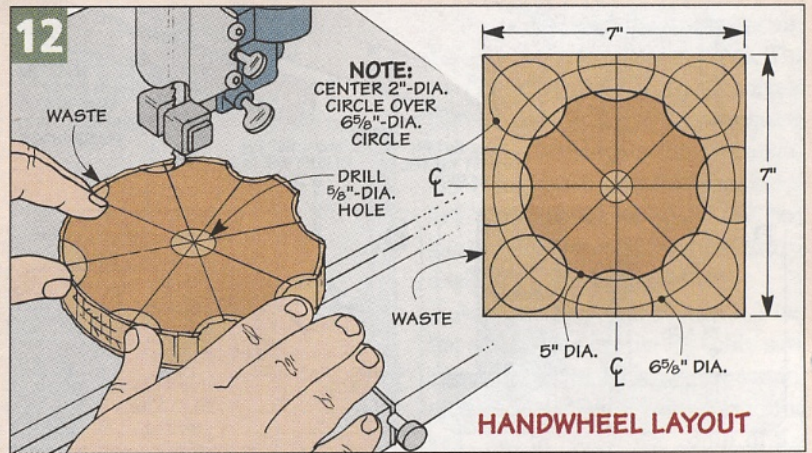
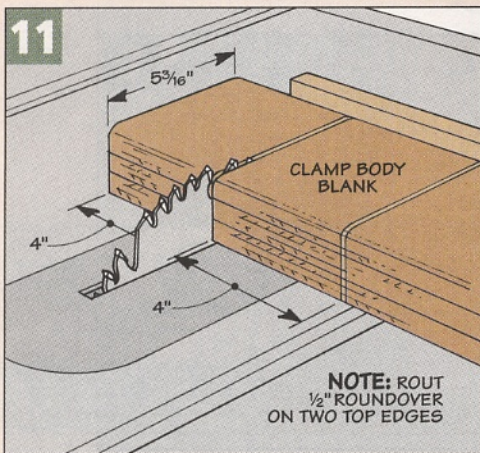

Each *handwheel* (P) starts out as a 7"-square blank of 3/4" plywood. Then to create the shape of the finger grips, I laid out a series of holes in each blank (see Handwheel Layout in Figure 12).

Drilling the center hole is easy, it's only 5/8" in diameter. But drilling the holes that help create the finger grips requires a rather large bit (2").

Don't worry if you don't have a bit that size. You can easily cut the handwheel to shape on the band saw (Figure 12). Then all that's left to do is drill a centered hole. Note: To remove the sharp corners, I softened the edges by sanding a small roundover.

Assembly – Now you're ready to complete the final assembly of the clamp head. To do this, slip the base of each clamp head under the guides and thread the clamp head rod into the hex nut on the bottom of the clamp head support.

Then you can add the rest of the hardware (Figure 13). The object here is to sandwich the handwheel between the hex nut and acorn nut.

After repeating this process for each clamp head, all that's left to do is add the *clamp head face* (Q). Like the clamp bar (Figure 8a), a matching bevel cut along the face (Figure 3b) forces the panel down against the vertical rails. Here again, the clamp

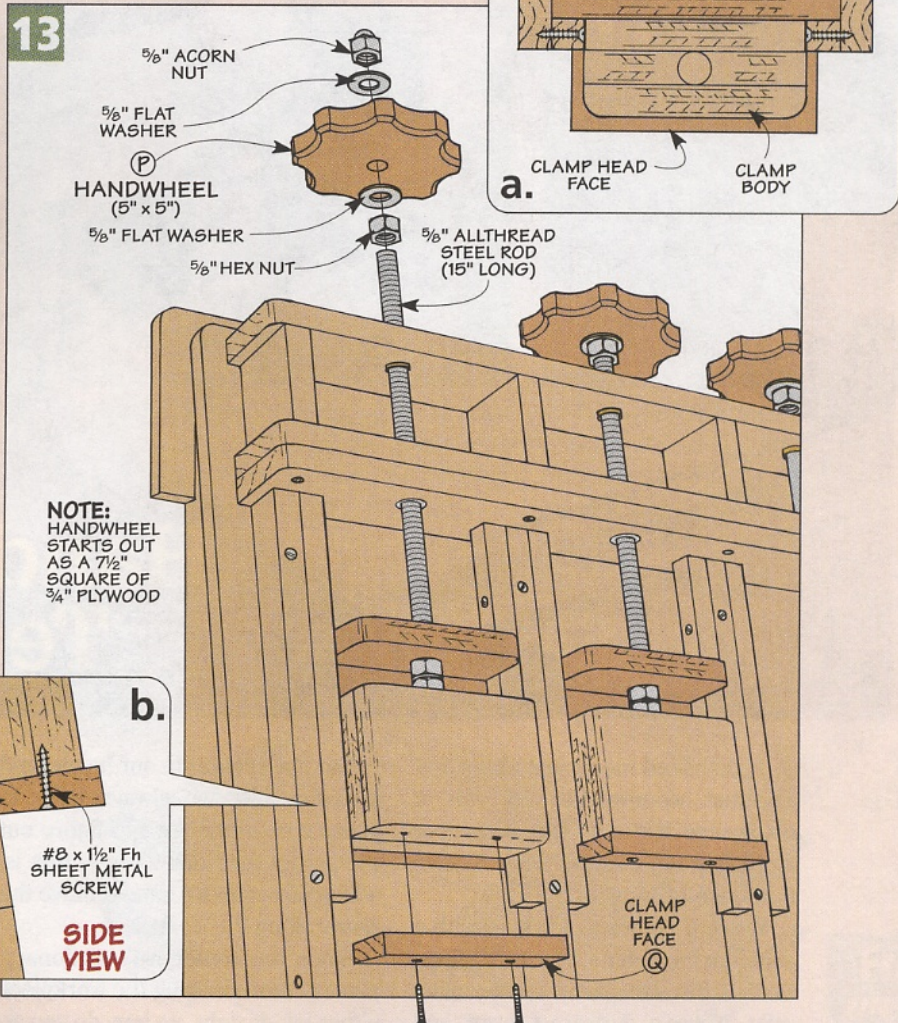

head face is only screwed in place. And it's centered side-to-side on the clamp body and rests against the guides (Figures 13a and 13b).

Glue Up A Panel – Now that the clamping station is complete,

you're ready to glue up a panel. There's nothing tricky here. It's a simple step-by-step process, as you can see below. After tightening the last clamp head, all you need to do is wait for the panel to dry.



▲ **Apply Wax.** To prevent glue (and the panel) from sticking to the station, rub paraffin wax on the vertical rails.



▲ **Add Glue.** After adjusting the lower clamp bar, apply glue to each workpiece and stack to form panel.

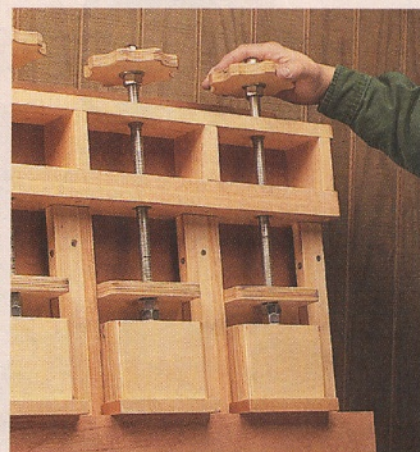

▲ **Clamp.** With the workpieces in place, apply pressure evenly across the panel by tightening each clamp head.

Shop Talk

Want to make your hand-held routing trouble-free? Try the shop-tested tips below.

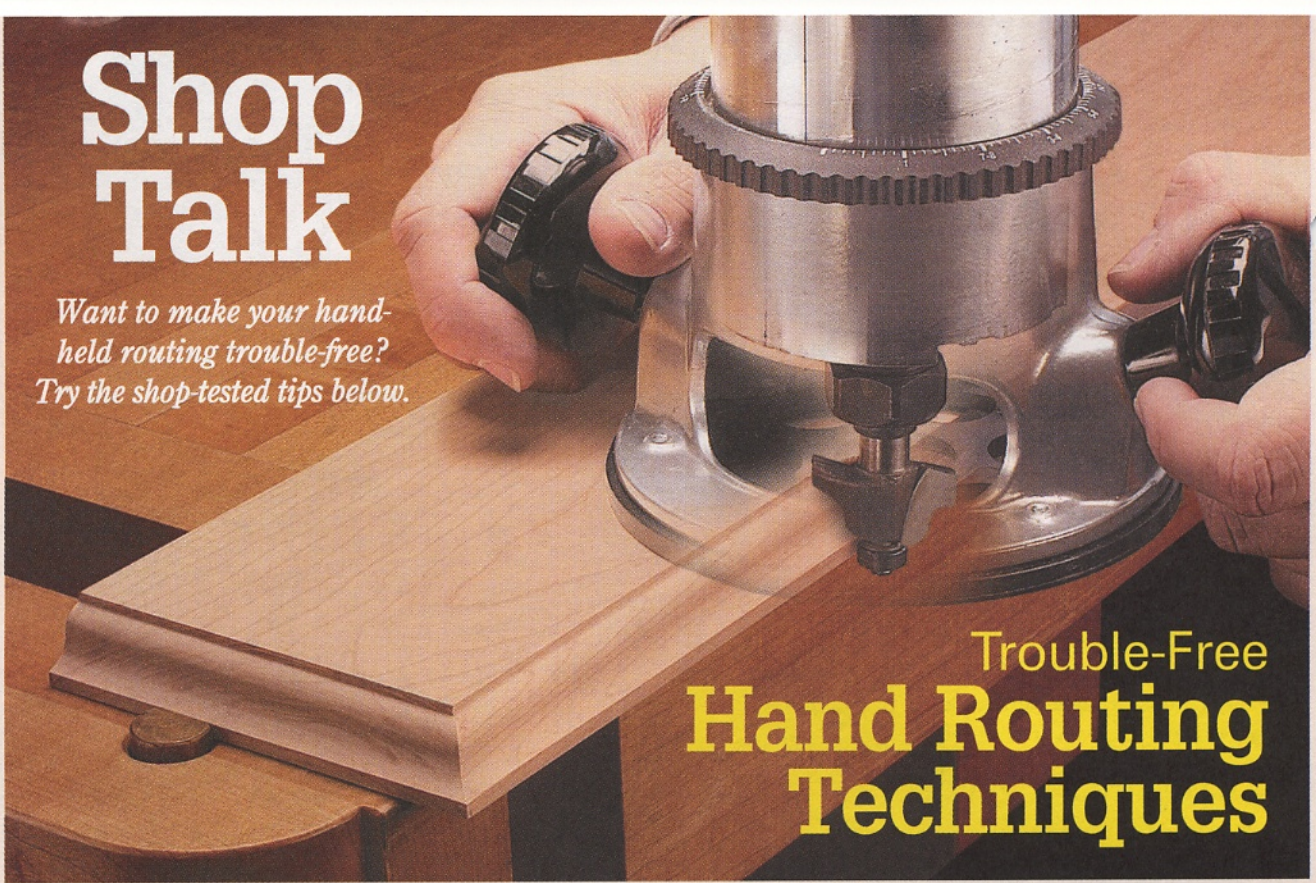

Trouble-Free Hand Routing Techniques

If you asked me or just about any other woodworker to run a workpiece through the jointer or table saw, we wouldn't have to give it a second thought.

When it comes to working with a stationary machine, the feed direction of the workpiece comes naturally. There's a distinct front and back to most machines, and therefore, the feed direction is automatic.

But put a router in our hands, and it seems like we always have to pause a second or two to figure out the proper feed direction — that is, which direction we should move the router along the workpiece.

Since the router isn't stationary, you can move it along the workpiece either left or right. So how do you go about figuring out what's "right?"

Right Hand is "Right" — The simplest method I've found for determining the proper routing direction (no matter what I'm routing) is something I have with me all the time — my right hand. Take a look at the detail at left, and you'll see what I mean.

Start by making an 'L'

with the thumb and forefinger of your right hand so the knuckles face up. Then with your 'L' "in hand," all you need to do is point your thumb towards the edge of the workpiece you're routing. A quick look at the direction your finger points tells you which way you need to move the router along the workpiece.

What's really nice is this method works whether you're routing the inside (clockwise direction) or outside (counterclockwise) of a workpiece, as shown in the Routing Frames drawing.

And if you need to move the router along a fence to rout a groove or dado, it works just as well (Routing with a Fence drawing). But instead of your thumb pointing to the workpiece, it will point to the fence. Here again, your finger will point in the proper direction to move the router.

Breaking the Rules — This method works for most situations. But like most rules you've probably learned, this one is made to be broken. Sometimes wrong is "right." For more on this, take a look at the box on the opposite page.

Preventing Chipout — Even when you're routing in the "right" direction, you'll inevitably run across

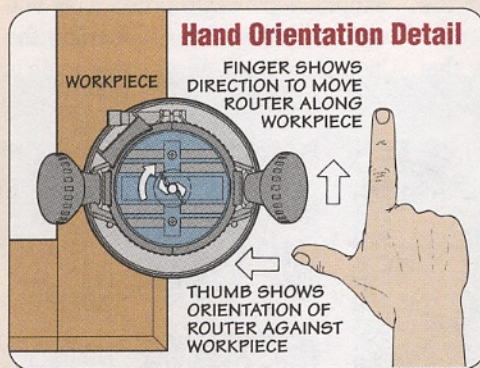

Routing Frames

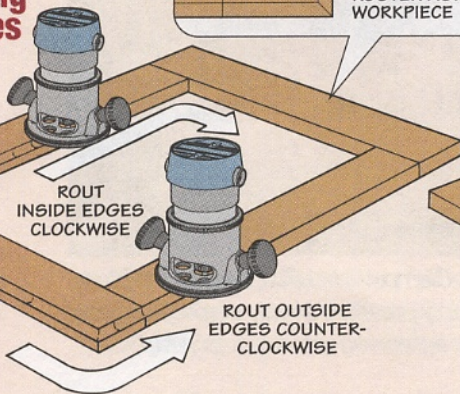

Routing with a Fence

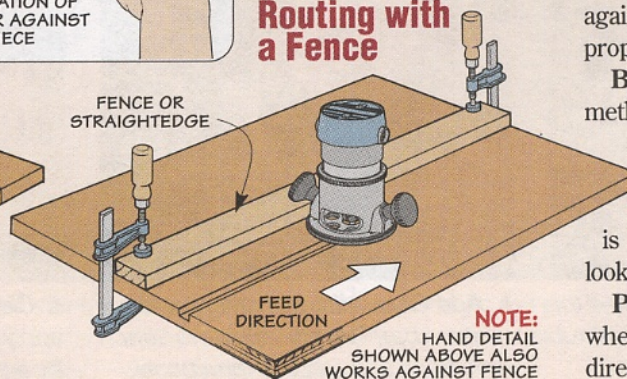

one of the more frustrating problems in woodworking — chipout. It's happened to me more times than I care to remember. And if you look at the left drawing in Figure 1 below, it's easy to see why this happens.

As you rout along the edge, the bit has the support of the uncut profile to prevent the wood from chipping out — until the bit exits the cut at the end of the workpiece. This happens most often when you're routing across the *end grain* of a workpiece.

Ends First — So what's the solution? The one I like to use is to rout the ends of the workpiece *first*. Sure,

I still get splintering at the end of the pass. But once I rout the profile along the sides of the workpiece (which are edge grain and rout more smoothly), the chipped-out areas “disappear,” as you can see in the right drawing of Figure 1.

Support Scrap — That sounds great. But what if you're *not* routing all the way around a workpiece? For instance, I typically don't rout the back edge of a top where it's going to be against a wall.

If that's the case, there's still a way to prevent chipout. All you need to do is temporarily clamp a scrap of

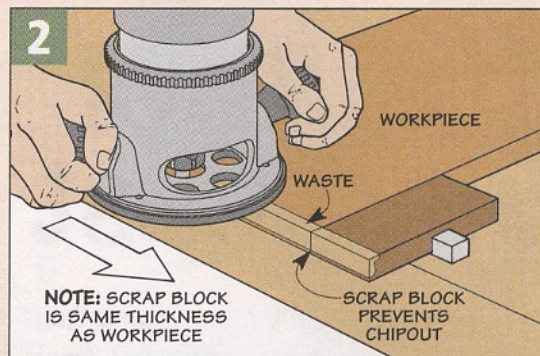

wood against the edge that isn't going to be routed, as shown in Figure 2 above.

The scrap backs up the wood fibers at the corners of the workpiece. So when the end grain is routed, any chipout will end up on the scrap — not on the workpiece.

However, when routing end grain, it's still a good idea to minimize chipout. So *don't* set the bit for a full depth cut. Instead, take a series of shallow passes, finishing up with a very light final pass.

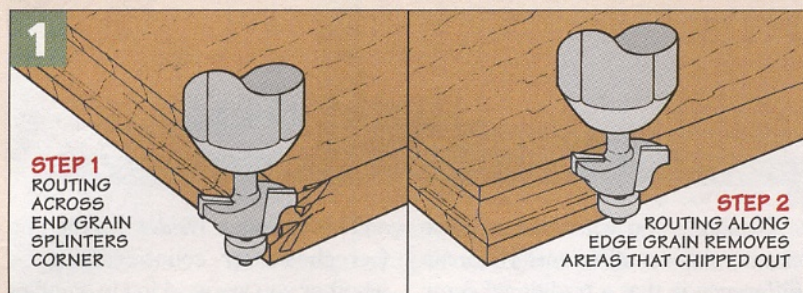

Backrouting Basics

Although I try to rout in the “proper” direction most of the time, I'll have to admit there are a couple occasions when I break the rules — and do a little backrouting.

Backrouting — So what exactly is backrouting? As the name implies, it's guiding the router *backwards* along the edge of a workpiece.

But if it's not “right,” why backroute at all? The main reason is that routing in the proper direction can be a lot like rubbing a cat's fur the wrong way. It makes the grain stand up, or chip out, along some of the edges. Backrouting “smooths” the wood and prevents this from happening.

Rabbets — I like to backroute when I need to cut a rabbet to hold a glass panel — the last thing I want to end up with is chipout. So instead of routing in the normal direction, I backroute and make a very shallow, full-width cut (Figure 1).

This lightly “scores” the edge of

the rabbet. Once that's complete, you can make the rest of the cuts to the full depth of the rabbet routing in the proper direction (Figure 2).

Ovals & Circles — I also like to backroute when I have to rout a profile on the edge of an oval or circle. Since there isn't a square corner, there isn't any specific end grain you can rout first. So I backroute instead.

Here again, you'll want to take several very light cuts until you reach the full depth of the cut. Then to remove any chatter marks, make a final pass with the router in the normal direction.

Safety — So why not backroute all the time? The problem is the bit won't pull itself into the wood — it will bounce and skip along the edge, making the router difficult to control. To minimize this problem, I like to take light passes and keep a firm grip. Then I take a final cut in the proper direction to clean up the edge.

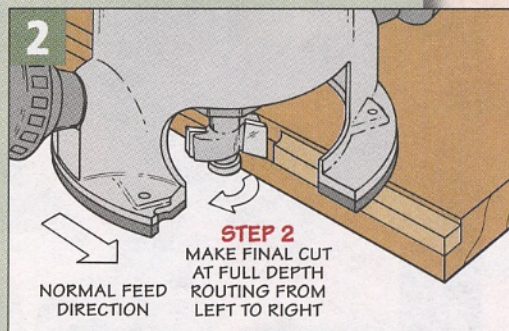

Safety Note: There's one very important thing to keep in mind here. *Never* backroute on a router table — the workpiece (and your fingers) can be pulled right into the router bit.

Tool Chest

Looking to put a new twist on countersinking? Try a Weldon countersink bit.

One of the things that sets a good project apart from a great one is the details. And one of the less obvious details is drilling the countersink for the head of a screw.

A smooth, even countersink not only looks better, but it allows the head of the screw to seat fully. So it's less likely to project above the surface or look offset in the countersink.

That's a problem I've had with most of the countersinks I've used in the past. They tended to leave behind a rough, uneven surface in the workpiece.

Weldon Countersinks — But that all changed when I discovered a set of countersinks made by the *Weldon* company. The cutting edge works like a miniature plane to smoothly remove the waste as it cuts the countersink.

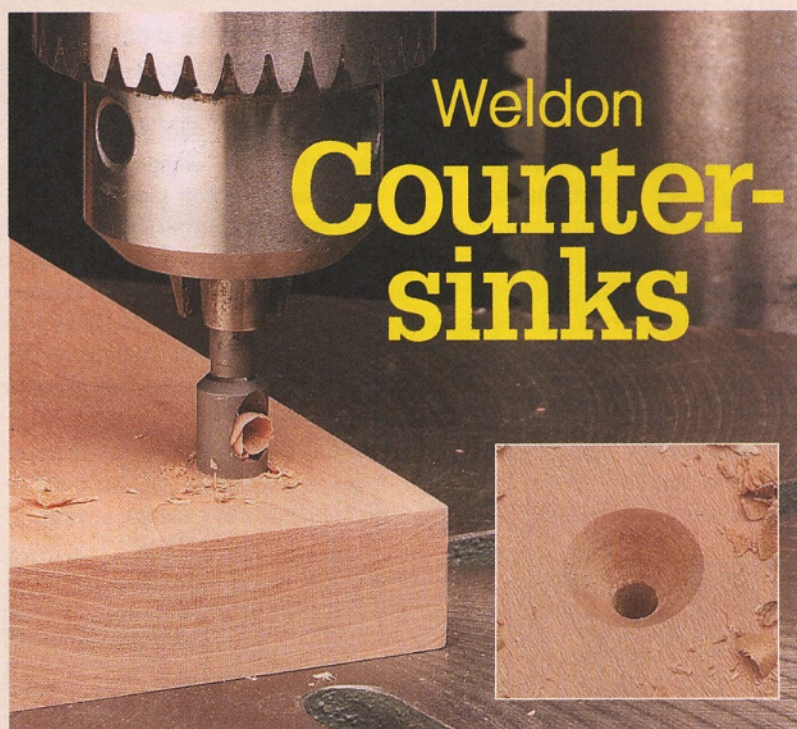

Sources

- **Schlabaugh & Sons:**
www.schsons.com/jigs
800-346-9663
- **Woodcraft:**
www.woodcraft.com
800-225-1153
- **Lee Valley Tools:**
www.leevalley.com
800-871-8158



▲ **Metal Work.** Smooth countersinks in soft metal, like brass or the aluminum shown above, are a snap with a Weldon countersink.

Design — So what makes these countersinks so different? The main difference is that a traditional countersink bit is “fluted.” These flutes remove material by “reaming” out small chips. The problem is they tend to “chatter,” leaving a wavy surface. This prevents the head of the screw from fully seating.

But instead of flutes, the *Weldon* bits have an *angled hole* drilled through the middle of the bit (see drawing below). Drilling this hole through the side of the bit results in a single cutting edge. And since there's only one cutting edge, you get a super-smooth countersink with curly shavings and chips, much like a hand plane (see the photo above).

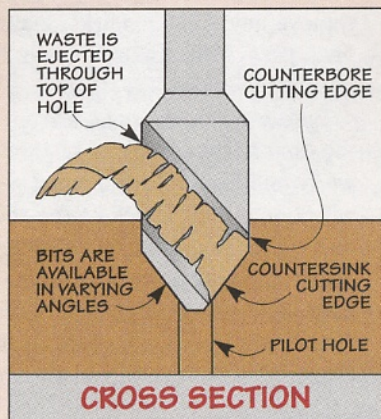

This makes a *Weldon* bit the perfect choice for countersinking — whether you are working in wood or metal (lower left photo). And I seem to be working with both materials a lot more often these days.

Note: Like most other countersink bits, you will need to drill the pilot hole for the screw before cutting the countersink.

Weldon countersinks come in various sizes and styles depending on the type and size of screw you're using. And they also come in differing cutting angles. (For wood screws, you'll need the 82° angle.)

Price — Depending on your needs, you can buy a single countersink for as little as \$8.00. But if you use a number of different screw sizes like I do, a three- or four-piece set is a better value. I paid \$30.00 for a four-piece set that will handle countersinks for #4 to #10 size screws. (See margin for photo and sources.)

As you may have guessed, I'm a big fan of *Weldon* countersinks. They're easy to use and cut flawless countersinks in both wood and metal. So if you're looking to make your woodworking a “cut above” the rest, add a set of *Weldon* countersink bits to your tool collection. 🛠️

Sources

Carpenter's Toolbox

To give the Carpenter's Toolbox (page 14) a classic look, I used some traditional trunk hardware, as you can see in the photo at the upper right. This type of hardware is available from a number of different sources. I ordered mine from *Lee Valley Tools*, but the margin at right lists other sources as well.

The 1/4"-thick leather trunk handle is 8 3/4" long and comes with a nail to secure the handle inside the brass loops. The draw catches are

1 1/2" wide and 2 3/4" long, and the trunk hinges are 1 1/8" wide and 2" long. One thing to keep in mind with all these parts is that you'll need to supply your own screws. You'll need six #8 x 3/4" Rh brass woodscrews for the handle and a total of eighteen #6 x 1/2" Fh brass woodscrews for the draw catches and hinges.

Aging Hardware - Regardless of where you get your hardware, it's going to come with a bright brass finish. To "tarnish" the brass and give it more of an aged look, I turned to an antiquing solution that darkens brass. (A couple sources are listed in the margin at right.)

Before using the darkening solution, be sure to read the instructions thoroughly. Since they're mildly corrosive it's a good idea to cover your work area with a piece of plastic. And be sure to wear safety goggles and rubber gloves.

In order for the the solution to work, you'll have to remove the protective coating from the hardware first. To do that, simply soak the hardware in lacquer thinner.

At this point, aging the hardware is just a matter of dipping it in the solu-

tion and letting the darkening process begin. I only kept the hardware in the mixture for a few minutes to get the look I was after.

When you have the look you want, remove the hardware and rinse it off with water to stop the process. Then to preserve the "look," I sprayed on a few thin coats of lacquer (*Defl*).

Leather - If you like the look of the leather trunk handle you can use it as is. But I decided to "age" it too. No need for a fancy solution here. I simply picked up some shoe polish (brown) at the grocery store, wiped it on, and then buffed it out.

ON-LINE EXTRAS

You don't have to build the Carpenter's Toolbox with box joints. We've also designed another version that uses simple rabbet joints. You can find more information about this version at our website at www.ShopNotes.com.

Or you can have the information mailed to you. Just send a stamped, self-addressed #10 envelope to:

ShopNotes Drawings
P.O. Box 842
Des Moines, IA 50304



MAIL ORDER SOURCES

Constantine's
954-561-1716
www.constantines.com
Toolbox Hardware

Lee Valley Tools
800-871-8158
www.leevalley.com
Toolbox Hardware,
Stainless-Steel
Canisters

Rockler
800-279-4441
www.rockler.com
Toolbox Hardware

VanDyke's Restorers
800-558-1234
www.vandykes.com
Brass Darkening
Solution

Woodsmith Store
800-835-5084
Brass Darkening
Solution

Before



After



▲ **Aging Hardware.** Giving the brass an aged look requires time — or a little help with a brass darkening solution (refer to margin for sources).

Hardware Canisters

As I was looking through catalogs to find just the right hardware for the Carpenter's Toolbox, I ran across these handy storage canisters.

They're made from stainless steel, so they're pretty tough. And the lids have a piece of clear plastic on top. So you don't have to remove the lid to see what's inside — a quick glance is all it takes.

And unlike a lot of small containers where the lid fits loosely, the lid on this canister pops on and off with a satis-

fyng "snap." So you don't have to worry about knocking a lid off and spilling the contents on the floor (or inside your toolbox).

Each canister is 2 3/8" in diameter and 3 3/8" tall — perfect for storing all sorts of small pieces of hardware (or other small items).

I ordered these canisters from *Lee Valley Tools*.

Besides these canisters, they also have a wide assortment of other storage containers. See margin for ordering information.



ShopNotes

on the web

- "Online Extras" - Plans, Patterns, & More
- Over 100 Woodworking Tips Online
- Forums for Woodworking, Tools, & Classifieds
- Visit Our Woodworking Shop Tours Gallery
- Project Plans You Can Download
- Catalog of Project Kits, Tools, Jigs, & Plans
- Links to Other Woodworking Sites
- Order *ShopNotes* & *Woodsmith* Back Issues

Online Customer Service

Click on Subscriber Services at www.shopnotes.com

- Access your account status
- Change your mailing or email address
- Pay your bill
- Renew your subscription
- Tell us if you've missed an issue
- Find out if your payment has been received

www.shopnotes.com

Scenes from the Shop



▲ Here's an opportunity to build your own antique toolbox. With its traditional-looking box joints and aged brass hardware, this classic toolbox is the perfect place to house your favorite hand tools. It's just the right size to set on a workbench or carry to a jobsite. Plus a convenient, lift-out tray makes a handy tote for hardware or smaller tools. Complete plans for this project begin on page 14.