

Lumber Selection
SECRETS

PERFECT TONGUE & GROOVE JOINERY ON YOUR TABLE SAW

ShopNotes®

Vol. 11

Issue 66

Improve your Router Table –
6 STEPS TO SUCCESS

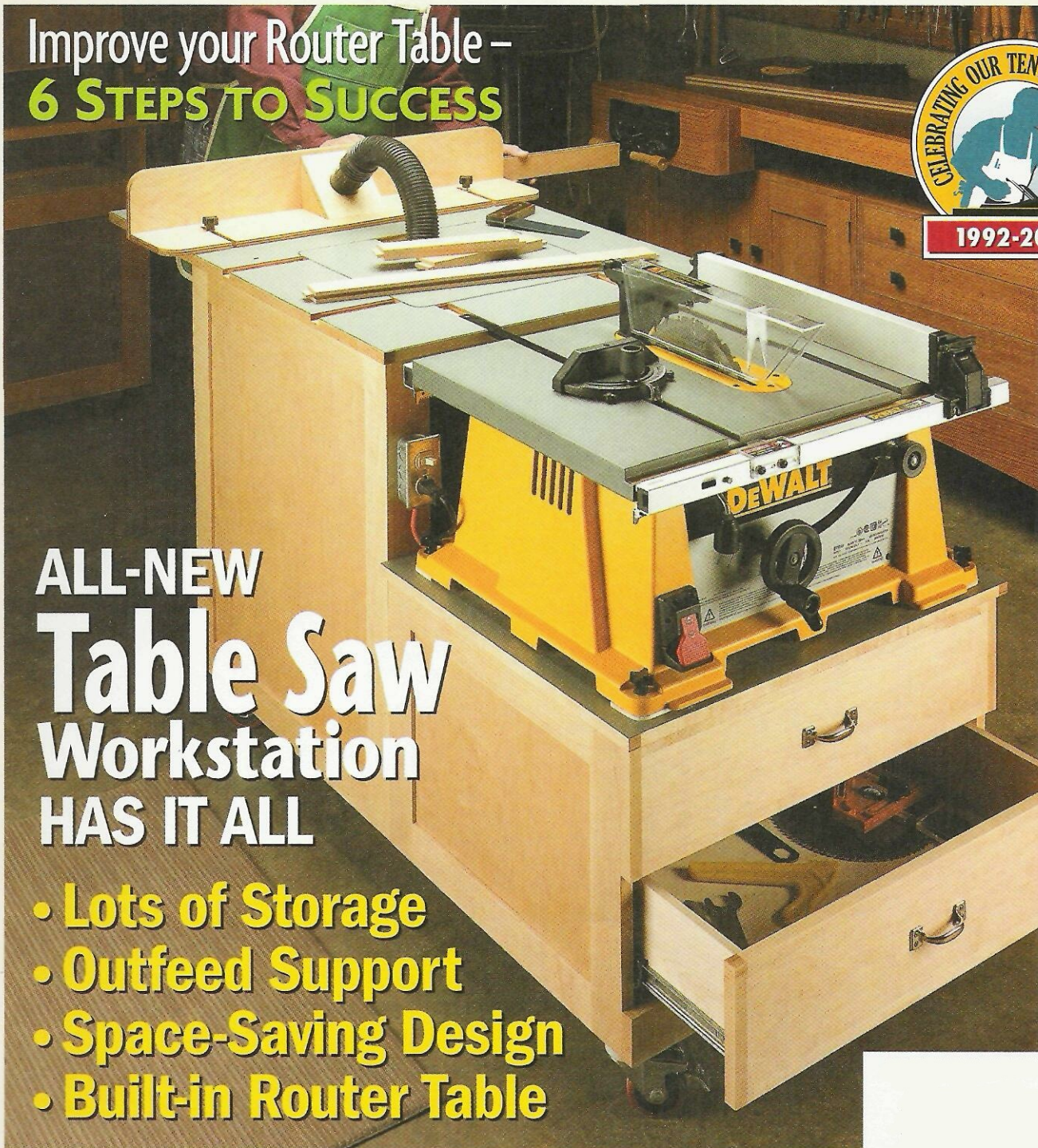
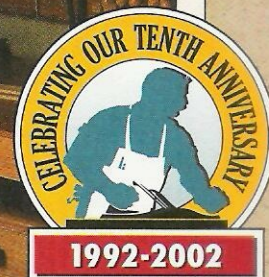

ALL-NEW
Table Saw
Workstation
HAS IT ALL

- **Lots of Storage**
- **Outfeed Support**
- **Space-Saving Design**
- **Built-in Router Table**



ShopNotes®

Issue 66

November 2002

PUBLISHER Donald B. Peschke
EDITOR Terry J. Strohmman
ASSOCIATE EDITORS Bryan Nelson
 Vincent Ancona
CONTRIBUTING EDITOR Phil Huber
ART DIRECTOR Cary Christensen
SR. GRAPHIC DESIGNER Kurt Schultz
SENIOR ILLUSTRATORS Roger Reiland
 Mark Higdon

CREATIVE RESOURCES

Creative Director: Ted Kralicek • *Sr. Project Designers:* Ken Munkel, Kent Welsh, Ryan Mimick, Chris Fitch • *Shop Craftsmen:* Steve Curtis, Steve Johnson • *Sr. Photographer:* Crayola England

SPECIAL PUBLICATIONS

Corp. VP: Douglas L. Hicks • *Art Director:* Douglas A. Flint • *Sr. Graphic Designer:* Chris Glowacki • *Graphic Designers:* Vu Nguyen, Jonathan Eike • *Senior Editor:* Craig Rueggsegger • *Asst. Editor:* Joel A. Hess • *Editorial Intern:* Cindy Thurmond

CIRCULATION

Subscriber Services Director: Sandy Baum • *New Business Dir.:* Wayne J. Klingbeil • *Circulation Marketing Analysts:* Kris Schlemmer, Paula M. DeMatteis • *Renewal Manager:* Paige Rogers • *Sr. Graphic Designers:* Mark Hayes, Robin Friend • *Billing & Collections Mgr.:* Rebecca Cunningham • *Multimedia Promotion Mgr.:* RickJunkins • *Promotion Analyst:* Patrick Walsh

CORPORATE SERVICES

V.P. of Finance: Mary R. Scheve • *Controller:* Robin K. Hutchinson • *Sr. Acct.:* Laura J. Thomas • *Accts. Payable:* Mary J. Schultz • *Accts. Receivable:* Margo Petrus • *Prod. Dir.:* George Chmielarz • *Electronic Pub. Dir.:* Douglas M. Lidster • *System Admin.:* Cris Schwanebeck • *P.C. Maint. Tech.:* Robert D. Cook • *Pre-Press Image Specialists:* Troy Clark, Minnette Johnson • *New Media Mgr.:* Gordon C. Gaippe • *Multimedia Art Dir.:* Eugene Pedersen • *Web Server Admin.:* Carol Schoeppler • *Web Content Mgrs.:* David Briggs, Sue M. Moe • *Web Designer:* Kara Blessing • *Prof. Dev. Dir.:* Michal Sigel • *H. R. Asst.:* Kirsten Koele • *Office Mgr.:* Natalie Lonsdale • *Facilities Mgr.:* Kurt Johnson • *Receptionist:* Jeanne Johnson • *Mail Room Clerk:* Lou Webber

MAIL ORDER

Operations Director: Bob Baker • *Customer Service Mgr.:* Jennie Enos • *Warehouse Supr.:* Nancy Johnson • *Buyer:* Linda Jones • *Admin. Asst.:* Nancy Downey • *Tech. Rep.:* John Audette • *Sr. Cust. Serv. Reps.:* Tammy Truckenbrod, Anna Cox, Deborah Rich, April Revell • *Cust. Serv. Reps.:* Valerie Jo Riley, Kim Harkan • *Warehouse:* Sylvia Carey

WOODSMITH STORE

Manager: Dave Larson • *Asst. Mgr.:* Tim Thelen • *Sales Staff:* Wendell Stone, Larry Morrison, Gregory Kauzlarich, Mark Johnson, Brian McCallum • *Office Mgr.:* Vicki Edwards

ShopNotes® (ISSN 1062-9696) is published bimonthly (Jan., March, May, July, Sept., Nov.) by August Home Publishing, 2200 Grand, Des Moines, IA 50312.

ShopNotes® is a registered trademark of August Home Publishing © Copyright 2002 by August Home Publishing. All rights reserved. **Subscriptions:** Single copy: \$4.95. One year subscription (6 issues), \$27.95. Canada/International add \$10 per year, U.S. funds. **Periodicals Postage Paid** at Des Moines, IA and at additional mailing offices.

Postmaster: Send change of address to ShopNotes, P.O. Box 37103, Boone, IA 50037-2103.

Subscription Questions? Write to: ShopNotes Customer Service, P.O. Box 842, Des Moines, IA 50304-9961. Or call 1-800-333-5854, 8:00 am to 5:00 pm, Central Time, weekdays. FAX 515-283-0447

Email: ShopNotes@shopnotes.com

Internet: http://www.shopnotes.com

PRINTED IN U.S.A.

EDITOR'S NOTE

Cutoffs

Last issue we featured a full-size workbench. At the time I mentioned that we would be featuring a storage system to go with it.

Of course, I wanted a place to store lots of woodworking tools. And I wanted to keep them organized and close at hand. My first thought was to simply custom fit a large cabinet under our workbench.

But the more I thought about it, I realized that this solution wouldn't be very versatile. After all, you may already have a workbench that's a different size than ours. And what about the woodworkers who prefer not to store tools under their bench at all?

The solution to this big storage problem was to think smaller. Instead of one large cabinet, we designed two smaller ones. This way, you can set the cabinets side-by-side under your bench, or you can stack them up for convenient roll-around storage. Either way, I think it's a versatile storage system that "stands" on its own.

Saw Station – We used a similar approach to another project in this issue — the Table Saw Workstation on page 20. The initial idea was to

make a stand for a portable table saw that would provide storage and outfeed support for ripping long pieces.

Here again, we started with the concept of one large cabinet, but realized it would be more versatile if we split the project into two parts. Not to mention the fact that a large cabinet might defeat the main reason for having a smaller saw in the first place — floor space.

Now you can start by building a small base cabinet. This cabinet puts the saw at a good working height, takes up little floor space, and provides plenty of storage.

Then if you want more capability (and have the room), you can add another cabinet. It provides all the outfeed support you could ask for. And to make better use of the space it takes up, we incorporated a router table and a handy place to store a shop vacuum for collecting dust.

I guess it just goes to show you that "bigger" isn't necessarily better. Sometimes the best solutions come about when you think "small."

Terry

STATEMENT OF OWNERSHIP, MANAGEMENT, AND CIRCULATION (Required by 39 U.S.C. 3685)

1. Publication Title: ShopNotes. 2. Publication No.: 1062-9696. 3. Filing Date: September 15, 2002. 4. Issue Frequency: Bimonthly. 5. No. of issues published annually: 6 (six). 6. Annual subscription price: \$27.95. 7. Complete mailing address of known office of publication: 2200 Grand Avenue, Des Moines, (Polk County), Iowa 50312-5306. 8. Complete mailing address of the headquarters or general business offices of the publisher: 2200 Grand Avenue, Des Moines, (Polk County), Iowa 50312-5306. 9. Full names and complete mailing addresses of publisher, editor, and managing editor: Publisher: Donald B. Peschke, 2200 Grand Avenue, Des Moines, Iowa 50312; Editor: Terry Strohmman, 2200 Grand Avenue, Des Moines, Iowa 50312. 10. Owner: August Home Publishing Company, 2200 Grand Avenue, Des Moines, Iowa 50312; Donald B. Peschke, 2200 Grand Avenue, Des Moines, Iowa 50312. 11. Known bondholders, mortgagees, and other security holders owning 1 percent or more of total amount of bonds, mortgages or other securities: None. 12. (Does not apply.) 13. Publication Title: ShopNotes. 14. Issue Date for Circulation Data Below: July/August 2002 (#64). 15. Extent and nature of circulation:

	Average no. copies each issue during preceding 12 months	Average no. copies of single issue published nearest to filing date
A. Total number of copies (net press run).....	219,575	196,880
B. Paid and/or requested circulation:		
1. Paid/Requested outside-county mail subscriptions stated on Form 3541.....	170,559	151,947
2. Paid in-county subscriptions.....	0	0
3. Sales through dealers and carriers, street vendors, counter sales, and other non-USPS paid distribution.....	21,697	23,068
4. Other classes mailed through the USPS.....	0	0
C. Total paid and/or requested circulation.....	192,256	175,015
D. Free distribution by mail, samples, complimentary, and other free copies:		
1. Outside-county as stated on Form 3541.....	120	121
2. In-county as stated on Form 3541.....	0	0
3. Other classes mailed through the USPS.....	0	0
E. Free distribution outside the mail (carriers or other means).....	0	0
F. Total free distribution.....	120	121
G. Total distribution.....	192,376	175,136
H. Copies not distributed.....	27,199	21,744
I. Total.....	219,575	196,880
J. Percentage Paid and/or requested circulation.....	99.94%	99.93%
16. Publication of Statement of Ownership. Will be printed in the Nov./Dec. 2002 (#66) issue of this publication.		
17. I certify that all information furnished on this form is true and complete. (Signed) Terry Strohmman, Editor		

On occasion, we allow companies whose products and services may be of interest to you to send advertising mail to our subscribers. We are careful to choose ethical companies that have information of genuine interest to our subscribers. Most of our subscribers appreciate receiving these materials. However, if you prefer to have your name deleted from the mailing list made available to other companies, please write to us at ShopNotes, 2200 Grand Avenue, Des Moines, IA 50312

Contents

Features

Thin-Stock Hold-Down _____ 6

Need to cut thin veneer or laminate on the table saw? You'll get chip-free results safely with our shop-made hold-down, whether you're cutting narrow strips or wide ones.

Convertible Shop Storage Cabinets ____ 10

It's easy to see how much storage you can pack into these handy cabinets. What you can't see is how versatile they are. You can stack them, like you see in the photo at right, or set them side-by-side under a bench.

Tongue & Groove Joinery _____ 18

Solid, dependable, and easy to make — tongue and groove joinery gets high marks for all three. We show you how to cut this basic joint on the table saw, providing tips and techniques for getting great results every time.

Table Saw Workstation _____ 20

Any shop can benefit by combining tools in a central location. Our two-cabinet workstation features a portable table saw, table-mounted router and fence, and a shop vacuum — along with a pair of drawers for storing all your accessories.

6-Step Router Plate Installation _____ 30

Fitting a router plate into the top of a table doesn't have to be a hassle. We'll show you step-by-step how to do this successfully using a hand-held router and a set of shop-made guides.

Departments

Readers' Tips _____ 4

Shop-tested tips to solve common woodworking problems.

Tool Chest _____ 32

Sometimes the smallest tool packs the biggest punch. This issue's tool slips easily in the pocket of your apron so it's always close at hand when you need it.

Shop Talk _____ 34

See how something as simple as the grain of a workpiece can dramatically affect the look of a project.

Sources _____ 35

Mail-order sources and supplies to help you complete the projects featured in this issue.

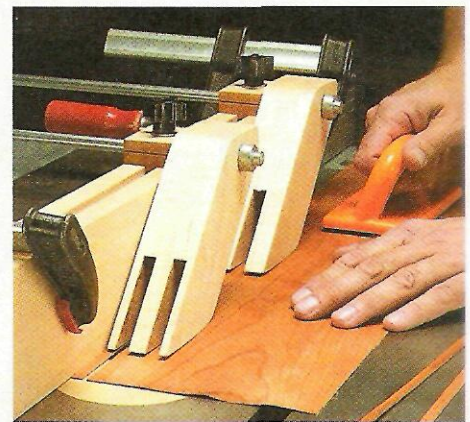

Thin-Stock Hold-Down page 6



Shop Cabinets page 10

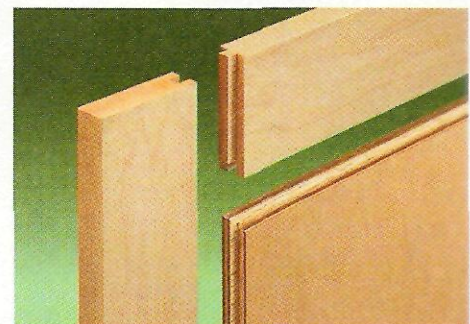

Tongue & Groove page 18

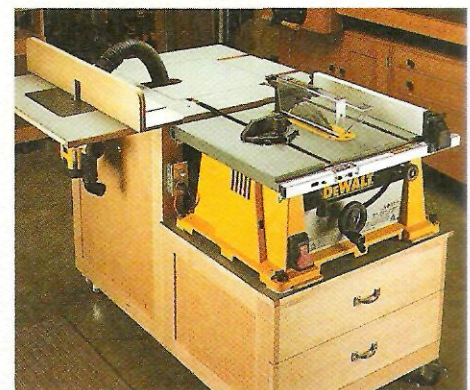
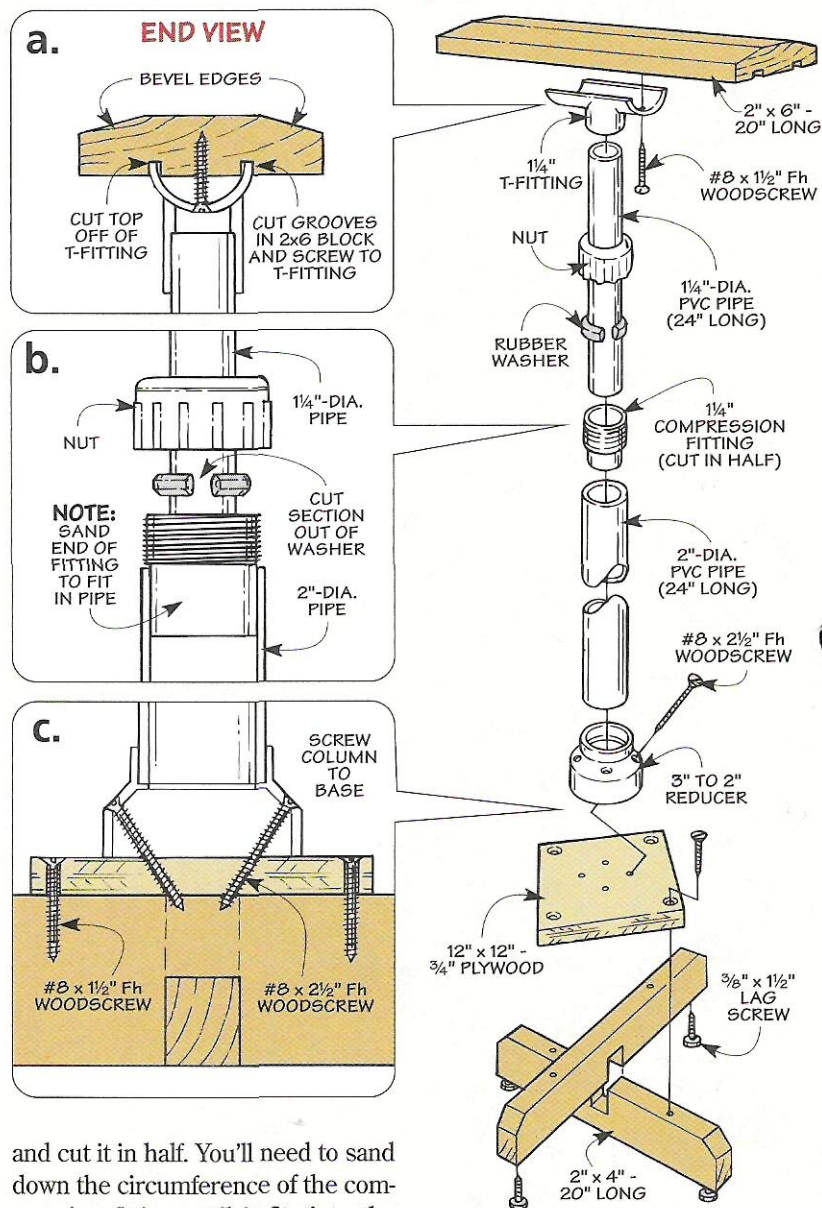
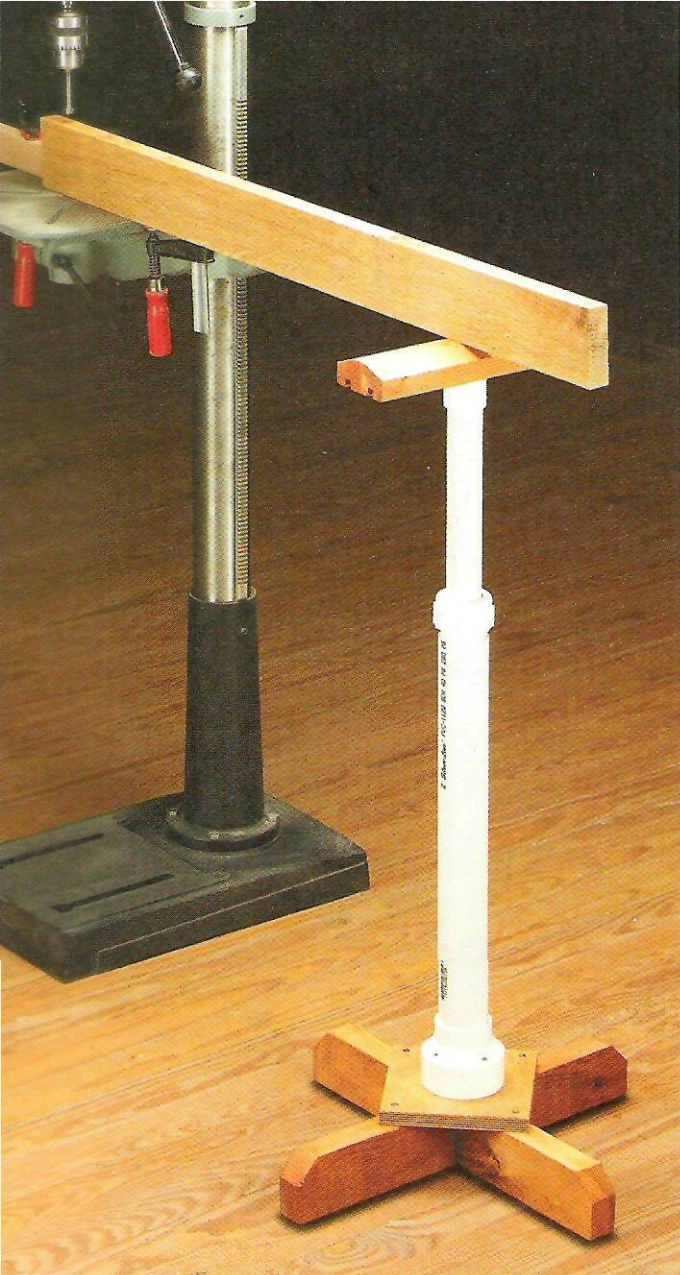

Table Saw Workstation page 20

Readers' Tips

PVC Outfeed Support



■ Whenever I'm working with long pieces, I often have a hard time supporting the end of the workpiece. So I came up with this adjustable-height work support stand. The nice thing about this stand is that it can be built in about an hour for around \$20 in materials.

The stand is primarily made out of standard PVC pipe and fittings. Two different diameters of pipe are used for the column of the stand. A PVC compression fitting joins the two sections of the column and allows you to adjust the height of the stand, as shown above.

To make the lower half of the column, glue a reducer fitting onto the end of a section of 2" PVC pipe. Then take a 1/4" compression fitting

and cut it in half. You'll need to sand down the circumference of the compression fitting until it fits into the end of the 2" pipe. Then, glue the pieces together.

The riser section of the column is made out of 1/4" PVC pipe. To create a mounting surface for the top of the stand, the top is sliced off a T-fitting and the fitting is glued onto the end of the pipe, detail 'a'. Now just slip the nut and rubber washer from the compression fitting over the end of

the riser and then slip the riser into the column. (You'll have to cut a section out of the washer to allow it to fit around the riser, detail 'b'.)

Finally, I made a base and top for the stand out of a piece of 3/4" plywood and some "two-by" scraps.

*Charles E. Phelps
Pittsford, New York*

Free Tips

ON THE WEB

Get more wood-working tips free.

Visit us on the Web at ShopNotes.com

Sign up to receive a free shop tip by email every week.

Quick Tips

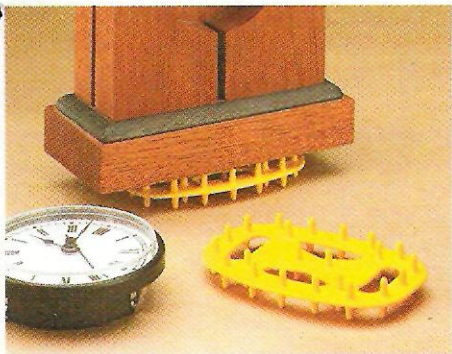

▲ **Dana Craig** of Norwood, MA uses plastic soap holders to support small projects during finishing. This prevents them from sticking to the top of his bench.

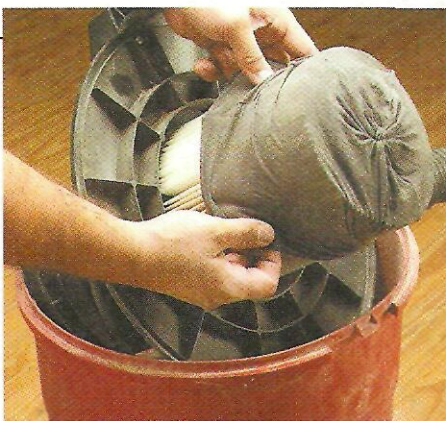

▲ **Duane Barnes** of Menomonie, WI slips a length of panty hose over the filter of his shop vacuum. The hose keeps sawdust from lodging in the pleats of the filter.



▲ **Charles Nielsen** of Forest Lake, MN makes a drying rack for molding and trim by hammering some nails into a pair of 2x4s and leaning them against the wall.

Spring Clamp Support

■ Whenever I use my jig saw to cut thin stock, I have trouble with the waste piece drooping down and pinching the saw blade. To help keep the waste side of the stock supported, I use a strong spring clamp. After starting the cut, I just position the spring clamp over the kerf on the end of the workpiece.

*Gary Rowe
Woodland Hills, California*

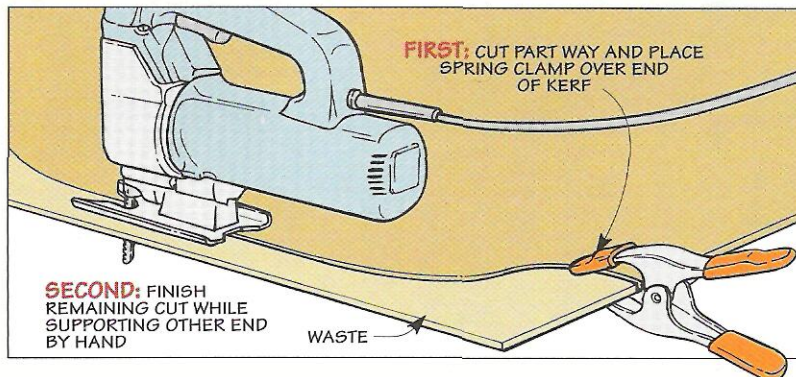

Quick Connect

■ When I was installing a dust collection system in my shop, I was a bit surprised by the high cost of the hose clamps. Fortunately, I found a cheaper solution. While browsing through a home improvement store, I came across some wire hose

clamps that are used for clothes dryer vents. The clamps were inexpensive and as you can see in the photo at left, they fit the hoses on my dust collection system perfectly. As

an added bonus, you don't need any tools to connect them — just squeeze the ends with your fingers.

*P. A. Jones
Gig Harbor, Washington*

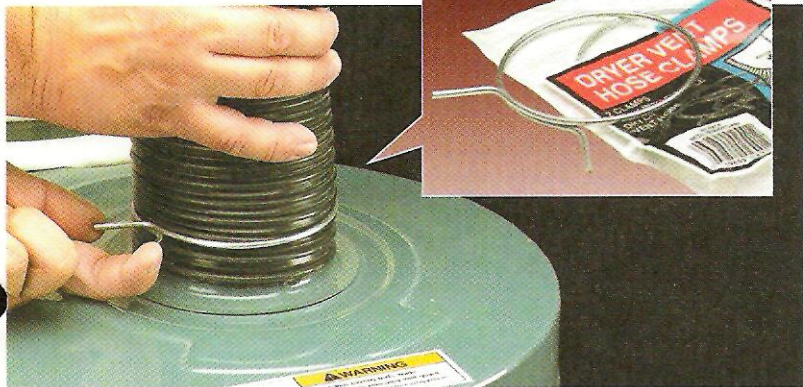

Send in Your Shop Tips

If you have a unique shop tip, we'd like to consider featuring it in one or more of our print or electronic publications.

We'll pay up to \$200 for a tip we publish. Just write down the tip and mail it to *ShopNotes*, Attn.: Readers' Tips, 2200 Grand Ave., Des Moines, IA 50312. Or FAX it to 515-282-6741, or send us an e-mail at shopnotes@shopnotes.com. Please include your name, address and daytime phone number in case we have any questions.

Thin-Stock Hold-Down



This jig lends a helping hand when cutting veneer, plastic laminates, or other thin stock.

Cutting thin stock like veneer and plastic laminate has always given me some trouble. The stock tends to “surf” over the blade, tearing and chipping as it goes. It also has a tendency to wedge itself under the fence, where it gets stuck. This jig solves both of those problems. Here’s how it does it.

How it Works – You can see from the photos on this page that the

jig is basically an auxiliary fence that clamps to your existing rip fence. The bottom edge of the fence is beveled so that it makes full contact with the table of the saw. This prevents thin material from working its way underneath the fence.

Connected to the fence by a pair of steel adjusting rods are a pair of hold-down blocks that act like another set of “hands” while cutting.

One of the hold-down blocks is positioned in front of the blade, so the workpiece is held on the table as you feed it into the blade. The rear block straddles the blade and prevents the stock from being lifted up.

The hold-down blocks can be adjusted in or out for different widths of material. So you can cut very thin strips (for inlays or for edging a countertop) or wider pieces.

At first glance, the hold-down blocks look a lot like featherboards. But there’s a difference. Featherboards are usually fixed rigidly in

place. The hold-down blocks on this fence dangle and pivot freely from the ends of a pair of steel rods. The weight of the blocks offers just enough pressure to keep the stock flat on the table without making it difficult to push the workpiece through the saw blade.

AUXILIARY FENCE

If you take a look at the exploded view to the right, you’ll see that there are two main assemblies to this jig — a simple auxiliary fence that clamps to your rip fence and a pair of hold-downs that ride in a T-slot on the top of the fence. I began by making the auxiliary fence.

Two-Piece Construction – As you can see in Figure 1, there are two pieces that make up the L-shaped auxiliary fence (A). A groove cut in each piece will form the T-slot. The first step is to cut the fence face piece to width. The height of the fence will depend on the height of your table saw’s rip fence. I made my fence 1" wider (taller) than the overall height of my rip fence. This will allow the bottom

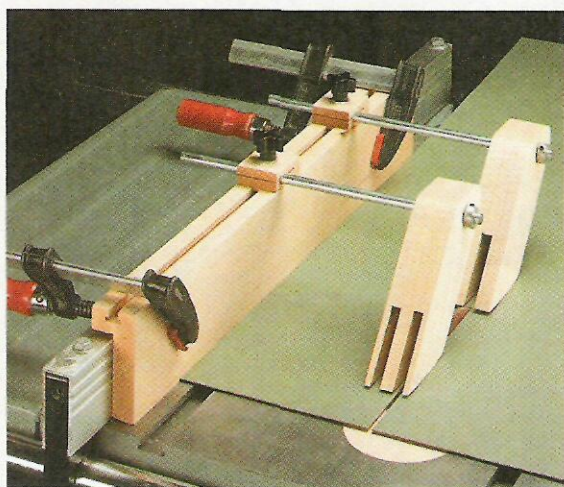

▲ **Wide or Narrow.** The adjustable hold-down blocks are mounted to rods that slide out, allowing you to cut laminate or veneer as wide as 8½".

EXPLODED VIEW

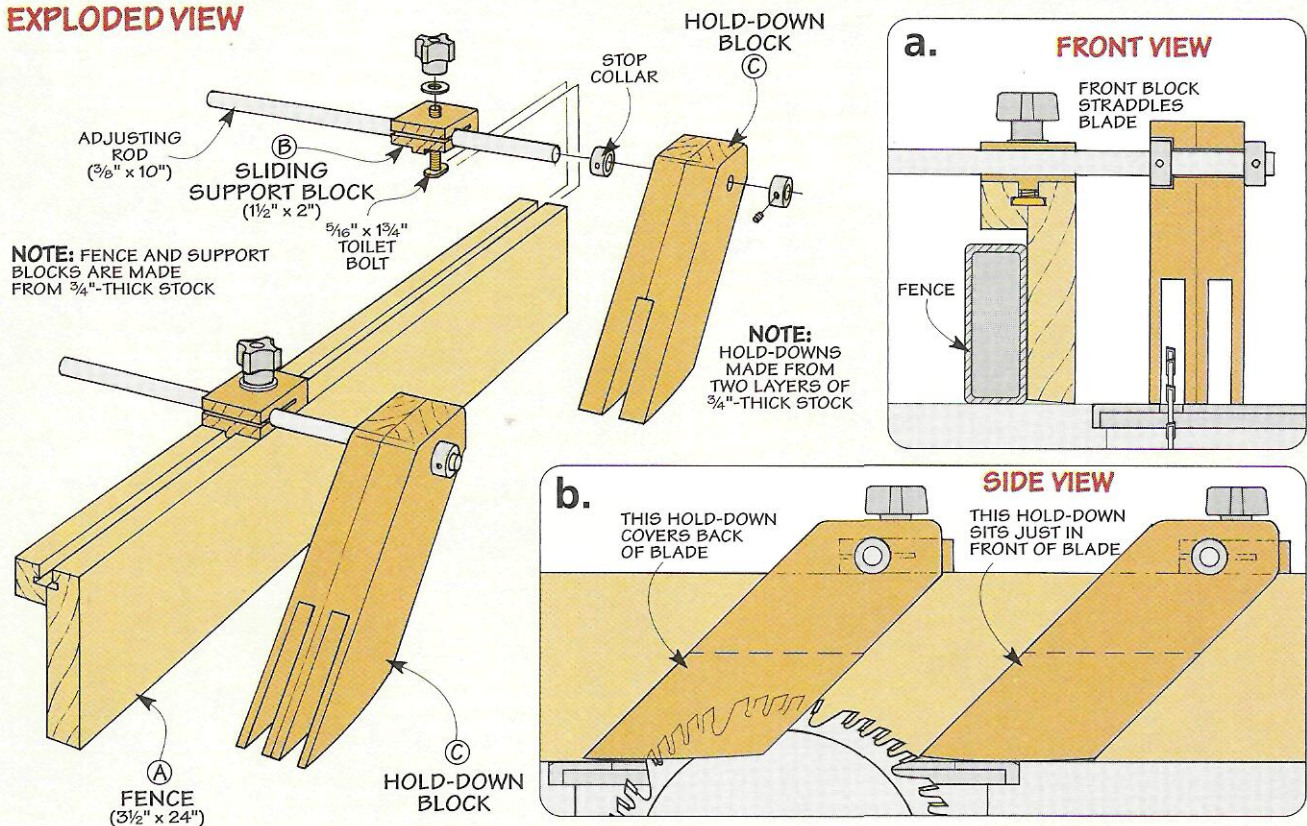

edge of the auxiliary fence to rest completely on the table of the saw.

I also added a slight bevel to the bottom of the fence face, like Figure 1a shows. This is to prevent your workpieces from getting wedged in between the fence and the saw table when using the jig.

The second part of the fence is just a narrow strip of 3/4" stock cut to the same length as the face of the fence. It will get glued to the face

piece of the fence, but not just yet. First, you'll need to make the T-slot.

Cutting the Slot – The T-slot on the top of the fence will allow you to adjust the hold-down blocks that are added later. Toilet bolts will slide in the T-slots and be used to lock the sliding support blocks and hold-down blocks in place.

Making the T-slot is actually a two-step process. First, a 1/8"-wide saw kerf is cut in both pieces of the fence,

as you see Figure 1b. When the two parts of the fence are glued together, these kerfs will form the bottom of the T-slot that will hold the heads of the toilet bolts. It will be opened after the pieces are glued together.

Once you've cut the kerfs, you can glue the two pieces together. The trick here is in keeping the saw kerfs for the T-slot aligned while clamping up the workpieces.

The solution is to use a "key." I just cut a narrow strip of 1/8" hardboard to fit in the kerfs. The key will keep the kerfs aligned while the glue dries. To avoid accidentally gluing the key in place, just give it a coat of wax so it can be removed once the glue dries, see the margin detail to the right.

With the fence glued up as one piece, you're ready to complete the T-slot. This is just a matter of cutting a slot along the top of the fence for the shank of the toilet bolts.

I did this by removing the waxed key and setting the fence upside down on the table saw. Then I cut the slot opening in a couple of passes, as shown in Figure 1c.

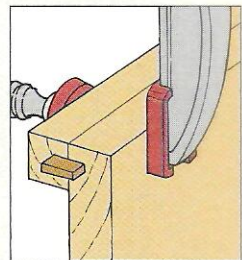

▲ **Waxed Key.** A waxed hardboard key helps to keep the kerfs aligned during glue up.

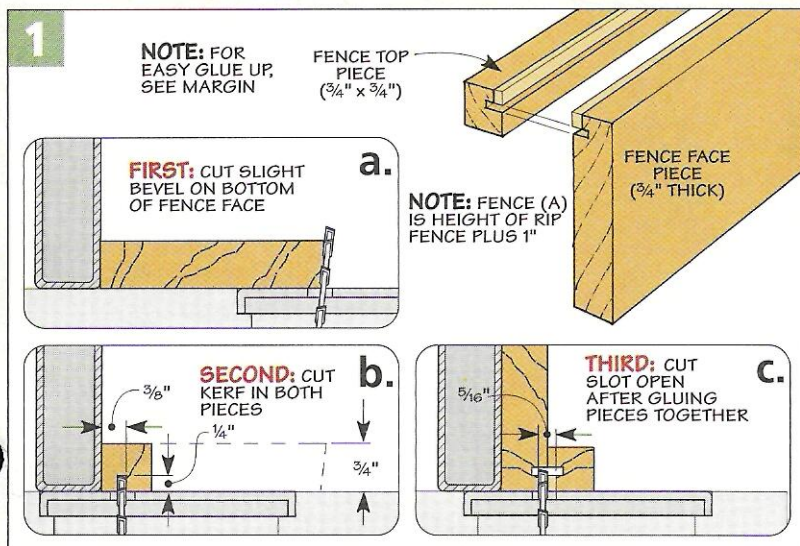

Hold-Down Assembly

With the fence completed, you're now ready to make the two adjustable hold-down assemblies for the jig, as in Figure 2.

There are two parts to each assembly. The first part is a sliding support block that rides in the fence T-slot. It positions the hold-down block along the auxiliary fence. It's held in place by a toilet bolt and knob, as you can see in Figure 2a.

The second part is the hold-down block. The weight and the shape of these blocks holds the workpiece on the table. The "fingers" of the blocks are designed to straddle the blade. They are connected to the sliding support blocks by a pair of steel rods, as shown in Figure 2b.

Support Blocks – I began by making the *sliding support blocks* (B). To make the pieces safer to work with, I did all the cutting and drilling on a single, extra-long blank before cutting the blocks to final size.

Start by ripping a 3/4"-thick blank to width. Next, you'll make a centered tongue sized to fit the slot on the fence by cutting two wide, shallow rabbets, like you see in Figures 3 and 3a.

With the tongue made, the next step is to drill holes for the toilet bolt and steel adjusting rod. To support the workpiece, clamp an auxiliary

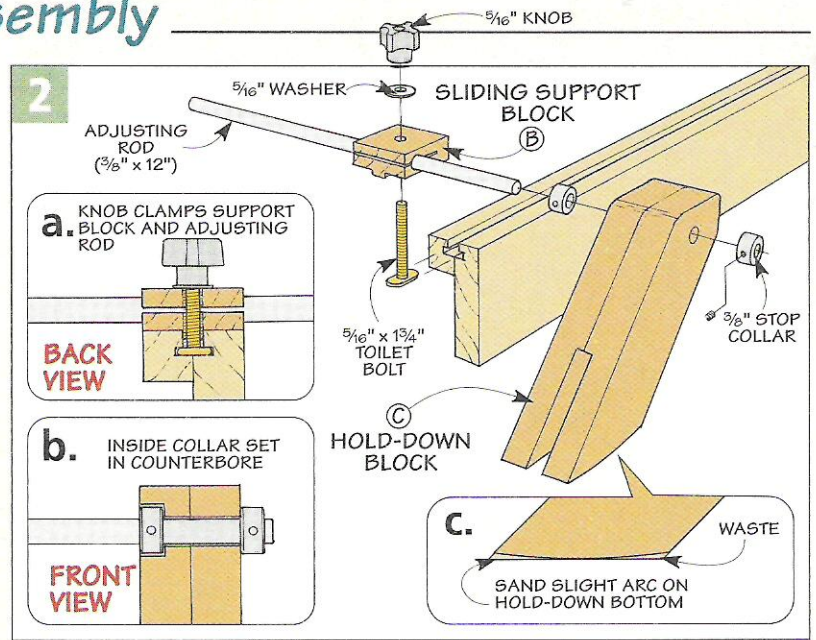
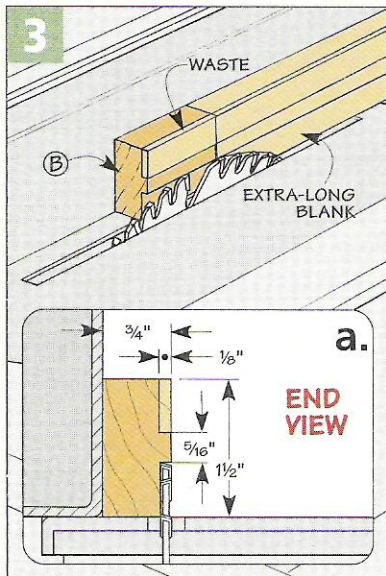

fence to the drill press, as in Figure 4. Then, you can drill the toilet bolt hole in the center of the block, as Figure 4a shows.

Next, center the bit on the thickness of the block and drill the hole for the steel rod, like in Figure 4b.

The last step before cutting the support blocks to length is to cut a kerf in the block. This allows the knob to pinch the adjusting rod and secure the sliding support block to the fence, see Figures 5 and 5a.

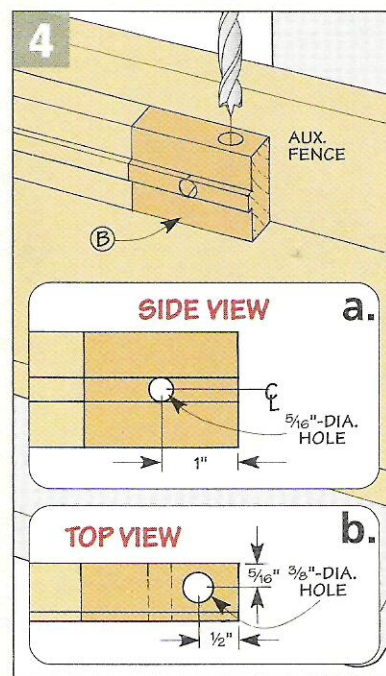

Then with the kerfs cut, you can cut the blocks to final length.

Hold-Down Blocks – The last parts of the jig to be made are the *hold-down blocks* (C). Just as their name implies, these blocks keep the material firmly on the saw table. They are made from two layers of 3/4"-thick stock, giving them just enough weight to hold the workpiece down. I found it easiest to glue up an extra-long blank before cutting them to their final size.

Once the glue has dried, you can cut out the hold-down blocks on the table saw. Since all cuts are 45°, I laid

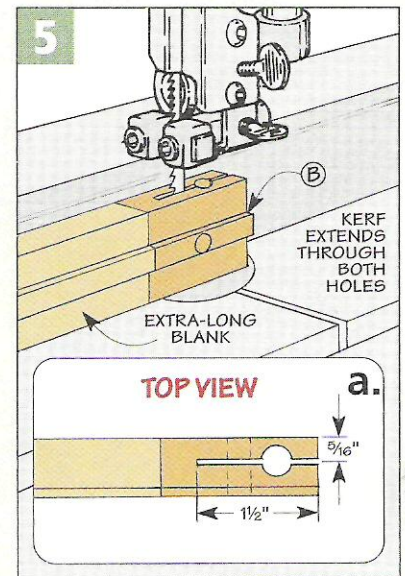

out the shape on the workpiece, then cut it to size. And to support the blank as the blocks are cut, I attached an auxiliary fence to the miter gauge, as in Figure 6.

Fingers – Now that the blocks are cut to their final shape, the next step is to cut the “fingers.” As you can see in Figures 7a and 7b, the fingers in each block are different. The rear block has an extra finger that forms a second slot that is used when cutting very narrow pieces.

Cutting the slots is the trickiest part of making the blocks. But I built a simple carriage to cut the slots safely. It’s a piece of hardboard glued and screwed to a 2x4 backing piece that’s been mitered at 45°.

The blocks are simply clamped into the jig, as Figure 7 shows. I cut the slots in several passes with a regular blade in the table saw, making sure the jig and block were held firmly against the fence.

Once the fingers are cut, I softened the sharp edges and sanded a slight radius on the bottom of the blocks to provide a smooth contact point regardless of the thickness of the workpiece, as in Figure 2c.

The jig is almost ready to put together. But first you’ll need to add a counterbored recess to the blocks for a stop collar and a through hole for a steel rod (Figure 6a). Finally, cut two steel adjusting rods to con-

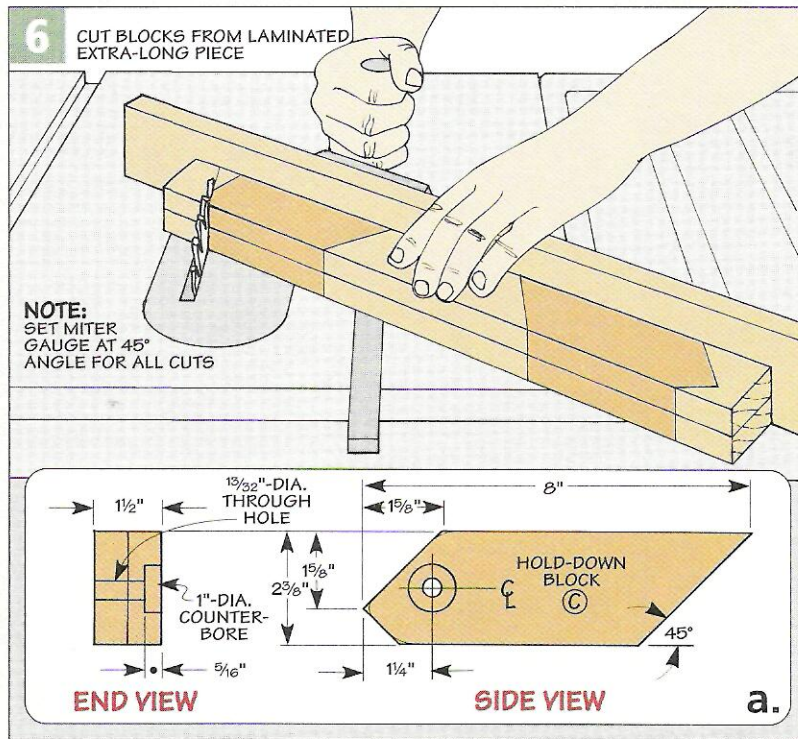

nect the hold-down blocks to the sliding support blocks and file off any sharp edges.

Setup and Use – At this point, you’re ready to assemble the parts and start cutting. The jig goes together pretty quickly. Begin by securing the toilet bolts and support blocks to the fence with washers and knobs. Next I attached the hold-down blocks to the steel rods with stop collars and slipped them through the sliding support blocks.

Now that it’s assembled, the jig is pretty easy to use. After clamping it to the fence, set the hold-down blocks to width. Next, position the rear block over the back half of the blade and the front block just in front of it and tighten the knobs.

One more thing. It’s a good idea to install a zero-clearance insert to provide support and prevent chipout. Then to safely clear narrow strips simply turn off the saw before pulling them out from the back.



▲ **Stop Collars.** A pair of stop collars position the hold-down blocks but still allow them to pivot.

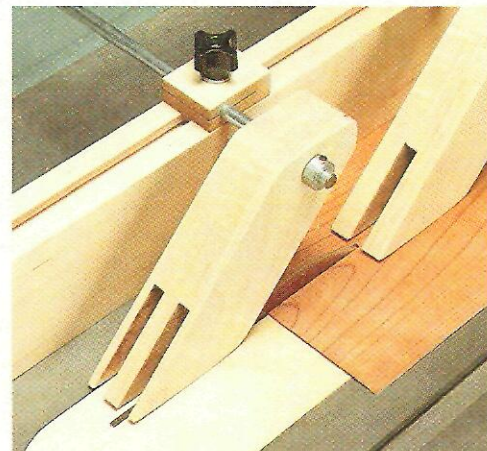
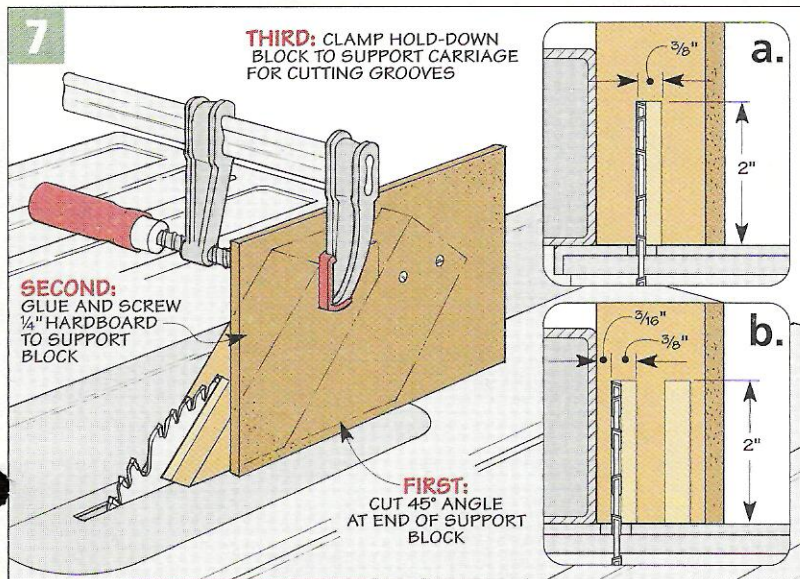

▲ **Added Control.** Using this jig with a zero-clearance insert on your table saw will give you greater control and accuracy when cutting thin laminates and veneers.



Convertible Shop Storage Cabinets

Upright or side-by-side? No, I'm not talking about refrigerator-freezers. I'm talking about our newest shop storage cabinet. Actually, it's two cabinets. One has drawers, and the other has doors. But the interesting thing about them is that they are designed so you can stack them up or set them side-by-side.

The idea came about while building the workbench in the last issue of *ShopNotes*. We wanted a storage cabinet to fit underneath the bench (see photo on page 17). But we realized that by making the cabinet in two separate sections, it would be easy to transform it into a stacked, roll-around tool chest, like the one you see above.

Whether you decide to build the side-by-side cabinet

or the "upright" version, the goal is the same — turning an unused area into valuable storage space. The compartment behind the doors is perfect for routers or other small power tools, while the drawers will hold most of your commonly used hand tools. And since they're mounted on full-extension slides, you can open each drawer all the way to reach items at the back.

Although we sized these storage units to fit underneath the workbench in issue No. 65, it would be easy to change the dimensions to suit a workbench that you already have. And while we used oak and oak plywood to match the bench, if you are building the units as a stand-alone cabinet, you can use any type of wood you like.

EXPLODED VIEW
OVERALL DIMENSIONS:
 32³/₄"W x 22³/₈"D x 40¹/₂"H

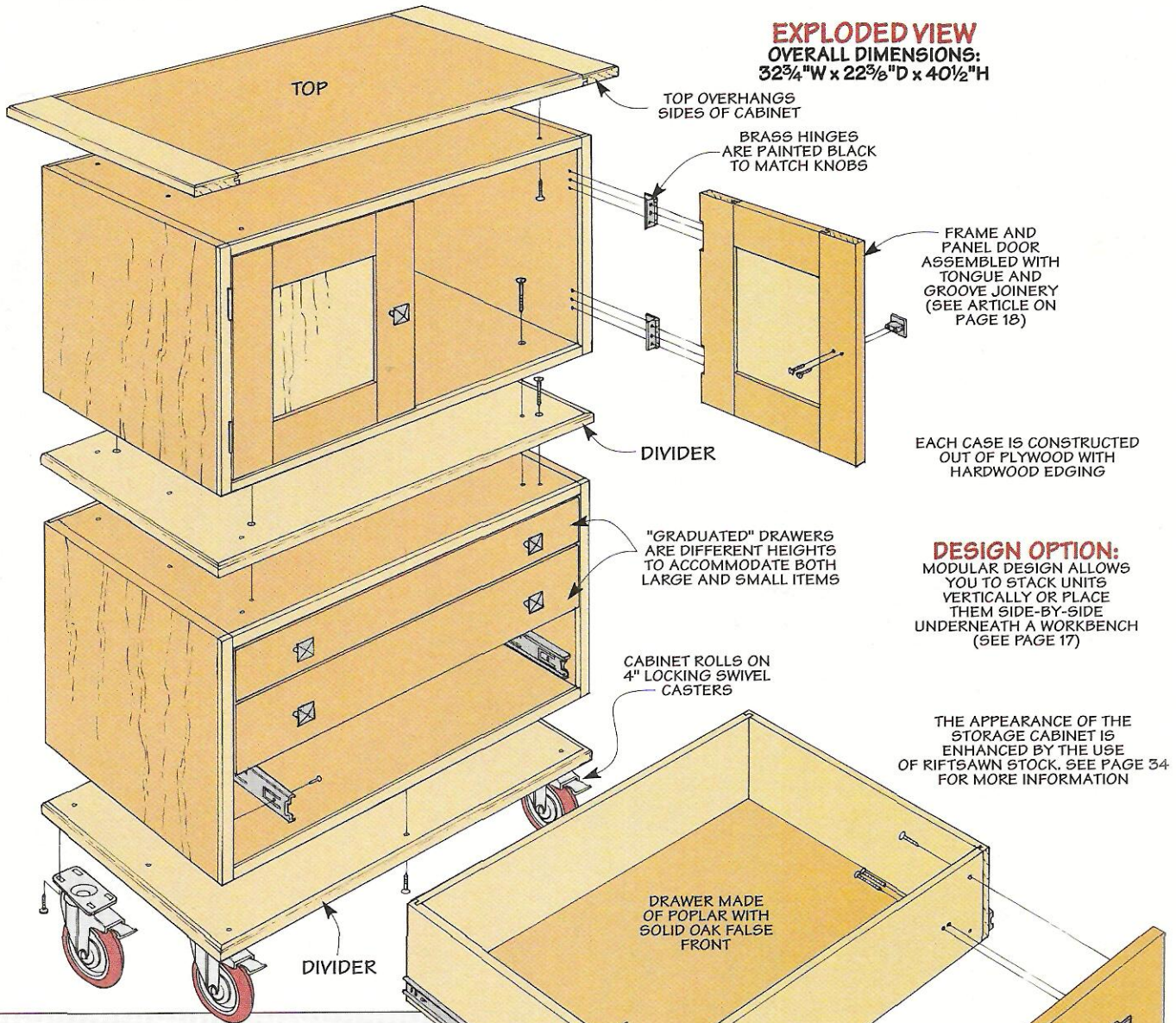

DESIGN OPTION:
 MODULAR DESIGN ALLOWS YOU TO STACK UNITS VERTICALLY OR PLACE THEM SIDE-BY-SIDE UNDERNEATH A WORKBENCH (SEE PAGE 17)

THE APPEARANCE OF THE STORAGE CABINET IS ENHANCED BY THE USE OF RIFTSAWN STOCK. SEE PAGE 34 FOR MORE INFORMATION

Materials

A Case Tops/Bottoms (4)	20 ³ / ₄ x 28 - ³ / ₄ Plywood
B Case Sides (4)	21 x 16 ¹ / ₂ - ³ / ₄ Plywood
C Edging (1)	³ / ₈ x ³ / ₄ - 40 lin. ft.
D Case Backs (2)	28 ¹ / ₄ x 16 ¹ / ₂ - ¹ / ₄ Plywood
E Door Rails (4)	³ / ₄ x 3 - 8 ¹ / ₄
F Door Stiles (4)	³ / ₄ x 3 - 14 ⁷ / ₈
G Door Panels (2)	8 ¹ / ₄ x 9 ⁵ / ₈ - ¹ / ₄ Plywood
H Sm. Drawer Fronts/Backs (2)	¹ / ₂ x 3 ¹ / ₄ - 25 ³ / ₄
I Med. Drawer Fronts/Backs (2)	¹ / ₂ x 4 ¹ / ₂ - 25 ³ / ₄
J Lg. Drawer Fronts/Backs (2)	¹ / ₂ x 6 ¹ / ₄ - 25 ³ / ₄
K Sm. Drawer Sides (2)	¹ / ₂ x 3 ¹ / ₄ - 20
L Med. Drawer Sides (2)	¹ / ₂ x 4 ¹ / ₂ - 20
M Lg. Drawer Sides (2)	¹ / ₂ x 6 ¹ / ₄ - 20
N Drawer Bottoms (3)	19 ¹ / ₂ x 25 ³ / ₄ - ¹ / ₄ Plywood
O Sm. Drawer False Front (1)	³ / ₄ x 3 ¹ / ₂ - 27 ¹ / ₈
P Med. Drawer False Front (1)	³ / ₄ x 4 ³ / ₄ - 27 ¹ / ₈
Q Lg. Drawer False Front (1)	³ / ₄ x 6 ¹ / ₂ - 27 ¹ / ₈
R Base/Divider Panels (2)	21 ¹ / ₄ x 28 ¹ / ₂ - ³ / ₄ Plywood
S Top Panel (1)	21 ⁵ / ₈ x 27 ¹ / ₂ - ³ / ₄ Plywood
T Top Ends (2)	³ / ₄ x 3 - 22 ³ / ₈

Case

As I mentioned earlier, this storage cabinet is made up of two separate units. Although we built one unit with drawers and the other with doors, you can build them any way you choose (both with drawers or both with doors). The real beauty of this design is the fact that the cases of both units are identical no matter how you configure them. Essentially, each case is nothing more than an open plywood box.

Cut Case Pieces to Size – You can start by cutting out the plywood pieces for the *case tops* and *bottoms* (A), and the *case sides* (B). As you can see in Figure 1, these pieces are joined together with tongue and dado construction. Tongues cut on the ends of the top and bottom fit into dadoes cut into the sides. Figure 1a shows a detail of this joint.

Once you've finished cutting all the tongue and groove joints, you can set the top and bottom aside until you're ready for assembly. But there is still just a little more work to do on the case sides.

First, you'll need to cut a rabbet along the back edge of each side piece. You can see this rabbet in Figure 1b above. This rabbet will hold a back panel that is added later. (The top and bottom of the case will simply butt up against the back, so they don't need to be rabbeted.)

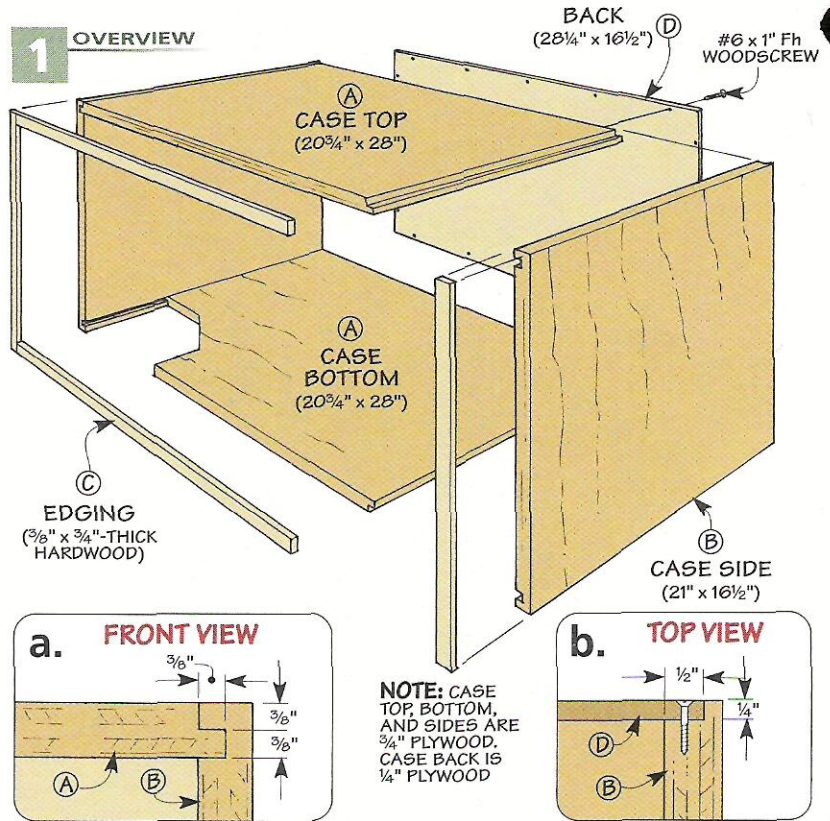

Edging – To conceal the plywood edges of the case, I added some hardwood *edging* (C) to the front edge of each side piece. Then I trimmed the edging flush on the router table. If you look at Figure 2 below, you'll see that I did this using a flush trim bit to support the workpiece and act as a bearing surface.

Assembly – Before you assemble the case, take a look at the front of the grooves in the case sides. If there is any dried glue in the grooves just behind the edging, clean it out with a narrow chisel. If you don't, the tongues on the top and bottom panels won't seat tightly against the back of the edging when you assemble the case.

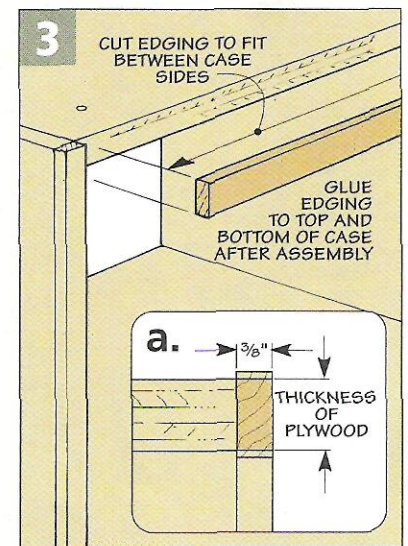
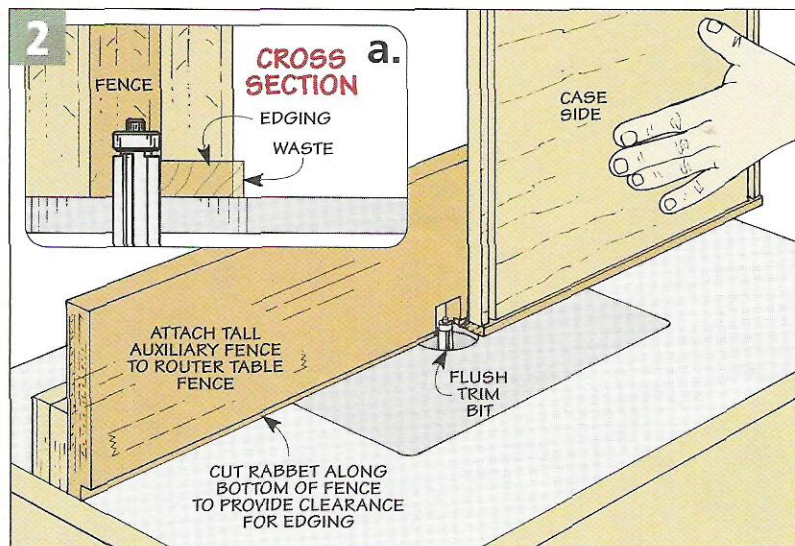

After you've assembled the case, you can add the edging to the front edges of the case top and bottom. Like the edging on the sides of the case, this edging also starts off a little wide. However, it is cut to exact length to fit in between the edging on the sides (Figure 3).

Once the glue is dry, you can trim the edging flush. But this time, you'll need to use a hand-held router. But because it can be hard to balance the router on the narrow front edge of the case, I clamped a support strip to the case, as shown in Figure 4. This support strip is actually glued up from two strips of wood — a wide one and a narrow one — to create a clearance gap for the router bit (Figure 4c).

With this support strip clamped in place, you can trim the edging on both the outside and inside of the case (Figures 4b and 4c). Just make sure to pay attention to the direction you are routing in order to avoid backrouting the workpiece.

The router bit won't be able to reach into the inside corners of the case. Here, you'll have to use a chisel to pare away the remaining waste, as

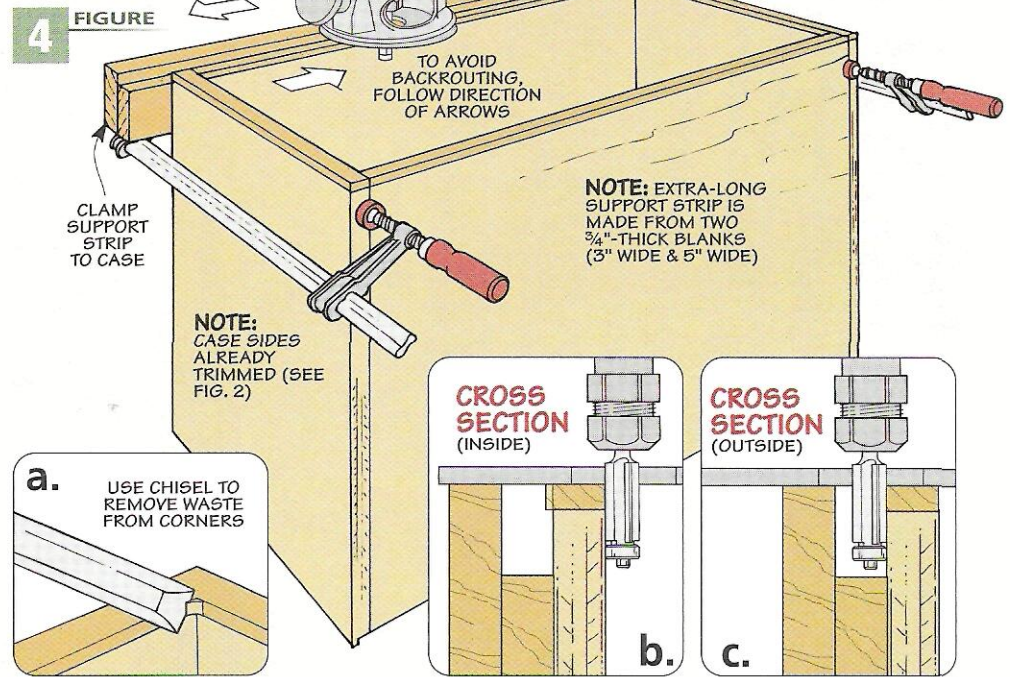

you see being done in Figure 4a.

Back – The last step to complete the cases is to add the backs. Each back (D) is cut from 1/4" plywood. If you take a look at Figure 5, you can see that the back is cut to fit in the rabbets in the sides of the case and is flush with the top (and bottom). Then it's simply screwed in place.

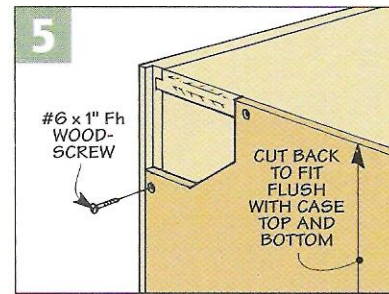

Cutting Diagram

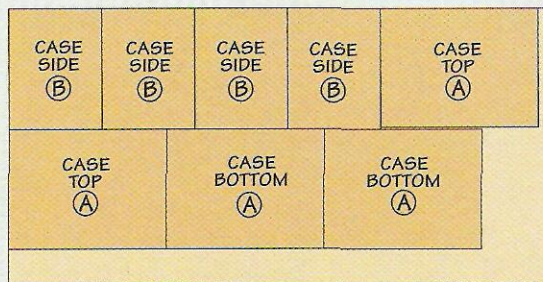

3/4" - 48" x 96" RIFTSAWN RED OAK PLYWOOD

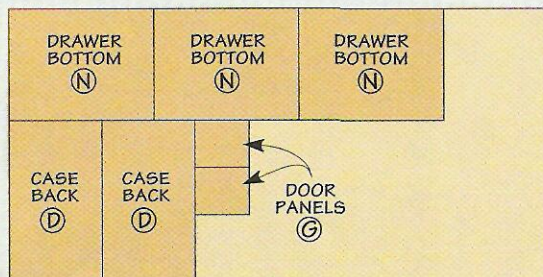

1/4" - 48" x 96" RIFTSAWN RED OAK PLYWOOD

Hardware

- (44) #6 x 1" Fh Woodscrews
- (4) 2" x 1 3/8" Brass Butt Hinges w/screws
- (2) Magnetic Catches w/screws
- (8) 1" Square Knobs
- (16) 8-32 x 1/4" Rh Machine Screws
- (3 pr.) 20" Drawer Slides w/screws
- (24) #8 x 1 1/4" Fh Woodscrews
- (4) #8 x 2" Fh Woodscrews
- (4) 4" Locking Swivel Casters
- (16) #14 x 5/8" Panhead Woodscrews
- (16) 1/4" Flat Washers

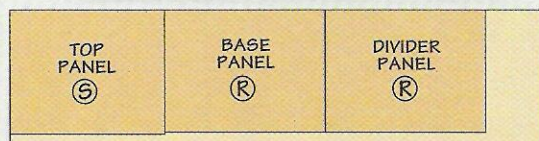

3/4" - 24" x 96" RIFTSAWN RED OAK PLYWOOD

Doors

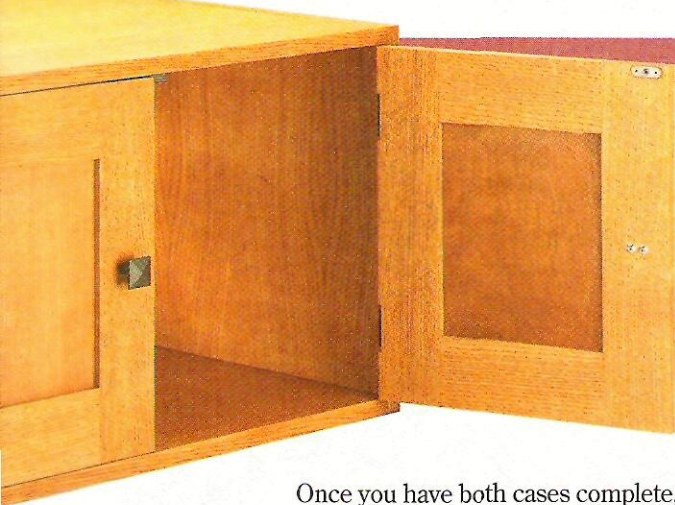

▲ **Open and Shut Case.** A pair of hinged doors open to reveal a large storage compartment.

Once you have both cases complete, you can turn your attention to making the doors and drawers that go inside them. It doesn't really matter which you choose to make first, but I started with the doors.

The doors are built with frame and panel construction. A hardwood frame surrounds a plywood panel. To build the doors, I started by cutting the door rails (E) and stiles (F) to size (Figure 6).

The door frames are assembled with tongue and groove joinery. (For a complete article on tongue and groove joinery, turn to page 18.)

The first step in making this joint is to cut a centered groove along the inside edge of each door piece. The width of this groove should be sized to match the thickness of the plywood you will be using for the door panels, Figure 7a. (I used 1/4" plywood for the panels, which was actually just over 3/16" thick.)



▲ **Color-Coordinated.** To match the black finish on the knobs, the hinges and screws are primed and then sprayed with black paint.

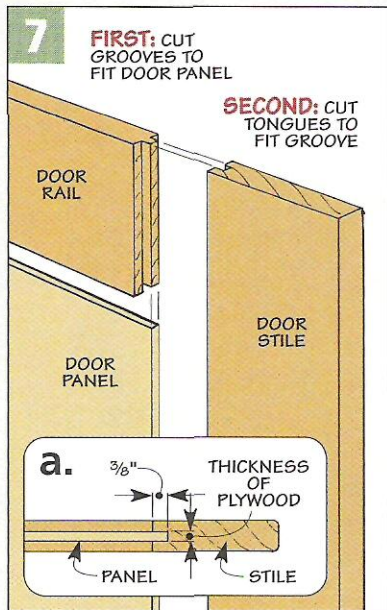
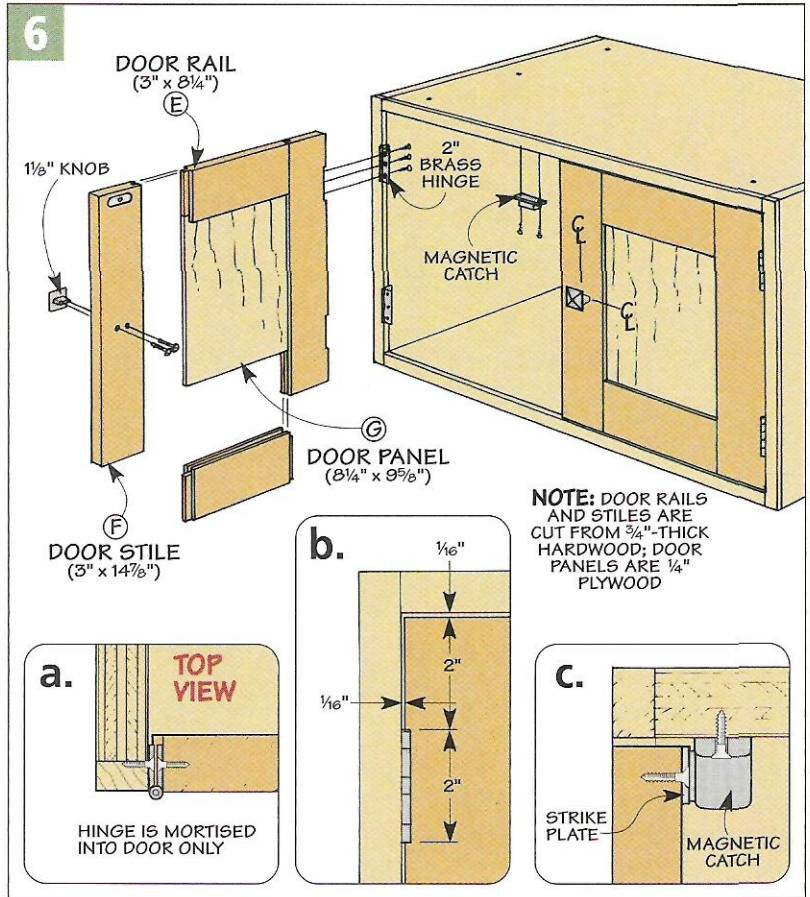

After cutting the grooves on the pieces, you can cut the tongues on the ends of the door rails. These tongues are 3/8" long and are sized to fit in the grooves cut in the stiles.

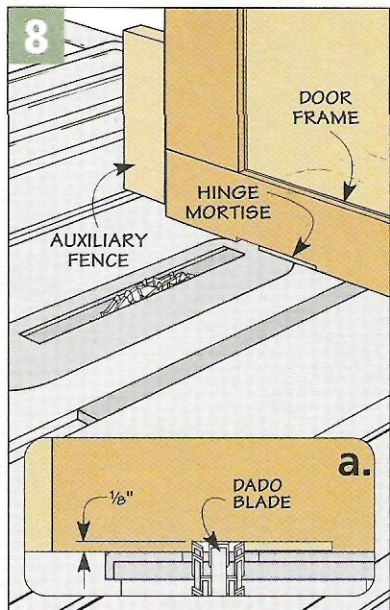

Panels - The door panels (G) are cut to size from 1/4" oak plywood. Once this is done, you can glue up each door frame around its panel.

Hardware - The last step to complete the doors is to mount them to the case and then add the rest of the hardware. Using the table saw, I cut a couple of mortises on the edge of each door for the hinges, as shown in Figures 8 and 8a. The hinges are mortised into the door only — they're surface mounted to the case.

There's one other thing to mention about the hinges. I wanted the hinges to match the black knobs that I planned to use. But all I could find were brass hinges. So I just spray-painted the hinges black before attaching them to the doors (see photo in margin at left).

Once the doors are in place, you can add a knob to each door and then install the magnetic catches, as shown in Figures 6 and 6c.

Drawers

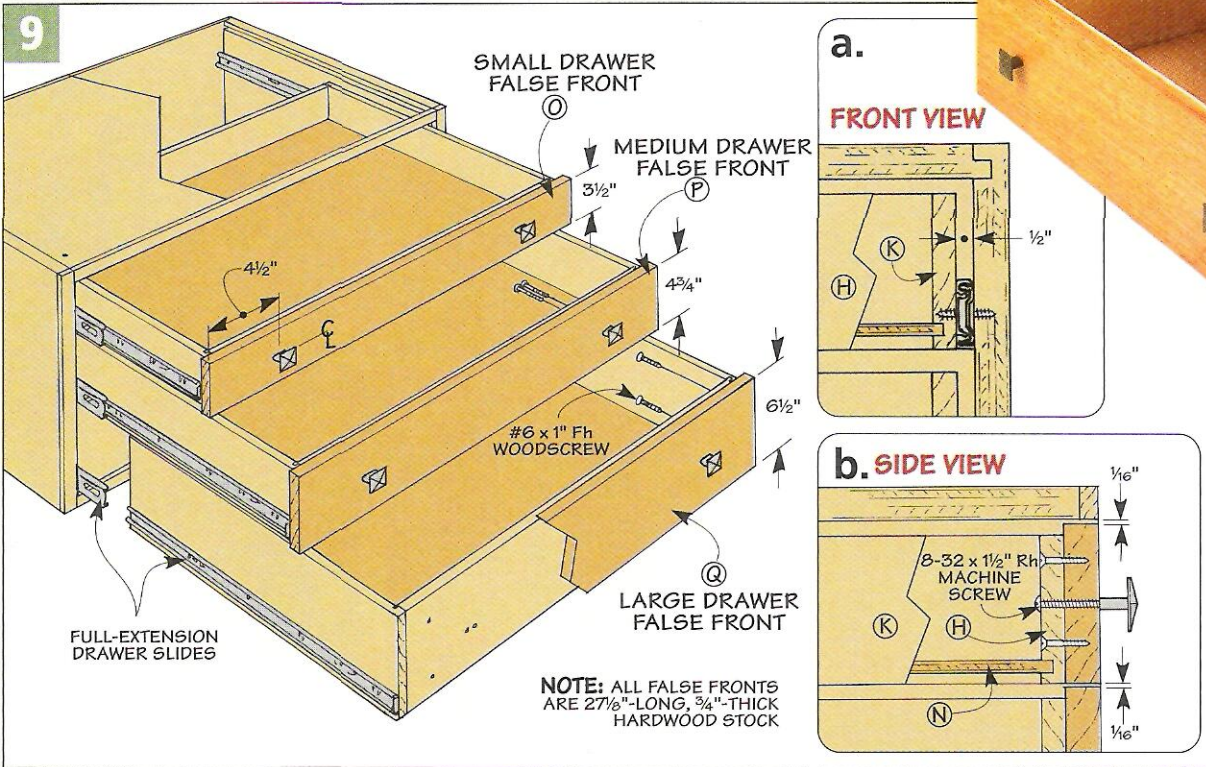

▲ **Easy Access.**
Full-extension metal drawer slides allow you to open each drawer all the way to reach items at the back.

Making the drawers for the storage cabinet is not difficult — but they are a little more time-consuming to build than the doors.

As you can see in Figure 9 above, there are three different sizes of drawers in the cabinet. Other than the height of each drawer, the construction is the same. All the drawers have false fronts and travel on full-extension, metal drawer slides.

To make the drawers, you can start by cutting the *fronts* and *backs* (H, I, J) and the *sides* (K, L, M) to size from 1/2"-thick hardwood stock, as in Figure 10. (I used poplar for the interior drawer parts.)

Next, you can cut the joinery on the drawer pieces. A narrow dado is cut near the ends of each drawer side. Then a tongue is cut on each end of the drawer fronts and backs to match the dadoses in the sides.

As shown in Figures 10 and 10a, the inside face of each drawer piece is grooved to hold a plywood bottom. (The width of this groove is sized to match the thickness of your ply-

wood.) Once this is done, you can cut three *bottoms* (N) to size from 1/4" plywood and glue up the drawers.

Drawer Slides — Each drawer is mounted on full-extension drawer slides. Each slide comes in two halves. One half mounts to the inside of the case, and the other mounts to the side of the drawer. Take a look at Figure 9a for the positioning of the drawer slides.

False Fronts — Once you have all three drawers mounted in the case, you can make the false fronts. Each *false front* (O, P, Q) is cut to size from 3/4"-thick hardwood. I sized the false fronts to leave a 1/16" gap on all four sides of each drawer.

The false fronts are simply screwed to the drawers (Figure 9b). Then you can add a couple of knobs to the front of each drawer.

10 FIGURE

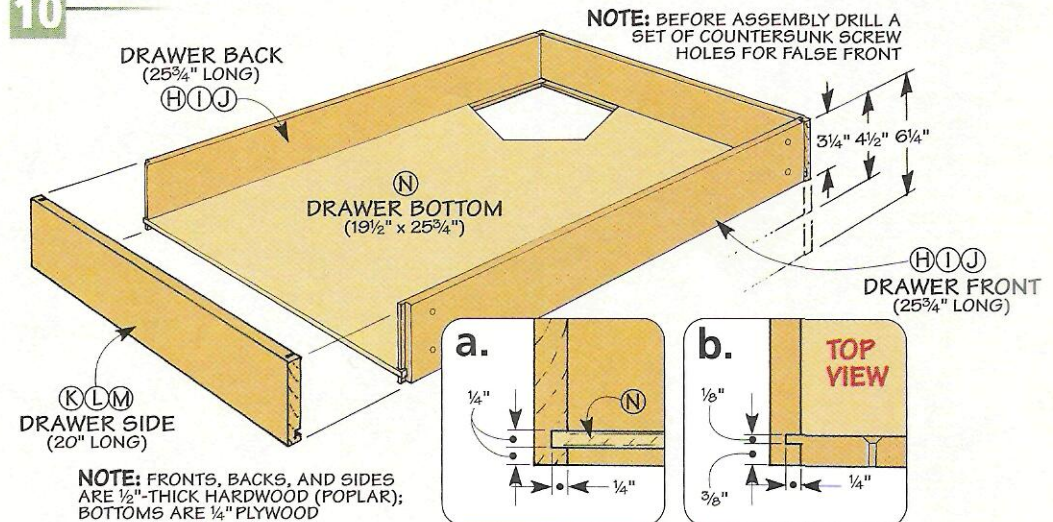

Top & Dividers

If you are making the storage cabinet to fit underneath a workbench, you can stop at this point. All that you have to do is slide the units under your bench and fasten them in place. (See the opposite page.)

However, if you are building the "upright" storage cabinet, you will need to add a base and a top, plus a divider that fits in between the two cases, as shown in Figure 11.

I started by making the base and divider. (These two pieces are identical.) Each one is simply a plywood panel with hardwood edging on three sides (Figure 12). After cutting the *base/divider panels (R)* to size, you can mitre the *edging (C)* and glue it to the front and sides. Then trim the edging flush and round over the edges, as shown in Figure 12b.

Once you're finished with these pieces, they can be attached to the lower case. The base is screwed to the bottom of the case. And the divider is screwed to the top of the lower case, as shown in Figure 11b.

Top - The top of the cabinet is a just a little more involved. Like the base and divider, it starts out as a plywood *top panel (S)*. Then strips of hardwood *edging (C)* are added to the front and back edges *only*.

Instead of thin strips of edging, the ends of the top are covered with 3"-wide pieces of hardwood. These ends overhang the sides of the cabinet, creating a ledge that makes it a little easier to get a grip on the cab-

inet when pulling it around the shop. Each *top end (T)* is just a piece of hardwood with a centered groove cut along one edge (Figure 12a). A tongue is cut along each end of the top panel to match these grooves. Then the ends are cut to length and glued to the top panel. To complete the top, the edges are rounded over, just as you see in Figure 12a. Then the top is screwed

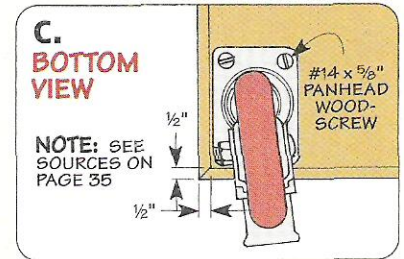
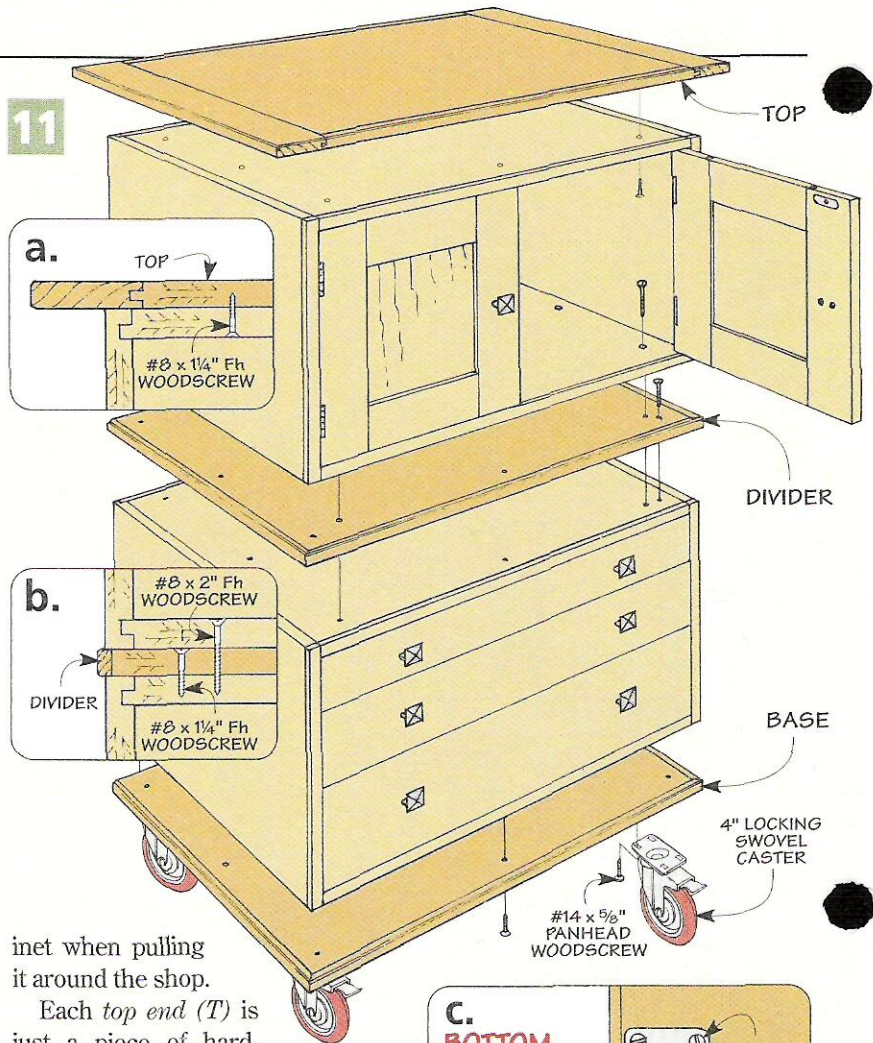

to the upper case (Figure 11a).

Casters - To make the storage cabinet mobile, I added casters to the bottom of the base. These are shown in Figures 11 and 11c. I used 4" locking swivel casters all around. These allow you to move the cabinet in any direction and then lock the wheels down once you have it where you want it.

Once the casters are attached, the last thing to do is place the upper case on top of the lower case, center it from side to side and screw the two together, just as you see in Figure 11b.

12 FIGURE TOP END (3" x 22 3/8" - 3/4"-THICK HARDWOOD)

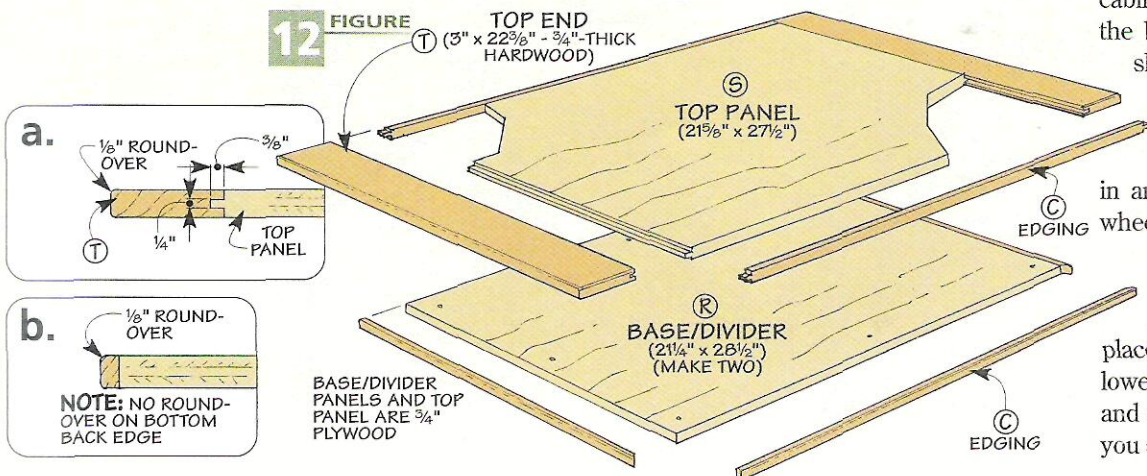

Workbench Storage

If you are building the storage cabinets to fit underneath a workbench, you might want to consider using MDF instead of expensive plywood for the top, bottom, and sides. Once these pieces are edged in hardwood and the cases are slipped into place underneath the bench, you won't be able to tell the difference from the outside. (If you look under the top of the bench, you will be able to see the MDF top of the case, but from the front, you won't be able to tell.)

Regardless of what material you use for the cabinets, there are a few things you should consider when it comes to sizing the cases, particularly if you are building them to fit your own bench.

We sized the width of our cases to fit between the two ends of the bench — with a very slight gap at each end. (This extra room makes it a little easier to slide the storage cabinets in place.)

As for the depth of the cases, we sized them so the front and back edges sit just behind the edges of the lower rails of the workbench, as you can see in detail 'b' below.

When it comes to the height of the cases, you will want to make sure you



leave enough clearance between the benchtop and the top of the storage cabinets for any bench dogs or vise hardware, see detail 'a.' (Three to four inches of clearance should be fine.)

built, all you have to do to install them is slide them in place and fasten them down to the shelf of the bench with a few screws.

Once you have the storage cabinets

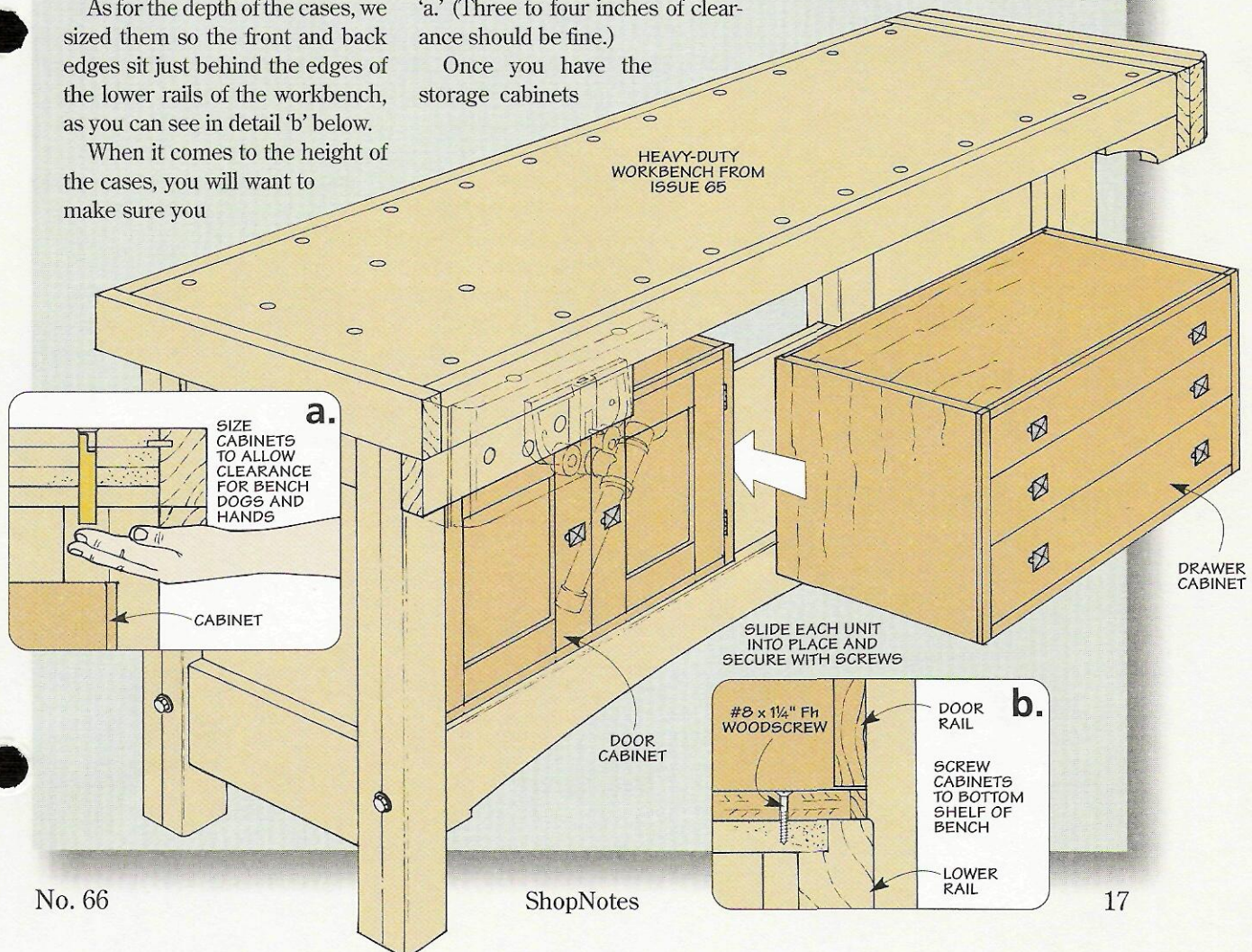

Tongue & Groove Joinery

Whenever I'm building frame and panel assemblies that use a plywood or hardboard panel, I almost always use a tongue and groove joint. There are a few good reasons for this. Besides being quick and easy to make, the assembly is incredibly strong. That's because a hardboard or plywood panel can be glued into the frame.

GROOVES

The first step in creating a tongue and groove joint is to cut the grooves in the rails and stiles that make up the frame.

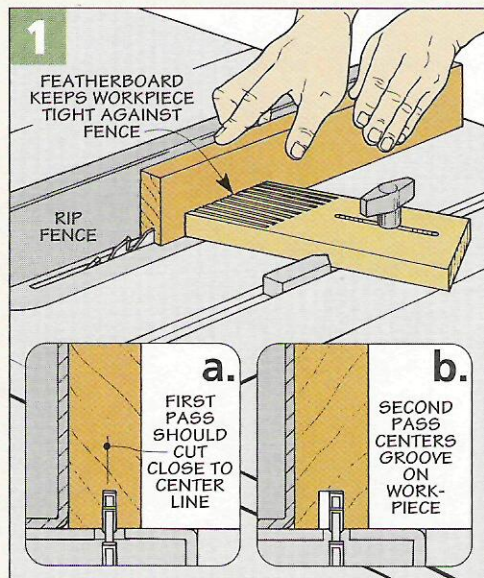

In most cases, the groove is centered on the edge of the frame piece. Start by adjusting the rip fence on your table saw so the blade cuts *close* to the center, as shown in Figures 1

and 1a. But don't worry about being centered perfectly on the first try.

Flip Workpiece – The reason is simple. After making the first pass, just flip the workpiece end-for-end and make a second pass (Figure 1b). This way, even if your blade isn't perfectly centered, the groove will be.

To fine-tune the width of the groove, nudge the rip fence over a little and make another cut. Keep in mind that you're removing material from *both* sides of the workpiece. So it's best to make small adjustments and sneak up on the final width.

Troubleshooting – Getting a perfectly centered groove involves more than just flipping a workpiece. It's important that it stays tight against the rip fence. So I like to use a featherboard to hold it tight (Figure 1).

Another problem is not cutting the groove deep enough. This can happen when the workpiece "rides up" during the cut, causing a step in

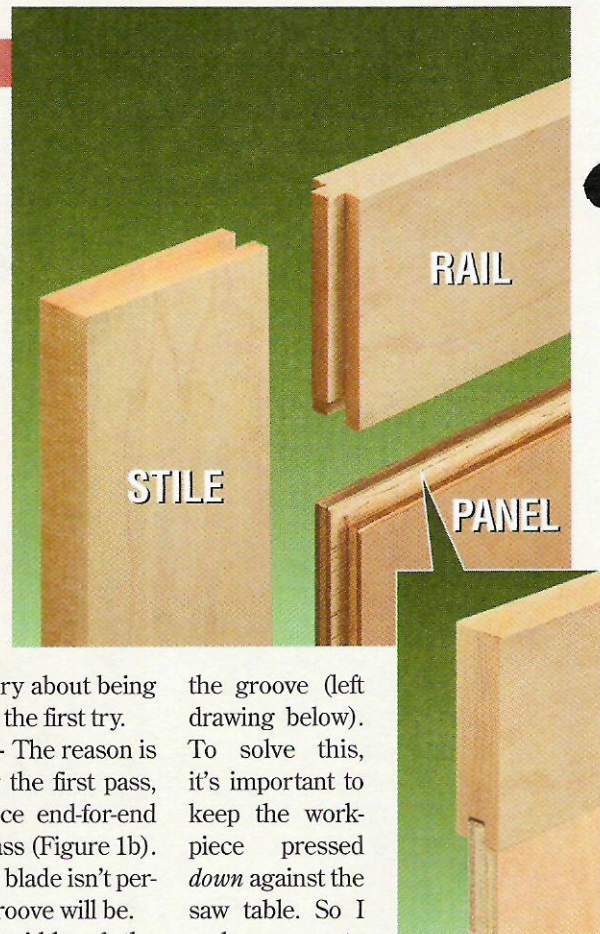

the groove (left drawing below).

To solve this, it's important to keep the workpiece pressed *down* against the saw table. So I make sure to check the groove after each cut and, if necessary, make another pass.

Groove Width – There is one thing to mention about the width of the groove. If I'm using 1/4" plywood or hardboard, I cut the groove to match the thickness — which is often slightly less than 1/4" thick.

But if I'm working with 1/2" plywood, like on the workstation, I cut a 1/4"-wide groove and then cut tongues on the panels to match (see inset).

Blades – One last thing. If you'll see the bottom of the grooves (like on a frame and panel door), you might want to consider using a rip blade to

TROUBLESHOOTING GROOVES

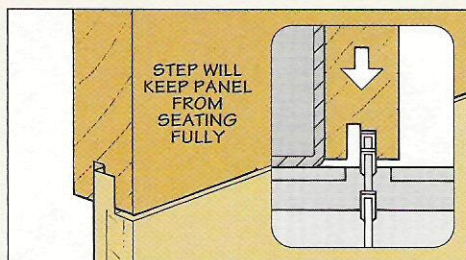

▲ **Downward Pressure.** To prevent stepped cuts in the bottom of the groove, hold the workpiece firmly against the saw table.

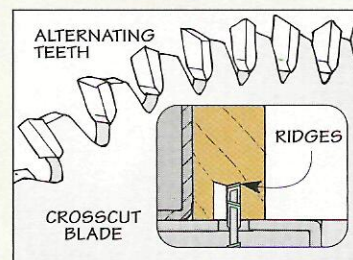

▲ **Blade Choices.** A crosscut blade produces grooves with ridges. A better choice for cutting grooves is a rip blade. The flat-topped teeth produce a groove with a perfectly flat bottom.

make the cut. It leaves a perfectly flat bottom (see bottom of page 18).

TONGUES

Once the grooves are complete, the next step is to cut the tongues on the ends of the rails. I prefer to use a dado blade to cut the tongue. This way, you can cut the tongue in two passes using a single setup.

To do this, start by burying the dado blade in an auxiliary fence (Figure 2). Then adjust the fence to set the length of the tongue (Figure 2a).

Blade Height – The next step is to set the height of the blade to establish the thickness of the tongue. As before, the idea is to make two passes, flipping the workpiece over between each pass (Figure 2b). This will center the tongue on the rail.

But you still need a starting point. A good guide is the groove itself. Simply raise the blade until it's just about even with the groove (Figure 2a). Here again, make your cuts on a test piece and check the thickness of

the tongue. It should fit the groove with a slightly snug fit.

After cutting all the tongues on both ends of all the rails, you can turn your attention to the tongues on the 1/2" plywood panels. For this you can leave the rip fence set and simply adjust the height of the blade to cut a rabbet along the edge of the panel. Again, it's best to sneak up on the fit.

ASSEMBLY

At this point, you're just about ready to glue up the assembly. But it's always a good idea to dry assemble things to check for any problems.

Sand – Then you can sand the face of the panel as well as the inside edges of the stile and rails. These areas are difficult to sand later.

Glue – Like most glue-ups, the trick is using enough glue to make a strong joint, but not so much that it runs all over the place. I start by gluing the rails to the panel, applying glue to the groove and *inside* face of the tongue on the panel (Figure 3).

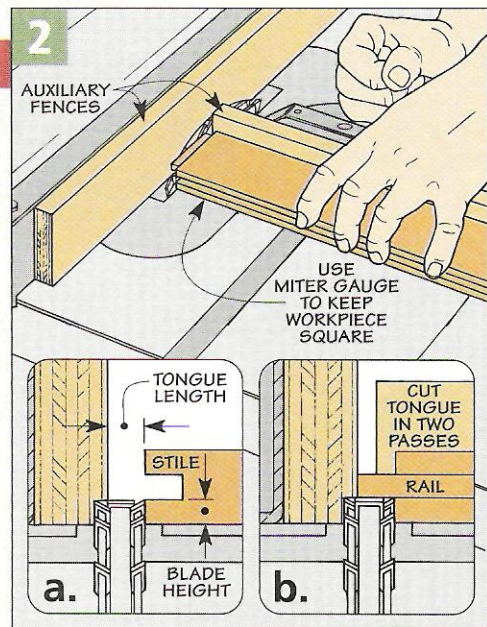

Attaching the stiles is just a matter of repeating the same process. But here I apply glue to *both* sides of the tongues on the rails (Figure 3b).

After clamping the pieces together (Figure 4), check to see that the frame is flat and square. If it isn't flat, try loosening the clamps a bit. And if it isn't square, try repositioning the clamps slightly.

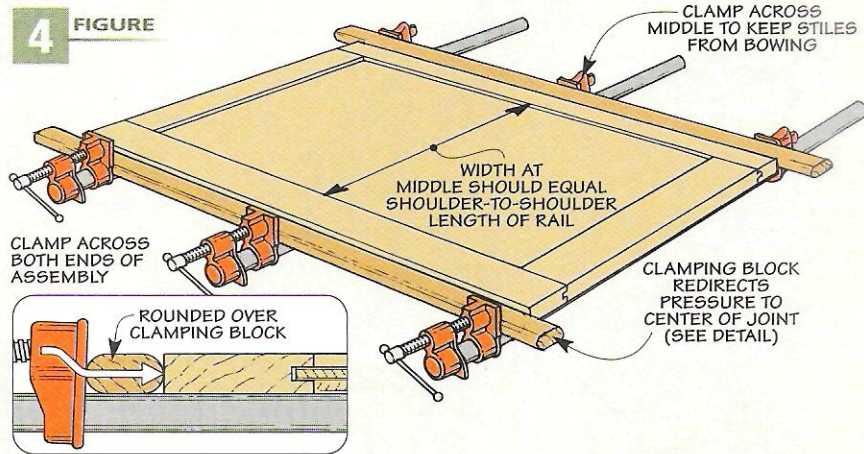
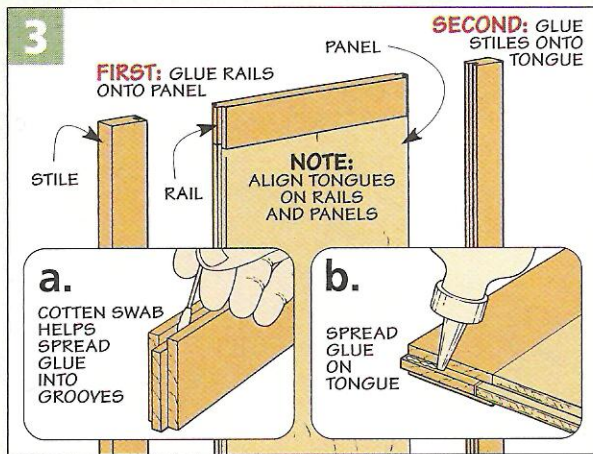

TROUBLESHOOTING TONGUES

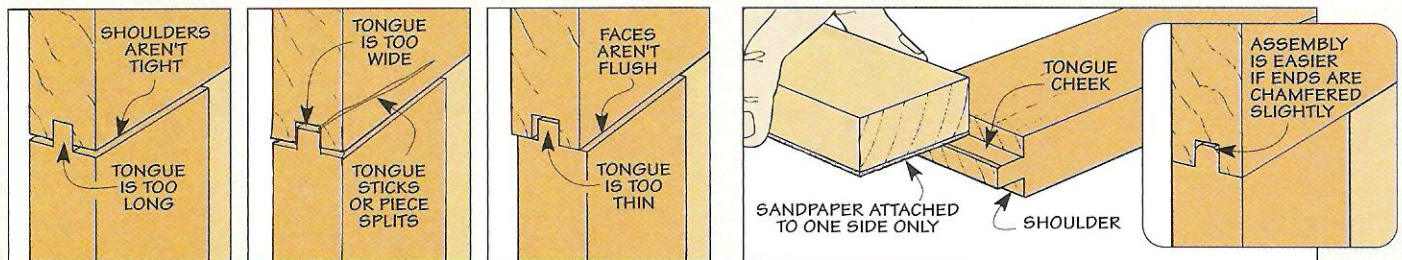

▲ **Tongue Troubles.** When the tongue is too long (left) or too wide (center), assembly is difficult. A tongue that's too thin (right) results in a poor glue joint and makes it hard to align the faces.

▲ **Fitting the Tongue.** Lightly sand the tongue cheeks and chamfer the ends to get a good fit in the groove. But stay clear of the shoulder to keep it sharp.

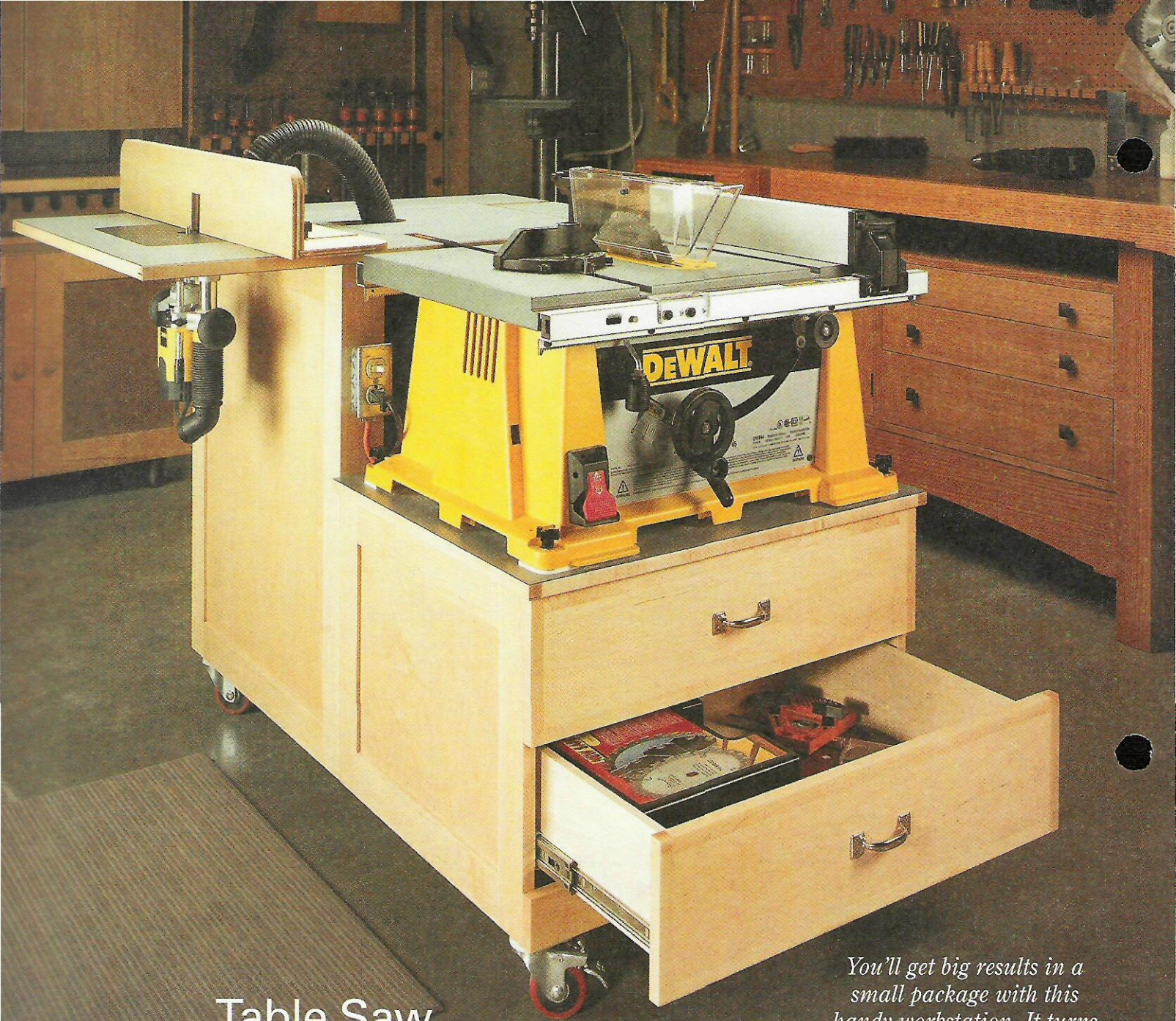

Table Saw Workstation

You'll get big results in a small package with this handy workstation. It turns your portable table saw and router into hard-working "stationary" tools.

Portable power tools, like a table saw or router, are great when you're working away from the shop. But once they're back "home," the challenge is to make them perform like hard-working stationary tools. The workstation shown above provides the solution.

The workstation consists of two separate cabinets. One supports the saw, and the other acts as an outfeed table when you're ripping sheet goods or long stock, like you see in photo A on the opposite page.

Router Table – To add to the workstation's versatility, the top of the outfeed cabinet doubles as a table for

mounting a hand-held router. Combined with an easy-to-build fence, you can handle just about any routing task.

Dust Collection – The outfeed cabinet also features a handy storage area for a shop vacuum. Simply open the door at the back and roll it inside. An access panel at the top of the cabinet makes it easy to connect the vacuum to either the saw or the router table fence (photo B).

Storage – Have a wide variety of accessories for your portable tools or shop vacuum? To keep them organized and easily accessible, the saw cabinet has a pair of deep drawers that ride on full-extension slides (photo above).

FEATURE PROJECT

ShopNotes To download a free Cutting Diagram for the Table Saw Workstation, go to: www.shopnotes.com

GO ON-LINE EXTRAS

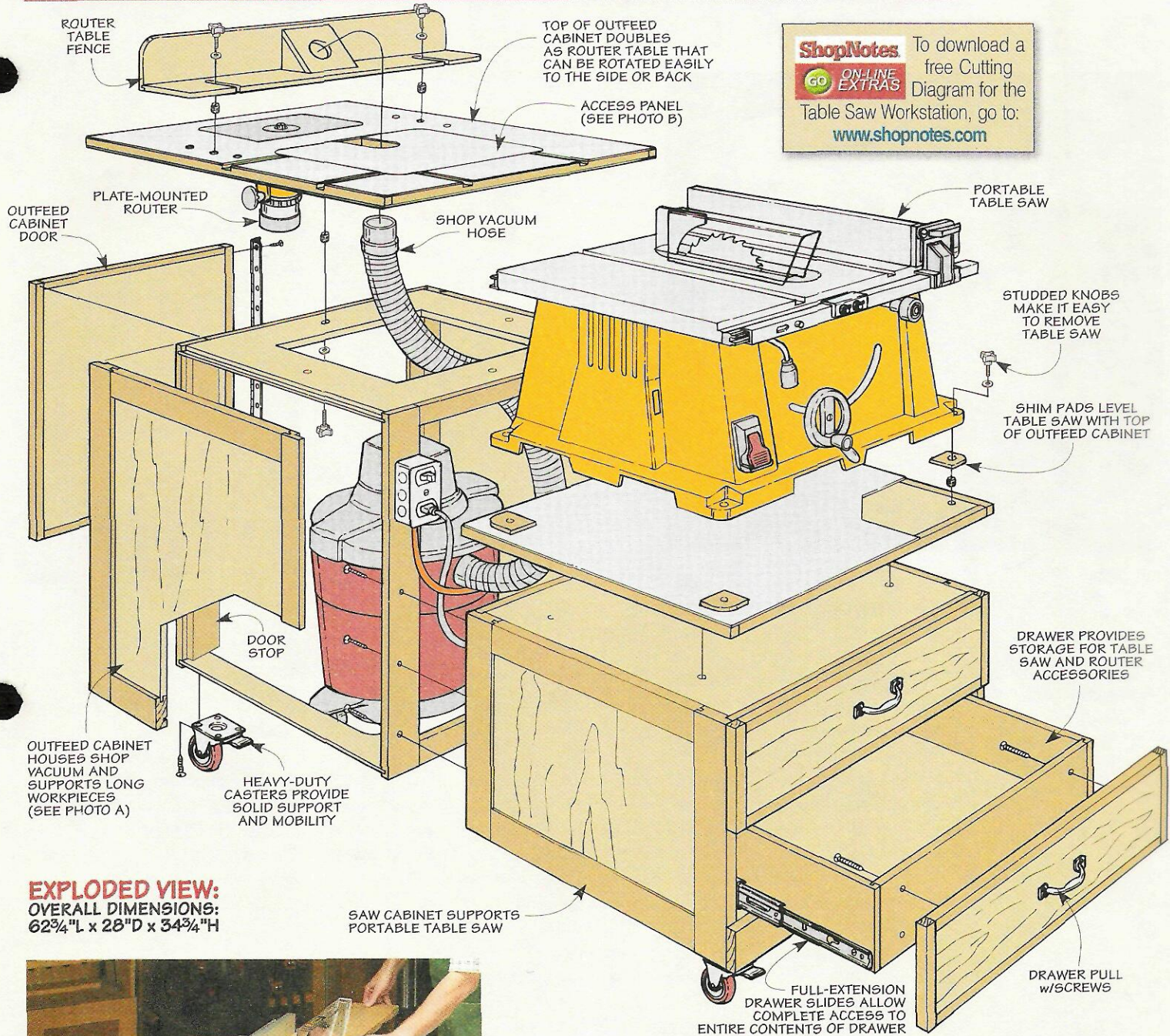

EXPLODED VIEW:
OVERALL DIMENSIONS:
 62³/₄"L x 28"D x 34³/₄"H

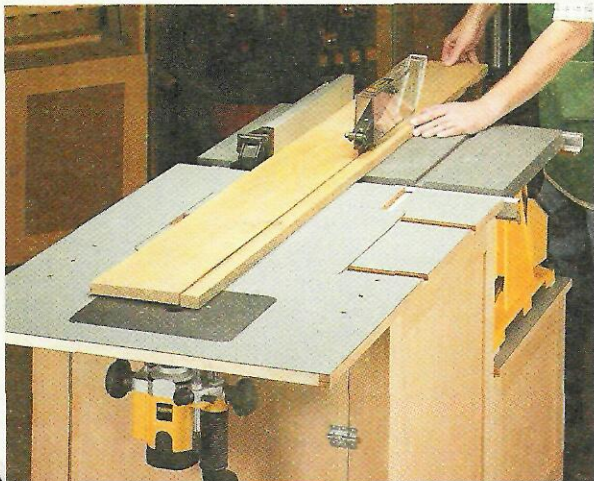

A. Convertible Top. Positioning the top so it extends over the back of the outfeed cabinet creates a long, stable support surface when ripping long workpieces.

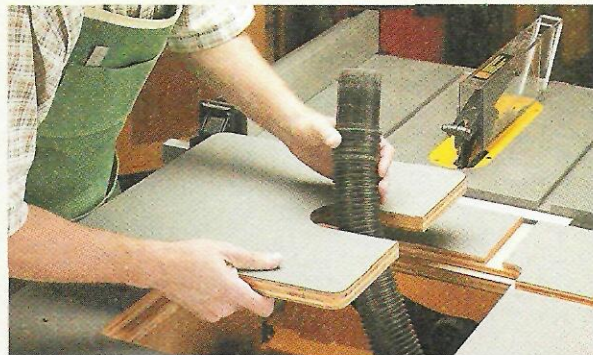

B. Shop Vacuum Access. A removable panel provides quick access when hooking the dust hose from the shop vacuum up to the table saw or router table fence.

Saw Cabinet



▲ **Saw Cabinet.** As a stand-alone unit, the saw cabinet provides solid support for a portable saw with plenty of storage for accessories.

As I mentioned earlier, this workstation is made up of *two* separate cabinets — a low cabinet provides basic support for the table saw (see photo above), and adding on a taller cabinet provides outfeed support when you're working with long stock.

Besides providing solid support for the table saw at just the right working height, there's the added storage that's a great bonus. Plus, you can quickly and easily remove the saw.

Size — Speaking of height, the cabinet shown in Figure 1 will accept portable saws up to 13" tall. With the casters added, the table of the saw is about 35" high — a comfortable working height.

If your saw is less than 13" high, don't worry. You can add spacers to raise the saw table so it's at a

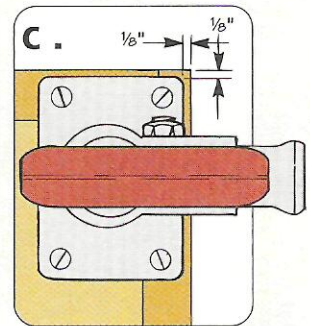
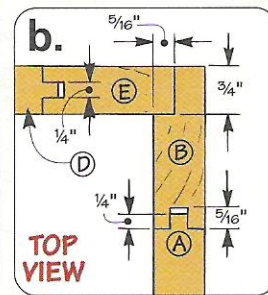
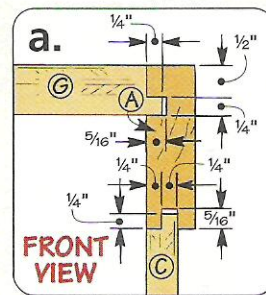
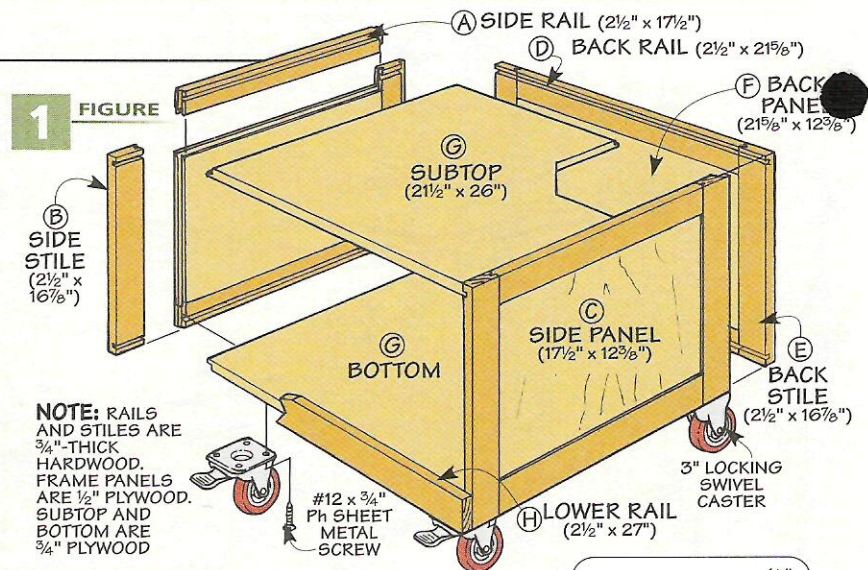

comfortable height or level with the outfeed table (more on this later).

Frames & Panels — There's nothing tricky about building the cabinet. It's just a large box made up of three frame and panel assemblies along with a plywood subtop and bottom, like you see in Figure 1.

Each assembly consists of a pair of rails and stiles that wrap around a plywood panel. I started on the frames by cutting the *side* and *back rails* (A, D) and *side* and *back stiles* (B, E) to final size.

Once that's complete, you can work on the tongue and groove joint

that holds the frame together. The dimensions are shown in Figures 1a and 1b. Note: For a few tips on cutting perfect-fitting tongue and groove joints the first time, check out the article on page 18.

After cutting the tongues and grooves, you can turn your attention to the panels that fit inside each of the frames. Each *side panel* (C, F) is just a piece of 1/2" plywood.

Why 1/2" plywood? The reason has to do with mounting the drawer slides later. After cutting a rabbet around the edges to form a tongue (Figure 1a), the panel will fit in the grooves so the inside face of the panel is flush with the frame. This makes it easy to mount the drawer slides.

Cabinet Assembly — Once the rabbets are complete, you can glue up each frame assembly and begin work on assembling the cabinet.

To join the back assembly to the side assemblies, there's a wide rabbet along the back edge of each side assembly, as in Figure 1b.

Next, to accept the subtop and bottom, I cut narrow grooves (1/4")

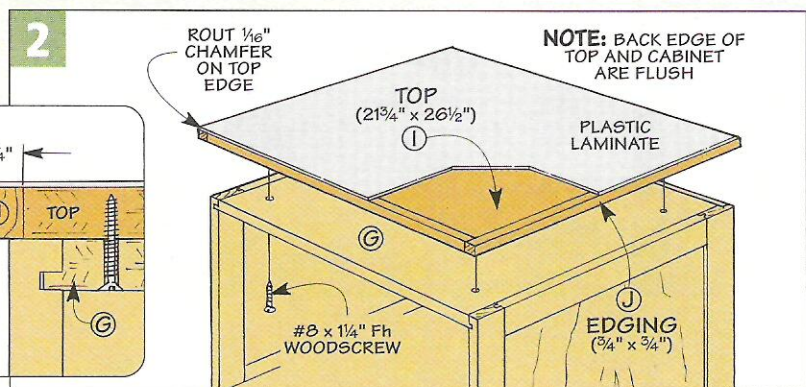

near the top and bottom edges of all the frames (Figure 1a). These grooves accept tongues cut along three edges of the *subtop* and *bottom* (G), which you can also see in Figure 1a. Once the tongues are cut, you can glue up the cabinet.

Finally, to provide some rigidity to the front of the cabinet and to cover the plywood edge at the bottom, I added a *lower rail* (H) made from 3/4"-thick hardwood (Figure 1).

Top - Although the cabinet already has a "top," I wanted to make sure the table saw would have solid support. To accomplish this, I added a laminated top. The *top* (I) is nothing more than a piece of 3/4" plywood wrapped with 3/4"-thick hardwood *edging* (J), as in Figure 2.

Then to provide a smooth, durable surface, I glued on an oversized layer of plastic laminate and trimmed it flush with the edging. After screwing the top in place so it was flush at the back and centered side to side, I eased the sharp edge by routing a small chamfer (Figure 2a).

DRAWERS

With the basic cabinet complete, you're ready to add the two drawers that you see in Figure 3.

Size Drawers - What's important to keep in mind as you size the drawer parts is to allow for 1/2" of space on each side for installing the drawer slides (Figure 3c).

After planing your stock down to 1/2" thick, you can cut the drawer *fronts/back* (K) and *sides* (L) to the dimensions shown in Figure 3.

Tongue & Dado Joinery - The joinery for the drawers is cut entirely on the table saw. A single kerf at the ends of each side accept tongues cut on the ends of the fronts and backs, like you see in Figure 3a.

Before assembling the drawers, you'll need to cut a 1/4"-wide groove near the bottom edge of all the drawer pieces to hold the bottom (Figure 3c). It's also a good idea to drill a set of countersunk screw holes in each drawer front for attaching the false fronts later (Figure 3a).

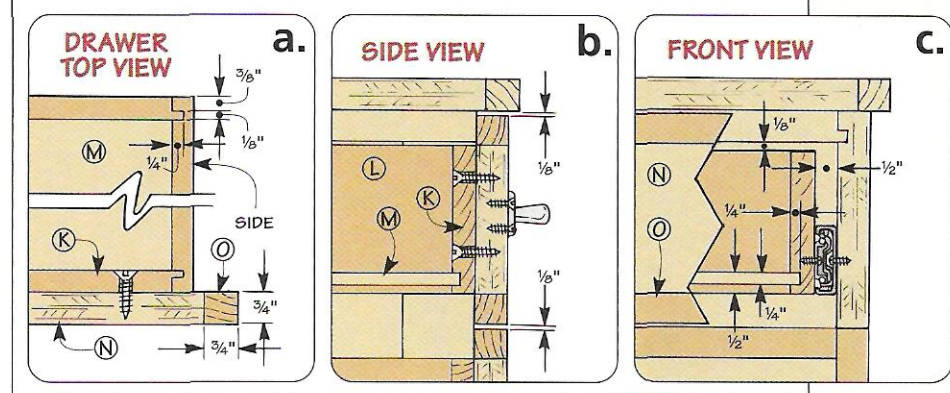
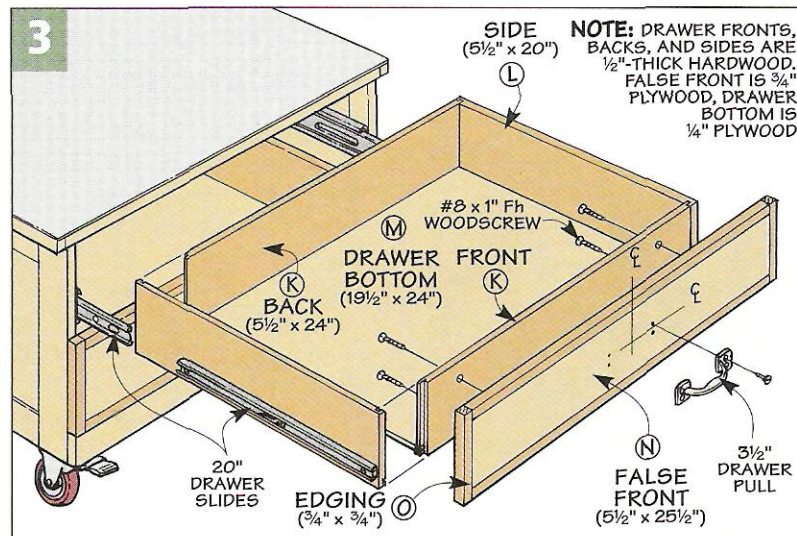

After cutting the drawer *bottom* (M) to size from 1/4" plywood, you can glue up each drawer.

Drawer Slides - The drawers travel on full-extension metal slides. This makes it easy to reach items in the back of the drawer. Installing the slides is just a matter of screwing one half to the cabinet and the other half to the drawer. (The slides are positioned flush with the bottom edge of each drawer, as in Figure 3c).

False Fronts - After mounting the drawer slides, you can add the *false fronts* (N). These are pieces of 3/4" plywood trimmed with 3/4"-thick hardwood *edging* (O). The false fronts are sized so they're flush with the sides of the cabinet and create a 1/8" gap above and below each drawer (Figure 3b).

Finally, I centered a drawer pull on the front of each drawer and screwed them in place (Figure 3).

Casters - If you only plan on building the saw cabinet, you can

add all four locking swivel casters at this point. The casters are set in 1/8" from each corner of the cabinet, like you see in Figure 1c. (For more on the casters, refer to page 35.)

Materials & Hardware

A Side Rails (4)	3/4 x 2 1/2 - 17 1/2
B Side Stiles (4)	3/4 x 2 1/2 - 16 7/8
C Side Panels (2)	17 1/2 x 12 3/8 - 1/2 Ply.
D Back Rails (2)	3/4 x 2 1/2 - 21 5/8
E Back Stiles (2)	3/4 x 2 1/2 - 16 7/8
F Back Panel (1)	21 5/8 x 12 3/8 - 1/2 Ply.
G Subtop/Bottom (2)	21 1/2 x 26 - 3/4 Ply.
H Lower Rail (1)	3/4 x 2 1/2 - 27
I Top (1)	21 3/4 x 26 1/2 - 3/4 Ply.
J Edging	3/4 x 3/4 - 9 Ln. Ft.
K Drawer Frts./Bcks (4)	3/4 x 5 1/2 - 24
L Drawer Sides (4)	3/4 x 5 1/2 - 20
M Drawer Bottoms (2)	19 1/2 x 24 - 1/4 Ply.
N Drawer False Frts. (2)	5 1/2 x 25 1/2 - 3/4 Ply.
O Drawer Edging	3/4 x 3/4 - 11 Ln. Ft.
• (8)	#8 x 1" Fh Woodscrews
• (4)	#8 x 1 1/4" Fh Woodscrews
• (4)	3"-Dia. Locking Swivel Casters
• (16)	#12 x 3/4" Ph Sheet Metal Screws
• (2 Pr.)	20" Drawer Slides w/screws
• (2)	3 1/2" Drawer Pulls w/screws

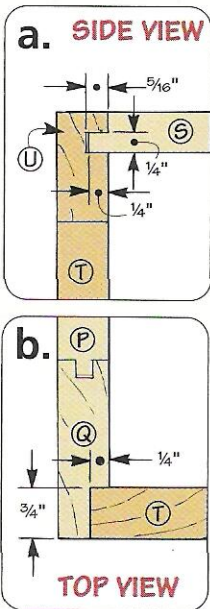
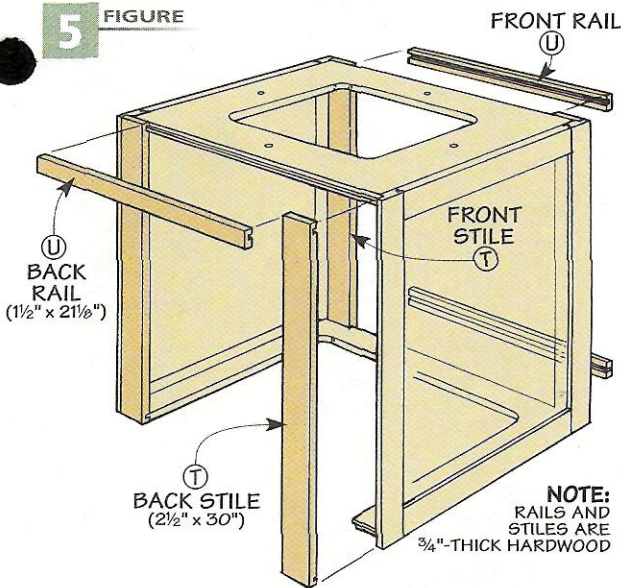

Materials

P Side Rails (4)	3/4 x 2 1/2 - 22 1/2
Q Side Stiles (4)	3/4 x 2 1/2 - 30
R Side Panels (2)	22 1/2 x 25 1/2 - 1/2 Ply.
S Subtop/Bottom (2)	26 x 26 - 3/4 Ply.
T Front/Back Stiles (4)	3/4 x 2 1/2 - 30
U Front/Back Rails (3)	3/4 x 1 1/2 - 21 1/8
V Door (1)	19 3/8 x 26 7/8 - 3/4 Ply.
W Edging	3/4 x 3/4 - 9 Ln. Ft.
X Door Stop (1)	3/4 x 2 3/4 - 28 1/2

Hardware

- (10) #8 x 1/4" Fh Woodscrews
- (1) 1 1/2" x 28 3/8" Piano Hinge w/screws
- (1) Barrel Catch w/screws

Note: I sized my opening to accept a shop vacuum up to 21" wide.

Assembly - With both the subtop and bottom complete, you can assemble the outfeed cabinet. There's nothing tricky here, just be sure to keep the cabinet square as the glue dries since there isn't a front or back frame to hold the shape.

Frame Pieces - To provide some rigidity to the cabinet and give it a "framed" look, I added 3/4"-thick hardwood strips to the front and back of the cabinet. These strips cover the edges of the plywood and fit into the rabbets cut in the side assemblies, as shown in Figure 5.

After cutting the *front* and *back stiles* (T) to final size, the only joinery to complete is to cut a dado at each end to fit the tongues on the subtop and bottom. Then you can glue the stiles in place.

Installing the *front* and *back rails* (U) is even easier. Once you cut them to fit between the stiles, all that's left to do is to cut a groove near one edge that fits the tongue along the edge of the subtop and bottom. Then the rails can be glued in place. Note: To keep the back of the cabinet open for the shop vacuum, you'll only need a single rail at the top.

Add Door - To close off the back of the cabinet, there's a *door* (V) made from a piece of 3/4" plywood wrapped with 3/4"-thick *edging* (W),

as seen in Figure 6. Attaching the door to the cabinet is just a matter of screwing a piano hinge in place and then adding a catch to keep it closed (Figures 6 and 6a). And to prevent the door from swinging inside the cabinet, there's a *door stop* (X) made from 3/4"-thick hardwood (Figure 6a).

Join Cabinets - Once you've glued and screwed the door stop in place, you can attach the outfeed cabinet to the saw cabinet. They're just screwed together (Figure 6b). Finally, you can add the casters to the outside corners of the workstation (refer to Figure 1a on page 22).

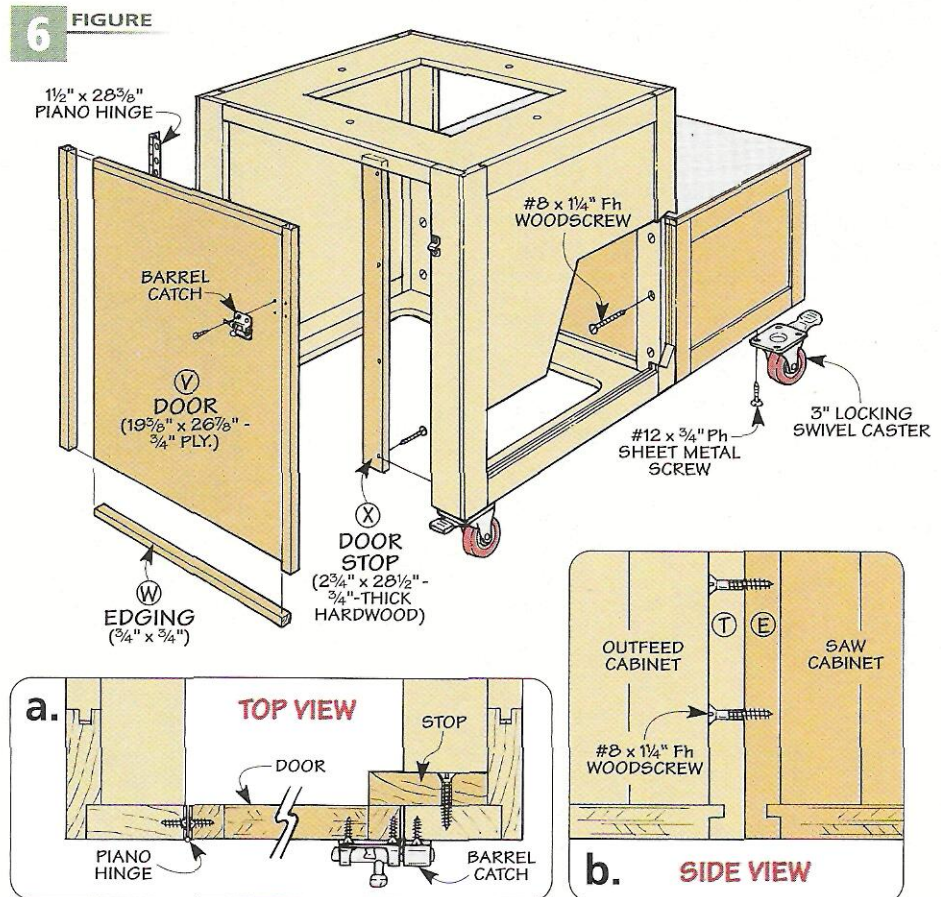

Outfeed Top



▲ **Access Panel.** Just "pop out" the panel from the top of the outfeed cabinet to provide easy access to the shop vacuum inside.

With the outfeed cabinet complete, you're ready to add the outfeed top. The top shown in Figure 7 incorporates a number of handy features.

First, you can see that the top extends past the end of the cabinet. This ensures that you'll have solid support when ripping long workpieces or sheet goods.

Then to provide additional capability, the top doubles as a router table. To do this, there's an opening at one end of the top that allows you to "drop in" a router mounted to an insert plate. And depending on your needs, you can rotate the top to the side for more convenient access, like the photo shown on page 20.

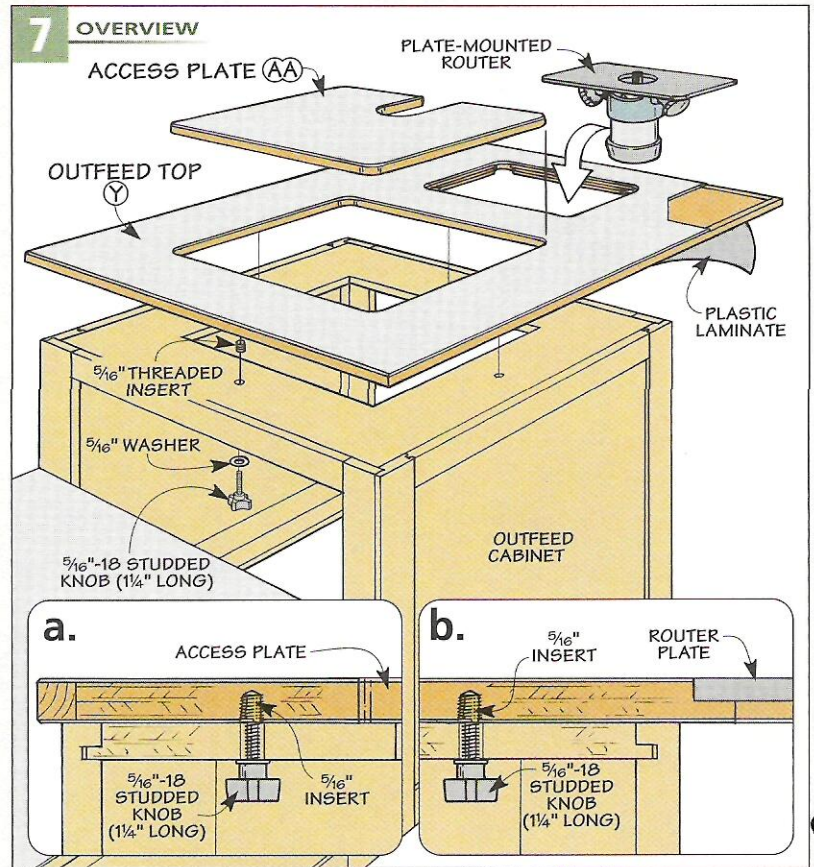

Finally, you'll see a second opening that provides access to the *inside* of the outfeed cabinet. All you need to do is remove the access plate and reach inside to hook the vacuum hose to the table saw (see margin) or the router table fence.

Top – Building the *outfeed top* (Y) isn't all that difficult. It's just a

single layer of $\frac{3}{4}$ " plywood with $\frac{3}{4}$ "-thick *edging* (Z), applied around the edges, as illustrated in Figure 8. Unlike the top for the saw cabinet, you'll notice that I covered *both* sides of the top with plastic laminate.

Why both sides? Since the top isn't attached permanently and one end extends past the edge of the cabinet, laminating both sides helps stiffen the plywood to prevent sagging.

Note: To trim the laminate flush and ease the sharp edges, I routed a small ($\frac{1}{16}$ ") chamfer along both the top and bottom edges (Figure 8a).

Openings – As I mentioned, there are two openings in the top — one for the router plate and the other for an access plate. The secret to getting a perfect fit between the openings and the plates is to use the plates as templates when you cut the openings. To do this, you'll need to have the plates in hand before you start.

Plates – To mount the router, I bought a commercial insert plate

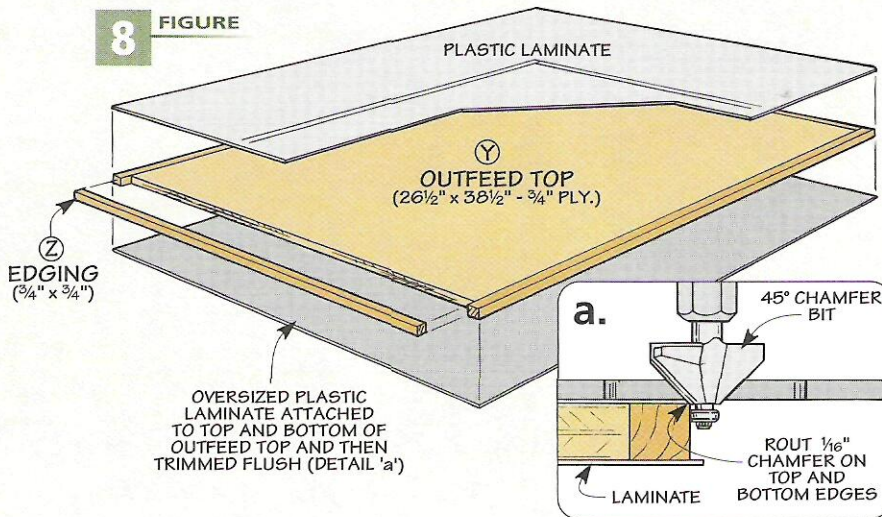

(for sources, see page 35). But you could make your own. For the *access plate* (AA), I used a small piece of $\frac{3}{4}$ " plywood (Figure 9). Although there isn't any need for edging, both sides are laminated so it matches the thickness of the top.

After rounding the edges, I cut a U-shaped opening centered on one edge (Figure 9). This provides an opening for the hose from the shop vacuum to pass through when it's attached to the router table fence.

Plate Openings – With both plates in hand, the next step is to create the openings they fit into. The location of these openings is shown in Figure 9. The nice thing is, you can use the same procedure to cut both openings. For more information on this procedure, refer to the article on page 30.

Besides cutting a perfect-fitting opening, the procedure also creates a lip in the top for the router plate to rest on so it's perfectly flush with the top of the outfeed table.

9 FIGURE

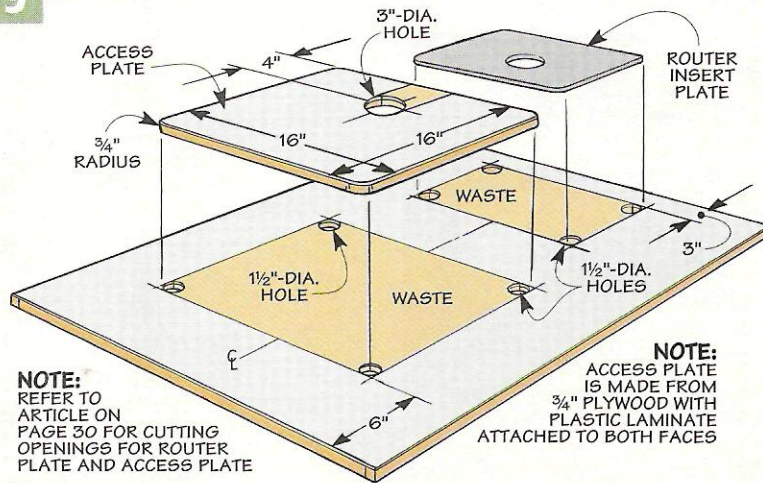

- Materials**
- Y Outfeed Top (1)
26 1/2 x 38 1/2 - 3/4 Ply.
 - Z Edging
3/4 x 3/4 - 12 Ln. Ft.
 - AA Access Plate (1)
16 x 16 - 3/4 Ply.

- Hardware**
- (4) 5/16" Threaded Inserts
 - (4) 5/16"-18 Studded Knobs (1 1/4" Long)
 - (4) 5/16" Washers

But for the access plate, you won't need to create a lip. The opening you cut earlier in the subtop of the cabinet is smaller and forms its own "lip" for the access panel to rest on.

Attach Top – Once the openings are cut, the top is ready to be attached. To do this, I used a set of studded knobs that fit into threaded inserts in the bottom face of the top,

like you see in Figures 7a and 7b. To locate the inserts, clamp the top in position so it overhangs the front and sides of the cabinet evenly (1/2"). Then use the holes in the cabinet as a guide.

After drilling holes, you can install the inserts. This can be a little tricky. To make it easier, I used the installation tool shown in the box below.

Installing Threaded Inserts

Threaded inserts, like the ones shown below, are a quick way to connect two pieces, yet still make it easy to take them apart. The trick is keeping the insert straight as you're screwing it in place — which isn't always easy. To solve this problem, I made the insert tool shown at right.

Insert Tool – The insert tool is made from a block of 1 1/2"-thick hardwood with a 3/4"-deep notch cut in one corner, as illustrated in the drawing at far right.

A counterbored hole is drilled through the notch to hold a 5/16"-18 bolt and nylon bushing. The through hole is sized to hold the bolt and the 1/2"-dia. counterbore is drilled 1 1/4" deep to accept the 5/16" I.D. bushing. The bushing holds the hex bolt straight while you tighten it down.

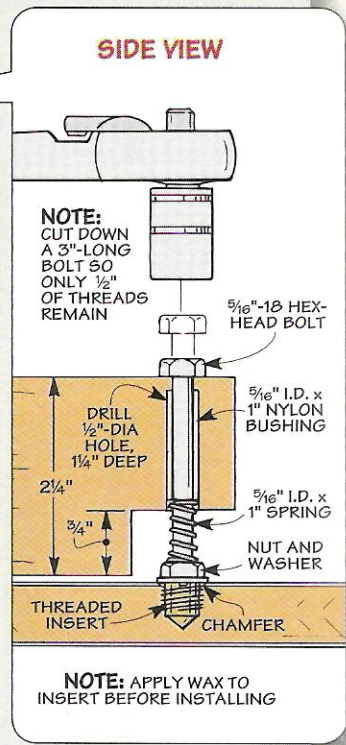
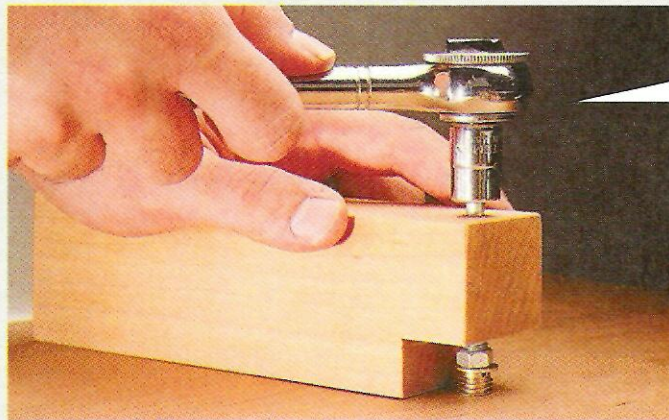

Finally, between the bushing and the nut and washer that are tightened against the insert, I added a spring. It provides just enough downward pressure to help the threads on the outside of the insert to begin cutting into the wood.

Note: Before screwing the insert in place, it's a good idea to add a slight chamfer to the starter hole. This prevents the insert from chipping out the edges as it's screwed in place.

Mounting the Table Saw



▲ Miter Slots. Routing slots in the top of the outfeed table provides clearance for the bar of the miter gauge when making crosscuts.

At this point, the basic construction of the workstation is complete. All that's left to do is mount the table saw and add some slots to the top of the outfeed table to accept the bar of the miter gauge (see photo).

Mount Saw – To mount the saw securely, yet still allow it to be removed easily, I once again turned to a set of threaded inserts. This makes it easy to use studded knobs and washers to secure the saw.

To accurately locate the inserts on the top of the saw cabinet, I used the mounting holes in the saw itself to lay out the insert holes (Figure 10). Just position the saw so it's centered side to side with clearance in the back for the rip fence rail and the blade guard. After marking the location of each insert, you can drill the holes and install the inserts just like you did before.

Riser Pads – The next step is to bring the top of the saw table up so it's flush with the outfeed table. In my case, all I needed was a set of "spacers" about 1/8" thick. So after planing some material down, I cut out a set of pads (BB) to fit the corners of the saw. Then after drilling a hole through each pad, I secured the saw to the stand with knobs and washers (Figure 10a).

Miter Slots – Once the saw is mounted, you'll need to add slots to the top of the outfeed table to allow the miter gauge to slide completely past the blade when making a crosscut.

The slots don't need to be very long. In my case, the slots ran from the front edge of the outfeed top to the opening for the access plate, as in Figure 11.

Guide – An easy way to cut the slots in just the right spot is to use a router and straight bit along with a shop-made guide. The guide is nothing more than a piece of 3/4" plywood with a runner set in a groove cut in the bottom (Figure 11).

Since some table saws use a miter bar with washers that fit a T-slot, I used a 1"-dia straight bit to cut the slots. Since the miter bar doesn't have to fit the slot tight, this provides a little "wiggle" room for the bar.

After mounting the router to the guide so the bit is aligned with the runner, adjust the bit to make a cut just a hair deeper than the thickness of the miter bar. (In my case, I set the bit to make a 3/8"-deep cut.)

At this point, cutting the slots is easy. Start by removing the access plate. Then set the guide (and router) on the saw so the runner slips into the miter slot and the bit is just past the end of the saw (Figure 11).

Now turn the router on and slide the guide along the slot to rout a

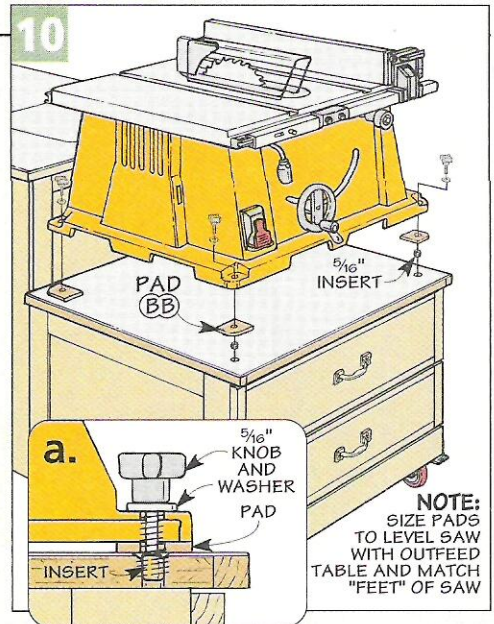

NOTE: SIZE PADS TO LEVEL SAW WITH OUTFEED TABLE AND MATCH "FEET" OF SAW

Materials

- BB Pads (4)
(Custom size to fit table saw)
- CC Base (1)
6 1/4 x 32 - 1/2 Ply.
- DD Face (1)
5 x 32 - 3/4 Ply.
- EE Braces (2)
3 1/2 x 3 1/2 - 1/2 Ply.
- FF Cover (1)
5 x 5 15/16 - 1/2 Ply.

Hardware

- (10) 5/16" Threaded Inserts
- (4) 5/16"-18 Studded Knobs (Length to fit saw)
- (2) 5/16"-18 Studded Knobs (1" Long)
- (6) 5/16" Washers

groove from the front edge of the outfeed table to the access plate opening.

After routing one groove, simply move the guide to the other miter slot and repeat the process. It's also a good idea to rout miter slots with the top positioned to the back. This way, you can use the miter gauge in either position (Figure 11).

Shop Vacuum Switch – With the shop vacuum inside the outfeed cabinet, turning it on and off can get to be quite a hassle.

To avoid this, I added a switched receptacle so I could control it from the outside of the cabinet. You can see how I did this by checking out the box on the opposite page.

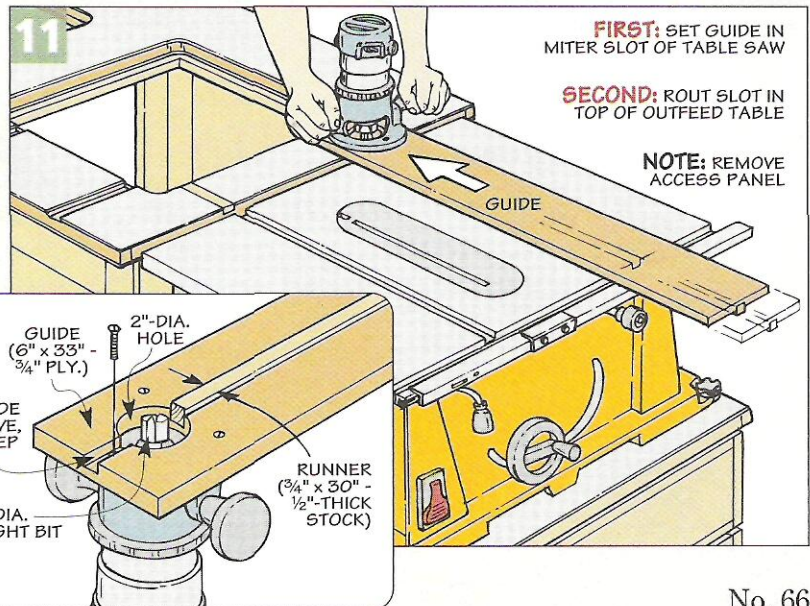

FIRST: SET GUIDE IN MITER SLOT OF TABLE SAW

SECOND: ROUT SLOT IN TOP OF OUTFEED TABLE

NOTE: REMOVE ACCESS PANEL

Fence

The last thing to add to the workstation is a fence for the router table, like the one you see in the photo at right.

As you can see in Figure 12, the fence has five parts: a base and face piece form the working part of the fence, and a pair of braces and a cover allow you to hook up the hose from the shop vacuum.

Base & Fence – I started on the fence by making the *base* (CC) from a long strip of 1/2" plywood and the *face* (DD) from a piece of 3/4" plywood, as you see in Figure 12.

You'll notice that the face has a narrow notch in it to provide clearance for the router bit. And the base has a wider notch that helps form an

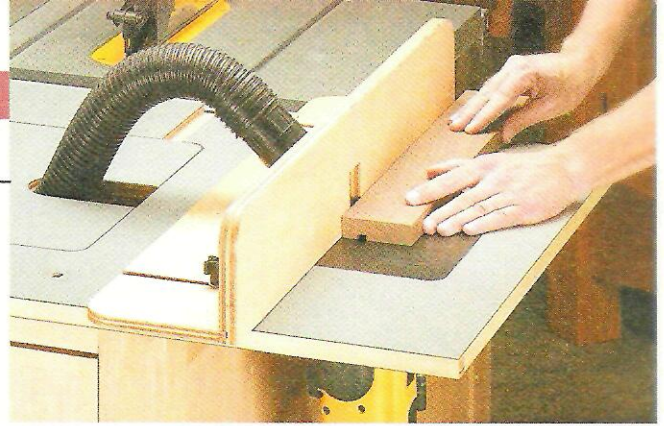

▲ Fence. Adding a fence to the router table adds versatility and allows you to hook up the hose from the shop vacuum.

opening for collecting dust and chips. A couple of narrow slots allow you to adjust the fence once it's attached to the top of the outfeed table.

Once the notches are cut, joining these pieces is just a matter of cutting a groove in the fence face to accept a tongue cut on the edge of the base (Figure 12a).

After the glue dried, I installed a pair of braces (EE) and a cover (FF) made from 1/2" plywood. A hole cut in the cover is sized to fit the end of the hose from the shop vacuum.

Inserts – All that's left to do to complete the installation of the fence is to install two sets of threaded inserts (Figure 12). The inserts allow you to attach the fence with a pair of studded knobs and washers.

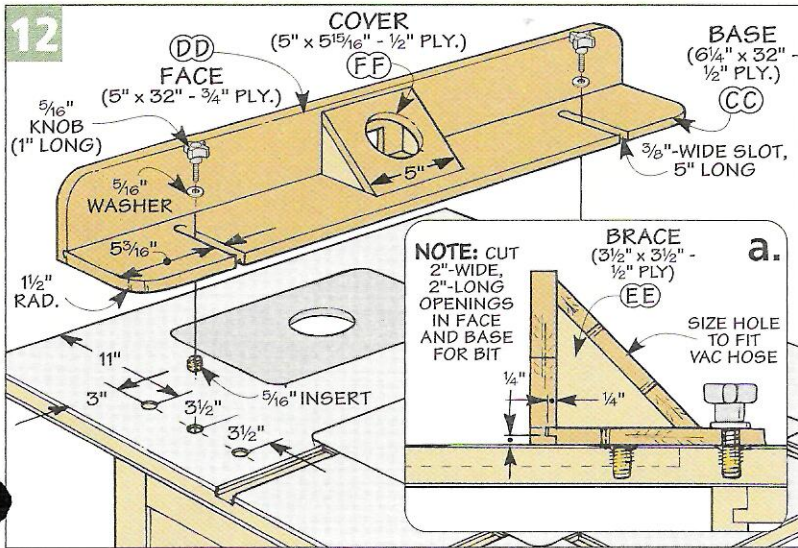

Electrical Hook-Up

Turning the shop vacuum on and off by reaching through the access plate opening is a hassle (or impossible with the router table fence in place). And going through the back of the outfeed cabinet isn't any better. To solve this problem, I added a switch (see photo).

Frame-Mounted Switch – Adding the switch isn't difficult. Just run a

short length of electrical cord (with a plug wired on one end) between a wall outlet and a switch/receptacle, as shown in the drawing below.

Once that's complete, just plug the power cord from the shop vacuum into the receptacle and you're all set. Note: You'll need to leave the switch on the shop vacuum in the "on" position.

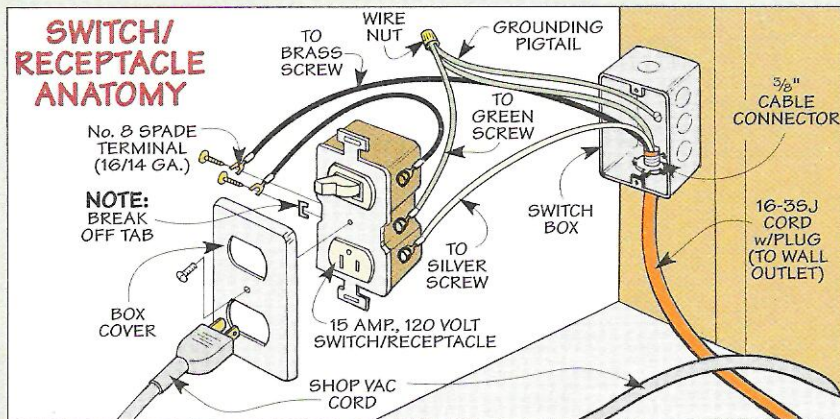
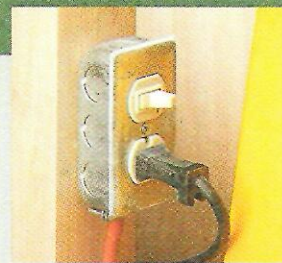

Electrical

- (1) 15 Amp., 120 Volt Switch/Receptacle
- (1) Switch Box
- (6) No. 8 Spade Terminals (16/14 ga.)
- (2) Grounding Pigtails (12 ga.)
- (1) 3/8" Cable Connector
- (1) Wire Nut Connector (Yellow)
- (2) #8 x 5/8" Panhead Sheet Metal Screws
- (1) Duplex Box Cover
- (1) 15 Amp., 125 Volt Plug (Grounded)
- 16-35J Electric Cord (14 feet)

*No measuring.
No marking.
And still get a
perfect fit
between your
insert and
router table.*

The biggest challenge to making any router table top is cutting an opening for the insert plate so that it fits perfectly. To answer that challenge when it came to the out-feed top for the Table Saw Workstation (page 20), I used a fool-proof method that doesn't require any tedious measuring or layout. Just a few common shop tools.

The nice thing about this method is you can use it to create an opening for any size or type of plate. Note: I used a mounting plate from Woodhaven. For more information on this mounting plate, refer to page 35.

Template & Guide Strips – This method works because you use the actual plate as a template for positioning a set of strips that guide a pattern bit when you're cutting the opening. (Most pattern bits will require 1"-thick strips.)

Locate Guide Strips – After making the guide strips, you're ready to locate the opening. To do this, use carpet tape to position one of the guide strips so it's parallel with one edge of where you'd like the plate located. Then use the insert plate to locate the other strips, as in Step 1.

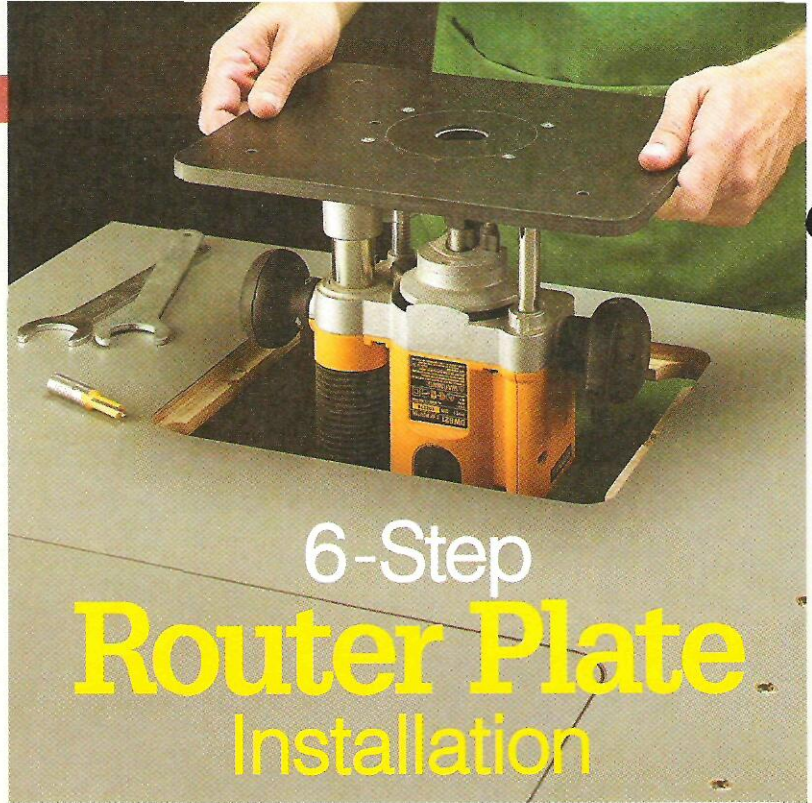

Cut Opening – Once you have the guide strips located, you're ready to cut the opening by following Steps 2 through 5. With the opening complete, all that's left to do to complete the installation is mount the router to the insert plate. If you take a look at Step 6, you'll see how to do this by using the existing base of your router.

Step 1

To locate the guide strips, use the insert plate as a template. Start by fastening one strip in place with carpet tape so it's parallel with one edge of where the plate is to be located. After positioning the plate along this strip so it's in its final location, you can "wrap" the plate with the remaining guide strips.

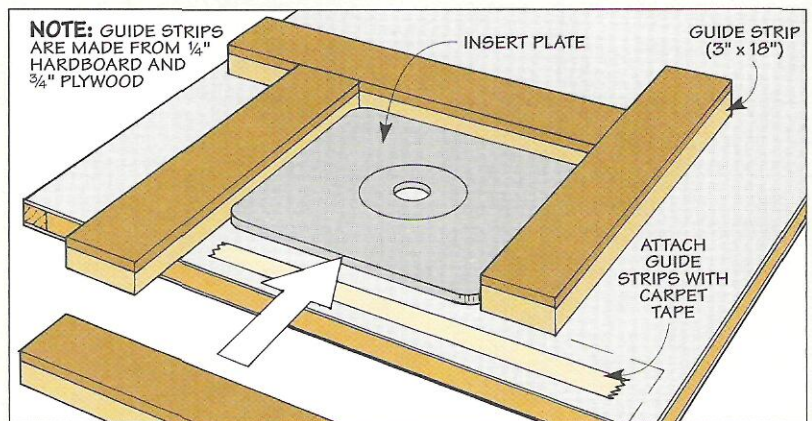

Step 2

To provide a starting point for the bit and create relief holes for dust, drill a 1 1/2"-dia. hole in each corner. A hole saw works great for this, but you'll need to wrap the body with masking tape to compensate for the set of the teeth, as you can see in detail 'a.' Once the teeth cut through the laminate, remove the tape and complete the hole.

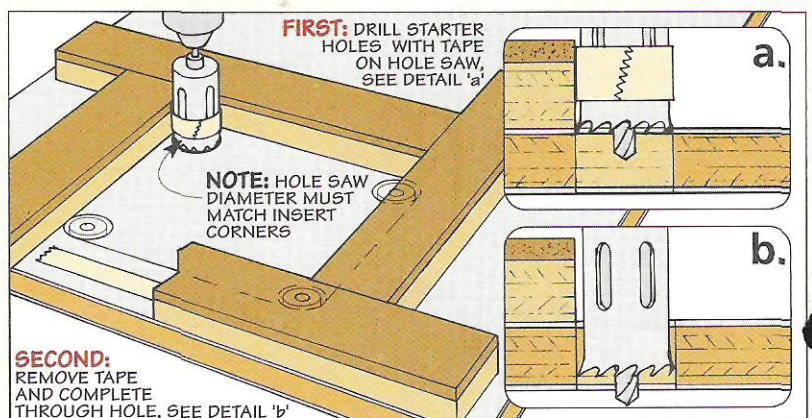

▲ For smooth cutting through laminate, apply a spray lubricant to the hole saw before drilling the hole.

Step 3

Before routing the lip, set the bit depth to match the exact thickness of the insert plate. To do this, mount the pattern bit in the router. Then place the insert plate on top of a guide strip. Set the router on the plate and lower the bit until it barely touches the top (see detail). If you rout too deep, see the margin for a quick fix. (For access plate, set bit for 1/4"-deep cut.)

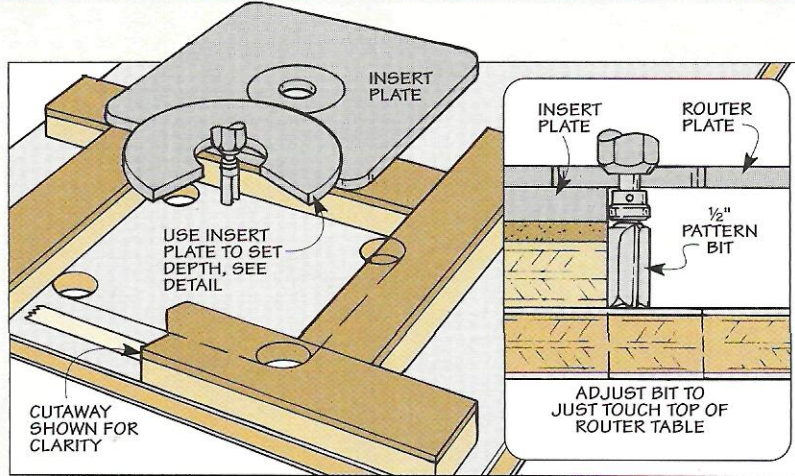

▲ **Pattern Bit.** The guide bearing at the top of a pattern bit makes it easy to cut a lip or opening in the center of a workpiece.

Step 4

At this point, set the bit into the opening in one of the corners so the router is resting on the guide strips. Then use the strips to guide the bearing on the bit (see detail) as you rout around the inside of the strips in a clockwise direction. Note: To maintain the radius in the corners, rout only to the edge of starter holes. (For access plate, make multiple 1/4"-deep passes through plate.)

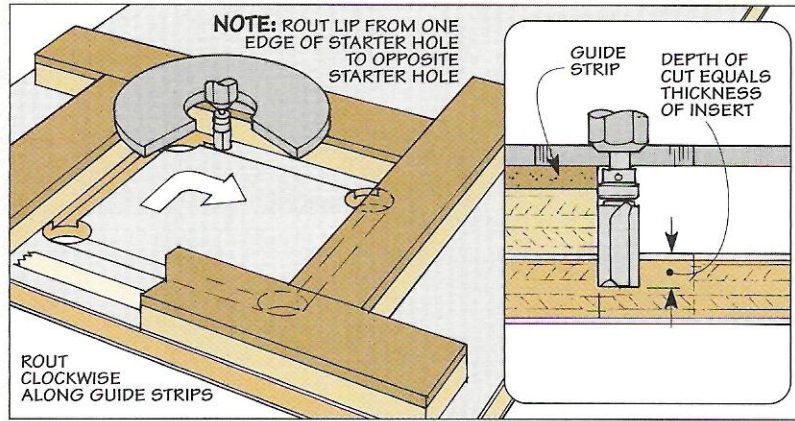

Step 5

Once the lip has been routed, you're ready to remove the waste. A jig saw makes quick work of this. All you need to do is follow the inside edge of the groove formed when you routed the lip (see detail). A little sanding will clean up the rough edges.

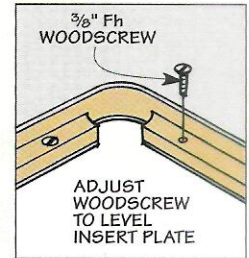
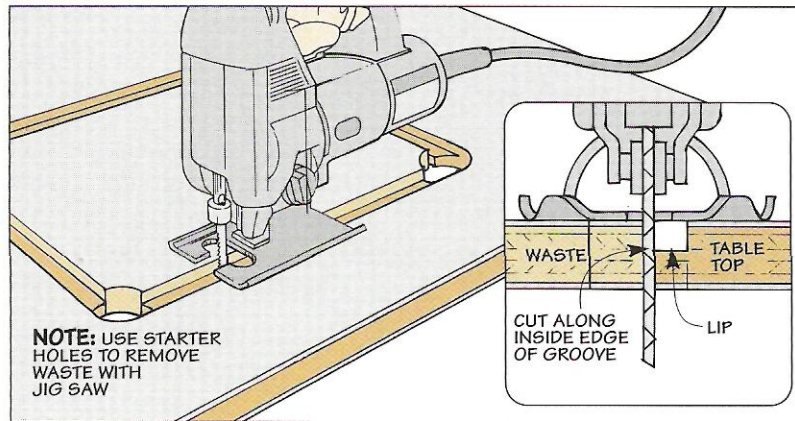

▲ **Levelers.** If the lip is routed too deep, installing a set of flathead screws allows you to raise the insert plate so it's flush with the top of the router table.

Step 6

All that's left is to attach the router to the mounting plate. This requires drilling holes for the machine screws that hold it in place. An easy way to locate the holes for the screws is to use the existing base on your router. (I used carpet tape to keep the base from shifting, like you see in the detail.)

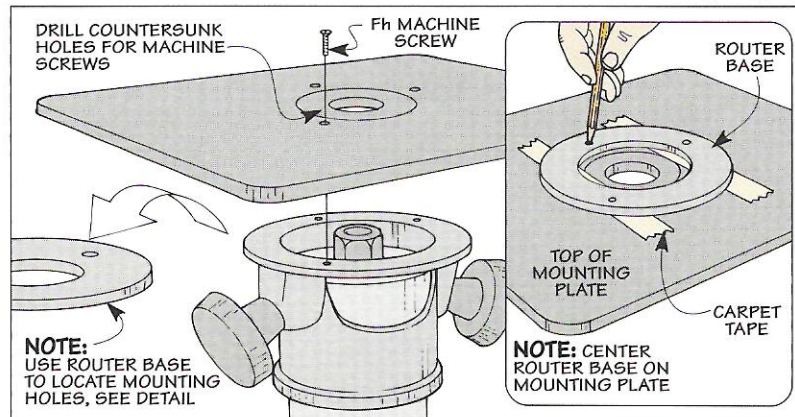

Tool Chest

This two-in-one tool is the perfect choice for fine-tuning cabinet joinery.

When it comes to wood-working tools, I'll admit to being something of a power tool junkie. But there's one hand tool that's been in my shop for about as long as I can remember. And I wouldn't want to be without it. That's my bullnose shoulder plane.

Shoulder planes are specialized planes designed for fine cabinet-work. The sides of the plane are milled square with the bottom. And the edges of the blade are flush with the sides. This makes the plane ideal for cleaning up rabbets or trimming the shoulder of a workpiece.

There are several types and sizes of shoulder planes. But the one I have is a rather small version made by Stanley. It's a model number "90." (Stanley uses numbers to designate all their planes.) It was handed down to me by my father, and it's older than I am. But this same plane is still being made by Stanley today.

Bullnose - This particular type of

shoulder plane is called a "bullnose" plane, and if you take a look at the photo above, you'll see why. The front of the plane is short and round, allowing the "nose" to work its way into tight areas that other planes just can't touch. But that's not the only reason I like this tool.

If you look at the inset photo above, you'll see another neat feature of this plane. By removing the front section of the plane, you can convert it from a bullnose plane into a chisel plane. This allows you to

work the blade all the way into an inside corner, which really comes in handy when cleaning up a rabbeted frame, for example. It's also great for removing dried glue from the inside corners of a carcass or paring down the protruding ends of a box joint or dovetail joint, just like you see in the margin photo shown at left.

Anatomy - There aren't many parts to a shoulder plane, as you can see in the drawing at left. The body of the plane consists of two sections — a bottom and a top. A large cap screw holds the sections together. The blade, or cutter, rests on a flat, ground seat in the bottom section and is held in place with a lever cap. A small adjustment block engages a series of slots in the underside of the cutter. Turning a screw behind the adjustment block moves the cutter forward or back and allows you to fine-tune the depth of cut.

One of the things that makes the Stanley No. 90 suitable for fine work

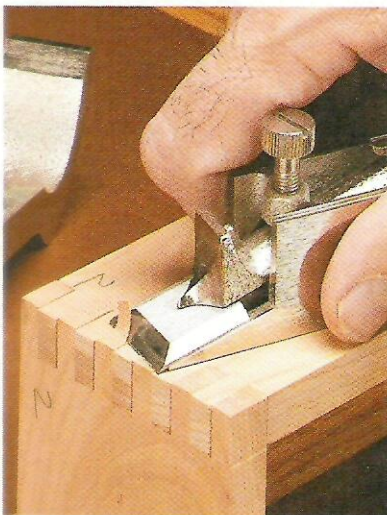
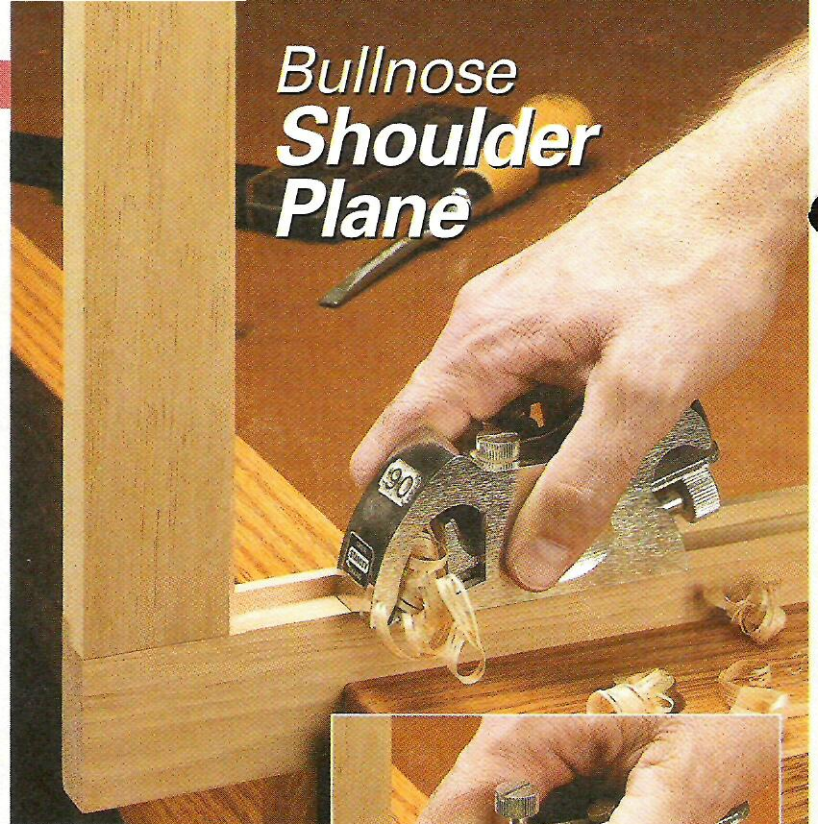

▲ **Chisel Plane.** With the top removed, this plane is quickly converted into a chisel plane. The low-angle blade cuts right through the end grain on this box joint.

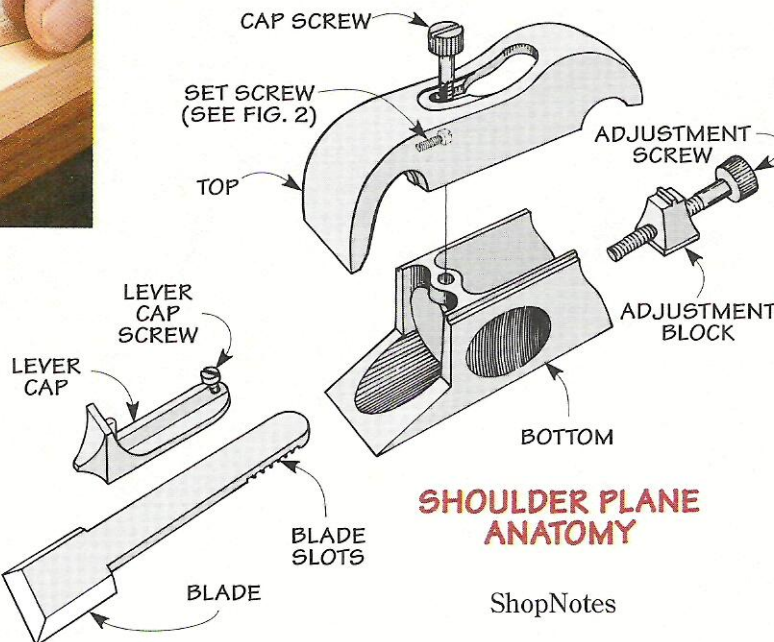

is that it has an adjustable throat. By loosening the large cap screw on the top of the plane, you can slide the top section forward or back to open or close the throat, depending on how thick of a shaving you are taking. Being able to adjust the throat opening is helpful to prevent the plane from tearing out the wood and getting clogged with shavings.

Inside the top section, there is a very small set screw. As you can see in Figure 1, this screw contacts the cap screw and serves as a stop for setting the throat opening. This way, you don't have to readjust the throat opening when switching back and forth from a chisel plane to a shoulder plane. You can adjust the stop with a small screwdriver, as shown in Figure 2.

Blade Angle – Another thing that makes this plane stand out from other bench planes is the angle of the blade. If you take a look at Figure 1, you can see that the blade is bedded at a fairly low angle (12°). This low-angle allows the cutter to slice through end grain with relative ease. The blade is also held down firmly by the lever cap, which helps to reduce chatter. A screw is used to tighten the lever cap and secure the blade in the body of the plane.

Feel – Part of the reason I like this plane so much is the way it feels.

At just a little over four inches long, it fits neatly in the palm of my hand. But don't let the compact size fool you. This plane has enough heft behind it to give it some authority, making it perfect for one-handed planing. And it's even got a couple of oval-shaped depressions milled into the sides for a good, comfortable grip.

Where this plane really excels (and what I use it for most often) is cleaning up a joint that I've cut on a table saw or router table. A lot of times when I cut a tenon or a rabbet on the table saw with a dado blade, the blade will leave behind small ridges. This plane is great for removing these ridges, especially in the corner of a shoulder (Figure 3). And since the sides of the plane are ground square with the bottom, you can use the plane on its side as well as on its sole, like you see in Figure 4.

Appearance – There's another thing that makes this plane one of my favorites. Although it doesn't have anything to do with performance, I really like the way this plane looks. It's well-proportioned and has nice, graceful curves. The cast iron

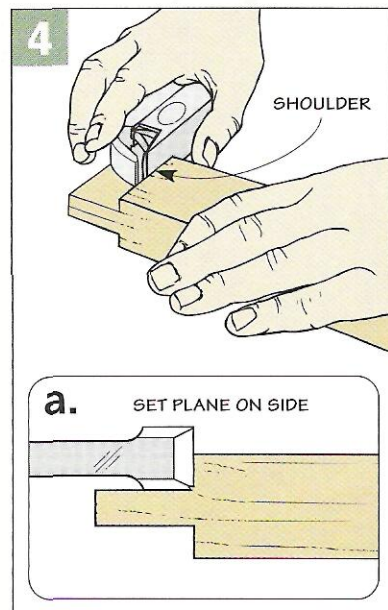
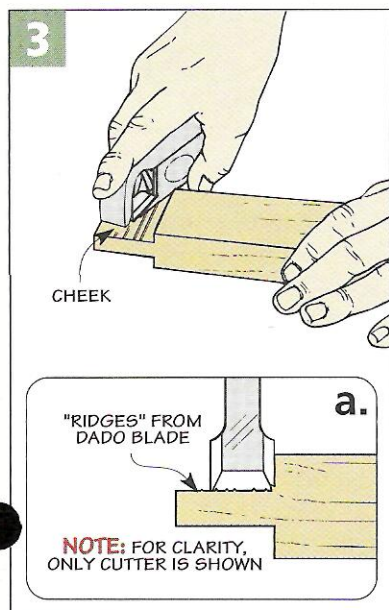
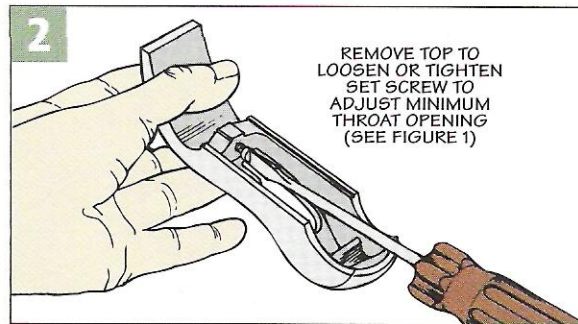
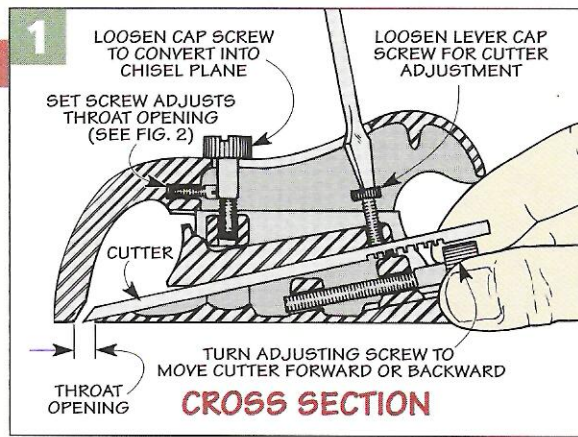

body is nickel-plated, making it both attractive and resistant to rust. And even though my plane has received so much use over the years that the nickel plating is worn through in some spots, it still works just as well as when it was new.

Sources – You probably won't find this plane at a typical hardware store or home center. But it is available from several different woodworking catalogs. (I've listed a few sources in the margin at right.) The cost is around \$80.

Stanley also makes a couple of other versions of this plane — a No. 92 and a No. 93 (see photo below). These planes look similar to the No. 90, but they have a longer front section. This extra length makes it a little easier to guide the plane, particularly at the beginning of a cut. But because of their size, these planes can't fit into tight spaces as easily as the No. 90.



Sources

- **Woodcraft**
www.woodcraft.com
800-225-1153
- **Garrett Wade**
www.garrettwade.com
800-221-2942
- **Lee Valley**
www.leevalley.com
800-871-8158
- **Highland Hardware**
highlandhardware.com
800-241-6748

◀ **Big Brothers.** In addition to the No. 90, Stanley also makes a couple of longer shoulder planes. These can also be converted into a chisel plane by removing the top.

Shop Talk

We've received several letters in the last month asking about the wood we used to build the workbench in *ShopNotes* Issue No. 65. And since we're featuring a matching storage project in this issue, I thought it would be the perfect time to talk about it.

For starters, there's nothing special about the species of wood we used — it's just red oak. The reason it looks different is we used red oak boards with a very straight *face-grain* pattern. To get this look, we selected *riftsawn* lumber.

Riftsawn — So what exactly is riftsawn lumber? If you take a close look at the *end* of a riftsawn board (the lower board in the margin photo), you'll notice that the growth rings are *angled* between 30° and 60° to the face of the board. This results in face grain that's straight and consistent.

Flatsawn — Most of the other boards you'll see, though, have

Riftsawn. ▲ *The consistent grain of riftsawn lumber doesn't draw attention to itself, so you can appreciate the design and craftsmanship of the cabinets.*

Lumber Selection — Flatsawn vs. Riftsawn

arched growth rings that are 30° (or less) to the face of the board, like the top board shown in the margin. In many cases, especially in wide boards, the rings will often be parallel to the face. This results in wide, arched face-grain patterns.

Does it Really Matter? — You might be asking yourself how much difference this could really make when it comes to building a project. A glance at the photos at left and above, and the answer is fairly obvious.

When flatsawn lumber is used on a large project, the grain grabs your attention and takes away from the look of a well-designed project.

Does that mean you should always use riftsawn lumber? Of course not. But whenever you want to play down the grain, like in the photo above, it's something you should consider.

Besides its looks, riftsawn lumber has another benefit.

It's more stable. So parts of the project like doors are more likely to stay flat and straight, instead of warping and causing a problem with the fit. And drawer fronts are less likely to cup or twist.

Cost & Availability — Now you might assume that riftsawn lumber will cost more. But if you spend a little extra time sorting through the lumber stack, you can probably find all the riftsawn lumber you need. That's because you'll almost always find some in the same stack as the flatsawn lumber.

Unfortunately, that's not always the case when you need riftsawn *plywood*. Unless the veneer is cut just right, you're likely to have to special order riftsawn plywood. Still, in the long run it's worth it to end up with a better-looking project.

So the next time you head for the store, select your lumber (and plywood) with the grain in mind. It might take a little more work up front, but it's sure to make your project a standout once it's built. 🛠️

▼ **FLATSAWN**
(note end grain)

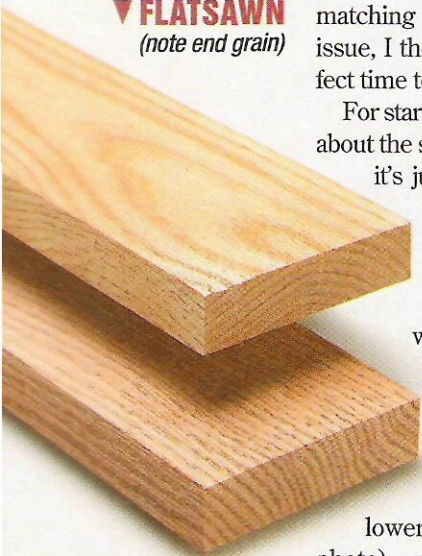

▲ **RIFTSAWN**
(note end grain)



Flatsawn. ► *Flatsawn lumber will have sections of straight grain along with some wide, arched grain patterns. This inconsistency can detract from the look of a project.*

Sources

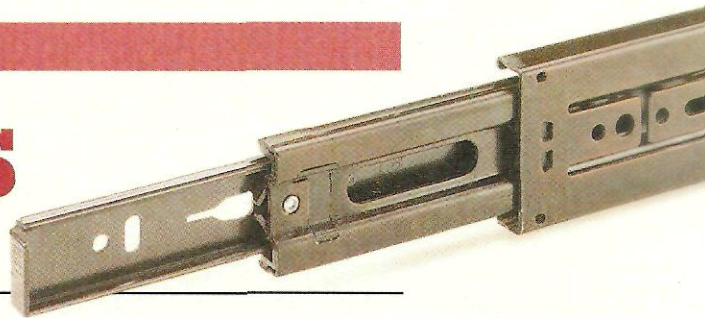

Storage Cabinet Hardware

Although there isn't much hardware required to build the Convertible Shop Storage Cabinets (page 10), there are a couple of items you'll need.

Knobs - To give the cabinet doors and drawers a unique look, we used 1 1/8"-square knobs from *Lee Valley* (01G62.20). The knob has a

post mounted with two screws, so you don't have to worry about it rotating during use.

Slides - And to make it easy to reach the entire contents of the drawers, they ride on full-extension, metal slides. This type of slide is available in a variety of lengths and finishes.

(We used 20"-long black slides on the Convertible Shop Storage Cabinets.)

Drawer slides are available from most woodworking stores and the sources listed at right.

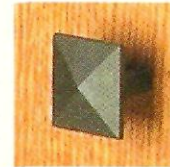

MAIL ORDER SOURCES

Lee Valley
800-871-8158
www.leevalley.com
Casters, Drawer Slides, Knobs

Rockler
800-279-4441
www.rockler.com
Casters, Drawer Slides

Woodcraft
800-225-1153
www.woodcraft.com
Casters, Drawer Slides

Woodhaven
800-344-6657
www.woodhaven.com
Router Plates

Woodsmith Store
800-835-5084
Casters, Router Plates

Router Plate Insert

You can use just about any type of router plate for the Table Saw Workstation on page 20. But one of the best we've run across is one made by *Woodhaven*.

For starters, the 9 1/4" x 11 3/4" plate is a 3/8"-thick piece of phenolic. So it's solid and stiff enough for mounting a heavy-duty router. (There's also a smaller version that's sized 7 3/4" x 10 1/4".)

Inserts - Then to accommodate different size bits, you get a set of three inserts that snap securely in place — an 1 3/16"-dia. bushing/bit hole, a 2"-dia. bit hole, and a blank for customizing. (With no inserts

installed the bit hole has a diameter of 3 5/8".

One last thing. Starting a workpiece into a router bit with a bearing can be tricky. To help with this, you also get a starting pin as part of the "kit" — a nice extra.

Cost - The large *Woodhaven* router plate costs around \$55. (The

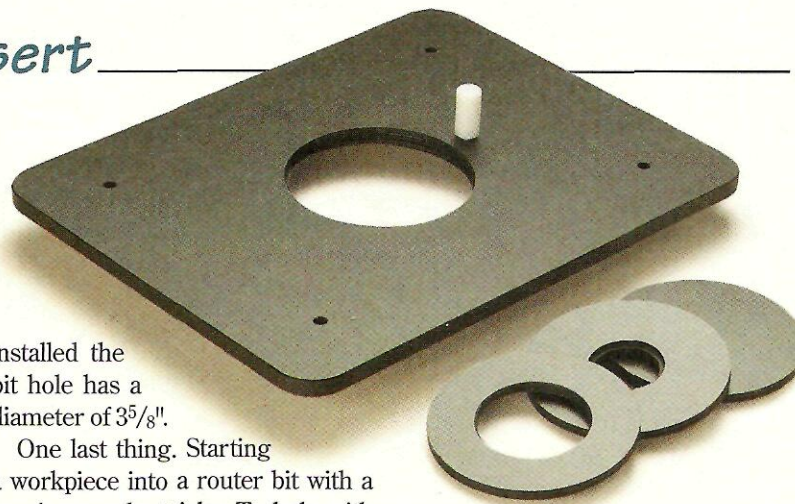

small one sells for \$50.) You can order the large plate from the *Woodsmith Store* or both plates are available from *Woodhaven* (see margin).

Heavy-Duty Casters

The locking swivel caster shown below was used on both the Shop Storage Cabinets (page 10) and the Table Saw Workstation (page 20) to make them easy to roll around.



Double-Locking - But just because each project is mobile doesn't mean it isn't rock-solid during use. That's because the lever on these casters locks both the wheel and swivel action. And since each caster is rated for 300 lbs., they're heavy-duty enough to support just about any shop (or home) project around.

Cost - We used 3" casters on the Workstation and 4" casters on the Storage Cabinets, but 5" casters are also available. The casters range in cost from \$16 (3") to \$20 (5"). These casters (or similar types) are available from the sources listed at right.

ShopNotes on the web

- "Online Extras" - Plans, Patterns, & More
- Over 100 Woodworking Tips Online
- Forums for Woodworking, Tools, & Classifieds
- Visit Our Woodworking Shop Tours Gallery
- Project Plans You Can Download
- Catalog of Project Kits, Tools, Jigs, & Plans
- Links to Other Woodworking Sites
- Order *ShopNotes* & *Woodsmith* Back Issues

Online Customer Service

Click on Subscriber Services at www.shopnotes.com

- Access your account status
- Change your mailing or email address
- Pay your bill
- Renew your subscription
- Tell us if you've missed an issue
- Find out if your payment has been received

www.shopnotes.com

Scenes from the Shop



Whether you build these Shop Storage Cabinets to fit under a workbench or as a stand-alone unit (see page 10), you'll have ample storage right where you need it. Detailed plans begin on page 10.



▲ The outfeed table of this Table Saw Workstation makes it easy to rip long workpieces with a portable table saw. Step-by-step instructions begin on page 20.

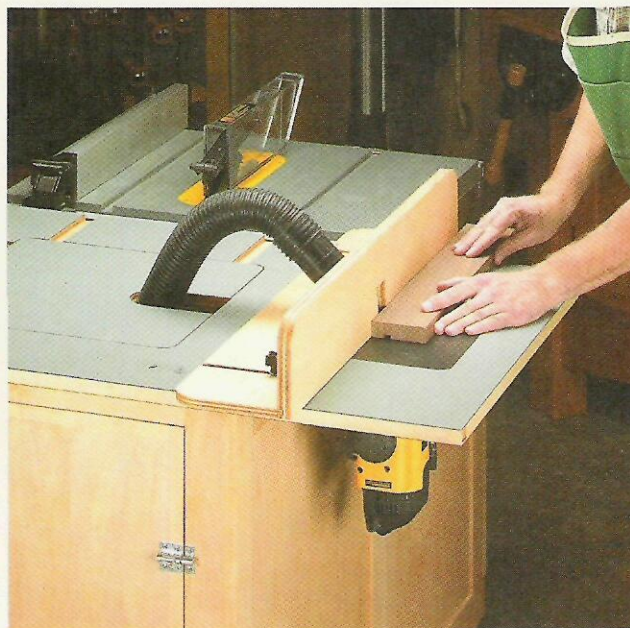

▲ The outfeed table can also be positioned to the side for routing operations. And an opening in the access plate makes it a snap to hook up a shop vacuum to the fence.



ShopNotes[®] Cutting Diagram

Table Saw Workstation

Materials

A Side Rails (4)	$\frac{3}{4}$ x 2 $\frac{1}{2}$ - 17 $\frac{1}{2}$	Q Side Stiles (4)	$\frac{3}{4}$ x 2 $\frac{1}{2}$ - 30
B Side Stiles (4)	$\frac{3}{4}$ x 2 $\frac{1}{2}$ - 16 $\frac{7}{8}$	R Side Panels (2)	22 $\frac{1}{2}$ x 25 $\frac{1}{2}$ - $\frac{1}{2}$ Ply.
C Side Panels (2)	17 $\frac{1}{2}$ x 12 $\frac{3}{8}$ - $\frac{1}{2}$ Ply.	S Subtop/Bottom (1)	26 x 26 - $\frac{3}{4}$ Ply.
D Back Rails (2)	$\frac{3}{4}$ x 2 $\frac{1}{2}$ - 21 $\frac{5}{8}$	T Front/Back Stiles (4)	$\frac{3}{4}$ x 2 $\frac{1}{2}$ - 30
E Back Stiles (2)	$\frac{3}{4}$ x 2 $\frac{1}{2}$ - 16 $\frac{7}{8}$	U Front/Back Rails (3)	$\frac{3}{4}$ x 1 $\frac{1}{2}$ - 21 $\frac{1}{8}$
F Back Panel (1)	21 $\frac{5}{8}$ x 12 $\frac{3}{8}$ - $\frac{1}{2}$ Ply.	Y Door (1)	19 $\frac{3}{8}$ x 26 $\frac{7}{8}$ - $\frac{3}{4}$ Ply.
G Subtop/Bottom (2)	21 $\frac{1}{2}$ x 26 - $\frac{3}{4}$ Ply.	W Edging	$\frac{3}{4}$ x $\frac{3}{4}$ - 9 Ln. Ft.
H Lower Rail (1)	$\frac{3}{4}$ x 2 $\frac{1}{2}$ - 27	X Door Stop (1)	$\frac{3}{4}$ x 2 $\frac{3}{4}$ - 28 $\frac{1}{2}$
I Top (1)	21 $\frac{3}{4}$ x 26 $\frac{1}{2}$ - $\frac{3}{4}$ Ply.	Y Outfeed Top (1)	26 $\frac{1}{2}$ x 38 $\frac{1}{2}$ - $\frac{3}{4}$ Ply.
J Edging	$\frac{3}{4}$ x $\frac{3}{4}$ - 9 Ln. Ft.	Z Edging	$\frac{3}{4}$ x $\frac{3}{4}$ - 12 Ln. Ft.
K Fronts/Backs (4)	$\frac{3}{4}$ x 5 $\frac{1}{2}$ - 24	AA Access Plate (1)	16 x 16 - $\frac{3}{4}$ Ply.
L Sides (4)	$\frac{3}{4}$ x 5 $\frac{1}{2}$ - 20	BB Pads (4)	(Custom size to fit tablesaw)
M Bottoms (2)	19 $\frac{1}{2}$ x 24 - $\frac{1}{4}$ Ply.	CC Base	6 $\frac{1}{4}$ x 32 - $\frac{3}{4}$ Ply.
N False Fronts (2)	5 $\frac{1}{2}$ x 25 $\frac{1}{2}$ - $\frac{3}{4}$ Ply.	DD Face	5 x 32 - $\frac{1}{2}$ Ply.
O Edging	$\frac{3}{4}$ x $\frac{3}{4}$ - 11 Ln. Ft.	EE Braces	3 $\frac{1}{2}$ x 3 $\frac{1}{2}$ - $\frac{1}{2}$ Ply.
P Side Rails (4)	$\frac{3}{4}$ x 2 $\frac{1}{2}$ - 22 $\frac{1}{2}$	FF Cover	5 x 5 $\frac{15}{16}$ - $\frac{1}{2}$ Ply.

$\frac{3}{4}$ " x 6" x 96"

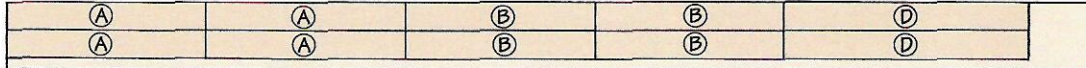

$\frac{3}{4}$ " x 6" x 96"

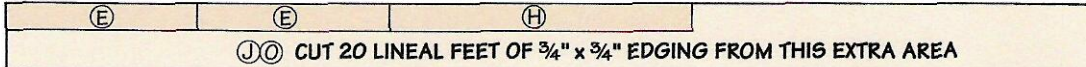

$\frac{1}{2}$ " x 6" x 96" (TWO BOARDS)



$\frac{3}{4}$ " x 6" x 96"

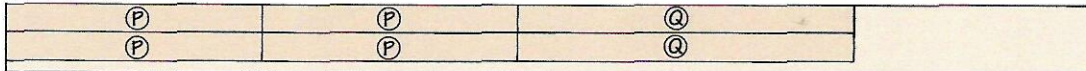

$\frac{3}{4}$ " x 6" x 96"

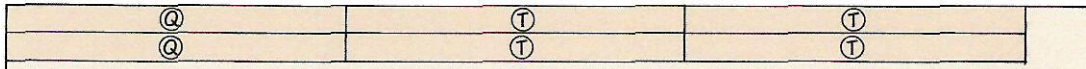

$\frac{3}{4}$ " x 8" x 96"

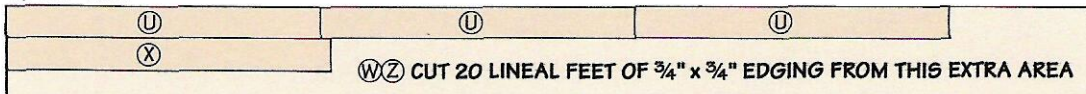

48" x 96" - 1/2" PLYWOOD

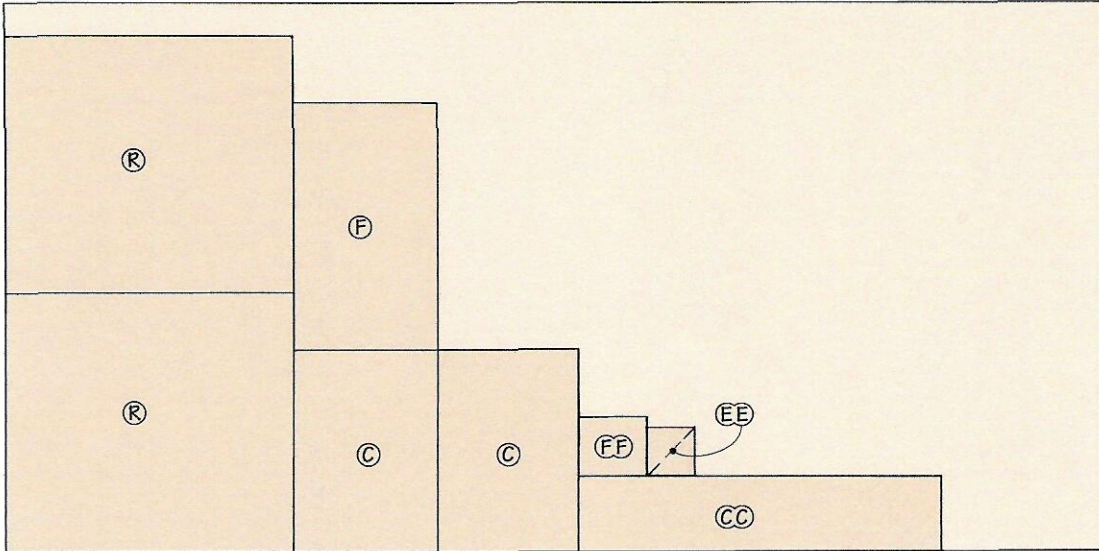

48" x 96" - 3/4" PLYWOOD

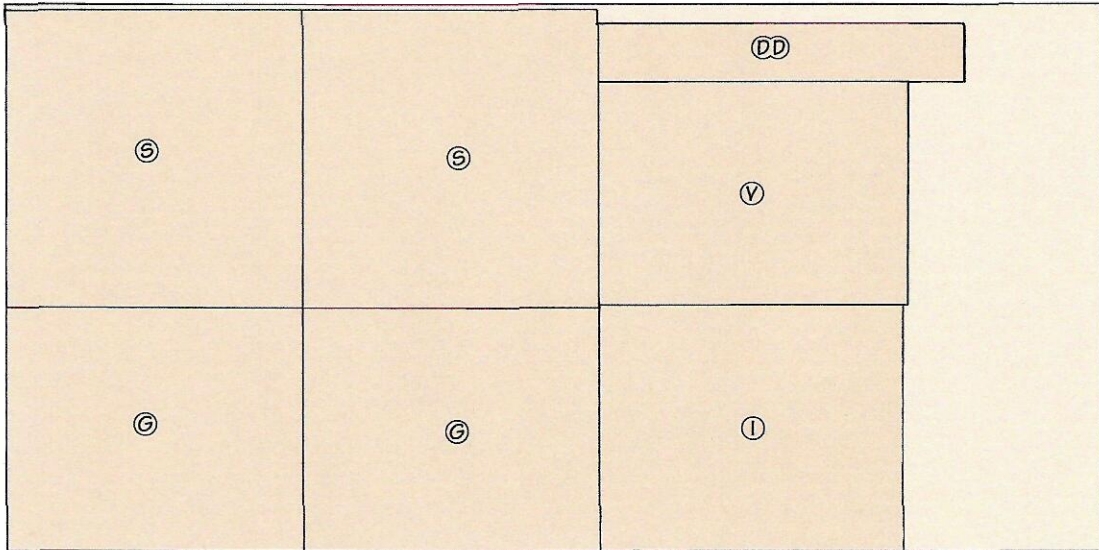

48" x 96" - 3/4" PLYWOOD

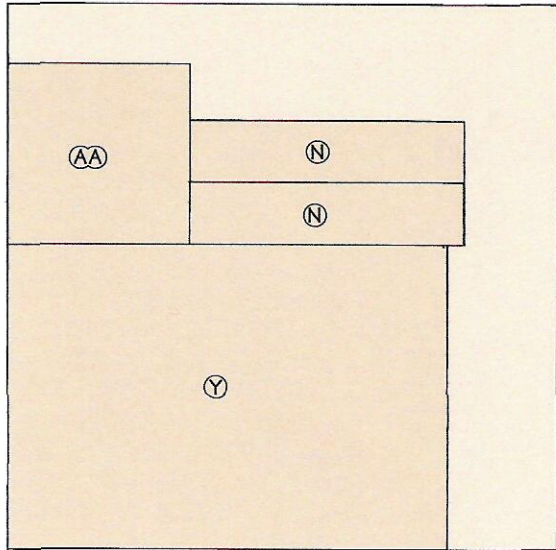

24" x 48" - 1/4" PLYWOOD

