

**#1 Router -  
BETTER THAN EVER**

**THE SECRETS TO SELECTING JIG SAW BLADES**

# ShopNotes<sup>®</sup>

Vol. 12

Issue 68

**Our ALL-NEW Router Jig  
MAKES MORTISES  
EASY AS 1·2·3**

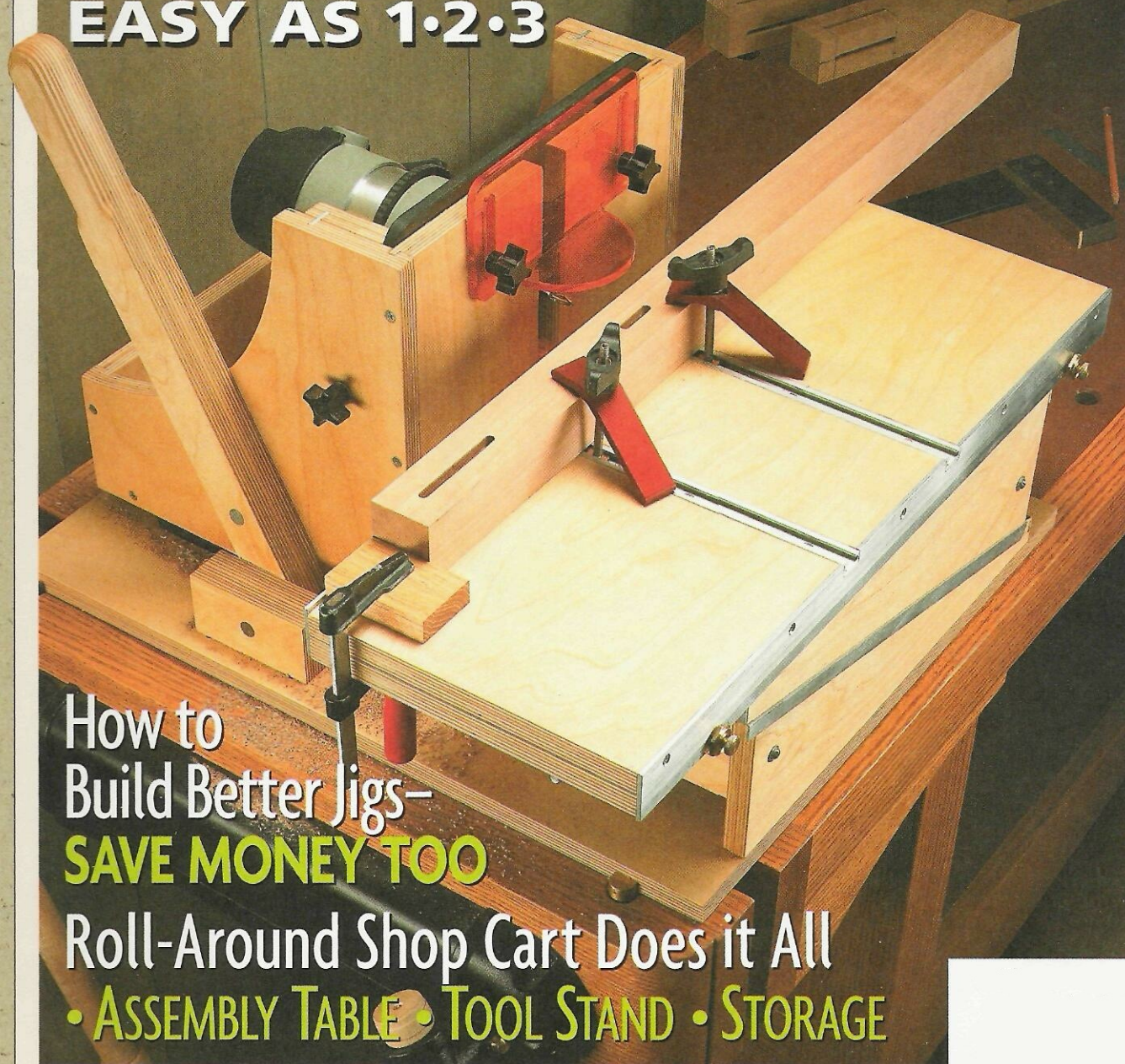

How to  
Build Better Jigs—  
**SAVE MONEY TOO**

Roll-Around Shop Cart Does it All

• **ASSEMBLY TABLE** • **TOOL STAND** • **STORAGE**



# ShopNotes®

Issue 68

March 2003

**PUBLISHER** Donald B. Peschke

**EDITOR** Terry J. Strohman

**ASSOCIATE EDITORS** Bryan Nelson

Vincent Ancona

**CONTRIBUTING EDITOR** Phil Huber

**ART DIRECTOR** Cary Christensen

**SR. GRAPHIC DESIGNER** Kurt Schultz

**SENIOR ILLUSTRATORS** Roger Reiland  
Mark Higdon

## CREATIVE RESOURCES

*Creative Director:* Ted Kralicek • *Sr. Project Designers:* Ken Munkel, Kent Welsh, Ryan Mimick, Chris Fitch • *Shop Craftsmen:* Steve Curtis, Steve Johnson • *Sr. Photographer:* Crayola England

## SPECIAL PUBLICATIONS

*Corp. V.P.:* Douglas L. Hicks • *Art Director:* Douglas A. Flint • *Sr. Graphic Designer:* Chris Glowacki • *Graphic Designers:* Vu Nguyen, Jonathan Eike • *Senior Editor:* Craig Ruegsegger • *Asst. Editor:* Joel A. Hess • *Editorial Intern:* Cindy Thurmond

## CIRCULATION

*Subscriber Services Director:* Sandy Baum • *New Business Dir.:* Wayde J. Klingbeil • *Circulation Marketing Analysts:* Kris Schlemmer, Paula M. DeMatteis • *Renewal Manager:* Paige Rogers • *Sr. Graphic Designers:* Mark Hayes, Robin Friend • *Billing & Collections Mgr.:* Rebecca Cunningham • *Promotion Analyst:* Patrick Walsh

## CORPORATE SERVICES

*V.P. of Finance:* Mary R. Scheve • *Controller:* Robin K. Hutchinson • *Sr. Acct.:* Laura J. Thomas • *Accts. Payable:* Mary J. Schultz • *Accts. Receivable:* Margo Petrus • *Prod. Dir.:* George Chmielarz • *Electronic Pub. Dir.:* Douglas M. Lidster • *System Admin.:* Cris Schwanebeck • *P.C. Maint. Tech.:* Robert D. Cook • *Pre-Press Image Specialists:* Troy Clark, Minniette Johnson • *New Media Mgr.:* Gordon C. Gaippe • *Multimedia Art Dir.:* Eugene Pedersen • *Web Server Admin.:* Carol Schoeppler • *Web Content Mgrs.:* David Briggs, Sue M. Moe • *Web Designer:* Kara Blessing • *Prof. Dev. Dir.:* Michal Sigel • *H. R. Asst.:* Kirsten Koele • *Office Mgr.:* Natalie Lonsdale • *Facilities Mgr.:* Kurt Johnson • *Admin. Asst.:* Jeanne Johnson • *Mail Room Clerk:* Lou Webber

## MAIL ORDER

*Operations Director:* Bob Baker • *Customer Service Mgr.:* Jennie Enos • *Warehouse Supr.:* Nancy Johnson • *Buyer:* Linda Jones • *Admin. Asst.:* Nancy Downey • *Sr. Cust. Serv. Reps.:* Tammy Truckenbrod, Anna Cox, Deborah Rich, April Revell • *Cust. Serv. Reps.:* Valerie Jo Riley, Kim Harlan • *Warehouse:* Sylvia Carey

## WOODSMITH STORE

*Manager:* Dave Larson • *Merchandise Marketing Mgr.:* John Sibereil • *Asst. Mgr.:* Tim Thelen • *Sales Staff:* Wendell Stone, Larry Morrison, Gregory Kauzlarich, Mark Johnson, Brian McCallum • *Office Mgr.:* Vicki Edwards

ShopNotes® (ISSN 1062-9696) is published bimonthly (Jan., March, May, July, Sept., Nov.) by August Home Publishing, 2200 Grand, Des Moines, IA 50312.

ShopNotes® is a registered trademark of August Home Publishing © Copyright 2003 by August Home Publishing. All rights reserved. Subscriptions: Single copy: \$4.95. One year subscription (6 issues), \$27.95. Canada/International add \$10 per year; U.S. funds.

Periodicals Postage Paid at Des Moines, IA and at additional mailing offices.

Postmaster: Send change of address to ShopNotes, P.O. Box 37103, Boone, IA 50037-2103.

Subscription Questions? Write to: ShopNotes Customer Service, P.O. Box 842, Des Moines, IA 50304-9961. Or call 1-800-333-5854, 8:00 am to 5:00 pm, Central Time, weekdays. FAX 515-283-0447

Email: ShopNotes@shopnotes.com

Internet: http://www.shopnotes.com

PRINTED IN U.S.A.

# Cutoffs

**C**lamp. Plunge. Slide. That's all there is to it. The first time I used the mortising machine featured in this issue I couldn't believe how quick, easy, and accurate it was.

All I had to do was lock the workpiece in place with a couple of hold-downs. Then I grabbed the handle and pulled. The carriage that held the router slid forward almost effortlessly, plunging the router bit into the workpiece. At that point, I simply moved the sliding table side to side, slicing the mortise to length. Before I knew it, I had a perfect, smooth-sided mortise. Just that quick and easy.

But that's just part of the story. The mortise that took less than a minute to make was actually weeks in the making.

The biggest challenge with a project like the mortising machine is movement. Anytime you add a moving part to a project you increase its complexity — and the potential for inaccuracy.

Now dealing with movement in one direction can be tricky enough. But with the mortising machine we had to deal with movement in *three*

directions: up and down, side to side, and back and forth. At the same time, it had to be dead-on accurate.

The solution we came up with involves mounting the router horizontally. The workpiece rests on a sliding table that sits on top of a pair of opposing wedges. These wedges allow the table to be raised and lowered very precisely.

But arriving at the basic design of the mortising machine was only half the battle. The next step was to find the right hardware to make it all work. What we decided on was nothing too exotic: a pair of drawer slides, some aluminum channel, a few springs, and a couple handfuls of assorted knobs and fasteners. But it was just what we needed to get things moving.

Even if you don't build the mortising machine, choosing the right materials and hardware for your jigs is always important. That's why you might want to take a look at the article on page 22.

Terry

## Be included, as a part of the Woodworking Shop Tours

On the Web

Visit other ShopNotes subscribers' workshops and see photos of the shop projects they've built. It's all online at Woodworking Shop Tours on the ShopNotes web site:

[www.ShopNotes.com](http://www.ShopNotes.com)

We want you to be part of our shop tours! To submit photos of your favorite ShopNotes projects or views of your shop, just follow the instructions you'll find on our web site.



# Contents

## Features

### Benchtop Tool Organizer \_\_\_\_\_ 6

*Does a cluttered workbench keep you from doing your best work? Not anymore. With our tool organizer you'll have all your tools within easy reach — and a cleaner benchtop too.*

### Jig Saw Blades \_\_\_\_\_ 10

*Don't give jig saw blades a lot of thought? Well, maybe you should. We'll show you how to pick the right blade for the job.*

### Horizontal Mortising Machine \_\_\_\_\_ 12

*Our all-new, shop-built mortising machine lets you rout perfect mortises every time. A table that moves in two directions and a carriage that slides in and out allow you to set up and cut a mortise in less than a minute.*

### Materials & Hardware for Shop Jigs \_\_\_\_\_ 22

*A shop-made jig can make your woodworking easier, faster, and more precise. Learn what materials and hardware we use day in and day out when we build our jigs.*

### Roll-Around Shop Cart \_\_\_\_\_ 26

*Moving a pile of workpieces around the shop can be a hassle. Or if you're working at one tool, it's nice to have an extra worksurface to help keep everything organized. With our roll-around shop cart, both problems are solved.*

## Departments

### Readers' Tips \_\_\_\_\_ 4

*Shop-tested tips to solve common woodworking problems.*

### Shop Talk \_\_\_\_\_ 32

*For only \$20 you can dramatically improve the accuracy of your shop tools. Here's what you need to know about dial indicators.*

### Tool Chest \_\_\_\_\_ 34

*Porter Cable's 690 router has been a workhorse in our shop for years. Find out what makes their updated model an even better choice for your workshop.*

### Sources \_\_\_\_\_ 35

*Mail-order sources and supplies to help you complete the projects featured in this issue.*

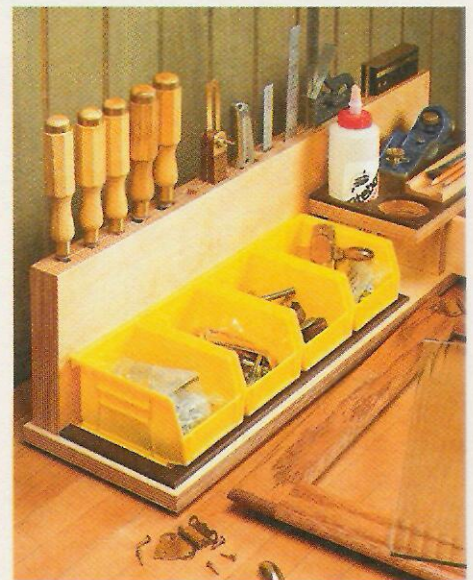

Benchtop Tool Organizer page 6

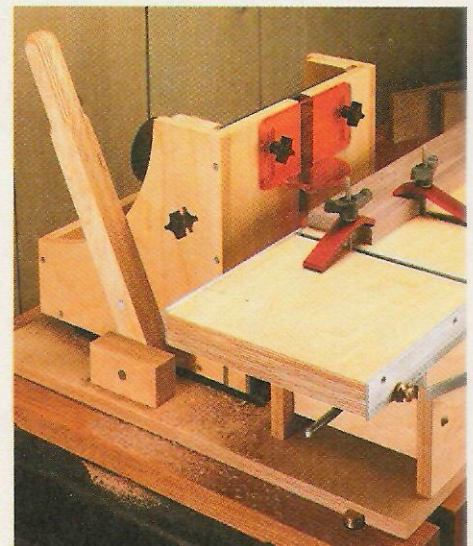

Mortising Machine page 12

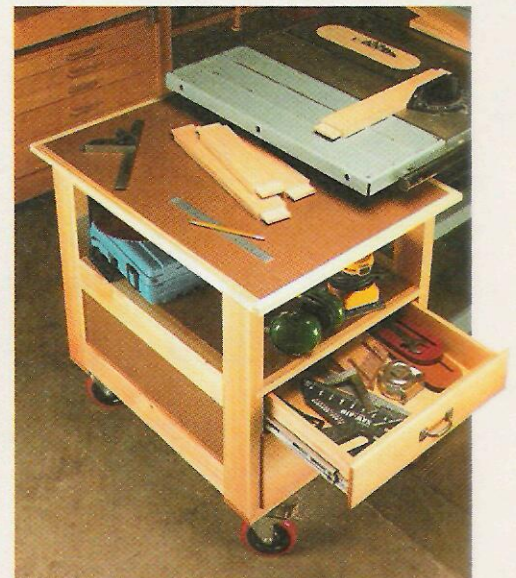

Roll-Around Cart page 26

# Readers' Tips

## Plywood Scoring Tool

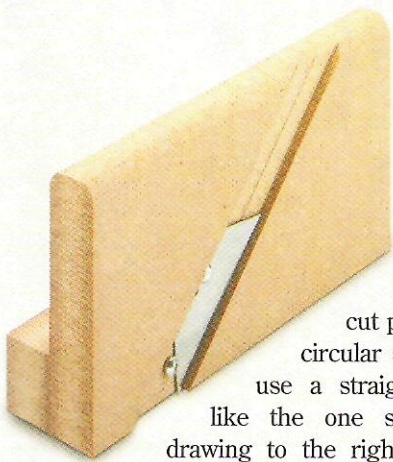

■ When I cut plywood with a circular saw, I typically use a straightedge guide like the one shown in the drawing to the right (featured in issue No. 55). The hardboard bottom prevents one side from chipping out on the finished edge. The problem is the waste side. That side usually splinters and can be unusable for other projects. The best way to get around this is to score the top veneer of the plywood before making the cut. To do this, I made the scoring tool shown in the photo.

The tool is nothing more than a scrap of MDF with a utility knife blade mounted in a shallow recess, as in detail 'a.' The blade is attached

with two roundhead screws so that just the tip is exposed. And to keep the tool square and upright, I added a short support piece. The depth of the recess is equal to the width of a

saw blade (detail 'b'). When you pull it along the straightedge, the tool scores the waste side of the cut.

*Fred DeHoff  
Portland, Indiana*

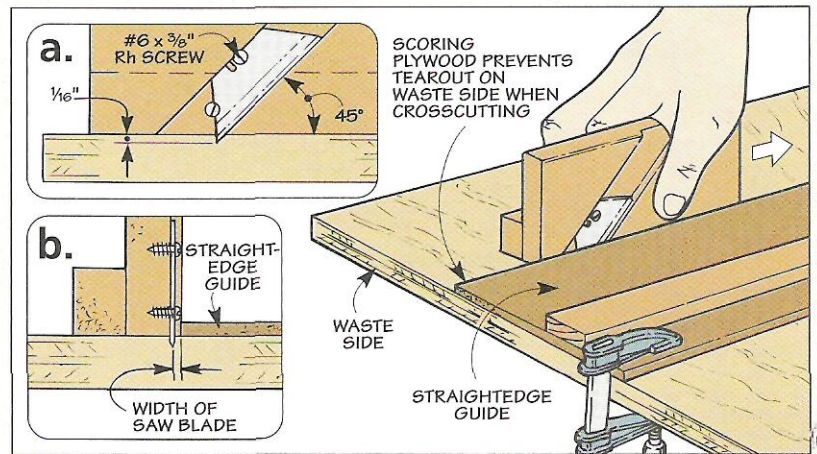

## Auxiliary Fence Support

■ There are many times when I need to attach a long auxiliary fence to the miter gauge on my table saw for extra support. But the weight of the auxiliary fence causes the miter

gauge to tilt and catch on the corner of the saw table. Besides being annoying, it can cause an uneven cut. To get around this problem, I added an extension arm to the edge of the

table. As you can see in the drawing, it's nothing more than a hardwood guide that supports the miter gauge fence and keeps it from tipping when it's unsupported by the saw table.

To make one, begin by making a T-slot from three pieces of hardwood, as in detail 'a.' Next cut a thin strip of wood to fit inside the slot and act as a rail for the extension arm.

I attached the rail to the edge of the saw table with machine screws and nylon bushings. What you're looking for is to have the extension arm flush with the table. And to get a smooth, sliding action, you can rub some wax on the rail.

Finally to keep the arm from being pushed along by the weight of the auxiliary miter fence, I installed a threaded insert in the arm and then a thumb screw to lock it in place.

*Eric Johnson  
Edgewood, Kentucky*

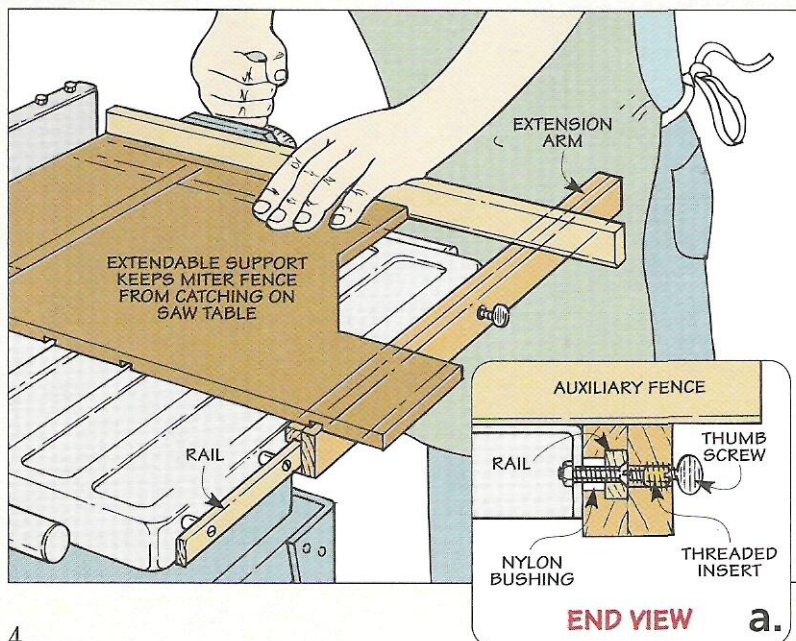

### Free Tips ON THE WEB

Get more wood-working tips **free**.

Visit us on the Web at **ShopNotes.com**

Sign up to receive a free shop tip by email every week.

## Quick Tips

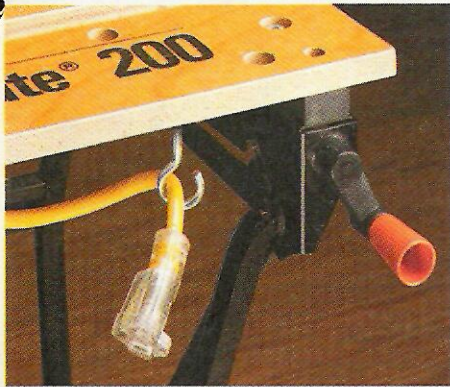

▲ Dana Craig of Norwood, MA keeps an extension cord within arm's reach by slipping the cord through a partially opened eyebolt attached to his Workmate.

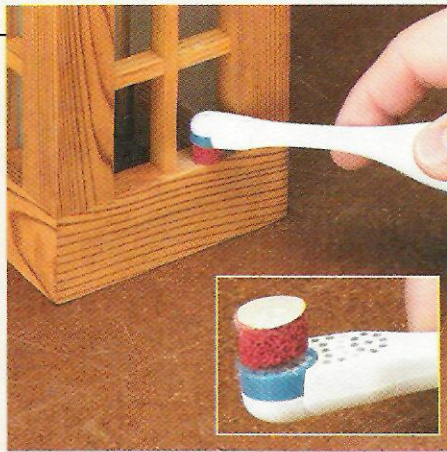

▲ For sanding in tight places, Chuck Hall of Florence, MT cut the bristles off a battery-powered toothbrush and glued on a piece of foam and sandpaper.

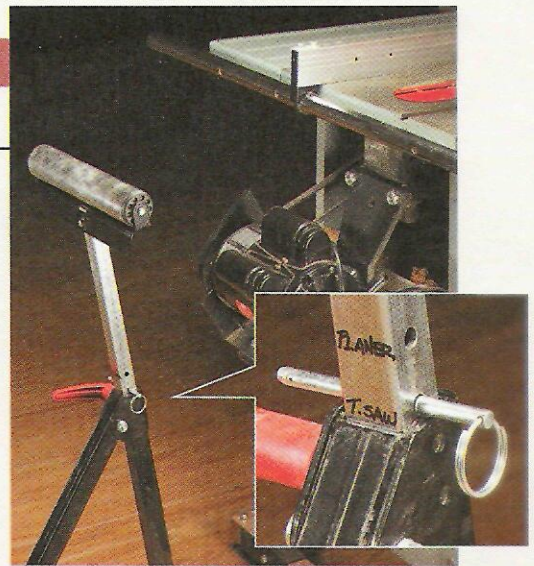

▲ Mark McConnel of Costa Mesa, CA quickly sets the height of his outfeed rollers by drilling holes in the riser and locking it in place with a hitch pin.

## Over-the-Bench Tool Rack

■ Since my workbench is in the middle of the shop, there isn't an electrical outlet nearby to plug my power tools into. And trailing an extension cord across the floor is a safety hazard. So I decided to hang a strip of outlets above the bench. With the cords running up, there is

less of a chance of tripping on them or accidentally cutting through them. And to make it even more useful, the outlet strip is attached to a plywood tool rack, so I can store tools and clamps near the workbench.

As you can see in the drawing below, there's not much to this tool

rack. You just cut a piece of 3/4" plywood to shape and screw a power strip vertically in the middle of it.

Then to hang it from the ceiling, I drilled two holes in the long end and hung it from a pair of bicycle hooks that were screwed into a cleat attached to the ceiling. This way the power strip/tool rack can be easily removed if I need the extra space for working on a tall project.

Next, I made a couple of shelves and holders for the power tools I use most often at the bench: a sander, drill, and jig saw. All that's left is to run an extension cord across the ceiling and plug in the outlet strip.

David Hodges  
Visalia, California

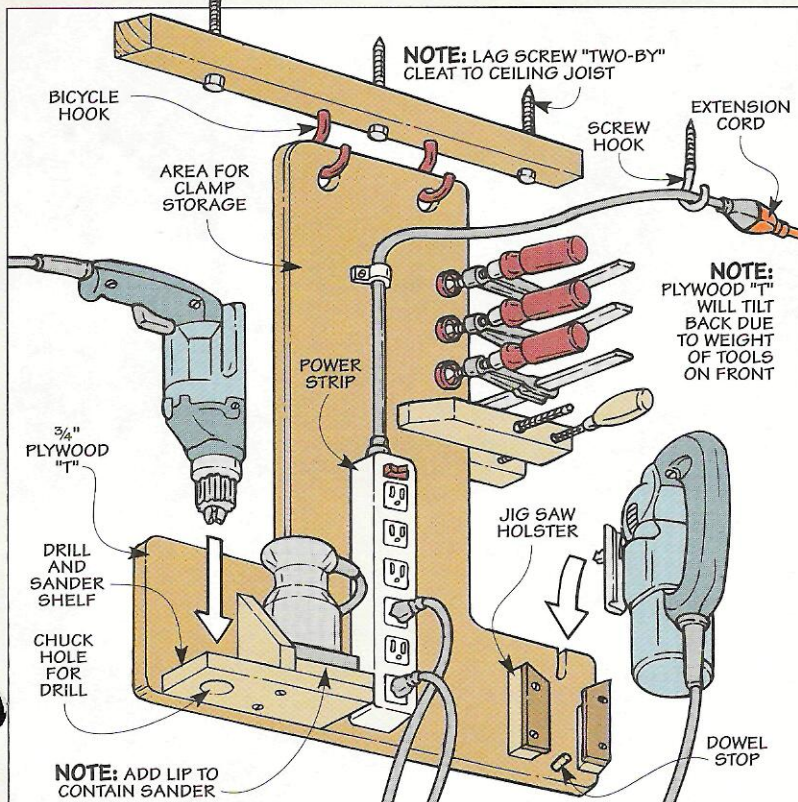

### Send in Your Shop Tips

If you have a unique shop tip, we'd like to consider featuring it in one or more of our print or electronic publications.

We'll pay up to \$200 for a tip we publish. Just write down the tip and mail it to *ShopNotes*, Attn.: Readers' Tips, 2200 Grand Ave., Des Moines, IA 50312. Or FAX it to 515-282-6741, or send us an email at [shopnotes@shopnotes.com](mailto:shopnotes@shopnotes.com). Please include your name, address, and daytime phone number in case we have any questions.

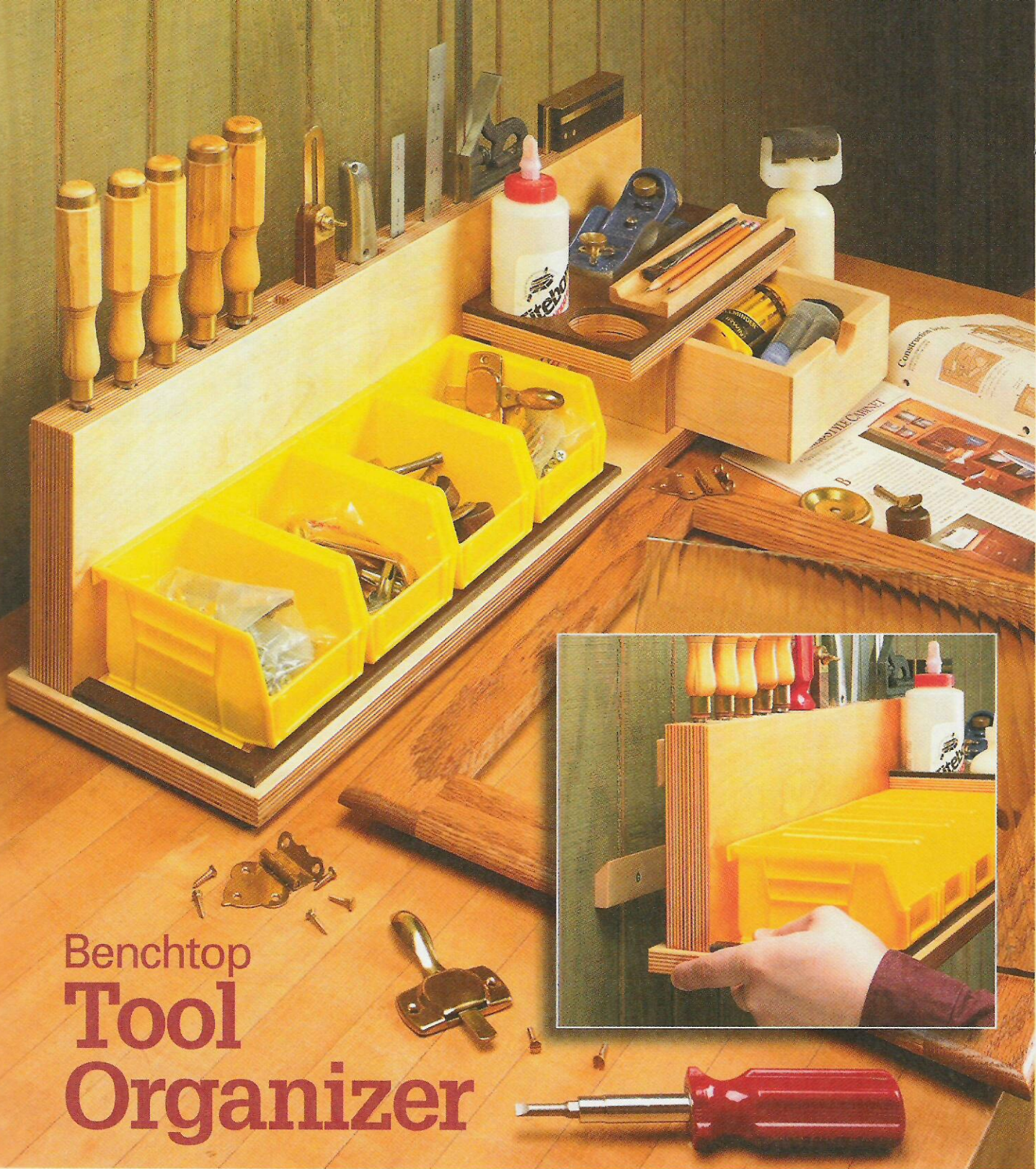

# Benchtop Tool Organizer

**I**f your workbench is anything like mine, it's a catch-all for project parts and hardware. Sometimes it's so cluttered that there's not much space to work. And the tools I use most seem to grow legs and walk off. What I need is a way to keep organized without sacrificing valuable workbench space.

That's where this tool organizer comes in. If you take a look at the photo, you can see that it's basically a large, L-shaped shelf. (You can save even more space by hanging it on the wall, as in the inset photo.) What's unique is how it uses every inch of space. The back is a tool rack for chisels, screwdrivers, and layout

tools. On one end there are some hardware bins. And at the other end there's a drawer and a smaller shelf with custom-fit recesses for a block plane, glue bottles, and a pencil tray.

This organizer isn't meant to hold all your tools — just the ones you find yourself reaching for most often. And don't worry if the tools you use

most aren't the ones shown here — it's easy to customize your organizer.

**Tool Rack** – The tool rack is made by cutting a series of dados in a piece of plywood that starts out a little more than twice as tall as the finished height of the back. (I made my rack slightly taller than my longest chisel blade.) That way, after the dados are cut, you can just rip the plywood in half and glue it together to create pockets for the tools.

**Layout** – It's best to start out by arranging your tools on an oversized piece of  $\frac{3}{4}$ " plywood, as in Figure 2. This not only lets you get a feel for how many tools to include, it also helps you figure out the room you'll need for proper spacing, as you can see in the cross section at right.

With the spacing set, you can lay out the pockets for each tool. And, to keep things straight, I marked the dados with an "X" on the edge of the plywood, as in Figure 3a.

Now the pockets can be cut in the back (A) blank on the table saw. To save time, I cut them all with a  $\frac{1}{4}$ " dado blade, making multiple passes for the wider pockets and adjusting the depth of the pocket for each tool, as you can see in Figure 3. Then after all the dados are cut, you can rip the blank in half and glue the pieces back together.

**Tool Stops** – To keep the shorter tools from dropping out of reach, I added some dowel stops. To do this, simply drill a hole in the back and fill it with a  $\frac{3}{8}$ " dowel, as shown in Figures 1 and 1a.

1 OVERVIEW

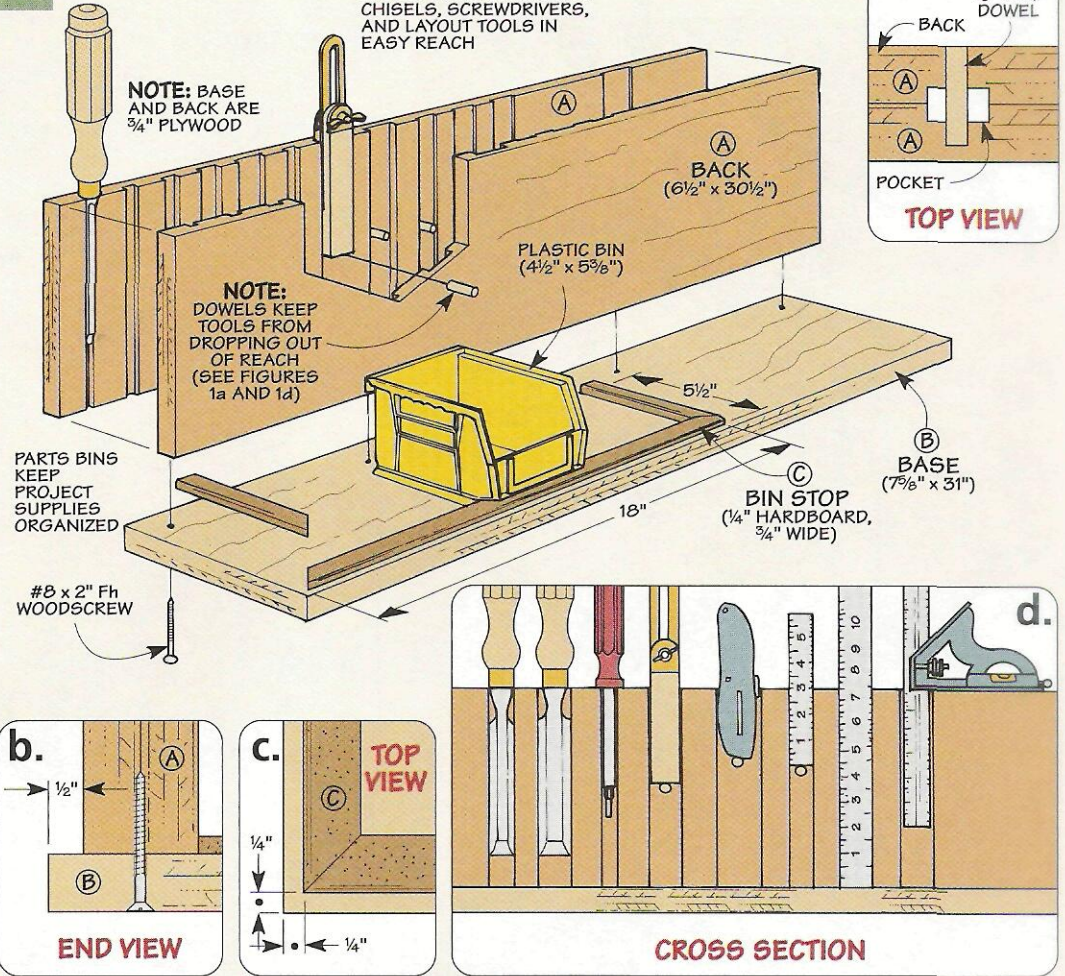

To complete the basic shelf, I cut a base (B) from  $\frac{3}{4}$ " plywood and attached it with screws, as in Figure 1b. The back is recessed  $\frac{1}{2}$ " in case you want to mount a hanging cleat.

**Bin Stops** – Along the left side of the organizer base there's a space for several plastic storage bins for

project supplies and hardware. You can find these bins at most home centers or hardware stores. To keep them from sliding off the shelf, I added  $\frac{1}{4}$ " hardboard bin stops (C). They're just mitered to fit and glued in place (Figure 1c). But first, I eased the sharp edges with sandpaper.

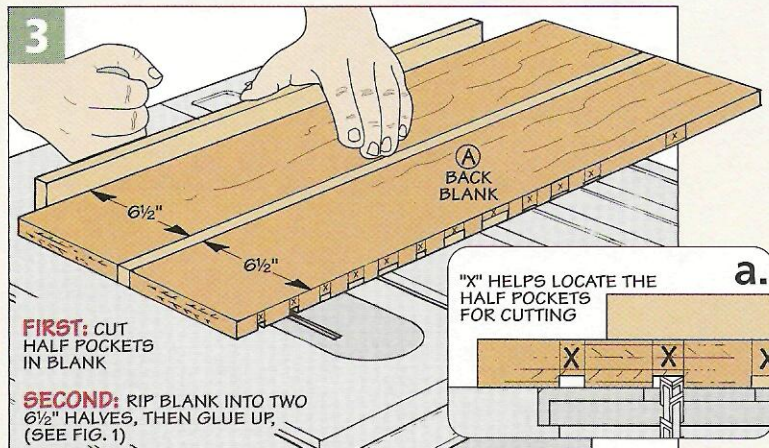
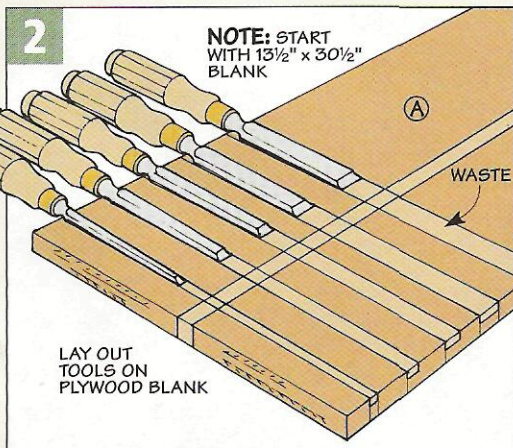

# Shelf & Drawer



▲ **Drawer and Shelf.** Increase the storage options by further customizing the organizer. A drawer and shelf hold small tools, pencils, and a glue bottle or two.

At this point, the organizer is just a shelf with a tool rack on the back. To make it even more useful, I added a couple of other features. You can adapt them in a number of ways to suit your needs. In the photo above you can see some of these features: a small shelf and drawer, a recess for a block plane, a pencil tray, and a pair of glue bottle cutouts.

**Small Shelf** – The top of the shelf is made up of two layers. This way, I could make a custom holder for my block plane. I began by cutting the shelf (D) to final size from 3/4" plywood (Figure 5). Next a top (E) is

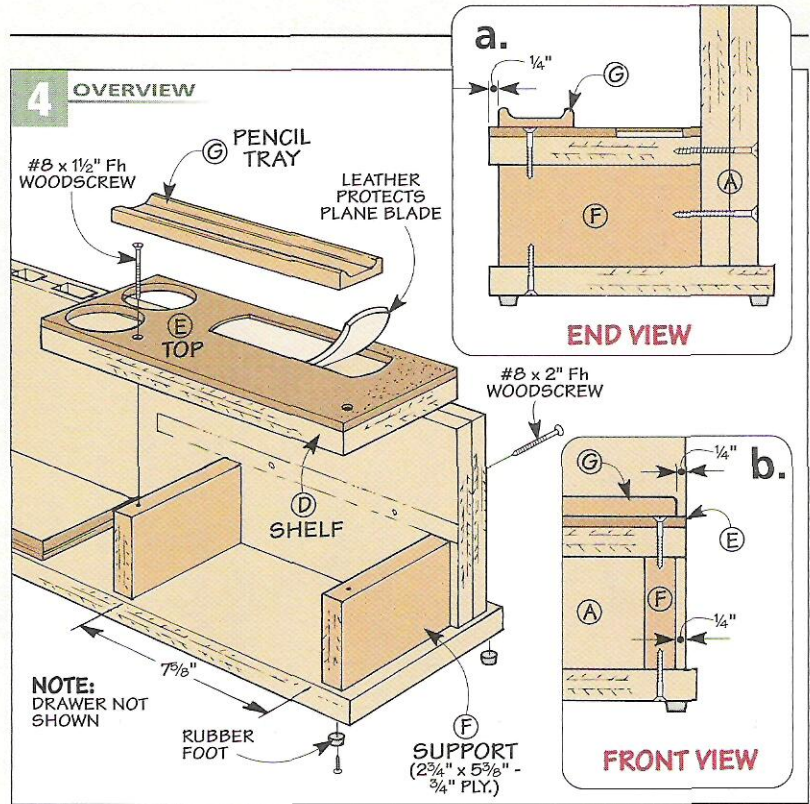

cut from 1/4" hardboard to the same size as the shelf. To create the recess for the block plane, first trace its outline on the top, as in Figure 5a. Then drill a starter hole and cut out the shape with a jig saw or scroll saw and sand the recess smooth.

Before gluing the two pieces together, I used the cutout in the top as a template to cut a piece of leather to line the recess. (Adding leather to the bottom of the recess lets me set my block plane down without dulling

the blade.) Once the top and shelf have been glued together, you can glue the leather in place.

**Glue Holder** – It seems I can never find a glue bottle when I need one. To solve this problem, I drilled a couple of holes in the shelf to provide a spot for my glue bottles. (I keep one upside down, ready to go.) All you have to do is mark the centers for the 2 7/16"-dia. holes and drill them out with a wing cutter mounted in a drill press, as in Figure 5b.

The shelf is lifted above the base by two 3/4" plywood supports (F), as shown in Figure 4. This forms an opening for a drawer (added later). Glue and screw the supports in place through the back and base. (You'll want to make sure not to screw into a tool slot.) Then the shelf can be attached to the supports with glue and screws as well (Figures 4a and 4b). For a clean look, I only used two screws to attach the shelf. This way, they'll be covered by a pencil tray that will be added next.

**Pencil Tray** – Another thing I have a hard time keeping track of are pencils. So one other feature that I

5 FIGURE

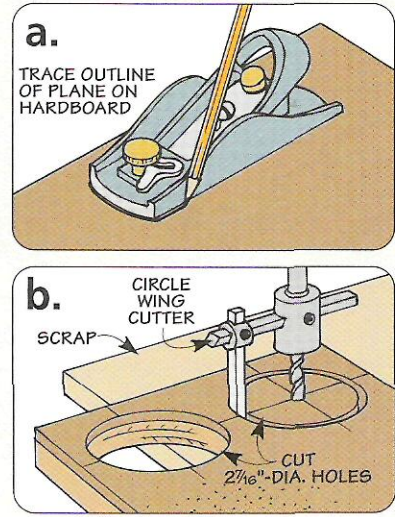
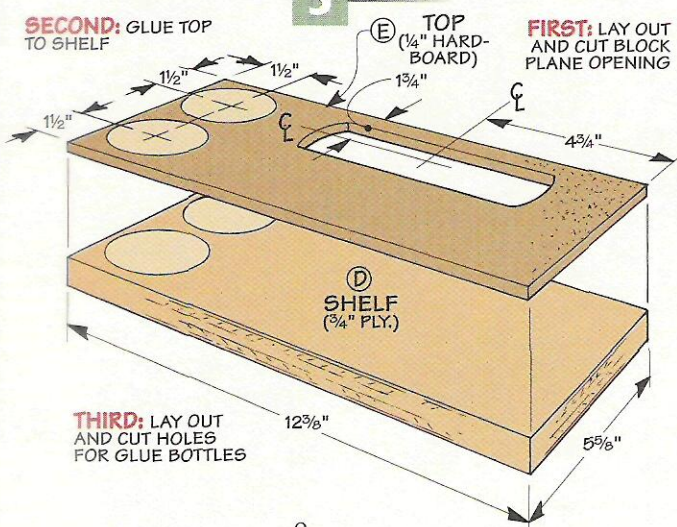



added to the shelf is a *pencil tray* (G). As you can see in Figure 6, the tray is a piece of hardwood with a wide, rounded groove that can be cut in two steps. First, rout two grooves with a core box bit, as in Figure 6a. Then, clean out the waste between the grooves with a dado blade, as in Figure 6b. After the groove is cut, smooth the bottom with some sandpaper and glue the tray to the shelf.

**Drawer** – The last piece you'll make is a simple drawer that fits under the shelf. It's a great place for keeping small items like drill bits or a tube of epoxy.

Start by ripping an extra-long blank to fit the drawer opening, allowing a  $\frac{1}{16}$ " clearance at the top. (Mine was  $2\frac{3}{4}$ " wide x 26" long.) Next I cut a groove along the length of the piece for a bottom (Figure 7b).

At this point, a *drawer front* and *back* (H) can be cut to length from the blank. Rabbits cut on each end of the front and back hold the sides, as in Figure 7a. And a half-circle is cut in the front to act as a pull.

Now, two *sides* (I) can be cut to fit between the rabbets. Finally, cut the  $\frac{1}{4}$ " hardboard *bottom* (J) to size and assemble the drawer.

To complete the organizer, I screwed on rubber feet to keep it from sliding (Figures 4 and 4b).

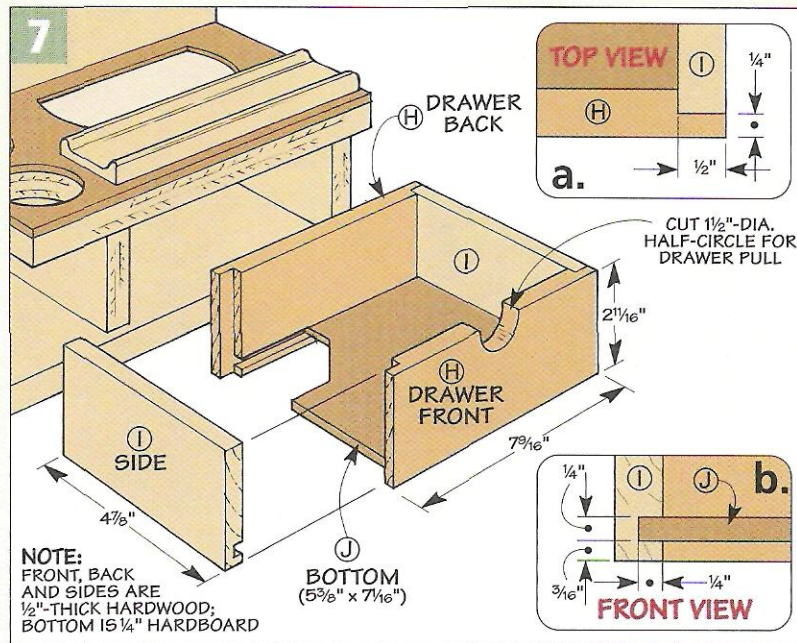
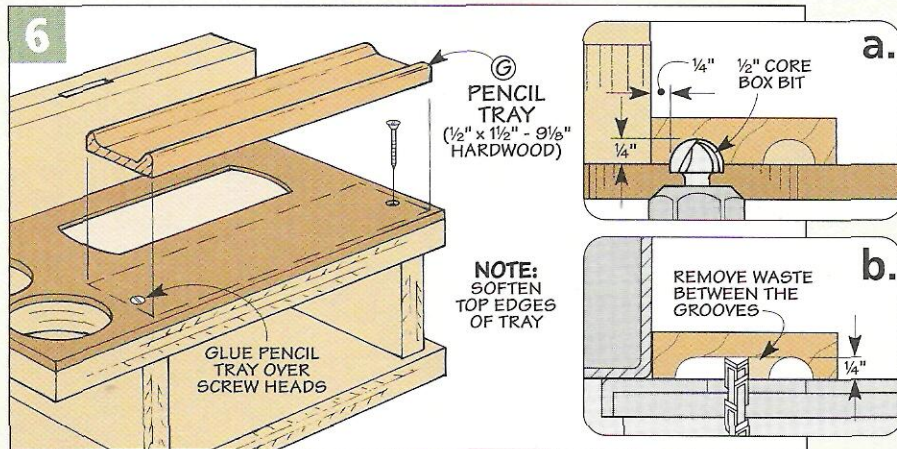

## Wall Mount

This organizer will really help keep your bench uncluttered, and you can free up even more space by hanging it on the wall. To do this, just add a simple two-part cleat system, as shown in Figure 8.

The *cleats* (K) are cut from a single piece of  $\frac{1}{2}$ "-thick hardwood. Then you can screw one half to the organizer and the other to the wall. When mounting the wall cleat, there are two things to keep in mind. First, the cleat should be level. Second, because the organizer is heavy (especially filled with tools), I made sure to screw it into two wall studs, as in Figure 8a. 🛠️

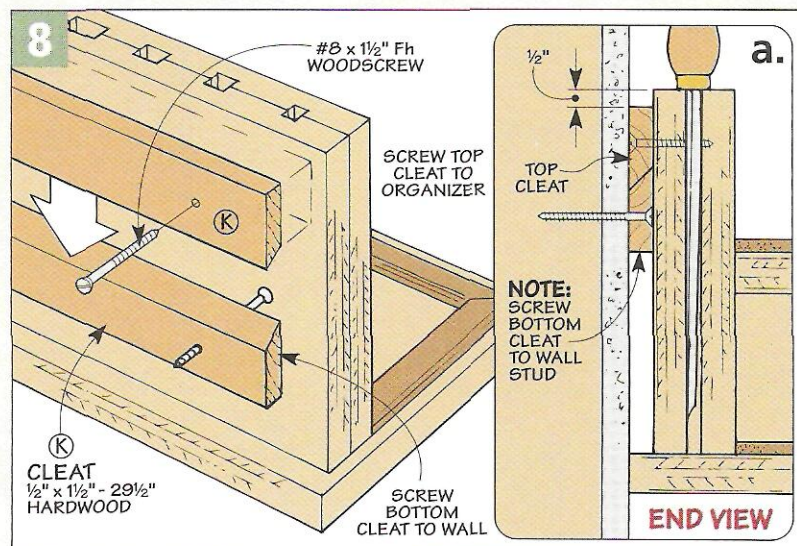

# Jig Saw Blades

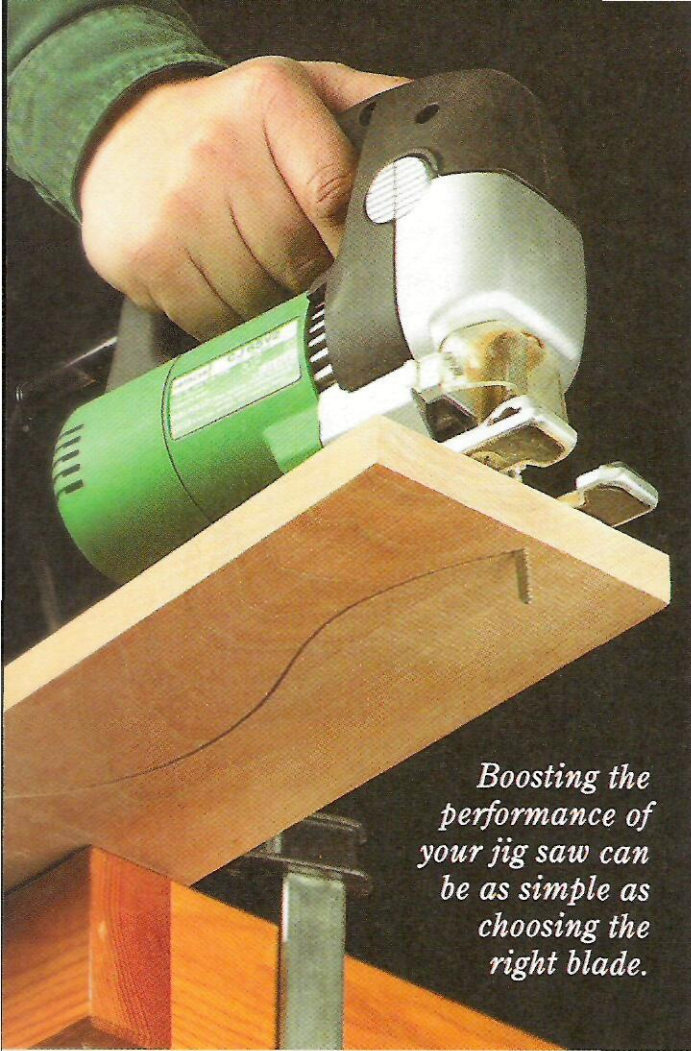

*Boosting the performance of your jig saw can be as simple as choosing the right blade.*

**W**hen I bought my first jig saw years ago, it came with two blades. This made it pretty easy to pick which one to use. I just used the first blade until it finally broke. Then I used the second one.

But times have changed. If you go to a hardware or tool store today, you're likely to find a wide assortment of jig saw blades available. In fact, there are so many blades to choose from that it can be a little overwhelming.

Fortunately, selecting the right jig saw blade isn't too difficult. To start with, you need to know what type of material you will be cutting (wood, metal, plastic, etc.). Beyond that, you need to know what kind of cuts you will be making — rough cuts, tight, scrolling cuts, or both. Then it's just a matter of knowing a few of the basics of blade design to be able to select a blade that is right for the task at hand.

**Number of Teeth** – The most important thing to consider when selecting a blade is the number of teeth per inch (tpi). Wood-cutting blades typically have anywhere from 6 to 12 tpi, and metal-cutting blades can have as many as 36 tpi.

As a general rule, the fewer the teeth, the faster the blade will cut. But this speed comes at a price. Blades with fewer teeth also tend to make rougher cuts than blades with more teeth, see the drawing at right.

One other point to consider is the thickness of the material you will be cutting. In order for the blade to work properly, you should always have at least two teeth in the workpiece at all times. So thinner materials should be cut with a blade that has finer teeth.

**Blade Clearance** – But regardless of the number of teeth, in order

for the blade to cut without binding, it has to cut a kerf that is wider than the thickness of the blade. And different types of blades use different strategies to accomplish this, see drawing at left. Most wood-cutting jig saw blades have teeth that are “set” — just like you might find on a hand saw. The tips of the teeth are bent to the left or the right in an alternating fashion. This way the blade creates a wide “path” as it cuts.

On other blades, the teeth aren't set at all. Instead, clearance is created by tapering the sides of the blade so that the back edge of the blade is thinner than the cutting edge. These “tapered” blades cost a little more than “set” blades and will cut slower. But generally they leave a smoother cut.

A third type of jig saw blade has “wavy-set” teeth (like a hack saw blade). The teeth on these blades are ground straight but are then bent in groups to create an undulating or wavy edge. These blades cut the slowest of all three, but they are the best choice for cutting metal, plastics, or many other non-wood materials.

**Bi-Metal Blades** – Most of the jig saw blades you will run across

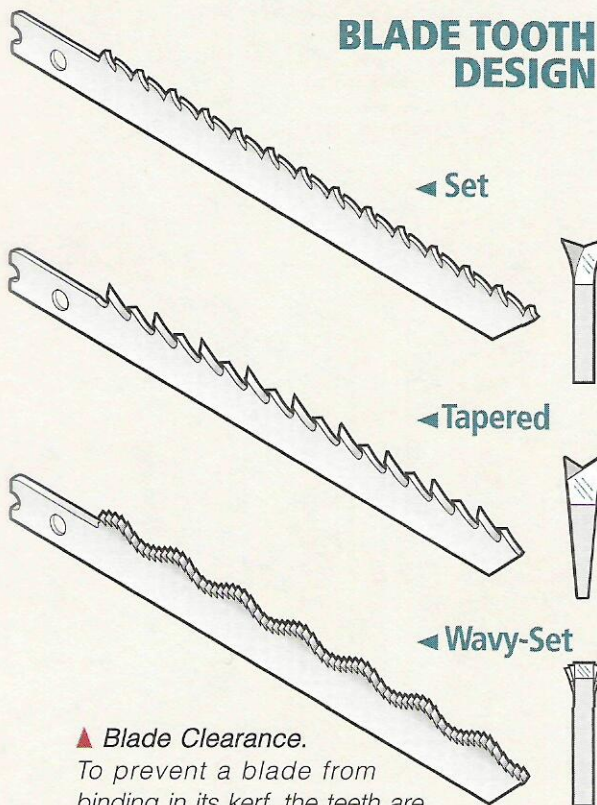

▲ **Blade Clearance.** To prevent a blade from binding in its kerf, the teeth are set or the sides of the blade are tapered.

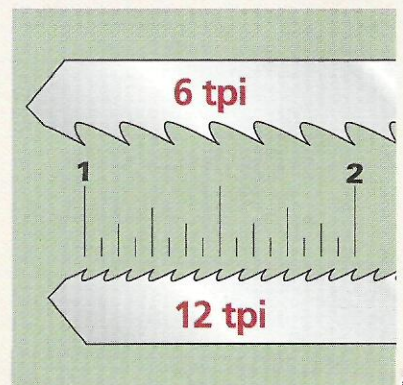

▲ **Teeth Per Inch.** Blades with more teeth per inch (tpi) will give you a smoother (but slower) cut.

are made out of carbon steel. And for cutting wood, these work just fine. But if you are going to be cutting metal, you might want to take a look at *bi-metal* blades. On a bi-metal blade, the teeth are cut into a strip of high-speed steel welded onto a blade body of softer, carbon steel (which is why they're called "bi-metal" blades). The high-speed steel teeth will hold an edge much longer than carbon steel teeth. And the softer carbon steel body of the blade will allow it to flex during use without breaking.

In addition to cutting metal, bi-metal blades are also handy for cutting wood that may have an occasional nail embedded in it. You can usually identify bi-metal blades by the fact that they are painted white.

**Blade Style** – There's one other thing to consider when selecting jig saw blades. It may seem obvious, but make sure to choose a blade that is

compatible with your saw. Some jig saws accept T-style blades, while others accept universal blades (see the photo in the margin at right). A few saws work with either one.

**Sorting It All Out** – Now that you're armed with all this information on jig saw blades, how do you put it to use? Well, I like to keep an assortment of at least two or three different types of blades so that I can select a blade that is best-suited to the task at hand.

For general woodcutting, I typically use an 8 tpi blade. This blade seems to be a good compromise between speed and quality of cut.

For construction-type tasks, like roughing out an opening for a pipe or ductwork, I switch to a blade with 6 tpi. This is the blade to use when you want to get the job done quickly and you aren't terribly concerned about the looks of the finished product. For making scroll

cuts on a furniture project, I want as smooth a cut as I can possibly get. Since finish is more important than speed, I'll use a finer blade — one with 10 or 12 tpi.

Keep in mind that there is a lot of overlap in jig saw blades. In other words, you don't have to change blades every time you make a different kind of a cut. A medium or fine-toothed blade might not cut through a 2x4 as quickly as a coarse-tooth blade, but it will still get the job done in a pinch.

I also like to keep a couple of bi-metal, wavy-set blades on hand for cutting metal or plastic. I don't use these a whole lot, but they sure come in handy when I need them.

One other thing. Since you may occasionally find yourself facing a specialized cutting job, you might want to take a look at some of the specialty jig saw blades shown in the box below. 



**T-Style**  
**Universal**  
▲ Some jig saws use T-style blades (top) while others use universal blades (bottom). A few saws will accept either style of blade.

## Specialty Blades

In addition to standard blades, there are a number of different "specialty" blades available for specific applications or for cutting materials other than wood or metal.

**Downcut Blade** – For cutting laminated or veneered surfaces, you can use a *downcut* blade. The teeth on this type of blade point down instead of up, so it cuts on the downstroke. This limits the chipping and splintering to the underside of the cut.

**Flush Cut Blade** – With a standard jig saw blade, it can be difficult to cut all the way up to an obstruction (like a wall). A *flush cut* blade has an aggressive tooth pattern and is wider, so it has a greater reach than standard blades. It comes in handy when cutting an opening in a countertop that is installed against a wall.

**Knife Edge Blade** – For cutting leather, foam rubber or vinyl, you may want to try a knife edge blade.

These blades don't have any teeth at all. Instead, the cutting edge is shaped like a knife blade. So the blade slices rather than saws its way through the workpiece.

**Carbide Grit Blade** – A jig saw probably isn't the first tool you'd

think of for cutting ceramic tile. But for short cuts, it works just fine — if you have a *carbide grit* blade. The edge of this blade is embedded with abrasive grains of carbide. So it will cut through ceramic, cast iron, and other tough materials.

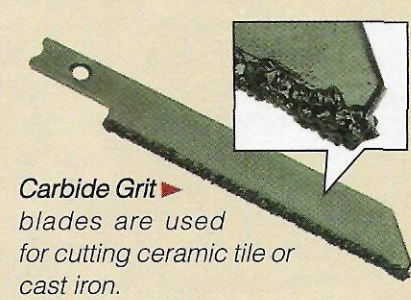
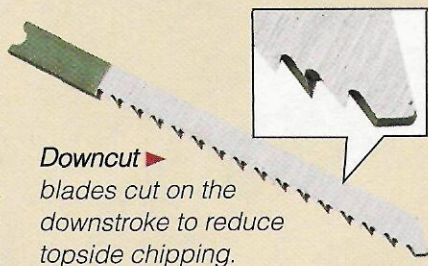

# Horizontal Mortising Machine

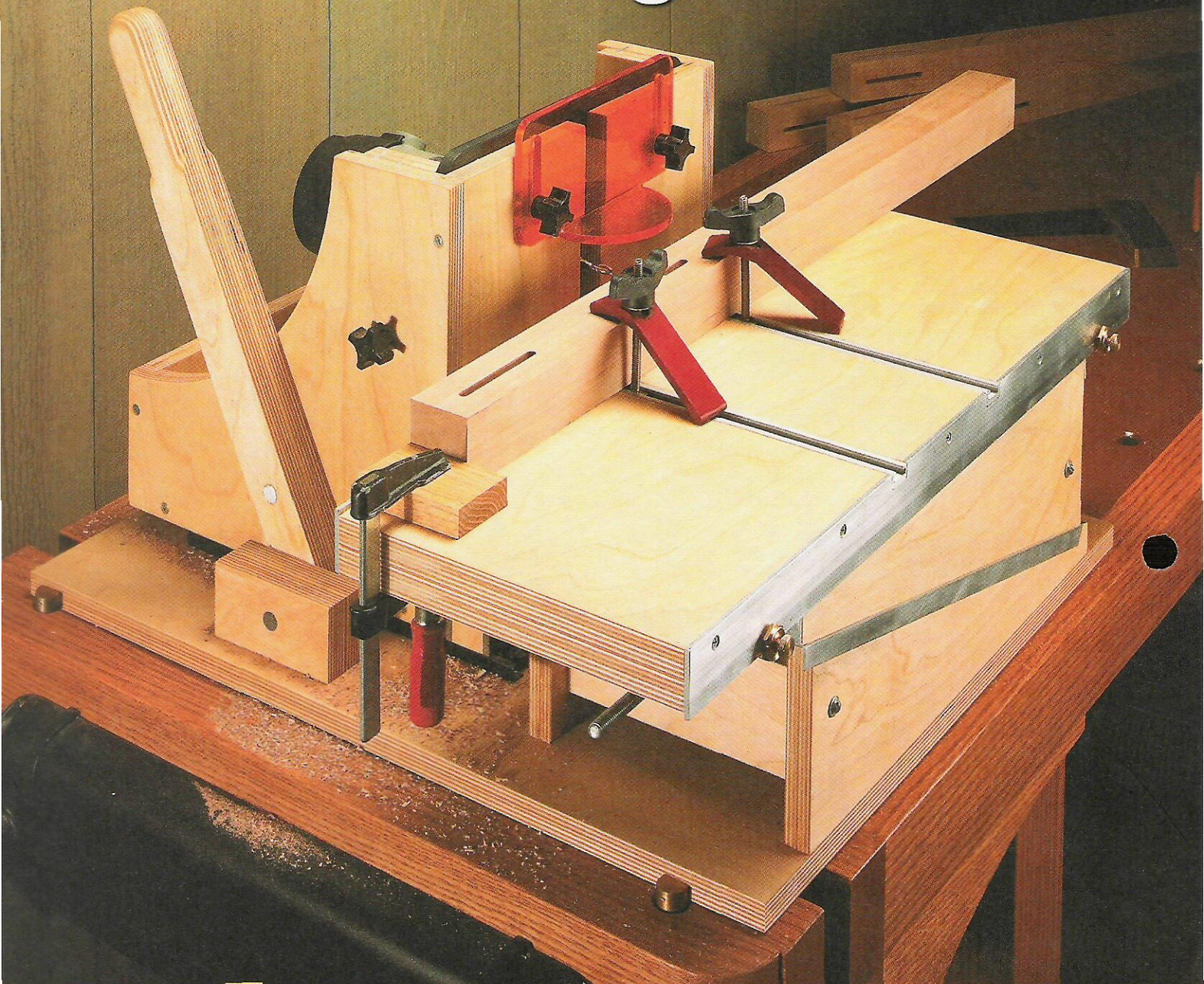

**F**or years, I've been making my mortises the "old-fashioned" way. I drill out the waste on a drill press and then square up the ends with a chisel. And there's nothing wrong with this method. But if you have a lot of mortises to make, it really becomes a "boring" task (not to mention time-consuming). Which is why I was so excited the first time I tried out this mortising machine.

What makes this mortising machine so fantastic is the fact that it can create perfect mortises quickly and easily. The way it works is simple. The workpiece is clamped to a sliding table, and the router is mounted to a carriage

that travels on a pair of drawer slides. By pulling the lever arm forward, the router bit is plunged into the workpiece. Then you just slide the table back and forth to rout the mortise. The whole thing takes about 30 seconds.

To make it even easier to use, this mortising machine has several adjustment features. To fine-tune the position of the mortise on the thickness of your workpiece, the sliding table can be raised or lowered by turning a knob. And a couple of adjustable stops on the front of the sliding table allow you to set the length of the mortise. For more on setting up the machine, see page 21.

# FEATURE PROJECT

**EXPLODED VIEW**  
**OVERALL DIMENSIONS:**  
 23 3/4" W x 24 3/8" D x 18" H

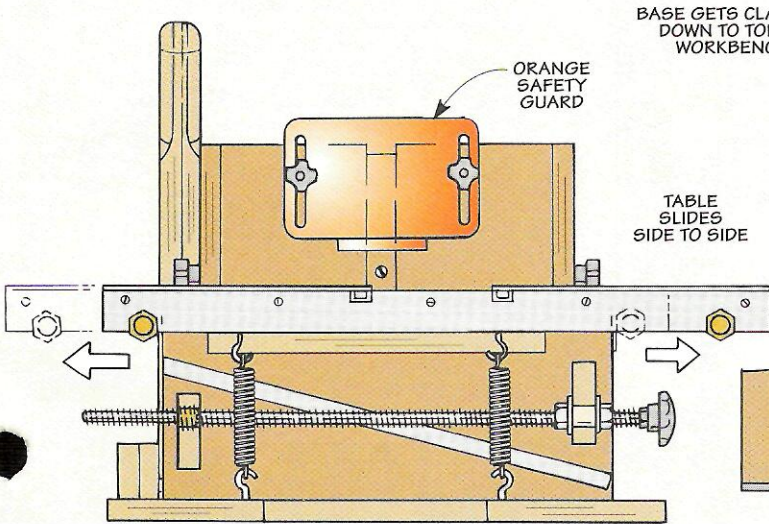
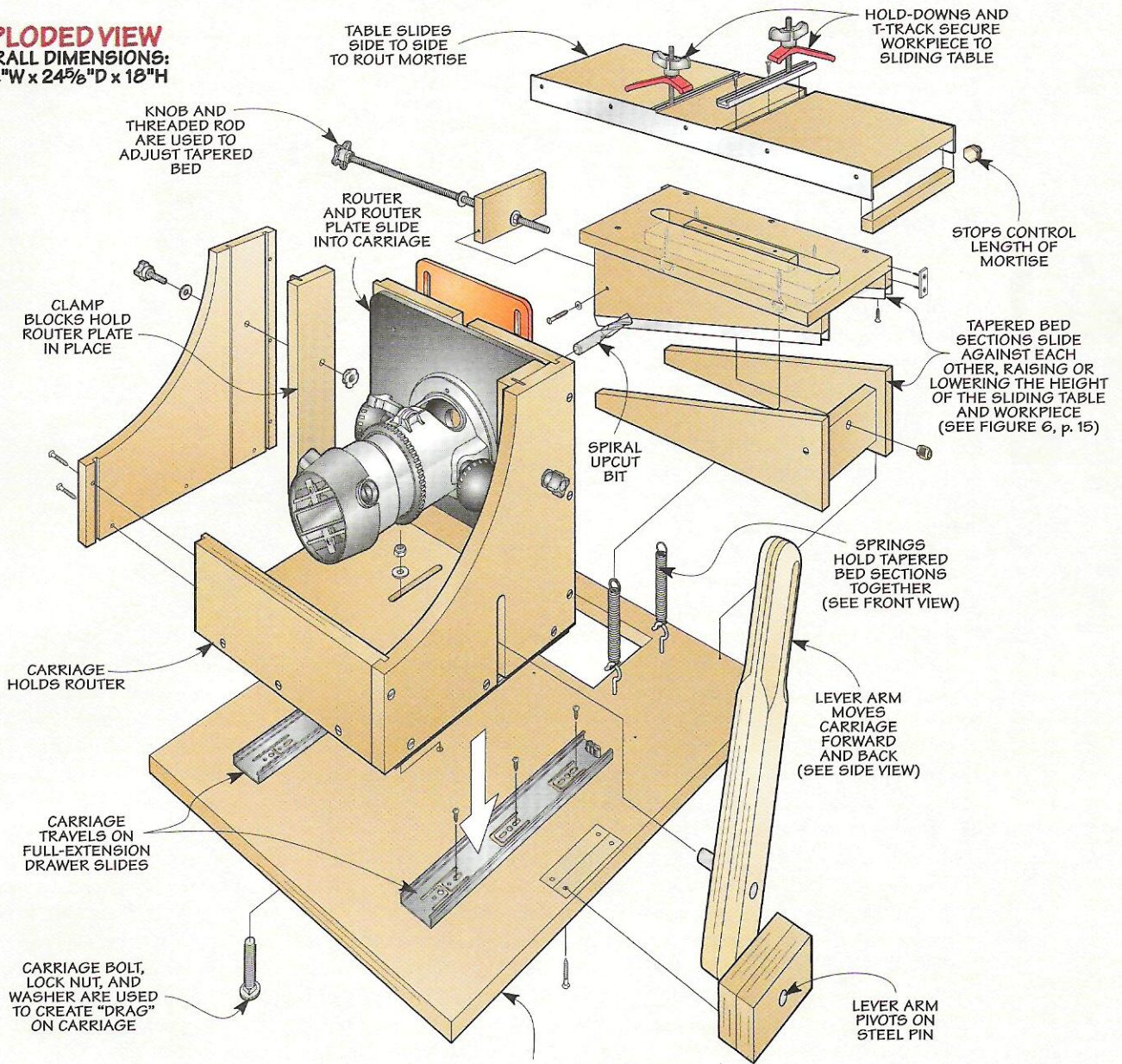

**FRONT VIEW**  
 (PARTIAL CROSS SECTION)

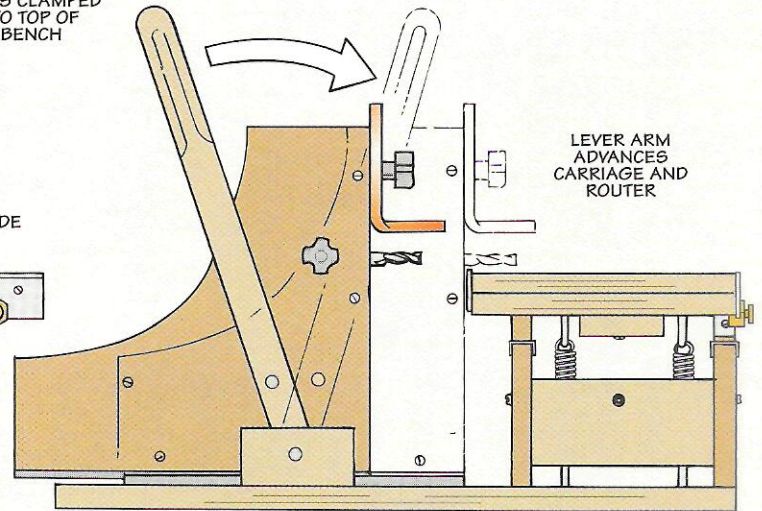

**SIDE VIEW**

# Tapered Bed

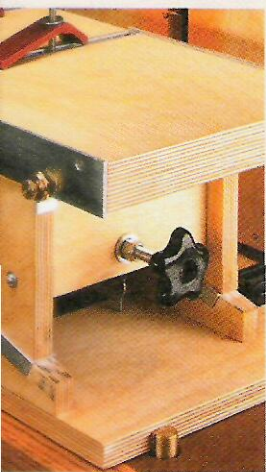

The mortising machine can be broken down into three main components: a tapered bed, a sliding table, and a carriage. These three components work together in such a way that they allow you to easily adjust the length and depth of the mortise, as well as its location on the thickness of the workpiece.

The bed is the foundation of the mortising machine, so I built it first. It's made up of two tapered sections, just like the bed on a jointer. Turning a knob at the end of the bed causes the upper section to slide against the lower section, raising or lowering the overall height of the bed and the workpiece (see photo at left).

**Base** - Before making the tapered sections of the bed, I cut out a piece of 3/4" plywood for the *base* (A), as you see in Figure 1. Then you can cut an opening near the front of the base and lay out and drill the screw holes that are shown in Figure 1. (The opening in the base is to allow you to assemble and make adjustments to the sliding table that will be added later.)

The tapered bed sections are made by cutting four identical tapered *sides* (B) from 3/4" plywood. In Figure 2 you can see how I used a simple jig on the table saw to cut the tapers. (The jig is also shown at left in the margin drawing.) After the

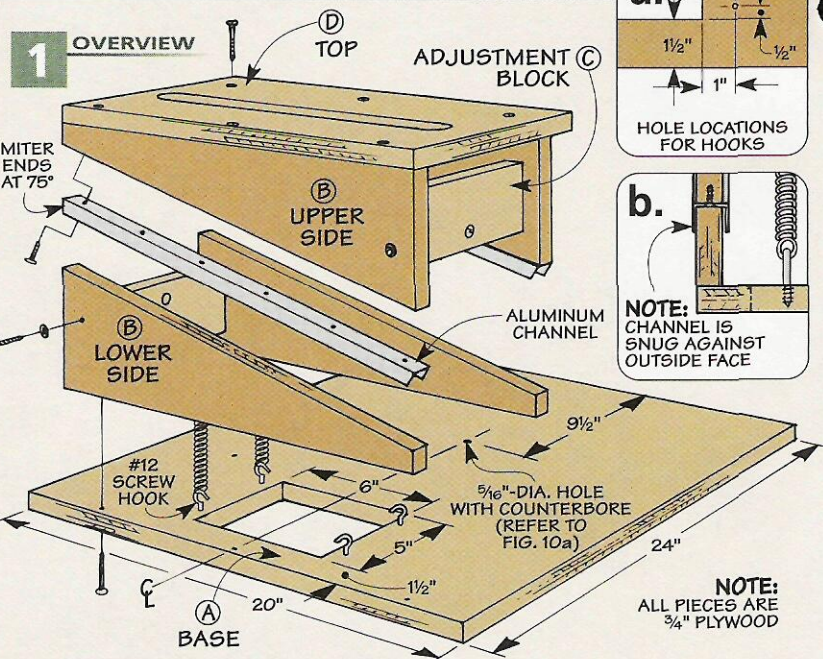

**▲ Height Adjustment.** Turning a knob at the end of the tapered bed will raise or lower the sliding table.

pieces are cut, you'll also need to drill a hole in each one for an adjustment block that is added later.

To allow the tapered sections of the bed to slide smoothly against each other, I used some aluminum channel. The channel is attached to the bottom edge of the upper tapered section so that it fits over the edges of the lower section, just as you see in Figure 1b.

The aluminum channel also helps to keep the upper and lower halves of the bed flush and aligned. But in order for this to work, the channel needs to be accurately positioned on

the edges of the upper sides. To do this, I used the top of my table saw as working surface, as you see in Figure 3. Carpet tape is used to hold the channel in place while you drill pilot holes and screw it down.

**Adjustment Blocks** - Each pair of sides is connected with an *adjustment block* (C). These are just a couple of rectangular pieces of plywood. Each block will be held in place by just two screws, one on each side. This allows the adjustment blocks to pivot as the two tapered bed sections slide against each other (Figure 6).

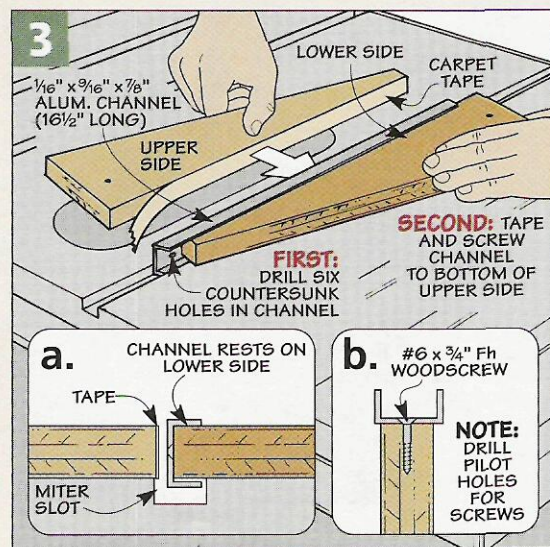
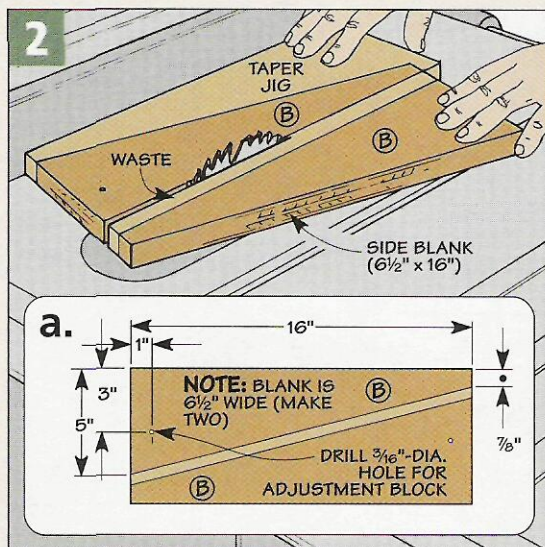
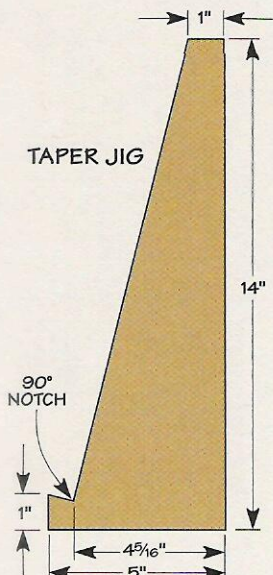

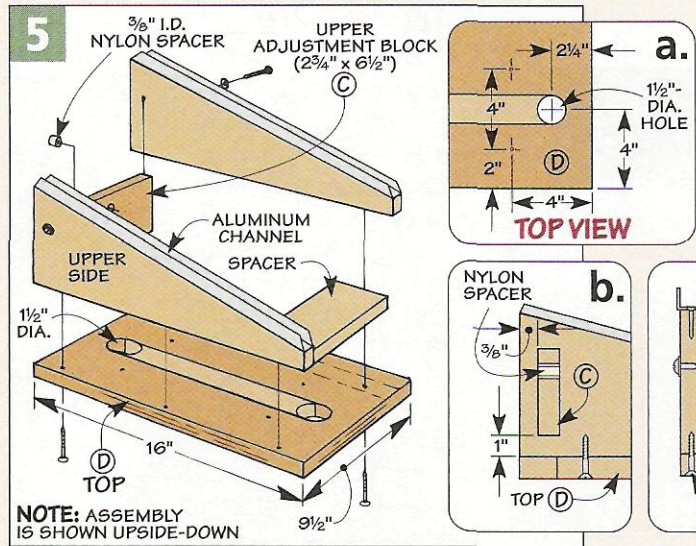
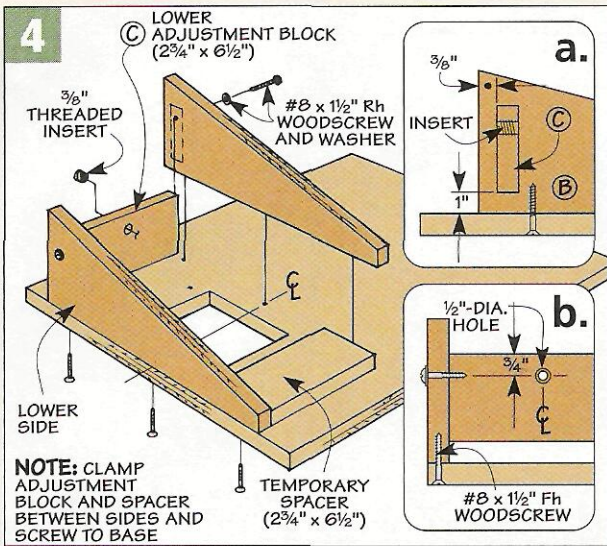

The adjustment block on the lower section of the bed has a threaded insert installed in the center, as you can see in Figure 4a. Once this is done, you can add the two lower sides and the adjustment block to the base of the mortising machine. To do this, I clamped the sides and adjustment block together as a unit. (I also clamped a spacer

block in between the two sides.) Then I screwed the tapered sides to the base. Finally, you can screw the adjustment block in place between the two sides (Figure 4).

The upper half of the tapered bed is a little different. Instead of a threaded insert, a nylon spacer is installed in the adjustment block (Figures 5b and 5c). And in addition

to the adjustment block, you also need to make a bed top (D). This piece has a long slot that will receive the sliding table later. After cutting the slot, you can screw the top to the upper sides of the tapered bed and add the upper adjustment block.

**Assembly** – With both halves of the tapered bed complete, you can assemble the two sections. The upper section is held down to the lower sections with four strong springs. The springs hold the sections together while still allowing them to slide.

To assemble the two sections, I started by installing screw hooks for the springs in the base and in the underside of the bed top (Figures 1 and 6). The springs have a loop on each end that will be slipped over the screw hooks later, see margin photo.

After the screw hooks are installed, you can add the threaded rod, washers, lock nuts, and knob. This hardware is installed on the adjustment block on the upper section of the bed, as you see in Figure 6a. Once it is in place, you can thread the rod into the threaded insert in the lower adjustment block and then set the upper bed section on the lower bed section. Finally, using a pair of needle-nose pliers, hook the ends of the springs over the screw hooks, see drawing in margin.



▲ **Spring.** The two halves of the tapered bed are held together with springs.

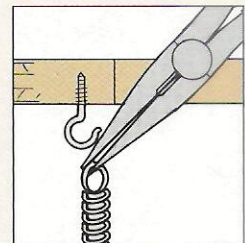
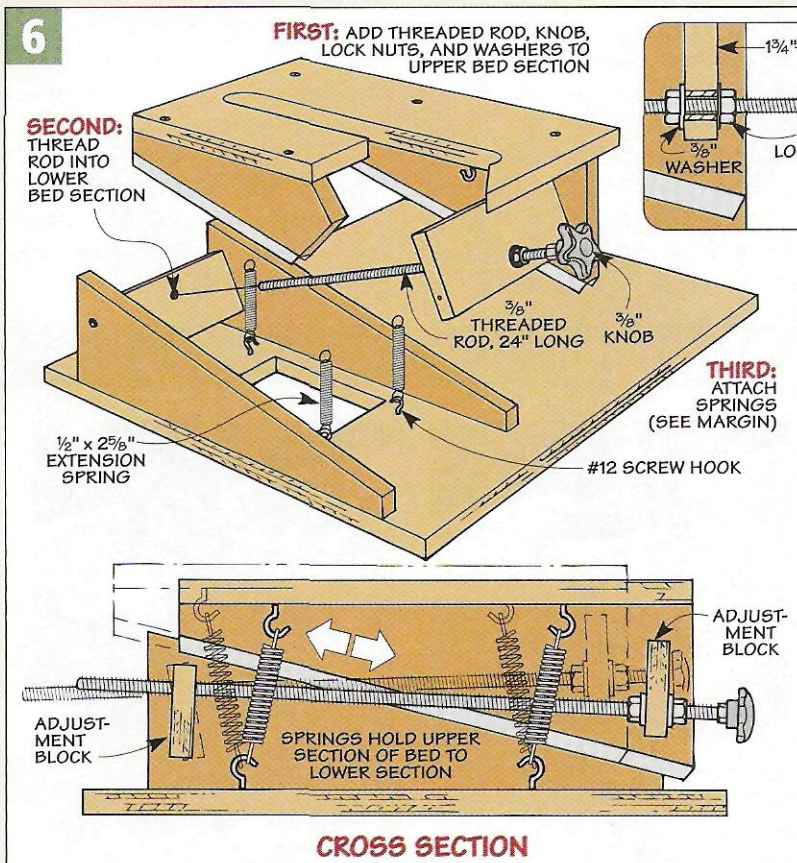

▲ **Attaching Spring.** With the jig turned upside-down, and working through the opening in the base, use a pair of needle-nose pliers to grasp the end of the spring and slip it over the screw hook.

# Sliding Table

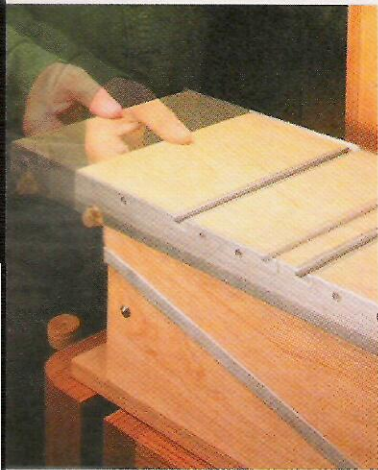

With the tapered bed complete, the most difficult part of building the mortising machine is behind you. The next step is to make the sliding table that rides on top of the bed.

The table is just a piece of plywood with a couple strips of aluminum bar stock screwed to the edges. This aluminum hangs down and creates a lip on both edges of the table. This

▲ *Sliding Table.* To rout a mortise, the table slides from side to side on the tapered bed.

allows the table to straddle the top of the tapered bed and slide from side to side (Figure 6).

To make the sliding table, I started by cutting a piece of plywood for the table (E). This piece needs to be carefully sized to match the width of the tapered bed top. Once this is done, you can cut a couple of dados across the table for some aluminum T-track that is added later (Figure 7).

The next step is to add the aluminum bar stock to the edges of the table (Figure 7). Both pieces of aluminum are the same size, but they require a little different treatment. The piece on the front edge is attached so that it is flush with the top of the table. After screwing it in place, mark out the location of the dados on the inside face of the

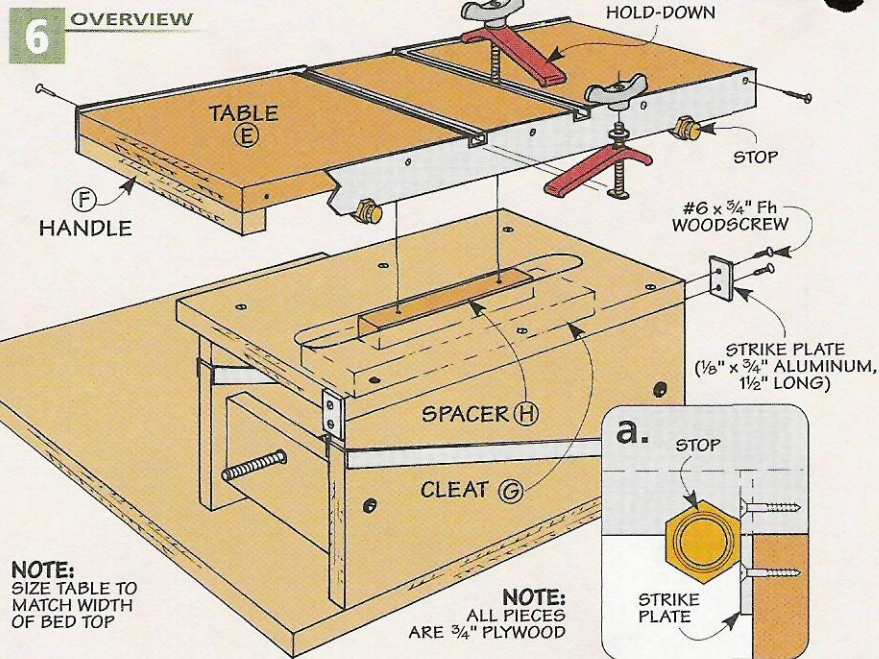

aluminum. The remove the aluminum and cut and file the notches following the steps in the box below.

On the back edge of the table, the aluminum stands proud of the top of the table by 1/8" to create a lip. (This lip will act as a fence for the workpiece that is being mortised.) After the aluminum is screwed in place, a shallow notch can be filed down at the center, so it's flush with the table.

Once you have the aluminum screwed to both edges of the table, you can place the table over the tapered bed and check the fit. The

table should slide smoothly side to side without any play. If the fit is too loose, you may have to remove the back aluminum piece and trim the table slightly. If the fit is too tight, try sanding the back edge of the top of the tapered bed. Shop Note: You can improve the sliding action of the table by waxing the top of the tapered bed.

**T-Track** – Once the aluminum is attached to the sides of the table, the T-track can be added. The T-track will be used along with a couple of hold-downs to clamp the workpiece

## Cutting Notches in Aluminum

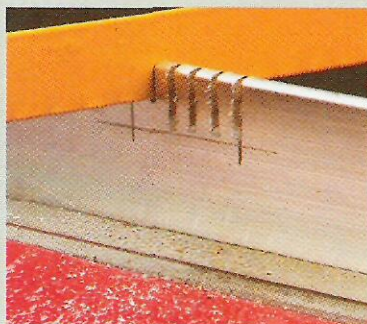

▲ *Cut.* To create the notches for the T-track, start by cutting a row of kerfs with a hack saw.

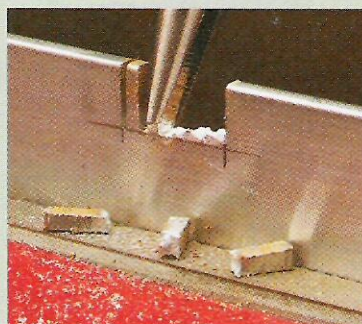

▲ *Snap.* Using a pair of needle-nose pliers, snap off the remaining waste pieces one by one.



▲ *File.* Finally, smooth out the bottom and sides of the notch with a narrow, triangular file.



in place. It is simply cut to length and screwed in place. (Note that the T-track is cut flush with the aluminum on the front edge of the table.)

**Handles** – To make it easier to get a grip on the table when sliding it, I added a handle at each end, on the bottom face. Each *handle (F)* is just a narrow piece of plywood that is glued and screwed flush with the end. You can see these in Figure 8.

**Cleat** – Now that you have the sliding table complete, you can add it to the tapered bed. The trick here is to secure the table to the bed, but still allow it to slide smoothly from side to side. If you take a look at Figure 8, you can see how this is done. A cleat and spacer block are used to “pinch” the table to the top of the tapered bed. The cleat will get screwed down just tight enough to allow the table to slide smoothly.

The *cleat (G)* and *spacer (H)* are cut from 3/4" plywood. After cutting them to size, I turned the sliding table over and positioned the two pieces using carpet tape (Figure 8). The carpet tape holds the pieces in place while you drill the pilot and shank holes for the screws, as shown in Figure 8a. Once the holes are drilled, you can remove the spacer block and cleat from the sliding table in order to add the table to the tapered bed.

**Strike Plates** – Before you actually attach the sliding table to the

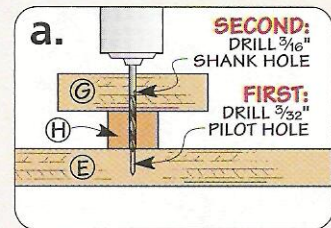
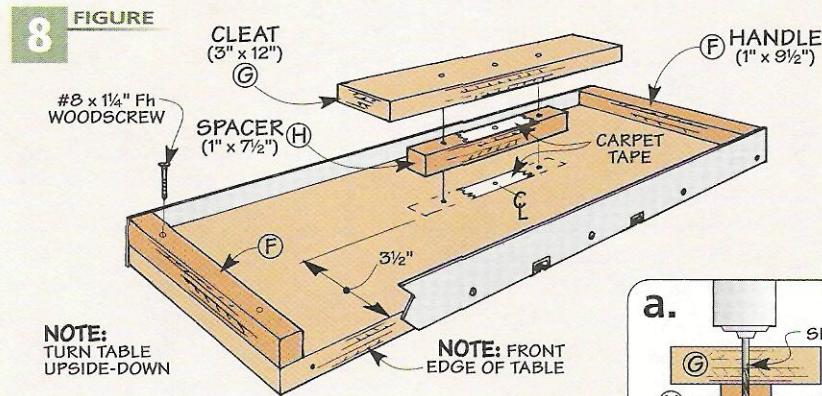
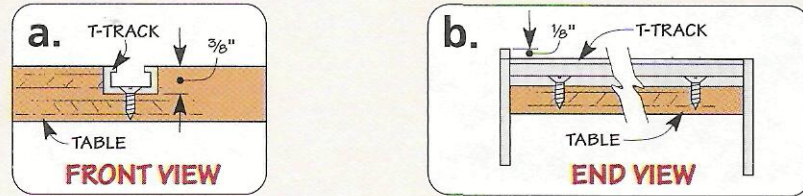
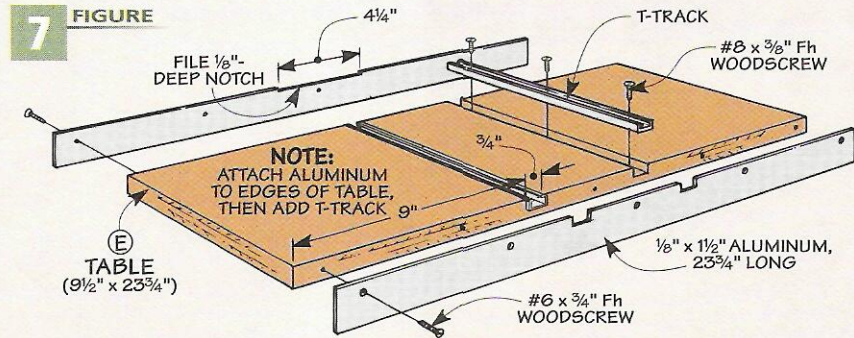

tapered bed, there is one small detail to take care of. I added a small piece of aluminum bar stock to each end of the tapered bed, as you can see in Figure 6. These pieces of aluminum will serve as strike plates for the stops that are added later. But it's

much easier to screw them in place at this point (before the sliding table has been added).

**Assembly** – Once the strike plates are in place, you can add the sliding table to the tapered bed and screw the spacer and cleat in place, just as you see in Figure 9. Tighten the screws just enough so that the table slides smoothly.

**Stops** – One of the last things to add to the sliding table is a couple of stops. These can be adjusted to limit the travel of the table in order to control the length of the mortise you want to make. The stops couldn't be much simpler. I just used a pair of brass stair gauges, see photo in margin. (You can find stair gauges at most hardware stores.) The stops simply clamp onto the aluminum strip on the front of the sliding table.



▲ **Stops.** To control the length of the mortise, a pair of brass stair gauges are used as stops.

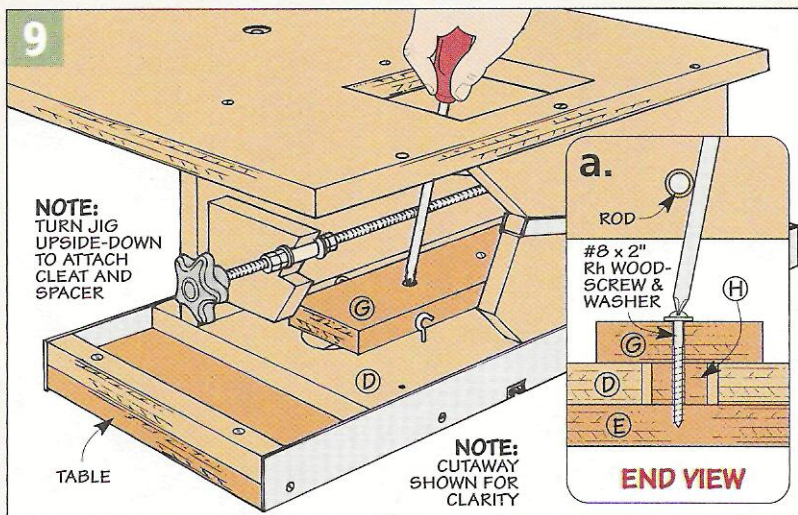

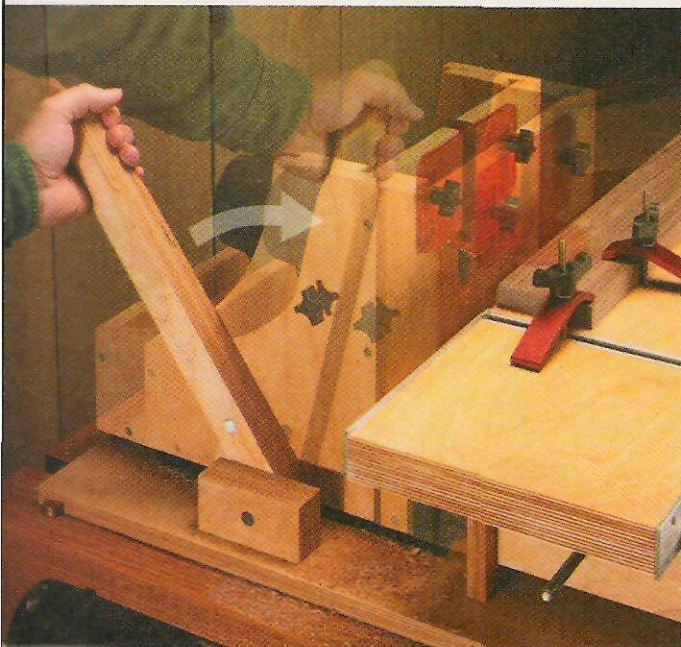

▲ **Lever Arm.** The carriage travels on a pair of drawer slides. A lever arm is used to move the carriage forward or backward.

The sliding table and tapered bed work together to hold the workpiece that is being mortised. But to hold the router, you need to build a carriage. This carriage is really nothing more than an open box that travels back and forth on drawer slides. The carriage doesn't exactly hold the router. Instead, the router is mounted to a *router plate* which fits into the carriage. (See page 35 for more information on the router plate I used.)

To build the carriage, I started by cutting a *front* (I), *back* (J), and two *sides* (K) to size from 3/4" plywood. The side pieces start off as 12" square blanks. But when it comes to cutting the front and back, you'll need to size these pieces 1/2" wider

## Carriage

### 10 OVERVIEW

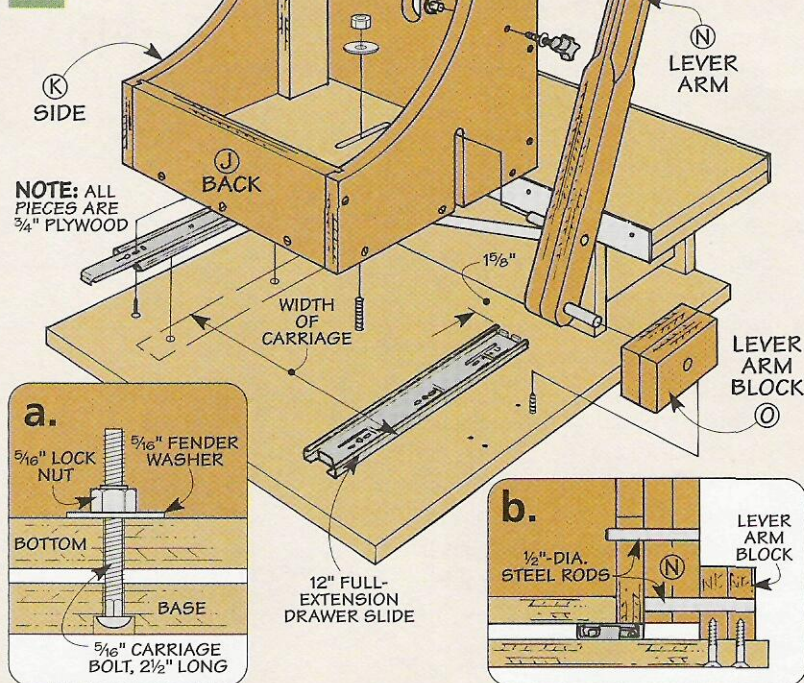

NOTE: ALL PIECES ARE 3/4" PLYWOOD

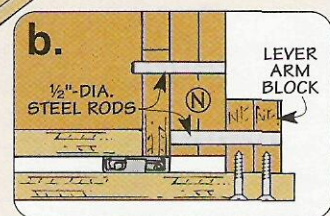
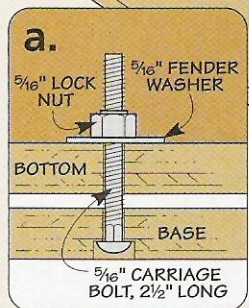

than the width of your router plate. (The plate I used is 11 3/4" wide.)

The front and back are joined to the sides with tongue and groove joints. So the next step is to cut grooves near the edges of the sides and tongues on the ends of the front and back pieces to fit (Figures 11, 11a, and 11b).

Next, you'll need to cut a clearance slot in the front piece to allow

you to slide the router in and out of the mortising machine without having to remove the router bit.

The left side of the carriage also has a slot cut in it. This slot is for a steel rod that is part of the lever arm assembly that will be added later.

Finally, you'll need to drill a 5/16"-dia. hole and cut a 1/8"-wide kerf along the inside face of each side piece. These are for some clamp

### 11 FIGURE

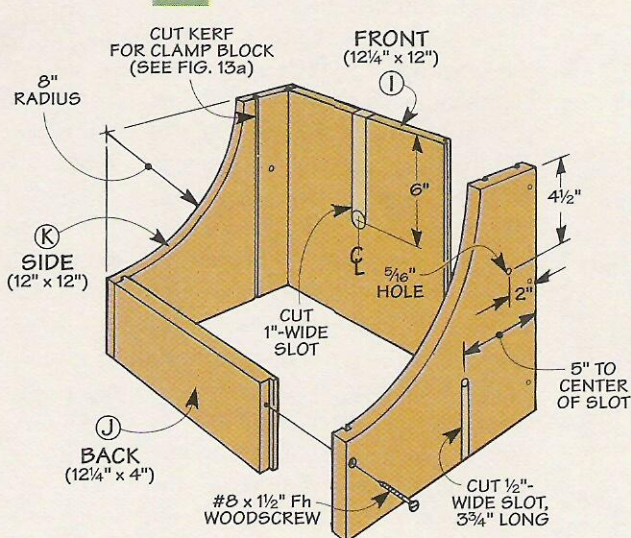

### 11a TOP VIEW

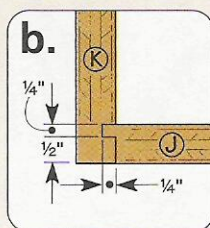
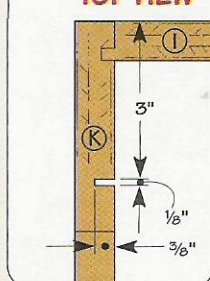

### 12 FIGURE

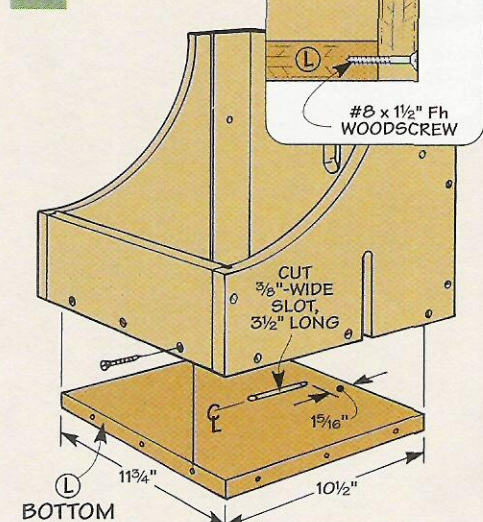

blocks that will be used to hold the router and router plate in place.

Before assembling the pieces, you can lay out and cut an arc on each side piece. Once this is done, all you have to do is glue and screw the sides to the front and back.

**Bottom** – The *bottom* (L) of the carriage is also cut from 3/4" plywood. It is simply sized to fit the opening in the bottom of the carriage. Before it gets screwed in place, a slot is cut in the center for a carriage bolt that will be used to help secure the carriage to the base of the mortising machine, as shown in Figures 10 and 12.

**Clamp Blocks** – At this point, the basic structure of the carriage is complete. But you still need a way to secure the router plate to the carriage. I did this by making a couple of clamp blocks, as you see in Figures 13 and 13a.

The *clamp blocks* (M) are nothing more than a couple of pieces of plywood that fit against the back of the router plate and the sides of the carriage. I cut the blocks slightly wide to begin with. (I made mine 2 3/4".) Later, they will get trimmed to final width.

As you can see in Figure 13, I used aluminum splines to align the clamp blocks with the sides of the carriage. A kerf is cut in each block and then an aluminum spline is epoxied in

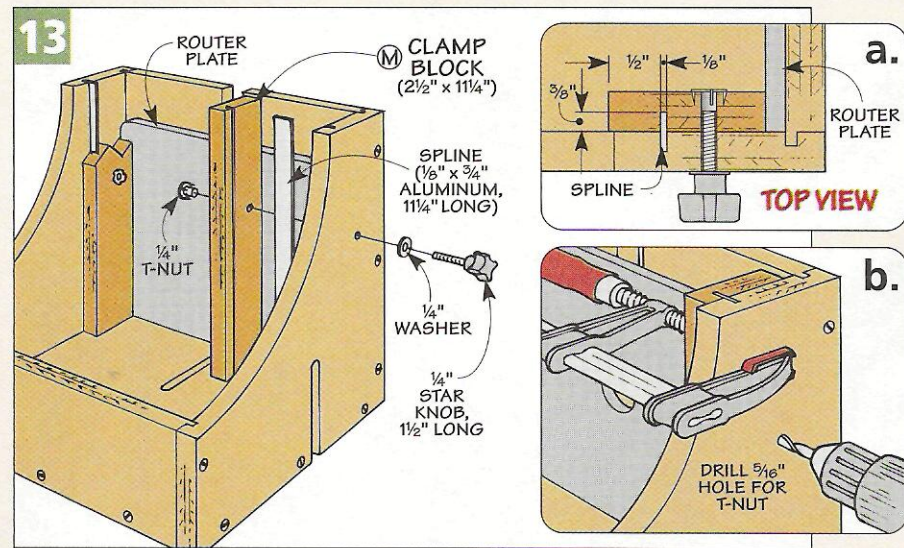

place. After this is done, you can trim the width of the blocks so the router plate just fits between the blocks and the front plate of the carriage, as shown in Figure 13a.

The last step is to clamp the blocks in place and drill a hole in each one for a T-nut and threaded knob (Figure 13b).

**Drawer Slides** – The carriage is mounted to the base of the mortising machine with a pair of full-extension drawer slides. This allows the carriage to slide smoothly back and forth. The drawer slides are mounted so that they are flush with the front edge of the carriage when the carriage is pushed all the way forward and butted against the edge

of the sliding table. You can see what I'm talking about in Figure 14a.

The drawer slides travel so effortlessly that it can be a little hard to control the movement of the carriage. To create a bit of drag on the carriage, I added a carriage bolt, fender washer, and lock nut to the carriage and base of the machine, as shown in Figure 10a. You can vary the amount of friction by tightening or loosening the lock nut.

**Lever Arm** – The only thing left to add in order to complete the carriage is the lever arm assembly. As you can see in the photo on the opposite page, this arm simply provides a convenient way to move the carriage forward and backward.

This assembly is made up of two parts — a *lever arm* (N) and a *lever arm block* (O). Both of these pieces are cut from blanks that are glued up from two layers of 3/4" plywood. After the arm is cut to shape, the edges are rounded over on one end to create a comfortable grip for your hand.

The lever arm pivots on a short length of steel rod that is epoxied into a hole in the lever arm block. A second rod epoxied into the arm engages the slot on the side of the carriage and moves it forward or backward when the arm is pulled. After the holes are drilled and the rods are epoxied into place, you can simply screw the lever arm block to the base of the machine.

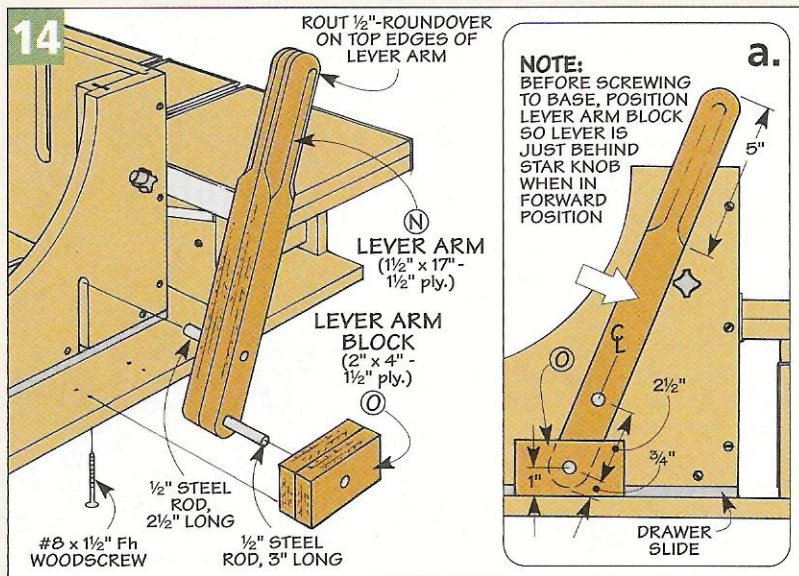

# Guard & Dust Hood

At this point, the mortising machine is just about complete. There's just a couple of features to add.

**Guard** - There's something a little unnerving about the thought of an exposed, spinning router bit poking out from the opening in the front of the carriage. So I thought it would be a good idea to add a router bit guard, as you see in Figure 15.

I purchased a router bit guard made out of orange polycarbonate (*Lexan*). Adding the bit guard is simply a matter of installing a pair of threaded inserts in the front of the carriage. The guard is then held in place with a couple of star knobs and washers (Figure 15a).

**Optional Dust Hood** - There's no denying the fact that this mortising machine creates a lot of chips and dust. While I was using it, I found myself having to stop every so often to vacuum up the sawdust. That's when I decided that a dust hood would be a great option.

The dust hood attaches to the front of the carriage. When it's connected to a shop vacuum or dust collector, it traps a good deal of the sawdust created by the router.

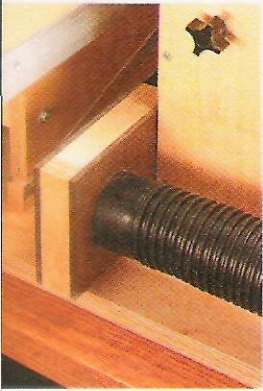
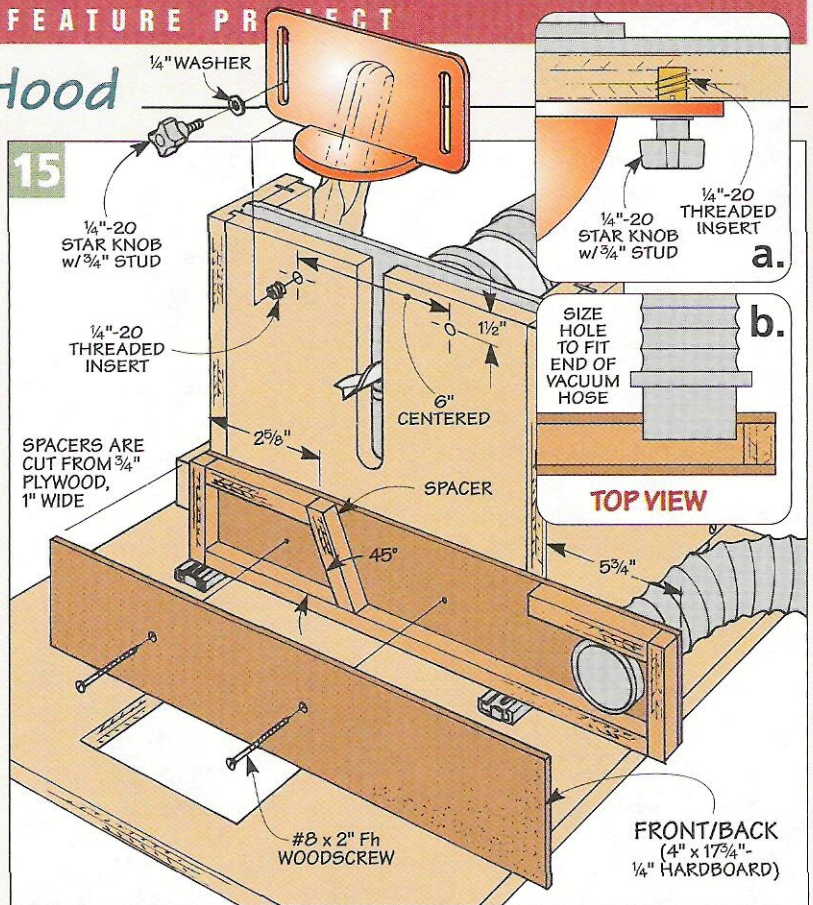

### ▲ Dust Hood.

When hooked up to a shop vacuum, this optional dust hood reduces the shower of wood chips to a trickle.

## Materials

### Tapered Bed

A Base (1)	20 x 24 - 3/4 Plywood
B Sides (4)	5 x 16 - 3/4 Plywood
C Adjustment Blocks (2)	2 3/4 x 6 1/2 - 3/4 Plywood
D Top (1)	9 1/2 x 16 - 3/4 Plywood

### Sliding Table

E Table (1)	9 1/2 x 23 3/4 - 3/4 Plywood
F Handles (2)	1 x 9 1/2 - 3/4 Plywood
G Cleat (1)	3 x 12 - 3/4 Plywood
H Spacer (1)	1 x 7 1/2 - 3/4 Plywood

### Carriage

I Front (1)	12 1/4 x 12 - 3/4 Plywood
J Back (1)	12 1/4 x 4 - 3/4 Plywood
K Sides (2)	12 x 12 - 3/4 Plywood
L Bottom (1)	11 3/4 x 10 1/2 - 3/4 Plywood
M Clamp Blocks (2)	2 1/2 x 11 1/4 - 3/4 Plywood
N Lever Arm (1)	1 1/2 x 17 - 1/2 Plywood
O Lever Arm Block (1)	2 x 4 - 1/2 Plywood

## Hardware

- (36) #8 x 1 1/2" Fh Woodscrews
- (4) #8 x 1 1/2" Rh Woodscrews
- (26) #6 x 3/4" Fh Woodscrews
- (1) 3/8"-16 Threaded Insert
- (1) 3/8"-16 Threaded Rod, 24" long
- (1) 3/8" I.D. x 1/2" O.D. Nylon Spacer
- (2) 3/8" Washers
- (3) 3/8"-16 Lock Nuts
- (1) 3/8"-16 Star Knob
- (8) #12 Screw Hooks
- (4) 1/2" x 2 5/8" Extension Springs
- (7) #8 Washers
- (1) 1/8" x 9/16" x 7/8" - 36" Aluminum Channel
- (1) 1/8" x 3/4" - 36" Aluminum Bar
- (1) 1/8" x 1 1/2" - 48" Aluminum Bar
- (6) #8 x 3/8" Fh Woodscrews
- (3) #8 x 2" Rh Woodscrews
- (4) #8 x 1 1/4" Fh Woodscrews
- (1 pr.) Brass Stair Gauges
- (2) Hold-Downs w/Hardware
- (1) 3/8" x 5/4" - 32" Alum. T-Track
- (2) 1/4"-20 Threaded Inserts
- (1) Router Bit Guard
- (2) 1/4"-20 Knobs w/1 1/2"-long Studs
- (2) 1/4"-20 Knobs w/3/4"-long Studs
- (4) 1/4" Washers
- (1 pr.) 12" Drawer Slides w/Screws
- (1) 5/16"-18 x 2 1/2" Carriage Bolt
- (1) 5/16"-18 Lock Nut
- (1) 5/16" Fender Washer
- (1) 1/2" x 6" Steel Rod
- (1) 3/8" x 9 1/4" - 11 3/4" Router Plate

**ShopNotes** To download a free cutting diagram for the Mortising Machine, go to: [www.shopnotes.com](http://www.shopnotes.com)

ON-LINE EXTRAS

# Using the Mortising Machine

Now that you have your mortising machine completed, you're ready to set it up and try it out.

The first step is to position the router bit on the thickness of your workpiece. (To create a centered mortise, you'll want to center the bit on the workpiece.) Start by cutting a spacer block to fit underneath the router plate to raise the router bit to the approximate center of your workpiece, see drawing in margin.

The spacer block is just to get you in the ballpark. To fine-tune the height of the bit, turn the knob at the end of the tapered bed to raise or lower the bit until it is perfectly centered on the thickness of your workpiece, as you see in Step 1, detail 'a.'

Once you have the height adjusted, you can adjust the depth of the bit. This is just a matter of bringing the carriage all the way forward and adjusting the depth of the router and bit, see Step 1, detail 'b.'

The last adjustment to make is to set the stops on the front of the sliding table to control the length of the mortise. To do this, start by clamping the workpiece to the table so the router bit is roughly centered on the mortise. Then slide the table to the left until the bit lines up with the end of the mortise. Move the left-hand stop up against the strike plate and lock it in place. Now just repeat the process for the right-hand stop.

At this point, you're ready to start mortising. The important thing to remember is that you will be making the mortise in a series of shallow passes, see Step 3.

Start with the carriage pulled back and the table pushed all the way to the right. Turn the router on and use the lever arm to bring the carriage forward until the router bit enters the wood about 1/8". Now, slide the table all the way to the left. Next, advance the bit about 1/8" and slide the table back to the right. Then it's just a matter of repeating this process until you reach the full depth of the mortise.

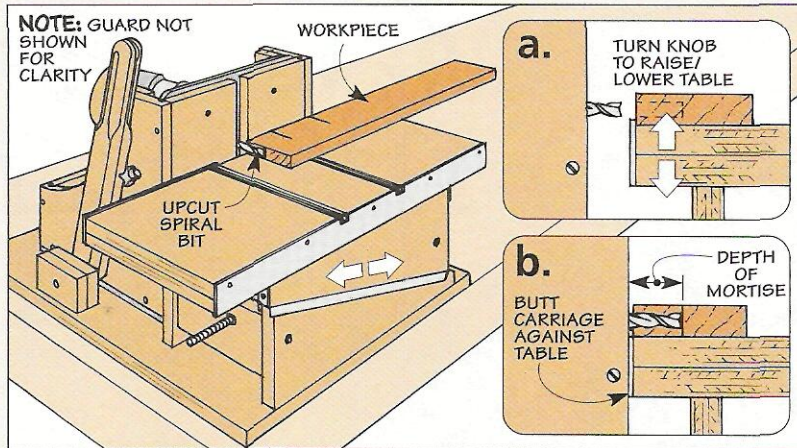

**1** Set the height of the router bit by first placing a spacer block under the router plate and then turning the knob on the end of the tapered bed. Once this is done, you can set the depth of the bit.

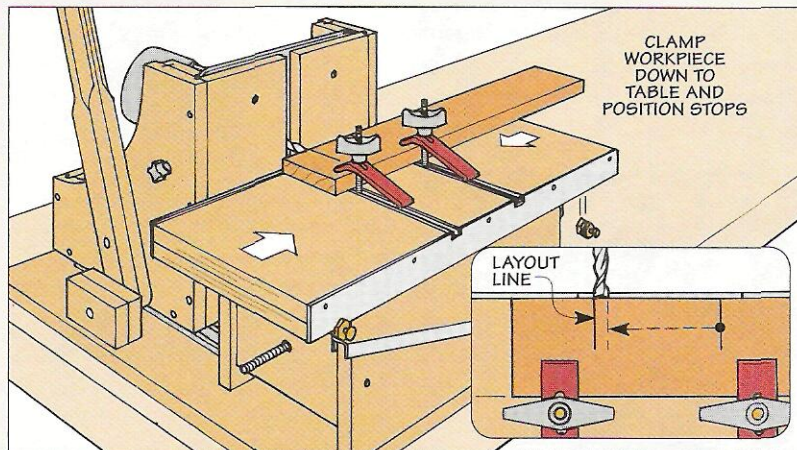

**2** With the workpiece clamped down to the sliding table, align the router bit with the ends of the mortise in order to position the stops along the front edge of the sliding table.

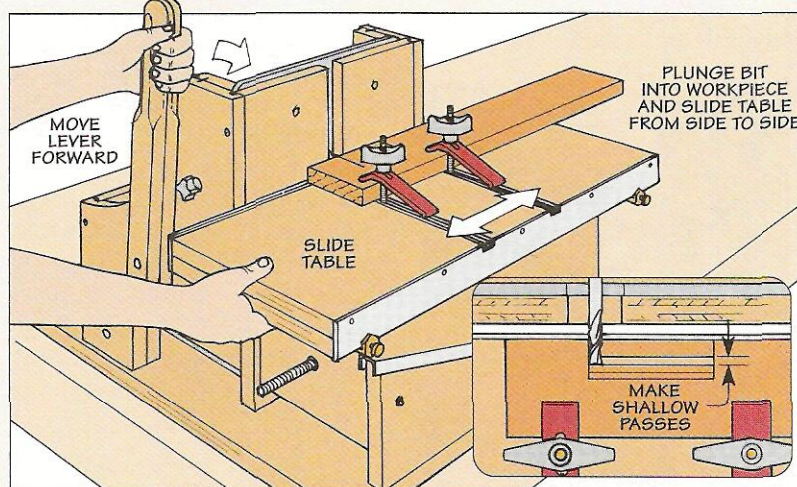

**3** Rout the mortise in multiple passes, removing about 1/8" of material each time. Use the lever arm to plunge the bit into the workpiece and then move the sliding table from side to side.

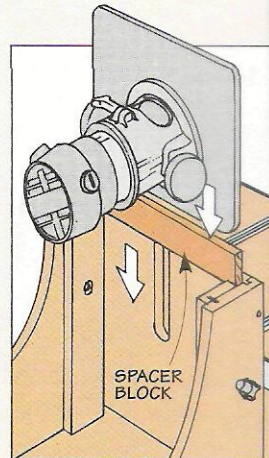

**▲ Spacer Block.** The router plate rests on a spacer block. By using different widths of blocks, you can vary the height of the router for different thicknesses of stock.

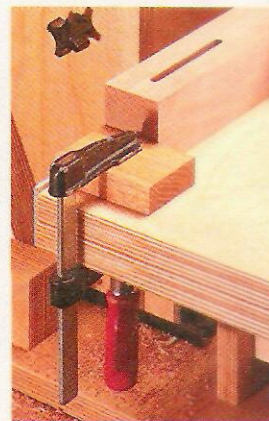

**▲ Stop Block.** To rout mortises in multiple workpieces, clamp a simple stop block to the sliding table to position all the pieces the same.

# Shop Jigs Materials & Hardware

**W**e use jigs all the time in our shop.

They make a task faster, more accurate, and safer.

Some of these jigs are made “quick and dirty” — they’re used once and then tossed out. So we don’t worry too much about what they’re made out of. But if a jig is going to see frequent and heavy-duty use, it’s best to take the time to carefully select the materials and hardware you use.

There are all kinds of materials and literally hundreds of pieces of hardware that could be used. But for our jigs, there’s really only a handful we turn to time and time again. Some are specialized enough that it’s best

comes with one fuzzy, waffle-like face.

Tempered hardboard is a great choice for the base of small jigs. That’s because you get strength and stability without limiting the depth of your cut, like you see in photo C at the bottom of the page.

In the same photo you’ll also see a part of the jig that gets chewed up during use — the backing insert. Since tempered hardboard is stiff and inexpensive, you can make a bunch of replaceable inserts for pennies — and you’ll always have some on hand.

**Medium-Density Fiberboard** — Another product that’s similar to tempered hardboard is MDF. Like hardboard, MDF is smooth, stable, and inexpensive. Plus, it comes in thicker sizes. You can use it for fences, bases, or even an entire jig, like the shooting board you see in photo D at the lower left.

One more thing to mention about MDF — it’s heavy. Which can be an advantage when you’re building a piece of shop equipment like a lathe stand (*ShopNotes* Issue No. 67). The extra weight provides stability and makes it virtually vibration-free.

But you probably don’t want to build a large jig out of MDF since it can be difficult to handle.

## PLASTICS

Like wood-based sheet goods, there’s another material that can make a jig safer, eliminate problems of wood movement, or simply make it more accurate — plastic.

**Polycarbonate/Acrylic** — Two common plastics that I use on jigs are polycarbonates (like Lexan) and acrylic (Plexiglas). What these plastics do is provide a “window” to what’s happening with the jig.

Acrylic is more commonly available and it’s what I turn to most often — except when there’s a

to order them as they’re needed. But most of the materials and hardware detailed on the next few pages are things to keep on hand all the time.

## SHEET GOODS

One of the first materials I consider for a jig is hardwood. I like it for the small parts of a jig — usually all I have to do is sift through the scrap bin to find just the right piece.

But hardwood isn’t always the best choice. There are three types of *sheet* goods I like to keep a constant supply of because one (or two) of them are used in just about every jig I make: plywood, hardboard, and medium-density fiberboard (MDF).

**Plywood** — The advantage of plywood compared to solid wood is that it stays flatter and is more stable over time — an important consideration for the fence or base of jigs like the ones shown in photos A and B.

In our shop, we typically build our jigs with hardwood plywood or, more often, Baltic birch plywood. They have more plies and fewer voids compared to construction-grade plywood. And their faces are harder and much smoother. So the jig is sure to last a long time.

**Hardboard** — Another sheet good that sees a lot of use in our shop is a *processed* wood product — hardboard. It’s made by mixing and heating wood fibers and synthetic resins. This mixture is then compressed into large, flat sheets that are stiff and strong.

Plus, hardboard is inexpensive and it comes in uniform thicknesses ( $\frac{1}{8}$ " and  $\frac{1}{4}$ "). But make sure you don’t settle for just any hardboard. For most jigs, you’ll want to use *tempered* hardboard. It’s smooth on both sides. Not like some hardboard that

*Building your own shop jigs is a great way to put some extra cash in your pocket. And by using the right materials and hardware, you won’t have to sacrifice performance or accuracy.*



▲ **Plywood.** A mainstay for long-lasting jigs, high-quality plywood (like the Baltic birch shown above) provides flatness and stability for fences (left) and bases (right).

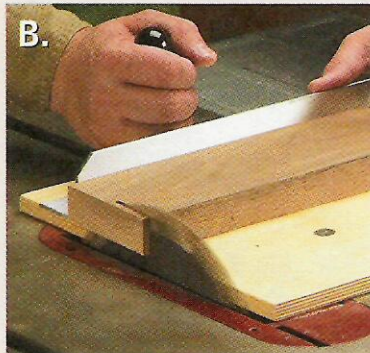

▲ **Hardboard & MDF.** Smooth and strong, hardboard (left) makes a fine, low-profile base or replaceable inserts. MDF (right) is an inexpensive way to build an entire jig.

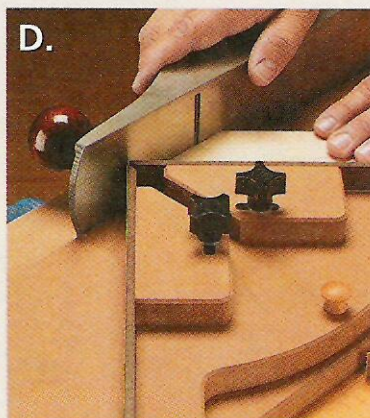

chance it could get hit by a bit, blade, or workpiece. Since acrylic is brittle, it can easily shatter. So for the amber-colored guard you see in photo E at right, polycarbonate is a better choice. It serves as a constant reminder to keep my hands away from the saw blade when making the cut — yet still be able to see the cut.

In photo F, you can see how a small piece of Plexiglas can be used as an accurate indicator simply by scoring a “hairline” in the surface.

**Phenolic** — Another plastic product I really like is phenolic. Like hardboard, phenolic is made in a two-step process. First, layers of paper are coated with a resin. Then the paper and resin are squeezed in a heated press to a uniform thickness.

In the end, the phenolic comes out very hard and smooth. And it doesn't absorb moisture, so it won't shrink or swell. So you can use it for runners on the base of jigs. Plus, it's incredibly strong and stiff. That makes it a perfect choice as a mounting plate for a router, like you see in photo G at right.

Unfortunately, phenolic isn't perfect. For one thing it can be rather expensive — and difficult to find. I typically order it through the mail from one of the many woodworking catalogs available (refer to the sources listed in the margin on page 35).

**Laminate** — A lot of times you don't need an expensive piece of thick phenolic to get a hard, smooth surface. When that's the case, you can turn to plastic laminate.

The process for making laminate is similar to that for phenolic, but laminate is much thinner. The advantage of this is you can attach it to any surface. On the platen for the edge sander shown in photo H, the laminate was glued to a piece of hardboard and then screwed in place. It provides an easily replaceable, long-wearing surface.

Another advantage is laminate is much more common. You can find it at just about any home center in a variety of sizes and colors. And since it's quite inexpensive, it's a good idea to keep a supply on hand.

**UHMW** — Whenever I need an almost friction-free surface, I like to use a material called ultra-high molecular weight (UHMW) plastic. The thing that makes UHMW so slick is its self-lubricating property. Parts slide along like they're on ice. But it's not as fragile as ice — it's a tough, dense material that is very stable so it won't bind (or get sloppy) with changes in humidity.

This makes it ideal for use as a runner in the miter slot of a table saw (see photo I at right). It even comes in thin, self-adhesive strips that work great as a facing for an auxiliary fence, as in photo J.

Like phenolic, you won't find UHMW at the local home center or hardware store. But it is available from a number of mail-order sources.

**METAL**

One last material I've been turning to more often these days when building a jig is metal. And I'm not talking about screws and bolts (there's more on them later).

**Aluminum** — The metal of choice for jigs is aluminum — for a number of reasons.

First, it's strong. So your jig will last. And it's lightweight, so it won't make a jig that's too heavy or hard to handle. Aluminum is also inexpensive — it

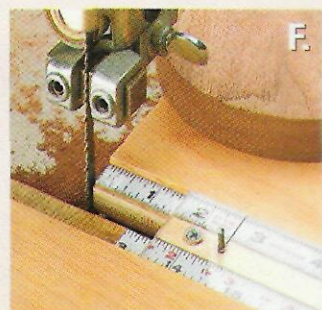
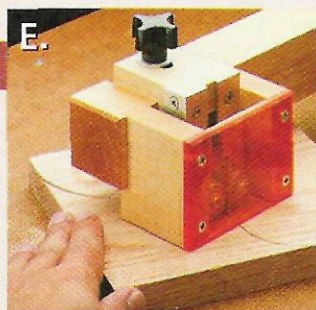

▲ **Polycarbonate & Acrylic.** Virtually unbreakable, polycarbonate is best for see-through guards (left) while inexpensive acrylic makes a great hairline indicator (right).

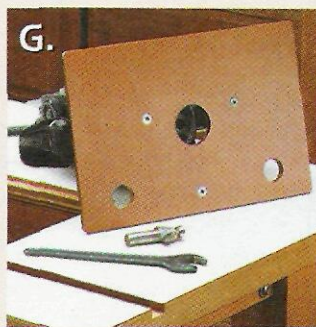

▲ **Phenolic & Laminate.** A phenolic plate is the perfect choice for mounting a router (left). And laminate makes a long-wearing and easily replaceable platen for an edge sander (right).

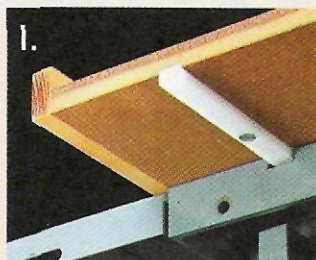

▲ **UHMW.** Jigs slide easily when they're guided by a runner (left) made from UHMW. And a workpiece will slide just as easily by adding a thin strip of UHMW (right) to an auxiliary fence.

won't cost a lot to use it in your jigs. Finally, aluminum is easy to work with. It cuts easily with a hacksaw. Cleaning up the edges is just a matter of a little file work and sanding.

But what's really nice is aluminum comes in a variety of shapes and styles. You can buy flat stock, angle, and U-channel. So finding just the right piece you need for a jig is easy.

A simple piece of flat stock was used to make a strong, lightweight stop on the miter gauge fence shown in photo K at left. And since it's so easy to work with, we used it as the base for a shop-made scratch stock (see photo L). Finally, to see how we used aluminum as part of our easy-to-use mortising machine, refer to page 12 for details.

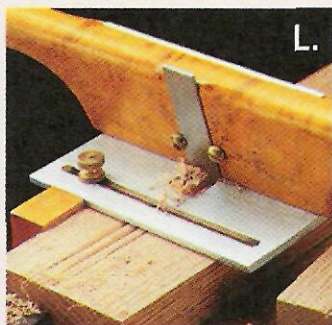

▲ **Aluminum.** Whether it's just a piece of flat stock for a stop block (left) or a piece of angle for the body of a shop-made tool like the scratch stock (right), aluminum is easy to use and work with.

# Hardware

Look through any woodworking catalog and you'll find pages and pages of hardware — fasteners, handles, knobs, and hundreds of other items. The nice thing is they're an inexpensive way to make a jig better and easier to use. Here are a few of my favorites.

## CARRIAGE BOLTS

One piece of hardware that's easy to overlook is a simple carriage bolt. When combined with a knob, it's a simple way to hold two parts of a jig together, as in the jig in photo M.

Since carriage bolts come in a wide variety of sizes, you can easily find just the right one to suit your needs. (I keep 1/4"-dia. and 5/16"-dia. bolts in various lengths on hand.)

Carriage bolts work great when the bolt can stay in one spot. The advantage of a carriage bolt is that the square shank below the capped head keeps the bolt from turning.

But carriage bolts don't work as well in soft materials. The material around the squared part of the head can round over or the head can pull through the material. To get around this, you can switch to a different type of hardware — T-nuts and inserts.

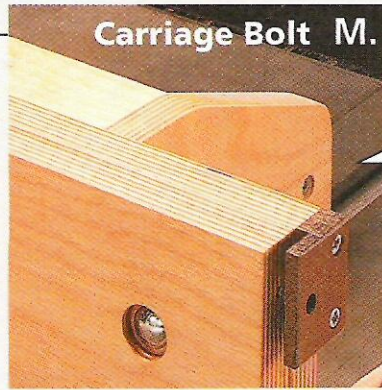

Carriage Bolt M.

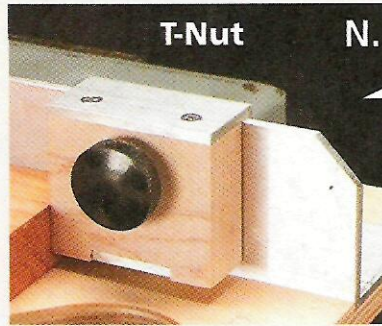
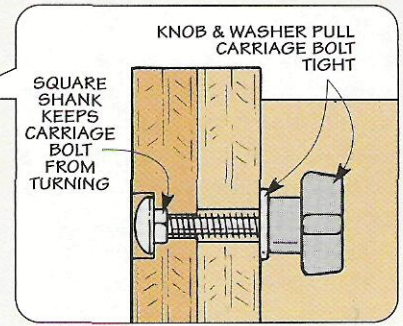

T-Nut N.

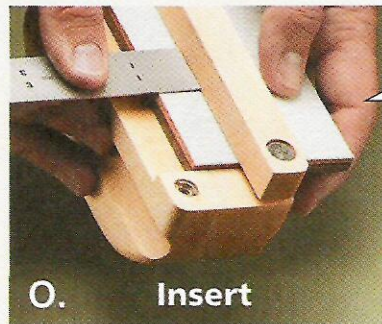
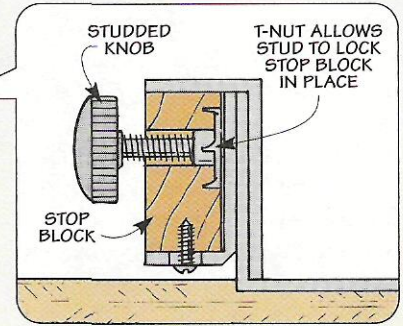

O. Insert

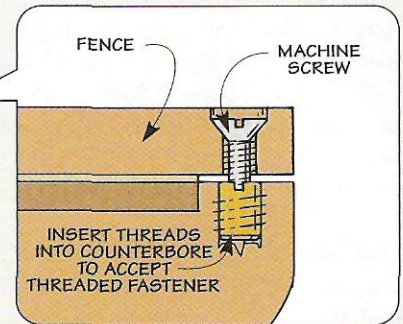

## T-NUTS & INSERTS

T-nuts are metal fasteners with large flanged heads. Located on the flange head are raised points to spear the wood and keep the T-nut from turning. (Some T-nuts have small holes for installing brads.)

Since the flange is large, the T-nut won't crush the wood. So they work well in soft materials and plywood. But they also work great when you need a countersunk, low-profile "nut" for a stop block, as shown in photo N and the detail above.

Simply back out as you tightened the screw. But an insert wants to "thread" itself further in. So it's more secure.

But inserts do have their limits. I typically don't use them in plywood. The outer threads don't grip the plies as well as I'd like. And they can be difficult to screw into some solid woods like maple.

**Insert** – An alternative to a T-nut is an insert. It's a small piece of hardware with double threads. On the outside are coarse threads to hold the insert in the wood. And on the inside are threads that fit a bolt or screw.

What makes them unique is they can be used to exert downward pressure. The sanding block shown in photo O above is a good example. A T-nut would

## KNOB

Sometimes it's the last thing you add to a jig you've made that makes it even more useful — knobs. They come in so many different sizes and shapes, there's probably one for just about any need you can come up with. Once again, there are a few I keep on hand that are used over and over.

**Captured Knob** – Any time you lock down part of a jig, it's easy to rap

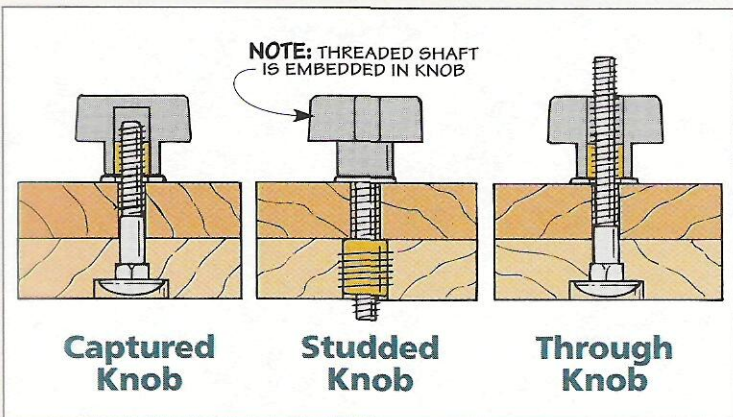



your knuckles against an exposed bolt. A captured knob has an insert embedded inside that fits over the end of the bolt and covers it up (see lower left drawing on opposite page).

This type of hardware works fine for a stop block where the total movement is limited. But the drawback to a captured head is that the bolt may bottom out before the knob is tightened down completely.

**Studded Knobs** – To solve this problem, you can turn to a knob with a stud (threaded shaft), like you see at the bottom of the opposite page. The studs are embedded in the knob when it's manufactured.

Studded knobs come in a number of different lengths. Although you can cut the stud to whatever length you need, it's a good idea to keep a few different lengths on hand.

**Through Knobs** – But there's a small problem. Studded knobs are typically only 1" to 1½" long. So when the thickness of what you're clamping varies quite a bit, it's better to switch to a through knob and a carriage bolt, as in the lower drawing on the opposite page.

Like a captured knob, a through knob has an insert embedded inside to accept the threads of the carriage bolt (or other fastener). But a hole in

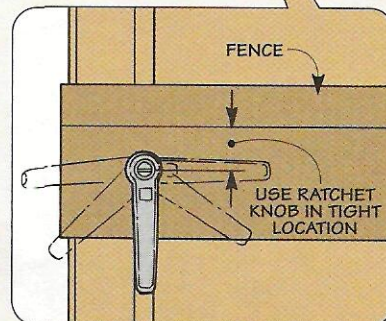
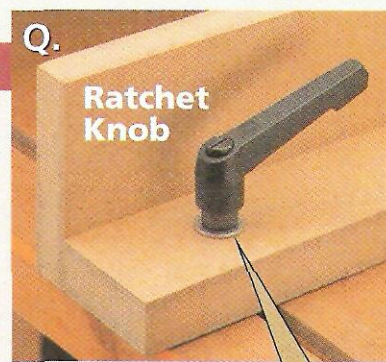
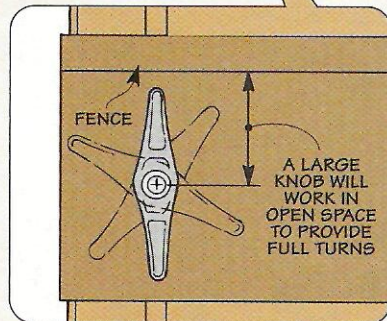
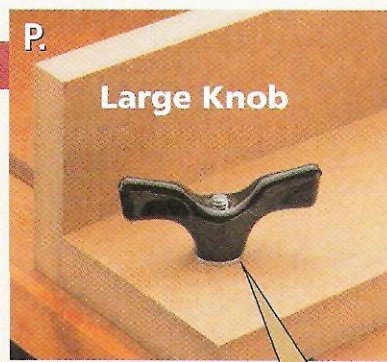

the top of the knob means you can use any length of fastener.

**Ratchet Knob** – In most cases, any of the knobs mentioned will work. This way, you can even use a large knob to get a good grip and make full turns, like you see in photo P above. But in tight situations, I turn to a ratchet knob, see photo Q. It's an *adjustable* knob with a large handle that can be tightened (or loosened) in close corners.

By lifting up on the spring-loaded handle, you can ratchet the handle back and forth until it's tight.

Note: Ratchet handles come in studded or captured versions (to use with a threaded fastener).

## T-TRACK

Knobs and fasteners don't always have to stay in one spot. An easy way to make a jig adjustable is to use knobs, fasteners, and a piece of hardware called T-track. (See the box below for more information).

You won't find T-track at the local hardware store. But there are a number of woodworking catalogs and stores that carry it (see page 35).

## Aluminum T-Track

T-track is a great piece of hardware for building jigs that are accurate *and* adjustable.

T-track is available in varying lengths and fastens in place with a few screws that pass through the bottom of the T-track. (Note: T-track varies in thickness, so be sure to design your jig to accommodate it.) For shorter lengths, you can easily cut the T-track with a carbide-tipped saw blade or a hacksaw.

Regardless of the manufacturer, all T-track operates on the same basic principle. A slot in the track accepts a flange (or toilet) bolt (upper photo) or the head of a hex bolt (lower photo).

By slipping an accessory (like a stop block) over the bolt, you can position it anywhere simply by sliding it along the track. Locking it in place is just a matter of tightening the knob.

### Flange Bolt Style



### Hex Bolt Style



# Roll-Around Shop Cart

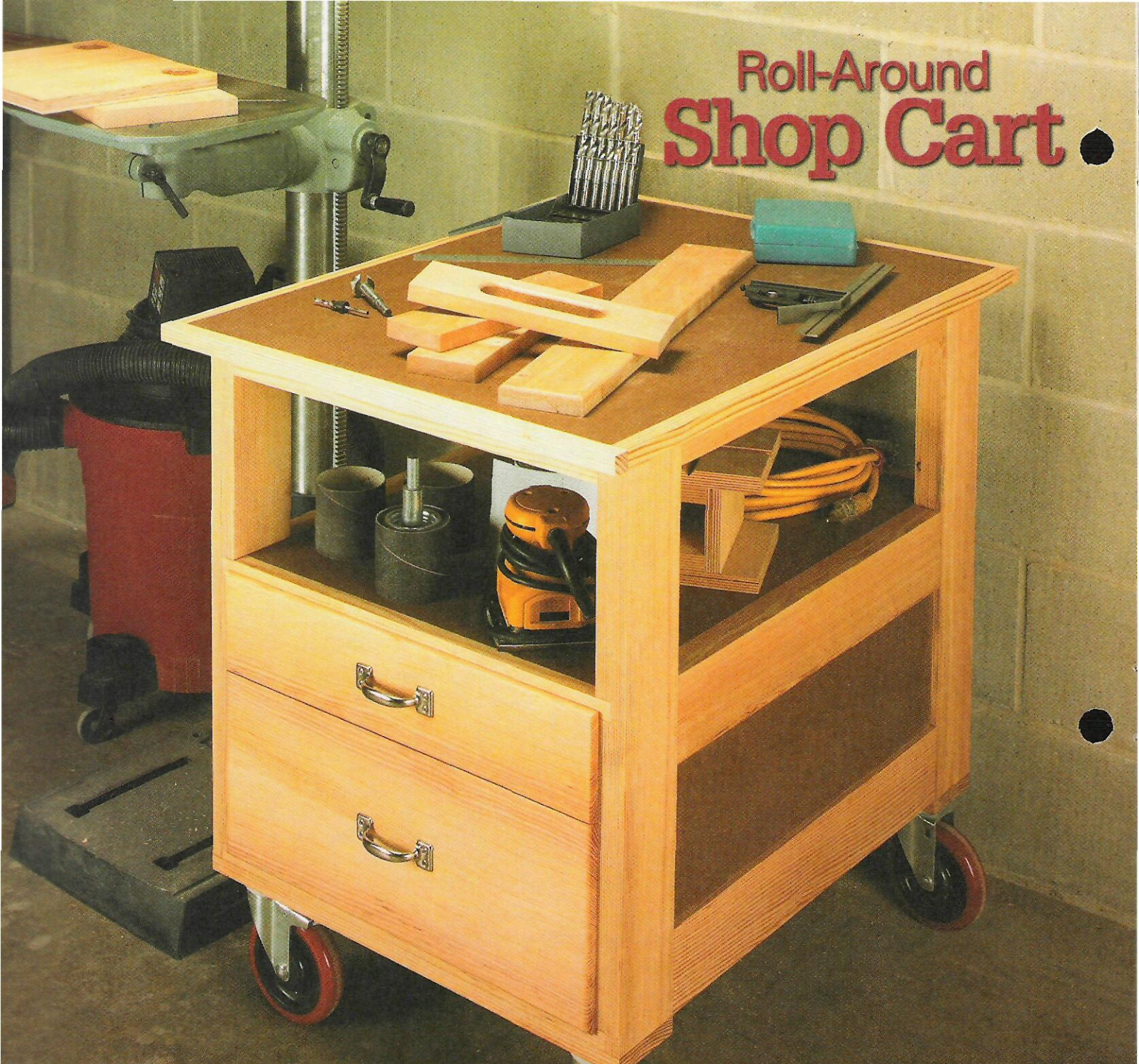

One thing that always comes in handy around the shop is an extra helper. Someone to carry parts around or just be “at the ready” whenever the need arises.

Unfortunately, not many of my friends want to hang around the shop waiting for me to need them. That’s what led to building the roll-around shop cart shown above. Whether you’re moving parts around the shop or working with a number of workpieces at one tool, you’ll always have a “helper” who’s ready, willing, and able to lend a hand.

**Worksurfaces** – One thing you’ll notice is that the cart has two separate worksurfaces. The top holds workpieces that are ready to be worked on (like the lumber

being planed in the photo at right). And the lower surface stores completed workpieces. The upper surface also works great as an assembly or finishing area (see photo at far right).

Regardless of the workout you give this cart, when you’re ready to “roll on” to the next task, you won’t have to worry about spilling a load of workpieces. That’s because the cart rolls on large, heavy-duty casters that won’t get hung up on extension cords, floor cracks, wood chips, or debris.

**Storage** – This roll-around cart also offers plenty of storage. A pair of drawers at the front of the cart and an open shelf at the back means you won’t have to search for often-used supplies. They’ll always be close at hand.

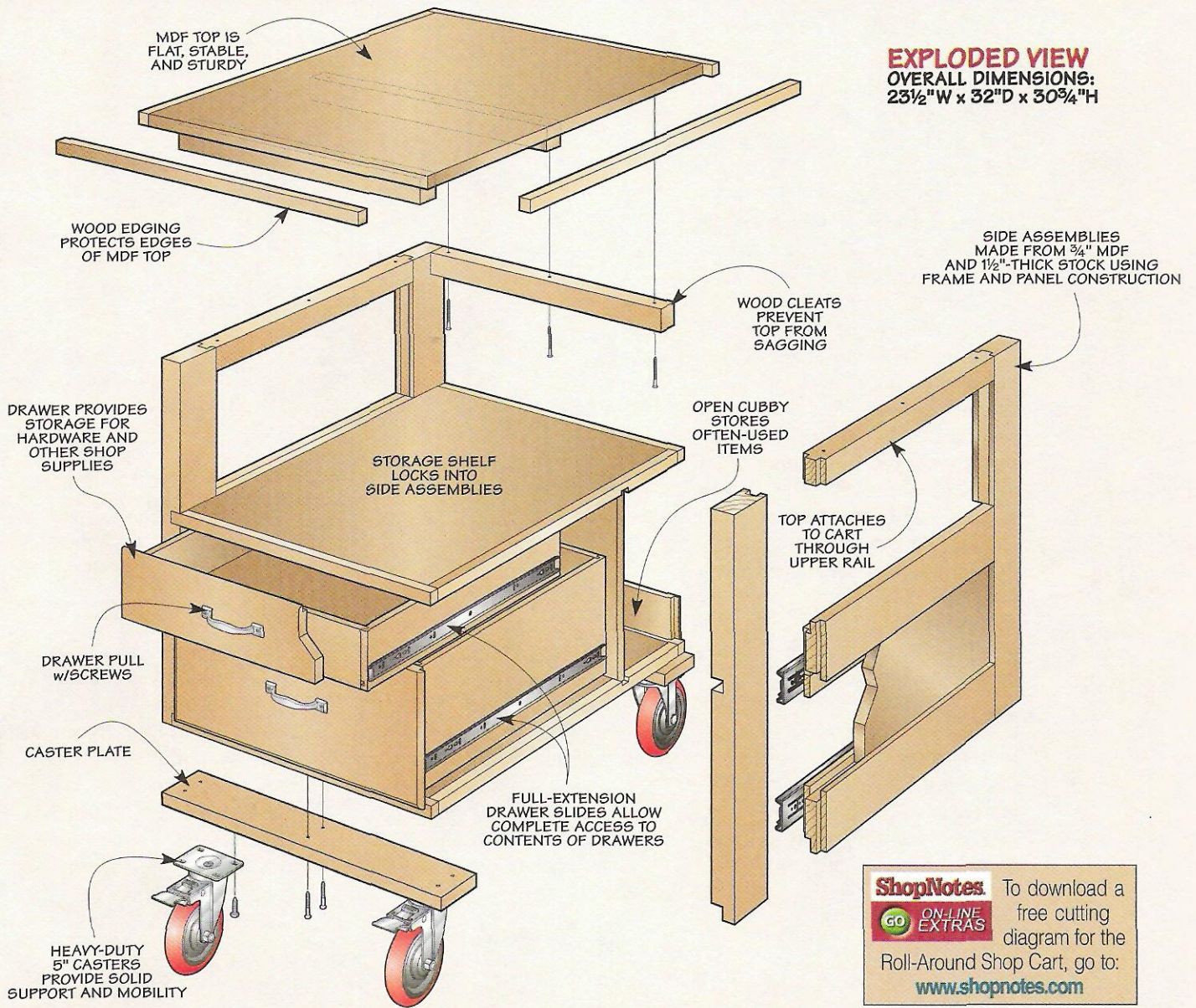

**ShopNotes** To download a free cutting diagram for the Roll-Around Shop Cart, go to: [www.shopnotes.com](http://www.shopnotes.com)

**go ON-LINE EXTRAS**

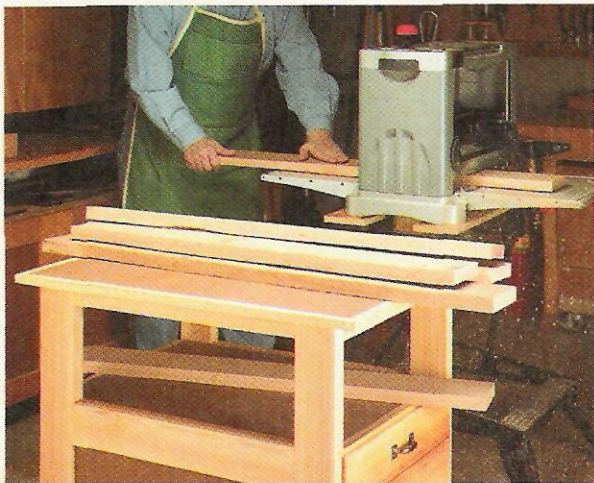

▲ **Multiple Worksurfaces.** Whether you're working at the table saw, jointer, or planer (shown above), the lower shelf is the perfect place to store completed workpieces.



▲ **Assembly Station.** When you're not moving parts around the shop, the generously sized top makes a perfect assembly or finishing station for smaller projects.

# Base & Top

I started on the roll-around shop cart by building the base. It's basically just a big box made up of two frame and panel assemblies joined by a shelf and bottom panel.

**Material** – Since I expected the cart to see heavy-duty use around the shop, I decided to use construction-grade (“two-by”) lumber for the frame pieces. (I used Douglas fir.) Construction lumber has a few things going for it. First, it's beefy and heavy — a perfect choice for a shop cart. And it's fairly inexpensive.

But construction lumber does have a couple drawbacks — which are easy to overcome. For one, you'll have to spend a little time picking through the stack of lumber. I like to separate out the lumber with the straightest grain, fewest knots, and minimal defects. Then I select lumber wider than what I need. This way, I can trim off the rounded edges to square it up and cut around any remaining knots or defects.

One last thing. Construction lumber often has a high moisture content (the lumber I picked out was sitting outside).

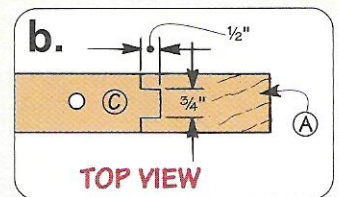
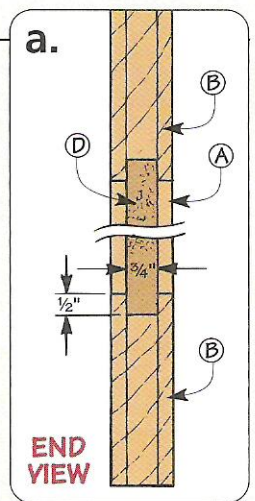
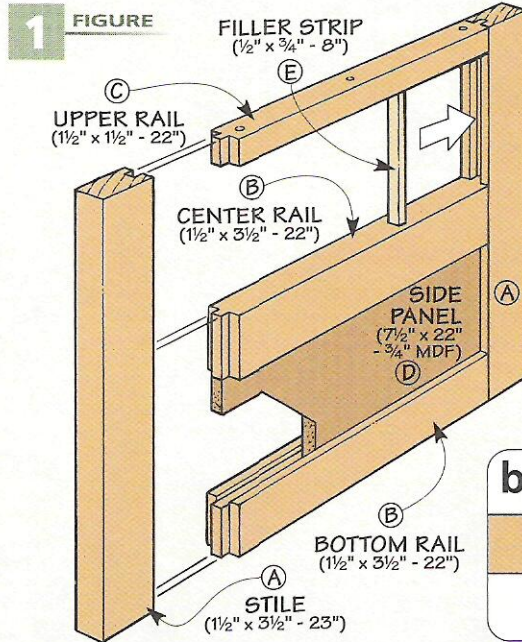

So once you get it back to your shop, it's a good idea to sticker it and let it dry out before you start cutting any workpieces to size. Note: Sticker is just a fancy word for propping

strips of scrap lumber so air can circulate around it. After the stock has had a chance to dry out for a few weeks, you're ready to start cutting.

**Side Assemblies** – Once the stock is ready, you can reference Figure 1 for the dimensions needed to build the side assemblies for the base. Each side assembly starts out

2 FIGURE

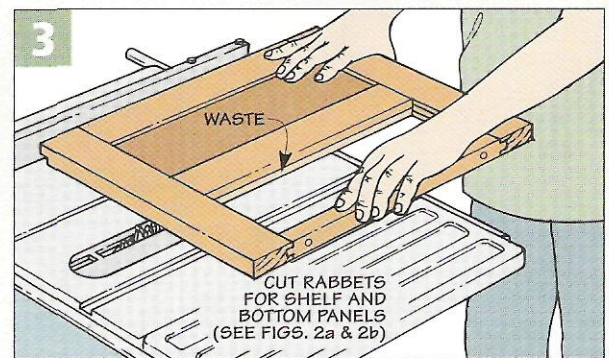
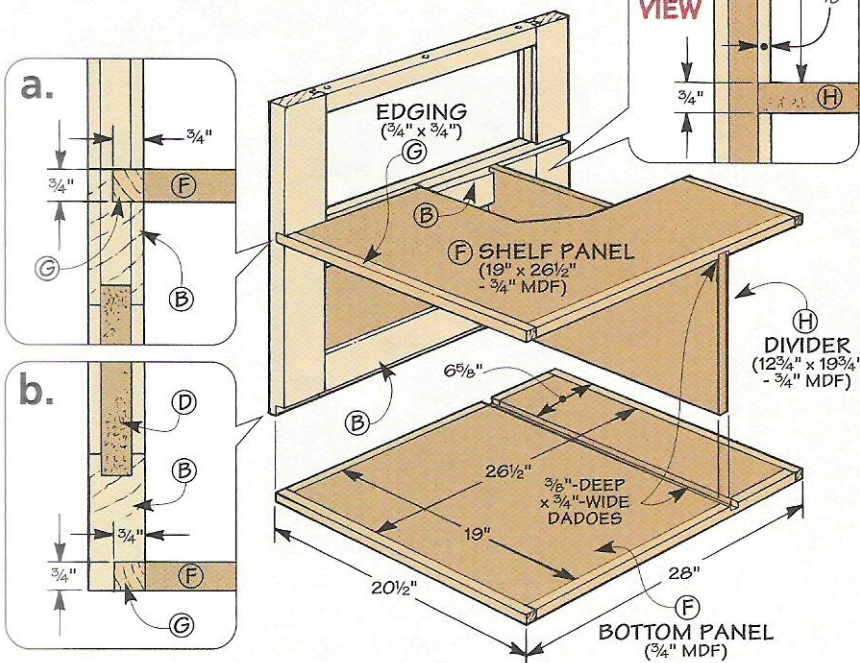

as a frame made up of a pair of *stiles* (A) and three *rails* (B, C). Note: The upper rail is narrower to provide a larger opening to the lower shelf and make it easier to attach the top later with shorter screws.

With the frame pieces sized, you can turn your attention to the tongue and groove joints that hold the frame together. You can see in Figure 1a that the centered grooves are sized to fit the  $\frac{3}{4}$ " MDF *side panel* (D). Then you can cut the tongues on the ends of the rails to match the grooves.

**Assembly** - With the joinery complete, you're just about ready to glue up each side assembly. But before you do that, it's a good idea to drill a set of three holes in each upper rail for mounting the top later (Figures 1 and 1b).

To glue up each frame, I started with one stile and fit the bottom rail in place. After adding the side panel and center rail, slip the upper rail in place so it's flush with the end of the stile. All that's left is to add the other stile and then clamp up the assembly so it's flat and square.

**Filler Strips** - To fill in the open grooves on the inside face of the stiles, I added some *filler strips* (E), like you see in Figure 1. I like to size them so they're a bit proud. This way, I can sand them perfectly flush once they're glued in place.

**Shelf & Bottom Panel** - At this point, you can set the frame and panel

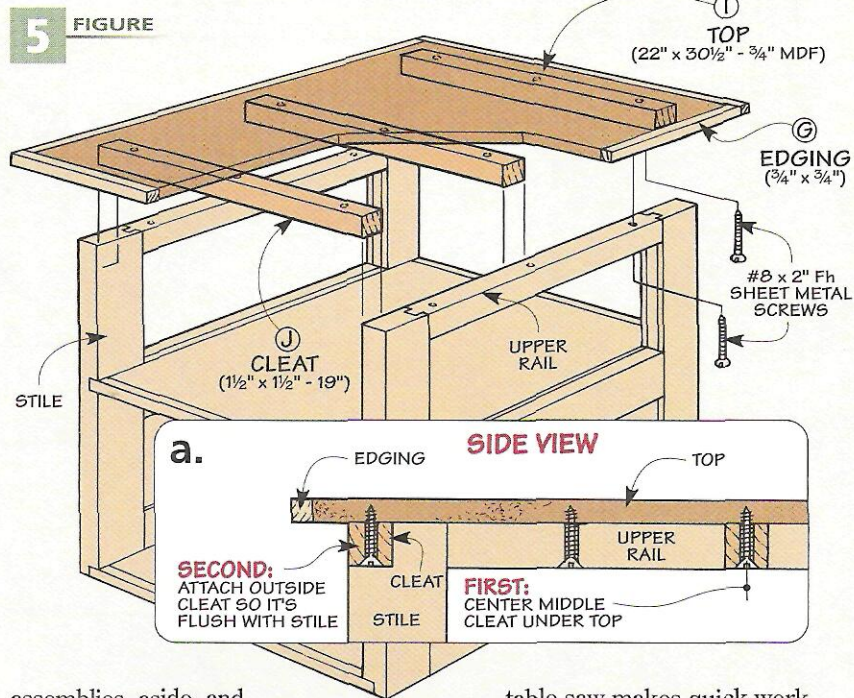

assemblies aside and turn your attention to the shelf and bottom panel. These two pieces join the side assemblies together to form the base of the cart.

The *shelf* and *bottom panel* (F) are made from  $\frac{3}{4}$ " MDF and are wrapped with  $\frac{3}{4}$ "-thick *edging* (G), as in Figure 2. Here again, I find it easiest to glue edging in place so that it's a bit proud and then sand it flush.

As you can see in Figure 2, the bottom panel fits into a rabbet cut along the lower inside edge of each side assembly (Figure 2b) and the shelf fits into a "rabbet" cut along the top inside edge of the center rail (Figure 2a). A dado blade in the

table saw makes quick work of cutting both rabbets, as illustrated in Figure 3.

Before you can assemble the cart, there's one last thing to do. And that's to cut dados in the side assemblies, shelf, and bottom panel (Figure 4). These dados trap in place a  $\frac{3}{4}$ " MDF *divider* (H) that separates the drawer compartment from the storage area at the back of the cart (Figure 2). Note: You don't need to cut the dados in the *upper rails*.

**Assemble Base** - Once the dados are cut, you can assemble the base of the cart by gluing the shelf and bottom into the side assemblies, trapping the divider in place as you do this (Figure 2).

**Top** - Like the shelf and bottom panel, the *top* (I) is just a piece of  $\frac{3}{4}$ " MDF wrapped with *edging* (G). Since I was a bit worried about the MDF top sagging over time, I "beefed" it up by screwing a set of  $1\frac{1}{2}$ "-square *cleats* (J) to the bottom side, as seen in Figures 5 and 5a. After positioning the top on the base of the cart, I screwed it in place (Figure 5).

**Casters** - Finally, to make the cart mobile, I added casters to the bottom. To provide solid support, they're attached to *caster plates* (K) that are glued and screwed to the bottom of the cart (Figures 6 and 6a).

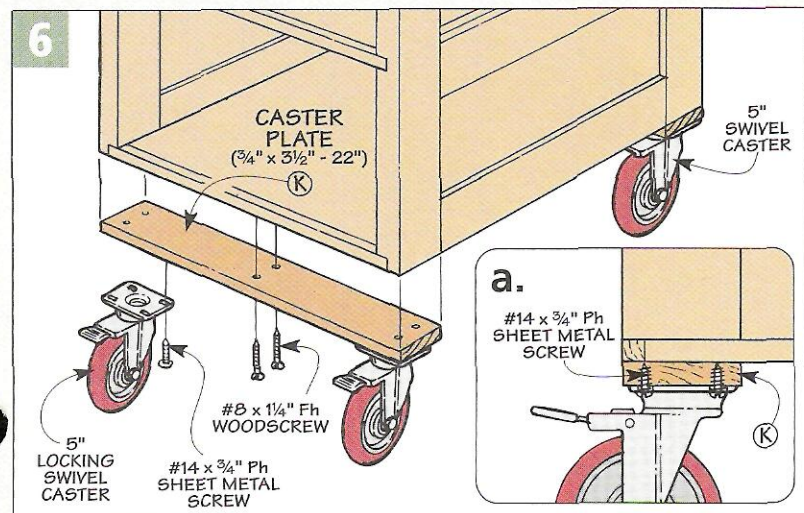

# Drawers

## 7 OVERVIEW

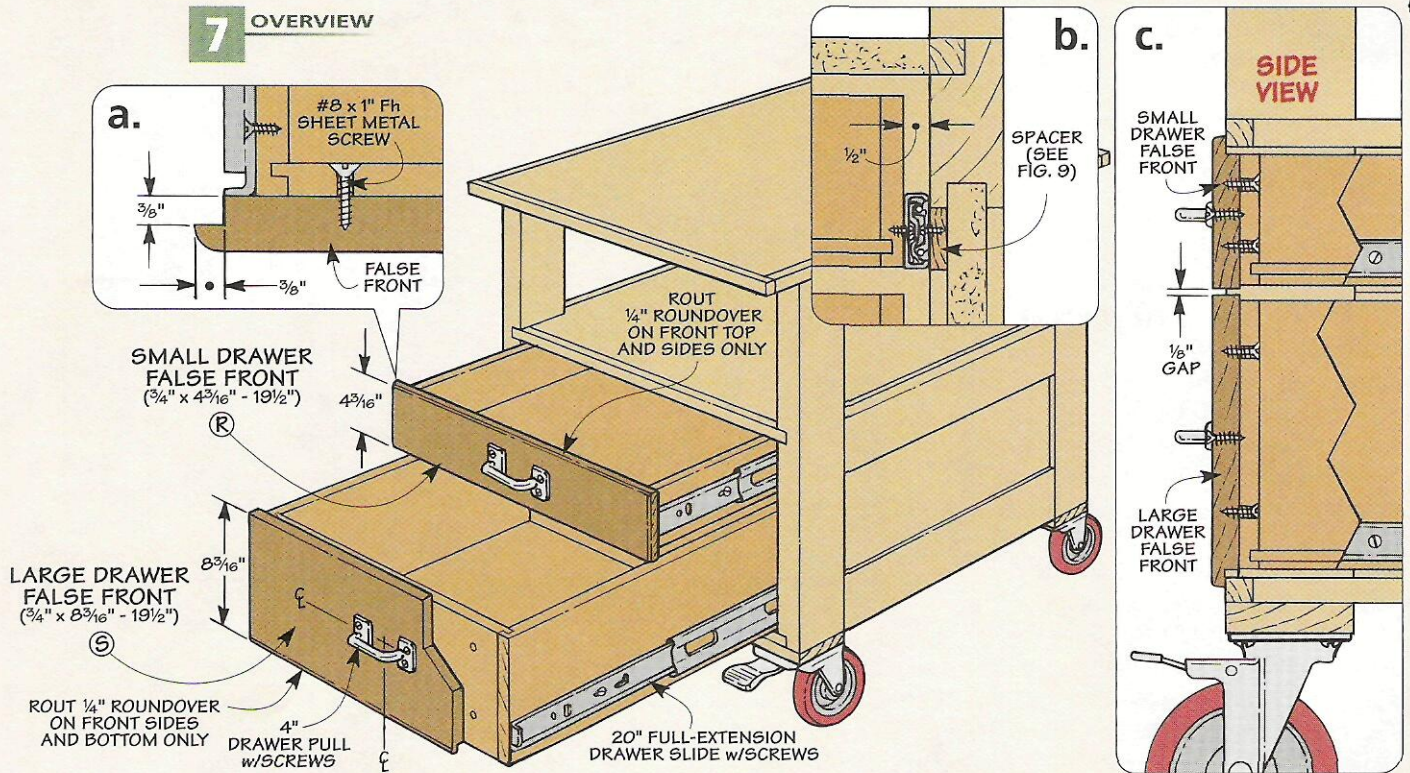

With the base of the cart complete, you're ready to add the two drawers, as shown in Figure 7.

**Size Drawers** – Although I could have made the two drawers the same size, I decided to make one shallow drawer and one deep drawer. This way, I could store a wider variety of tools and supplies.

Besides keeping the height in mind as you size the parts, you'll also need to consider how you're going to mount the drawers inside the base. As you can see in Figure 7, I used full-extension, metal drawer slides.

If you're wondering why I purchased metal slides for a utility shop cart, there are a couple good reasons.

First, metal slides are strong — an important feature for a drawer loaded with heavy shop tools and supplies. And second, the full-extension feature ensures you'll be able to reach the entire contents of the drawer easily.

For the slides I used, I had to allow for 1/2" of clearance on each side of the drawer (Figure 7b). After allowing for this clearance and the

tongue and dado joinery used to hold the drawers together, I cut the 1/2"-thick drawer fronts, backs (L, N) and sides (M, O) shown in Figure 8 to size.

The nice thing about the tongue and dado joinery for the drawers is that you can cut it entirely on the table saw. A 1/4"-wide dado cut on the ends of each side accepts a tongue cut on the ends of the fronts and backs, as in Figure 8b.

Before assembling the drawers there are a couple things to do. First, you'll need to cut a groove near

## 8 FIGURE

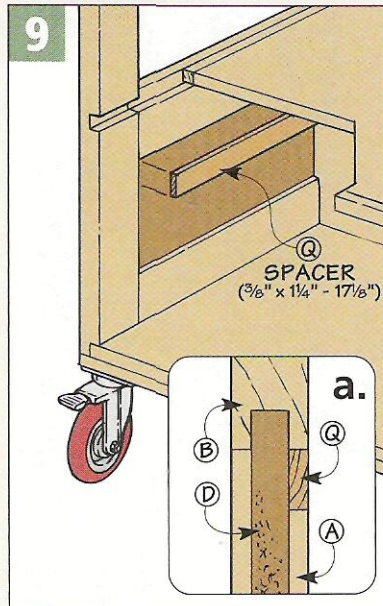
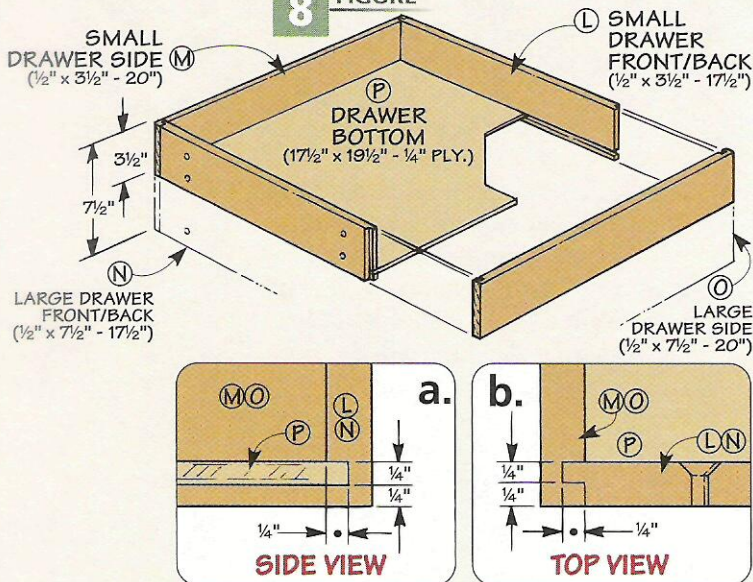

the bottom edge to hold the 1/4" plywood *bottom (P)*, as in Figure 8a. And second, I've found when making drawers it's easiest to drill holes for mounting the false fronts *before* assembly (Figures 8 and 8b).

**Spacers** – After gluing up each drawer, there's one last thing to do before installing them. And that's to add a couple spacers to the inside of the cart. The *spacer (Q)* fills out the side assembly to provide a smooth, even surface for installing the drawer slides, as in Figures 9 and 9a.

**Install Drawers** – After gluing the spacers in place, you're ready to install the drawers. To install the full-extension, metal slides, you'll need to separate each one into two parts. Then you can screw one half to the

cart and the other half to the drawer so the slides are flush with the bottom edge of each drawer (Figure 7b). Note: The half of the slide installed in the cart is set back 3/8" to allow for the lip of the false fronts that are added next (Figure 7a).

**False Fronts** – With the drawers in place, all that's left to complete them is to add some rabbeted *false fronts (R, S)*. The rabbets make it easy to install the false fronts so they're perfectly aligned.

When sizing the false fronts, allow for a 1/4" overlap on the top, bottom, and sides, and an 1/8" gap between the drawers. Then you can rabbet the *top* and sides of the small false front, and the *bottom* and sides of the large false front. (There are no rabbets where the false fronts meet.)

To ease the edges of the false fronts, I rounded over the outside face of the same edges that were rabbeted, as you can see in Figure 7.

Now, you can screw the false fronts to the drawers. Then center a pull on each false front and screw it in place, as you see in Figure 7.



▲ **Storage Cubby.** Adding a "false front" to the opening at the back of the cart creates a handy storage area for often-used items.

**Cubby** – All that's left at this point is to install a "false front" to form the cubby at the back of the cart, as you can see in the photo above.

Like the large false front, the *cubby front (T)* is rabbeted to form a lip and rounded over on the bottom and ends (Figures 10a and 10b). Then, it's simply glued in place.

**Finish** – After wiping on a couple coats of an oil finish, your new "helper" will be ready to lend a hand in the shop. The nice thing is, he won't need a break, and you won't hear any complaints. 🛠️

### Hardware

- (8) #8 x 1" Fh Sheet Metal Screws
- (12) #8 x 1 1/4" Fh Sheet Metal Screws
- (15) #8 x 2" Fh Sheet Metal Screws
- (16) #14 x 3/4" Ph Sheet Metal Screws
- (2 pr.) 20" Full-Extension Drawer Slides w/Screws
- (2) 4" Drawer Pulls w/Screws
- (2) 5" Locking Swivel Casters
- (2) 5" Swivel Casters

### Materials

#### Cart

- |                           |                           |
|---------------------------|---------------------------|
| A Stiles (4)              | 1 1/2 x 3 1/2 - 23        |
| B Center/Bottom Rails (4) | 1 1/2 x 3 1/2 - 22        |
| C Upper Rails (2)         | 1 1/2 x 1 1/2 - 22        |
| D Side Panels (2)         | 7 1/2 x 22 - 3/4 MDF      |
| E Filler Strips (4)       | 1 1/2 x 3/4 - 8           |
| F Shelf/Bottom Panel (2)  | 19 x 26 1/2 - 3/4 MDF     |
| G Edging                  | 3/4 x 3/4 - 25 Ln. Ft.    |
| H Divider (1)             | 12 3/4 x 19 3/4 - 3/4 MDF |
| I Top (1)                 | 22 x 30 1/2 - 3/4 MDF     |
| J Cleats (3)              | 1 1/2 x 1 1/2 - 19        |
| K Caster Plates (2)       | 3/4 x 3 1/2 - 22          |

#### Drawers

- |                                |                            |
|--------------------------------|----------------------------|
| L Small Drawer Front/Back (2)  | 1/2 x 3 1/2 - 17 1/2       |
| M Small Drawer Sides (2)       | 1/2 x 3 1/2 - 20           |
| N Large Drawer Front/Back (2)  | 1/2 x 7 1/2 - 17 1/2       |
| O Large Drawer Sides (2)       | 1/2 x 7 1/2 - 20           |
| P Drawer Bottoms (2)           | 17 1/2 x 19 1/2 - 1/4 Ply. |
| Q Spacers (2)                  | 3/8 x 1 1/4 - 17 1/8       |
| R Small Drawer False Front (1) | 3/4 x 4 3/16 - 19 1/2      |
| S Large Drawer False Front (1) | 3/4 x 8 3/16 - 19 1/2      |
| T Cubby Front (1)              | 3/4 x 3 1/8 - 19 3/4       |

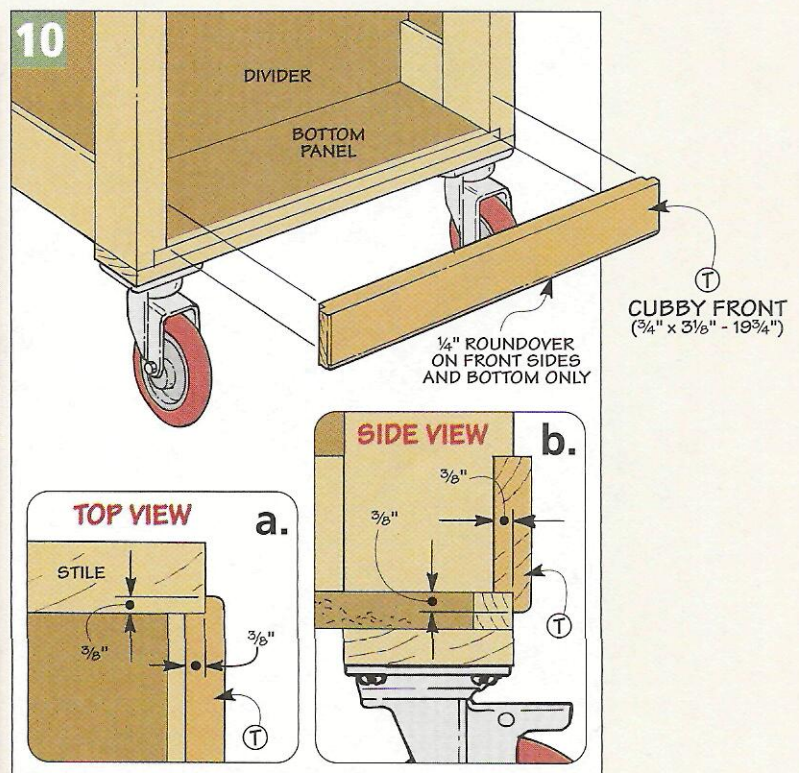

# Shop Talk

*Fine tune your machinery and your woodworking by adding a dial indicator to your set of tools.*

**W**ord gets out quickly when a new tool shows up around here. So it wasn't surprising when several people just happened to show up in the shop as I was checking out a new dial indicator.

At first they took turns pushing the spring-loaded shaft in and out, watching the needle spin around like a clock in overdrive. Then the questions started flying. How accurate is it? What's it cost? And the most important question, what can I use it for?

For a quick and dirty demonstration, I set the dial indicator on top of the table saw and then adjusted the position of the indicator so the contact point of the shaft was resting against the table.

After loosening the knob holding the bezel in place (see photo above) and "zeroing out" the dial — I slid a sheet of paper under the tip. The needle jumped like an earthquake had just hit. Even though the paper was only four thousandths of an inch (0.004") thick, it was *easy* to see this

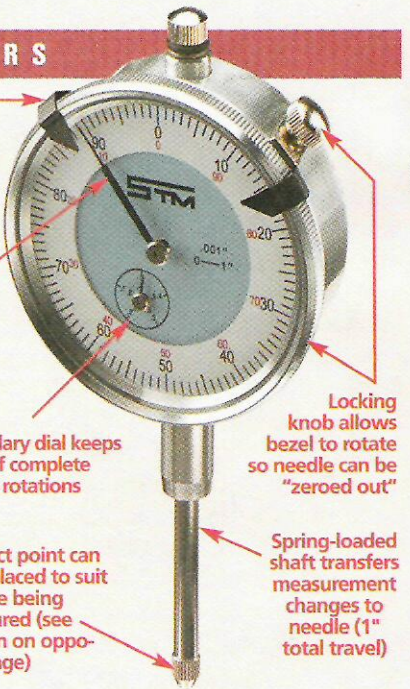

## Dial Indicator

amount because the dial accurately reads changes as small as 0.001".

**Accessories** — To accomplish this, I did need more than just the dial indicator. Taking full advantage of its capabilities requires a couple "must-have" accessories. The first is a magnetic base like the one you see at the top of the opposite page.

Regardless of what you want to measure, you can twist and turn the arms of the magnetic base to position the dial indicator right where you need it. And if you need to lock the base in place, all you have to do is flip the switch on the base and the magnet grabs a steel or cast iron surface like it's been nailed in place.

The lower margin on the opposite page shows a second accessory to consider buying — a set of contact points. The contact point can easily be changed to ensure you'll have the right tip for the task at hand.

But don't worry that a dial indicator and a couple accessories will cost a lot. The dial indicator was less than \$20, and the two accessories were just under \$30. (For sources, refer to page 35.)

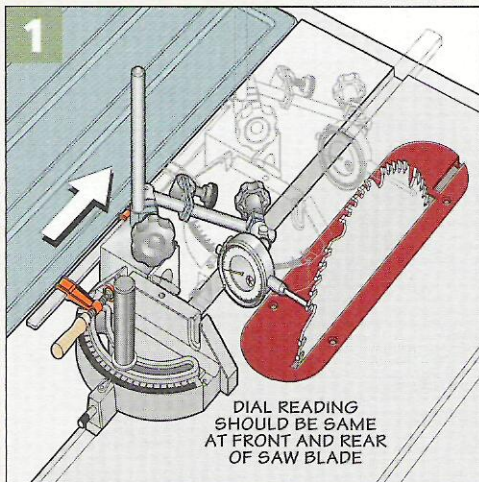

▲ **Miter Slot.** Identical readings at both the front and rear of the saw blade ensure the miter slot and blade are perfectly aligned.

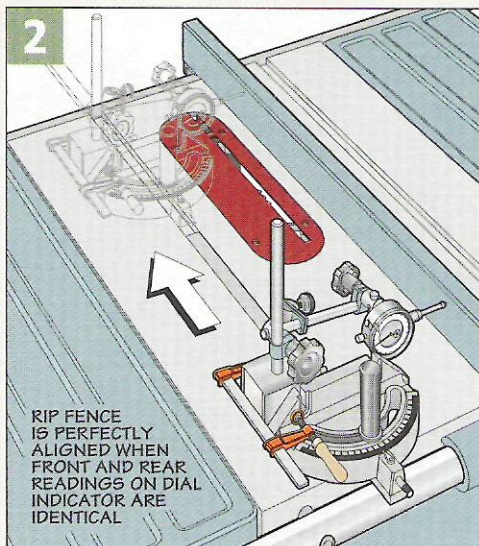

▲ **Rip Fence Alignment.** Aligning the rip fence is just a matter of checking for any variation between the front and rear of the fence.

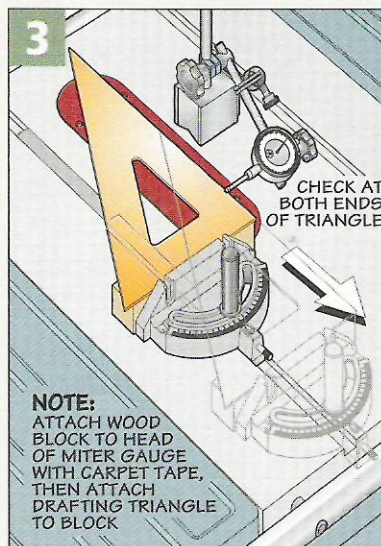

▲ **Miter Gauge.** A drafting triangle and dial indicator make quick work of squaring the head of a miter gauge.



5 GREAT USES

Okay, so a dial indicator makes it easy to see really small measurements. What good is this for woodworking? Listed below are five ways I make use of a dial indicator in my shop.

**1. Saw Blade Alignment** – One of the first things I checked was the alignment of the miter slot to the saw blade. To avoid burned edges and rough crosscuts, it's important that the miter slot and saw blade be perfectly parallel to each other.

You can do this by clamping the magnetic base to your miter gauge (the magnet won't work on most miter gauges) and then placing the tip of the dial indicator against the body of the raised saw blade (Figure 1).

After zeroing out the indicator, slide the miter gauge to the back of the saw blade and check to see if the reading stays the same. It's a good idea to repeat this check after turning the saw blade to a different position.

**2. Rip Fence Alignment** – You can also get rough cuts when the rip fence isn't aligned with the saw blade. In Figure 2 you can see how to use the same setup to check the alignment of the rip fence.

What you're looking for here is that the measurements at the front and back of the rip fence match.

Note: I actually prefer that the back of the fence is a couple thousandths further *away* from the saw blade than the front. This practically eliminates any chance of burned edges.

**3. Square the Miter Gauge** – Finally, to complete this quick table saw tune-up, the dial indicator can be used to square up the miter gauge.

Figure 3 shows you how to use a drafting triangle to do this. You can even use this procedure for setting the head of the miter gauge at any angle — provided you have a triangle that matches.

**4. Drill Press Table Alignment** – Next, I took the dial indicator over to the drill press. It's a great way to make sure the table is perpendicular to the chuck.

You can see in Figure 4 that the *vertical rod* from the magnetic base is installed in the chuck of the drill press. Now rotate the chuck by turning the belt at the top of the drill press (rotating the chuck itself can induce errors in the readings).

The table is perpendicular to the chuck when the reading on the dial indicator is the same regardless of where it's positioned on the table.

**5. Jointer Knives** – One last thing a dial indicator comes in handy for is setting jointer knives (Figure 5). Simply start with the magnet in the

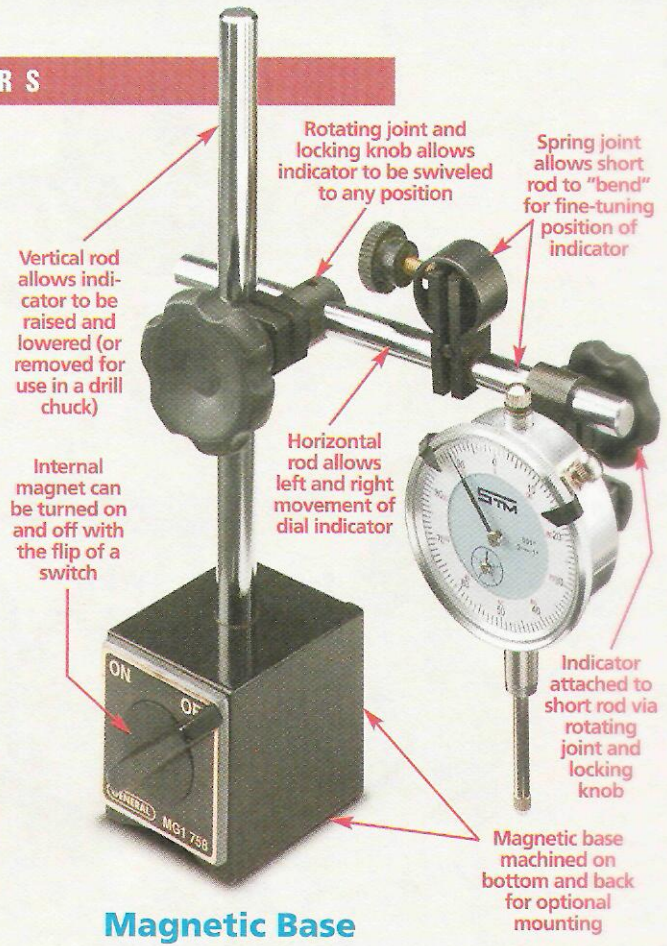

Magnetic Base

base turned off, and the base *and* contact point resting on the outfeed table. Then adjust the indicator to read zero.

With the knife at top dead center, reposition the base and indicator so the contact point is resting on the edge of the knife. The knife is set correctly when the indicator reads "zero" at any point along the edge.

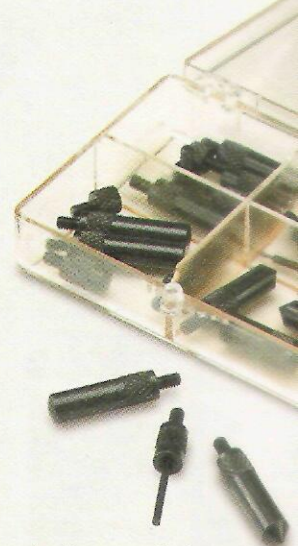
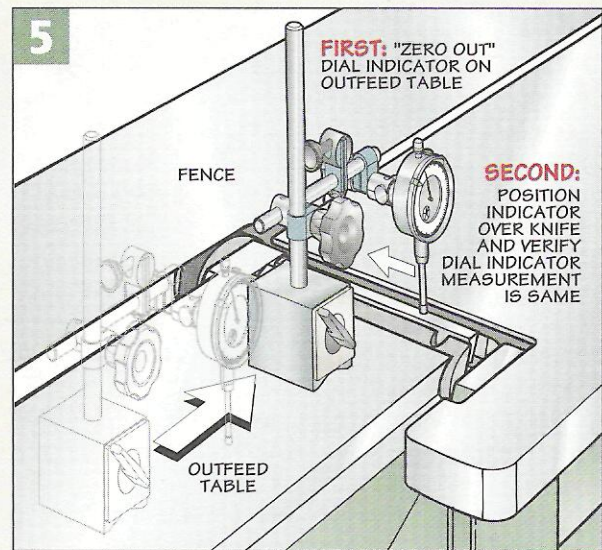
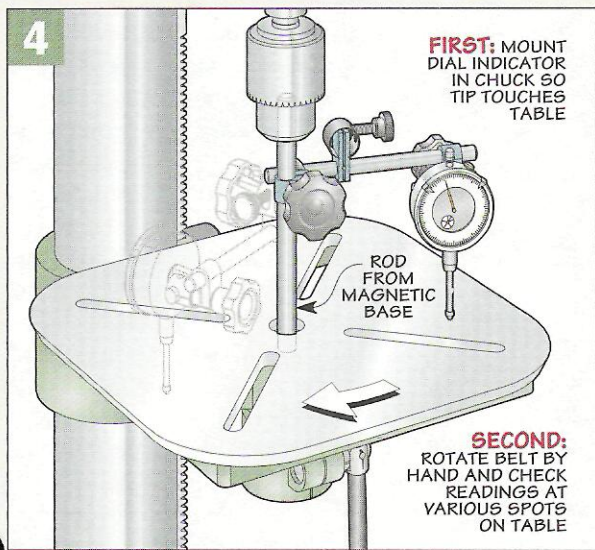

▲ **Contact Points.** A set of contact points with different shapes and lengths ensures you'll have just the right tip for your dial indicator.

**Drill Press Table.** To square a drill press table to the chuck, tighten the vertical rod from the magnetic base in the chuck and then rotate the indicator by hand.

**Setting Jointer Knives.** A jointer knife is set perfectly when the height matches the reading of a dial indicator that's been "zeroed out" on the outfeed table.

# Tool Chest

*It's hard to believe that you can improve on a great tool like the 690 router. But Porter-Cable has managed to do just that.*



## Porter-Cable 690 Router

**I**n today's world, it's not uncommon for tool manufacturers to redesign their power tools every couple of years. So when you come across a tool that has remained virtually unchanged for over a quarter of a century, you know that it's got to be good. And that's exactly the case with Porter-Cable's 690 router.

The 690 has been around since 1973. In "tool years" this is an eternity. And yet, it's still one of the best-selling routers on the market. That's because the 690 has proven itself to be a reliable, no-nonsense tool. It's kind of like the Model T of routers.

The 690 also happens to be one of *my* all-time favorite tools — for a number of reasons. The motor can be quickly removed from the base to facilitate bit changes. The collet can accommodate both 1/4" and 1/2" shank bits and has an auto-release feature so the bits won't get stuck.

And to top it all off, the 690 has a great balance and feel.

**New Design** — I've always been a believer in the expression "If it isn't broken, don't fix it." So I was a little concerned when I first heard that Porter-Cable was coming out with a "new" version of the 690 router. But when I finally saw the new router, I realized that I was worried about nothing. Fortunately, the folks at Porter-Cable realized they had a good design and just made a few subtle changes. And these changes actually help to make a great tool even better.

**Improvements** — As much as I liked the old 690 router, I have to admit that there were a few little annoyances with the original design. For one thing, the wing nut that locks down the height of the motor can be difficult and downright painful to turn. Porter-Cable took care of this by replacing the wing nut with a lever release that makes clamping and unclamping the base to the motor almost effortless (see photo A at left).

Another problem I had with the old design was a little more serious. If you were using the 690 in a router table, there was nothing to prevent the motor from falling out of the base if you lowered the bit too far. And if you forgot to tighten the wing nut to lock the height of the bit, the vibrations from the router could actually cause the motor to fall out of the base while you were using it.

Porter-Cable solved this by milling a couple of notches in the base of the router. So now if you lower the motor housing too much, the notches will engage a couple of pins in the side of the motor, preventing it from turning any further and dropping out of the housing. To override this feature, all you have to

do is push up on the motor while backing it out of the base.

Another change to the router that I noticed right away was the switch. The old 690 had a toggle switch. This new model has a rocker-type switch with a rubber boot to seal out dust (see photo B at left).

**Motor** — As nice as all these little changes are, the major difference between the new model and the old one is the motor. The motor on the new version has been beefed up from 10 to 11 amps, which translates to a 1 3/4 horsepower rating.

Now this may not sound like a huge jump in power, but it was necessary in order to give the new model a feature that wasn't previously available — variable speed. With the variable-speed model (690LRVS) you can control the speed of the router with the turn of a dial (see photo C at left). This is a nice feature to have, especially if you use a lot of large-diameter bits.

Along with the variable-speed option, the new motor has a soft-start feature. When you turn the router on, it gradually revs up to full speed — so the router doesn't feel like it wants to jump out of your hands.

If you don't have a need for a variable-speed router, you're still in luck. Porter-Cable also offers the new router in a traditional, single-speed version, just like the old one.

**Price** — With all the improvements on the new version, I was expecting a big jump in the price. Fortunately, this isn't the case. The single-speed router (model 690LR) sells for around \$140 (about the same price as the old 690). And you can get the variable-speed model (690LRVS) for about \$15 more.

When my old 690 finally gives up the ghost, I'll have no hesitation about buying one of these two new versions. But who knows — that could be years down the road. 

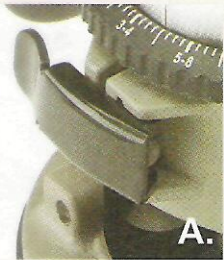

A.

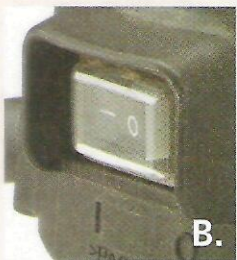

B.



C.

# Sources

## Dial Indicator

■ Dial indicators are an inexpensive way to bring machine-shop accuracy into your woodshop. For less than \$20 you can measure to within a thousandth of an inch (0.001").

And to make your dial indicator work even better, you can add a magnetic base and a set of replaceable contact points. The margin at right details sources for both dial indicators and accessories.



## Shop Cart

■ There's not much hardware that goes into the shop cart. And you should be able to find most of it at a hardware store or home center. Or you can order similar hardware from the sources listed at right.

**Casters** – We used a pair of non-locking, swivel casters on the cart and a pair of locking swivel casters, as shown in the photo. What's unique about them is that the



locking mechanism prevents them from both rolling and swivelling.

**Slides** – To support a fully loaded drawer and reach items in the back, we used full-extension drawer slides (20" long).

## Horizontal Mortising Machine

■ The horizontal mortising machine requires quite a bit of hardware, some of which you may not find at your local hardware store or home center.

To save you the hassle of tracking everything down, *ShopNotes Project Supplies* has put together a kit that contains all the hardware you'll need for building the project. All

you need to supply are the router, plywood, and the router table insert.

To order the kit, see the box below.

### Horizontal Mortising Machine Kit

**6868-100.....\$104.95**

If you choose not to get the kit, we've listed several sources for some of the hard-to-find hardware in the margin at right.

**Router Table Insert** – The router table insert we used was a 9<sup>1</sup>/<sub>4</sub>" x 11<sup>3</sup>/<sub>4</sub>" - 3/8"-thick phenolic plate from Woodhaven (#147).

**Aluminum** – The aluminum bar stock is available at most home centers. But, the channel may be harder to find. We ordered ours from an Ace Hardware store. You can use a different thickness of

channel so long as it fits over 3/4" plywood.

**Springs** – To find the right springs, we looked at both the diameter of the wire (.063") as well as the length of the spring (2<sup>5</sup>/<sub>8</sub>"). What you're looking for is a spring that's tight enough to hold the parts together but loose enough to be installed and adjusted easily. 

*Similar project supplies may be ordered from the following companies:*

**Rockler**  
800-279-4441  
rockler.com

*Casters, Drawer Slides, Knobs, Router Bit Guard, Router Table Insert, T-Track, UHMW*

**Reid Tool**  
800-253-0421  
reidtool.com

*Aluminum, Casters, Contact Points, Dial Indicator, Drawer Slides, Knobs, Springs*

**Lee Valley**  
800-871-8158  
leevalley.com

*Casters, Dial Indicator, Drawer Slides, Phenolic, T-Track, UHMW*

**Woodsmith Store**  
800-835-5084

*Dial Indicator, Drawer Slides, Knobs, Hold-Downs, T-Track*

**McMaster-Carr**  
630-833-0300  
mcmaster.com

*Casters, Contact Points, Dial Indicator, Drawer Slides, Phenolic, Springs*

**Woodcraft**  
800-225-1153  
woodcraft.com

*Drawer Slides, Knobs, Router Table Insert, T-Track, UHMW*

**Woodhaven**  
800-344-6657  
woodhaven.com

*Knobs, Phenolic, Router Bit Guard, Router Table Insert*

## SHOPNOTES PROJECT SUPPLIES

To order back issues or a hardware kit from *ShopNotes Project Supplies*, please use our toll-free order line, see below. It's open Monday through Friday, from 8 AM to 5 PM Central Time. Before calling, please have your VISA, MasterCard, Discover, or American Express card ready.

If you would prefer to mail in an order, please call the toll-free phone number below for more information concerning shipping charges as well as any applicable sales tax.

**1-800-347-5105**

## ShopNotes *on the web*

- "Online Extras" - Plans, Patterns, & More
- Over 100 Woodworking Tips Online
- Visit Our Readers' Project Photo Gallery
- Project Plans You Can Download
- Catalog of Project Kits, Tools, Jigs, & Plans
- Forums for Woodworking, Tools, & Classifieds
- Links to Other Woodworking Sites
- Order *ShopNotes* & *Woodsmith* Back Issues

**www.shopnotes.com**

### Online Customer Service

Click on Subscriber Services at  
**www.shopnotes.com**

- Access your account status
- Change your mailing or email address
- Pay your bill
- Renew your subscription
- Tell us if you've missed an issue
- Find out if your payment has been received

# Scenes from the Shop

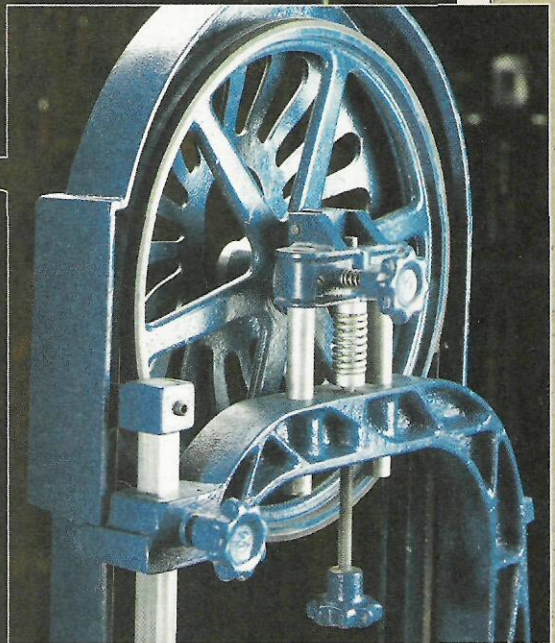
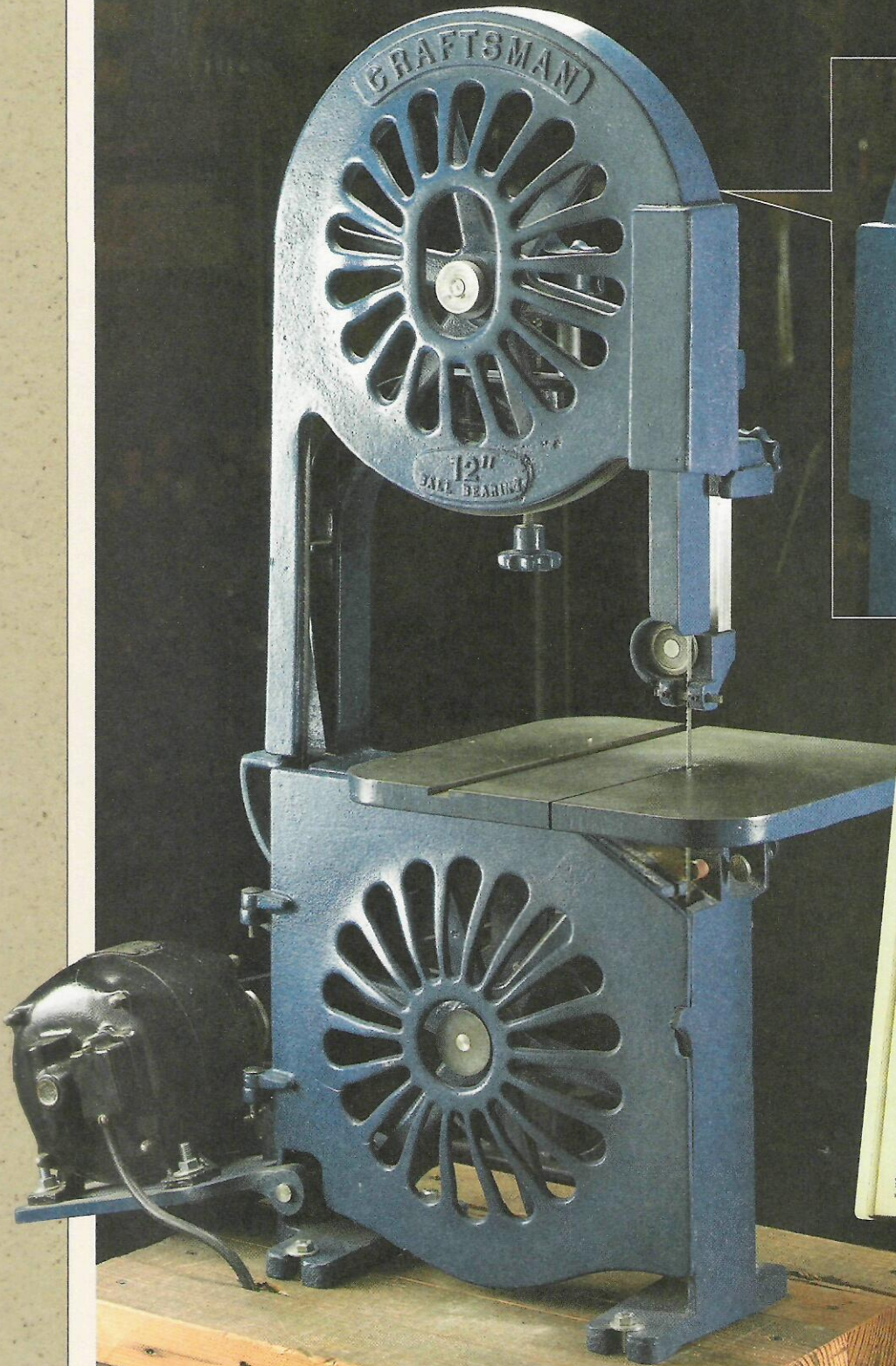

Balanced, Smooth Running, Fully Guarded...

## CRAFTSMAN 12-INCH BAND SAW

**\$29.50**  
CASH  
Without Motor  
On Easy Payments  
**\$6.00** Down  
**\$5.00** Monthly

**FEATURES**

- 3 heavy cast-iron casters for cast
- Both wheels adjustable
- Choke frame bearings
- Concentrated idler guide
- Safety guard
- Capable of cutting lumber

**PLAHER DRIVES**  
High Speed Steel

**SPECIFICATIONS**

Power: All cast-iron casters for cast...  
Capacity: 12 in. x 1 1/2 in. x 1/2 in. (actual)  
Weight: 122 lbs. (actual net)

**Dynamically Balanced—Fully Adjustable**

We put in an extra expert to design the best saw ever possible to build. They were the job done with thousands of every best improved upon them in a new and better, dynamically balanced and adjustable when used.

**Easy to Operate**

The CRAFTSMAN is easy to operate. The frame is cast in one piece at right angles and level back. The support is cast in one piece or angle. Two more make it easy to move the table to the left or right. The saw blade above the table is held in place by the rubber stop and a heavy spring. The rubber stop is cast in one piece and is held in place by a heavy spring. The rubber stop is cast in one piece and is held in place by a heavy spring.

**Compare It With Others**

With the CRAFTSMAN 12 inch band saw you can cut any size of wood. The heavy frame is cast in one piece and is level back. The support is cast in one piece or angle. Two more make it easy to move the table to the left or right. The saw blade above the table is held in place by the rubber stop and a heavy spring. The rubber stop is cast in one piece and is held in place by a heavy spring.

**FEATURES**

- 3 high speed steel blades, 4 1/2 in. long
- Adjustable table and head cast in one piece
- Both wheels adjustable
- Ball bearing loaded in oil for life of the machine
- Chrome vanadium steel shaft
- Patented roller guides holding angle of fence
- Improved aluminum safety guard

SEARS, ROEBUCK AND CO.

▲ After seventy years of service, this vintage, 12-inch Craftsman band saw is still in use today. With its heavy, cast iron wheels (see inset photo), it can slice through

stock up to 5" thick, even though it's powered by just a small, 1/4 hp electric motor. In 1933, Sears offered this saw for \$29.50 (not including the motor).

# Horizontal Mortising Machine

## Materials

### Tapered Bed

A Base (1)	20 x 24 - <sup>3</sup> / <sub>4</sub> Plywood
B Sides (4)	5 x 16 - <sup>3</sup> / <sub>4</sub> Plywood
C Adjustment Blocks (2)	2 <sup>3</sup> / <sub>4</sub> x 6 <sup>1</sup> / <sub>2</sub> - <sup>3</sup> / <sub>4</sub> Plywood
D Top (1)	9 <sup>1</sup> / <sub>2</sub> x 16 - <sup>3</sup> / <sub>4</sub> Plywood

### Sliding Table

E Table (1)	9 <sup>1</sup> / <sub>2</sub> x 23 <sup>3</sup> / <sub>4</sub> - <sup>3</sup> / <sub>4</sub> Plywood
F Handles (2)	1 x 9 <sup>1</sup> / <sub>2</sub> - <sup>3</sup> / <sub>4</sub> Plywood
G Cleat (1)	3 x 12 - <sup>3</sup> / <sub>4</sub> Plywood
H Spacer (1)	1 x 7 <sup>1</sup> / <sub>2</sub> - <sup>3</sup> / <sub>4</sub> Plywood

### Carriage

I Front (1)	12 <sup>1</sup> / <sub>4</sub> x 12 - <sup>3</sup> / <sub>4</sub> Plywood
J Back (1)	12 <sup>1</sup> / <sub>4</sub> x 4 - <sup>3</sup> / <sub>4</sub> Plywood
K Sides (2)	12 x 12 - <sup>3</sup> / <sub>4</sub> Plywood
L Bottom (1)	11 <sup>3</sup> / <sub>4</sub> x 10 <sup>1</sup> / <sub>2</sub> - <sup>3</sup> / <sub>4</sub> Plywood
M Clamp Blocks (2)	2 <sup>1</sup> / <sub>2</sub> x 11 <sup>1</sup> / <sub>4</sub> - <sup>3</sup> / <sub>4</sub> Plywood
N Lever Arm (1)	1 <sup>1</sup> / <sub>2</sub> x 17 - 1 <sup>1</sup> / <sub>2</sub> Plywood
O Lever Arm Block (1)	2 x 4 - 1 <sup>1</sup> / <sub>2</sub> Plywood

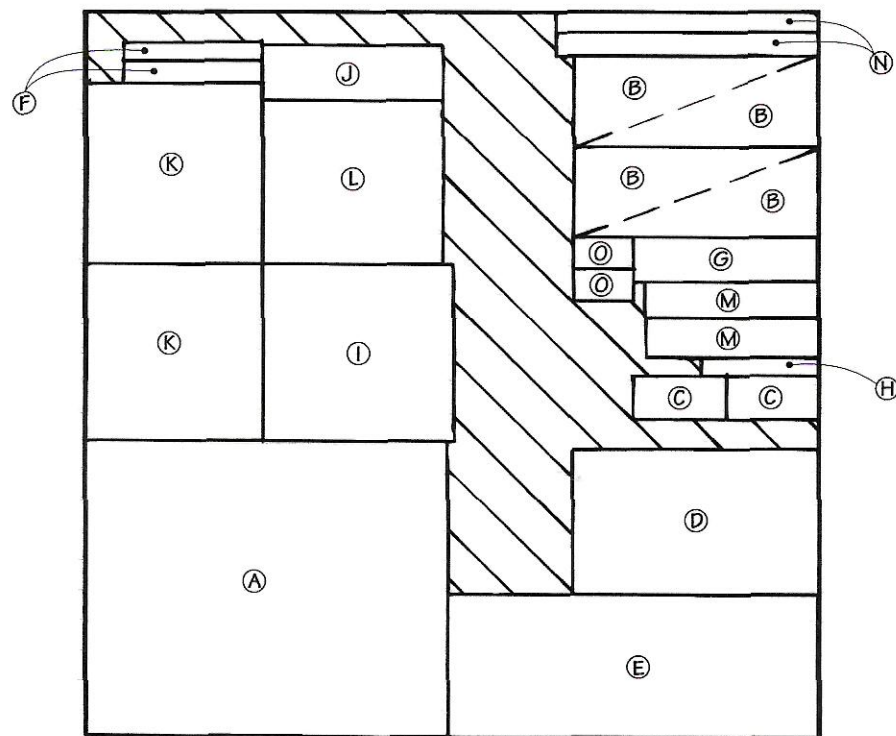

48" x 48" - <sup>3</sup>/<sub>4</sub>" PLYWOOD

# Roll-Around Shop Cart

## Materials

### Cart

A Stiles (4)	$1\frac{1}{2} \times 3\frac{1}{2} - 23$
B Center/Bottom Rails (4)	$1\frac{1}{2} \times 3\frac{1}{2} - 22$
C Upper Rails (2)	$1\frac{1}{2} \times 1\frac{1}{2} - 22$
D Side Panels (2)	$7\frac{1}{2} \times 22 - \frac{3}{4}$ MDF
E Filler Strips (4)	$1\frac{1}{2} \times \frac{3}{4} - B$
F Shelf/Bottom Panel (2)	$19 \times 26\frac{1}{2} - \frac{3}{4}$ MDF
G Edging	$\frac{3}{4} \times \frac{3}{4} - 25$ Ln. Ft.
H Divider (1)	$12\frac{3}{4} \times 19\frac{3}{4} - \frac{3}{4}$ MDF
I Top (1)	$22 \times 30\frac{1}{2} - \frac{3}{4}$ MDF
J Cleats (3)	$1\frac{1}{2} \times 1\frac{1}{2} - 19$
K Caster Plates (2)	$\frac{3}{4} \times 3\frac{1}{2} - 22$

### Drawers

L Small Drawer Front/Back (2)	$\frac{1}{2} \times 3\frac{1}{2} - 17\frac{1}{2}$
M Small Drawer Sides (2)	$\frac{1}{2} \times 3\frac{1}{2} - 20$
N Large Drawer Front/Back (2)	$\frac{1}{2} \times 7\frac{1}{2} - 17\frac{1}{2}$
O Large Drawer Sides (2)	$\frac{1}{2} \times 7\frac{1}{2} - 20$
P Drawer Bottoms (2)	$17\frac{1}{2} \times 19\frac{1}{2} - \frac{1}{4}$ Ply.
Q Spacers (2)	$\frac{3}{8} \times 1\frac{1}{4} - 17\frac{1}{8}$
R Small Drawer False Front (1)	$\frac{3}{4} \times 4\frac{3}{16} - 19\frac{1}{2}$
S Large Drawer False Front (1)	$\frac{3}{4} \times 8\frac{3}{16} - 19\frac{1}{2}$
T Cubby Front (1)	$\frac{3}{4} \times 3\frac{1}{8} - 19\frac{3}{4}$

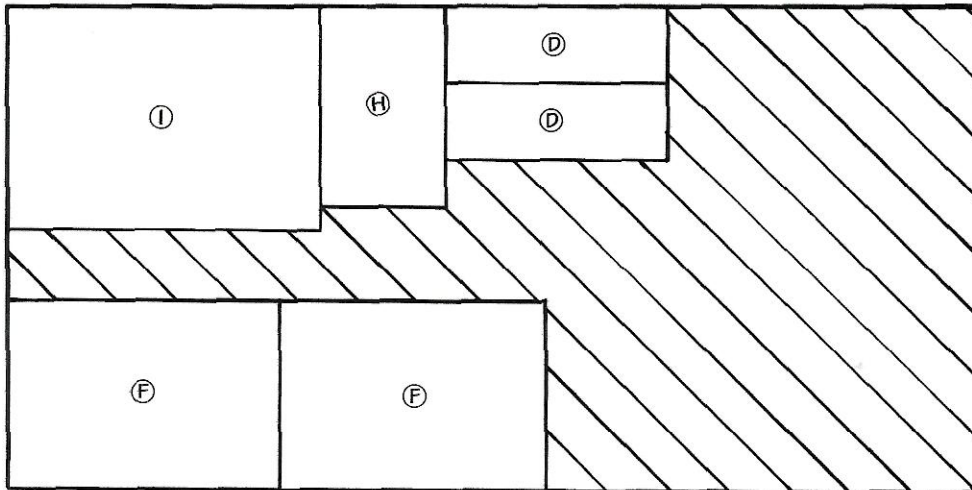

49" x 97" -  $\frac{3}{4}$ " MDF

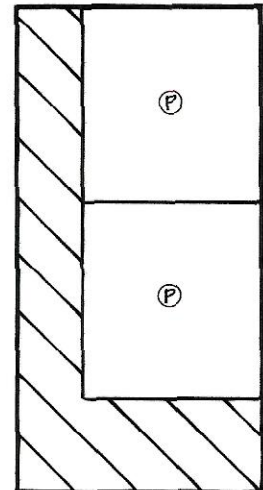

24" x 48" -  $\frac{1}{4}$ " PLYWOOD

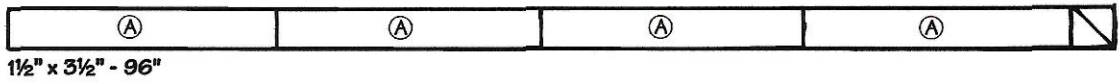

1 1/2" x 3 1/2" - 96"

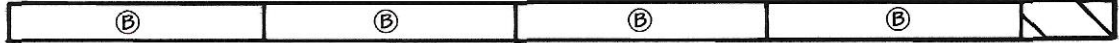

1 1/2" x 3 1/2" - 96"

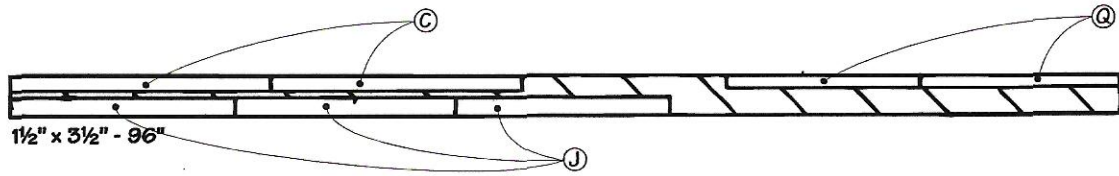

1 1/2" x 3 1/2" - 96"

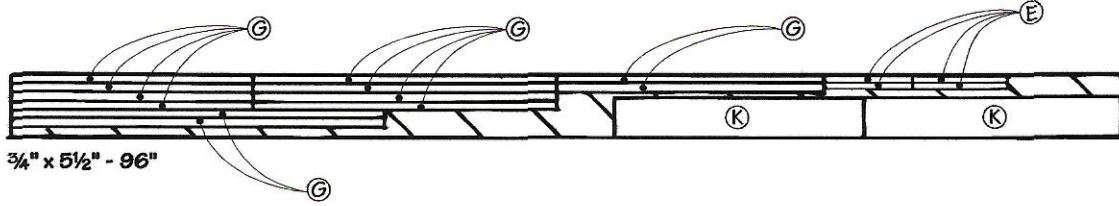

3/4" x 5 1/2" - 96"



3/4" x 5 1/2" - 96"

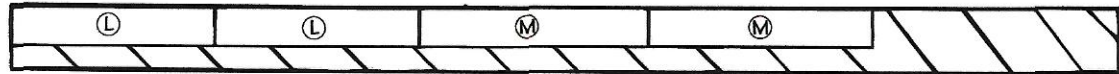

1/2" x 5 1/2" - 96"

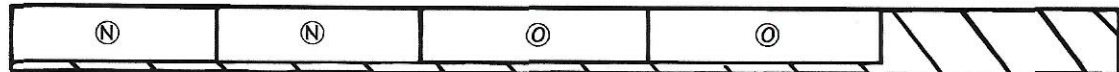

1/2" x 5 1/2" - 96" (2 Boards)