

**BUILD A**  
Benchtop Vise

**12**

**PROJECTS FOR YOUR SHOP**

# ShopNotes®

Vol. 12

[www.ShopNotes.com](http://www.ShopNotes.com)

Issue 71

## 5 PROJECTS You Can Build From ONE SHEET OF PLYWOOD



**STOW-AWAY ROUTER  
TABLE HAS IT ALL:**

- Quick-Clamp Router
- Full-Feature Fence
- 1 Minute Setup





# ShopNotes®

Issue 71

September 2003

**PUBLISHER** Donald B. Peschke

**EDITOR** Terry J. Strohman

**ASSOCIATE EDITORS** Bryan Nelson

Vincent Ancona

**CONTRIBUTING EDITOR** Phil Huber

**ART DIRECTOR** Cary Christensen

**SR. GRAPHIC DESIGNER** Kurt Schultz

**SENIOR ILLUSTRATORS** Roger Reiland  
Mark Higdon

### CREATIVE RESOURCES

*Creative Director:* Ted Kralicek • *Sr. Project Designers:* Ken Munkel, Kent Welsh, Ryan Mimick, Chris Fitch • *Shop Craftsmen:* Steve Curtis, Steve Johnson • *Sr. Photographer:* Crayola England

### SPECIAL PUBLICATIONS

*Corp. V.P.:* Douglas L. Hicks • *Art Director:* Douglas A. Flint • *Sr. Graphic Designer:* Chris Glowacki • *Graphic Designer:* Jonathan Eike • *Sr. Editor:* Craig Ruegsegger • *Assoc. Editor:* Joel A. Hess

### CIRCULATION

*Circ. Oper. Director:* Sandy Baum • *Circ. Marketing Dir.:* Wayde J. Klingbeil • *Strategic Business Analysts:* Kris Schlemmer, Paula M. DeMatteis • *Circ. Marketing Analyst:* Patrick Walsh • *Renewal Mgr.:* Paige Rogers • *Circ. Fulfillment Mgr.:* Stephanie Forinash • *Sr. Graphic Designers:* Mark Hayes, Jr., Robin Friend

### CORPORATE SERVICES

*V.P. of Finance:* Mary R. Scheve • *Controller:* Robin K. Hutchinson • *Sr. Acct.:* Laura J. Thomas • *Accts. Payable:* Mary J. Schultz • *Accts. Receivable:* Margo Petrus • *Prod. Dir.:* George Chmielarz • *Electronic Pub. Dir.:* Douglas M. Lidster • *System Admin.:* Cris Schwanebeck • *P.C. Maint. Tech.:* Robert D. Cook • *Pre-Press Image Specs.:* Troy Clark, Minnette Johnson • *Assoc. Style Dir.:* Rebecca Cunningham • *New Media Mgr.:* Gordon C. Gaipe • *Multimedia Art Dir.:* Eugene Pedersen • *Web Server Admin.:* Carol Schoeppler • *Web Content Mgr.:* David Briggs • *Multi-media Designer:* Kara Blessing • *Research Coordinator:* Nicholas A. Jaeger • *Prof. Dev. Dir.:* Michal Sigel • *H. R. Asst.:* Kirsten Koele • *Office Mgr.:* Natalie Lonsdale • *Facilities Mgr.:* Kurt Johnson • *Admin. Asst./Recept.:* Jeanne Johnson • *Mail Room Clerk:* Lou Webber

### WOODSMITH STORE

*Operations Director:* Bob Baker • *Customer Service Mgr.:* Jennie Enos • *Warehouse Supr.:* Nancy Johnson • *Buyer:* Linda Jones • *Admin. Asst.:* Nancy Downey • *Sr. Cust. Serv. Reps.:* Tammy Truckenbrod, Anna Cox, Deborah Rich, April Revell • *Cust. Serv. Reps.:* Valerie Jo Riley, Kim Harlan, Cheryl Jordan • *Warehouse:* Sylvia Carey, Larry Morrison • *Store Manager:* Dave Larson • *Merchandise Marketing Mgr.:* John Siberell • *Paint Dept. Mgr.:* James Hockins • *Asst. Mgr.:* Tim Thelen • *Store Sales Staff:* Gregory Kauzlarich, Mark Johnson, John Warren, Dave Fremming, Stephen Duncan, Brian Simmons, Mike McCavley • *Office Mgr.:* Vicki Edwards

ShopNotes® (ISSN 1062-9696) is published bimonthly (Jan., March, May, July, Sept., Nov.) by August Home Publishing, 2200 Grand, Des Moines, IA 50312.

ShopNotes® is a registered trademark of August Home Publishing © Copyright 2003 by August Home Publishing. All rights reserved. Subscriptions: Single copy: \$4.95. One year subscription (6 issues), \$27.95. Canada/International add \$10 per year, U.S. funds. Periodicals Postage Paid at Des Moines, IA and at additional mailing offices.

Postmaster: Send change of address to ShopNotes, P.O. Box 37103, Boone, IA 50037-2103.

Subscription Questions? Write to: ShopNotes Customer Service, P.O. Box 842, Des Moines, IA 50304-9961. Or call 1-800-333-5854, 8:00 am to 5:00 pm, Central Time, weekdays. FAX 515-283-0447  
Email: ShopNotes@shopnotes.com  
Internet: http://www.shopnotes.com

PRINTED IN U.S.A.

## EDITOR'S NOTE

# Cutoffs

I enjoy a challenge. And, as you know, woodworking is certainly filled with them. They pop up when we're working on a project and usually deal with some aspect of joinery, assembly, or finishing.

But in this issue we *started* with a different kind of challenge: what can you build from just one sheet of plywood? It also had to be practical and stand up to everyday shop use.

If you take a look at the front cover you'll see we ended up with not just one, but five great shop projects. There's a pair of folding sawhorses, an easy-to-build workbench, a roll-around cutoff storage bin, some wall cabinets and a couple of tool totes. It's hard to believe you can get a shopful of projects from just five sheets of plywood. I guess sometimes you need a challenge just to see what's possible.

**New Store.** Speaking of challenges, quite a few of the people here at August Home Publishing have been working on another big project. This summer the Woodsmith Store moved

to a new location here in Des Moines, Iowa. This new store has over 20,000 square feet of space, packed with tools, lumber, hardware, and supplies. Everything a woodworker could want, including three full-size display shops.

If you're in the area, be sure and stop by for a visit. For more information and directions on how to get there, visit the website:

[www.WoodsmithStore.com](http://www.WoodsmithStore.com)

## HELP WANTED

We're looking for a couple of experienced people to join us here at August Home Publishing as an editor and a graphic designer/illustrator. If you're enthusiastic about woodworking and home improvement and enjoy working as part of a team, then we would like to hear from you. Send a cover letter and a resume highlighting your experience to: Human Resources, 2200 Grand Ave., Des Moines, IA 50312. Or you can send an email to: [hr@augusthome.com](mailto:hr@augusthome.com).

Terry

## Be included, as a part of the Woodworking Shop Tours

On the Web

Visit other ShopNotes subscribers' workshops and see photos of the shop projects they've built. It's all online at Woodworking Shop Tours on the ShopNotes web site:

[www.ShopNotes.com](http://www.ShopNotes.com)

We want you to be part of our shop tours! To submit photos of your favorite ShopNotes projects or views of your shop, just follow the instructions you'll find on our web site.





# Contents

## Features

### Stow-Away Router Table \_\_\_\_\_ 6

*This space-saving shop essential has features some bigger router tables only dream about. It stows away when you don't need it and mounts to your workbench in less than a minute.*

### Super-Strong Box Joints \_\_\_\_\_ 12

*Cutting small box joints is one thing, but cutting them with fingers 2" long requires a little different technique. We show you how to do it with our step-by-step instructions.*

### Shop-Made Benchtop Vise \_\_\_\_\_ 14



*Round stock, carvings, odd shapes — this benchtop vise can handle it all. We've designed it with a variety of jaw faces and updated a classic design to meet today's needs.*

### Working with Plywood \_\_\_\_\_ 22

*Do you dread the thought of moving, storing, or cutting a large, heavy sheet of plywood? Learn a few of the techniques we use to make working with plywood hassle-free.*

### 5 Plywood Shop Projects \_\_\_\_\_ 26

*It won't take a lot of time, effort, or material to outfit your shop with storage, worksurfaces, and several handy accessories. Each project can be built from a single sheet of plywood.*

## Departments

### Readers' Tips \_\_\_\_\_ 4

*Shop-tested tips to solve common woodworking problems.*

### Tool Chest \_\_\_\_\_ 32

*Block planes have been around for a long time. But we've found one that incorporates some new features and accessories that are sure to make it one of your favorite tools.*

### Shop Talk \_\_\_\_\_ 34

*Glue doesn't keep forever. Here's what you need to know to determine if it's "too old to hold" on your next project.*

### Sources \_\_\_\_\_ 35

*Mail-order sources and supplies to help you complete the projects featured in this issue.*

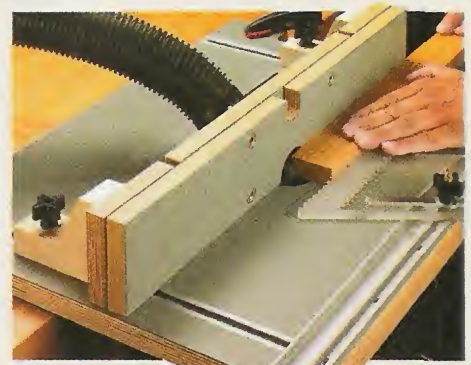

Router Table

page 6



Box Joints

page 12



Benchtop Vise

page 14



5 Plywood Projects

page 26



# Readers' Tips

## Wing Nut Jig

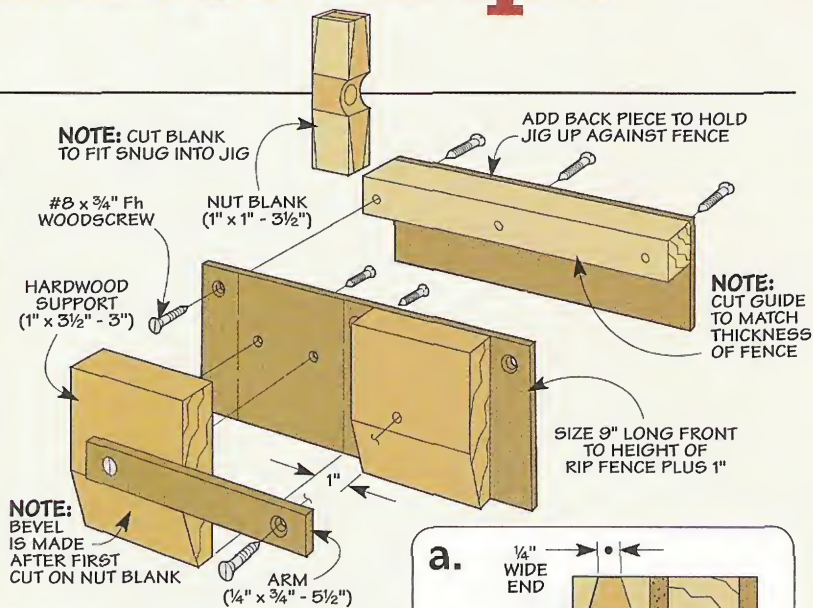

■ To save money, I make my own wing nuts for jigs and other shop projects. One of my favorite designs is from *ShopNotes* No. 26. But after making a few by hand, I came up with a jig to safely cut them on the table saw, as in the photo above.

The jig rides on the rip fence and holds the blanks in place while they're being cut. It's designed to cut wing nuts from 1"-thick blanks, as you can see in the photo at left.

It's made by gluing and screwing two hardwood supports to a 1/4" hardboard front, as in the drawing. (Shop Note: Make sure the screws are located above where the saw blade will pass.) A hardboard arm is screwed across the front to help hold the wing nut blank in place. Finally a guide and back piece are attached to the front to run on the rip fence, as shown in detail 'a.'

To make a wing nut, start by drilling a circular opening at the top

and a counterbored hole through the center for a T-nut and bolt. Then slip the blank in the jig to cut to size.

Bob Satterlee  
Madisonville, Louisiana



## Wall-Mounted Rags

■ There never seem to be enough rags in my shop to clean up spills, apply finish, or wipe off my hands. While old T-shirts will do fine, I find it easier to just buy a box of rags. The problem is the box of rags is so light. When I try to pull one rag out, I end up picking up the whole box. And if my hands are dirty, I end up getting the box dirty as well trying to get the rag out.

My solution is to mount the box to a pegboard tool rack, as in the photo. I made two hardwood cleats to hold the box. They are connected to threaded rod at the ends. Each threaded rod is then screwed into a threaded insert mounted in the pegboard, as in the inset photo. Now the rag box is secure and I can pull out one at a time.

Brent Garbuschewski  
Howell, Michigan





## Quick Tips



▲ To keep router bits from bottoming out in the collet, **Serge Duclos** of Delson, Quebec, Canada puts a dab of silicone on the end.



▲ **Kevin Boudreau** of Mahomet, IL installed aluminum flashing to prevent the router plate set screws from digging into the support cleats.



▲ **Donald Slabe** of Swissvale, PA keeps his cordless drill within easy reach by hanging it from a hook screwed to the ceiling of his shop.

## Routing Parallel Miter Gauge Slots

■ The box joint jig from *ShopNotes* No. 62 makes it easy to make box joints on the table saw. But I adapted the design so that it works on my router table, as shown in the photo. The benefit of this is that since router bits are a consistent diameter, it's even easier to set up.

However, the jig has two runners to fit both miter gauge slots on the table saw. So I needed to rout a second miter gauge slot on my router table. And for the jig to work correctly, the new slot has to be perfectly parallel to the original slot.

To do this, I made a simple jig for a hand-held router, as illustrated in the drawing below. It's made from a piece of  $\frac{3}{4}$ " plywood. I attached the



router to one end using the existing baseplate mounting hole screws. A hardwood runner that rides in the miter gauge slot gets screwed to the other end. This keeps the router run-

ning parallel to the slot. I installed a  $\frac{3}{4}$ "-dia. straight bit and then routed the groove in two passes.

*Joe Watson  
Richmond, Virginia*

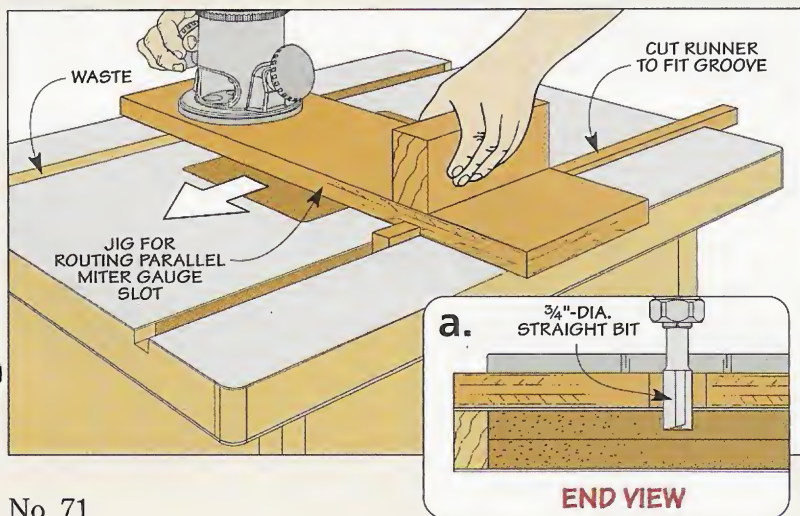

### Free Tips ON THE WEB

Get more wood-working tips free. Visit us on the Web at [ShopNotes.com](http://ShopNotes.com)

Sign up to receive a free shop tip by email every week.

### Send in Your Shop Tips

If you have a unique shop tip, we'd like to consider featuring it in one or more of our print or electronic publications.

We'll pay up to \$200 for a tip we publish. Just write down the tip and mail it to *ShopNotes*, Attn.: Readers' Tips, 2200 Grand Ave., Des Moines, IA 50312. Or FAX it to 515-282-6741, or send us an email at [shopnotes@shopnotes.com](mailto:shopnotes@shopnotes.com). Please include your name, address, and daytime phone number in case we have any questions.



# Stow-Away Router Table



*This project has all the capabilities of a full-size router table, yet stows away easily.*

**A** challenge in most shops is finding room for all your tools. The router table shown above solves the problem of always having a router table handy, yet it doesn't take up valuable shop space when it's not in use.

The compact size of this table makes it easy to store just about anywhere. But when you need to use it, the table can be pulled out and mounted easily to any workbench. If your bench has a face vise, clamping it in place is a snap, as in the photo above. Or you can simply mount it to the bench with clamps (left photo below).

To make set up even quicker, check out the center photo below to see how the router is held in the table. A set of quick-release toggle clamps allows you to install (or remove) the router in seconds. Unlike most router tables, you won't be wasting a lot of time getting your router in place or removing it once you're done.

Finally, the aluminum tracks along the front and sides of the table make it easy to quickly and accurately position the fence or a featherboard (lower right photo).

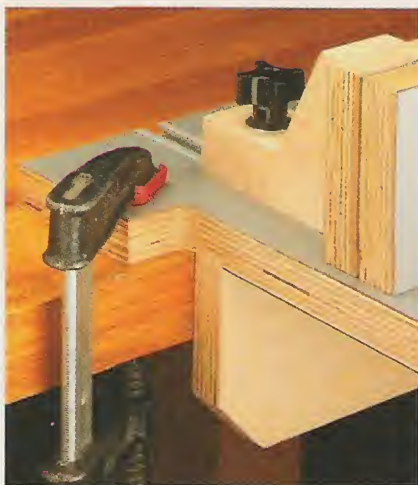

▲ **Alternative Mount.** You can also mount the router table using clamps on the tabs at the back of the table.



▲ **Toggle Clamps.** Quick and easy, toggle clamps make it a snap to remove (or install) the router in the table.



▲ **Accessories.** An aluminum track allows the use of a miter gauge or the featherboard shown above.



**EXPLODED VIEW**  
**OVERALL DIMENSIONS:**  
 24"W x 17½"D x 7⅞"H

REVERSIBLE  
 FENCE HAS  
 DIFFERENT SIZE  
 BIT OPENINGS

DUST HOOD  
 ALLOWS EASY  
 HOOK UP OF  
 SHOP VACUUM

FENCE SLIDES ON  
 T-TRACK FOR EASY  
 ADJUSTMENT

DUAL TRACK  
 ALLOWS USE OF  
 MITER GAUGE OR  
 FEATHERBOARD

GUARD  
 MOUNTS TO  
 FENCE WITH  
 STUDDED KNOB  
 AND WASHER

LAMINATED  
 TOP PROVIDES  
 LARGE SMOOTH  
 WORKSURFACE

TOGGLE CLAMPS  
 ALLOW QUICK AND  
 EASY REMOVAL  
 (OR INSTALLATION)  
 OF ROUTER

REAR SUPPORT  
 PROVIDES FACE  
 VISE MOUNTING  
 OPTION

SWITCHED  
 OUTLET

SIDE SUPPORT  
 PREVENTS TOP  
 FROM SAGGING

**Materials & Hardware**

A Table (1)	17½ x 24 - ¾ Ply.
B Front Lip (1)	1⅝ x 21½ - ¾ Ply.
C Rear Support (1)	3½ x 21½ - ¾ Ply.
D Side Support (1)	3½ x 11⅝ - ¾ Ply.
E Fence Faces (2)	3¼ x 21 - ¾ Ply.
F Fence Brackets (2)	1½ x 3 - 4

- (1) Dual Track
- (1) T-Track (32" long)
- (3) 213-U De-Sta-Co Toggle Clamps
- (8) ⅝-18 Brass Inserts
- (8) ⅝" Washers
- (2) ⅝" x 1" Studded Knobs
- (2) ⅝" x 1½" Studded Knobs
- (4) ⅝"-18 Through Knobs
- (4) ⅝" x 1¾" Flange Bolts
- (4) #8 x 1¼" Fh Woodscrews
- (2) #8 x 2" Fh Woodscrews
- (2) #8 x 2½" Fh Woodscrews
- (6) #6 x ⅝" Fh Woodscrews
- (8) #6 x ¾" Fh Woodscrews
- (14) #8 x ⅝" Ph Woodscrews
- (1) Dust Hood
- (1) Guard
- (1) Featherboard

Note: To order a complete hardware kit, turn to Sources on page 35.

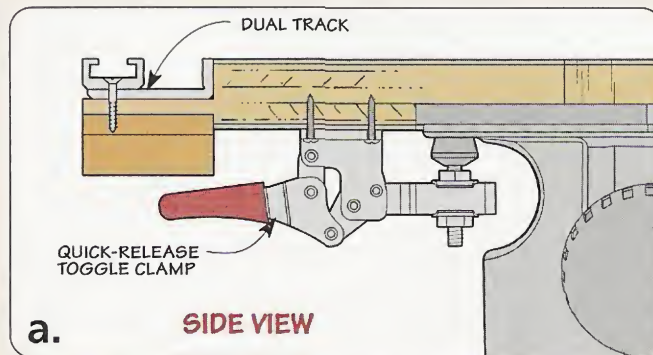

**a. SIDE VIEW**



# Table

A quick look at Figure 1 shows that the top of this router table is large enough to do serious routing. But what makes the table really versatile is the aluminum dual track and T-track installed in the top.

**T-Track** – I wanted to make it easy to secure the fence to the table and easy to adjust afterward. T-track is the answer. This is just an extruded aluminum channel that allows you to use a flange bolt and knob to attach a fence or accessories, like a feather-board. Likewise, dual track uses the same extruded channel. But it's paired with an L-shaped extrusion to create a groove for a miter gauge.

▲ **Aluminum Track.** Adding a dual track and T-track to the router table makes it easy to position the fence and accessories.

**Size the Table** – Before you can add either track, you'll need to make the table. The *table* (A) starts with a rectangular piece of 3/4" plywood. (I used Baltic birch.) Then to provide a smooth worksurface and help stiffen the plywood, I applied plastic laminate to both sides.

It's best to apply an oversized piece of plastic laminate to each side of the table and then trim them flush. Once that's complete, you can turn

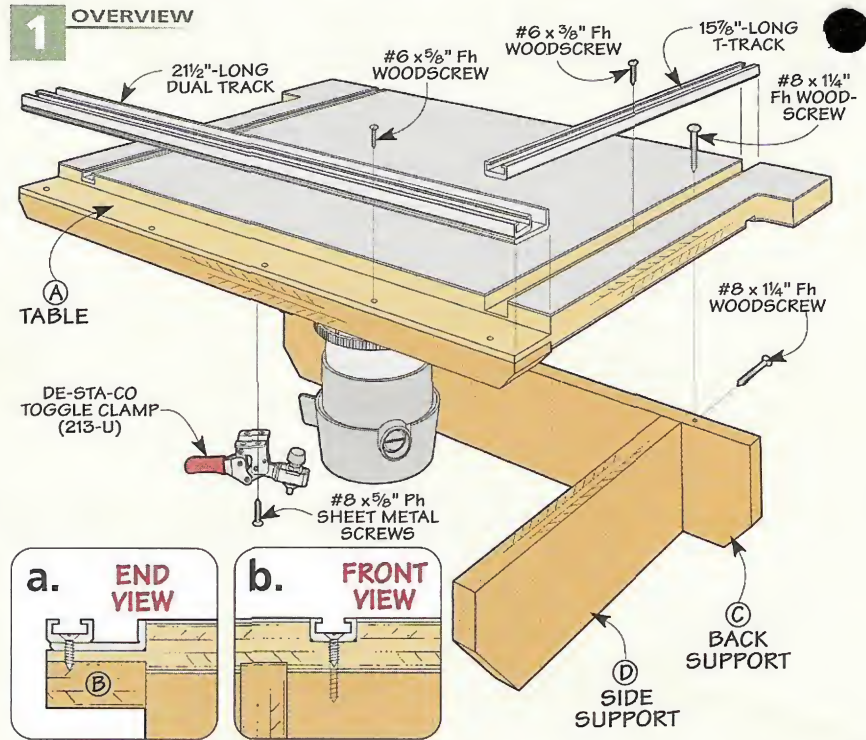

your attention to the work illustrated in Figures 2 and 3.

**Mounting the Router** – To provide a quick means of mounting the router, yet make it easy to remove when I needed to use it for a hand-held operation, I used toggle clamps.

But the clamps won't prevent the router from moving around under the table. To solve this problem, I created a "pocket" for the router on

the bottom of the table. To see how I did this, take a look at the box on the opposite page.

**Cut Grooves for Supports** – With the recess complete, the next step is to cut a series of shallow (1/8") grooves in the *bottom* of the table, as illustrated in Figure 2. These grooves serve the purpose of locating the two plywood supports that help stiffen the top of the table.

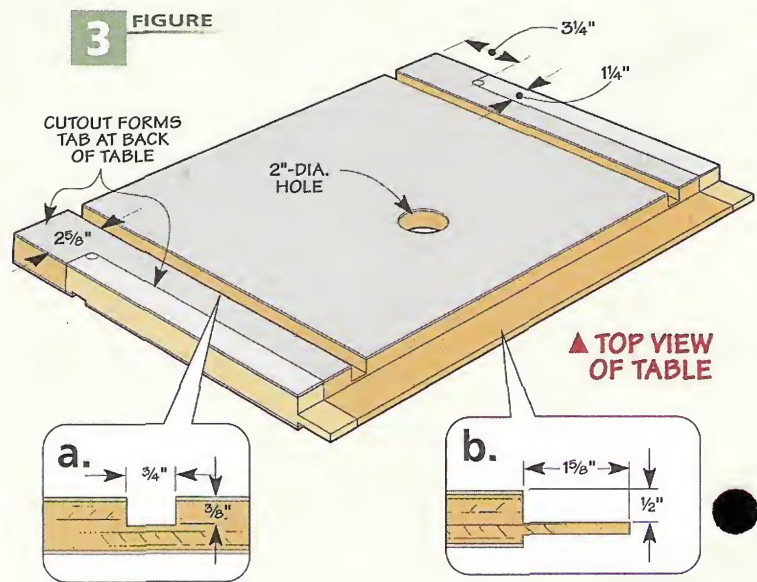
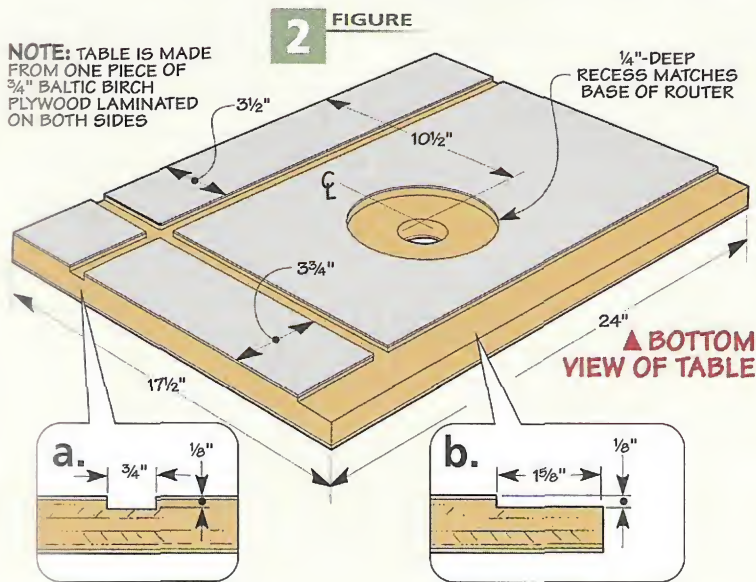



You'll also notice a shallow ( $1/8$ " ) rabbet along the front edge of the table. This is for a plywood lip that's added later. The lip supports the front edge of the top and also provides extra material for screwing the dual track in place.

**Add Grooves for Tracks** – Now you can flip the table over and work on the top side. The pair of grooves shown in Figure 3 run from the front to the back along each side of the table. These grooves accept the T-track used to attach the fence.

I used a dado blade sized to match the width of the T-track and cut just deep enough so the T-track was level with the top of the table, like you see in Figure 1b. And like the bottom of the table, there's a rabbet along the front edge. You can see in Figure 3b that this rabbet is cut a little deeper to accommodate the extra thickness of the dual track (Figure 1a).

Now all that's left to do to complete the top of the router table is to make a cutout along each side of the table. These cutouts leave tabs along the back edge allowing you to clamp

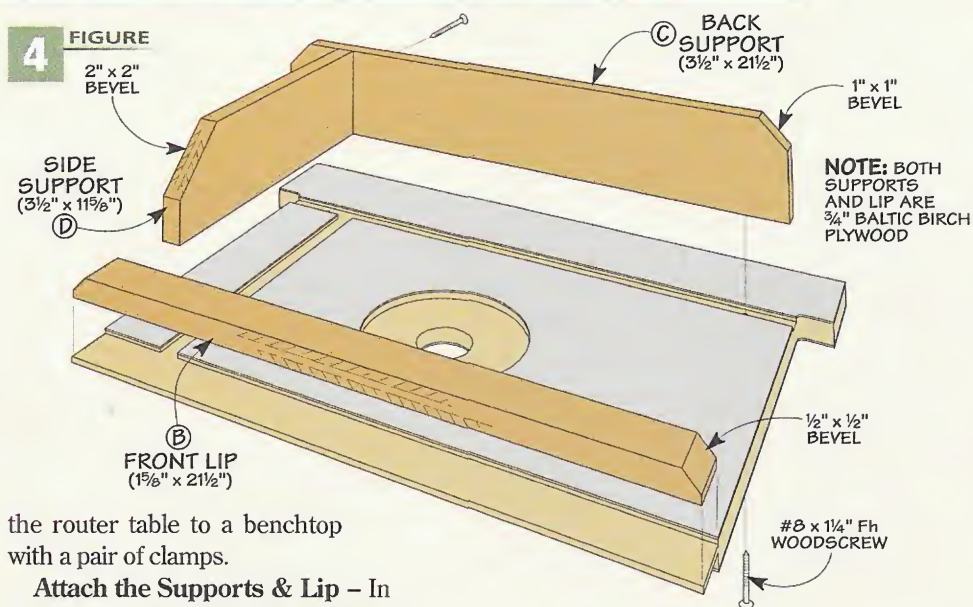

the router table to a benchtop with a pair of clamps.

**Attach the Supports & Lip** – In the bottom view shown in Figure 4 you can see how the table supports and front lip are attached. After cutting the  $3/4$ " plywood *front lip* (B) to size and beveling the ends, it's simply glued in place.

Next, cut the *table supports* (C, D) to size and knock off the outside corners. Then these pieces can be glued and screwed in place. Note: Locate the screws for the back support in the grooves for the T-track.

**Add the Hardware** – All that's left to do at this point is install the hardware. To locate the toggle clamps, it's best to flip the table over and set the router in place. This way, you can position the clamps clear of the router handles and controls.

Next, cut the dual track to length and position it so your miter gauge slides smoothly. Finally, cut the T-track to length and screw it in place.

## Making a Recess for the Router

The toggle clamps do a great job of holding the router against the table. But they won't keep the router from moving from side to side. A simple solution to this is to create a pocket in the bottom of the table to house the router.

**Circle-Cutting Jig** – To cut out the pocket, I made a simple circle-cutting jig from a piece of hardboard. After drilling a hole for a pivot pin (I used a  $1/4$ " machine screw), I attached the router to the jig with a couple pieces of carpet tape, as shown in the drawing at right.

The router is located so that the distance from the pivot point to the outside edge of the router bit ( $1/2$ " straight bit) is *half* the diameter of the router base.

After drilling a  $1/4$ "-dia. pivot hole in the table, rout a  $1/4$ "-deep circle. Once that's complete, you can drill the 2"-dia. clearance hole for the router bit. Then all that's left to do is remove the rest of the waste from the recess so the router will slip into place, like you see in the photo at right.

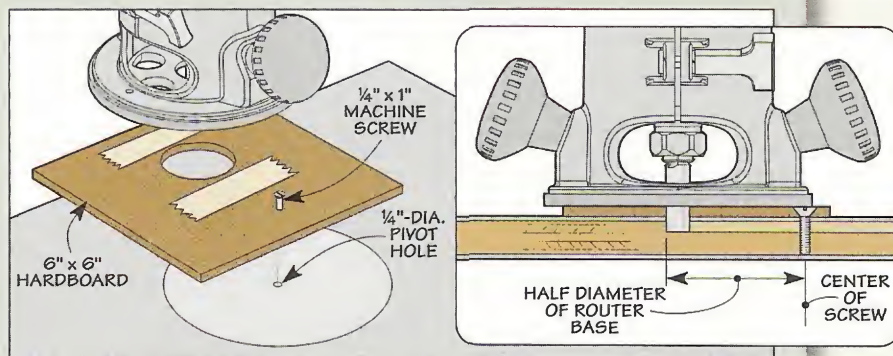



# Add a Fence

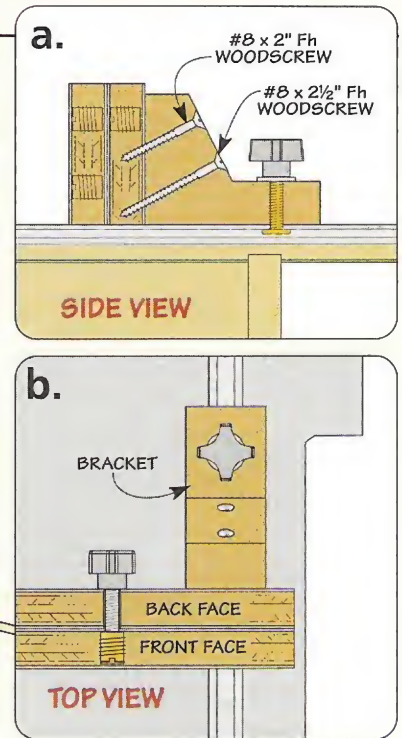
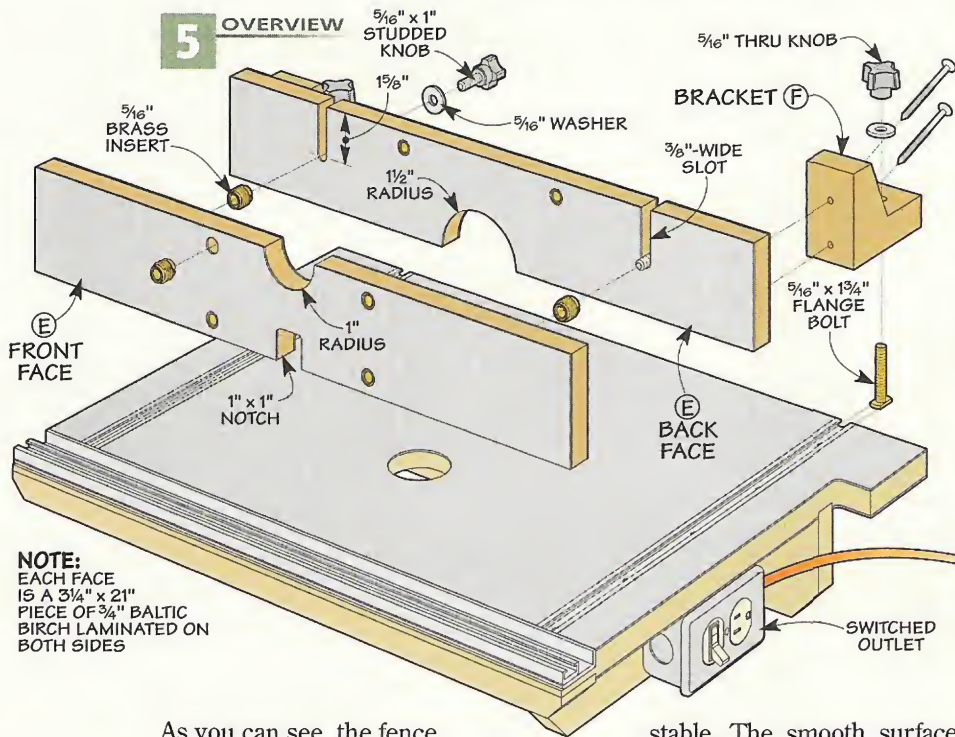

As you can see, the fence is made up of two faces attached to a pair of brackets. Why two faces? Simple. It makes it an easy task to quickly change the front face to the opening that better matches the bit you're using.

**Make the Faces** – I started on the fence by making the two face pieces. Both faces (E) start out as identical strips of 3/4" plywood. And like the table itself, I laminated both sides to keep the faces flat and

stable. The smooth surface also makes it easy to slide a workpiece along the face as you rout.

**Back Face** – After trimming the laminate flush on both face pieces, you can turn your attention to completing the work on the back face.

Figure 5 shows a large circular cutout centered along the bottom edge of the back face. This opening allows the dust hood to easily pick up dust and chips as they're created. And along the top edge of the back

face there are two slots. These slots are used to quickly slip the front face in place (Figure 5b). Making the slots is just a matter of drilling a hole at the end of the slot and then using a jig saw to remove the waste.

**Front Face** – For now, you can set aside the back face and begin work on the front face. Here again, I made a couple cutouts. But these cutouts simply provide clearance for the router bit. You can refer to Figure 5 to see the sizes.

To allow you to mount the front face to the back, there are a pair of threaded inserts installed in the back side of the front face (Figure 5). To read more about a great way to install inserts, refer to the opposite page.

On the front of the face you'll see four more inserts. These inserts allow you to attach the bit guard with the front face in either position. Finally, I installed a couple inserts in the back face so I could use the bit guard on that face if I ever needed to.

**Add the Brackets** – With the faces complete, all that's left is to add the mounting brackets. These brackets hold the fence in place on the router table and allow you to adjust its position easily.



▲ **Fence.** The front face features two different cutouts so you can match the opening to your bit. The square opening (left) works best for straight bits, while the circular opening (right) provides better clearance for larger profile bits.



**6** FIGURE

**FIRST:** MAKE END CUTS ON BAND SAW

**SECOND:** DRILL HOLES

**THIRD:** CUT BRACKETS TO LENGTH

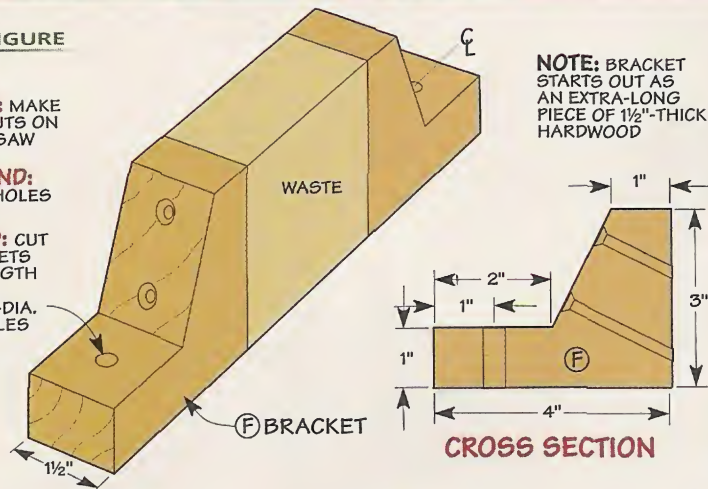

**Mounting the Fence.** Heavy-duty brackets keep the fence square to the table. To reposition the fence, you just loosen the knobs and then easily slide the fence right where you need it.

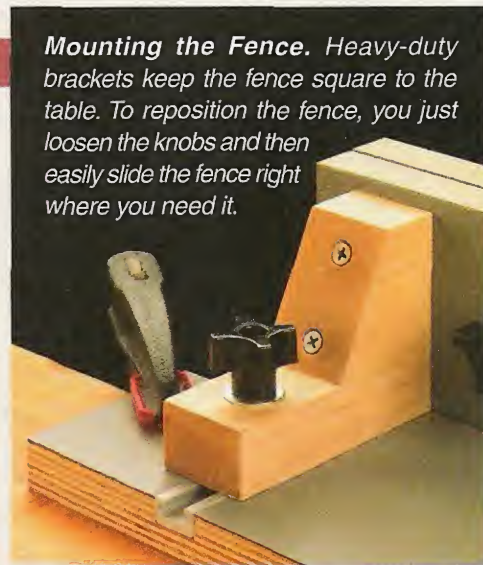

Because the brackets are somewhat small to work with, I started with an extra-long blank that I planed to final thickness and cut to final width (Figure 6). Then I removed the waste at each end by making the angled cuts on the band saw.

After sanding the surfaces smooth, you can drill the holes for mounting the brackets to the back face as well as the hole for the knob, washer, and flange bolt used to attach the fence and brackets to the T-track in the table.

Once that's complete, you can trim each *bracket (F)* to final size. Then screw them to the back face so they're flush along the bottom edge, like you see in Figure 5a.

**ELECTRICAL SWITCH**

Although the router table is ready to use at this point, there's one more thing you might want to consider. And that's adding a switched outlet (shown in the photo below).

With the router plugged into a switched outlet mounted on the side of the table, you won't have to search under the table to find the router switch. This is especially helpful if you need to turn the router off in a hurry.

To see a complete hardware list and view a drawing for hooking up a switched outlet, check out Online Extras on the *ShopNotes* website.

**Installing Inserts**

Installing a brass insert sounds simple. Just drill a hole and then screw the insert in place. Unfortunately, it's all too easy to lift the surrounding material and it can be a challenge to install the insert perfectly straight.

**The Right Technique** – But you can solve both problems by following a few simple steps.

The first is to drill a properly sized hole. I find it best to drill the hole to match (or even slightly exceed) the size

of the non-threaded portion of the insert. And then to avoid lifting the edges of the hole, chamfer the top of the hole to match the outside diameter of the threads on the insert.

**Install Insert** – Finally, to install the insert straight, I use a simple "jig" like you see in the photo. The jig is just a cutoff bolt with a pair of nuts "jammed" on it.



After chucking the bolt in your drill press, thread the insert on the bolt until it contacts the nuts. Then turn the chuck on the drill press *by hand* as you lower the quill. Note: You'll notice the insert is installed with the slot down. I prefer this because it provides a cleaner look. The downside — once the insert is in place you can't remove it.



**Switched Outlet.** Turning the router on and off is a breeze with a switched outlet mounted to the side of the router table.



*Don't be intimidated by big box joints. They're so simple to make, you don't even need a jig.*



# Super-Strong Box Joints on the Table Saw

**M**aking traditional box joints with a jig is a job that typically requires a lot of fussing around with stops and index pins to get a perfect fit. But if you're making long rows of tiny box joints,

using a jig is really the only way to get consistently good results.

On the other hand, when it came to making a handful of extra-large box joints for the benchtop vise (see page 14), I figured that there just had

to be an easier way. What I came up with is a simple technique that doesn't require a jig. Instead, you cut the box joints "by eye" on the table saw. It might sound difficult at first, but because these box joints are so few and so large, they are fairly forgiving. The truth is that you can have all the box joints cut and fitted in about half the time it would take you to set up and adjust a jig.

The technique I used to make these box joints is to simply lay out and cut the joints on one of the workpieces. Then I used that piece to lay out the joints on the face of the mating workpiece.

**Layout** – As with any joint, much of the success depends on a careful layout. I started by measuring and laying out the fingers of the box joint

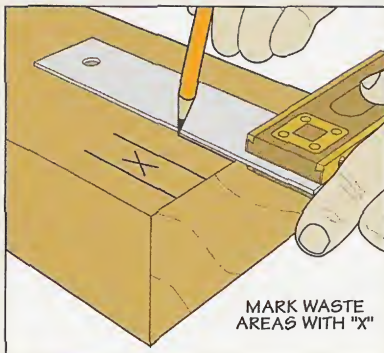

**1** Start by laying out the fingers on your workpiece and marking the waste areas with an "X."

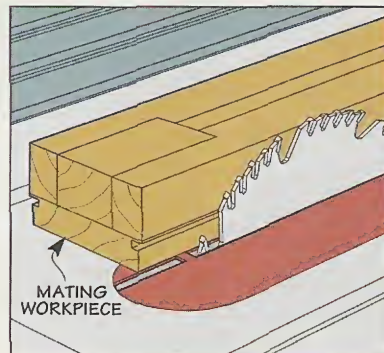

**2** Using the mating workpiece as a gauge, set the blade about  $\frac{1}{32}$ " higher than the workpiece.

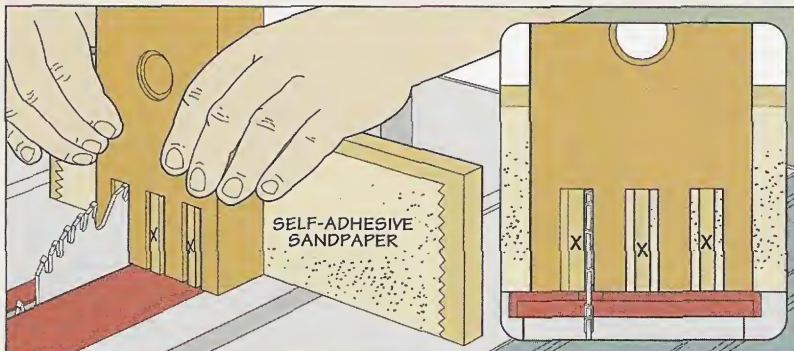

**3** To cut the fingers, start by cutting along the waste side of the layout lines. Then remove the material in between with additional passes. A tall auxiliary fence helps to back up the workpiece and prevent tearout.

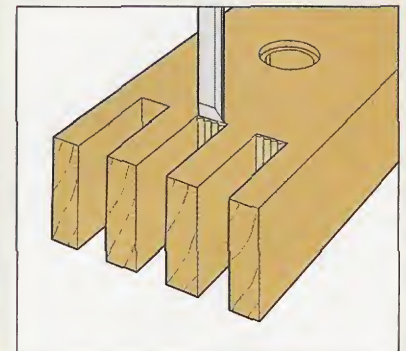

**4** A chisel is used to remove the ridges left behind by the saw blade at the ends of the slots.



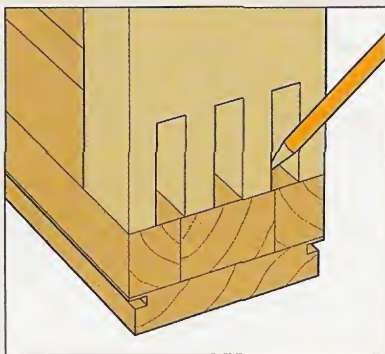

**5** Using the first piece as a template, lay out the fingers on the mating workpiece with a pencil.

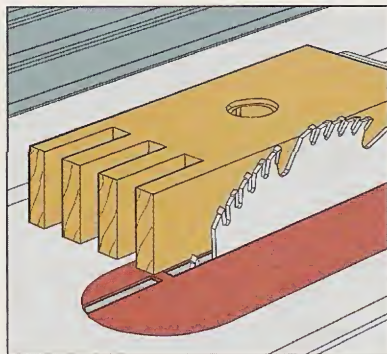

**6** To set the blade height for the fingers on the mating piece, the first piece is used as a gauge.

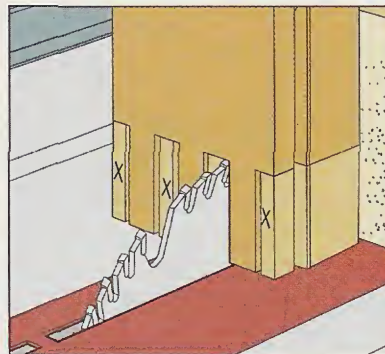

**7** Cut the fingers on the mating workpiece using the same procedure as before.

on the first workpiece, as shown in Step 1. Then I used the mating workpiece to set the height of my saw blade (Step 2). You actually want to raise the blade so it's just slightly higher (about  $\frac{1}{32}$ " ) than the thickness of the workpiece.

### CUTTING THE FINGERS

Because these fingers are so long, I couldn't cut them with my 6" dado set. So I used a single saw blade instead, as you see in Step 3.

I started by cutting right along the layout lines first to define the shoulders of each finger. Then I came back and cut away the waste with additional passes.

There are a couple of things to mention here. First, I added a tall auxiliary fence to my miter gauge. This helps support the workpiece and backs up the cuts to prevent tearout as the blade exits the workpiece.

Second, I added a piece of self-adhesive sandpaper to the front of the auxiliary fence. This prevents the workpiece from "creeping" while you're making the cuts.

**Clean-Up** – After cutting all the fingers, I took a chisel and cleaned up the ridges left behind by the saw blade at the ends of the notches (Step 4). When this is done, you're ready to start cutting the fingers on the second workpiece.

**Mating Piece** – To lay out the fingers on the mating workpiece, I used the first piece as a template (Step 5). Just set the first piece on top of the second and trace around the fingers

with a sharp pencil or marking knife.

If the second piece is a different thickness than the first (as is the case with the vise) you can use the first piece to set the height of the saw blade (Step 6). Then cut the fingers on the second piece just like you did with the first one (Step 7).

After cleaning up the ends of the notches, try fitting the two pieces together. What you're aiming for is a fit that's snug, but at the same time doesn't have to be pounded together. If you need to fine-tune the fit, you can shave a little bit off the sides of the fingers with a chisel.

**Assembly** – Once you've got the box joints fitted, you're ready for

some assembly. Because you cut the box joints a hair long, the ends of the fingers will stick out past the face of the mating piece. This makes it difficult to clamp up the joint. To get around this, I made some special clamping blocks (see photo below). Then after the glue is dry, all you have to do is sand the ends of the fingers flush with the surface, as you see in the inset photo below. 



◀ **Long Fingers.** To get a good fit, I like to cut the fingers of a box joint a hair longer than necessary. After gluing up the joint (using some custom-made clamping blocks), the ends of the fingers can be sanded smooth with the surface (see inset photo above).



# Shop-Made Benchtop Vise

**M**ost woodworking benches I've seen have at least one vise built into the top. So why would you want to build a vise to go on top of your bench if it already has a vise? The answer is simple. This vise does a number of things that an ordinary face vise can't.

To start with, the whole vise swivels so you can mount it at an angle to the front of the bench. This allows you to find the most convenient working position when clamping a workpiece in the vise. And if you have a large, curved, or odd-shaped workpiece, you can position the vise so the workpiece hangs off the edge of the bench.

Second, you'll notice that the jaws of the

vise are fairly tall. This is to lift the workpiece up to a more comfortable height for doing carving or other detail work. Also, getting the workpiece up off the surface of the bench gives you a little more "knuckle" room when you're using a spokeshave or hand plane.

Finally, unlike other vises that are permanently mounted to the bench in a fixed location, you can mount this vise just about anywhere on your bench where there's a dog hole. And when you're done with it, you can easily remove it and store it out of the way.

And if these aren't enough reasons to make you want to build this vise, try taking a look at the assortment of vise jaw faces on page 20, as well as the optional quick-release mechanism on page 21.

## Correction:

*ShopNotes 71*

The materials list on page 15 and Figure 7 on page 18 show the rear jaw face as 8½" long.

The correct dimension for this part is 9" long.





**EXPLODED VIEW**  
OVERALL DIMENSIONS:  
4 1/4"W x 11 1/8"H x 19 3/8"L

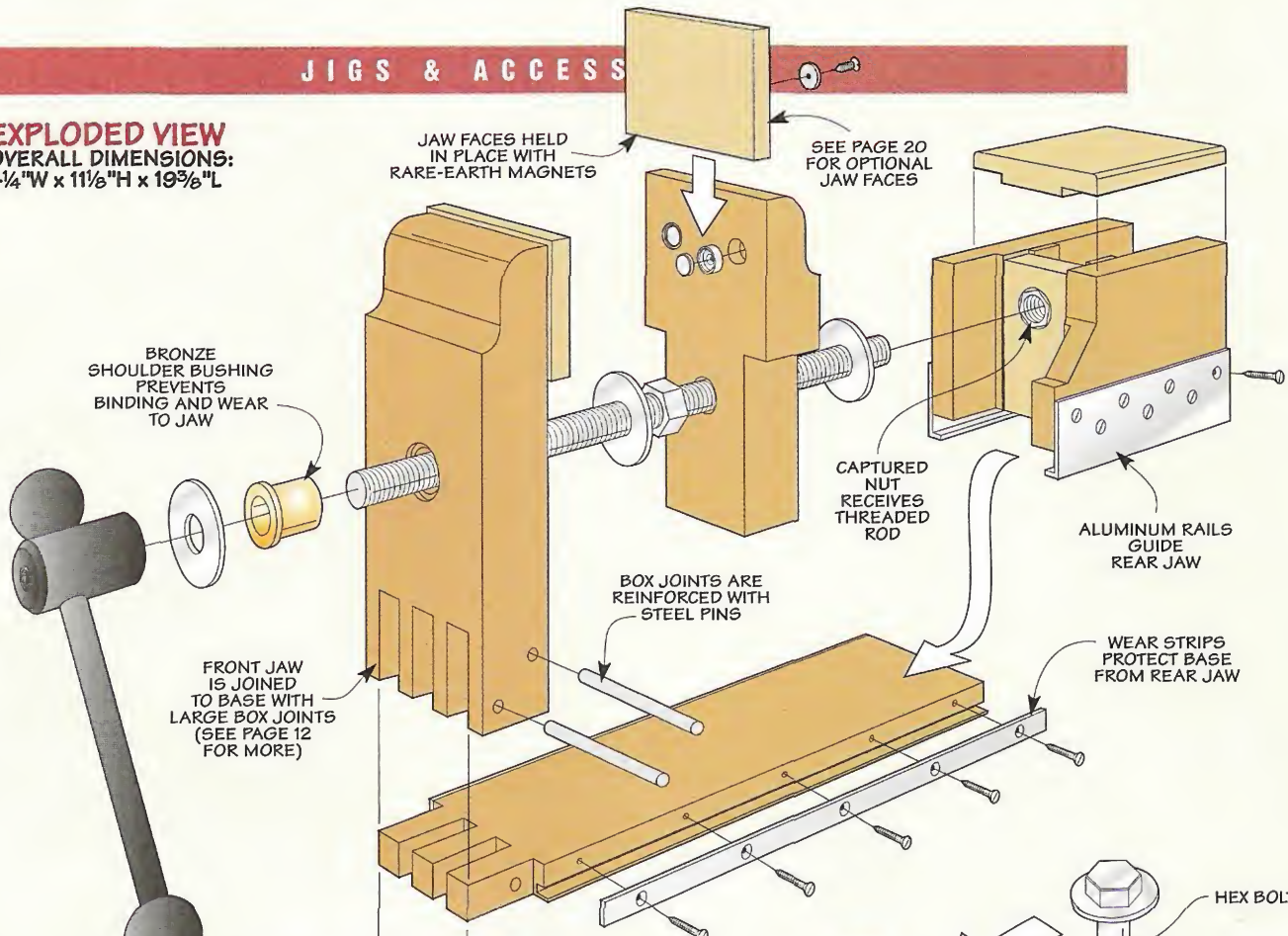

**Hardware**

- (10) #6 x 3/4" Fh Woodscrews
- (14) #8 x 3/4" Fh Woodscrews
- (1) 3/4" Hex Bolt (length to suit)
- (1) 3/4" x 15 1/2" Threaded Rod
- (1) 1/8" x 1/2" - 36" Alum. Strip
- (1) 2" x 2" x 1/8" - 36" Alum. Angle
- (1) 3/4" Nut
- (5) 3/4" Washers
- (2) 3/4" Coupling Nuts
- (1) 3/4" I. D. Shoulder Bushing
- (1) Clamping Handle
- (2) 1/4"-dia. Steel Rods (4 1/4" long)
- (4) 1/2"-dia. Rare-Earth Magnets
- (4) Steel Cups for Magnets
- (4-16) Steel Washers for Magnets
- (8-20) #4 x 1/2" Fh Woodscrews

**Materials**

A Front Jaw (1)	1 3/4 x 4 1/4 - 11
B Base Runners (2)	1 1/4 x 1 3/4 - 17
C Filler Block (1)	1 1/4 x 2 1/16 - 3
D Top Plate (1)	3/4 x 4 1/4 - 17
E Rear Jaw Face (1)	1 3/4 x 4 1/4 - 8 1/2
F Rear Jaw Sides (2)	3/4 x 4 3/4 - 7 1/2
G Rear Jaw Cap (1)	3/4 x 4 1/4 - 5 3/4
H Nut Block (1)	1 3/16 x 2 5/8 - 4 1/8
I Nut Block Retainers (2)	1/4 x 1 - 4 1/2
J Handle (1)	1 x 2 1/2 - 7 1/2
K Plain Jaw Faces (2)	1/2 x 3 - 4 1/2

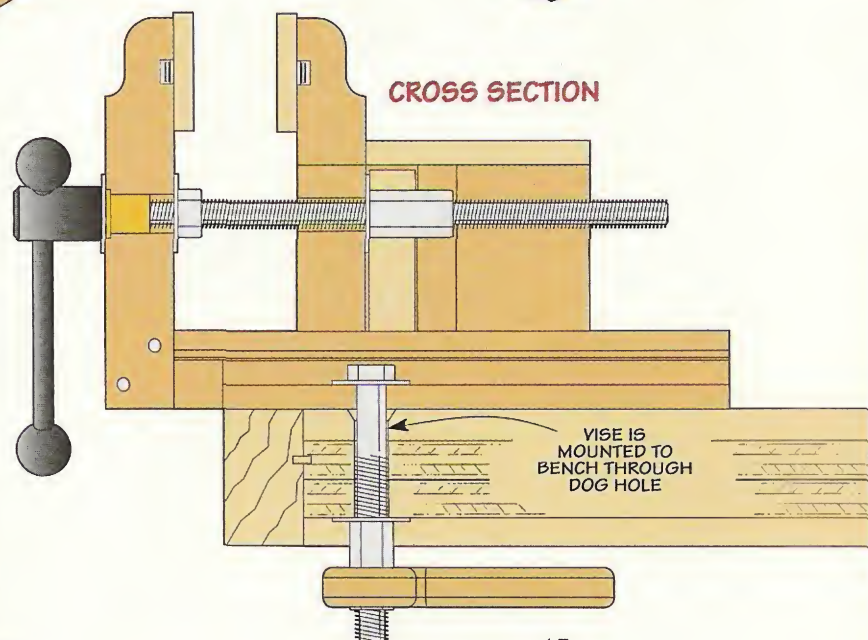
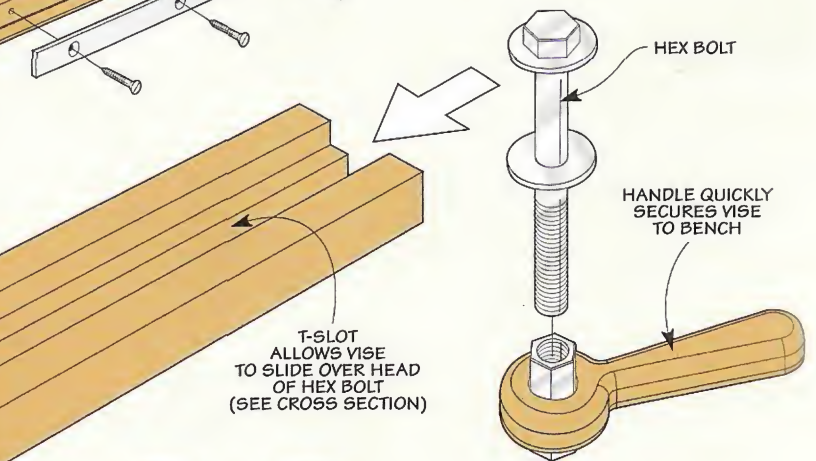



# Front Jaw & Base

The vise is made up of three main sections — a fixed front jaw, a base, and a rear jaw. The front jaw and base are joined together with box joints to create a single assembly, just like you see in Figure 1. So I built these two sections of the vise first.

**Front Jaw** – If you take a look at Figure 2, you'll see that the *front jaw* (A) is cut from a piece of 1 3/4"-thick hardwood stock. (I used oak.)

There's not much to making the front jaw. First, a counterbored hole is drilled in the jaw blank for a bronze shoulder bushing that will hold the vise screw (Figure 2). Then a pair of smaller holes are drilled in the face of the jaw for a couple of rare-earth magnets that will be used to hold some replaceable jaw faces.

To complete the jaw, all that's left is to add the ogee profile to the top of the blank as you see in Figure 2.

▲ **Clamping Handle.** This large, comfortable handle allows you to really tighten down the jaws of the vise. (See page 35 for sources.)

## 1 OVERVIEW

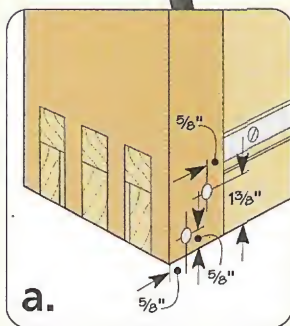
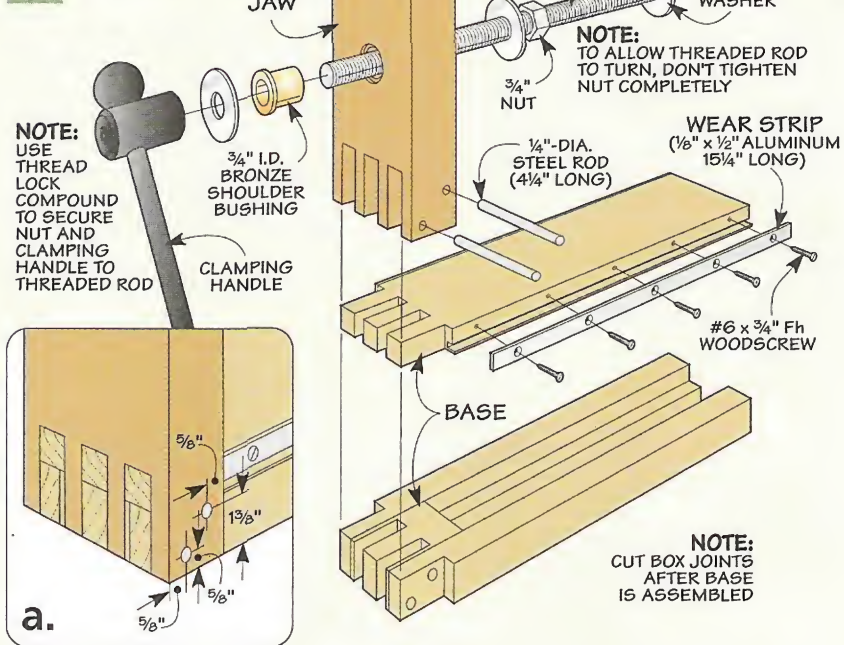

After laying out the ogee on the blank, I cut it to shape with a band saw. An oscillating drum sander or a drum sanding attachment mounted in your drill press makes quick work of sanding the ogee

smooth. Then you can set the jaw aside while you work on the base.

## BASE

If you take a look at Figure 3 on the opposite page, you'll see that the base is actually made up of four separate pieces. At first, you might wonder why I didn't just use a solid block of wood. The reason is the T-slot in the bottom of the base, which you can see in the Cross Section on page 15. This T-slot is sized to hold the head of a bolt that fastens the vise to the top of the bench. But instead of trying to cut the T-slot out of a solid piece of wood, I found it's easier to create it by gluing up four separate pieces.

To build the base, I started by making a pair of *base runners* (B) as shown in Figure 3. These two pieces start out as identical blanks. The first step after cutting them to size is to cut a rabbet along one edge.

Once you've rabbeted both pieces, you can trim off part of the shoulder on each piece, as shown in Figure 3. But be careful here. You're going to be creating a left and right runner, so pay attention

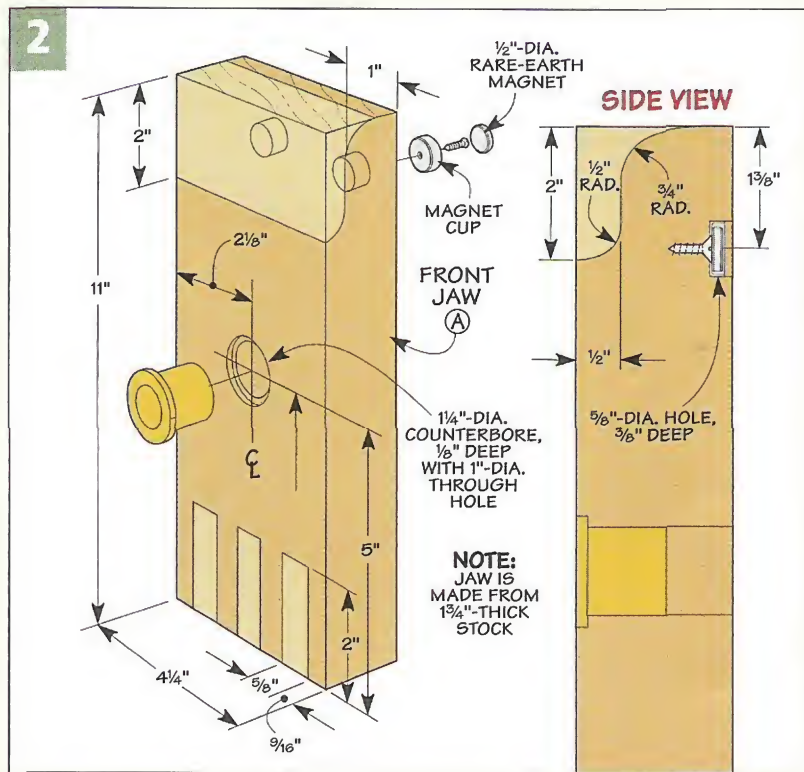



to which end of the workpiece you are trimming. If you need to, take another look at Figure 3 to see what I'm talking about.

**Filler Block & Top Plate** – With the runners complete, you can make the other two parts of the base. The *filler block (C)* is just a small block of wood that gets sandwiched in between the two runners. And the *top plate (D)* is a 3/4"-thick piece of hardwood that is sized to fit on top of the other three pieces of the base.

After cutting the filler block and top plate to size, you can glue up all the pieces. To help keep the runners aligned during the glue up, I made a small, temporary spacer to fit in between them, as shown in Figure 3a. Just make sure that you don't accidentally glue the block in place.

**Box Joints** – Once the base is glued up, you can cut the large box joints on the base and front jaw pieces. You can read all about how I cut these in the article on page 12.

Before gluing the box joints together, there are a couple of things left to do on the base. First, you'll need to create a couple of "tracks" in the sides of the base for the rear jaw

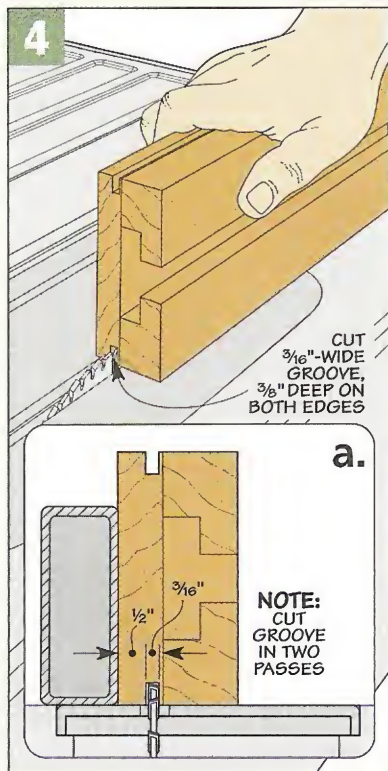
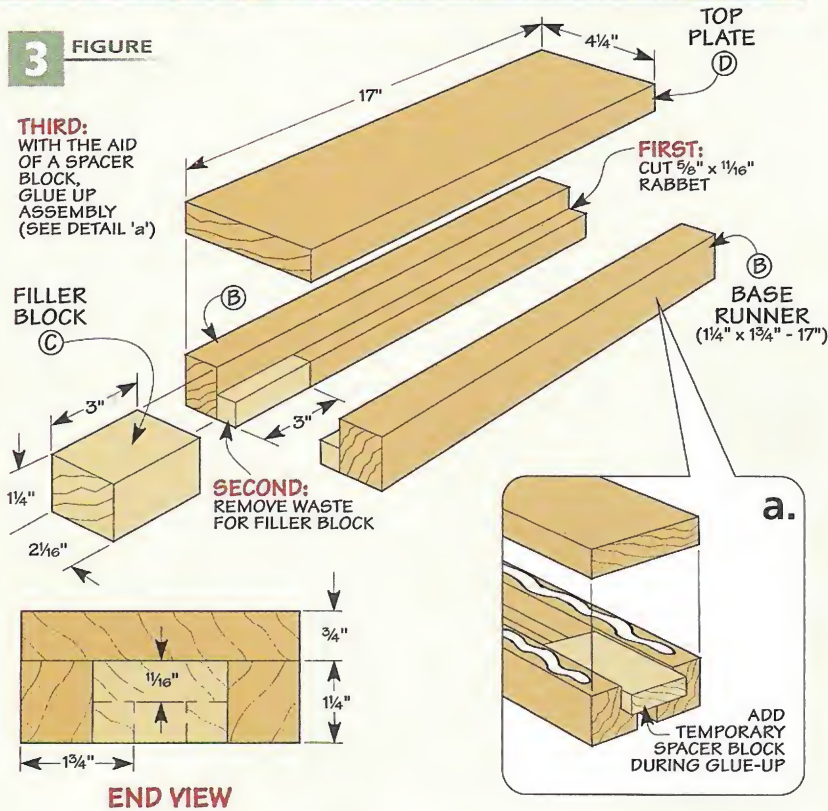

to run along. To do this, just cut a groove along each side of the base, as shown in Figure 4. Since these grooves are 3/16" wide, you'll have to cut each one in a couple of passes using a single saw blade.

To prevent wear to the base from the sliding action of the rear jaw, a couple of aluminum wear strips will be added to the sides of the base

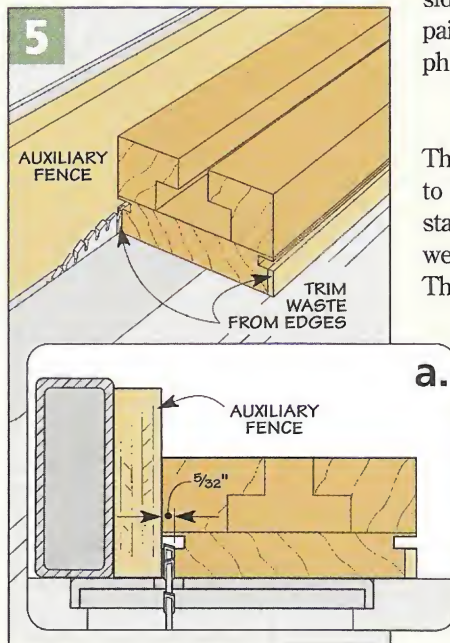

later. (These are shown in Figure 1.) These strips are let in to the sides of the base so that they end up flush with the surface. In order to do this, you'll need to trim back the edges of the base, as you see in Figure 5a. Once this is done, you can glue the base and front jaw together. To help reinforce the box joints, I drilled a couple holes through the sides of the front jaw and glued in a pair of steel pins (see Figure 1a and photo in margin at right).

**HARDWARE**

The last step is to add the hardware to the front jaw/base assembly. I started by attaching the aluminum wear strips to the sides of the base. The strips are cut to length with a hack saw and then simply drilled and screwed in place, as you see in Figure 1.

Next, I installed the magnet cups and magnets in the holes in the front jaw. Finally, I added the bronze shoulder bushing, the threaded rod and handle, a pair of washers, and a hex nut as shown in Figure 1. (See page 35 for sources.)



▲ **Pinned Box Joint.** To strengthen the box joint, I added a pair of steel rods to act as reinforcing pins.



# Rear Jaw Assembly

Now that you've got the front jaw and base finished, you can start working on the rear jaw assembly. The box-like rear jaw is built out of four separate pieces (Figure 6).

Aluminum rails attached to the sides of the rear jaw allow it to travel back and forth in the grooves in the sides of the base. And the threaded rod in the front jaw threads into a large nut captured inside the rear jaw. So when you turn the large handle on the front of the vise, the rear

jaw opens or closes.

To build the rear jaw, start by cutting out blanks for the rear jaw face (E) and the two jaw sides (F). If you take a look at Figure 7, you'll see that the first step is to drill a large hole through the jaw face for the vise screw. And just like on the front jaw, a couple of holes are drilled to hold a pair of rare-earth magnets that will be added later. Once this is done,

you can cut and sand the ogee profile on the top of the blank to match the profile of the front jaw.

If you take a look at Figures 7 and 8, you'll see that the jaw face is notched and the sides are rabbeted on the ends so that the pieces lock together when assembled. To do this, I started by cutting notches in the edges of the jaw face (Figure 7).

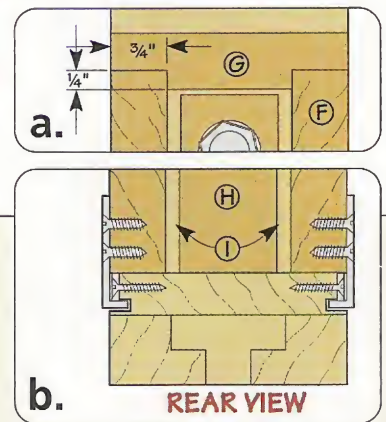
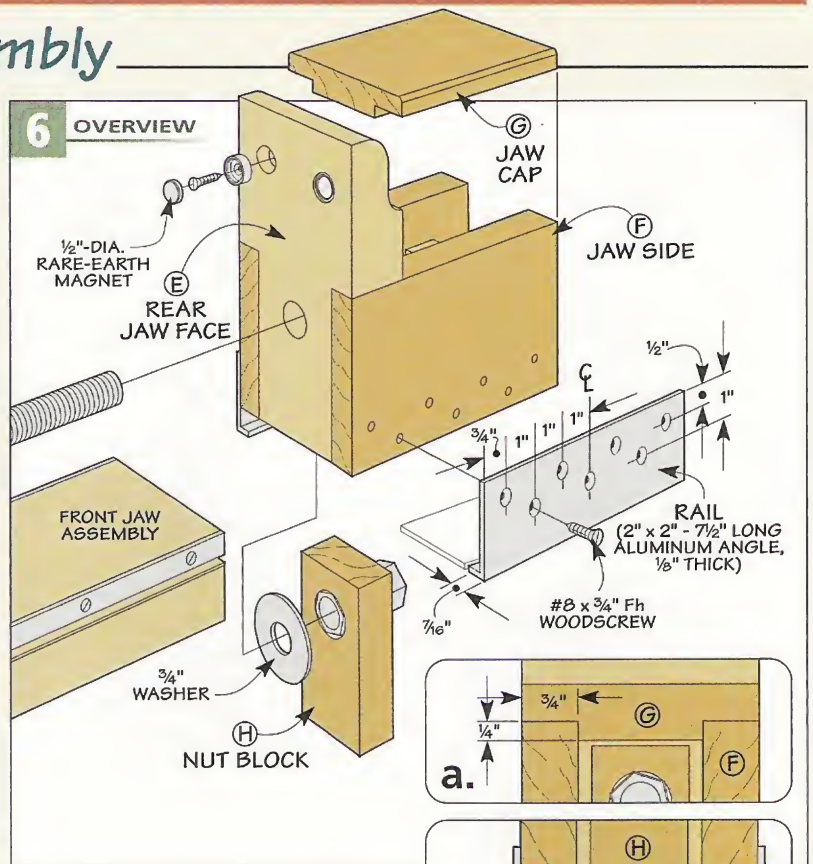

▲ Rare-Earth Magnet. This rare-earth magnet is mounted in a steel cup to increase its strength. The washer gets mounted to a removable jaw face.

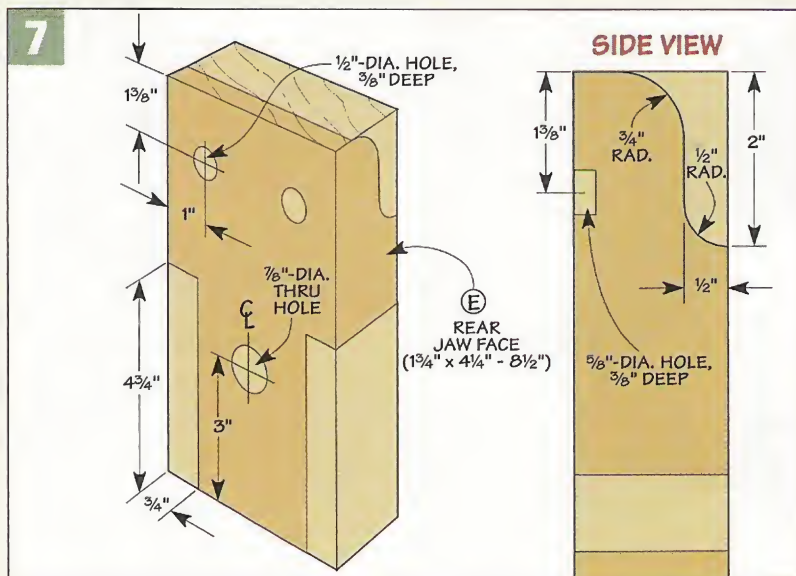

I just used a dado blade to nibble away this material.

Once this is done, you can cut a shallow rabbet at the end of each jaw side piece. You'll want to size these rabbets so that the side pieces fit flush with the edges of the jaw face.

**Jaw Cap** - With the face and sides of the rear jaw complete, you can set these pieces aside on your bench while you start working on the jaw cap. The purpose of the jaw cap (G) is to simply protect the threads of the vise screw from dirt and debris. The cap is cut from 3/4\"/>

**Nut Block** - It sounds like something you might get as a holiday gift from your great aunt. But the nut



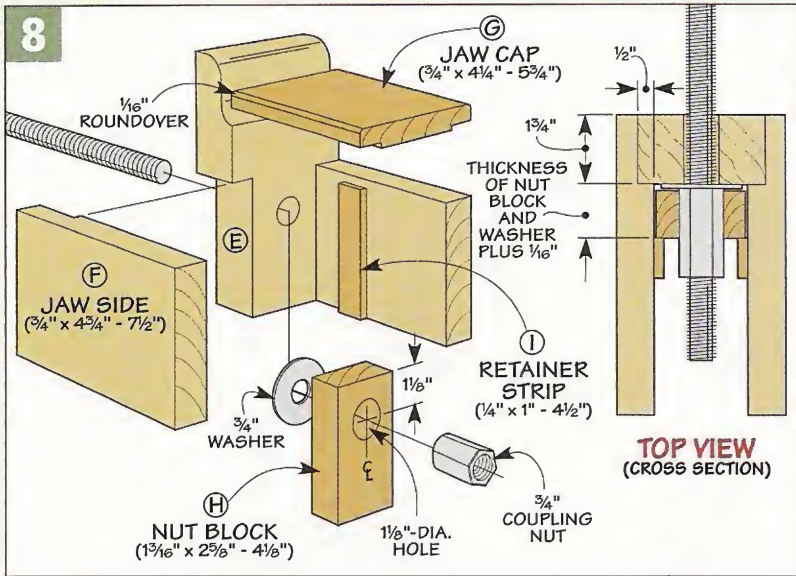

▲ A Winning Hand. Ordinary playing cards act as shims during the installation of the rails to create the necessary clearance between the base and the rear jaw.

block (H) is really just what the name says — it's a block of wood with a hole drilled in it to hold a large coupling nut. I glued the nut in place with a two-part epoxy.

To prevent the rear jaw from binding, the nut block is only held loosely in place by a pair of *retainer strips* (I). These are just a pair of thin wood strips that are glued to the sides of the jaw, just behind the nut block and washer, as in Figure 8.

This lets the nut block “float”

inside the jaw a little to give the vise screw some freedom of movement when you reverse direction.

**Rails** – The last thing to add to the rear jaw are the rails. As you can see in Figure 6, I made the rails by cutting down a couple of pieces of aluminum angle stock. Then I drilled some countersunk holes in the aluminum for the mounting screws.

To attach the rails, I set the rear jaw on the base of the vise with a couple of playing cards in between to

act as spacers. Then I clamped the rails to the rear jaw, drilled some pilot holes, and added the screws.

**Assembly** – To add the rear jaw to the vise, first slip the washer and nut block into place behind the rear jaw face. Then slide the rear jaw onto the base so the rails enter the grooves in the base and the threaded rod enters the hole in the rear jaw. (It helps to turn the vise upside down while doing this to prevent the nut block from falling out of the rear jaw.) Now all you have to do is turn the handle on the front of the vise to thread the vise screw into the nut block in the rear jaw.

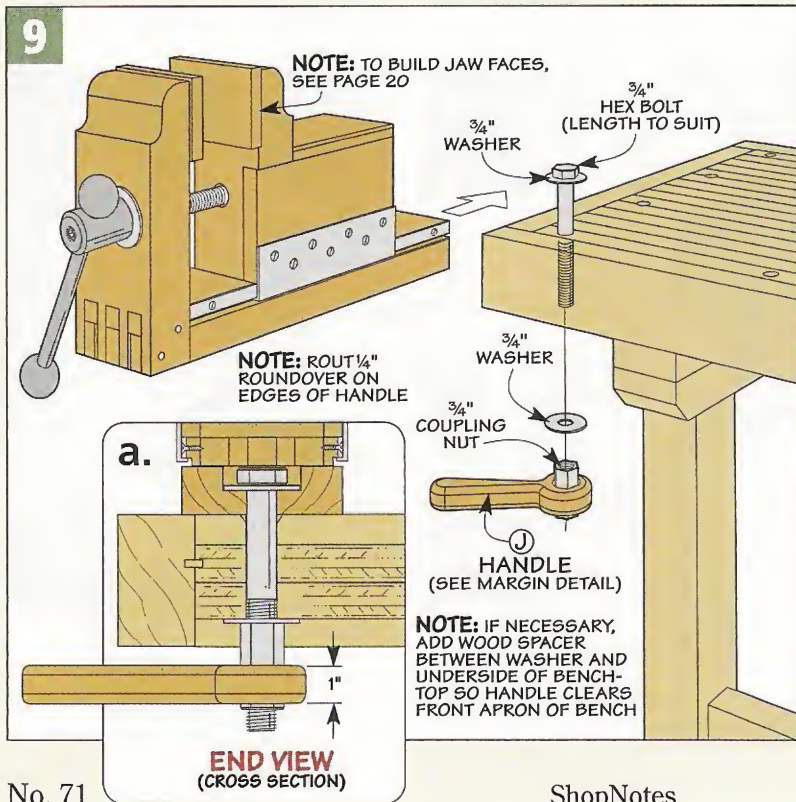

**HANDLE**

The vise can be attached to the top of a workbench with a large hex bolt, a coupling nut, and a pair of washers. The only thing left to make at this point is a wood handle for the nut (Figure 9). This way you can tighten or loosen the nut without having to get out a wrench each time.

The *handle* (J) is made from a 1"-thick hardwood blank. After laying out the profile on the blank and drilling the hole for the nut (see drawing in margin), you can cut the handle to shape and round over the edges. Finally, glue the coupling nut into the hole in the handle with epoxy and tighten it onto the hex bolt (Figure 9a).

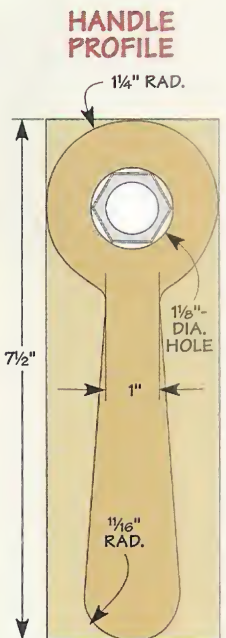



# Jaw Faces

The last thing to do to complete the vise is to make a set of replaceable jaw faces. In fact, I made four sets — a set of plain ones and then three optional sets of special-purpose jaw faces. The nice thing about all of these jaw faces is that they are held in place with rare-earth magnets. So it's easy to swap in another set.

**Plain** — The first pair of *jaw faces* (K) I made are just plain hardwood faces as you see in the photo on page 14. If you're only going to make one pair of jaw faces, these are the ones to make. They are made from 1/2"-thick hardwood stock.

The magnetic system I used to hold the jaw faces in place consists of three parts. The rare-earth magnets fit into steel cups that are mounted in holes in the vise jaws. Then a pair of washers are screwed to the back of each jaw face so that it will "stick" to the magnets.

But instead of countersinking the washers, I just screwed them in place on the surface of the jaw faces so they stand proud. Since the magnets are recessed into the jaws on the vise, the washers will fit into the holes for the magnet cups and keep the jaw faces aligned.

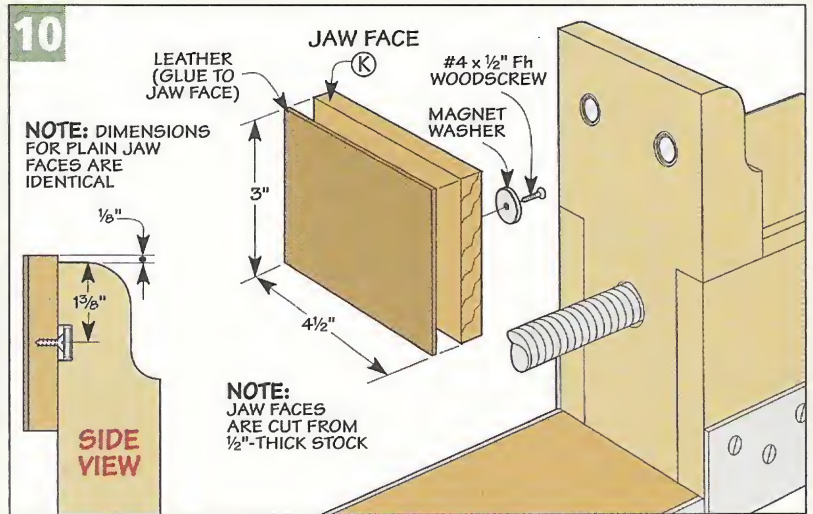

The only tricky thing about doing this is that you have to be careful when it comes to laying out the position of the washers on the jaw faces. They need to match up exactly with the position of the magnets.

**Soft Jaws** — The plain jaw faces are fine for most work. But when you don't want to take a chance on marring your workpiece, it's nice to have a set of soft jaw faces (see left photo below). These are identical to the plain hardwood faces, but they are lined with leather for a soft, non-slip grip (Figure 10).

**Prismatic Jaws** — For holding round objects like pipe or dowels, I made a set of "prismatic" jaws. If you take a look at Figure 11, you can see that these jaw faces are made from 3/4"-thick stock. They have V-grooves routed on the faces in two different directions so that you can hold round objects vertically or horizontally (see center photo below).

**Swiveling Jaw** — The final jaw face that I made is one that swivels to hold tapered workpieces (see right photo below). You can see how this



**Soft Jaws.** For holding delicate objects (like carvings), these leather-lined jaws provide a firm but non-marring grip.



**Prismatic Jaws.** The V-grooves in this pair of jaw faces allows you to hold dowels or round stock either horizontally or vertically.

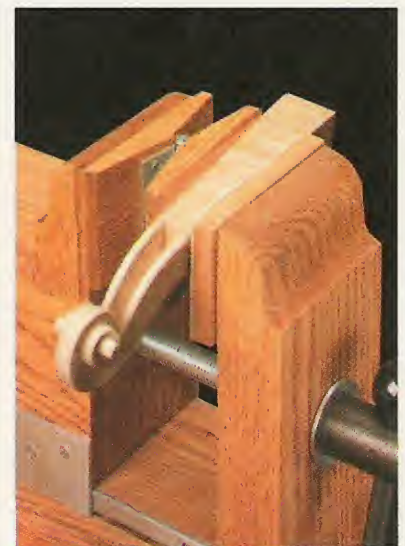

**Swiveling Jaw.** A hinge allows this jaw face to swivel, making it possible to clamp up tapered or non-parallel workpieces.



jaw face is put together by taking a look at Figure 12. The jaw face is actually made up of two halves that are joined together with a hinge.

After cutting the two pieces of the jaw face to size, you'll need to cut a couple of bevels on one side of each piece. (This provides clearance so the front half can swivel from side to side.)

In order to attach the hinge between the two pieces, you'll need to use a hinge with a removable pin. This allows you to separate the hinge into two halves so that each half can be screwed in place. Once this is done, all that's left is to line the face of the swiveling jaw with leather.

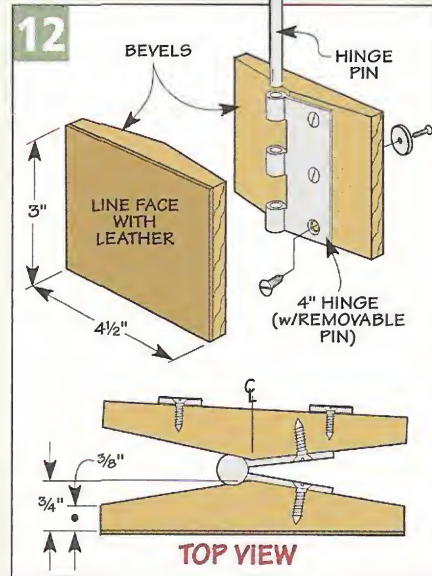
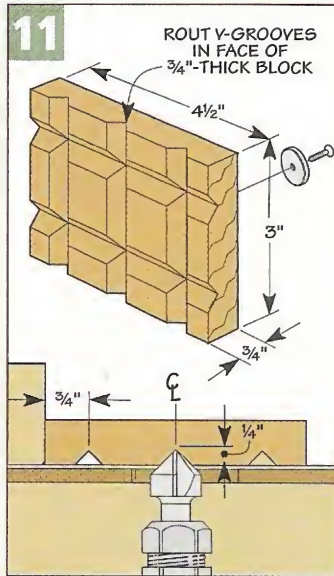

## Cam-Lever Quick-Release

Although the benchtop vise works great, it does have one drawback. It takes quite a few turns of the handle for the rear jaw to travel from one end of the threaded rod to the other. To speed up this process, we came up with a quick-release option.

The secret behind the quick-release mechanism is a "half nut" to replace the nut block. (I made this by sawing a coupling nut down the middle.) A spring-loaded cam mechanism is used to engage and disengage the half nut with the threaded rod.

**ShopNotes** For additional information on the quick-release version of the vise, go to [www.shopnotes.com](http://www.shopnotes.com).

**GO ON-LINE EXTRAS**

When the cam presses the half nut against the threaded rod, the vise operates as normal. But a simple flip of the lever on the side of the rear jaw releases the cam and allows the half nut to disengage from the threaded rod. Now you can slide the rear jaw to any position along the base.

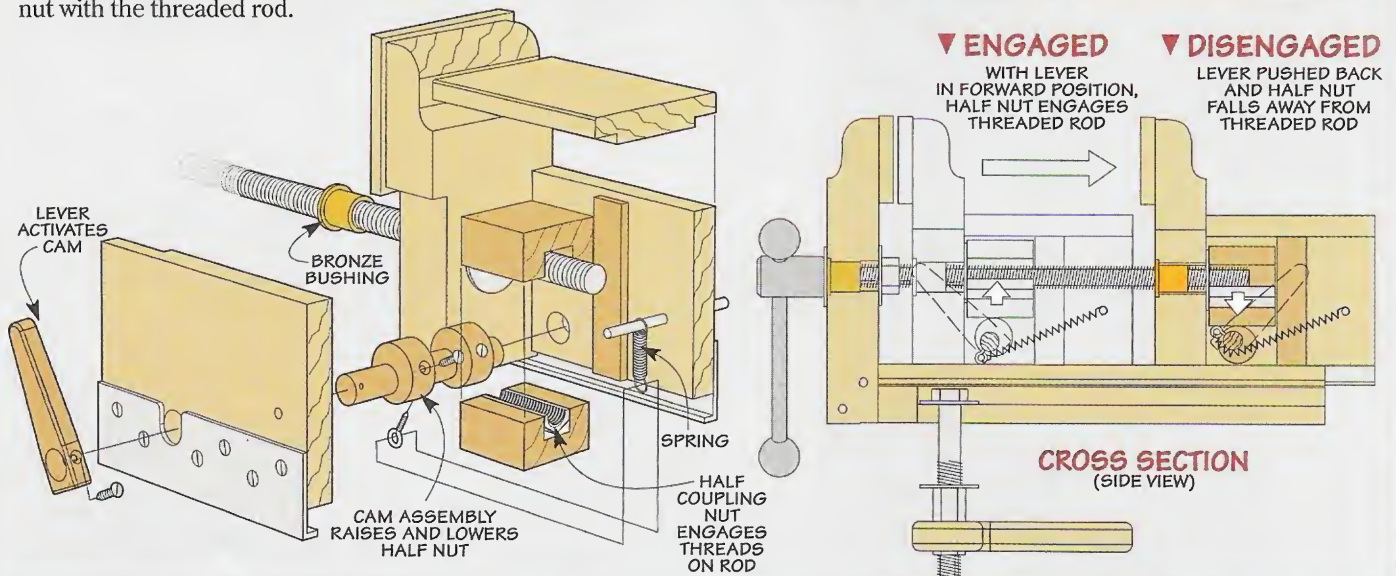



# 7 Shop Secrets for Working with Plywood

*Plywood has its challenges. It's heavy and cumbersome to work with. And the edges and veneer are prone to being damaged. But with a few of our shop secrets, you can meet each and every challenge.*

## 1. Easy Loading

■ The first step in dealing with plywood is just getting it into your vehicle — and then back out once you get it to your shop.

I came up with a way to do this with an old appliance cart (see photo). With the cart resting on the tailgate (with the wheels up), I lift one end of the sheet onto the wheels. Then I pick the other end up off the ground and “roll” the sheet into the bed of the pickup. To get the sheet out, simply reverse the process.



## 2. Move it Along



■ Once you get the sheet of plywood home and out of the truck, you'll need to move it into the shop. To avoid having to carry it around the shop, I made a “skateboard” from a piece of scrap 2x6 and a set of casters, like you see in the photo at left.

To ensure the plywood doesn't slip off the top as you're moving the sheet around, there's a shallow groove cut down the center of the top, as illustrated in the drawing below. And to make it easy to steer, the caster at the front swivels.

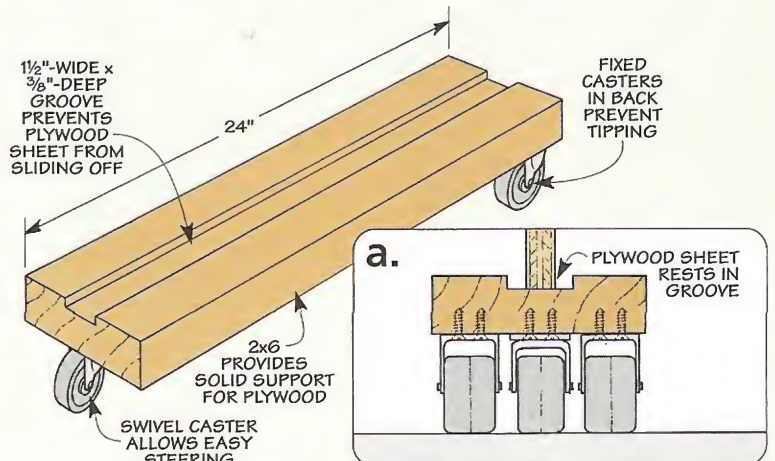



### 3. Quick & Easy Tote

Rolling a sheet of plywood around is quite easy. But sooner or later you'll need to carry a plywood sheet to get it right where you need it. When that's the case, I use the "handy" tote shown in the drawing and photo at right.

The tote is designed to hook under the bottom edge of the plywood. A round handle that fits into the sides of the tote is easier on your hand than the sharp edges of the plywood. And the extended sides on the tote make it possible for me to pick up a heavy sheet by lifting with my legs — rather than my back.

Note: When using the tote, be sure to center the plywood sheet on the support for better balance. And to prevent the plywood sheet from tipping, place your other hand at the top of the sheet to steady it.

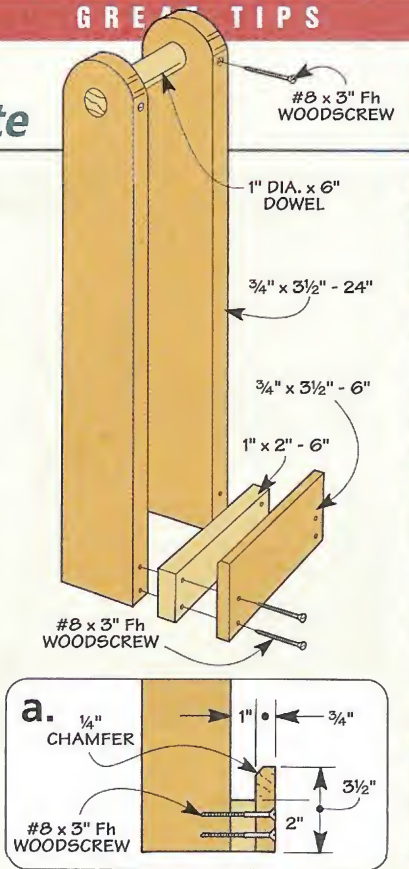

### 4. Up Against the Wall

I like to cut up the plywood for my project right away. But there are times I can't always do that. So I came up with a way to store plywood sheets nice and flat until I can.

All you need to do this is some free wall space and the storage bracket shown in the photo and illustrated in the drawing below.

The wall bracket consists of two parts: a hinged bracket attached to the wall that holds the plywood in place, and an index bar that adjusts

the opening of the bracket to allow for varying amounts of sheet goods.

The hinged bracket is nothing more than two 2x4s joined together at one end with a 3" butt hinge. You'll also notice that there's a 1/2"-dia. dowel glued into the top of each 2x4.

These dowels fit in holes drilled into the index bar so you can adjust the front bracket piece. The plywood is held against the wall with another 1/2"-dia. dowel (8" long) that's glued into the bottom of the front bracket.

I ripped the index bar to width from a short length of 2x4. Once you have it cut to size, the holes can be drilled. Then, to soften the sharp corners and allow the index bar to clear the wall, I sanded a radius at each end of the bar.

To use the storage bracket, select a hole in the index bar that takes the most slack out of the front bracket. When you want to sort through the stack, just set the index bar so the dowels are in the outside holes.

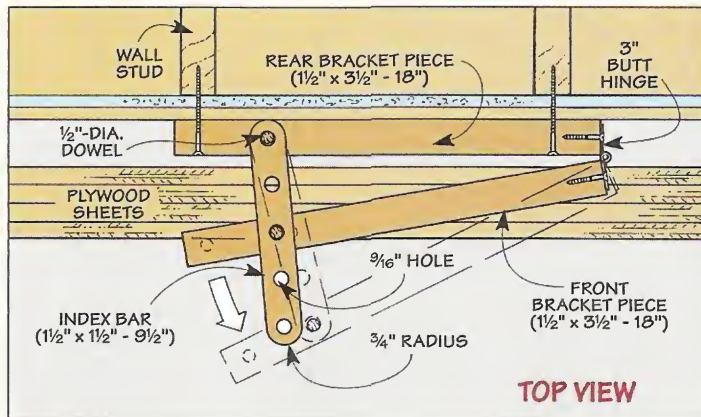
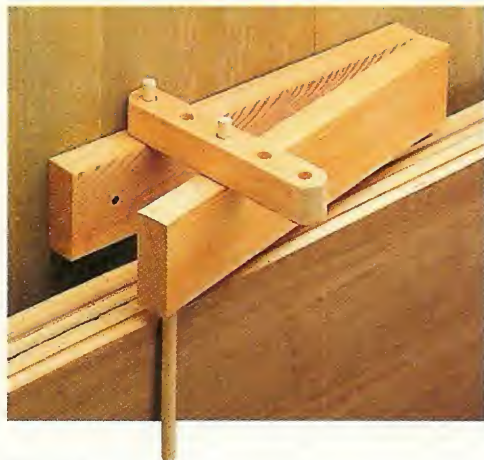



## 5. Build a 2-in-1 Cutting Guide

■ One of the biggest challenges when working with plywood is cutting a large sheet down into pieces that are a little easier to handle. Even with help, it's a hassle to cut plywood on a table saw. To avoid this, I use my circular saw and a cutting guide like you see in the photo at right.

The cutting guide not only solves the problem of making a straight cut, but it makes it easy to position the saw so you know exactly where the cut is going to be.

**An Accurate Reference Edge** – The way this works is simple. The edge of the guide acts as a reference that indicates the path of the blade (or router bit, but more about that in a minute). Ensuring an accurate cut is just a matter of aligning one of the edges of the guide with the layout line on the workpiece.

**Build the Guide** – There's nothing too complicated about making the cutting guide. Start out with an extra-wide base made from 1/4" hardboard (see drawing below).

The next step is to glue and screw a plywood fence to the base. Since the fence is going to establish the reference edge, it's important to attach it so it's perfectly straight.



Once the fence is in place, you can create the reference edge by trimming off the waste with a circular saw. The nice thing about the extra width on the base is that by using a hand-held router and a straight bit, you can create a second reference edge on the other side of the guide.

### THE CUTTING EDGE

Although the guide will make a straight cut with either a circular saw or a hand-held router, it won't always guarantee you a chipout-free cut.

When I'm using my circular saw, I like to use a *steel* saw blade designed specifically for plywood, like the one shown in the margin. But when using my table saw or router, I use a different blade or bit. To learn a little more about these, check out the box below and Sources on page 35.

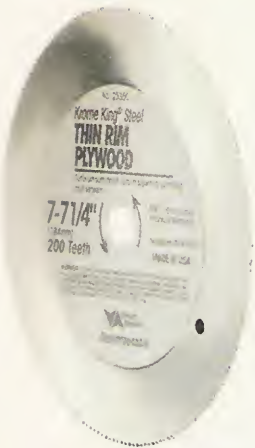

▲ **Circular Saw Blade.** To help reduce chipout, the inexpensive, steel saw blade shown above has tiny, razor sharp teeth that remove small amounts of material.

### END VIEWS

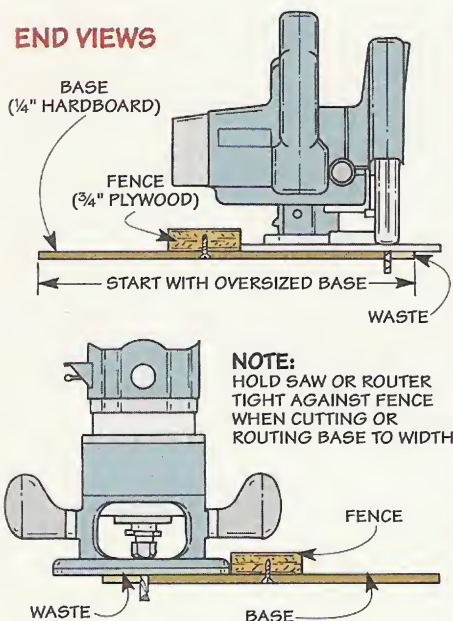

## The Cutting Edge

◀ **Compression Bit.** Combining up and down shearing flutes eliminates chipout on both faces of a sheet of plywood by "compressing" the cut to the center of the sheet. They're sold with either single or double flutes (double shown at left).

▶ **Plywood Blade.** Designed to produce a superior cut on both the top and bottom of laminates and melamine, this triple chip grind blade with a negative hook angle works equally well when you're cutting plywood.





## 6. Breaking Down Big Sheets

■ Before making any cuts, you'll need to lay out the pieces on the plywood first. It's a good idea to allow a minimum of 1/4" extra all the way around to provide enough material to make the final clean-up passes later.

Still, cutting plywood to rough size doesn't mean you want a ragged cut. The goal is to end up with clean, straight edges that can ride against the rip fence (or be placed against a miter gauge or an auxiliary sled).

**Foam Support** – To accomplish this, I use the cutting guide and saw

blade I mentioned earlier. In addition to the guide, you'll also need a way to support the plywood during the cut. The best way I've found to do this is to lay the plywood on a sheet of foam insulation, as in the photo at right. (I got mine at a local home center.)

**Keep the Good Side Down** – One thing to be aware of is the blade on a circular saw cuts on the *upstroke*. This means the top sur-

face of the plywood is likely to splinter. So even with a specialty blade that reduces chipout, it's best to place the plywood with its good face down on the foam.



## 7. Get a Perfect Finish Cut

■ One of the reasons for allowing a little extra material is to remove the "factory edge." You can usually count on this edge to be straight and true. But it's often dented or nicked. So it's best to trim it off.

To do this, adjust the rip fence to make an extra-wide cut, as in Figure 1. Then, after readjusting the fence, run the "just-cut" edge against it and rip the piece to final width.

One problem area is crosscutting a wide piece. Trying to do this often results in the bar of the miter gauge not being fully supported, resulting in a less than accurate cut.

**Sliding Platform** – The solution is a large, sliding platform that provides extra support for the workpiece, like you see in Figure 2.

The platform is just a plywood base that carries the workpiece through the blade. The base is guided by a hardwood runner that slides in the miter slot. As you make a cut, a fence keeps the workpiece square to the blade.

**Flush Trim It** – Sometimes a workpiece is too wide even for the sliding platform. That's when a hand-held router comes in handy.

With the cutting guide and a compression bit (see opposite page), you can cut a clean, straight edge without any chipout (Figure 3).

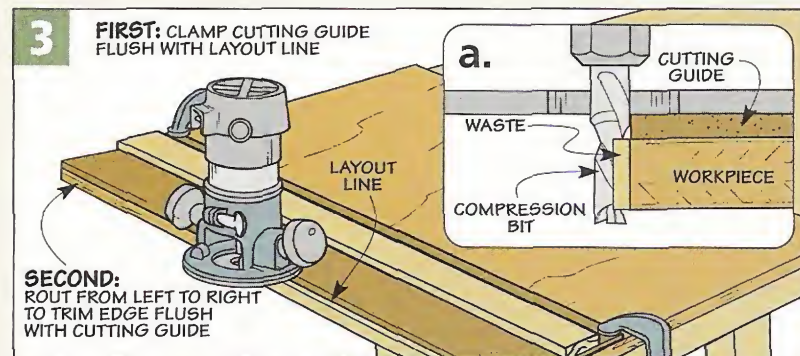
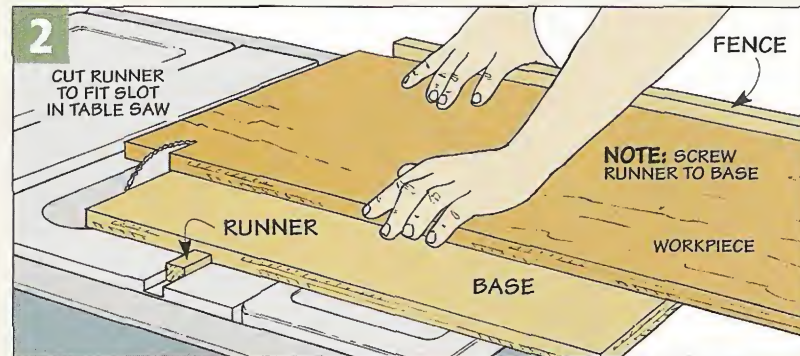
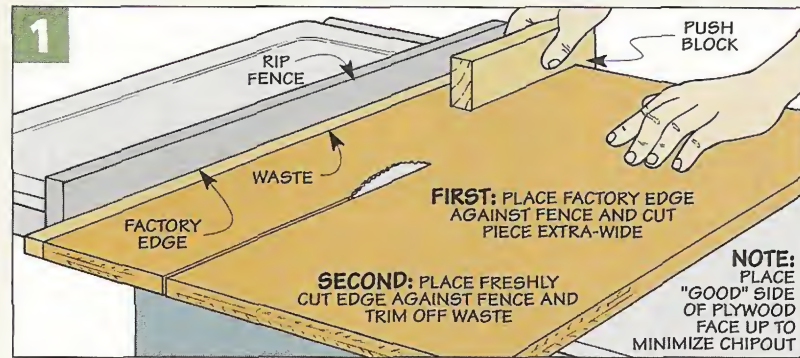



# 5 Plywood Shop Projects

*Five projects — five sheets of plywood. And each one can be built in just a couple of hours.*

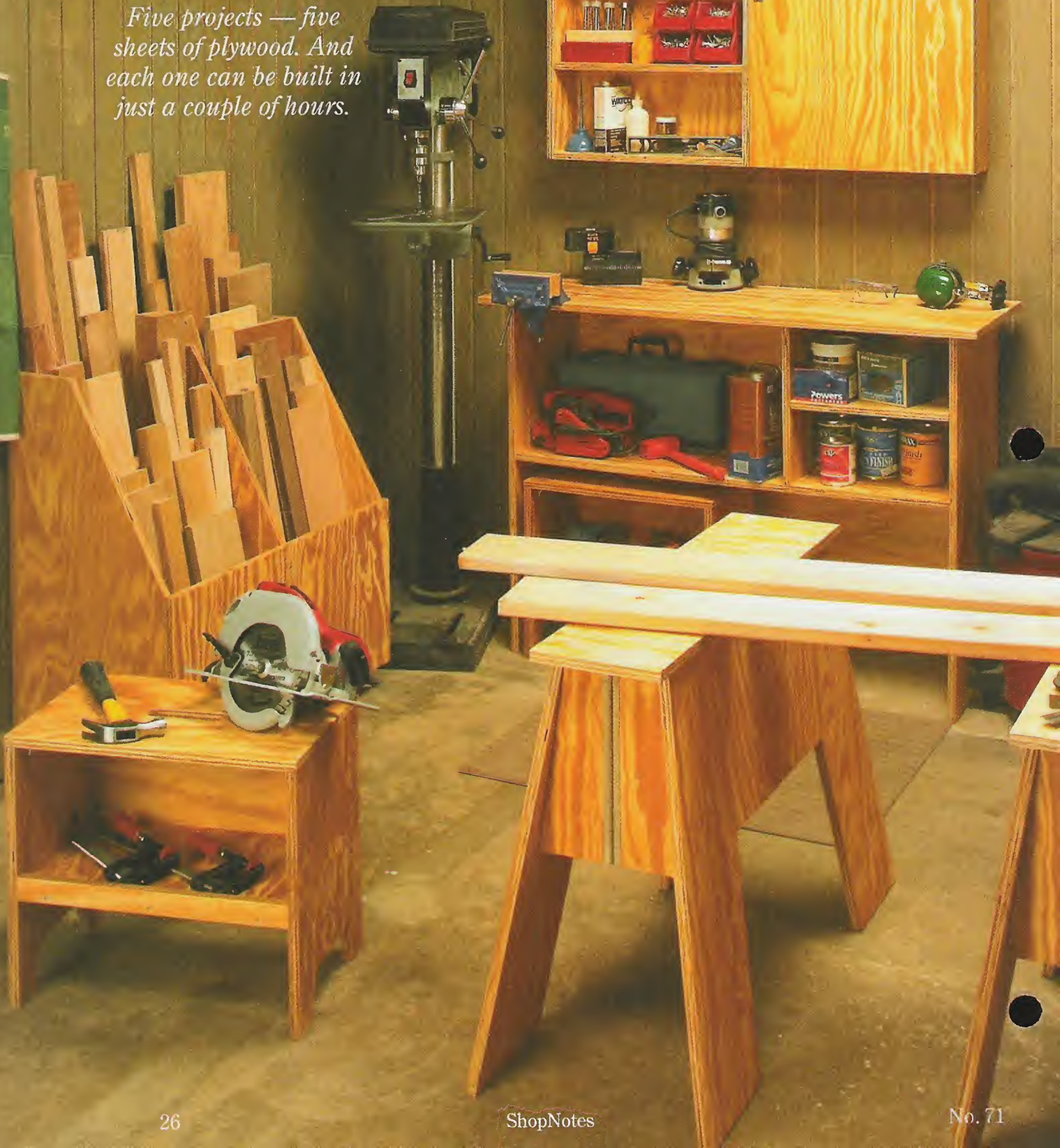



# Tool Tote

As much as I enjoy woodworking in my shop, I find that I spend almost as much time working on projects around the house. And because that usually involves carrying tools to where I'm working, it's nice to have something to carry them in. That's where these tool totes come in. Each tote is open on one side to make it easy to load and unload your tools. And a narrow cleat along the front edge of the opening prevents small items from falling out.

Not only does the tote hold an armful of tools, but it's just the right height for sawing the end off a board. In fact, you can make a pair of them to use as mini-sawhorses. And when you want to take a break, the tote makes a great little stool.

The tool totes are so small that you only need half a sheet of 3/4" plywood to build a pair of them (see cutting diagram below). To build the tool totes, start by cutting the ends (A) to size as shown in Figure 1. The "feet" can then be cut out on the ends using a band saw or a jig saw.

After you've finished making the end pieces, you can set them aside while you cut out the bottom (B),

back (C), and front cleat (D) of the tote. There's nothing out of the ordinary here — I simply cut the pieces out according to the cutting diagram.

**Assembly** – The tool totes are assembled with yellow glue and screws. To make sure everything lined up accurately, I dry clamped all the pieces together first and then drilled the pilot holes for the screws. Then I removed the clamps, glued the pieces together, and added the screws. I started by screwing the bottom and back together and then adding the front cleat.

The bottom/back assembly gets sandwiched between the two end pieces. Again, I used screws and glue to attach the ends.

**Top** – The last piece to add is the top. The top (E) also doubles as the "handle" for the tool tote (see photo above). So after cutting this piece to size, you'll need to cut out an opening in the center. I made this

slot by simply drilling a starter hole at each end point of the opening and removing the waste in between with a jig saw. Then for a more comfortable grip, I eased the edges by sanding them lightly.

To attach the top, I used some metal corner braces (see photo in margin). These are just screwed to the inside faces of the end pieces and then to the underside of the top, as you can see in Figure 1b.



▲ **Corner Braces.** These metal corner braces provide a quick and easy way of securely attaching the top of the tote.

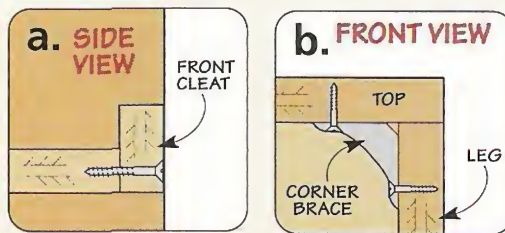
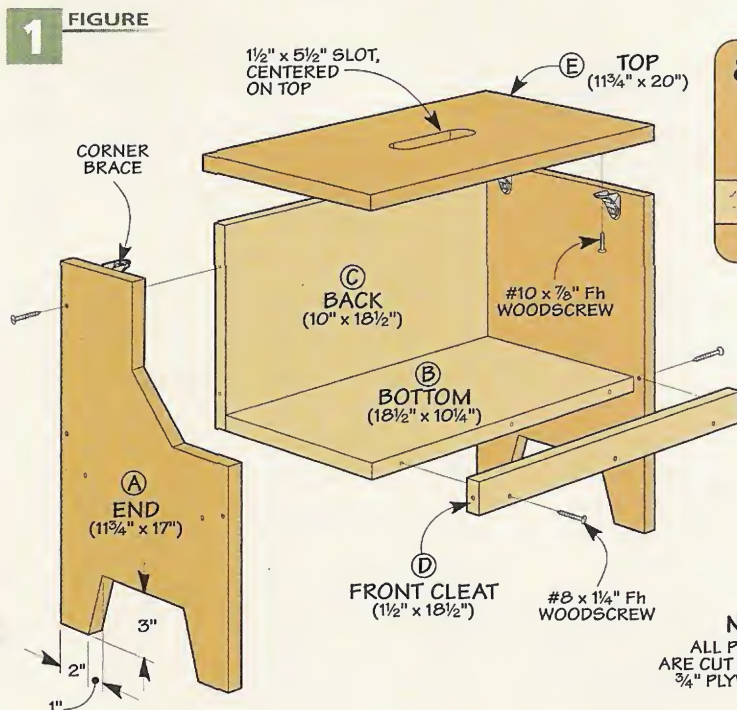

**CUTTING DIAGRAM**  
(3/4" - 48" x 48")

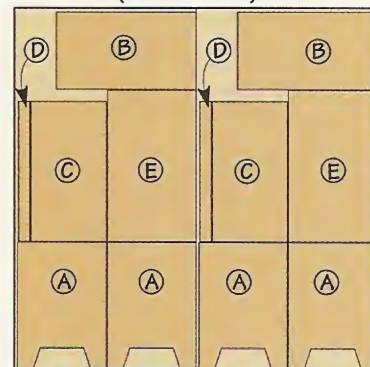

**NOTE:**  
ALL PIECES  
ARE CUT FROM  
3/4" PLYWOOD



# Folding Sawhorse

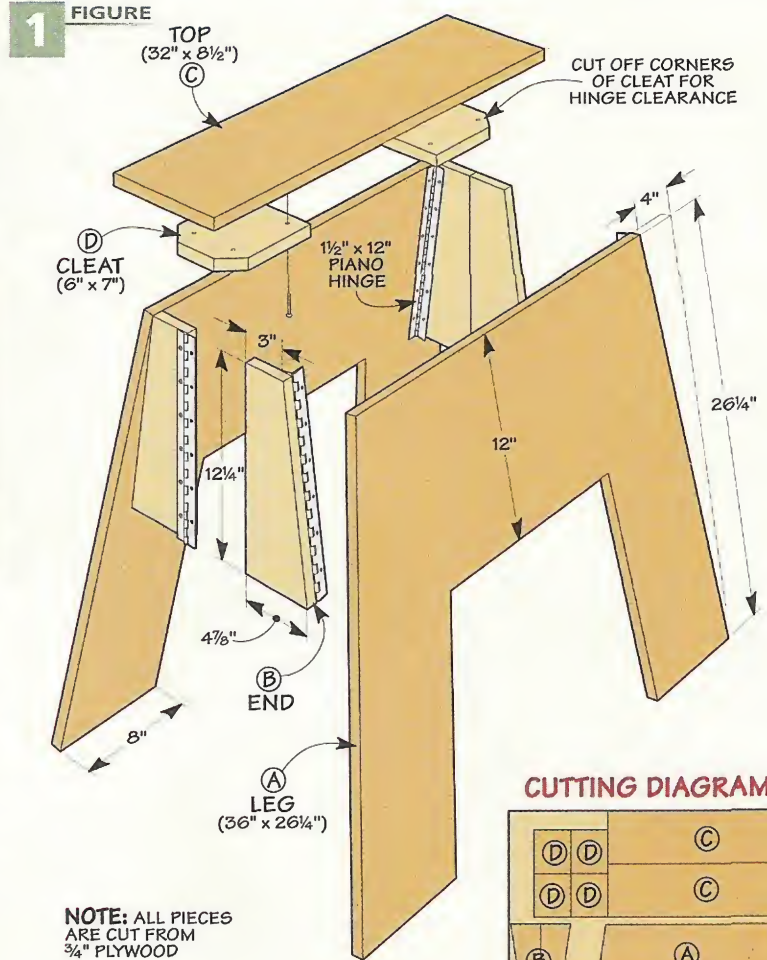

## CUTTING DIAGRAM

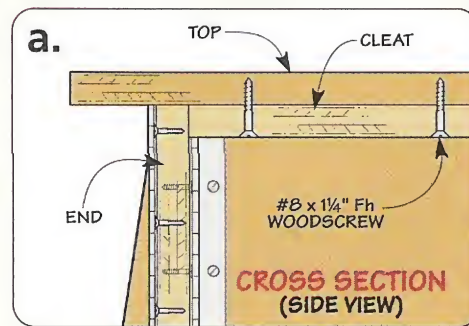
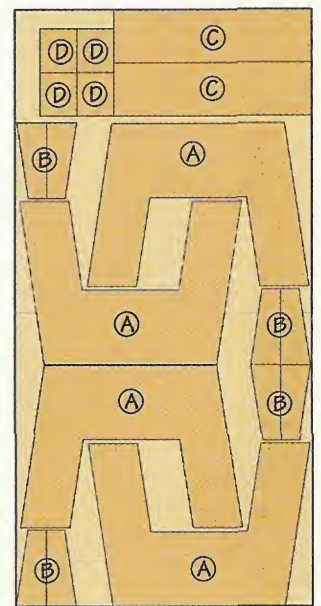

Sawhorses are a necessity in just about any shop. But these sawhorses are a little different in that they fold up for storage. This makes it easy to carry them anywhere and they don't take up much room when they aren't being used. But don't let the folding design fool you — these sawhorses are plenty sturdy for just about any task.

**Legs** — Before you start cutting out the pieces for the sawhorses, it's a good idea to take a close look at the cutting diagram at right. In order to get all the pieces for two sawhorses out of a single sheet of plywood, you'll need to do some careful laying out before you start cutting. And because of the shape of the legs, you'll need to cut these pieces out to rough size with a jig saw and then sand the edges smooth. Or you can trim them with a router and a straightedge guide.

**Ends** — After you've cut the legs (A) to size, you can start making the ends. If you take a look at Figure 1, you'll see that each end is actually made up of two separate pieces that are hinged in the middle, as well as to the legs. This is what allows the sawhorse to fold up.

After cutting out all the ends (B) they can be attached to the legs with piano hinges. (You'll need to

cut the hinges to length first.) It's a lot easier to attach each half of the end to a leg of the sawhorse first. Then the two halves are connected with another piano hinge.

**Top** — The top of the sawhorse is nothing more than a narrow, rectangular piece of plywood. The top (C) rests on the legs of the sawhorse —

it isn't permanently attached. But to help lock the top in place, a couple of cleats (D) are screwed directly to the underside of the top.

To use the sawhorse, simply open it up by pulling the legs apart and folding out the ends. Then set the top in place so the cleats fit securely between the legs.



▲ **Piano Hinge.** Also known as "continuous" hinges, piano hinges are used to attach the ends to the legs of the sawhorse.



# Cut-Off Bin



Dealing with short cut-off pieces of lumber is a problem that just about every woodworker has to face. No matter how neat you try to stack the cutoffs, it doesn't take long for a small pile to turn into a mountain. And this makes it almost impossible to sort through the cutoffs to find a piece that you can use.

Which is exactly why you need a storage bin like the one you see here. It's fairly small, so it doesn't take up much space. But it holds a lot of cutoffs. And dividers inside the bin allow you to sort the cut-offs, making it easier to find that one piece that you're looking for.

**Construction** - To build the cut-off bin, start by cutting the *front* (A), *back* (B), and *bottom* (C) to size (see the cutting diagram below). After cutting out these pieces, you can glue and screw them together. The bottom is trapped between the front and back to create a U-shaped assembly. But when you're doing this, make sure that the ends of the pieces remain flush.

**Dividers** - The next step is to add the *dividers* (D). These three pieces are all identical. They are cut to fit in between the front and back of the bin. After cutting the pieces to size and cutting the taper on the front edge of each piece, the two end dividers can be glued and screwed in place so that they are flush with the ends of the front, back, and bottom of the bin. The center divider separates the space inside the bin into two equal sections. This divider is centered between the two ends and then glued and screwed in place.

**Interior Dividers** - The last pieces to make are the two interior dividers (E). These pieces help to separate long and short cutoffs by dividing the bin into smaller compartments. The interior dividers are centered between the front and back of the bin. After cutting them to size, they're attached with corner braces (Figure 1a).

Most of the time, this cut-off bin will probably just sit in a corner of your shop. But you may want to

move it occasionally to clean behind it. The only problem is that once it's loaded up with lumber, moving it is no simple task. So to make things easier, I added some casters to the bottom. (I use two fixed casters and two swivel casters.) As you can see in Figure 1b, the casters are just screwed in place near the corners.



▲ Casters. To make the cut-off bin easier to move around, I added casters to the bottom.

1 FIGURE

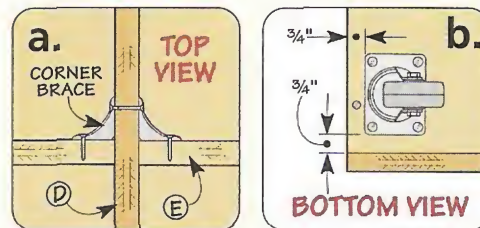
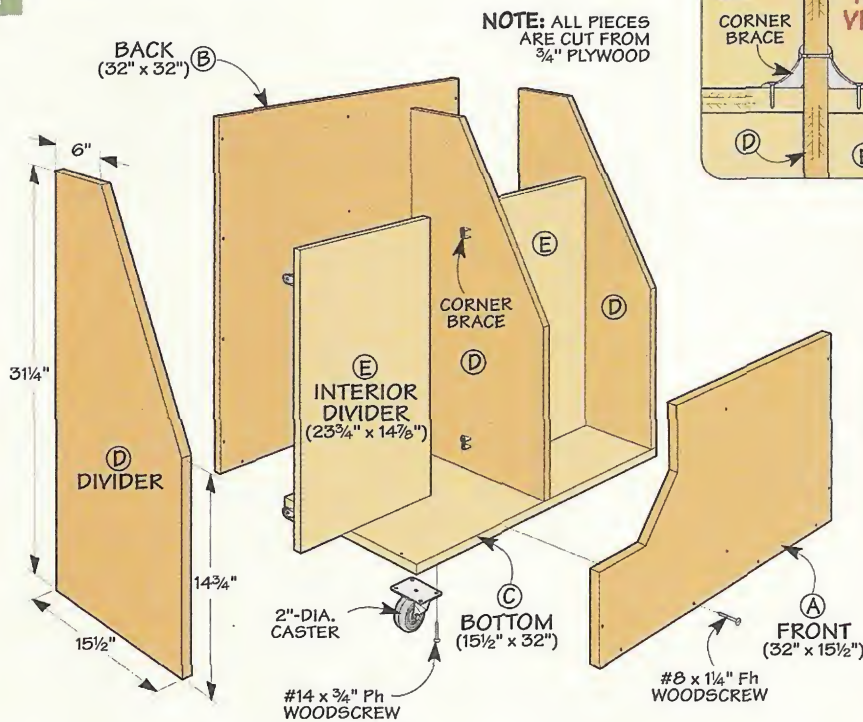

CUTTING DIAGRAM

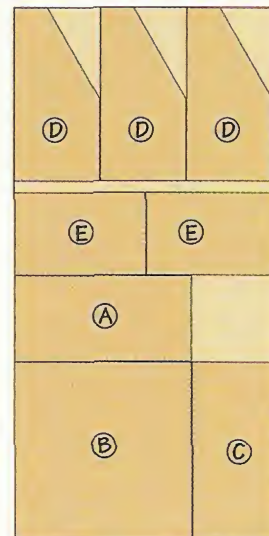



# Workbench

This workbench is just the right size for working on small projects. It can be set against the back wall of the garage without taking up too much space. And it has some storage room below the top for your tools. Even if you already have a full-size workbench in your shop, this bench makes a great “backup.”

**Joinery** – Like the other plywood projects, there isn’t any complicated joinery on this bench. It’s put together with screws and butt joints. But the trick is to assemble everything in a specific order and cut the parts to fit as you go along.

I started by cutting out the *ends* (A) and *back* (B) of the bench (Figure 1). Then I used a jig saw to cut away the waste and create the “feet” on the bottom of the two ends. I also drilled some shelf pin holes in the right-hand end piece.



▲ **Shelf Pins.** The adjustable shelf is supported by spoon-style shelf pins like the ones shown here.

After screwing the ends to the back, you can cut the *fixed shelf* (C) to fit in between the ends. Once you’ve positioned this piece between the ends, you can screw it in place.

**Top** – The *top* (D) is cut to size and attached to the ends with

corner braces (Figure 1a). Then you can cut the *divider* (E) to fit in between the top and the fixed shelf. Before attaching the divider, however, you’ll want to drill some shelf pin holes in the end of the bench. Then you can screw the divider to the fixed shelf and attach it to the top of the bench with a couple of corner braces.

Finally, I cut an *adjustable shelf* (F) to fit in the space between the divider and the end of the bench.

1 FIGURE

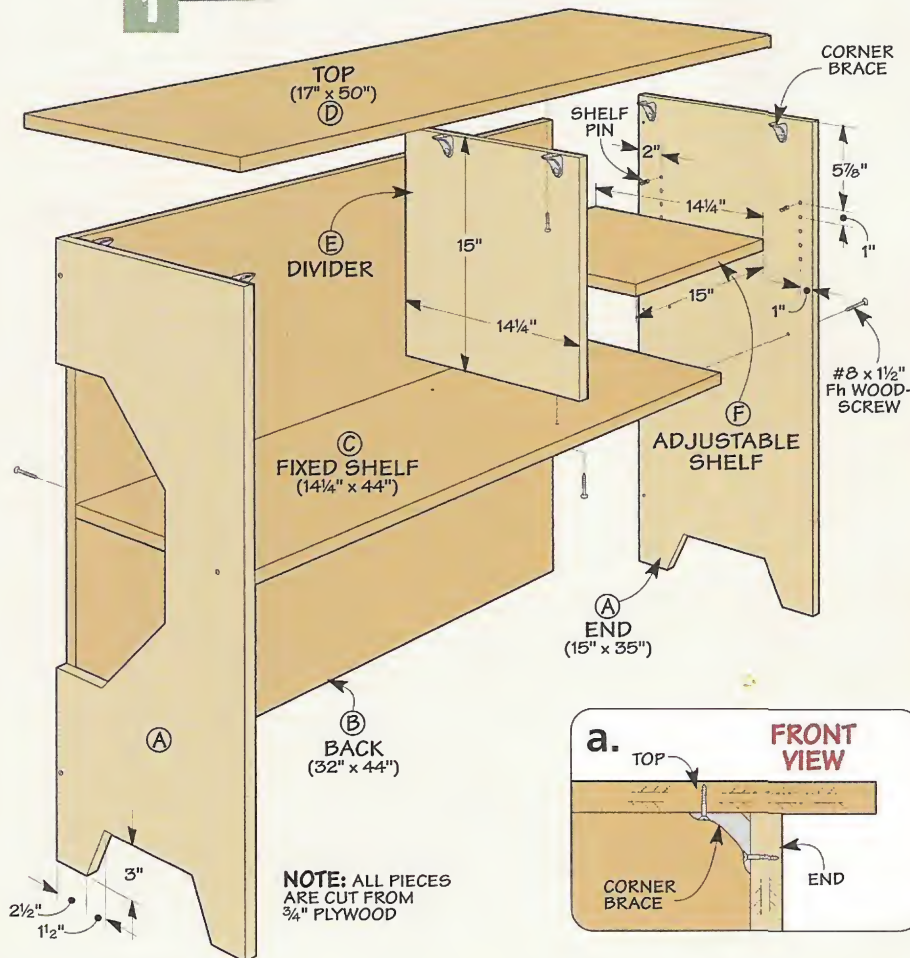

## CUTTING DIAGRAM

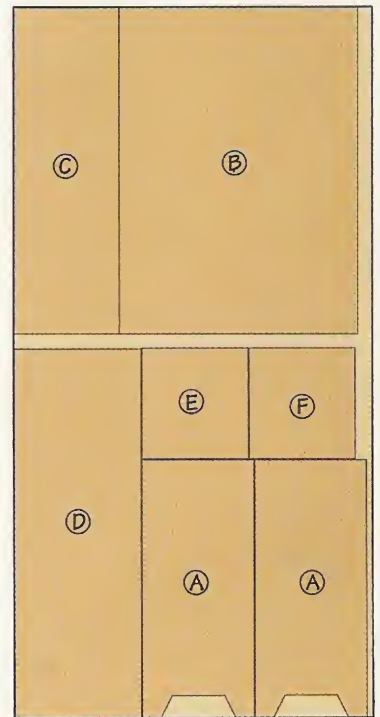



# Wall Cabinet

The last project I made was the wall cabinet that you see in the photo at right. Actually, this project is two cabinets — one with a door and one without. You can stack them or hang them on the wall side by side.

**Cases** — The cases of the two wall cabinets are identical except for their depth. One of the cabinets is  $\frac{3}{4}$ " shallower than the other one to allow for the thickness of the door.

You can start by cutting all the *sides* (A, B, C), *tops* and *bottoms* (D, E), and *backs* (F) to size, as shown in Figure 1 below. When it comes to cutting the sides, you'll notice that the cabinet with the door has one side that is  $\frac{3}{16}$ " narrower than the other. This is to allow for the door hinge that will be added later.

The next step is to drill some holes in the sides for the shelf pins that will be used to support the

shelves. I did this on the drill press. After you've finished drilling all the shelf pin holes, you can assemble the two cases. The sides, top, and bottom are all wrapped around the back panels and then glued and screwed together.

With the cases assembled, you can cut some adjustable *shelves* (G, H) to fit inside them. There are three shelves for the open cabinet and two for the cabinet with the door.

**Door** — At this point, the open cabinet is done. To complete the other cabinet, all you need is a door. The *door* (I) is just a piece of plywood cut to fit over the front of the case. It's attached with a piano hinge. Then to help keep the door closed, I added a couple of magnetic catches — one at the top of the cabinet and one at the bottom. Finally, I mounted a handle to the front of the door. 

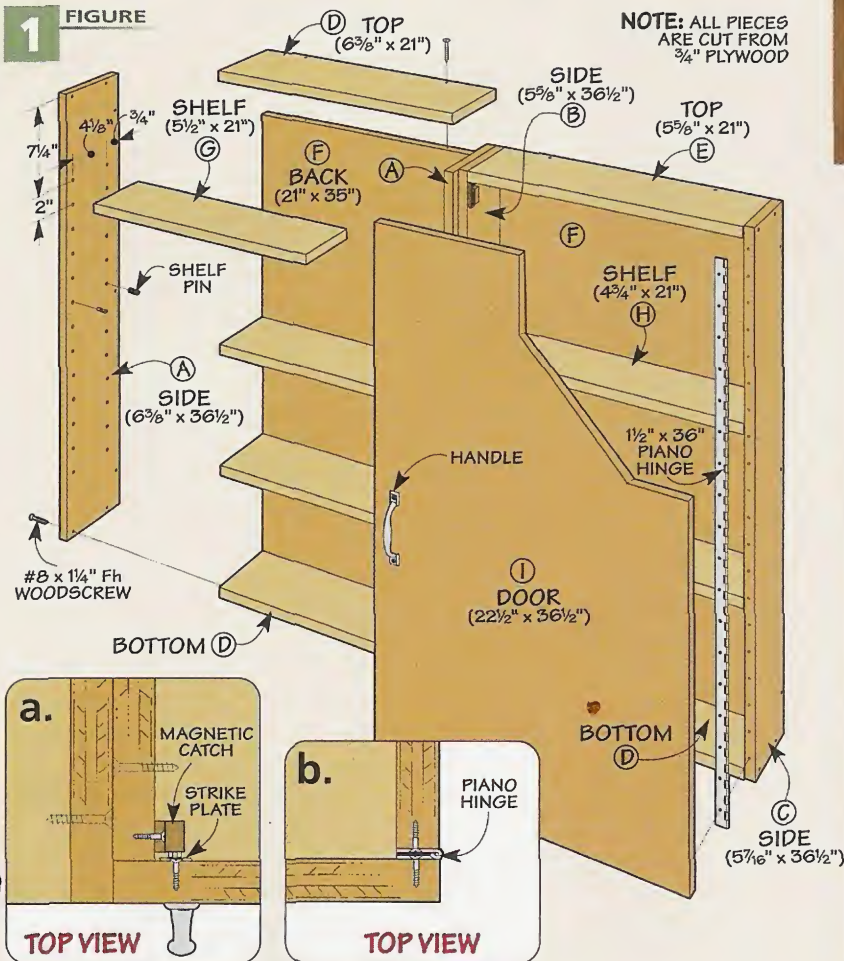

**CUTTING DIAGRAM**

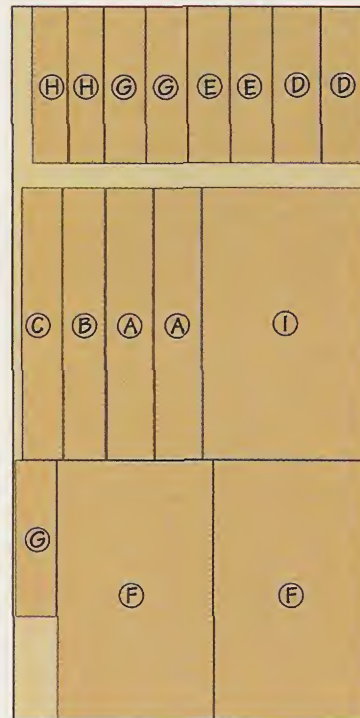

**▲ Door Hardware.** A window sash pull makes a low-cost, yet practical door handle. And a magnetic catch ensures that the door stays shut until you're ready to open it.



# Veritas Low-Angle Block Plane



One of the most versatile tools I have in my shop is a block plane. I keep it handy in my apron all the time. This way, I can quickly smooth edging flush with a panel, plane a clean chamfer along the corner of a workpiece, remove saw and mill marks from an edge, or easily trim some end grain to get a workpiece to fit just right.

If you've never had a block plane, or if you're thinking about

getting a new one, the *Veritas* low-angle block plane, shown in the photos and drawing above, is worth a look. I recently gave it a workout and was glad I did.

**A Design Difference** – Sure, you still get the adjustable mouth and the low blade angle typical of many block planes. But *Veritas* has made a few improvements.

One of the first changes was in the body of the plane — the sides are shaped differently. They're not only higher, but they're a little wider.

After using it for a while, I can see the advantages. For starters, each side provided solid support when I was using the plane with a shooting board, like you see in the inset photo at left. It felt solid and stable, unlike some block planes I've used.

Another advantage with the sides of the plane — no matter how I held the plane, I was able to find a comfortable grip. That's because my fingers nestled right into the indents machined into each side.

Many block planes need a “tune up” before you can use them. But that isn't the case with the *Veritas*. The machining and casting are top quality. The sides are perfectly square to the sole, which is very important for shooting, as I mentioned earlier. Plus, I didn't have to take any time to flatten the sole.

Speaking of the casting, *Veritas* uses a slightly different material to make the body of the plane — *ductile iron*. That's really just a fancy name for iron that's stronger and more forgiving of an accidental

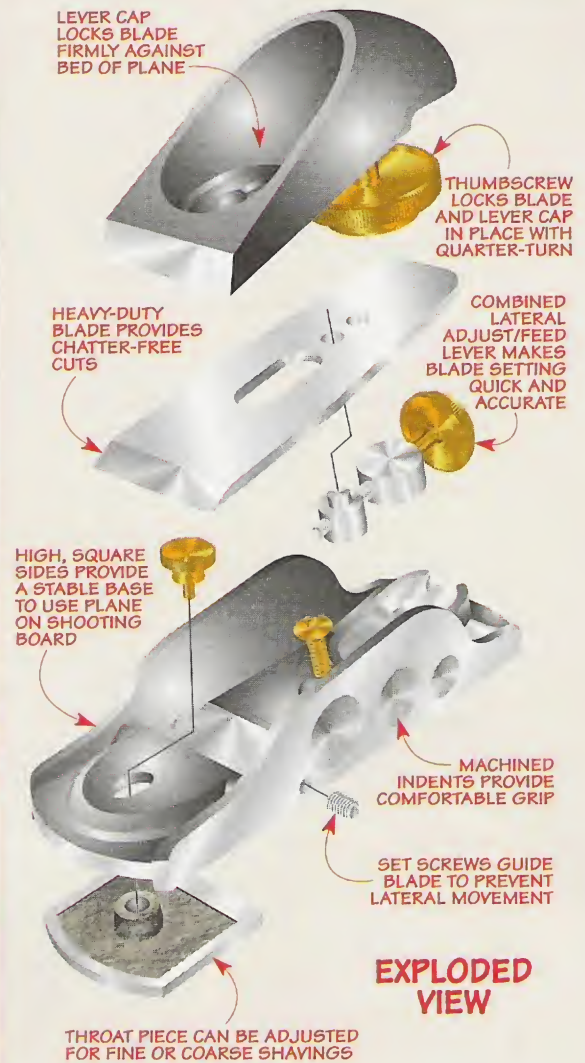



drop that might crack the casting on a typical block plane. Plus, it just feels downright substantial in my hand when I'm planing.

**Adjusting the Blade** – On most block planes, adjusting the blade can be a hassle. You have to advance the blade with one knob and control the skew (angle) of the blade with a separate lever (if it has one at all).

*Veritas* combined these two controls in a single lateral adjust/feed lever (see drawing on opposite page). As I turned the knob to adjust the depth of cut, I was able to “tweak” the skew of the blade by pivoting the same control.

Once I have a blade set, I always worried about it moving laterally during a cut or when I loosened the

lever cap to make a depth adjustment. *Veritas* added a nice feature to prevent this that you won't find on other block planes — guides.

These “guides” are nothing more than a pair of set screws installed in the sides of the plane. All I had to do was turn the screws in until they just touched the blade. This prevented any lateral movement unless I controlled it by moving the adjustment lever.

**Heavy-Duty Blade** – The improvements to this plane show up in the blade too. Like the body of the plane, the blade is also made from a different material than typical blades. *Veritas* uses a material called A2 tool steel.

This material is tougher than the steel used in most blades. This

means the blade will stay sharper longer and resist chipping. And since the blade is a 1/8" thick (almost half again as thick as a typical block plane blade), it practically eliminates any annoying chatter as you plane.

**Is It Worth It?** – A typical block plane costs \$40 - \$50. As you might expect, the *Veritas* costs a little more (\$89). But considering the features it has and the quality that's built in, I think the price is quite a bargain.

**Accessories** – One last thing. The *Veritas* has a couple other things going for it — accessories. They're easy to use and install, and they make the plane more versatile. To read more about them, take a look at the box below. ▲

<h3>Source</h3>
<p>Lee Valley  <a href="http://leevalley.com">leevalley.com</a>                  800-871-8158</p>

## Expanding the Capability

Accessories aren't something you usually associate with a block plane. But *Veritas* offers two that you might want to consider.

**Chamfer Guide** – The first accessory solves one of those problems you don't think about too much until you actually start doing it. And that's accurately cutting a chamfer along the edge of a workpiece. It can be quite a challenge to keep the block plane angled at exactly 45° as you slide the plane along the edge.

Accomplishing this with the *Veritas* block plane is a snap. Simply remove the adjustable throat piece and install the chamfer guide (see photo at right).

The guide is adjustable (see inset photo below), so you can easily plane chamfers up to 1/2" wide.

**Smoothing Kit** – The other accessory has two parts — a tall, wood knob that replaces the brass front knob, and a second knob that screws to the rear of the plane. These knobs make it easy to use the *Veritas* block plane as a low-angle smoothing plane.

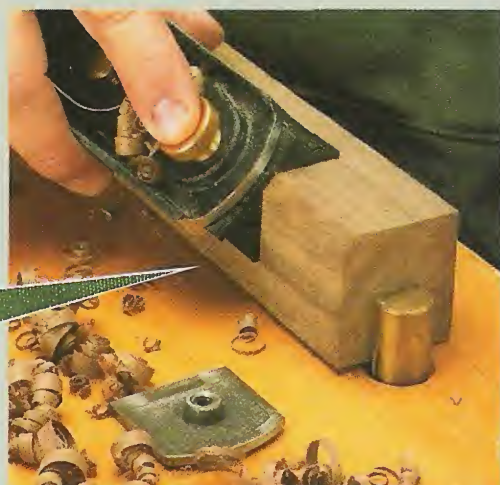

▲ **Chamfer Guide.** The guide replaces the adjustable throat piece on the plane. Adjusting the size of the chamfer is a simple matter of moving one edge of the guide (left photo).

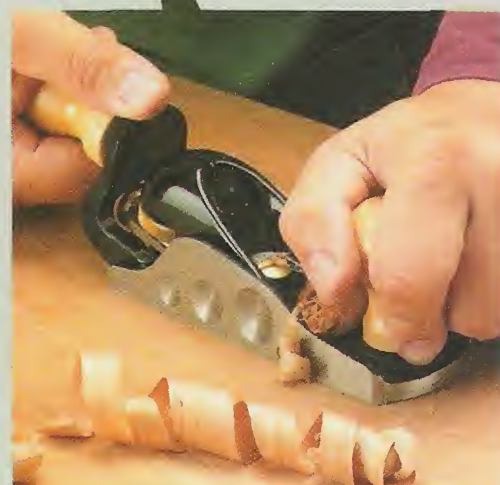

▲ **Smoothing Plane Kit.** To turn the block plane into a versatile, low-angle smoothing plane, you can add a pair of knobs that provide a solid grip for bearing down on the workpiece.



# When Good Glues Go Bad

**W**oodworkers tend to be a pretty thrifty group. Most of us don't like to throw anything away, whether it's a scrap of wood, a worn-out piece of sandpaper, or an old, half-empty bottle of glue.

But unlike some other supplies, glue doesn't keep indefinitely. And if you use glue that is too old, you're risking glue joint failure down the road.

So, how long is it safe to keep a bottle of wood glue around the shop? Most manufacturers will tell you that yellow glue has a shelf life of two years — from the time it is manufactured. But there's the rub. When you buy a bottle of glue from the store, it's hard to know how long it may have been sitting on the shelf or in a warehouse.

**Date Code** — Fortunately, most of the glue manufacturers print a code on their glue bottles that, once deciphered, will tell you when the glue was manufactured. For more on these codes, see the box below.



▲ **Fresh Glue.** Glue from a brand new bottle is smooth and slick, and spreads out evenly with your finger.

But the two year rule is really just a minimum. Actually, the glue can last as much as three or four years. It all has to do with how the glue ages.

## WHAT HAPPENS TO GLUE

Yellow glue is made up of individual particles. These particles each have a coating that prevents them from sticking to one another inside the bottle. Exposure to air, heat, mold, and bacteria all cause the coating to deteriorate. When it does, the glue particles start to adhere to each other and the glue gets thick and stringy, like you see in the lower right photo above.

One way to tell if the glue is still good is to spread some out on a piece



▲ **Old Glue.** Glue that is past its prime turns thick and stringy, and doesn't spread out smoothly.

of wood with your finger. If the glue spreads out smoothly, it's okay. But if it balls up behind your finger as you try to spread it, it's beyond its useful life.

## STORAGE

The amount of time it takes before the glue starts to go bad depends a great deal on how it's stored. The most important thing is to remember to close the cap after using the glue to prevent air from entering the bottle. Nothing will cut short the life of a bottle of glue faster than allowing it to dry out. And if you buy glue in gallon jugs, it's a good idea to immediately separate it into smaller containers. As you use the glue, there'll be a smaller volume of air in the bottle than if you had left it in the gallon jug.

Ideally, yellow glue should be stored in a cool, dry environment (55°-65°F). Hot, humid conditions encourage the growth of bacteria that breaks down the glue. And despite what you may have heard, freezing will not ruin glue. (The glue may thicken, but it will return to its normal state if you stir it up a bit.)

One last thought: When you consider how inexpensive glue is, it's just not worth taking a chance on ruining a project by using a suspect bottle of glue. So I use the same rule with glue as I do with leftovers in the fridge — "When in doubt, throw it out." 🗑️

## Cracking the Code



Most glue manufacturers print a production code on the back of each glue bottle to keep track of when and where the glue was made. But each manufacturer uses a slightly different coding system.

**Titebond** — (See photo at left.) The first character indicates the year (2 = 2002, 3 = 2003). The second character indicates the month (A = January, B = February, etc.). (The letter "I" is skipped to avoid confusion with the number 1.)

**LocTite** — The first number denotes the year and the next three numbers the day of the year. For example, a code of 2175 means the glue was made on the 175th day of 2002.

**Elmer's** — The first letter is the year (H = 2002, I = 2003, etc.). The following two numbers are the day of the month. This is followed by a letter indicating the month (A = January, B = February, etc.)



# Sources

## Router Table Hardware Kits

■ The stow-away router table requires a bit of hardware, some of which you probably won't find at your local hardware store or home center.

To save you the hassle of tracking everything down, *ShopNotes Project Supplies* has put together a hardware kit that contains everything you'll need.

The kit has the T-track, dual track, guard, featherboard, dust hood, toggle clamps, knobs, and all the miscellaneous hardware.

The only thing you'll have to provide is the router, plywood, hardwood, and plastic laminate. **Stow-Away Router Table Hardware Kit**  
6871-100 . . . . \$99.95

You can also order just the T-track and dual track. **T-Track and Dual Track Hardware Kit**  
6871-125 . . . . \$39.95

To order either kit, see the box below.

If you choose not to get either kit, we've listed several sources for some of the hard-to-find hardware in the margin at right.

## Online Extras

■ If you don't have access to the internet, we'd be happy to mail a copy of the Online Extras to you. Just specify which one you'd like and send a self-addressed, stamped #10 envelope to:

ShopNotes No. 71  
Online Extras  
P. O. Box 842  
Des Moines, IA 50304

## Benchtop Vise Hardware

■ Most of the hardware required for the benchtop vise shown on page 14 can be found at your local hardware store or home center. But there are a few items you'll have to order through the mail.

**Handle** – The handle we used for the vise came from *Reid Tool*. The part number is ASC-7T. Their phone number and website are listed in the margin.

**Magnets** – To hold the auxiliary vise faces in place we turned to *Lee*

*Valley*. The part number for the 1/2"-dia. rare-earth magnets we used is 99K31.03. Be sure to get the matching magnet cups (99K32.53) and washers (99K32.63) to complete the installation.

**Leather** – Finally, you'll need a small amount of leather. We got ours at a local leather shop.

If you can't find any locally, give *Tandy Leather* a call at 1-888-890-1611 or check out their website at [www.tandy-leather.com](http://www.tandy-leather.com).

## Plywood Bits & Blades

■ If you work with plywood a lot, you may want to consider adding some specialty saw blades and router bits that will help make clean, chipout-free cuts.

**Saw Blades** – Whether you're cutting plywood down to size with a circular saw, or cleaning up the edges on your table saw, there's a saw blade that will help.

For circular saws, look for a steel plywood blade at your local hardware store or home center. They're inex-

pensive and do a great job. And for table saws, a triple chip grind blade with a negative hook angle fits the bill. We use a *Freud* LU97R blade in our shop. But other sources have plywood saw blades (see margin).

**Router Bits** – To make a chipout-free cut on both faces of a sheet of plywood, a compression bit is what you need. *Freud* makes single (77-106) and double (77-206) flute versions. Sources for these bits are listed in the margin. 

## MAIL ORDER SOURCES

*Similar project supplies may be ordered from the following companies:*

- Rockler**  
800-279-4441  
[www.rockler.com](http://www.rockler.com)  
*Knobs, Plywood Saw Blades, Toggle Clamps*
- Reid Tool**  
800-253-0421  
[www.reidtool.com](http://www.reidtool.com)  
*Handle, Knobs, Toggle Clamps*
- McFeelys**  
800-443-7937  
[www.mcfeelys.com](http://www.mcfeelys.com)  
*Knobs, Plywood Saw Blades, Toggle Clamps*
- Freud**  
800-472-7307  
[www.freudtools.com](http://www.freudtools.com)  
*Compression Bits, Plywood Saw Blades*
- Lee Valley**  
800-871-8158  
[www.leevalley.com](http://www.leevalley.com)  
*Low-Angle Block Plane & Accessories, Rare-Earth Magnets, Cups, & Washers*
- Woodsmith Store**  
800-835-5084  
*Knobs, Plywood Saw Blades, Toggle Clamps*
- Eagle America**  
800-872-2511  
[www.eagle-america.com](http://www.eagle-america.com)  
*Compression Bits, Plywood Saw Blades*

## SHOPNOTES PROJECT SUPPLIES

To order back issues or a hardware kit from *ShopNotes Project Supplies*, please use our toll-free order line, see below. It's open Monday through Friday, from 8 AM to 5 PM Central Time. Before calling, please have your VISA, MasterCard, Discover, or American Express card ready.

If you would prefer to mail in an order, please call the toll-free phone number below for more information concerning shipping charges as well as any applicable sales tax.

**1-800-347-5105**

## ShopNotes *on the web*

- "Online Extras" - Plans, Patterns, & More
- Over 100 Woodworking Tips Online
- Visit Our Woodworking Shop Tours Gallery
- Project Plans You Can Download
- Catalog of Project Kits, Tools, Jigs, & Plans
- Forums for Woodworking, Tools, & Classifieds
- Links to Other Woodworking Sites
- Order *ShopNotes* & *Woodsmith* Back Issues

[www.shopnotes.com](http://www.shopnotes.com)

### Online Customer Service

Click on Subscriber Services at [www.shopnotes.com](http://www.shopnotes.com)

- Access your account status
- Change your mailing or email address
- Pay your bill
- Renew your subscription
- Tell us if you've missed an issue
- Find out if your payment has been received



## Scenes from the Shop

*This shop-made benchtop vise holds your work at a convenient height and gives you access to all sides of the workpiece. And the optional jaw faces will handle*

*a variety of clamping challenges. Plus, there's a cam-activated release so you can quickly open and close the vise. Step-by-step plans begin on page 14.*





# Adding a Switched Outlet

*With just a handful of hardware and an hour of work, you can add a switched outlet to any power tool.*



**T**urning a power tool on and off is easy right? Just flip the switch. Unfortunately, it's not always convenient or even easy to access a switch quickly — especially on a hand-held router that's been mounted in a table.

I found this out on the Stow-Away Router Table in Issue No. 71. To solve this problem, I added a switched outlet to the side of the table. With a switched outlet that's positioned for easy access, you won't have to worry about finding

the on/off switch — especially if you need to get to it in a hurry.

**Wire the Switch** — At first glance, you might think that adding a switched outlet isn't a task for a woodworker. But it's not that difficult. All you need to do is run a length of electrical cord (with a plug wired on one end) between a wall outlet and a switch/receptacle, like you see in the drawing below.

The hardware you'll need to do this is detailed in the Electrical Hardware box at the lower right.

Note: The switched outlet I purchased also came with its own set of wiring instructions.

Once you've wired the switched outlet, just plug the power cord from the tool into the receptacle and you're all set. Note: You'll need to leave the switch on the power tool in the "on" position.

One last thing. If you're at all uncomfortable working with electricity, you may want to locate a qualified electrician to wire the switch for you. ⚡

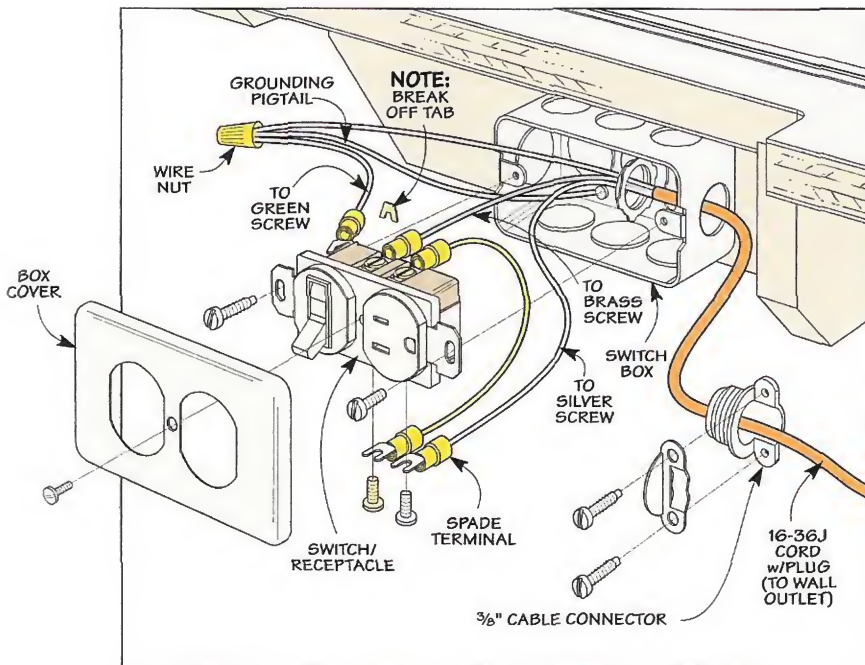

## Electrical Hardware

- (1) 15 Amp., 120 Volt Switch/Receptacle
- (1) Switch Box
- (6) No. 8 Spade Terminals (16/14 ga.)
- (2) Grounding Pigtails (12 ga.)
- (1) 3/8" Cable Connector
- (1) Wire Nut Connector (Yellow)
- (2) #8 x 5/8" Ph Sheet Metal Screws
- (1) Duplex Box Cover
- (1) 15 Amp., 125 Volt Plug (Grounded)
- (1) 16-35J Electric Cord (Variable Length)



# Quick-Release Rear Jaw



## Correction: ShopNotes 71

The materials list on page 15 and Figure 7 on page 18 show the rear jaw face as 8 1/2" long.

The correct dimension for this part is 9" long.

*Adjust the rear jaw of the vise quickly and easily with this simple option.*

**T**his quick-release allows you to rapidly open or close the jaws of the benchtop vise in Issue No. 71. It works just like the quick-release mechanism on a manufactured bench vise. Instead of turning the handle of the vise, all you have to do is flip a lever and slide the rear jaw to where you want it. Then flip the lever back to lock the jaw in position.

An added plus to this quick-release feature is that the main parts of the vise — the base and front and rear jaws — remain basically the same. The only thing that changes are the parts inside the rear jaw. (You will also have to add a bronze bushing to the face of the rear jaw, as shown in Figures 1 and 1a.)

As you can see in Figure 1, the secret behind the quick release is a "half nut." A cam raises and lowers this half nut to engage or disengage the threads of the vise.

The first step in making the quick release is to make the half nut assembly. Start by cutting a coupling nut lengthwise into two pieces, as

shown in Figure 1. This can be done with a hacksaw. (Note that you want to make the cut slightly off center.) Save the smaller "half" and discard the larger one.

The half nut is sandwiched between two blocks of wood. To make these blocks, I first cut a groove down the center of a hardwood blank. Then I cut two blocks from the blank. After epoxying the half nut into the groove in one of the

blocks, I glued the two blocks together (Figure 3).

Like in the standard version of the benchtop vise, a couple of retaining strips are glued to the inside walls of the rear jaw assembly to hold the half nut assembly in place. Figure 1 shows you the position of these retaining strips.

**Rails** — The rails of the quick release version of the vise aren't really any different than those on the

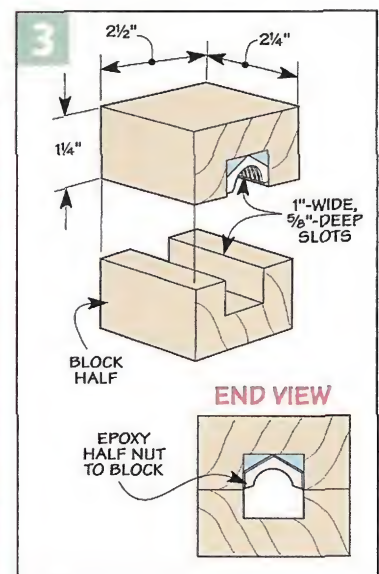
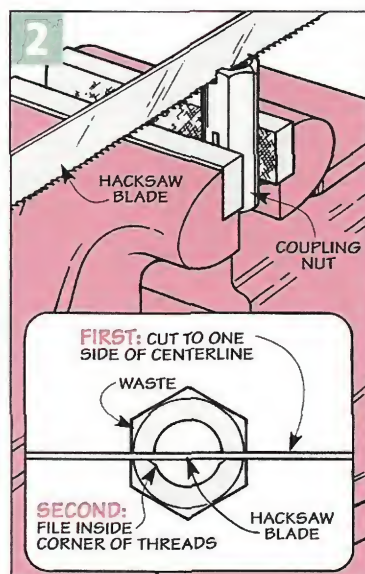
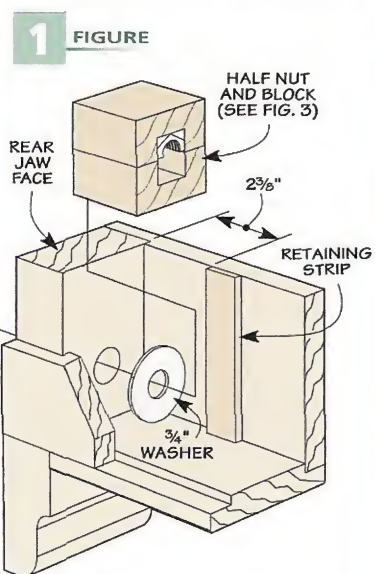
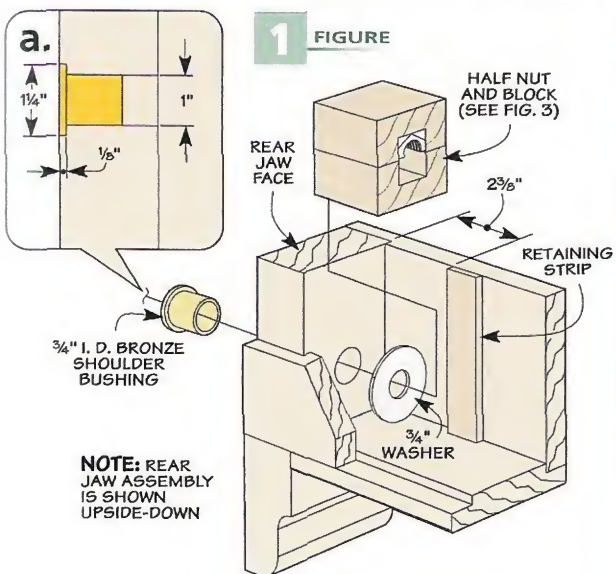



standard version. The only modification you will have to make is to cut a notch in the right-hand rail for the cam lever that will be added later. I did this by simply drilling a hole in the rail and then cutting away the waste and filing the edges smooth.

**Cam Assembly** – To raise and lower the half nut, I used a cam mechanism, as you can see in Figure 5. This is nothing more than a couple of wood disks that are mounted on a shaft that passes through the body of the rear jaw. A lever on the end of the shaft allows you to tighten or loosen the cams. And a spring helps to hold the cams in place.

To make the cams, I just used a hole saw to create two round disks of wood (see detail in Figure 5). Then I drilled an off-center hole in each disk for a wood shaft.

To mount the cams inside the rear jaw, you'll need to make a shaft. This

is nothing more than a short length of 3/4"-dia. dowel. A couple of holes are drilled in the sides of the rear jaw to hold the shaft. Then the shaft can be slipped through the rear jaw and the cams. The cams are secured to the shaft with a couple of screws (Figure 5b). Just make sure when you are doing this that you line the cams up so that they both have the same orientation (see Figures 5 and 5a).

**Spring** – With the cams and shaft in place, you can add the spring. To do this, start by drilling a small pilot hole in the shaft and thread in a screw eye. Next, drill a hole in each side of the rear jaw for a steel pin. This pin is used to anchor one end of the spring. It's glued in place with epoxy. The other end of the spring is hooked over the screw eye on the shaft of the cam assembly.

**Handle** – The last step is to add the handle. I made the handle out

of 1/2"-thick hardwood stock. After drilling the hole in the end of the handle blank, it can be cut and sanded to shape. Then the handle is attached to the end of the shaft with a single woodscrew (Figure 5c). The key here is to position the handle so that the half nut is engaged when the handle is in the forward position. This way, pushing the handle back will disengage the half nut and allow you to slide the jaw to the desired position.

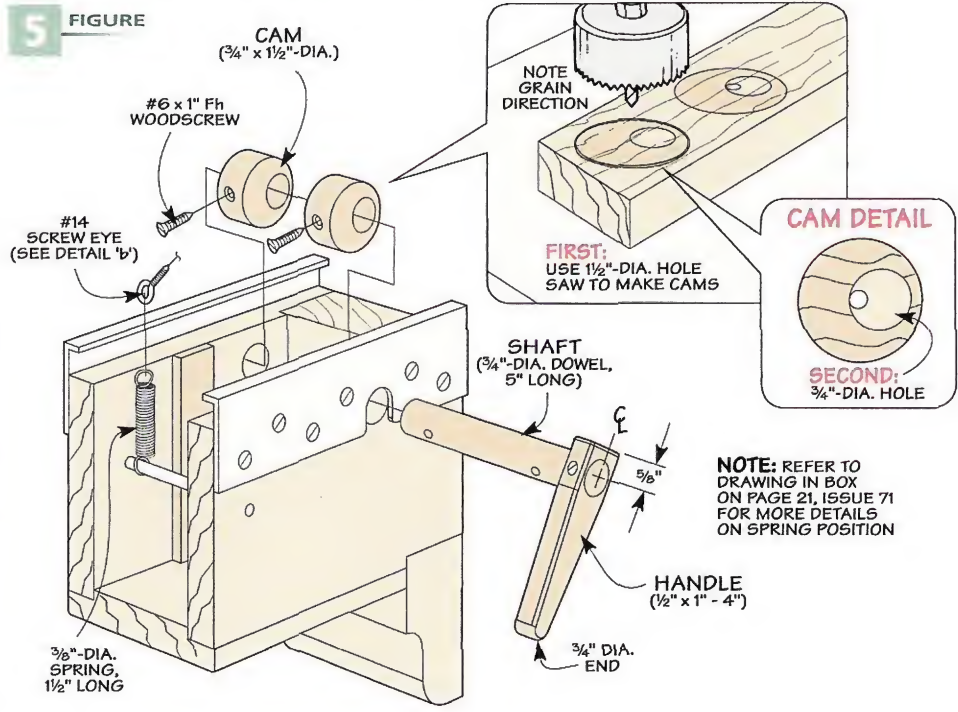
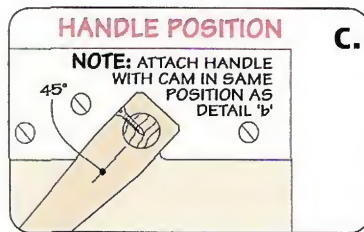
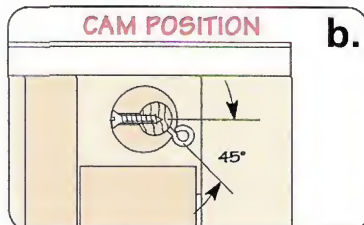
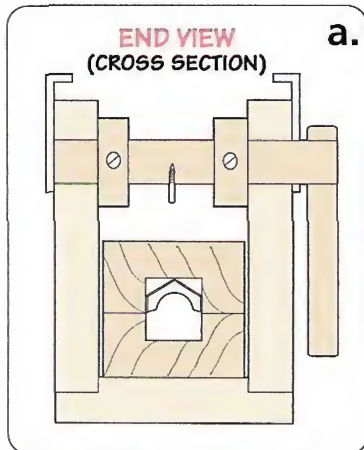
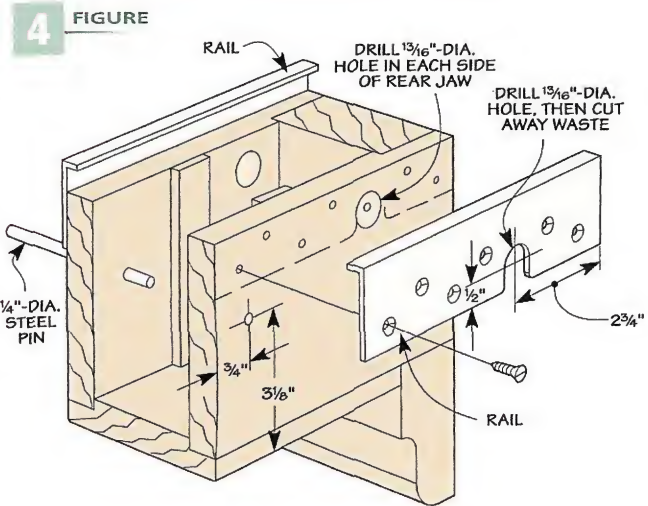



# Correction:

## *ShopNotes 71*

The materials list on page 15 and Figure 7 on page 18 show the rear jaw face as  $8\frac{1}{2}$ " long.

The correct dimension for this part is 9" long.