

SPECIAL
Small Shop Solutions

A QUICK WAY TO RESCUE RUSTY TOOLS

ShopNotes®

Vol. 12 www.ShopNotes.com Issue 72

**SAVE SPACE,
TIME & MONEY:**

All New
Drill Press
Belt Sander
Modular
Table Saw
Outfeed
System

Build The Ultimate
**FOLD-DOWN
WORKSTATION**





ShopNotes

Issue 72

Nov./Dec. 2003

PUBLISHER Donald B. Peschke

EDITOR Terry J. Strohman

ASSOCIATE EDITORS Bryan Nelson
Vincent Ancona

CONTRIBUTING EDITOR Phil Huber

ART DIRECTOR Cary Christensen

SENIOR ILLUSTRATORS Roger Reiland
Mark Higdon

CREATIVE RESOURCES

Creative Director: Ted Kralicek • *Sr. Project Designers:* Ken Munkel, Kent Welsh, Ryan Mümick, Chris Fitch • *Shop Craftsmen:* Steve Curtis, Steve Johnson • *Sr. Photographer:* Crayola England

SPECIAL PUBLICATIONS

Corp. V.P.: Douglas L. Hicks • *Art Director:* Douglas A. Flint • *Sr. Graphic Designer:* Chris Glowacki • *Graphic Designer:* Jonathan Eike • *Sr. Editor:* Craig Ruegsegger • *Assoc. Editor:* Joel A. Hess

CIRCULATION

Circ. Oper. Director: Sandy Baum • *Circ. Marketing Dir.:* Wayne J. Klingbeil • *Strategic Business Analysts:* Kris Schlemmer, Paula M. DeMatteis • *Circ. Marketing Analyst:* Patrick Walsh • *Renewal Mgr.:* Paige Rogers • *Circ. Marketing Assoc.:* Christine Forret • *Circ. Fulfillment Mgr.:* Stephanie Forinash • *Sr. Graphic Designers:* Mark Hayes, Jr., Robin Friend

CORPORATE SERVICES

V.P. of Finance: Mary R. Scheve • *Controller:* Robin K. Hutchinson • *Sr. Acct.:* Laura J. Thomas • *Accts. Payable:* Mary J. Schultz • *Accts. Receivable:* Margo Petrus • *Prod. Dir.:* George Chmielarz • *Electronic Pub. Dir.:* Douglas M. Lidster • *System Admin.:* Cris Schwanebeck • *P.C. Maint. Tech.:* Robert D. Cook • *Pre-Press Image Specs.:* Troy Clark, Mimiette Johnson • *Assoc. Style Dir.:* Rebecca Cunningham • *New Media Mgr.:* Gordon C. Gaippe • *Multimedia Art Dir.:* Eugene Pedersen • *Web Server Admin.:* Carol Schoeppler • *Web Content Mgr.:* David Briggs • *Multi-media Designer:* Kara Blessing • *Research Coordinator:* Nicholas A. Jaeger • *Prof. Dev. Dir.:* Michal Stigel • *H. R. Asst.:* Kirsten Koele • *Office Mgr.:* Natalie Lonsdale • *Facilities Mgr.:* Kurt Johnson • *Admin. Asst./Recept.:* Jeanne Johnson • *Mail Room Clerk:* Lou Webber

WOODSMITH STORE

Operations Director: Bob Baker • *Customer Service Mgr.:* Jennie Enos • *Warehouse Supr.:* Nancy Johnson • *Buyer:* Linda Jones • *Admin. Asst.:* Nancy Downey • *Sr. Cust. Serv. Reps.:* Tammy Truckenbrod, Anna Cox, Deborah Rich, April Revell • *Cust. Serv. Reps.:* Valerie Jo Riley, Kim Harlan, Cheryl Jordan • *Warehouse:* Sylvia Carey, Larry Morrison, Niel Nardini • *Store Manager:* Dave Larson • *Merchandise Marketing Mgr.:* John Siberell • *Paint Dept. Mgr.:* James Hockins • *Asst. Mgr.:* Tim Thelen • *Store Sales Staff:* Gregory Kauzlarich, Mark Johnson, John Warren, Dave Fremming, Stephen Duncan, Brian Simmons, Mike McCauley • *Office Mgr.:* Vicki Edwards • *Admin. Asst.:* Tammy Kissler

ShopNotes® (ISSN 1062-9696) is published bimonthly (Jan., March, May, July, Sept., Nov.) by August Home Publishing, 2200 Grand, Des Moines, IA 50312.

ShopNotes® is a registered trademark of August Home Publishing © Copyright 2003 by August Home Publishing. All rights reserved. Subscriptions: Single copy: \$4.95. One year subscription (6 issues), \$27.95. Canada/International add \$10 per year, U.S. funds.

Canadian Subscriptions: Canada Post Agreement Number 40649740. Send change of address information and blocks of undeliverable copies to PO Box 1051, Fort Erie, ON L2A 6C7.

Periodicals Postage Paid at Des Moines, IA and at additional mailing offices.

Postmaster: Send change of address to ShopNotes, P.O. Box 37103, Boone, IA 50037-2103.

Subscription Questions? Write to: ShopNotes Customer Service, P.O. Box 842, Des Moines, IA 50304-9961. Or call 1-800-333-5854, 8:00 am to 5:00 pm, Central Time, weekdays. FAX 515-283-0447

Email: ShopNotes@shopnotes.com
Internet: http://www.shopnotes.com

PRINTED IN U.S.A.

EDITOR'S NOTE

Cutoffs

Okay, I admit it. I've always dreamed of having a large, spacious workshop with lots of room for benches, tools, and accessories.

But the reality for many woodworkers (myself included) is that shop space is a precious commodity. There just never seems to be enough.

So what do you do? Well, it seems to me the key is to make the best possible use of the space that you do have. So in this issue, we've put together three projects that will help get the most out of your shop space.

Workstation – For starters, there's the three-part, fold-down workstation shown on the front cover. It features a rock-solid workbench, a wall-mounted tool rack, and an overhead storage cabinet. It's made up of three parts. You can build one or all three — the choice is up to you.

The wall-hugging design of the workstation takes up a minimal amount of floor space. But when you need to get to work, all you have to do is lift the bench top, swing out the legs, and you're ready to go.

The second part of the station is a wall-mounted tool rack that lets you keep your favorite hand tools organized, visible, and within reach.

Finally, we added an upper cabinet that can hold everything else you need close at hand — from power tools and accessories to project hardware. It all starts on page 22.

Table Saw Outfeed System – Another project that makes the most of available space is the table saw outfeed system on page 16. It consists of individual, snap-together units. Grouped together, they make a solid outfeed table that doesn't take up much space. But you can also take the units apart and arrange them to offer support where you need it — like when you're ripping large sheets of plywood.

Belt Sander – The final project takes one tool and adds another function to it. If you already have a drill press, here's an inexpensive way to add a belt sander. It features an adjustable table, tracking control, and a miter slot. Check it out on page 6.

Terry

STATEMENT OF OWNERSHIP, MANAGEMENT, AND CIRCULATION (Required by 39 U.S.C. 3685)

1. Publication Title: ShopNotes. 2. Publication No.: 1062-9696. 3. Filing Date: September 16, 2003. 4. Issue Frequency: Bimonthly. 5. No. of issues published annually: 6 (six). 6. Annual subscription price: \$27.95. 7. Complete mailing address of known office of publication: 2200 Grand Avenue, Des Moines, (Polk County), Iowa 50312-5306. 8. Complete mailing address of the headquarters or general business offices of the publisher: 2200 Grand Avenue, Des Moines, (Polk County), Iowa 50312-5306. 9. Full names and complete mailing addresses of publisher, editor, and managing editor: Publisher: Donald B. Peschke, 2200 Grand Avenue, Des Moines, Iowa 50312; Editor: Terry Strohman, 2200 Grand Avenue, Des Moines, Iowa 50312. 10. Owner: August Home Publishing Company, 2200 Grand Avenue, Des Moines, Iowa 50312; Donald B. Peschke, 2200 Grand Avenue, Des Moines, Iowa 50312. 11. Known bondholders, mortgagees, and other security holders owning 1 percent or more of total amount of bonds, mortgages or other securities: None. 12. (Does not apply.) 13. Publication Title: ShopNotes. 14. Issue Date for Circulation Data Below: July/August 2003 (#70). 15. Extent and nature of circulation:

	Average no. copies each issue during preceding 12 months	Average no. copies of single issue published nearest to filing date
A. Total number of copies (net press run).....	217,352	203,474
B. Paid and/or requested circulation:		
1. Paid/Requested outside-county mail subscriptions stated on Form 3541.....	163,683	145,255
2. Paid in-county subscriptions.....	0	0
3. Sales through dealers and carriers, street vendors, counter sales, and other non-USPS paid distribution.....	21,509	23,838
4. Other classes mailed through the USPS.....	0	0
C. Total paid and/or requested circulation.....	185,192	169,093
D. Free distribution by mail, samples, complimentary, and other free copies:		
1. Outside-county as stated on Form 3541.....	103	80
2. In-county as stated on Form 3541.....	0	0
3. Other classes mailed through the USPS.....	0	0
E. Free distribution outside the mail (carriers or other means).....	0	0
F. Total free distribution.....	103	80
G. Total distribution.....	185,295	169,173
H. Copies not distributed.....	32,057	34,301
I. Total.....	217,352	203,474
J. Percentage Paid and/or requested circulation.....	99.94%	99.95%

16. Publication of Statement of Ownership. Will be printed in the Nov./Dec. 2003 (#72) issue of this publication.
17. I certify that all information furnished on this form is true and complete. (Signed) Terry Strohman, Editor

On occasion, we allow companies whose products and services may be of interest to you to send advertising mail to our subscribers. We are careful to choose ethical companies that have information of genuine interest to our subscribers. Most of our subscribers appreciate receiving these materials. However, if you prefer to have your name deleted from the mailing list made available to other companies, please write to us at ShopNotes, 2200 Grand Avenue, Des Moines, IA 50312

Contents

Features

Drill Press Belt Sander _____ 6

Get more out of your drill press by making it work harder. This shop-made accessory turns your drill press into a belt sander that works every bit as well as a floor model.

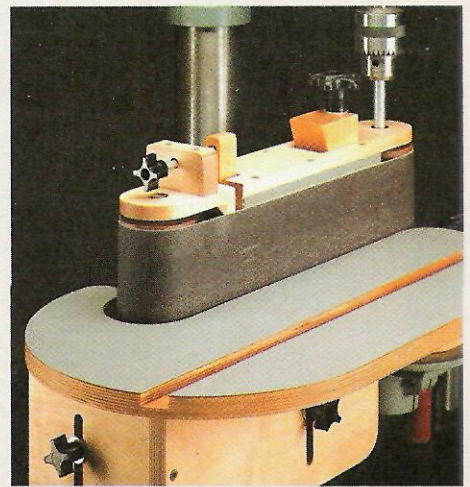

Drill Press Belt Sander page 6

Removing Rust with Electrolysis _____ 14

Removing rust from tools can be a big hassle. With a little "power" you can make quick work of it. We'll show you how to do it with ease using our step-by-step instructions.



Rust Removal page 14

Modular Outfeed System _____ 16

Make it easier to handle large or long stock safely on the table saw. This handy outfeed system can be configured in a number of ways to support long stock, large sheet goods, or anything in between.



Outfeed System page 16

Building a Laminated Benchtop _____ 20

Nothing says solid and heavy duty like a laminated benchtop. But making one without spending a lot of time getting it flat and smooth seems almost impossible. Check out the procedure we use that results in a perfectly flat top in no time at all.

Fold-Down Workstation _____ 22

A heavy-duty woodworking bench that takes up a little over four square feet of floor space when it's stored? You bet. Add some storage — an easy-access tool rack and a wall-mounted cabinet — and turn it into a full-fledged workstation.

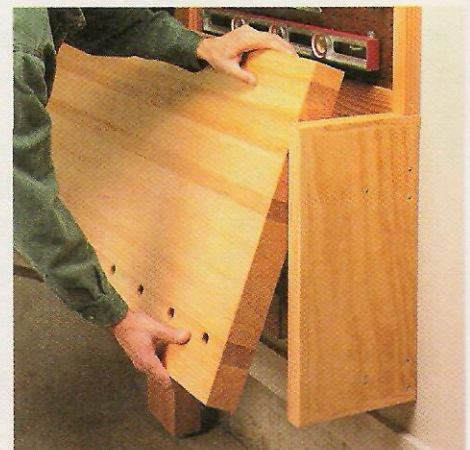

Fold-Down Workstation page 22

Departments

Readers' Tips _____ 4

Shop-tested tips to solve common woodworking problems.

Tool Chest _____ 32

Most sharpening systems can't do it all. But the one we use every day comes as close as you can get.

Shop Talk _____ 34

Have a great woodworking invention and want to protect it? Here's what you need to know about patents.

Sources _____ 35

Mail-order sources and supplies to help you complete the projects featured in this issue.

Readers' Tips

Big Dogs That Don't Bite

■ When clamping a workpiece in my workbench vise with bench dogs, I find that the small, metal dogs leave marks on the edges of the piece that are tough to sand out.

So, to solve this problem, I made some big, plywood bench dogs that slip over the regular dogs, as shown in the photo at right. The benefit is that the wide surface makes it easy to get a firm grip on the material being worked without leaving a mark.

The big dogs are made from squares of $\frac{3}{4}$ " plywood, as illustrated in the drawing at left. A hole cut in the middle of each dog is sized to fit

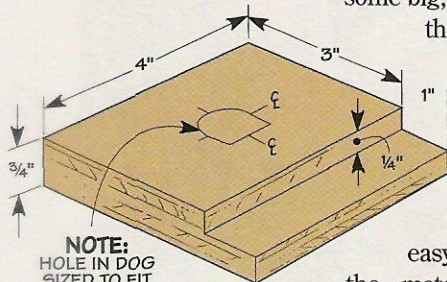

NOTE:
HOLE IN DOG
SIZED TO FIT
YOUR METAL DOG

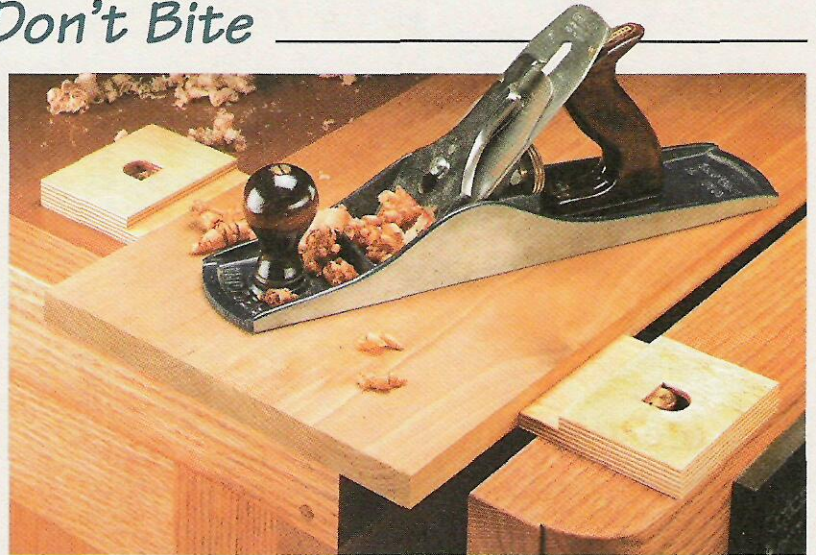

over the metal bench dog. Then I cut a wide, shallow rabbet along the front edge of each dog. As you can see in the photo, this allows you to work right up to the edge of the

workpiece. Or you can even clamp the workpiece in the rabbets to raise it above the dogs.

*Joe Holton
Houston, Texas*

Dial Indicator Depth Gauge

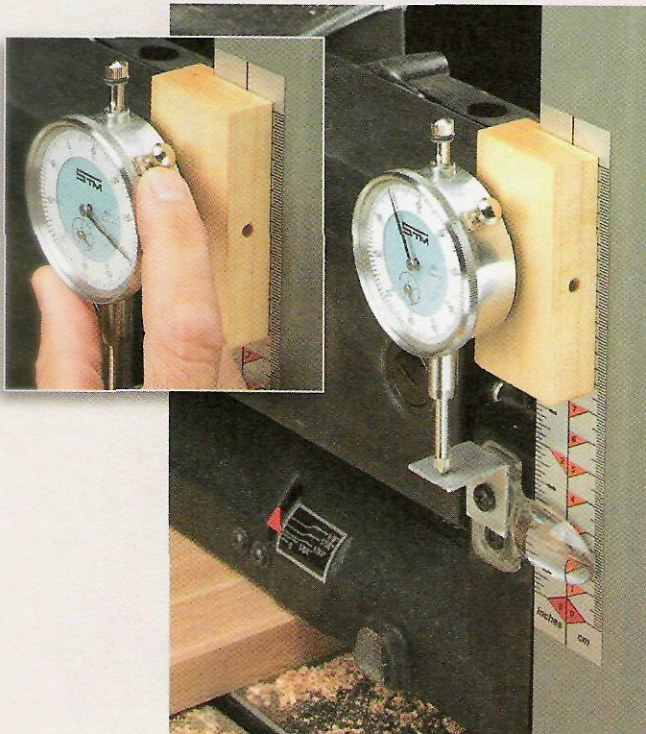

■ Planing stock to an exact thickness usually involves a lot of trial and error (and measuring) to get it right. The problem is, the thickness scale on the planer just isn't accurate enough to show how much material I have left to remove.

But I've come up with a simple dial indicator gauge that takes the guess work out of adjusting the planer. Now I can measure once and then dial in the perfect setting the first time. This saves me a lot of time, trouble, and frustration.

As you can see in the photo at left, the main part of the gauge consists of a dial indicator mounted to a hard wood block. The block has a rabbet on the back and a couple of screws and washers hold it firmly in place above the scale on the planer.

The second part of the gauge is a small, aluminum L-bracket fastened

to the thickness indicator. It acts as a contact point for the dial indicator.

Here's how the gauge works. Start by planing your stock slightly oversize in thickness. Then measure the stock with calipers or a tape measure, making note of how much material is left to plane off.

Next, without changing the cutting height of the planer, attach the gauge. Mount it so that the point of the dial indicator stays in contact with the L-bracket as the cutterhead (and thickness indicator) is lowered.

After setting the dial indicator to the amount that needs to be removed, as in the inset photo, lower the cutterhead (making several light cuts) until the dial indicator registers at "zero." Now your stock is planed to perfect thickness.

*John Green
Royal Oak, Michigan*

Quick Tips

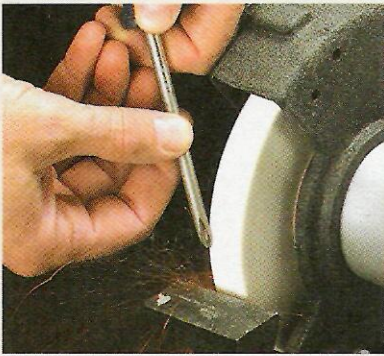

▲ To restore the head on a Phillips screwdriver, **Eric Johnson** of Edgewood, KY uses his grinding wheel to touch up the edges.



▲ **Richard Beal** of Fort Polk, LA keeps the lids from his fastener boxes in his storage bins to help him remember the type and size.



▲ Inexpensive, plastic spray bottles make a great applicator for **Todd Kamp** of Gig Harbor, WA to spray sealer on his outdoor projects.

Laminating Spacers

■ When gluing plastic laminate to a substrate with contact cement, I always used wood spacers or dowels to position the laminate. The problem was finding (or making) enough spacers to do the job.

To get around this, I started using plastic slats from window mini blinds, as shown in the photo at right. The curved shape of the slats easily holds the laminate off the substrate. And best of all, they're lightweight and can be stacked out of the way until I need them again.

*Tom Brodle
St. Louis Park, Minnesota*



Free Tips ON THE WEB

Get more wood-working tips **free**.

Visit us on the Web at **ShopNotes.com**

Sign up to receive a free shop tip by email every week.

Handy Tote for Sheet Goods

■ After reading through the article on working with plywood in *ShopNotes* No. 71, I wanted to share my version of a plywood tote that I've been using for the last few years.

The secret to my tote is a pair of PVC pipe hangers, like those shown in the inset photo below. You can buy them at any hardware store or home improvement center. I cut a piece of 2x6 long enough to make it comfortable to grip and then nailed the pipe

hangers to either side. A metal drawer pull screwed to the 2x6 makes a great handle.

*Dana Craig
Norwood, Massachusetts*

Send in Your Shop Tips

If you have a unique shop tip, we'd like to consider featuring it in one or more of our print or electronic publications.

We'll pay up to \$200 for a tip we publish. Just write down the tip and mail it to *ShopNotes*, Attn.: Readers' Tips, 2200 Grand Ave., Des Moines, IA 50312. Or FAX it to 515-282-6741, or send us an email at shopnotes@shopnotes.com. Please include your name, address, and daytime phone number in case we have any questions.

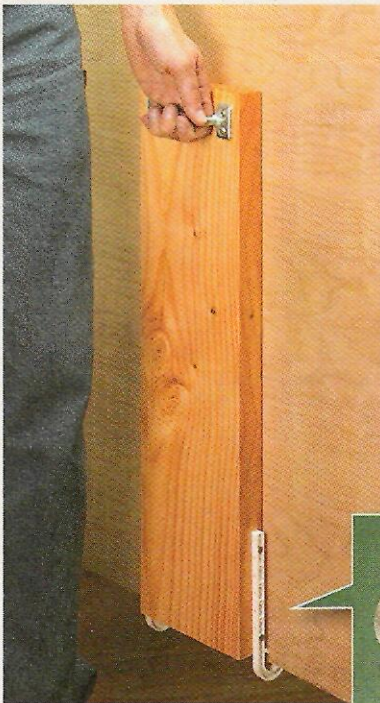

Drill Press Belt Sander

Speed up your sanding jobs with this shop-built drill press accessory.

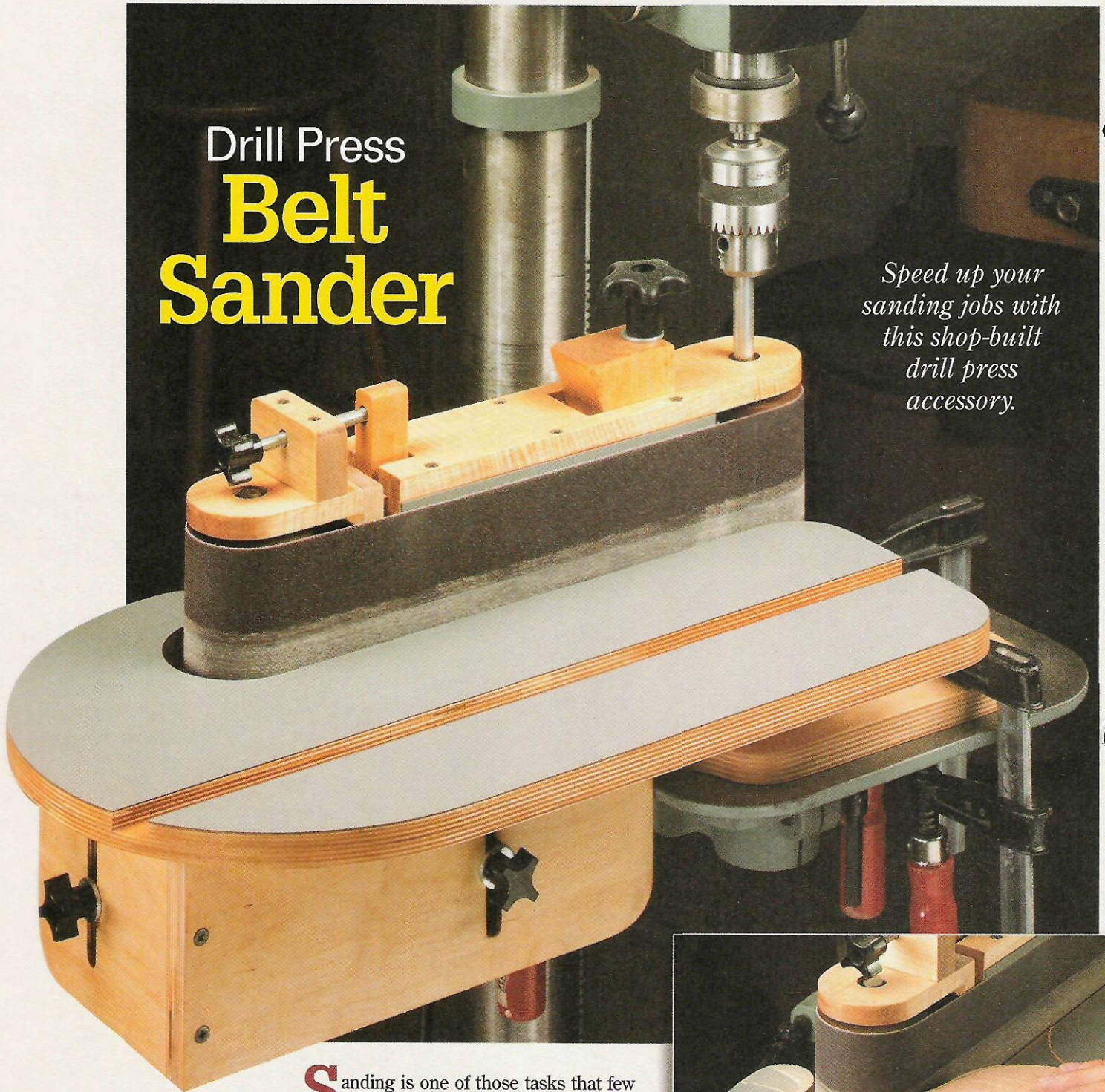

Sanding is one of those tasks that few people enjoy. So any time you can speed up the job, so much the better. The trouble is that stationary belt sanders take up a lot of shop space. And they can be rather expensive. But with the belt sander you see in the photo above, you can enjoy all the benefits of a large, stationary sander without having to invest in a new piece of equipment *or* give up valuable shop space.

What's unique about this belt sander is that it's powered by another tool that you probably already have in your shop — a drill press. The sander is simply clamped to the table of the drill press. Then a shaft on top of the sander is chucked up in the drill press — just like a drill bit. With a flip of the drill press switch, the sanding belt takes off and you're ready to start sanding.

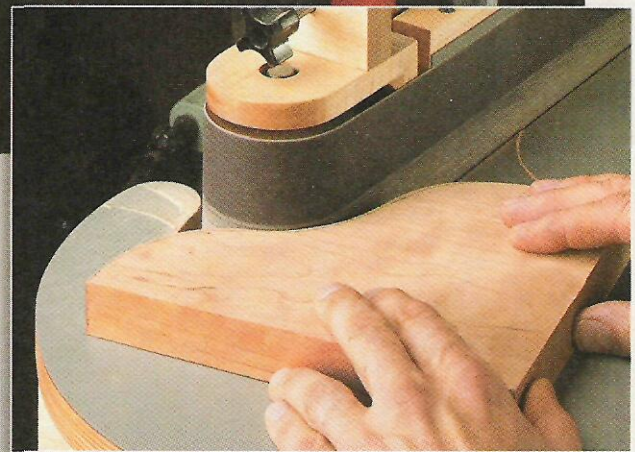

Although it looks small, this belt sander has all the features of a full-size machine — an adjustable-height table, separate controls for adjusting belt tension and tracking, and even a miter gauge slot. And for convenience, it uses commonly available, 4" x 36" sanding belts.

EXPLODED VIEW
OVERALL DIMENSIONS:
 25¼"L x 12¾"D x 14½"H

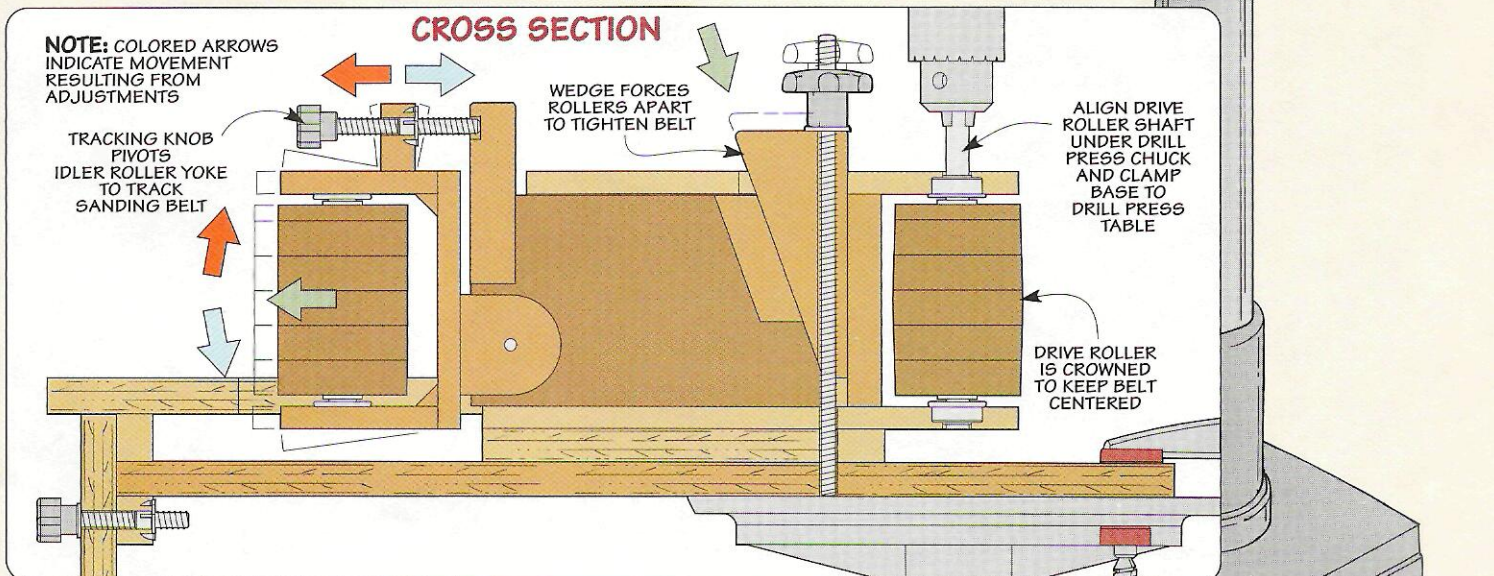
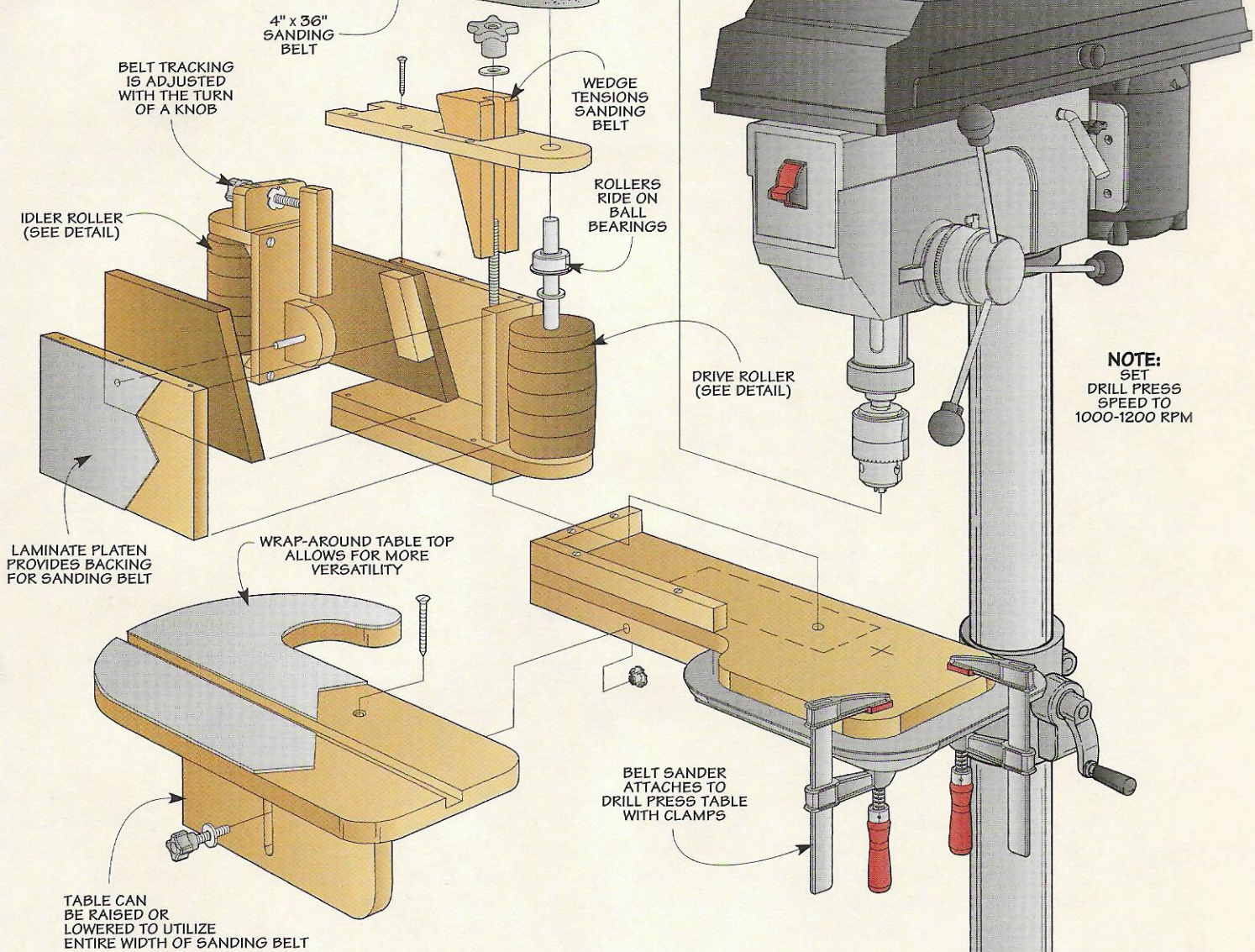

Idler & Drive Rollers

It may seem a bit unusual, but I built this belt sander from the inside out. I started with the rollers for the sanding belt first. Then I built the arms that hold the rollers. Finally, I finished up the sander by making the base and table. The reason for this is simple. By building the rollers first, you can size all the other parts to fit around them.

You'll need to make two rollers (A) — a drive roller and an idler roller. The only difference between these two is that the drive roller is slightly "crowned" toward the center to help in tracking the sanding belt. Fortunately, creating this crown is one of the final steps in making the rollers. So you can make the rollers identical to start with.

The rollers are made by cutting disks out of MDF (medium-density fiberboard) and then gluing the disks together. If you take a look at Figure 3, you can see that each roller is made up of six disks. Five of these disks are cut out of 3/4" MDF. But the sixth one is cut out of 1/2"-thick MDF. (I simply resawn a blank of 3/4" MDF down to 1/2" on the table saw to make the thin disks.)

To create the disks, I cut them out with a 3"-dia. hole saw, as you see in Figure 2 below. Don't worry if the hole saw leaves the edges of the

1 OVERVIEW

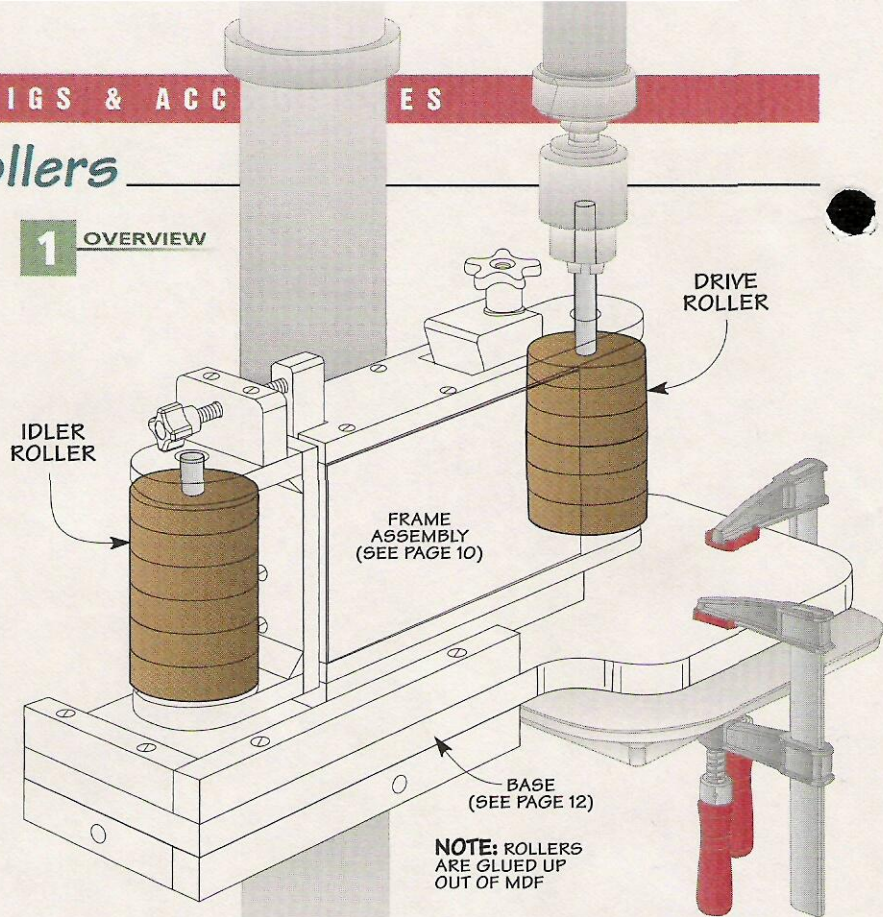

disks a little bit rough. You'll clean them up later. After cutting out all the disks, you'll need to enlarge the center holes left behind by the hole saw. This allows the disks to fit onto the 1/2"-dia. roller shaft that will be added later.

Assembly – Before gluing the disks together, I cut two shafts for the rollers out of 1/2"-dia. steel rod. (Note that these shafts are different lengths.) The idea here is to use the shafts to keep the disks

aligned while gluing them up, just as you see in Figure 3.

Shafts – Once both rollers are glued up, you can glue the shafts to the rollers with epoxy. There's nothing too complicated about this. However, in order to give the epoxy something to "grab" onto, I roughed up the surface of the shafts with a file before gluing them in place, as shown in the detail in Figure 3.

Now that you have both rollers glued up and the shafts epoxied in

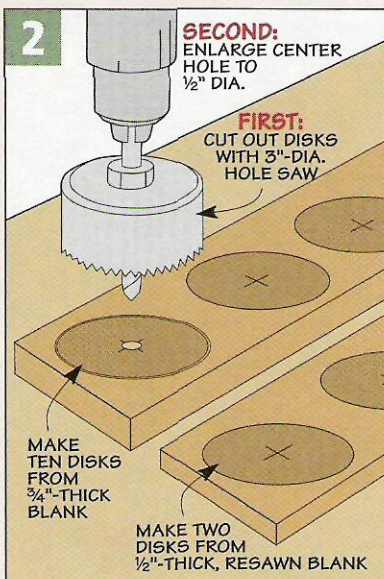

3 FIGURE

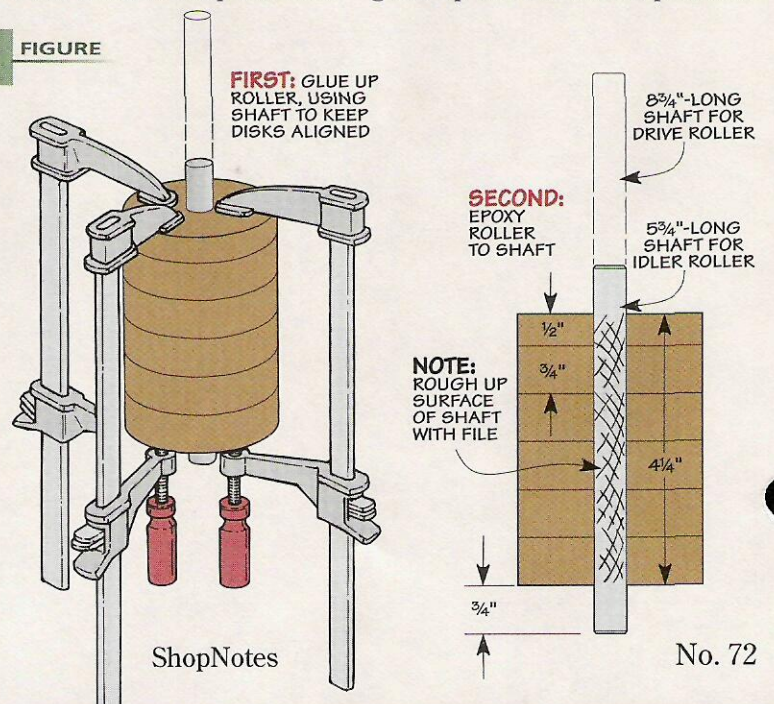

▲ **Rollers.** The rollers for the belt sander are built up out of several layers of MDF. Then they're trued up using a router table and jig (see opposite page).

place, you can “true up” the faces of the rollers. The goal here is to make each roller truly round and concentric with the shaft.

Truing Jig – The rollers are trued up on the router table, using a jig made especially for the purpose. The jig is really just an open box with a hole in two of the sides to hold the roller shaft. The roller is captured inside the box and then rotated by hand over a straight bit in the router table to true up the surface.

Figure 4 shows how the jig is made. It’s just screwed together (no glue) so that it can be taken apart and used to true up both rollers.

Setting Up the Jig – To use the jig, start by mounting the idler roller inside. (This is the roller with the short shaft.) To prevent the roller from rubbing against the sides of the jig, I added a machine bushing to each end of the shaft before mounting the roller in the jig.

Now set the roller and jig on top of your router table and adjust the height of the bit so that it’s about $\frac{1}{16}$ " higher than the bottom of the roller. Finally, position the fence on your router table so that the roller is directly over the router bit when the jig is pressed against the fence, see upper photo at right.

Using the Jig – Using the jig involves a little eye-hand coordination. You’re going to be sliding the

entire jig along the fence of the router table while slowly rotating the roller by hand at the same time. The whole thing is a little bit like patting your head while rubbing your stomach.

To make the process a little easier, it helps to clamp a couple of stop blocks to the fence of your router table. This way, you don’t have to worry about sliding the jig over too far and accidentally routing into the side of the jig.

Start at one end of the roller and work your way around the entire circumference. Then just slide the jig down a little bit until you work your way from one end of the roller to the other (Figure 4a). The goal is to end up with a roller $2\frac{7}{8}$ " in diameter.

Drive Roller – When it comes to truing up the drive roller, there’s a minor change to the procedure. The drive roller is crowned to a slight peak in the middle. This helps to keep the sanding belt centered on the rollers as it’s running. (I didn’t crown the idler roller because I wanted to leave it straight and square for sanding inside curves, see inset photo on page 6.)

To create this peak, I simply added a $\frac{1}{8}$ "-thick spacer to the bottom edge of one side of the jig to “cant” the roller slightly. Then I trued up one half of the roller, as you see in Figure 4b. After this

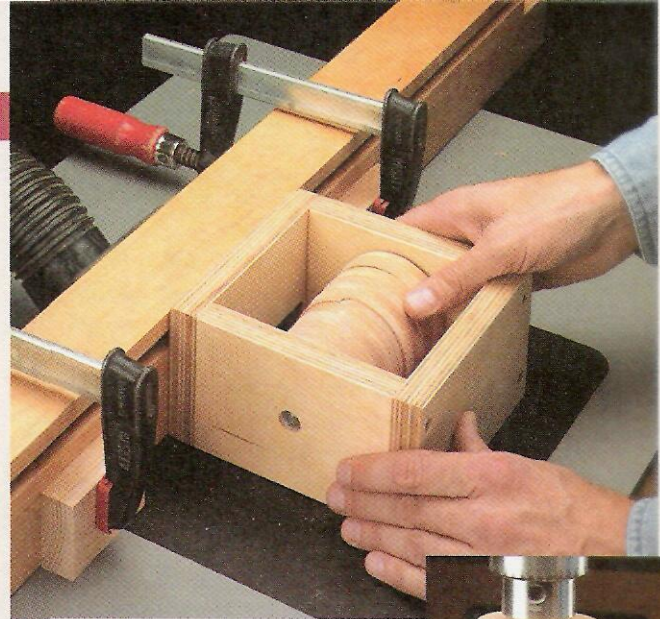

▲ **Truing Up the Rollers.** A simple jig allows you to true up the rollers on a router table. And a pair of stop blocks prevent you from routing too far past the ends of the rollers.



▲ **Sanding the Rollers.** Each roller is mounted in the drill press and sanded lightly to smooth out the rough surface left behind by the router.

end was smooth, I removed the spacer and taped it to the other side of the jig. Then I trued up the other half of the roller.

Smoothing the Rollers – The router table does a great job of making the rollers round, but it doesn’t leave the surface of the rollers very smooth. Fortunately, there’s an easy fix for this. Just chuck each roller up in the drill press and hold a piece of sandpaper up to the surface until it’s nice and smooth (see photo at right). Just make sure that when you’re sanding the drive roller you don’t sand out the “crown.”

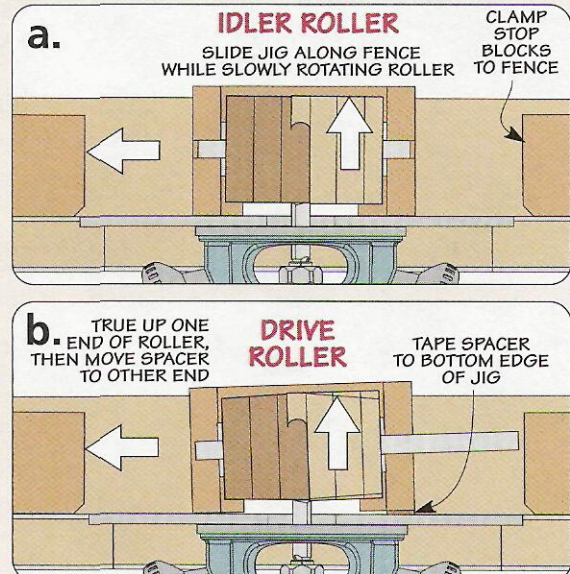
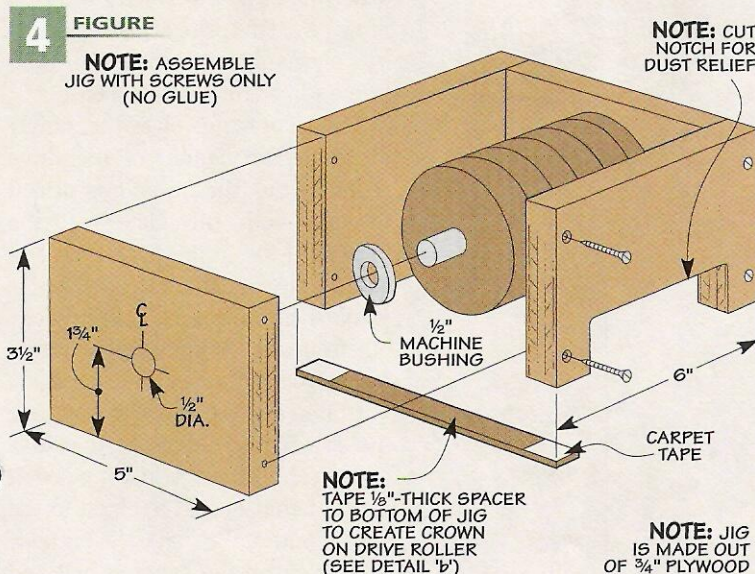

Frame Assemblies

Once you have the rollers completed, you can set them aside while you work on the frame of the belt sander. The frame is made up of two separate assemblies. The idler roller is mounted on a frame that includes a long, pivoting arm. This arm slides into the drive roller frame, which is built like a tall, narrow box. Figure 5 shows how the two frame assemblies fit together.

Drive Roller Frame - I started by making the drive roller frame. If you take a look at Figure 6 below, you'll see that this frame is really just a thin box that's open at one end. At the other end, the top and bottom of the box extend out past the end to serve as supports for the roller.

To make the drive roller frame, start by cutting out the *top* and *bottom (B)*, *sides (C)*, and *end (D)* from 1/2"-thick stock. These pieces will simply be glued and screwed together. Before you can do this, however, there are a few details to take care of.

First, you'll need to drill a counter-bored hole near the end of the top and bottom pieces for a flanged ball bearing that will be installed

5 FIGURE

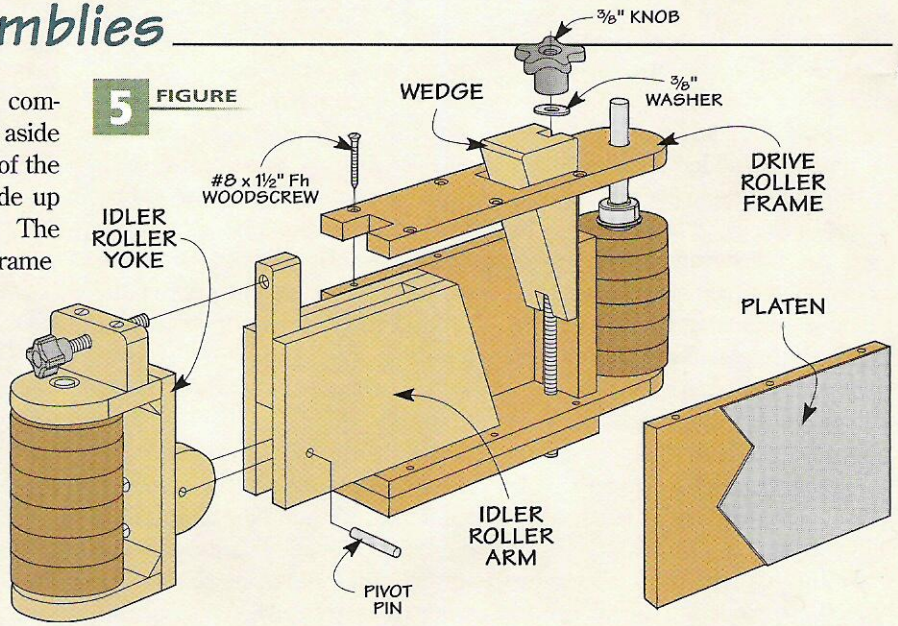

later (Figures 6a and 6b). Next, you'll need to cut a notch at the opposite end of the top piece, as you can see in Figure 6. This notch will receive part of the idler roller frame that will come later.

Finally, you'll need to cut a rectangular opening in the top piece for a hardwood wedge that will be used to tension the sanding belt. You can make this opening by drilling a hole at each corner of the opening and then cutting out the waste with a scroll saw or a jig (sabre) saw.

Before assembling the frame, you'll need to install the ball bear-

ings in the top and bottom pieces. These bearings are glued in place with epoxy. Just be careful that you don't get any epoxy on the face of the bearing where it could possibly run down inside and ruin the bearing mechanism.

Once the bearings are in place, you can assemble the frame with glue and screws. The sides and end are sandwiched in between the top and bottom. Just don't forget to add the drive roller and bushings when you're assembling the frame.

Mounting Plate - To create some clearance between the sanding belt and the base of the sander, the drive roller frame sits on a *mounting plate (E)*. This plate is just a piece of 3/4" plywood. Later, the plate and frame will be mounted to a base.

The mounting plate is simply glued to the bottom of the drive roller frame. Then a hole is drilled through both the plate and the bottom of the frame for a threaded rod (Figure 6). This threaded rod is epoxied into place so that it sticks out from the mounting plate about 1/2", as you can see in Figure 6a.

Platen - The last step to complete the drive roller frame is to add a platen. The platen is just a piece of plastic laminate that is glued to the side (front) of the frame. Its purpose is to back up the sanding belt and

6 FIGURE

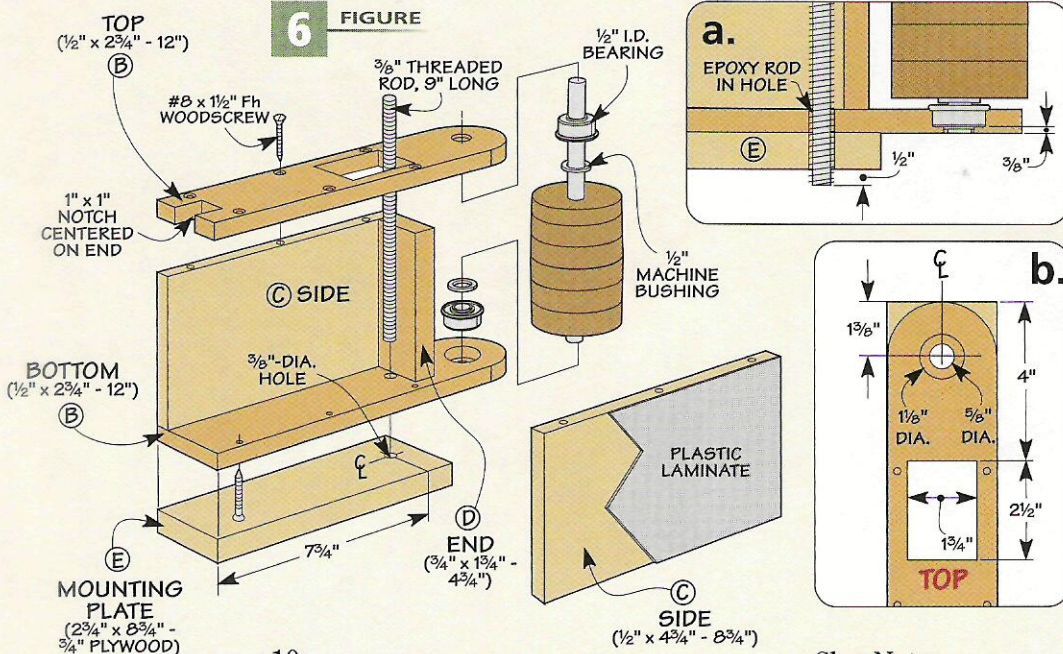

provide a smooth, slick surface for it to travel over. I simply cut the laminate to size and glued it to the side of the frame with contact adhesive.

IDLER ROLLER FRAME

The idler roller frame is constructed a little bit differently than the drive roller frame. It consist of two sections. The roller is held by a yoke. This yoke is pinned to an arm so that it can pivot, allowing you to "track" the sanding belt.

To make the yoke, I began by cutting out the yoke top and bottom (F), back (G), and bracket (H) from 1/2"-thick hardwood. The top and bottom pieces each get a ball bearing installed in them, like you did with the drive roller frame. Then I drilled a hole in the bracket for a pivot pin that will be added to the frame later. After this is done, you can assemble the yoke with glue and screws. Just make sure you don't forget to include the roller and machine bushings (Figure 7). Finally, to reinforce the yoke, I added a couple of corner blocks to the inside corners.

Tracking Bracket - The last part to add to complete the yoke is a tracking block (M). This is just a block of wood with a T-nut installed (Figure 8). It gets screwed to the top of the yoke. To make the tracking knob that fits in the bracket, I simply

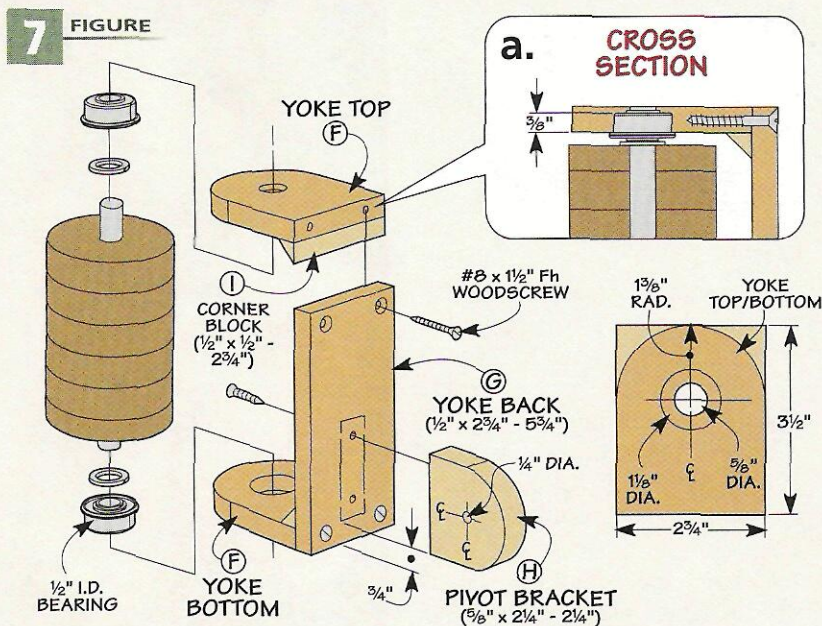

epoxied a star knob onto the end of a piece of threaded rod.

Arm - With the yoke complete, you can build the arm that holds it. As you can see in Figure 8, the arm is made up of four pieces. It's basically a pair of sides with a couple of blocks in between to act as spacers. One end of the arm is tapered to mate with a tensioning wedge that will be added later.

If you take a look at Figure 8 below, you'll notice that the tracking block at the square end of the arm sticks up above the top edge of the side pieces. This block

serves as a stop for the tracking adjustment knob. A shallow hole is drilled near the end of this block to accept the tip of the threaded stud of the tracking knob (Figure 8a).

After gluing up the arm, you can add the yoke. It's simply held in place with a steel pivot pin that passes through the sides of the arm. To do this, I drilled a hole all the way through both sides of the arm for the pivot pin. Then I drove the pin in place, capturing the yoke bracket in between the sides of the arm. (You may have to use a little epoxy to hold the pin in place.)

Once you have the idler roller frame complete, you can slide it into the drive roller frame. The arm should slide freely inside the drive roller frame. If it doesn't, you may want to sand the faces of the arm and apply a little paste wax.

Wedge - The only thing left to complete the frame assemblies is to add a tensioning wedge. This wedge is cut from a hardwood blank, as you can see in the margin drawing at right. A groove is cut along the back of the wedge to allow it to fit around the threaded rod that is epoxied into the drive roller frame. A knob and washer are used to hold the wedge in place. As the knob is tightened, the wedge gradually forces the two roller frames apart (Figure 5).

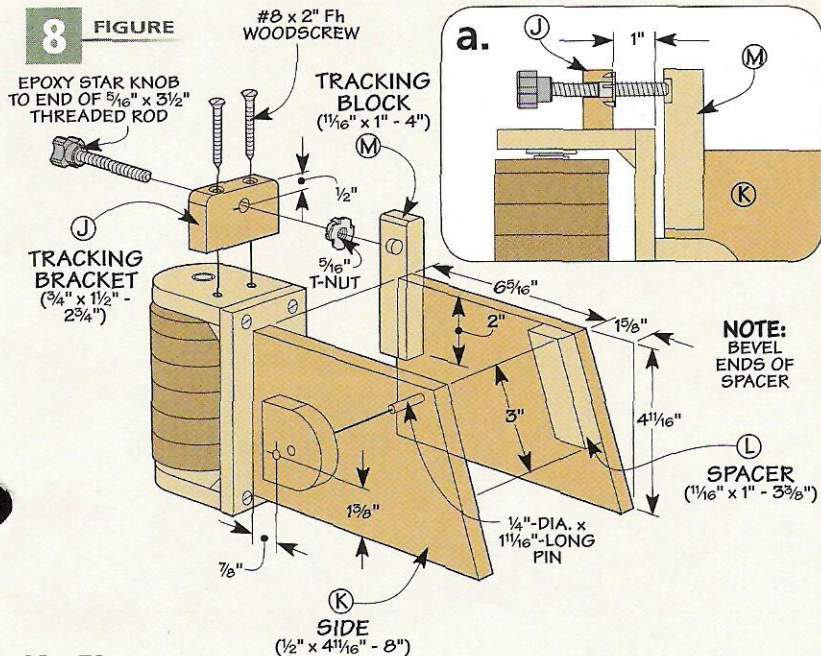
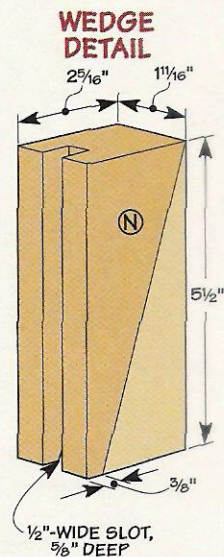

Base & Table

At this point, the most difficult parts of the sander are complete. All that remains now is to make the base and adjustable table. The table supports your workpiece and can be adjusted up or down to utilize the entire width of the sanding belt (see photo at left). The base provides a platform for the sander and gives you a place to clamp the sander to your drill press table (see inset photo).

Base – As you can see by taking a look at Figure 9, the *base (O)* of the sander is really little more than a piece of 3/4" plywood. It's cut to shape and the edges are sanded smooth. Then, after drilling a 3/8"-dia. hole in the base for the tensioning rod, the drive roller frame assembly can be glued down to the top of the base (Figure 9). Then you can set the sander aside while working on the table.

Table – Like the base, the table is also made out of 3/4" plywood. The shape of the table is designed to allow it to wrap around the idler roller so that you can sand inside curves. I started by cutting the table top (*P*) to shape as shown in Figure 10, and then sanding the edges.

To help support the table and allow it to slide up and down, the top is

attached to a couple of plywood aprons. Before screwing the top to the aprons, however, you'll need to cut a slot in each apron for a locking knob that is added later.

Once the table is assembled, you can add a piece of plastic laminate to the top. This provides a tough, smooth surface. The final step to complete the table is to cut a miter gauge slot along the length of the top.

Table Supports – The table rests against the edge of the base and is held in place by a couple of star knobs. In order to provide a larger surface to support the table, I beefed

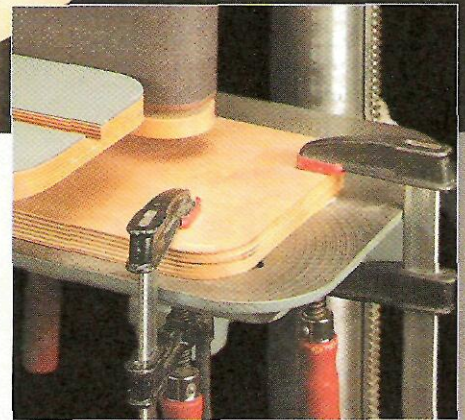
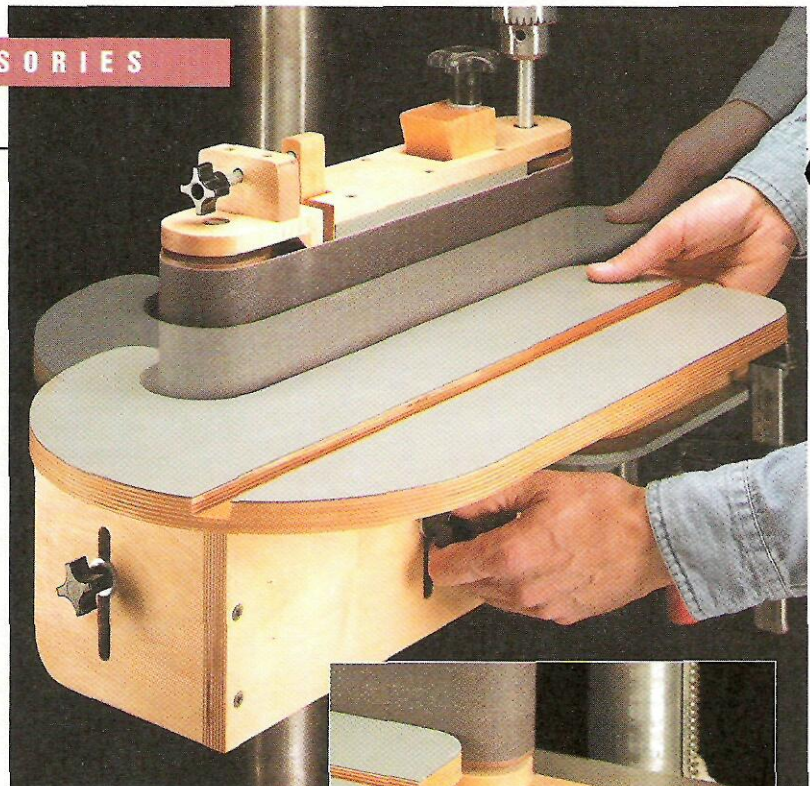

9 FIGURE

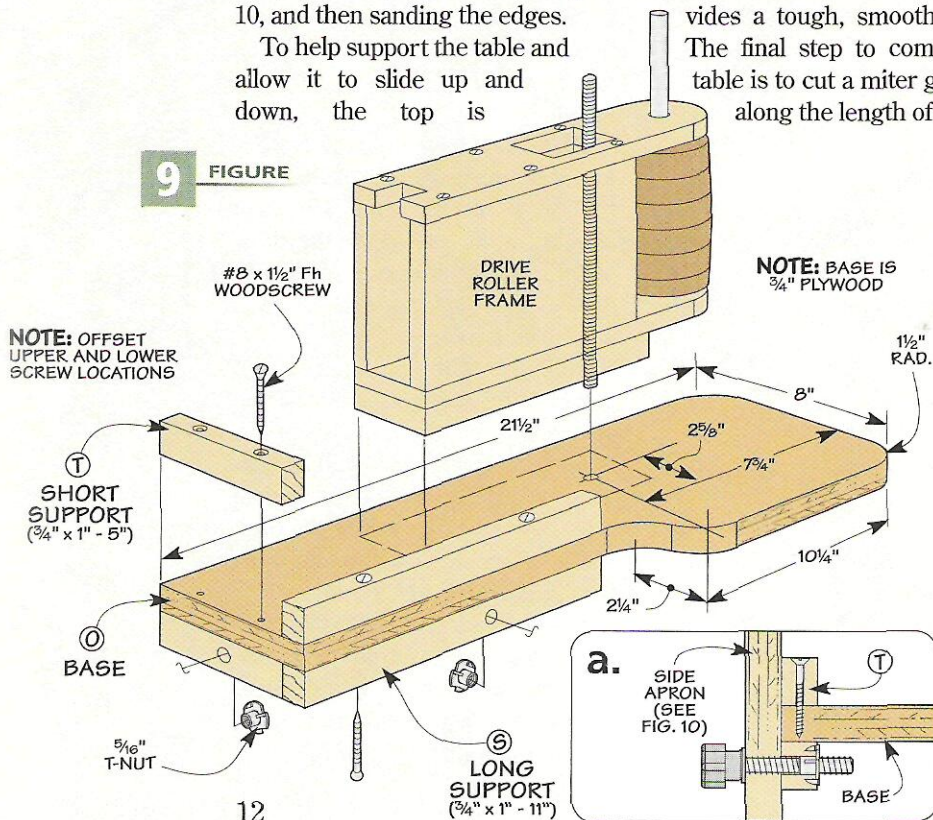

Hardware

- (4) 1/2" I.D. Flanged Ball Bearings
- (1) 3/8" x 9" Threaded Rod
- (1) 1/2" x 15" Steel Rod
- (1) 1/4" x 1 1/16" Steel Rod
- (4) 1/2" Machine Bushings
- (1) 3/8" Star Knob
- (1) 5/16" Star Knob
- (2) 5/16" Star Knobs w/1/2"-long studs
- (2) 5/16" Washers
- (1) 3/8" Washer
- (3) 5/16" T-Nuts
- (34) #8 x 1 1/2" Fh Woodscrews
- (2) #8 x 2" Fh Woodscrews
- (1) 5/16" x 3 1/2" Threaded Rod
- (1) Plastic Laminate (24" x 24")
- (1) 4" x 36" Sanding Belt

up the edge of the base by adding some supports. These are just blocks of wood that are screwed to the top and bottom faces of the base, flush with the edges (Figure 9a).

Hardware – The star knobs that hold the table in place simply thread into T-nuts that are mounted in the lower table supports. To locate the holes for these T-nuts, I placed the table against the edge of the base and marked the location of the apron slots onto the lower table supports. Then I just drilled a couple of holes and installed the T-nuts. After attaching the table, you can slip a sanding belt over the rollers and clamp the sander to your drill press, see box below. 

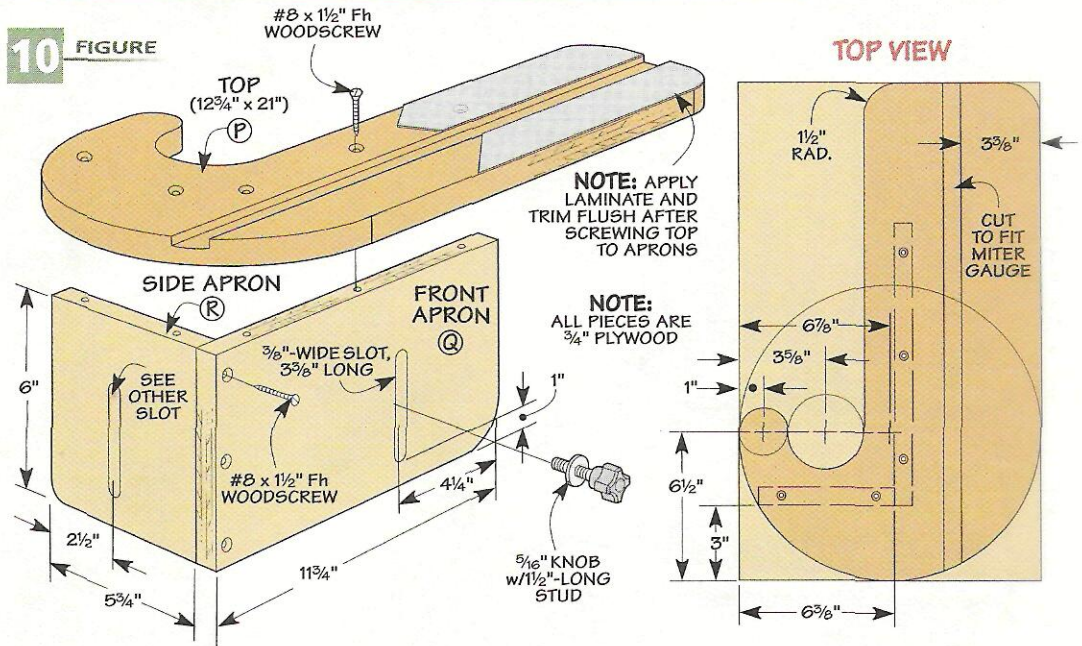

Setup

To set up the sander, slip a sanding belt over the rollers, as shown in the first photo. Then clamp the sander to the table of your drill press so that the drive roller shaft is directly below the drill chuck. Lower the drill press spindle and tighten the chuck around the shaft. Then lock the drill press spindle in place.

With the setup complete, there are just a couple of adjustments to make. To tension the sanding belt, simply turn the large knob on the wedge. (Tighten it just enough so the belt doesn't slip.) Then to get the belt to track evenly on the rollers, turn the small star knob at the end of the sander, see second photo.

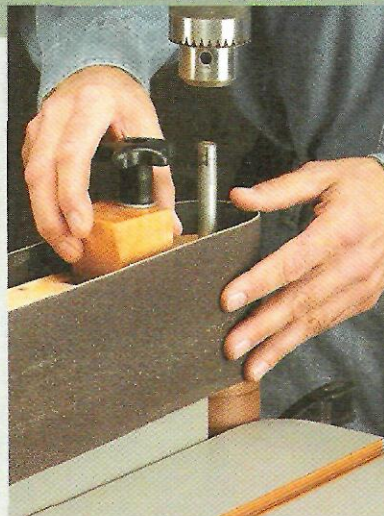

▲ **Belt Change.** To install or remove the sanding belt, loosen the knob and lift up the wedge to release the tension on the sanding belt.

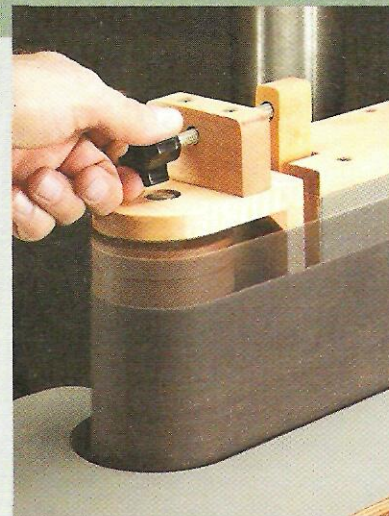

▲ **Tracking.** Turning a knob at the end of the sander will cause the idler roller to pivot slightly, thereby centering the belt.

Materials

A Rollers (2)	2 7/8 dia. x 4 1/4 MDF	K Arm Sides (2)	1/2 x 4 11/16 - 8
B Frame Top/Bottom (2)	1/2 x 2 3/4 - 12	L Spacer (1)	1/16 x 1 - 3 3/8
C Frame Sides (2)	1/2 x 4 3/4 - 8 3/4	M Tracking Block (1)	1/16 x 1 - 4
D Frame End (1)	3/4 x 1 3/4 - 4 3/4	N Wedge (1)	1 1/16 x 2 5/16 - 5 1/2
E Mounting Plate (1)	2 3/4 x 8 3/4 - 3/4 Plywood	O Base (1)	8 x 21 1/2 - 3/4 Plywood
F Yoke Top/Bottom (2)	1/2 x 2 3/4 - 3 1/2	P Top (1)	12 3/4 x 21 - 3/4 Plywood
G Yoke Back (1)	1/2 x 2 3/4 - 5 3/4	Q Front Apron (1)	6 x 11 3/4 - 3/4 Plywood
H Pivot Bracket (1)	5/8 x 2 1/4 - 2 1/4	R Side Apron (1)	6 x 5 3/4 - 3/4 Plywood
I Corner Blocks (2)	1/2 x 1/2 - 2 3/4	S Long Supports (2)	3/4 x 1 - 11
J Tracking Bracket (1)	3/4 x 1 1/2 - 2 3/4	R Short Supports (2)	3/4 x 1 - 5

Removing Rust with Electrolysis

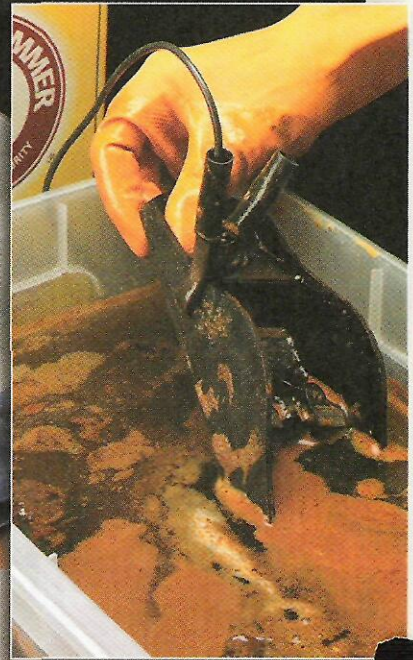
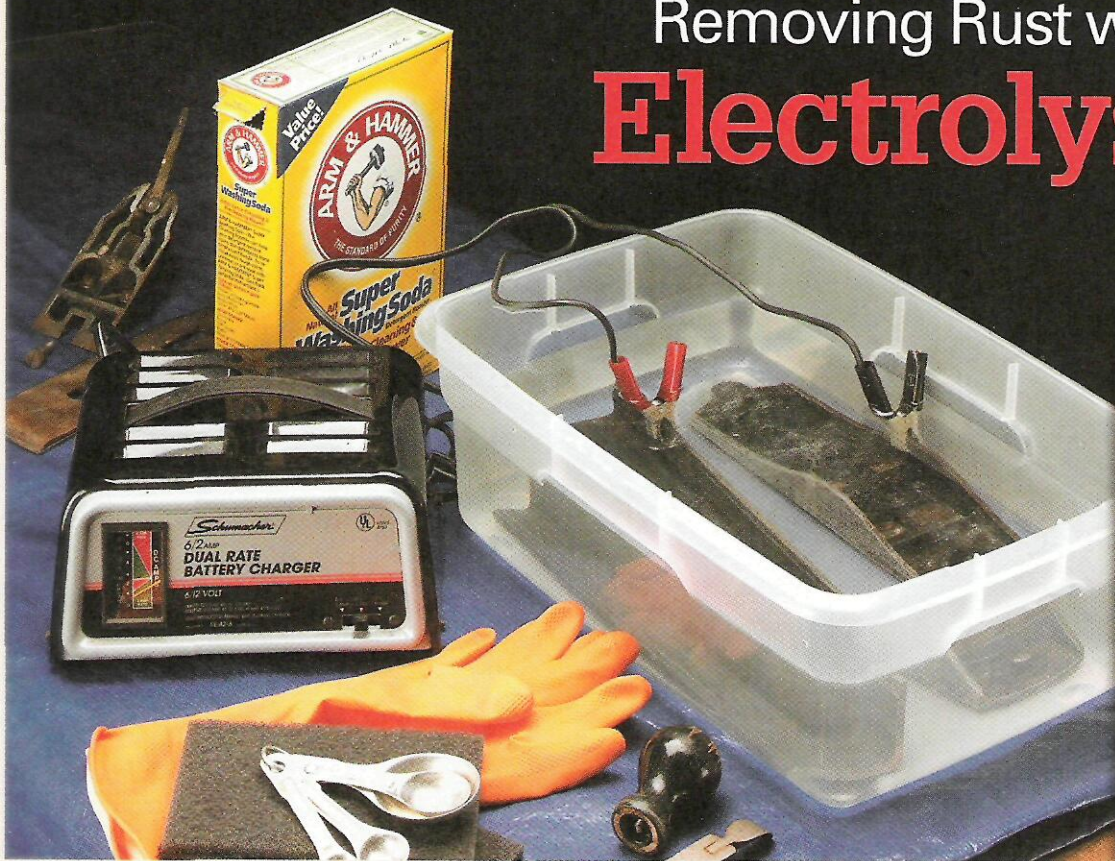

If you're like me, you've probably always thought of "electrolysis" as something that women have done to remove unwanted facial hair. But a couple of years ago, I heard about a *different* type of electrolysis — a kind that's used to remove rust. I decided to give it a try on an old, rusty hand plane that I had lying around. The results floored me. When I was finished, you couldn't tell that there had ever been a hint of rust on the plane. (Check out the

before and after photos of the plane below to see what I'm talking about.)

How it Works — Electrolysis is simply a method of removing rust through a chemical reaction. But don't worry — you won't need a Ph.D. in chemistry to try electrolysis. In fact, the process is really quite simple and requires just a few common household items.

In a nutshell, the rusty tool is submerged in a tub containing a solution of water and a little washing soda. Then an electric current is passed through the solution to create a reaction that removes the rust.

Benefits — There are a couple of benefits to using electrolysis to clean up a rusty tool. First, it's a lot gentler on the tool than any other method of rust removal. Sanding, grinding, sandblasting, wire wheels and chemical rust removers all remove metal along with the rust. They tend to "overclean" the tool, destroying the original "patina" and leaving the tool looking unnatural. Electrolysis doesn't do this because it removes only the rust — not the metal.

Another advantage to using electrolysis is that it requires a lot less

effort than most other methods. You simply let the electrolysis do the work, and then after a couple of hours, wipe the tool clean. Shop Note: Electrolysis is highly effective at removing rust, but it won't restore the pitted surface of the metal.

Supplies — The first thing you'll need to do is round up the necessary supplies. You'll need a plastic bucket or tub that's large enough to completely submerge the object you're treating. You'll also need a fine abrasive pad (I use the gray 3M finishing pads) and a box of washing soda. (I found washing soda in my local grocery store, right next to the laundry detergents.) Since washing soda can be hard on your skin, you might also want a pair of rubber gloves to protect your hands.

Next, you'll need an *anode*, which is nothing more than a piece of steel. Any old piece of steel will work (as long as it's not galvanized and free from rust or scale). The last item you'll need is a small, automotive battery charger. Try to find one with an



◀ *Before.* The body of this hand plane is covered with surface rust.

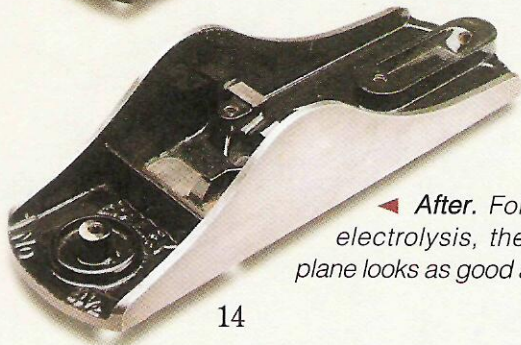

◀ *After.* Following electrolysis, the same plane looks as good as new.

ammeter. It will tell you if the process is working. (You can buy a battery charger for around \$35.)

Safety – Before getting started, there are a couple of safety points to mention. One of the by-products of electrolysis is the creation of hydrogen gas. Although the amount of gas produced is small, you should set up your electrolysis tub where there is plenty of ventilation and away from any open flames.

Any time you're mixing water and electricity, a little caution is in order. Obviously, don't ever put your hands in the tub of water while the battery charger is plugged in. And don't leave the tub unattended where a child or pet might happen across it.

Finally, although electrolysis doesn't seem to affect the japanning on most hand planes, it may soften and remove some paints. So if you're working on a valuable tool, you might want to test a small area first.

GETTING STARTED

Once you have all your supplies together, you're ready to get started. First, you'll want to remove any parts of the tool that are made out of wood, brass, or galvanized metal. Then wash the tool in warm water to remove any dirt or debris.

Preparing the Solution – Now fill the plastic tub with enough clean water to cover the tool and add a little washing soda (about one tablespoon per gallon, see Step 1). Then place your anode in the water on one side of the tub and the rusty tool on the other side. (Make sure that the two aren't touching or you'll short out the battery charger.)

Before plugging in the battery charger, hook up the positive (red) lead of the charger to the anode and the negative (black) lead to the tool (Step 2). If your charger has more than one amperage setting, turn it to the lowest one and then switch it on.

Tiny Bubbles – Within a few seconds, you should start to see tiny bubbles forming on the surface of the tool and rising to the top of the water (see photo on opposite page).

This tells you that the process is working. If you don't see any bubbles, or if the ammeter needle doesn't move when you turn the charger on, unplug it and double check the connections.

The electrolysis will start working on the rusted surfaces that directly face the anode. To get the best results, it helps to turn the tool around half way through the process so that all surfaces have a chance to "de-rust." Just make sure to unplug the battery charger first.

Clean Up – After a couple hours, you can turn the charger off and take the tool out of the tub. But don't expect it to look bright and shiny at this point (see inset photo on oppo-

site page). The areas that were rusted will look black. But this is easy to remedy. Just take the tool over to the sink and rinse it off. Then gently scrub the tool with the 3M finishing pad (Step 3). The metal underneath should be clean and free of rust. If it's not, you'll need to treat the tool a little longer.

Finishing Up – Once the tool has been cleaned and washed, it can begin to rust again almost immediately. To prevent this, I like to dry the tool off with an absorbent cloth and then place it in a low-temperature oven for about an hour to make sure it's dry. After this, you can apply a coat of paste wax to prevent new rust from forming (Step 4). 

Step-by-Step

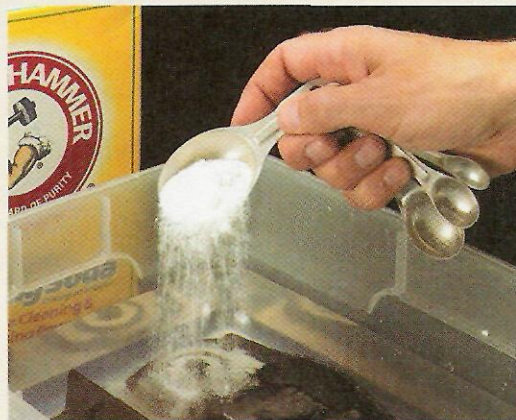

1 To get started, mix a tablespoon or two of washing powder in a plastic tub filled with enough water to cover the top of the tool.

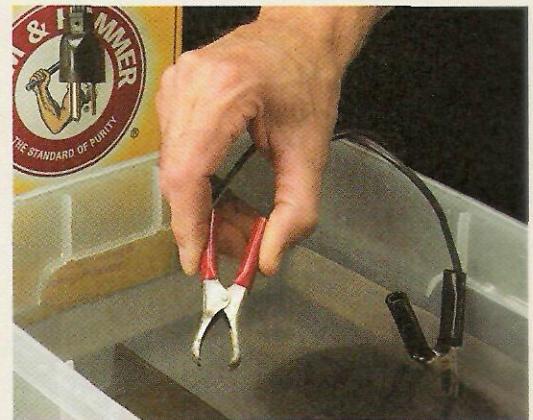

2 With the battery charger unplugged, clamp the negative lead to the tool and the positive lead to the anode (a scrap piece of steel).

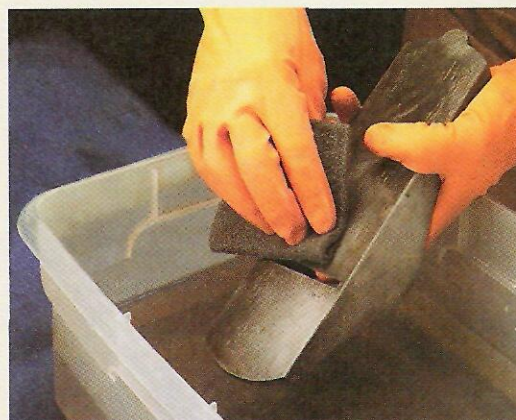

3 Once the electrolysis is complete, rinse the tool off in clean water and scrub the surfaces gently with the abrasive pad.



4 To help prevent future rust from forming, dry the tool thoroughly and then apply a coat of paste wax to all the bare metal surfaces.



Modular Outfeed System

This expandable outfeed table can be rearranged to suit all your needs.

I've always been envious of woodworkers who have table saw outfeed supports the size of aircraft carriers. It surely makes cutting long boards a lot easier, not to mention full sheets of plywood. But the reality is that a lot of us simply don't have that much space in our shops. Which is why we came up with the project shown here.

Outfeed System – Instead of building a single, large outfeed table, I created an outfeed *system* made up of five separate outfeed supports. You can gang the supports together to create one large table, like you see in the photo above. Or you can separate the units and strategically place them around your table saw to give you

support exactly where you need it. (See the photo on page 19.) What's great about this system is that it gives you large-scale capabilities without forcing you to permanently give up valuable floor space in your shop.

Modular – Although we built five separate units, the modular design of these outfeed supports is such that you can build as few or as many as you want. (A single support makes a great outrigger for crosscutting long workpieces, see photo on opposite page.) The feet are staggered in position to allow the individual units to nest together. And catches on the sides of the supports hold them all together.

EXPLODED VIEW
OVERALL DIMENSIONS:
 34"W x 14³/₄"D x 35"H

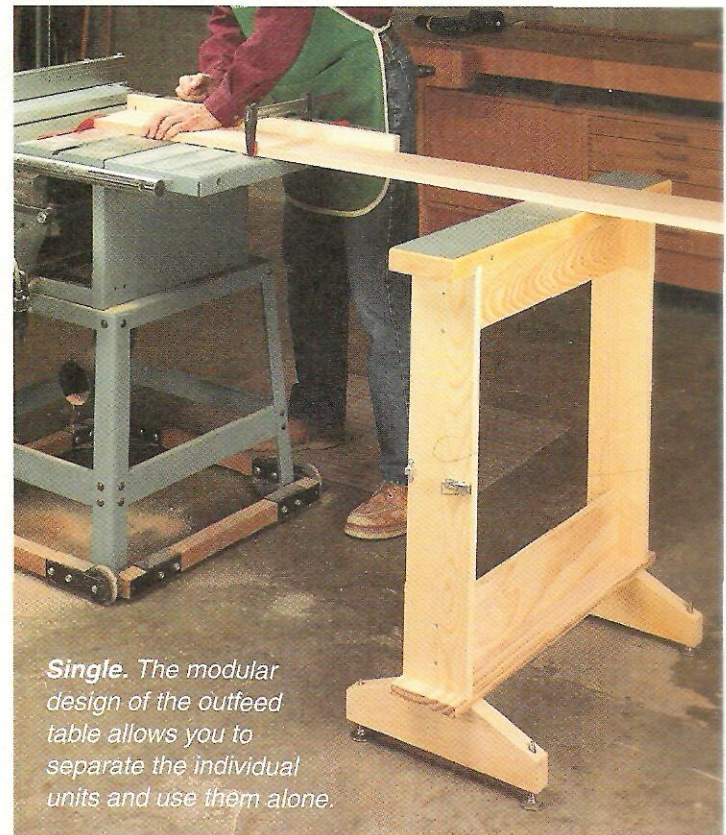
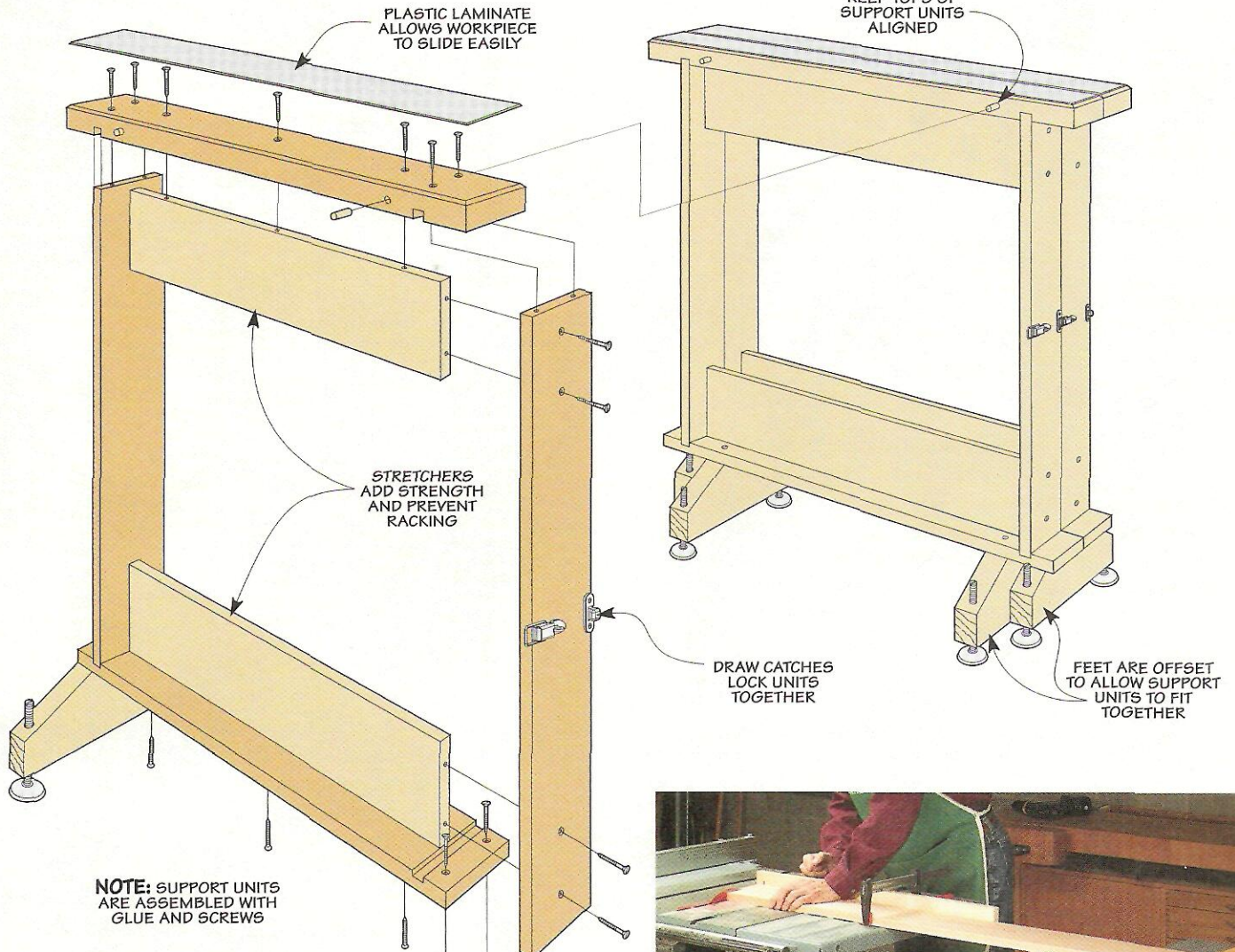

Single. The modular design of the outfeed table allows you to separate the individual units and use them alone.

Hardware (1 unit)

- (4) 3/8" x 4" Swivel Levelers
- (4) 3/8" T-Nuts
- (1) Plastic Laminate (5" x 34")
- (22) #8 x 2" Fh Woodscrews
- (2) 3/8"-dia. Wood Table Pins
- (1 pr.) 2 3/4" Draw Catches

Materials (1 unit)

A Bottom (1)	3/4 x 5 - 31
B Sides (2)	3/4 x 5 - 28 1/2
C Top (1)	1 1/2 x 5 - 34
D Stretchers (2)	3/4 x 5 - 26 1/2
E Feet (2)	1 1/2 x 4 - 14 3/4

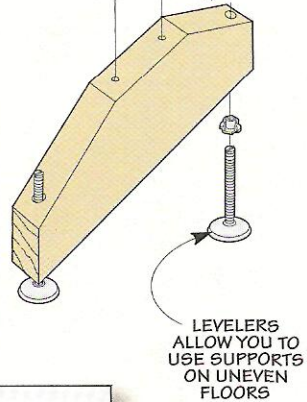

Support Unit

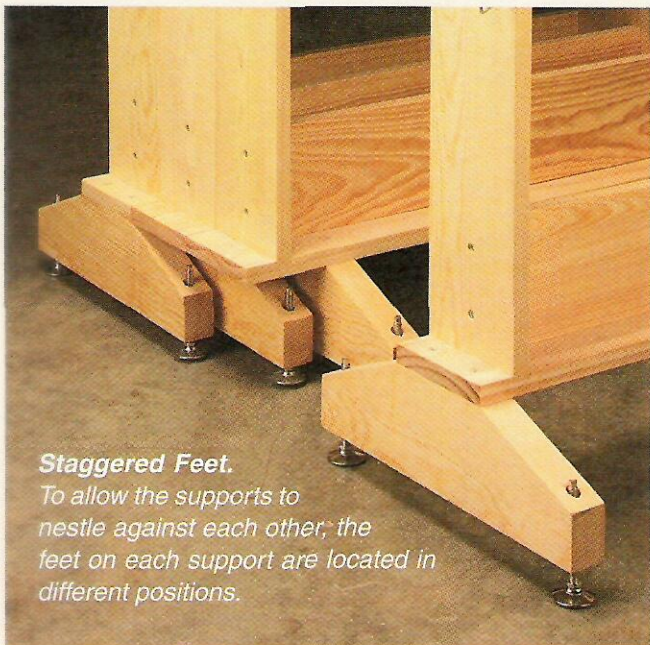

Staggered Feet.

To allow the supports to nestle against each other, the feet on each support are located in different positions.

As I mentioned earlier, the outfeed table is made up of five separate support units. With the exception of the positions of the feet, these units are all identical. So it makes sense as you are building them to cut out the parts for all five units and work in a "production-style" method.

Frame – As you can see in Figure 1, the main body of the support unit is simply a wood frame. To make this frame, start by cutting the *bottom* (A) and *sides* (B) to size from 3/4"-thick stock and the *top* (C) from 1 1/2"-thick stock. (I used pine.) The dimensions for these pieces are shown in Figure 1.

After you have the pieces cut to size, you can start on the joinery. Although glue and screws are used to hold the pieces together, the side

1 FIGURE

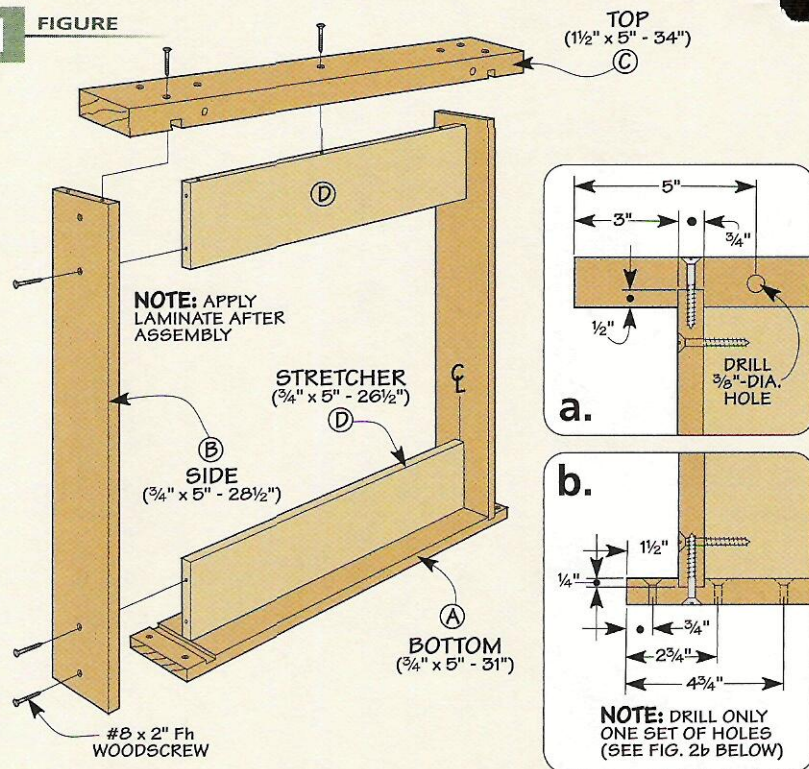

pieces fit into dadoes in the top and bottom. This helps keep everything aligned. I made these using a dado blade on the table saw. Start by cutting the dadoes on the bottom piece first, positioning them according to the dimensions shown in Figure 1b.

The dadoes in the top piece need to line up with the dadoes in the bottom piece. So when you're laying out the dadoes on the underside of

the top, pay attention to the spacing *between* the dadoes, rather than the spacing from the dadoes to the ends of the workpiece (Figure 1).

After you've cut all the dadoes, you need to drill a few holes in both the top and the bottom pieces before you can assemble the frame.

To start with, I drilled two pairs of countersunk holes in each bottom piece for the feet that will be added later. There's just one thing to be aware of here. In order to allow the support units to nest together, the feet are staggered on each unit. So there are three different locations for drilling the holes, as you can see in Figure 2b. (If you're making five support units, you'll need to make two units with the feet in the first position, two with the feet in the second position, and one with the feet in the third position.)

For the top piece, you just need to drill a couple of holes on each edge of the piece for some alignment pins that will be added later (Figure 1a).

Assembly – Once you have all the holes drilled, you can assemble

2

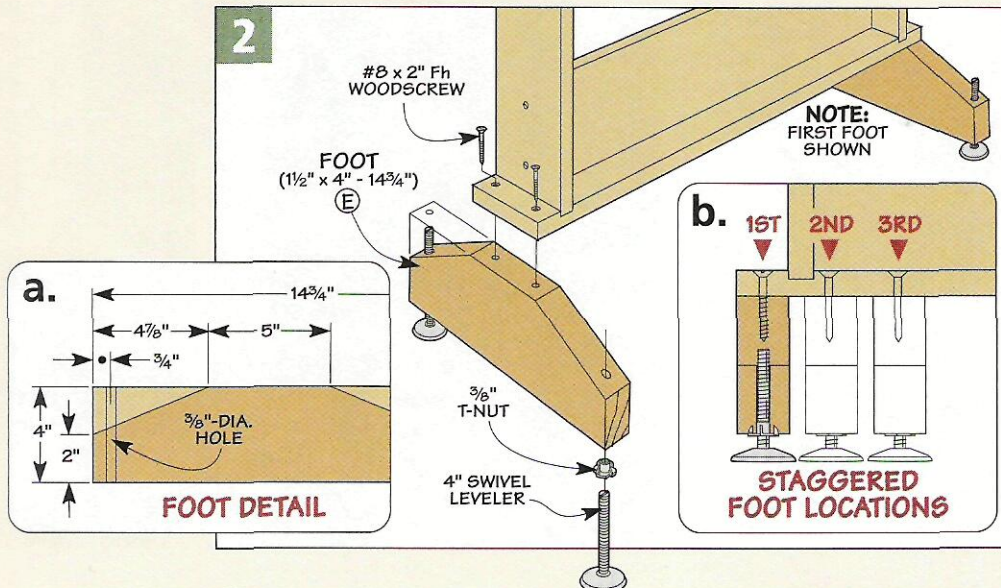

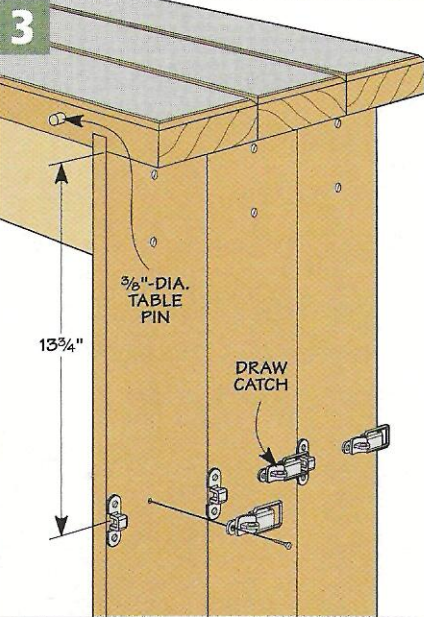

NOTE: ROUT 1/4" CHAMFER AROUND EDGES OF EACH TOP AFTER APPLYING LAMINATE

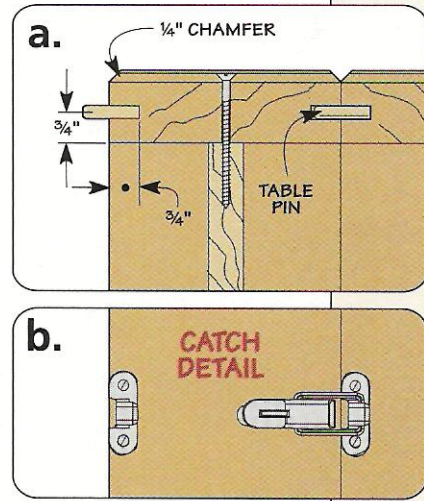

the pieces by simply gluing and screwing them together.

Stretchers – To help strengthen the frames, I added a couple of stretchers — one at the top and one at the bottom. These *stretchers* (*D*) are just cut to length to fit in between the sides and are then glued and screwed in place, as shown in Figure 1.

Laminate – To help reduce friction on the top of the outfeed support, I added a smooth piece of plastic laminate to the top. After gluing the laminate down and trimming it flush with the edges, I routed a chamfer around the top (Figures 3 and 3a).

Feet – There's not much to making the *feet* (*E*). Each one starts off as a 1 1/2"-thick blank. After drilling a couple of holes near the ends of the blank for some levelers, the top of each foot is tapered on a band saw and then sanded smooth. The goal here is to leave a 5"-wide

flat spot on top of each foot on which to mount the frame (Figure 2a).

Hardware – Before attaching the feet, you can install the T-nuts and levelers as shown in Figure 2. Then the feet are just screwed to the frame (Figure 2b).

To help hold the support units

together when you are using them as a single outfeed table, I added a draw catch to each side, as you see in Figure 3. Then finally, to help keep the support units aligned, I glued some wooden table leaf alignment pins into the holes in one edge of each top. 🛠️



Sheet Goods. By strategically placing the outfeed supports around your table saw, you can cut large sheets of plywood or MDF with relative ease.

Building a Laminated Top

Learn the tips and techniques we used to build a dead-flat, solid-wood, laminated benchtop.

I've always been impressed by a solid-wood, laminated benchtop. It makes a strong, sturdy work surface and the top often looks as good as the furniture built on it.

Making a benchtop, like the one in the photo above, seems like a simple process — you cut up a bunch of strips and then glue them up to form a solid slab. And in practice, that's just about how it goes.

But there are a few tips and techniques you can use to break the process up into smaller, more manageable steps. And by the time you

get to gluing up the entire top, you'll be surprised at how easy it was to create a benchtop that's solid, good-looking, and as flat as can be.

CUTTING THE STRIPS

The first step in building a laminated benchtop is choosing the material for the strips. What you're looking for here is a hard, durable wood. Just about any hard wood will do. But since you're going to use quite a bit of material, cost can be a factor.

For the benchtop I built for the fold-down workstation shown on

page 22, I chose Douglas fir. It's hard and durable, so a benchtop made from it will hold up to years of use. And compared to most woods, it's fairly inexpensive. I was able to cut all the strips I needed out of three, 12-foot-long 2x10s I bought from a local home center.

Now there's a little more to this than just picking any board and ripping a few strips from it. For starters, you'll want to be a little choosy when selecting your stock.

As with any lumber, what you're looking for is straight boards with as few knots and defects as possible. So be sure to take the time to find the best pieces you can.

Once you have the lumber home, you can crosscut the material into six-foot lengths. This way, you'll have a little extra length to allow for any end checks, imperfections, or planer snipe that might show up later.

With the lumber cut to rough length, you're ready to rip the pieces to width. Since I was looking for a top about 2½" thick, I ripped my strips around 2¾" wide, as in Figure 1a. This gave me enough extra material to joint the edges flat and square, and then plane the edges smooth.

Once the strips are ripped to width, you'll be turning them on edge to glue them up. Besides a more stable top, the exposed edge grain provides a couple side benefits — a tougher surface and a great-looking benchtop (see photo).

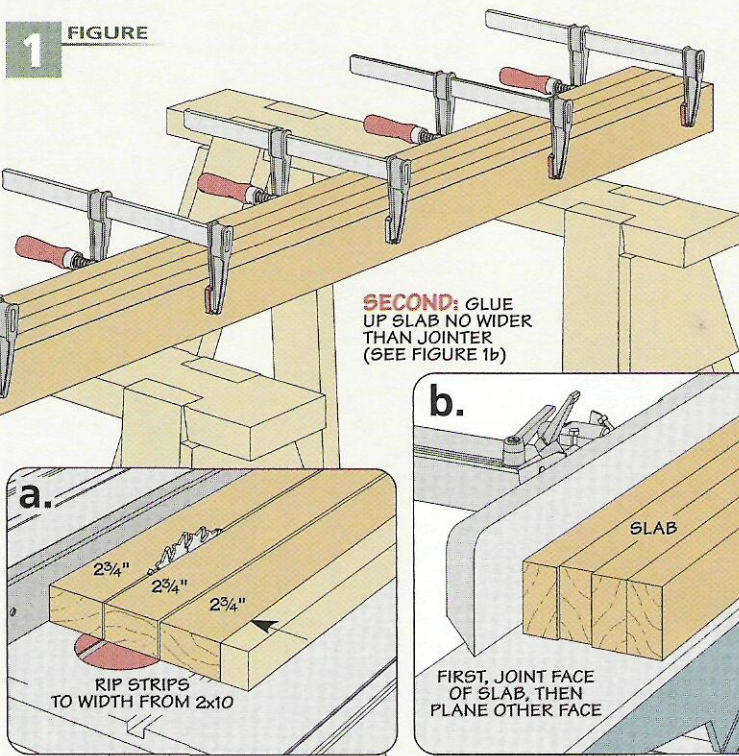

MAKE A DRY RUN

After cutting all the strips to size, the next step is to make a dry run by clamping up the strips without glue.

Why a dry run? It's the best way to discover any problems you might run into *before* you have glue all over and it's too late to do anything about it.

Since I was assembling the benchtop on sawhorses, I took some time to make sure they were in the same plane by sighting across the tops. Doing this avoids introducing any twist in the top.

Now dry clamp *four* of the strips together to form a slab. Why not the entire set of strips? Simple. By creating a narrow slab, you can easily joint one of the faces flat and smooth. Then you can run the slab through the planer to flatten it.

Note: Take the time to position the straightest (and best-looking) pieces on the outside of each slab.

GLUE IT UP

With a dry run under your belt, you're ready to glue up the slabs that will make up the benchtop.

After applying the glue and adding the clamps, make any adjustments necessary so the tops of the strips are as flush as possible. Doing this now means you'll have less jointing and planing to do later.

2 FIGURE

SECOND: GLUE UP FOUR SLABS AND ONE STRIP USING SPLINES FOR ALIGNMENT

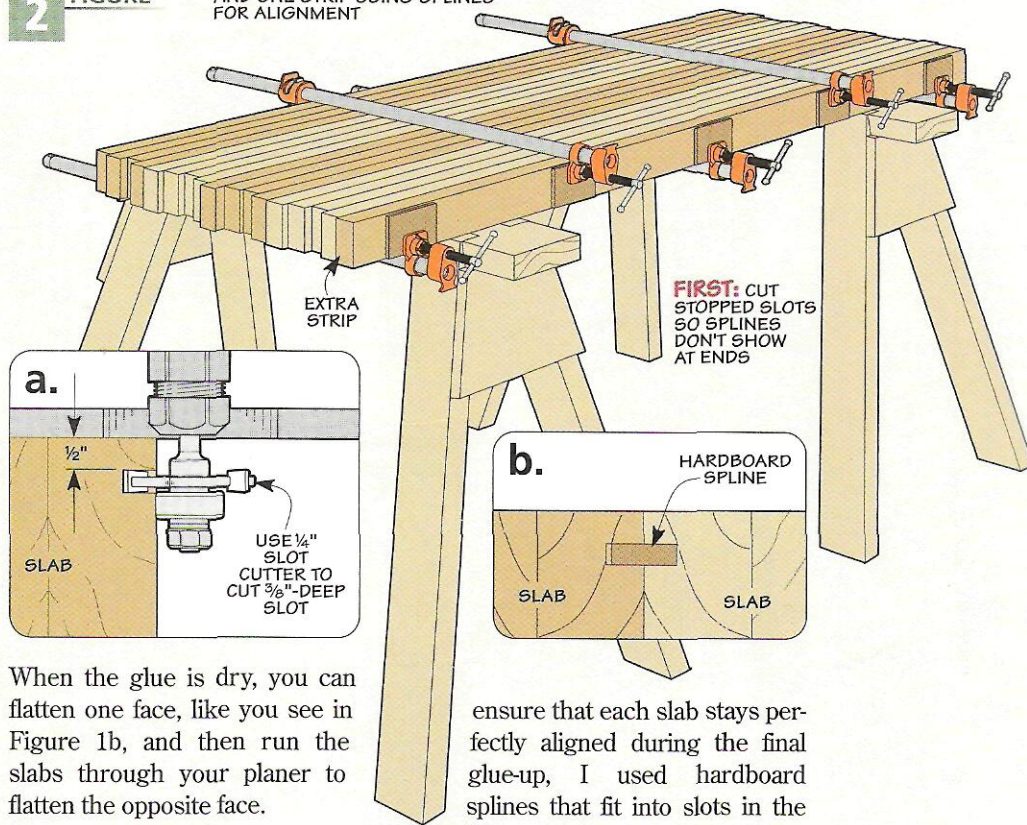

When the glue is dry, you can flatten one face, like you see in Figure 1b, and then run the slabs through your planer to flatten the opposite face.

FINAL ASSEMBLY

At this point, you should have four perfectly flat slabs about 6" wide. (Mine were about 5 3/4".)

The next step is to glue all the slabs together to form the benchtop. But there's a catch. After the glue-up, the top will be too wide to use a jointer or planer to clean it up. So to

ensure that each slab stays perfectly aligned during the final glue-up, I used hardboard splines that fit into slots in the edges of each slab (Figure 2b).

A router with a slot-cutting bit makes quick work of cutting the slots (Figure 2a). Just be sure to stop each slot far enough in from the ends of the slab so they won't show when you cut the top to final size (59 3/4").

Note: If you're building the benchtop for the workstation, you may need to add an extra strip to ensure the top is at least 24" wide.

CUTTING TO SIZE

With this procedure, I had very little cleanup to do. After a little scraping and sanding, the top was ready to be cut to final size.

The tricky part is that the top is too big to cut on the table saw. So instead, I used my circular saw and a straightedge, as shown in Figure 3.

But a circular saw won't cut all the way through the top. So first I cut as far as possible through one face, as in Figure 3. Then I flipped the top over and cut through the rest of the top, leaving just a little waste (Figure 3a). Finally, a hand-held router and a flush trim bit make quick work of removing the final waste, as in Figure 3b.

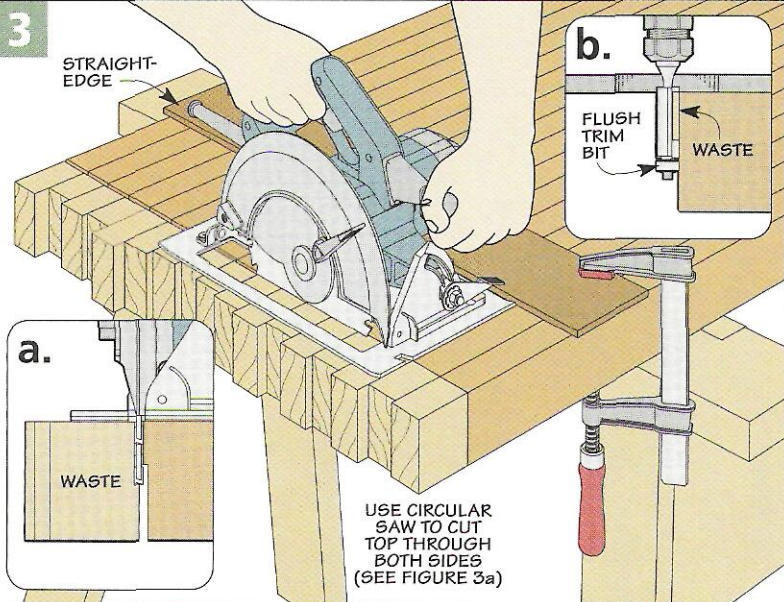

3

USE CIRCULAR SAW TO CUT TOP THROUGH BOTH SIDES (SEE FIGURE 3a)

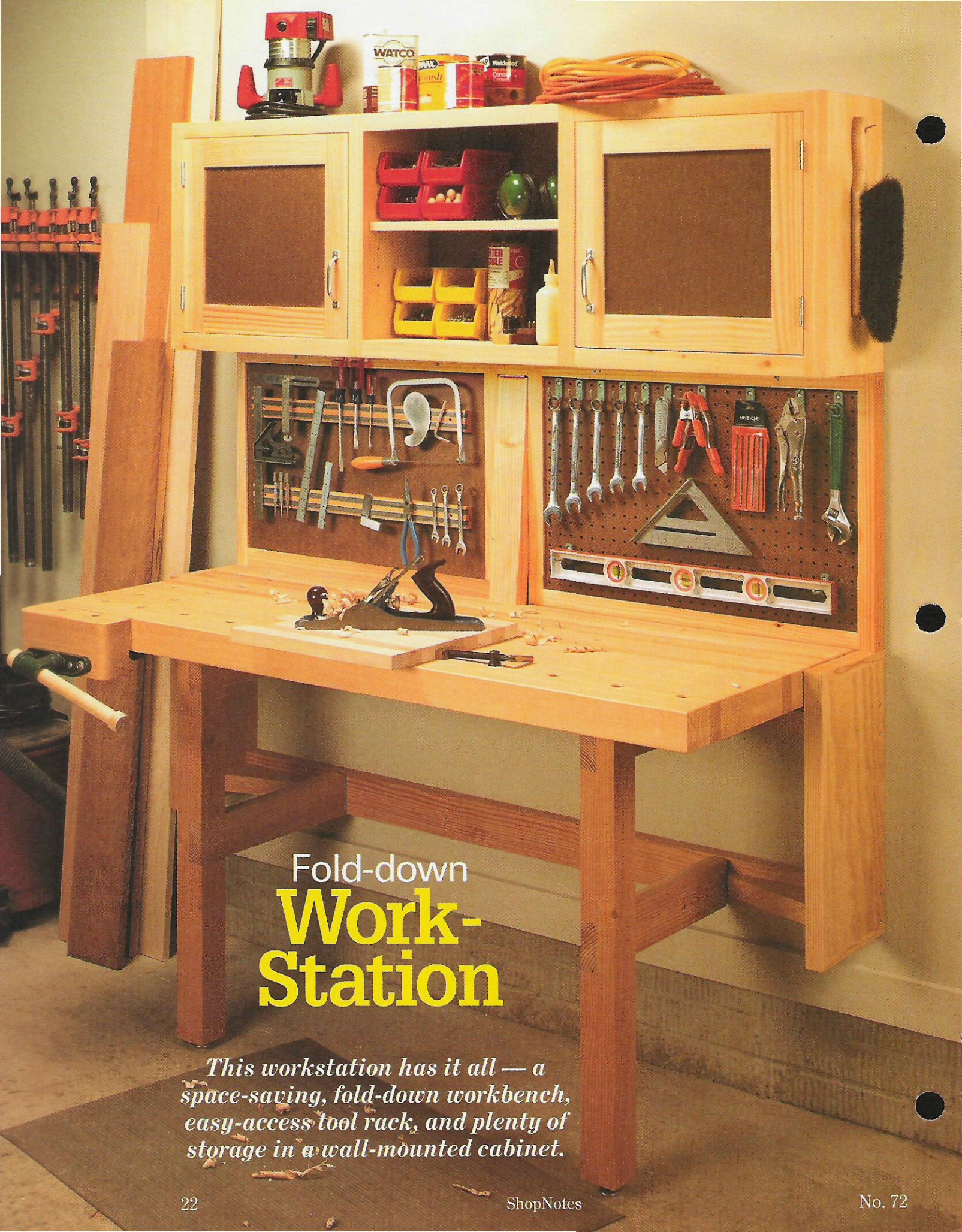

Fold-down
**Work-
Station**

This workstation has it all — a space-saving, fold-down workbench, easy-access tool rack, and plenty of storage in a wall-mounted cabinet.

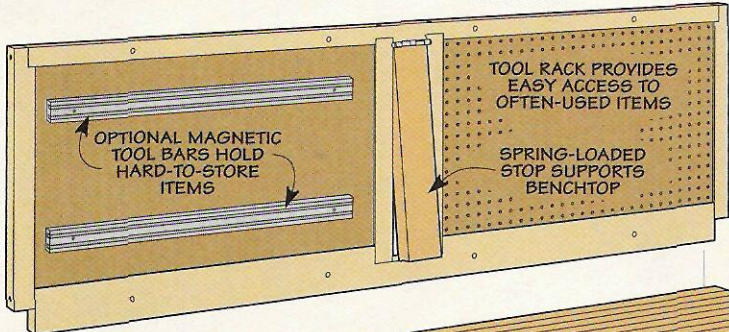
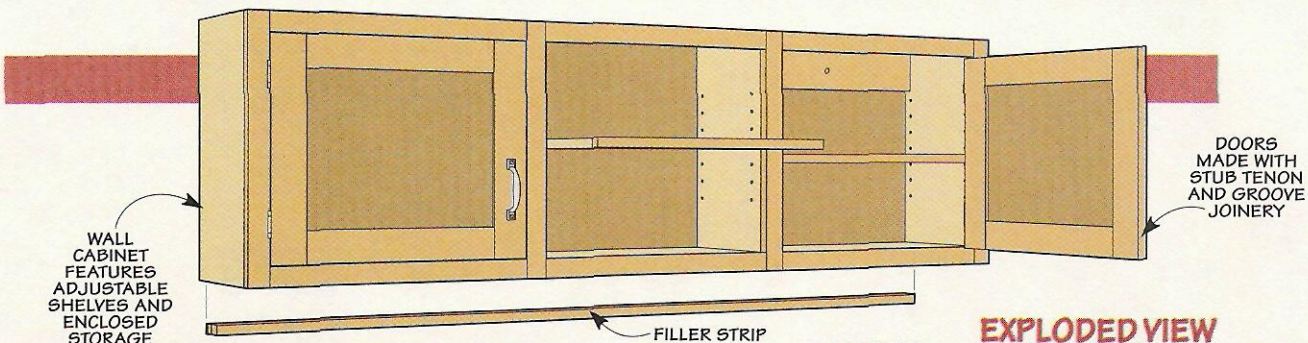

EXPLODED VIEW
OVERALL DIMENSIONS:
 63"W x 32½"D x 76"H (OPEN)
 63"W x 10"D x 76"H (STORED)

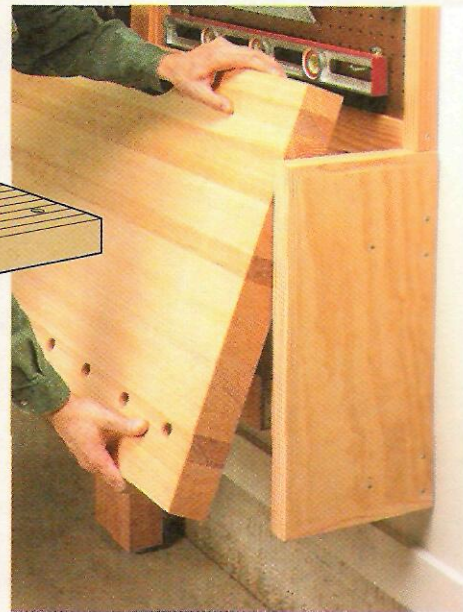

▲ **Space-Saving Design.** The top of the workbench folds down against the base to save space when you're not using it.

SOLID-WOOD LAMINATED BENCHTOP PROVIDES HEAVY-DUTY WORKSURFACE

STEEL ROD ACTS AS PIVOT PIN

STEEL PLATE TRAPS PIVOT PIN

FLANGE BEARING ACCEPTS PIVOT PIN

STOP KEEPS BENCHTOP VERTICAL IN STORED POSITION

SIDE PANELS SUPPORT BENCHTOP AND ALLOW IT TO FOLD DOWN

STRETCHERS MOUNT BASE TO WALL

HEAVY-DUTY CAST IRON VISE CLAMPS WORKPIECE SECURELY

LEGS SWING IN FOR STORAGE

LAMINATED LEGS SWING OUT TO SUPPORT BENCHTOP

ADJUSTABLE LEG LEVELERS PROVIDE SOLID SUPPORT

Materials

Workbench

A Top (1)	2½ x 24 - 59¾
B Side Panels (2)	9¼ x 18 ⁷ / ₈ - 1½ Ply.
C Edging	¾ x 1½ - 96 Rgh.
D Stretchers (2)	1½ x 3½ - 60
E Corner Braces (4)	1½ x 4 - 10
F Legs (2)	3 x 3 - 31½
G Rails (4)	1½ x 3½ - 17¾
H Spacers (2)	¾ Rgh. x 3 - 5
I Stops (2)	1 x 1½ - 2 Rgh.
J Face Block (1)	3 x 4½ - 10

Tool Rack

K Top Rail (1)	1½ x 1½ - 61
L Bottom Rail (1)	1½ x 3½ - 60

M End Stiles (2)	1½ x 1½ - 20
N Center Stiles (2)	1½ x 1½ - 19
O Pegboard Panel (1)	18 x 28 - ¼ Pgbd.
P Hardboard Panel (1)	18 x 28 - ¼ Hdbd.
Q Filler Panel (1)	17 x 27 - ¾ Ply.
R Filler Strip (1)	¼ x ½ - 3
S Benchtop Stop (1)	1½ x 2 ⁷ / ₈ - 18 ¹ / ₈

Wall Cabinet

T Top/Bottom (2)	9¼ x 62½ - ¾ Ply.
U Sides (2)	9¼ x 20 - ¾ Ply.
V Dividers (2)	9 x 18¼ - ¾ Ply.
W Back (1)	18 ³ / ₄ x 62 - ¼ Hdbd.
X Side Shelves (2)	8 x 20 ³ / ₈ - ¾ Ply.
Y Center Shelf (1)	8 x 18 ⁷ / ₈ - ¾ Ply.

Z Side Edging (2)	¾ x ¾ - 20 ³ / ₈
AA Center Edging (1)	¾ x ¾ - 18 ⁷ / ₈
BB Cleats (2)	3½ x 20½ - ¾ Ply.
CC Frame Rails (6)	¾ x 1½ - 19
DD Frame Stiles (4)	¾ x 1½ - 20
EE Filler Strip (1)	1½ x ¾ - 62
FF Door Rails (4)	¾ x 2½ - 14 ³ / ₈
GG Door Stiles (4)	¾ x 2½ - 16 ⁷ / ₈
HH Door Panels (2)	12 ³ / ₈ x 14 ³ / ₈ - ¼ Hdbd.

ShopNotes To download a free cutting diagram and hardware list for the Workstation, go to: www.shopnotes.com

GO ONLINE EXTRAS

build a folding WORKBENCH

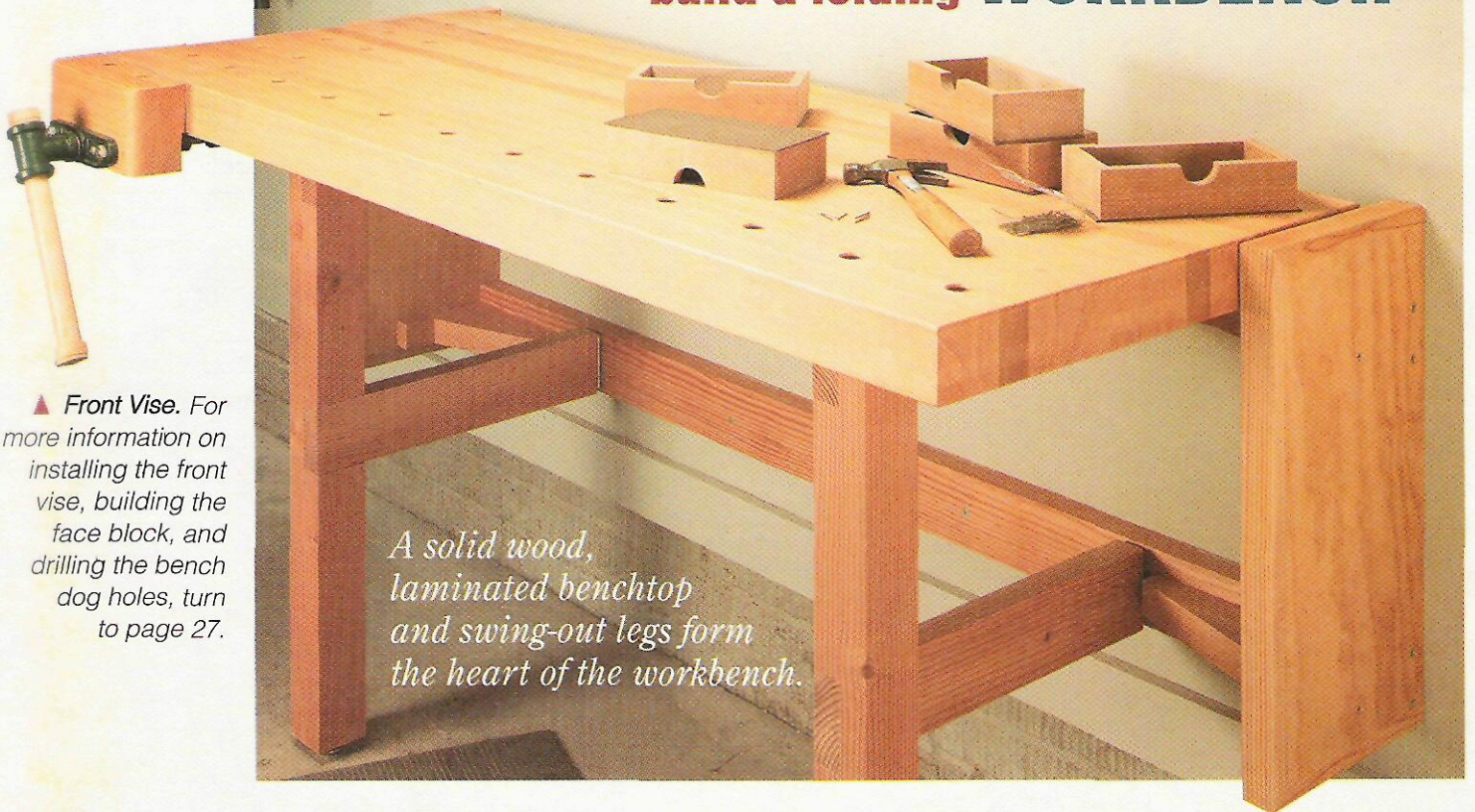

▲ **Front Vise.** For more information on installing the front vise, building the face block, and drilling the bench dog holes, turn to page 27.

A solid wood, laminated benchtop and swing-out legs form the heart of the workbench.

I started on the workbench by making the top. Why the top? A couple reasons. First, the overall dimensions determine the final size of the base. And second, you can set the top on a couple sawhorses and use it to complete the rest of the workbench.

Make the Top – The top (A) shown above is made from strips of solid wood — pretty typical for a heavy-duty workbench. To learn how I made this top, refer to page 20. Or you can make a simpler version, like the box on the opposite page shows.

Base – Once the top is complete, the next step is to build the base. You can see in Figure 1 that the base has thick, solid legs supporting the front edge of the benchtop.

What's different is that these legs swing in towards the back of the base allowing you to fold the top down. A pair of side panels and stretchers at the back of the base support both the legs and the benchtop.

Make the Side Panels –

To provide solid support for the back of the benchtop, the side panels (B) are made by gluing up two layers of $\frac{3}{4}$ " plywood and then adding solid wood edging (C).

The next thing to do is drill a counterbore in each side panel to provide a pivot point for the top. The counterbores accept flange bearings that prevent wear and tear on the side panels as you pivot the top up and down.

The key to locating the holes is to measure the thickness of your benchtop. With that measurement in hand, you use Figures 1a and 1c to locate the holes. Note: This positions

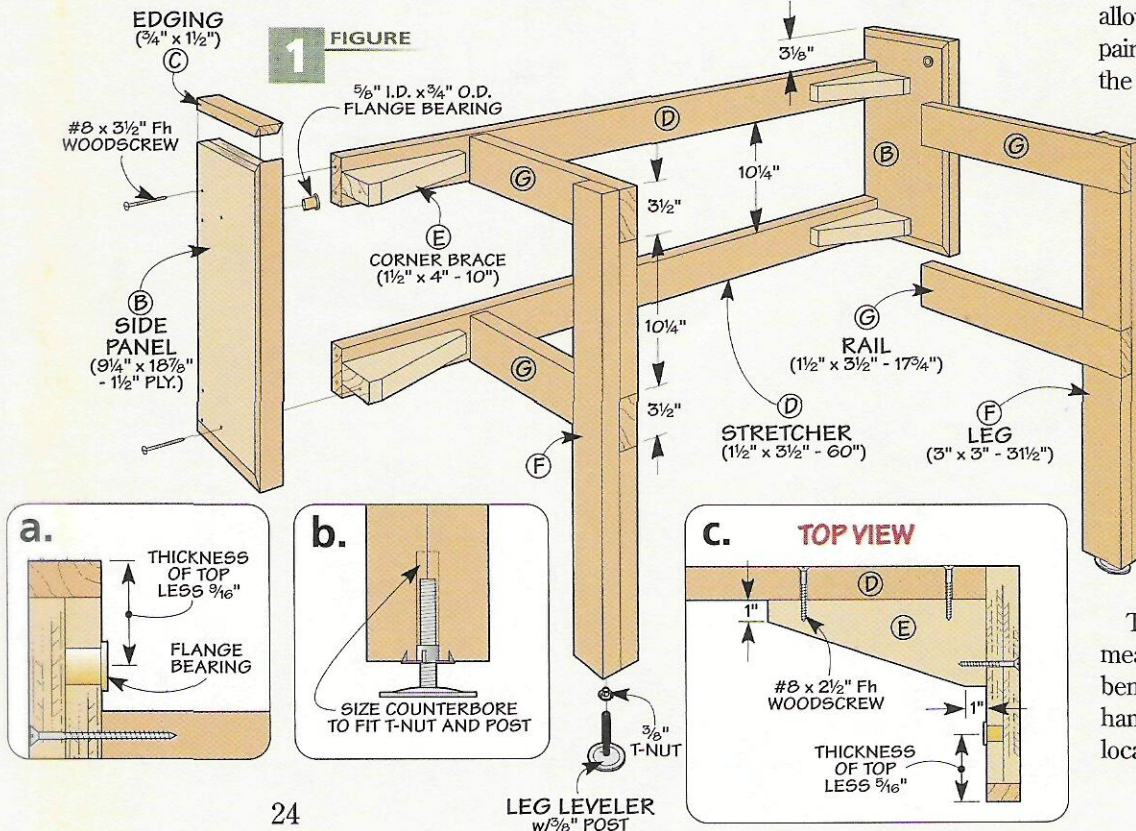

the top so that it's 1/4" above the side panels in the raised position and flush with the front edge of the panels when it's folded down.

Add the Stretchers – To connect the side panels and provide a way to attach the legs of the workbench to the wall, I added a pair of stretchers (D), as in Figure 1. The stretchers are simply screwed in place. (Don't use any glue here. You'll need to take one side panel off later so you can install the top.)

To prevent the side panels from flexing, I added the corner braces (E) shown in Figures 1 and 1c. Here again, the braces are only screwed to the side panels.

Build the Leg Assemblies – With the back complete, the next step is to build the leg and rail assemblies. The legs (F) are glued up from two pieces with a leveler installed at the bottom (Figure 1b). Then the rails (G) are cut to size and glued into dadoes and rabbets cut in the legs, as in Figure 1.

Final Assembly – To allow the legs to swing in and out, they're

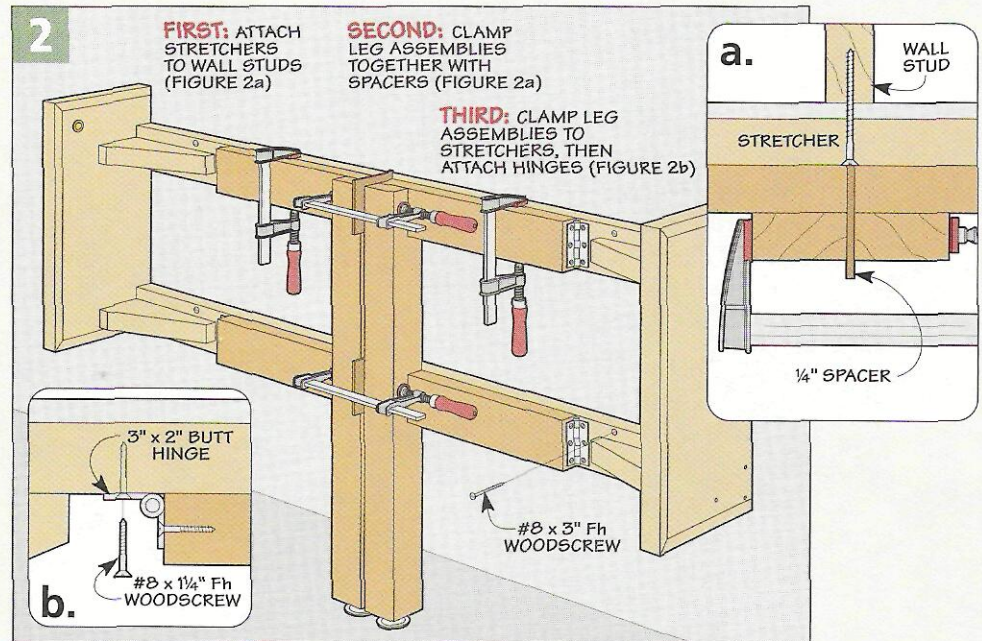

attached to the stretchers with hinges. But before you do that, you'll need to mount the side panels and stretchers to the wall. This is just a matter of screwing the stretchers to the wall studs so they're level from side to side. (I positioned the top of the side panels 35 3/4" above the floor.)

Now you can attach the leg assemblies. I found that the easiest way to do this was to clamp the two assemblies together with spacers in between them. Then you can clamp this assembly to the stretchers, as illustrated in Figures 2 and 2a. Finally, screw the hinges in place.

Make an Alternate Top

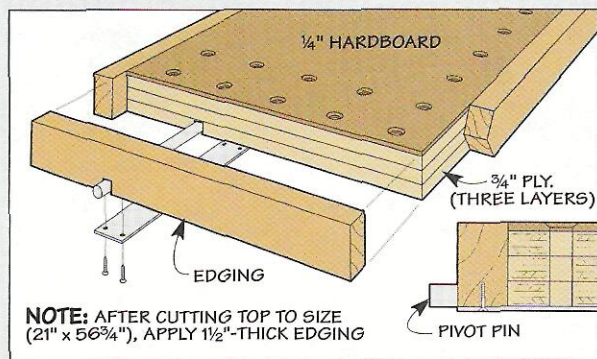

Gluing up solid wood strips to make a heavy-duty benchtop isn't the only option for the fold-down workstation. The photo at right shows an alternate top that's made from plywood panels covered with hardboard.

Built-Up Layers – In the drawing above you can see there are four layers. The bottom three layers are pieces of 3/4" plywood. Adding a final layer of 1/4" tempered hardboard provides a smooth, durable surface.

To make the top, I started by cutting each layer slightly oversized (1") in length and width. Then after

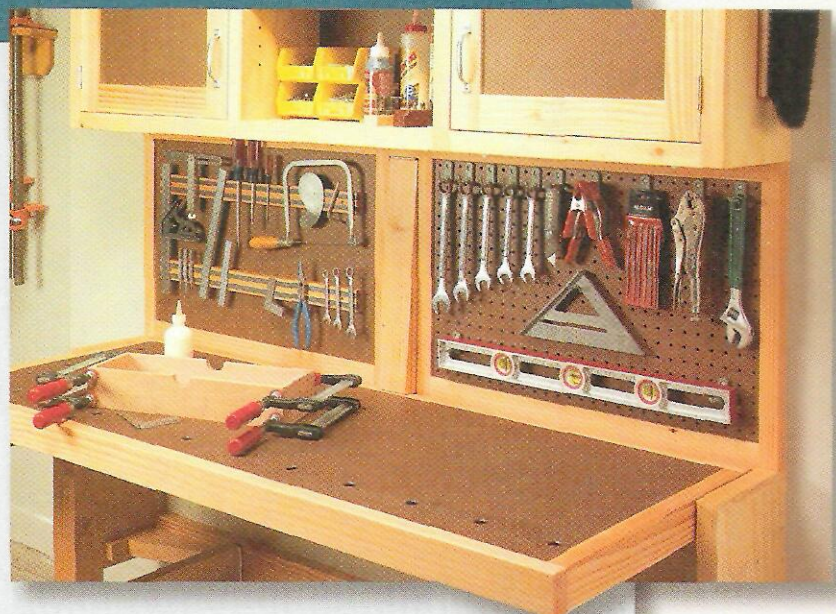

gluing all the layers together, I trimmed the top to final size (21" x 56 3/4"). Since the edges of sheet goods aren't all that tough, I covered them with strips of Douglas fir.

At this point, completing the installation of the top is identical to the laminated benchtop.

Installing the Top

With the base attached to the wall, you're ready to install the top. And regardless of which top you use, the process is identical.

Add the Pivot Pins – The first step is to install the pivot pins that allow you to fold the top up or down.

As you can see in Figure 3, each pivot pin is a 5/8"-dia. steel rod that rests in a stopped groove cut in the lower surface of the top. Each rod sticks out past the end of the bench and fits into the flange bearings installed in the side panel, as shown in Figure 3a.

To cut the grooves I used a straight bit in a hand-held router, as in Figure 3b. Then I squared up the ends of the grooves with a chisel.

A hacksaw makes quick work of cutting the rods to length so about 3/4" sticks out past the ends of the grooves. Finally, to trap the rod in place, there's a 1/8"-thick steel plate screwed to the bottom face. (I picked up both the rod and steel plate at a local home center.)

Install the Top – At this point, you're ready to ask a friend to help you install the top. Start by removing one side panel from the base. Next,

swing out the legs and set the top in place. This makes it easier to slide the ends of the pivot pins in place and then reattach the side panel to complete the installation.

Final Details – There are a couple things left to do to complete the installation of the top. The first is to add a couple *spacers* (*H*) to the bottom of the benchtop (Figure 4).

These spacers serve two purposes. First, they trap the legs and hold them in place after you swing the legs into position. And second, to level the top when it's in the raised

position, the spacers are sized to fill the gap between the top of the legs and the benchtop, as in Figure 4a.

Just be sure to locate the spacers so the legs are square to the base when they're resting in the dados.

Stop – All that's left at this point is to glue a pair of stops to each side panel, as illustrated in Figure 5. These *stops* (*I*) keep the top perfectly vertical when the top is in the stored position (Figure 5a and lower photo).

Add a Vise – Finally, if you'd like to add a face vise to your bench, check out the article on the opposite page. The vise, along with a face block and a few holes in the top, provides a variety of clamping options.

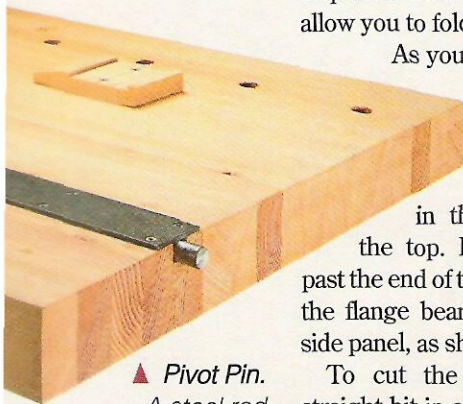
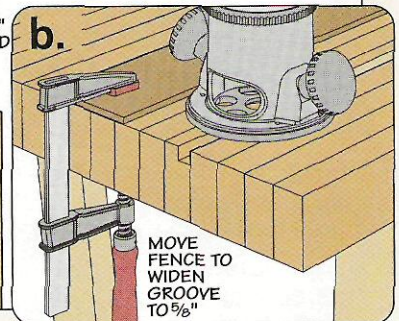
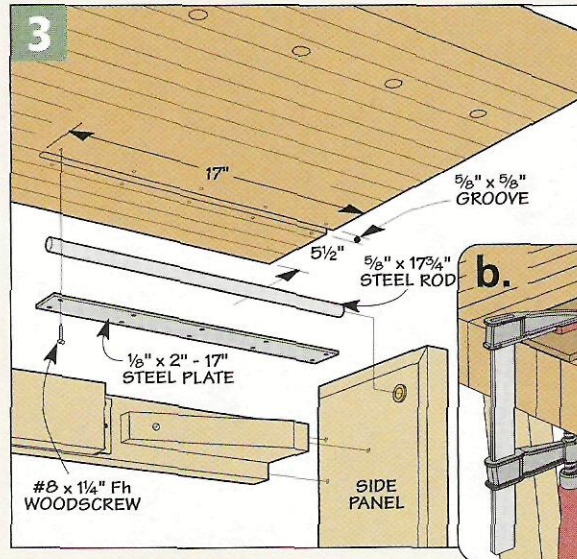
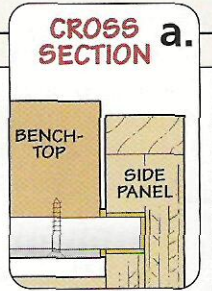

▲ **Pivot Pin.**
A steel rod trapped in a groove by a metal plate acts as the pivot pin for folding the top up and down.

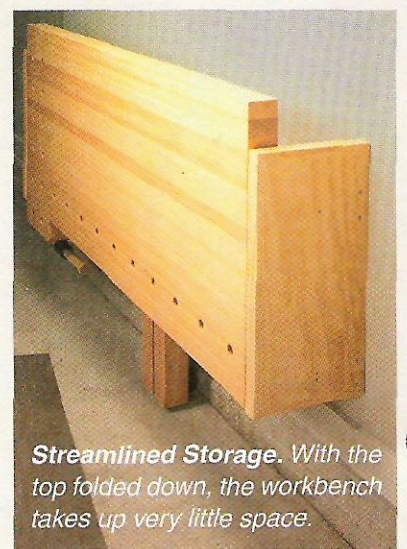
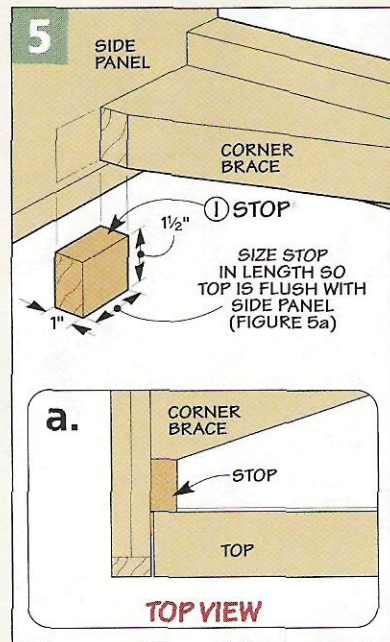
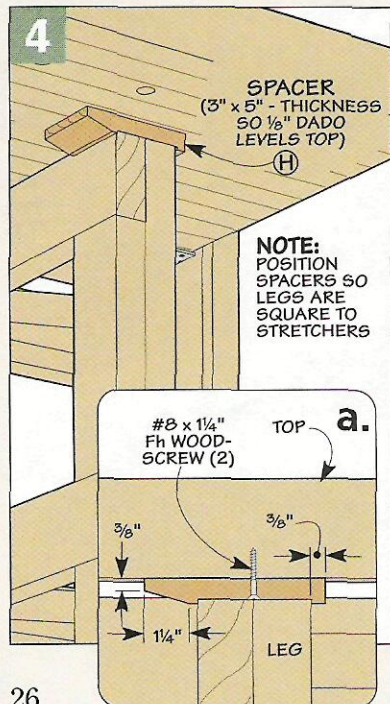

Streamlined Storage. With the top folded down, the workbench takes up very little space.

Adding a Bench Vise

To add more clamping capability to a workbench, you can add a cast iron vise. You can see the one I added to the heavy-duty workbench in the photo at right.

A face vise works great for clamping a workpiece between the jaws. But for even more options, you might want to think about drilling a set of dog holes in the top.

The dog holes allow you to use a set of bench dog accessories, with or without the

vise, to clamp a workpiece to the top of the workbench. (For more information on the vise and accessories I used, see page 35.)

Install the Vise – Installing a vise isn't difficult. In most cases, it's just a matter of bolting it in place, like you see in the drawing and details below. But there are a couple things to keep in mind as you do this.

First, you'll need to make sure that the

guide rods on the bottom of the vise don't interfere with the legs of the bench. And then, for the vise I used, I added a *face block* (J), as in the drawing, detail 'a,' and detail 'c.'

Drill the Dog Holes – With the vise in place, lay out and drill the holes for the bench dogs, like you see in details 'a' and 'b.' Just be sure the holes don't interfere with any of the vise parts underneath the bench. Finally, rout a small chamfer at the top of each hole to make it easy to insert the bench dogs (detail 'c').



▲ **Leather Faces.** Once the bench vise is installed, you can add leather to the inside faces of the vise and bench to protect and more securely clamp your workpiece in place.

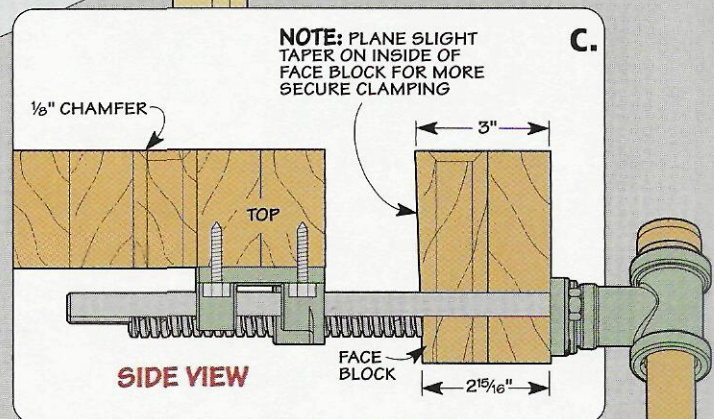
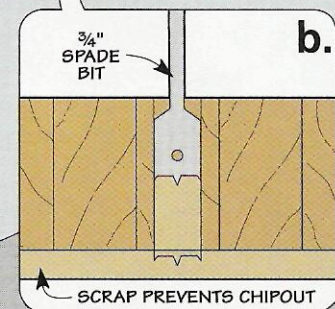
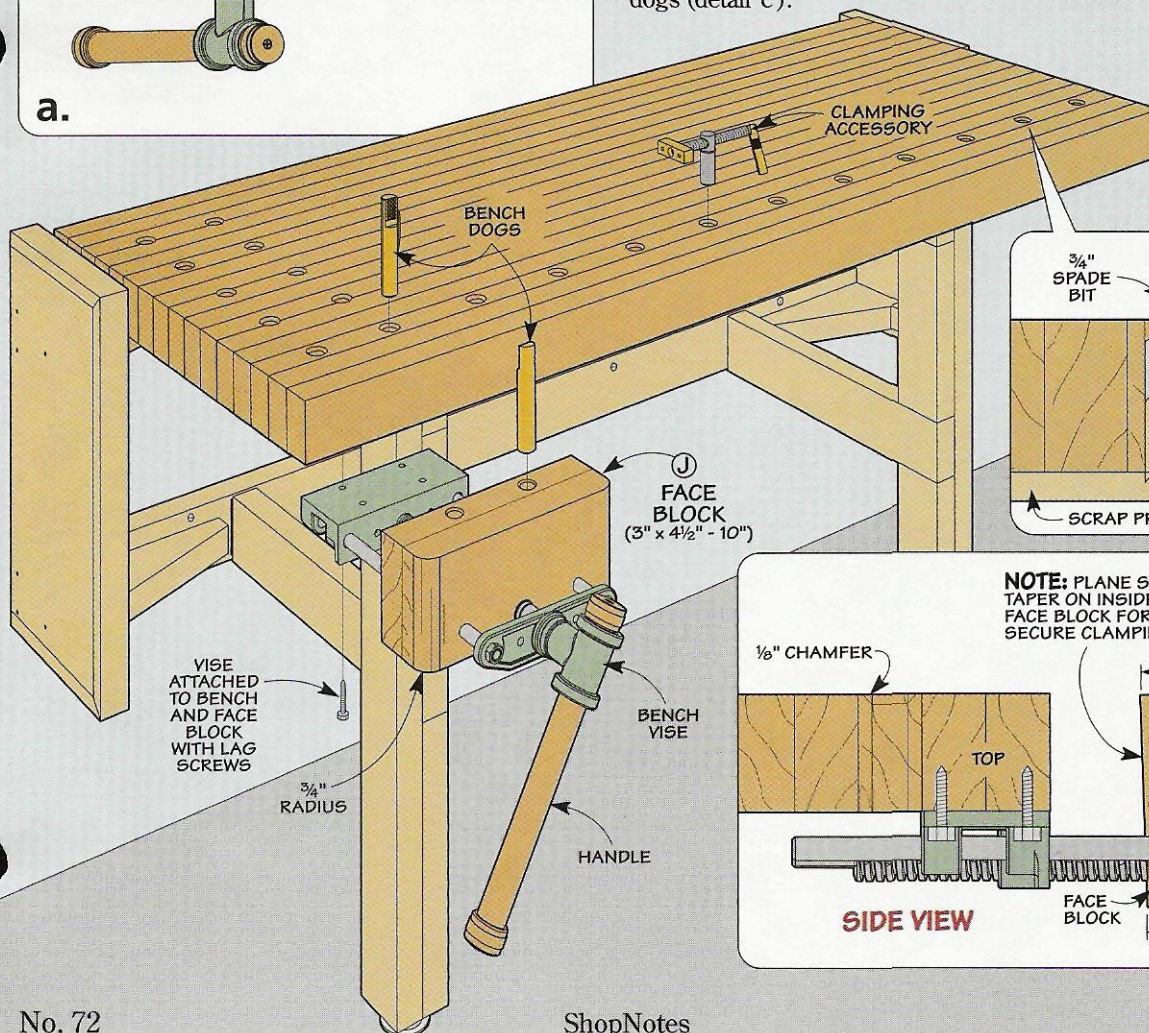
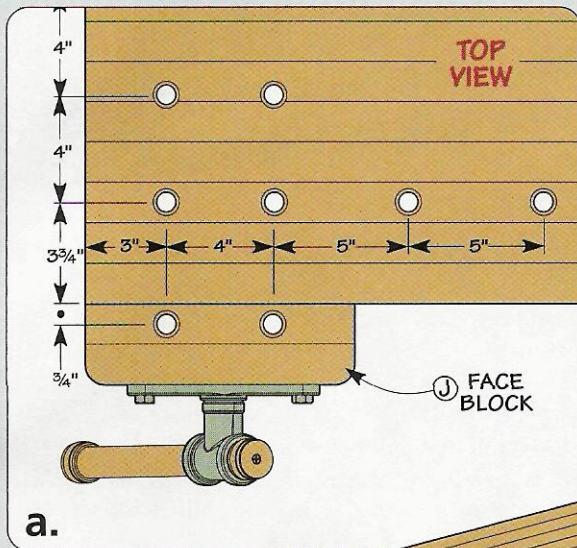

wall-mounted **TOOL RACK** with built-in stop



One of the big problems in a workshop is keeping your tools organized and within easy reach — especially around a workbench. But I solved that problem by making the wall-mounted tool rack shown above.

Besides providing a convenient storage spot for tools, there's a handy feature built into the rack — a spring-loaded stop. The stop holds the benchtop up while you swing the legs of the workbench

out to set it up, or when you're folding the legs in for storage.

Make the Frame — There's really not much to the tool rack. It starts out as a solid-wood frame made from Douglas fir. But as you can see in Figure 6, there are some things to keep in mind.

For starters, the top and bottom of the frame aren't identical. The bottom is slightly wider and shorter than the top. Once the frame is put

together, it allows the tool rack to slip down between the side panels of the base and "fill the gap" along the back edge of the workbench.

Once you have the *top rail* (K), *bottom rail* (L), and *end stiles* (M) cut to size, there's a little joinery to take care of. First, the stiles need a rabbet at one end to accept the top rail.

Then on the top and bottom rails, you'll need to cut some dados. Here, the top rail has two dados to

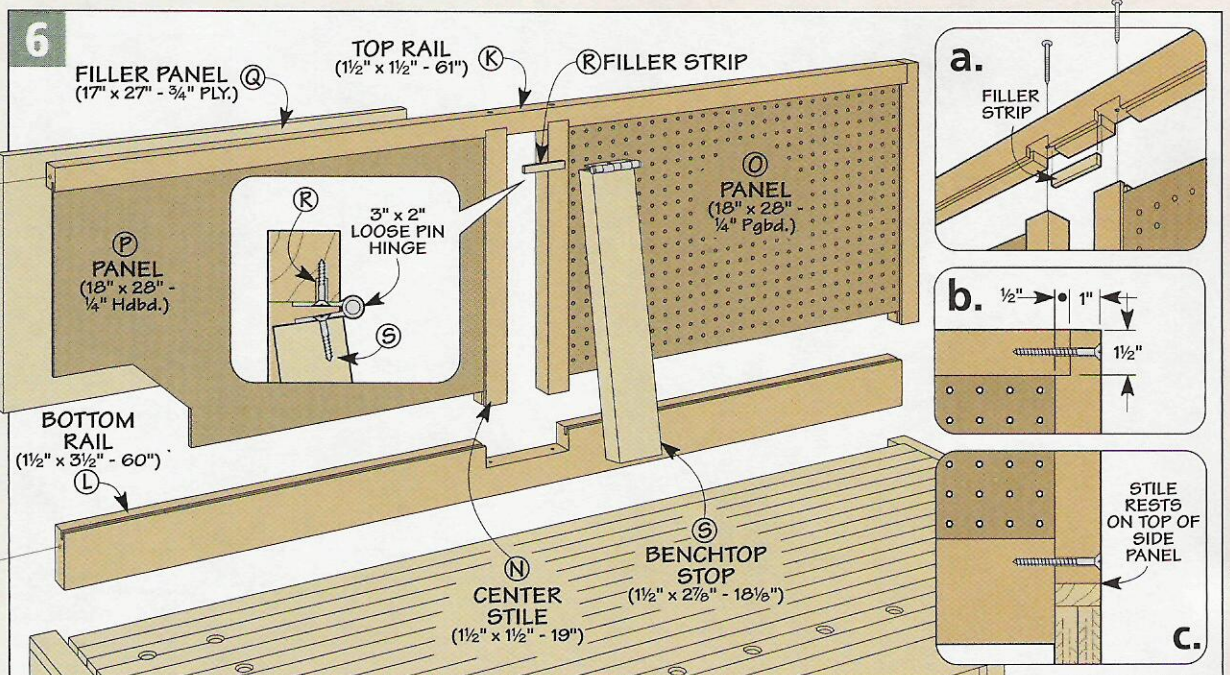
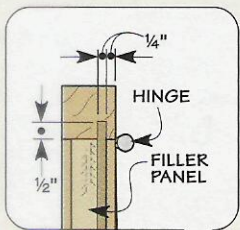

accept a pair of *center stiles* (N), while the bottom rail has a single, wide dado. The wider dado not only accepts the center stiles, but it also provides room for the end of the flip stop that's added later.

Cut the Panel Grooves – Once you've completed the dados and rabbets, all that's left is to cut a groove near the *front* edge of all the pieces (see margin detail on page 28) to accept the panels.

Frame Assembly – With the groove complete, you're ready to assemble the frame (Figures 6, 6b, and 6c). As you can see in Figure 6, there's a pegboard *panel* (O) you can use to store a variety of tools with standard pegboard hooks.

But the other *panel* (P) is just a solid piece of hardboard. After assembling the frame, I glued a *filler panel* (Q) to the back of the hardboard.

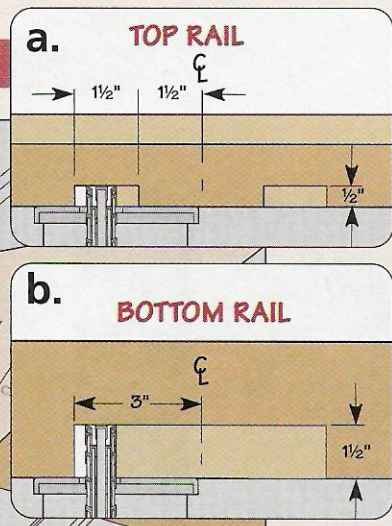
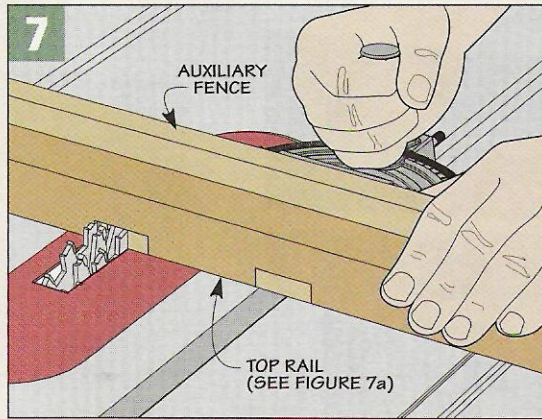

This way, you can be sure there's enough material to screw magnetic strips in place (like I did) or mount custom tool holders.

Finally, you'll need to glue a small *filler strip* (R) in the groove between the dados in the top, as in Figure 6a. This filler allows you to screw the hinge for the flip stop in place.

All that's left to do is add the *benchtop stop* (S). To learn more about how to make the stop and how it works, see the box below.

Although the tool rack keeps a lot of your often-used tools in easy reach, you can add even more storage by adding the wall cabinet featured on the next page.

Benchtop Stop

Trying to reach under the workbench to swing the legs out for use (or in for storage) is tough when you're also trying to hold up the top of the workbench. To make this easier, I added a benchtop stop (see photo).

The stop is sized to fit the opening in the wall rack. I attached it with a loose-pin hinge. This way, I could install each half of the hinge separately and then slip the pin in place.

A counterbore drilled in the back of the stop houses a spring (detail 'a') to provide hands-free operation. As you swing the benchtop up from its stored position (detail 'b'), the back presses the stop in (detail 'c') until it "pops" back out. At this point, let the top down so the stop holds it in place (detail 'd'), then swing out the legs.

When you want to fold the top down, let the stop hold the top in place as you swing the legs against the stretchers. Once that's done, all you have to do to lower the top is lift it slightly so you can press the stop past the back edge of the top. Then just lower the top.

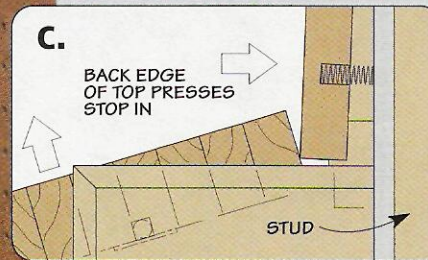
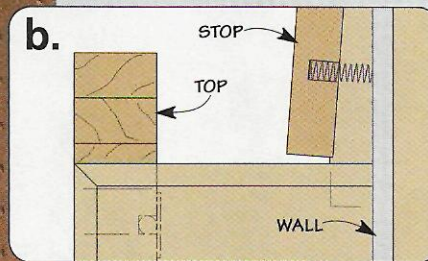
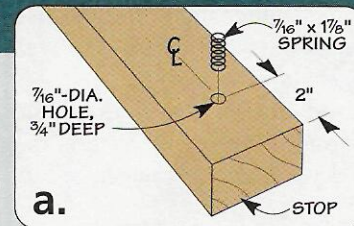
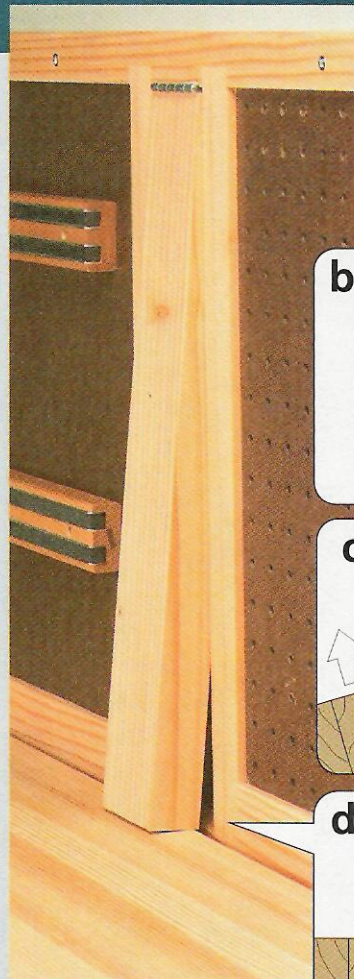

Wall-mounted Cabinet

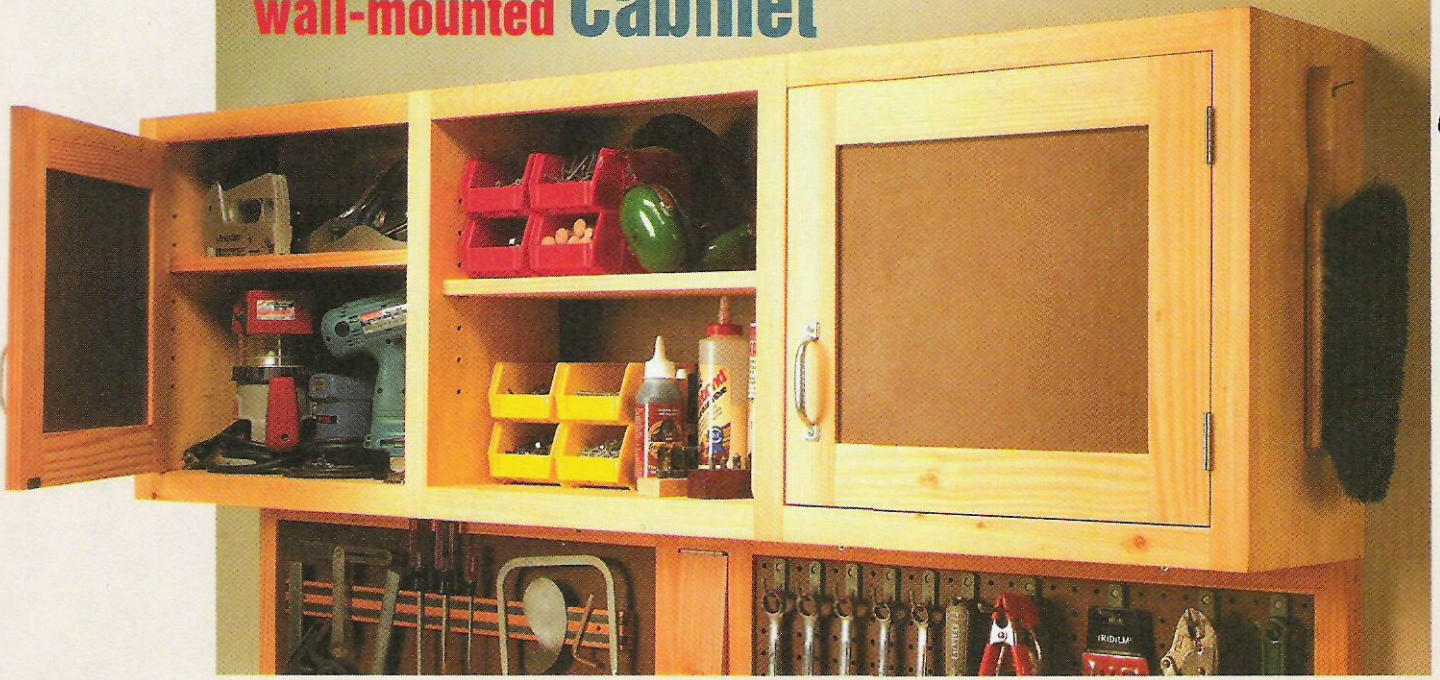

The workbench and tool rack will go a long way toward making your woodworking more productive. But I still needed a place to store power tools and other items I didn't use quite as often. So I built the wall cabinet shown above.

Build the Case – To match the low profile of the workbench in the stored position, the cabinet is only

10" deep. But that's more than deep enough to store power tools and supplies. Plus, it makes finding items a snap since they're not as likely to be hidden behind something else.

As you see illustrated in Figure 8, the case consists of a *top* and *bottom* (T), along with a pair of *sides* (U) and *dividers* (V). All these parts are made from 3/4" plywood.

Cut the Case Joinery – After cutting the plywood to size you can turn your attention to the joinery that holds the case together. In most case work, I like to use tongue and dado joints. They're quick to make and in most cases, plenty strong.

But in this cabinet, I knew I'd be storing heavy power tools — both inside and on top. So I modified the joint just a bit to create a little extra strength. If you look at Figures 8a and 8c, you can see what I did.

The tongues on the top and bottom are identical. But instead of cutting a single, narrow dado at the ends of the cabinet sides, I cut a full-size rabbet at the top and dado at the bottom. Once that was complete, I cut the narrower dadoes in each joint to accept the tongues on the top and bottom.

To hold the dividers in place, you'll need to cut matching dadoes in both the top and bottom of the case, as illustrated in Figure 8b. And rabbets along the back edge of the top, bottom, and sides accept the back.

Just be sure you check out Figure 8d first. The rabbet along the top and bottom edges is *wider* than the one in the sides. This extra width provides more gluing and nailing surface when attaching the back.

Assembly – All that's left to do before gluing up the case is to drill

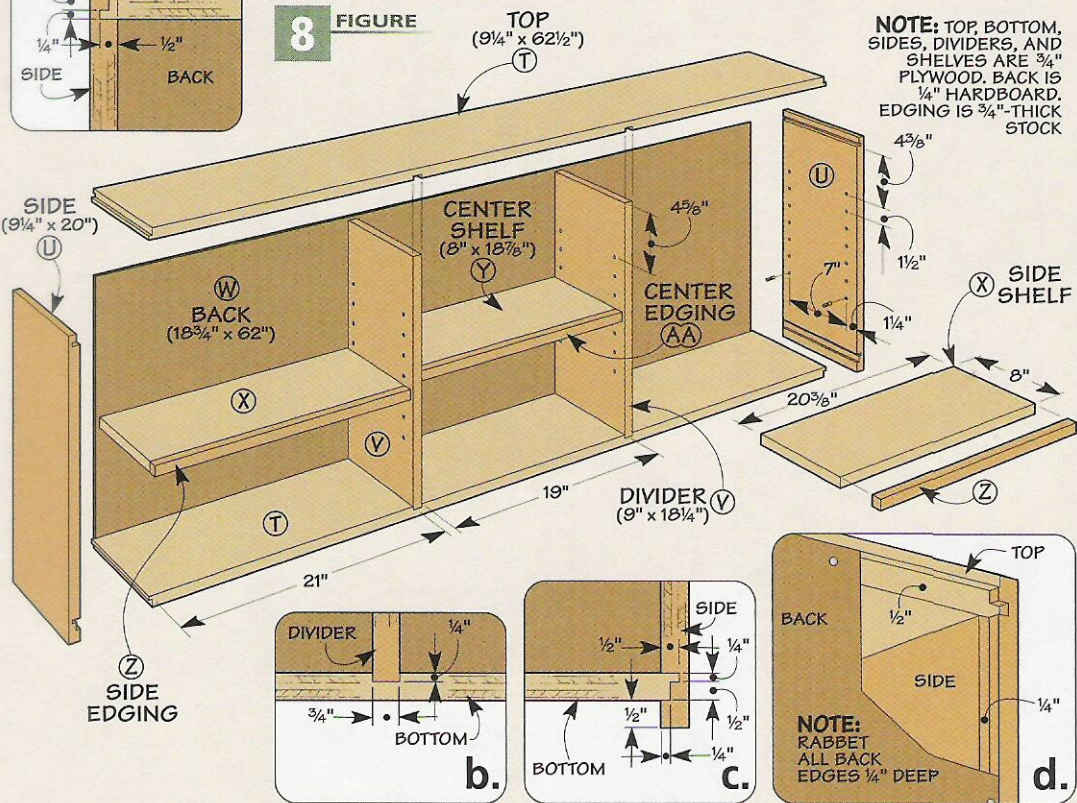
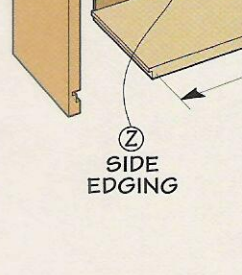
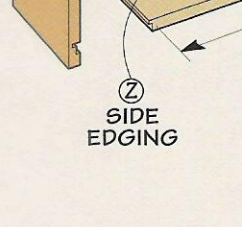
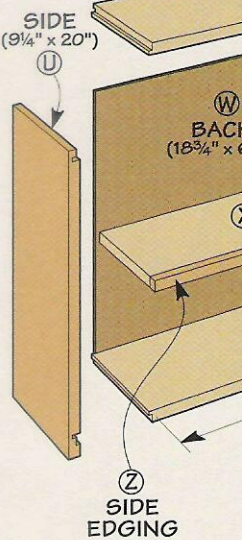
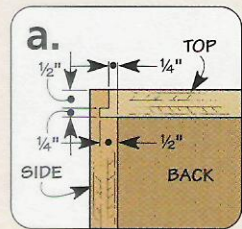

NOTE: TOP, BOTTOM, SIDES, DIVIDERS, AND SHELVES ARE 3/4" PLYWOOD. BACK IS 1/4" HARDBOARD. EDGING IS 3/4"-THICK STOCK

NOTE: RABBET ALL BACK EDGES 1/4" DEEP

holes in the sides and dividers for the pins that support the shelves. Finally, cut the 1/4" hardboard back (W) to size, then glue and nail it in place during assembly to keep the cabinet square.

Shelves & Cleats – While the glue was drying, I took a little time to cut the 3/4" plywood shelves (X, Y) to size and add some edging (Z, AA) to the front. Be sure to note that the center shelf (and edging) is shorter than the side shelves.

As I mentioned before, I was planning on storing power tools and other heavy items in the cabinet. To ensure the thin back was up to the task, I added some hanging cleats to the inside. You can see in Figure 9 that these cleats (BB) are just 3/4" plywood glued to the back in the two outside compartments.

Face Frame & Filler – Now you're ready to add the face frame. This is just a matter of cutting each face frame rail and stile (CC, DD) to size and gluing it in place.

Because the sides of the cabinet rest on the wall rack, I "filled in" the

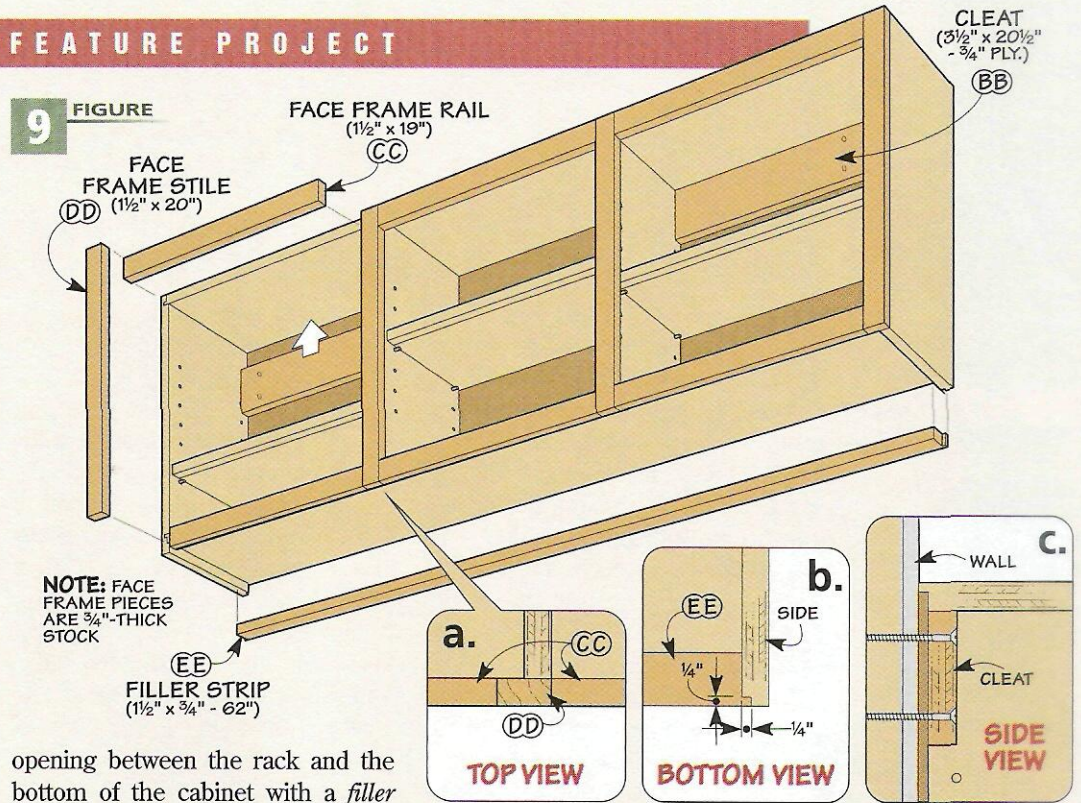

opening between the rack and the bottom of the cabinet with a filler strip (EE), as in Figures 9 and 9b.

MAKING THE DOORS

At this point, the cabinet is ready to use as is. Just hang it on the wall (Figure 9c) and load it up with all your tools and supplies. But if you

want to enclose some of the compartments, you can add a couple doors like the ones shown in Figure 10.

I started on the doors by cutting the rails (FF) and stiles (GG) to final size. (Be sure to account for the stub tenons that will be cut on the ends of the rails.) And for clearance, I allowed for a 1/16" gap all around the edges of the doors and face frame, as you can see in Figure 10a.

The next step is to cut grooves along the inside edges of the stiles and rails (Figure 10c). The groove is sized to accept the 1/4" hardboard door panel (HH). Then tongues are cut on the ends of the rails to match.

The doors are mounted to the cabinet with a pair of hinges. Instead of cutting matching mortises in both the doors and cabinets, I cut a single mortise in the door, as in Figure 10a.

An easy way to do this is on the table saw with a dado blade. Be sure to cut the mortises deep enough to maintain the 1/16" gap between the door and the cabinet frame pieces.

All that's left to do to complete the installation is to screw a handle to each door and add a magnetic catch to keep the door closed. You can see where these pieces of hardware are located in Figures 10 and 10b.

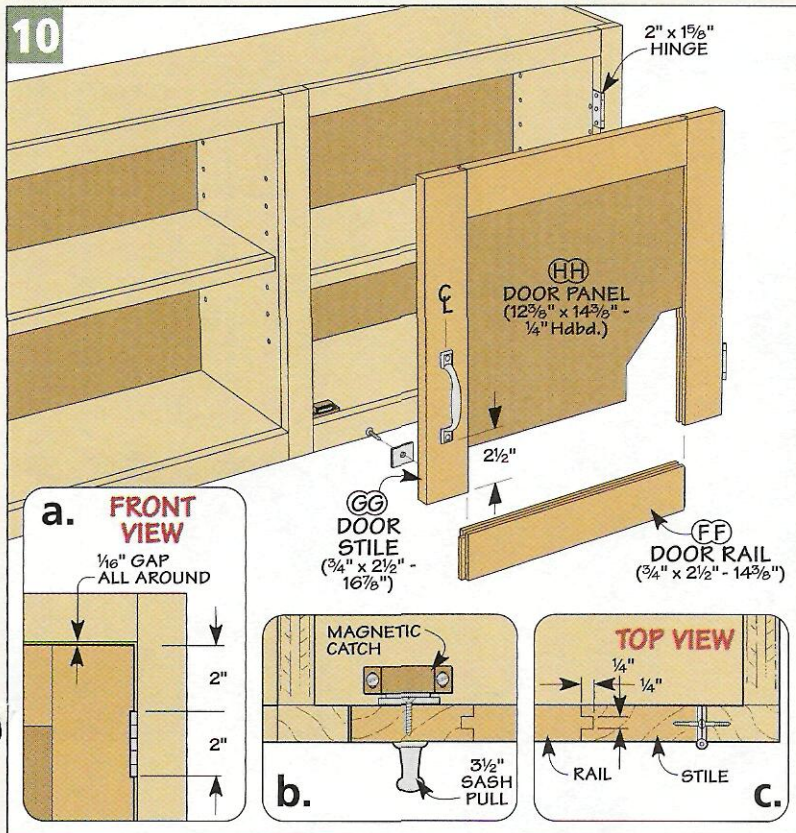

Tormek SuperGrind 2006

Sharpen every edge tool in your shop with one system? You can with the Tormek SuperGrind.

We've been using a *Tormek SuperGrind* sharpening system in our shop for several years. And it's used almost every day. So we're pretty familiar with it. But recently, *Tormek* came out with a new, improved version (#2006), and we decided to take a look at it.

THE STONE

Like the previous versions of the *Tormek*, the heart of the system is the grinding stone you see in the photo below. It's 10" in diameter, almost 2" wide and rides in a water bath. This bath not only keeps the tool cool, but it washes

away grinding waste to prevent the wheel from glazing over.

This 220-grit stone makes quick work of grinding and shaping any size or type of tool quickly. Plus, it gives a good, serviceable edge.

The one feature I really like about this stone remains the same. You can change from 220-grit to 1000-grit for an even finer edge — without changing the wheel. But more on that later.

THE TOOL REST

If the stone is the heart of the system, then the brains would have to be the tool rest. This F-shaped rest fits into either of the two mounts on the base of the machine.

The tool rest adjusts up and down (or in and out) to set the tool at the correct angle. But what's really nice is the latest version of the rest features a threaded shaft and nut, like you see in photo A.

The nut acts like a microadjust so you can adjust the tool rest with precision. With the old tool rest, I felt like I had to have three hands to accurately set the grinding angle.

Note: If you already have a *Tormek*, you can buy a replacement rest from the sources listed in the margin on the opposite page.

USING THE TORMEK

Before you start sharpening a new chisel or plane iron, it's a good idea to flatten the back. With the *Tormek*, that means a few minutes working the back of the tool on the outside face of the stone, like you see below.

Once the back is flat, you can fit the tool into the straight edge jig that comes with the basic *Tormek* system.

The straight edge jig will handle most chisels and plane irons. You can see it holding the chisel in the bottom of the photo at left. A pair of stops on the jig ensures that the edge will be square to the stone when you slip it onto the tool rest.

I typically set the rest so the stone matches the existing bevel angle on my tool. But if you'd like to regrind



▲ *Flattening the Back.* Unlike a typical stone, you can use the *Tormek* to flatten the back of a tool.

the tool to a different bevel angle, you can use the AngleMaster shown in the photo at right.

With this handy gauge, you can check an existing angle or set the tool rest for a new one. And as the wheel wears over time, you can adjust the AngleMaster to compensate.

At this point, sharpening a tool is just a matter of sliding the jig (and tool) back and forth across the stone (photo B). Even though the stone moves at a slow 90 RPM, I'm always surprised at how fast I can grind a new edge, or sharpen an existing one.

To put an even finer grind on my best chisels and plane irons, I "regrade" the stone as I mentioned earlier. To do this, you'll need one of the optional accessories — the stone grader (see the box below).

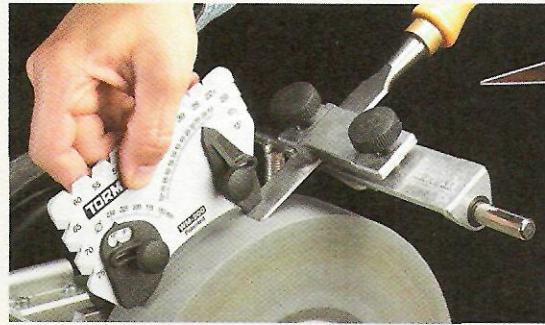

◀ **Set the Angle.** With the AngleMaster, you can verify (see inset) and set the sharpening angle perfectly.



◀ **Honing.** After applying honing compound (see inset), the leather wheel makes quick work of polishing the edge.

HONING

Although the tool is extremely sharp as is, I like to hone the edge on the leather wheel. To do this, you don't even have to remove the tool from the jig. Simply remove the tool rest and remount it so you're honing away from the edge.

After applying some honing compound to the wheel (see inset photo just above), putting a mirror finish on a tool takes a few seconds.

ACCESSORIES

The basic system will allow you to sharpen all your chisels and plane irons. But to take advantage of all that it has to offer, there are a wide range of accessories too numerous to mention. The sources listed at right can supply additional information. But to make full use of the *Tormek* right out of the box, be sure to get the accessories mentioned in the box below.

IS IT WORTH IT?

As I mentioned earlier, the basic system can sharpen chisels, plane irons, and other straight edge tools — at a cost of about \$400. The individual accessories range from \$12 to over \$150.

Is it worth it? For a system that will handle just about everything, and give you a perfect edge, I think so. That's why we use it in our shop. 🛠️

Maintaining the Stone

Even though the basic *Tormek* comes with everything you'll need to get started, there are a couple "must-have" accessories you'll want to get so you can keep the stone in sharpening "shape."

Stone Grader – The first is the stone grader in the photo at right. As its name implies, the stone grader is used to change the grade, or grit, of the stone.

To use it, you hold the grader against the turning stone for 15 to 20 seconds. The smooth side of the grader will "change" the stone to 1000-grit. And the rough side is used to convert it back to 220-grit.



The stone grader will ensure the stone is smooth and at the desired grit. Unfortunately, it doesn't guarantee that the stone is flat.

Stone Truing Tool – For a perfectly flat grinding surface, you'll need another must-have



accessory — the stone truing tool shown in the photo above.

The truing tool fits on the tool rest and has a diamond tip that makes quick work of resurfacing the stone so it's not only flat, but perfectly parallel to the tool rest.

Sources

Rockler
www.rockler.com
800-270-4441

Sharp Tools USA
www.sharptoolsusa.com
800-872-5489

Tormek
www.tormek.us
800-5-TORMEK (USA)
877-2-TORMEK (Canada)

Woodsmith Store
800-835-5084

Got a great idea? Get a Patent

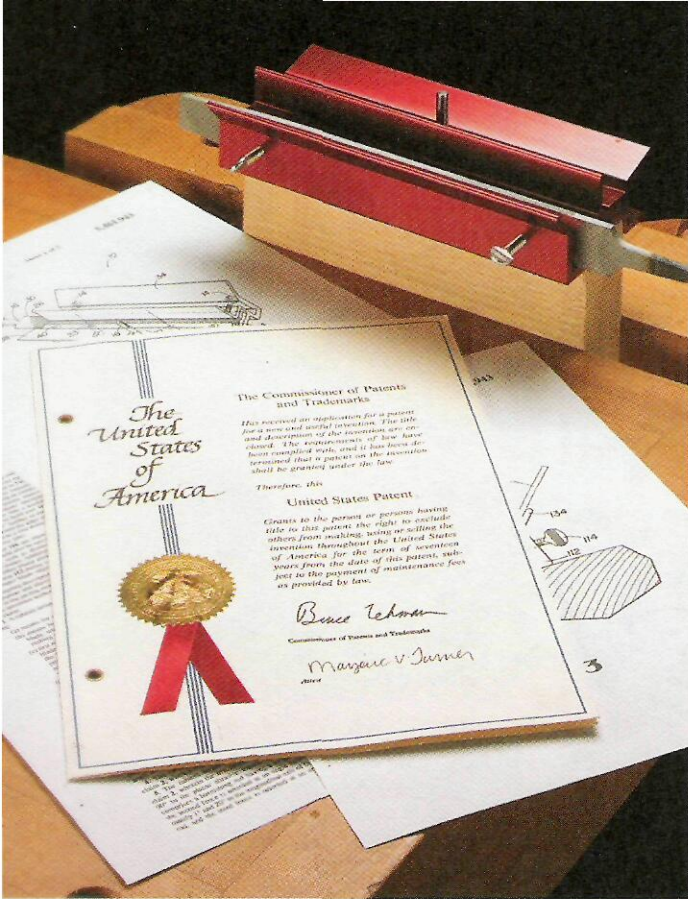

▲ **Patent.** If you're granted a patent for your invention, you'll receive a handsome certificate similar to the one shown here.

Let's say you've got a great idea for a new woodworking tool or product. If you're like most people, you probably think the first step is to get your idea patented. But what does this entail? Here's a quick look at what's involved in getting a patent.

What is a Patent? – A patent is a legal document issued by the United States government that grants an inventor the exclusive right to manufacture and sell an invention. It provides you with certain legal protections so that someone else can't come along and "steal" your idea.

There are actually two distinct types of patents. *Design patents* cover the look or appearance of an article being manufactured. But if you have an idea for a new and original invention (like a tool or jig) a *utility patent* is what you'll want. Utility patents are currently good for 20 years.

Obtaining a Patent – Patents are issued by the United States Patent and Trademark Office. But there's a whole lot more to obtaining a patent than simply filling out a form and sending in a check. To start with, you have to do a *patent search* to prove to the patent

office that your idea is new and original. This involves searching through past patents to see if anyone has ever patented an idea similar to yours. If you apply for a patent for an invention that has already been patented, your application will be denied and you will forfeit your application fee.

How do you conduct a patent search? For starters, you can go to the official website of the U.S. Patent Office (www.uspto.gov). There you will find all utility patents from 1976 and later sorted into classes and subclasses to make searching a little easier. To do a more thorough search, you will need to visit the patent office in Arlington, Virginia or a Patent and Trademark Depository Library. (There's one in every state.)

Patent Agent – Although you can do the patent search work on your own, you will probably find it more expedient to hire a *patent agent* or a *patent attorney* to handle this aspect of the process. Patent agents and attorneys are skilled in conducting patent searches and can help you to

A patent provides certain legal protections so that someone can't come along and "steal" your idea.

avoid any pitfalls in your search. (Patent agents typically charge less than patent attorneys, but they cannot represent you if you have to defend your patent in a court of law.)

It's also a good idea to hire a patent agent or attorney to help you complete the patent application. Like most legal documents, patents have a "language" all their own. If you don't do a good job of wording the patent, it may be possible for someone to come along and find a loophole that allows them to copy your idea without actually infringing on your patent.

Patent Drawings – As a part of your patent application, you'll have to submit several detailed drawings of your invention. These drawings have to follow certain guidelines and formats in order to be acceptable to the patent office. This is one area where it's best to hire a professional illustrator who specializes in patent drawings and is well versed on the requirements of the patent office. Your patent agent should be able to recommend a qualified illustrator.

Cost and Time – If you've thought about getting a patent, you've probably wondered about the cost. For a utility patent, the application and issuance fees are about \$1,000. If you include the cost of hiring a patent attorney and patent drawings, you can expect to spend around \$7,500 to \$10,000.

In addition to the financial expense, you'll also need to have a good deal of patience. Currently, the average wait from the time an application is filed to the time a patent is issued is two years. But this doesn't count all the time that goes into the application beforehand.

Realistically, you could be looking at several years before your invention is patented and in full production.

Finally, be aware that having a patent isn't a guarantee that someone won't still try to copy your idea. Even if you are granted a patent for your invention, it's up to you to defend your patent against infringements. This may mean spending substantial amounts of money in attorney's fees and lawsuits to go after someone who violates your patent.

Is It Worth It? – You might be wondering if getting a patent is worth all the expense and hassle. In some cases, the answer is clearly, "Yes." But it definitely helps to talk to as many experienced professionals as possible before actually getting started. ▲

Sources

Fold-Down Workstation

■ You'll find most of the hardware you need for the fold-down workstation on page 22 at the local hardware store.

Face Vise – If you want to add a vise to the front of the workbench, you might be able to find a suitable one at the hardware store or home center also. But if not, you can

order the one we used by giving *Lee Valley* a call. Their number is listed in the margin at right.

The part number to ask for is 70G08.01. Since the vise doesn't come with a handle, you'll need to make your own. Or you can simply order one. The part number for the handle is 05G12.03.

Magnetic Strips – To keep hard-to-store items in easy reach on the tool rack, you can make custom tool holders or add a pair of magnetic strips like I did. Here again, *Lee Valley* has a couple different types of magnetic strips available. The part number for the 24"-long strips we used is 93K75.24.

Online Extras

■ If you don't have access to the internet, we'd be happy to mail a copy of the workstation cutting diagram and hardware list to you. Send a self-addressed, stamped #10 envelope to:

ShopNotes No. 72
Online Extras
P.O. Box 842
Des Moines, IA 50304

Belt Sander Hardware

■ The belt sander project on page 6 requires an assortment of hardware. You should be able to find most of it at your local home center. But there are a few items that you might find easier to order.

Bearings – To provide solid support for the rollers, we used flanged ball bearings (RF81812PP). If you have trouble finding them, you can order them through *McMaster-Carr* by asking for the bearings as part number 6384K361.

Knobs – The only other hardware you'll need for the belt sander are the three different adjustment knobs.

You can order all three knobs from *ShopNotes Project Supplies* (see box below). Ask for one each of part numbers 1065530 and 1065526, and two of part number 1065207.

Rockler also carries a 5-star knob as part number 23820. Other sources listed in the margin carry similar knobs.

Rust Removal

■ Most of the supplies needed to remove rust by electrolysis are common items. The washing soda is available in the laundry detergent area in many grocery stores. If you

can't find it, ask the manager to order it for you from *Arm & Hammer* (UPC 33200-03020).

Finally, the 3M finishing pads (10144NA) were available at a local home center.

Table Saw Outfeed

■ There isn't much hardware required to build the table saw outfeed system on page 16. All you'll need is a set of levelers and draw catches, some T-nuts, and a few table pins.

We ordered the 4"-long levelers from *Lee Valley* (01S06.04) and picked up the draw catches at a local hardware store. Finally, we ordered the table pins (21253) from *Rockler*. 

MAIL ORDER SOURCES

Similar project supplies may be ordered from the following companies:

Rockler
800-279-4441
www.rockler.com

Bench Vises, Levelers, Table Pins

Reid Tool
800-253-0421
www.reidtool.com

Knobs, Levelers

McFeely's
800-443-7937
www.mcfeelys.com

Knobs

Lee Valley
800-871-8158
www.leevalley.com

Bench Vise & Handle, Knobs, Levelers, Magnetic Strips

Woodsmith Store
800-835-5084
Bench Vises, Knobs

SHOPNOTES PROJECT SUPPLIES

To order back issues or a hardware kit from *ShopNotes Project Supplies*, please use our toll-free order line, see below. It's open Monday through Friday, from 8 AM to 5 PM Central Time. Before calling, please have your VISA, MasterCard, Discover, or American Express card ready.

If you would prefer to mail in an order, please call the toll-free phone number below for more information concerning shipping charges as well as any applicable sales tax.

1-800-347-5105

ShopNotes

on the web

- "Online Extras" - Plans, Patterns, & More
- Over 100 Woodworking Tips Online
- Visit Our Woodworking Shop Tours Gallery
- Project Plans You Can Download
- Catalog of Project Kits, Tools, Jigs, & Plans
- Forums for Woodworking, Tools, & Classifieds
- Links to Other Woodworking Sites
- Order *ShopNotes* & *Woodsmith* Back Issues

www.shopnotes.com

Online Customer Service

Click on Subscriber Services at www.shopnotes.com

- Access your account status
- Change your mailing or email address
- Pay your bill
- Renew your subscription
- Tell us if you've missed an issue
- Find out if your payment has been received

Scenes from the Shop

Belt Sander. Clamp this ► shop-built belt sander to your drill press table to easily sand miters or the edges of a workpiece. Detailed plans can be found on page 6.

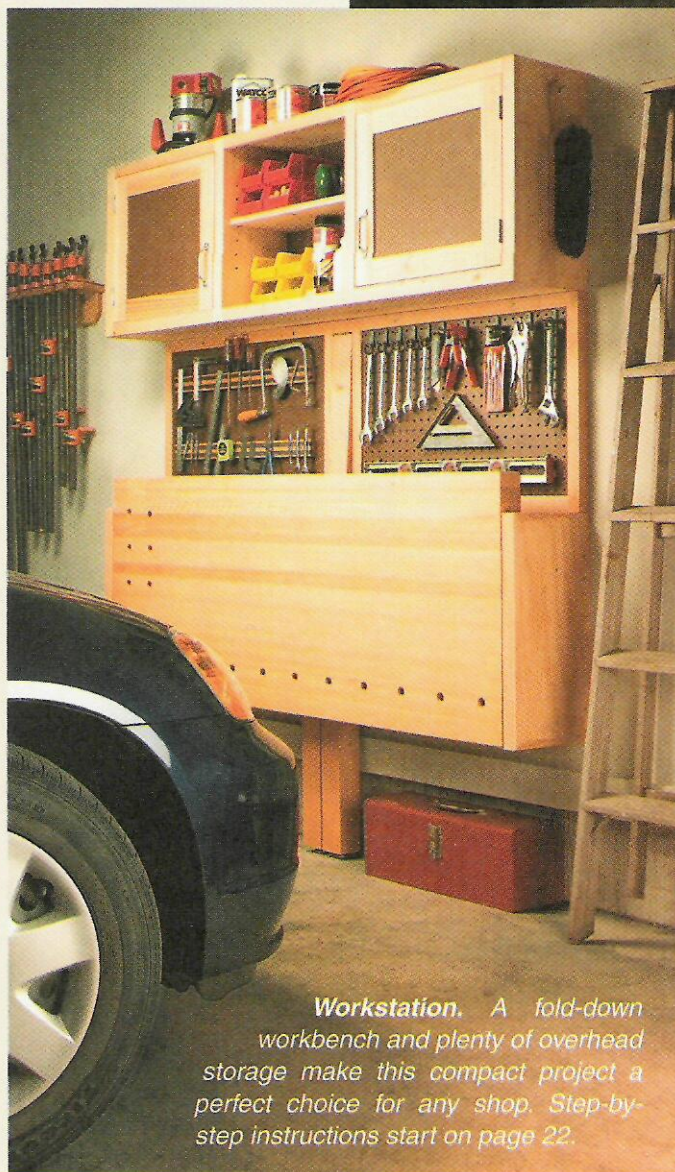
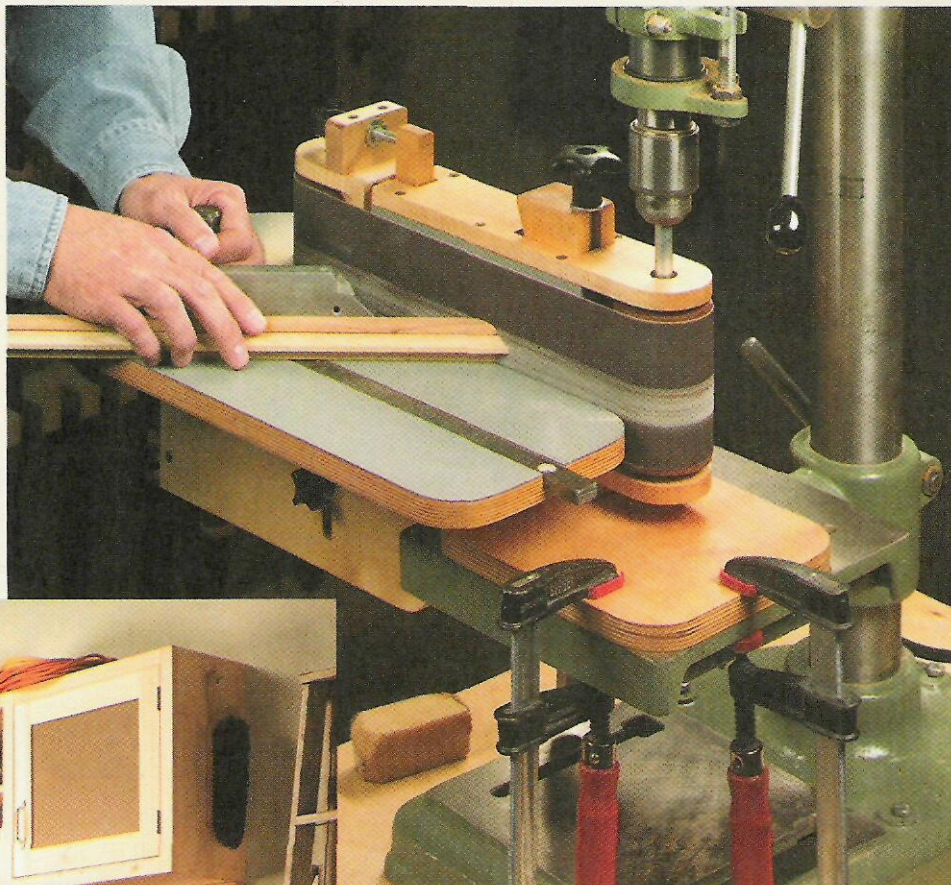

Workstation. A fold-down workbench and plenty of overhead storage make this compact project a perfect choice for any shop. Step-by-step instructions start on page 22.

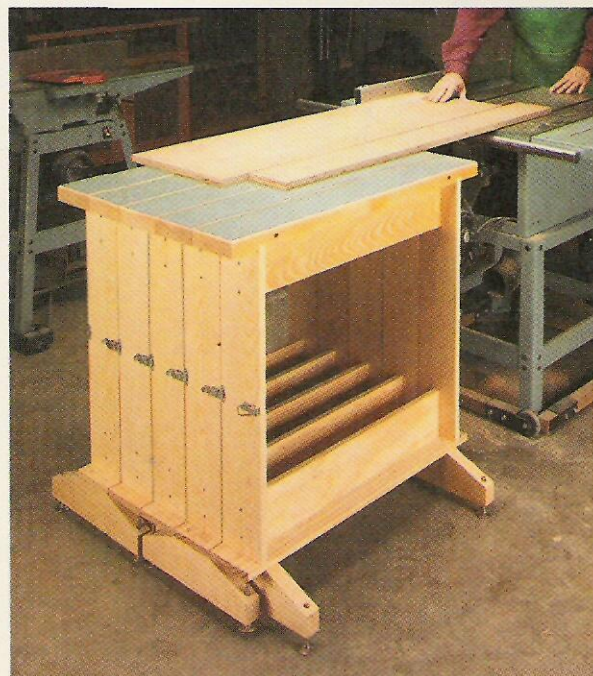

▲ **Outfeed Table System.** Fastened together, the individual units of this modular system provide a large outfeed table for your table saw. Easy-to-follow plans begin on page 16.



ShopNotes Cutting Diagram

Fold-Down Workstation

Hardware

- (2) $\frac{5}{8}$ " I.D. x $\frac{3}{4}$ " O.D. Flange Bearings
 - (2) $\frac{3}{8}$ " T-Nuts
 - (2) $\frac{3}{8}$ " Leg Levelers
 - (12) #8 x $3\frac{1}{2}$ " Fh Woodscrews
 - (8) #8 x $2\frac{1}{2}$ " Fh Woodscrews
 - (54) #8 x $1\frac{1}{4}$ " Fh Woodscrews
 - (8) #8 x 3" Fh Woodscrews
 - (2 Pr.) 3" x 2" Butt Hinges
 - (2) $\frac{1}{8}$ " x 2" - 17" Steel Plate
 - (2) $\frac{5}{8}$ " x $17\frac{3}{4}$ " Steel Rod
 - (1) $\frac{7}{16}$ " x $1\frac{7}{8}$ " Spring
 - (1) 3" x 2" Loose Pin Hinge
 - (2) $3\frac{1}{2}$ " Sash Pulls (w/screws)
 - (2 Pr.) 2" x $1\frac{5}{8}$ " Hinges w/screws
 - (2) Magnetic Catches & Strike Plates (w/screws)
 - (12) $\frac{1}{4}$ " Shelf Pins
 - (1) Vise & Handle w/mounting hardware (Opt.)
 - (2) Magnetic Tool Bars w/screws (Opt.)
- Note: Hardware list does not include hardware for mounting workstation, tool rack, or cabinet to wall.

2" x 10" - 12' (THREE BOARDS)



2" x 4" - 96" (TWO BOARDS)

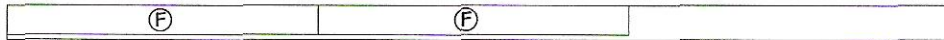

2" x 4" - 96"



2" x 4" - 96" (TWO BOARDS)



2" x 4" - 96"



2" x 4" - 96"



2" x 4" - 96" (TWO BOARDS)



2" x 4" - 96" (TWO BOARDS)



Materials

Workbench

A Top (1)	2 1/2 x 24 - 59 3/4
B Side Panels (2)	9 1/4 x 18 7/8 - 1 1/2 Ply.
C Edging	3/4 x 1 1/2 - 96 Rgh.
D Stretchers (2)	1 1/2 x 3 1/2 - 60
E Corner Braces (4)	1 1/2 x 4 - 10
F Legs (2)	3 x 3 - 31 1/2
G Rails (4)	1 1/2 x 3 1/2 - 17 3/4
H Spacers (2)	3/4 Rgh. x 3 - 5
I Stops (2)	1 x 1 1/2 - 2 Rgh.
J Face Block (1)	3 x 4 1/2 - 10

Tool Rack

K Top Rail (1)	1 1/2 x 1 1/2 - 61
L Bottom Rail (1)	1 1/2 x 3 1/2 - 60
M End Stiles (2)	1 1/2 x 1 1/2 - 20

N Center Stiles (2)	1 1/2 x 1 1/2 - 19
O Pegboard Panel (1)	18 x 28 - 1/4 Pgbd.
P Hardboard Panel (1)	18 x 28 - 1/4 Hdbd.
Q Filler Panel (1)	17 x 27 - 3/4 Ply.
R Filler Strip (1)	1/4 x 1 1/2 - 3
S Benchtop Stop (1)	1 1/2 x 2 7/8 - 18 1/8

Wall Cabinet

T Top/Bottom (2)	9 1/4 x 62 1/2 - 3/4 Ply.
U Sides (2)	9 1/4 x 20 - 3/4 Ply.
V Dividers (2)	9 x 18 1/4 - 3/4 Ply.
W Back (1)	18 3/4 x 62 - 1/4 Hdbd.
X Side Shelves (2)	8 x 20 3/8 - 3/4 Ply.
Y Center Shelf (1)	8 x 18 7/8 - 3/4 Ply.
Z Side Edging (2)	3/4 x 3/4 - 20 3/8
AA Center Edging (1)	3/4 x 3/4 - 18 7/8

BB Cleats (2)	3 1/2 x 20 1/2 - 3/4 Ply.
CC Frame Rails (6)	3/4 x 1 1/2 - 19
DD Frame Stiles (4)	3/4 x 1 1/2 - 20
EE Filler Strip (1)	1 1/2 x 3 1/4 - 62
FF Door Rails (4)	3/4 x 2 1/2 - 14 3/8
GG Door Stiles (4)	3/4 x 2 1/2 - 16 7/8
HH Door Panels (2)	12 3/8 x 14 3/8 - 1/4 Hdbd.

36" x 96" - 1/4" HARDBOARD

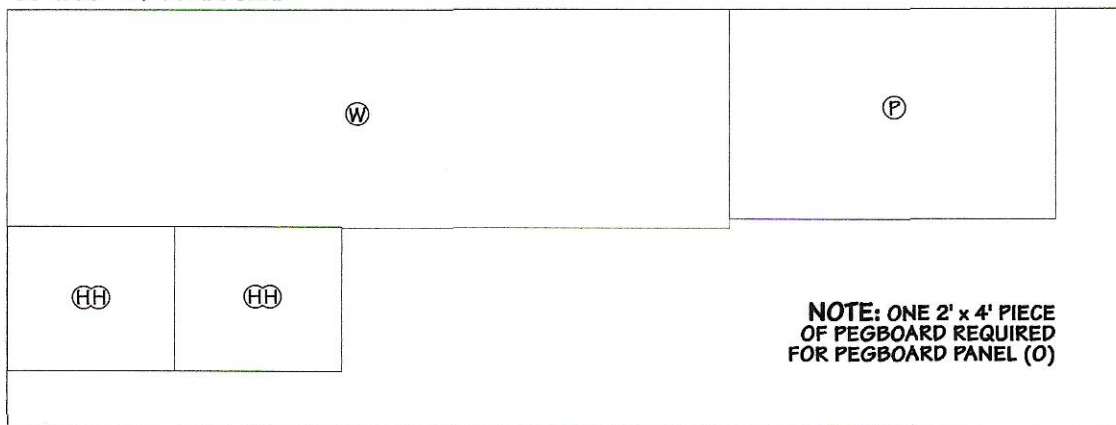

48" x 96" - 3/4" PLYWOOD

