

**FAST,
FOOLPROOF
BOX JOINTS** p. 12

Secret Supply Sources You Can Use

ShopNotes®

Vol. 13

www.ShopNotes.com

Issue 75

PLANK-TOP WORKBENCH

Build it in a
Weekend —
Use it for a Lifetime p. 16

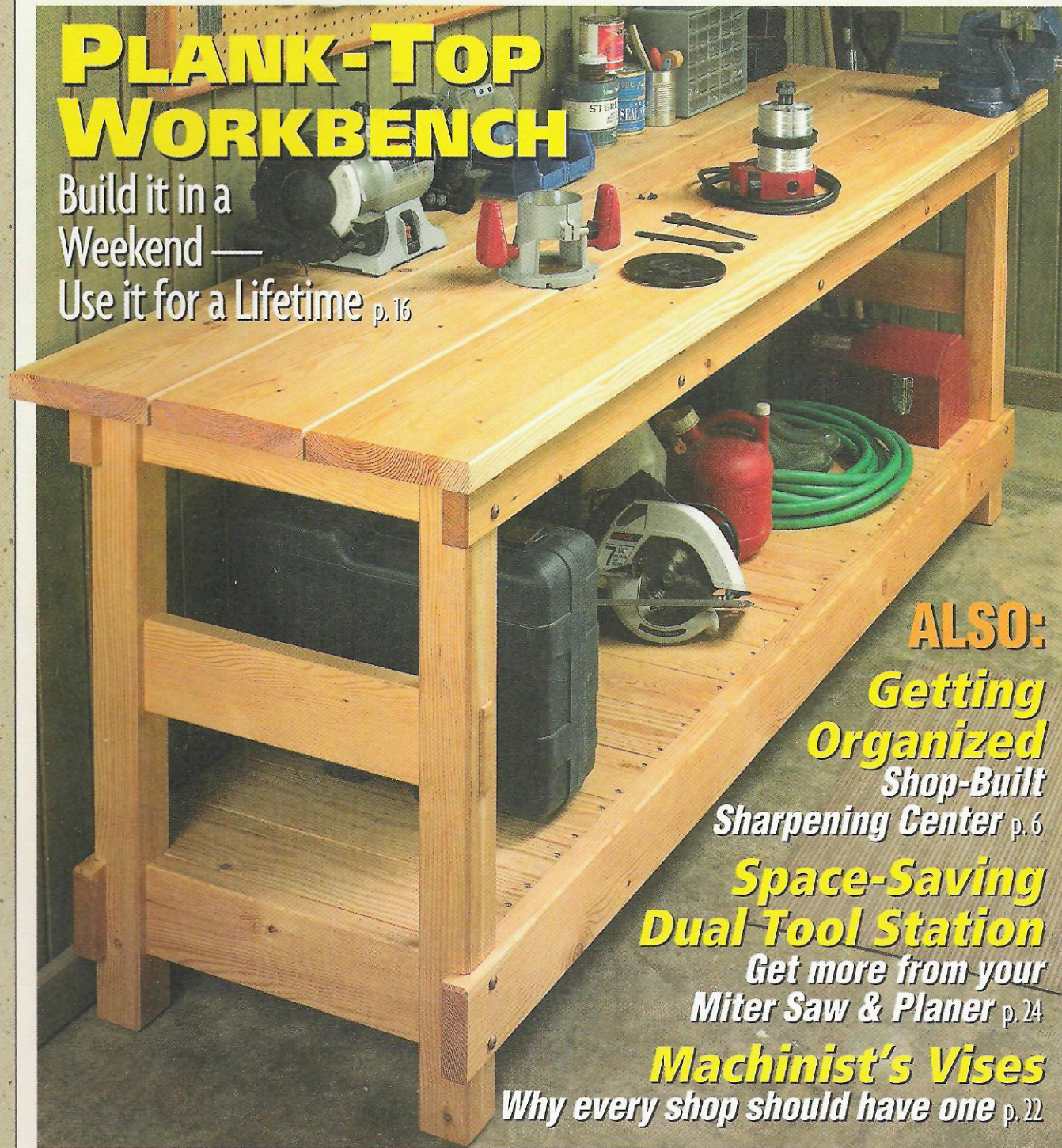

ALSO:

**Getting
Organized
Shop-Built**

Sharpening Center p. 6

**Space-Saving
Dual Tool Station**

**Get more from your
Miter Saw & Planer** p. 24

Machinist's Vises

Why every shop should have one p. 22

PUBLISHER Donald B. Peschke
EDITOR Terry J. Strohman
ASSOCIATE EDITORS Bryan Nelson
 Vincent Ancona
CONTRIBUTING EDITOR Phil Huber
ART DIRECTOR Cary Christensen
SENIOR ILLUSTRATOR Roger Reiland
ILLUSTRATORS David Kallemyn
 Peter J. Larson
SR. GRAPHIC DESIGNER Jamie Downing

CREATIVE RESOURCES

Creative Director: Ted Kralicek • *Sr. Project Designers:* Ken Munkel, Kent Welsh, Ryan Mimick, Chris Fitch • *Shop Craftsmen:* Steve Curtis, Steve Johnson • *Sr. Photographer:* Crayola England • *Photographer:* Tobin Bennett

SPECIAL PUBLICATIONS

Corp. V.P.: Douglas L. Hicks • *Art Dir.:* Douglas A. Flint • *Sr. Graphic Designers:* Chris Glowacki, Mark Hayes, Jr. • *Graphic Designer:* Katie Beckman • *Sr. Editor:* Craig Rueggsegger • *Assoc. Editor:* Joel A. Hess

CIRCULATION

Circ. Oper. Director: Sandy Baum • *Circ. Marketing Dir.:* Wayde J. Klingbeil • *Strategic Business Analysts:* Kris Schlemmer, Paula M. DeMatteis • *Circ. Marketing Analyst:* Patrick Walsh • *Renewal Mgr.:* Paige Rogers • *Circ. Marketing Assoc.:* Christine Forret • *Circ. Fulfillment Mgr.:* Stephanie Forinash • *Sr. Graphic Designers:* Robin Friend, Randy Shebek

CORPORATE SERVICES

V.P. of Finance: Mary R. Scheve • *Controller:* Craig Stille • *Sr. Acct.:* Laura J. Thomas • *Accts. Payable:* Mary J. Schultz • *Accts. Receivable:* Margo Petrus • *Prod. Dir.:* George Chmielarz • *Electronic Pub. Dir.:* Douglas M. Lidster • *Sys. Admin.:* Cris Schwanebeck • *P.C. Maint. Tech.:* Robert D. Cook • *Pre-Press Image Specs.:* Troy Clark, Minnette Johnson • *Assoc. Style Dir.:* Rebecca Cunningham • *New Media Mgr.:* Gordon C. Gaippe • *Multimedia Art Dir.:* Eugene Pedersen • *Web Server Admin.:* Carol Schoeppler • *Web Content Mgr.:* David Briggs • *Multi-media Designer:* Kara Blessing • *Web Prod.:* Terry Walker • *Research Coord.:* Nicholas A. Jaeger • *Prof. Dev. Dir.:* Michal Sigel • *H.R. Asst.:* Kirsten Koele • *Office Mgr.:* Natalie Lonsdale • *Facilities Mgr.:* Kurt Johnson • *Admin. Asst./Recept.:* Jeanne Johnson • *Mail Room Clerk:* Lou Webber • *Admin. Asst.:* Danielle Deknoblough

ShopNotes® (ISSN 1062-9696) is published bimonthly (Jan., March, May, July, Sept., Nov.) by August Home Publishing, 2200 Grand, Des Moines, IA 50312.

ShopNotes® is a registered trademark of August Home Publishing ©Copyright 2004 by August Home Publishing. All rights reserved.

Subscriptions: Single copy: \$4.95. One year subscription (6 issues), \$27.95. Canada/International add \$10 per year, U.S. funds.

Canadian Subscriptions: Canada Post Agreement Number 40649740. Send change of address information and blocks of undeliverable copies to PO Box 881, Station Main, Markham, ON L3P 8M6.

Periodicals Postage Paid at Des Moines, IA and at additional mailing offices.

Postmaster: Send change of address to ShopNotes, P.O. Box 37103, Boone, IA 50037-2103.

Online Customer Service. www.ShopNotes.com

- Access your account
- Check a subscription payment
- Tell us if you've missed an issue
- Change your mailing or email address
- Renew your subscription
- Pay your bill

Email: shopnotes@shopnotes.com

Write to ShopNotes, P.O. Box 842, Des Moines, IA 50304 or call 1-800-333-5075, 8:00 am to 5:00 pm, Central Time, weekdays. Or send an email to:

orders@shopnotes.com

Cutoffs

Build a workbench. If you're a woodworker, the first thing that comes to mind is probably a traditional-style bench. The kind of bench that features a glued-up top, with built-in vises and holes for bench dogs. This type of bench works great, and we've featured several designs in *ShopNotes* over the years. But building a "traditional" bench usually means a serious commitment in time and materials.

So wouldn't it be nice if you could build a sturdy, serviceable workbench without spending a great deal of time or money. Well, that's the idea behind the feature project in this issue.

Plank-top Workbench — For starters, the entire bench is built out of common, construction-grade materials. Nothing fancy, just 2x6's, 2x10's and 1x6's. One thing to note, we decided on Douglas fir for our bench. It costs slightly more than your standard SPF or "white wood," but if you're going to build a bench to last a lifetime, I think the extra cost is worth it.

Of course, just because a bench is built out of heavy-duty material doesn't mean it's sturdy. I've seen benches built out of two-by material you'd be afraid to lean against, much less work on.

To make sure this bench is rock-solid, the leg assemblies are connected with through mortise and tenon joinery. But don't worry, you won't have to spend any time chopping mortises. The whole operation can be done in a few minutes on the table saw.

Then the leg assemblies are simply connected with stretchers. And a plank top finishes it off. An easy-to-build bench that's almost eight feet long.

Besides being quick, this method of assembly makes it easy to create a bench any length you want. In fact, we have an "online extra" that shows you how to build a super-sized version.

So if you're building your first workbench, or if you'd just like to add a second bench to your shop, be sure to check out the plank-top bench article, beginning on page 16.

Terry

Be included, as a part of the
Woodworking Shop Tours

On the Web

Visit other *ShopNotes* subscribers' workshops and see photos of the shop projects they've built. It's all online at Woodworking Shop Tours on the *ShopNotes* web site:

www.ShopNotes.com

We want you to be part of our shop tours! To submit photos of your favorite *ShopNotes* projects or views of your shop, just follow the instructions you'll find on our web site.



Contents

Features

Sharpening Supplies Box _____ 6

The inside of this stacking storage box features multiple compartments on two different layers — plenty of space for all your sharpening supplies.

Making Box Joints _____ 12

Here's a simple table saw technique that allows you to cut the time spent making box joints in half. But don't worry, you won't have to sacrifice accuracy to do it.

Plank-Top Workbench _____ 16

This heavy-duty workbench is equally at home in the shop or the garage. And while it only takes a weekend to build, it's guaranteed to give you a lifetime of use.

Machinist's Vises _____ 22

Discover what a machinist's vise can do for you and what to look for when selecting one for your shop. Plus, learn about some handy vise accessories.

Dual Tool Station _____ 24

This tool station pulls double duty by serving as a planer stand as well as a miter saw station — complete with extension wings and fences.

Departments

Readers' Tips _____ 4

Shop-tested tips to solve common woodworking problems.

Shop Talk _____ 32

Looking for just the right part or hardware item for your next project? Here's a peek at some of our "secret" supply sources.

Tool Chest _____ 34

Take the hassle out of fine-tuning the width of your dadoes with this innovative stack dado blade.

Sources _____ 35

Mail-order sources and supplies to help you complete the projects featured in this issue.

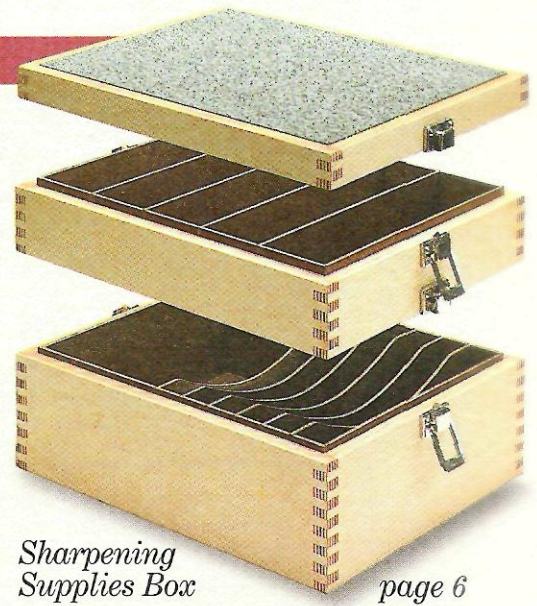

Sharpening Supplies Box

page 6

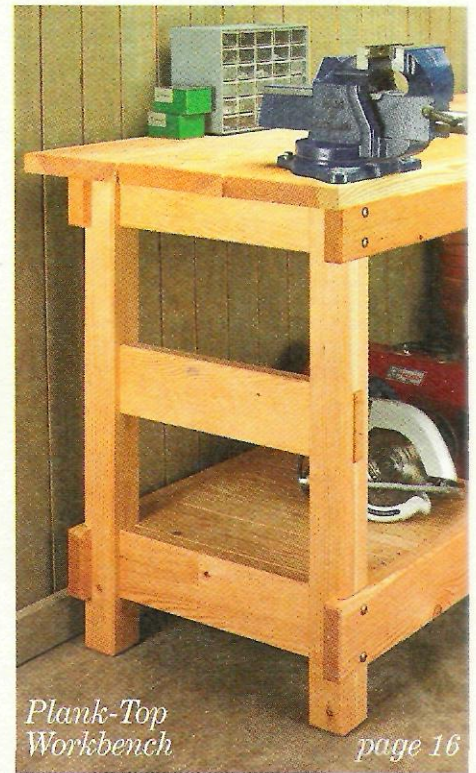

Plank-Top Workbench

page 16

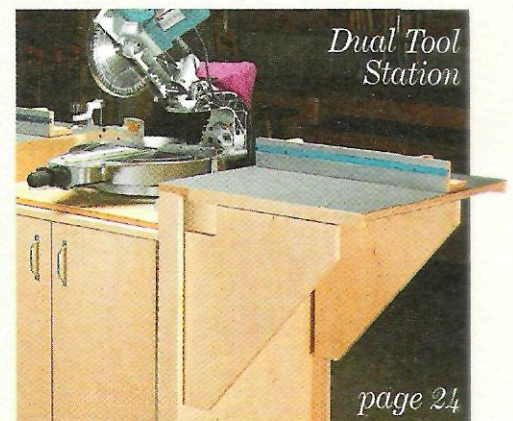

Dual Tool Station

page 24

Readers' Tips

Shop-Made Studded Knobs

■ I started making knobs for shop cabinets and jigs as a way to save money. But I've found that they look and feel better than the hard, plastic knobs found in hardware stores.

The knobs are made from round hardwood scraps, as you can see in the photo at right. To make one, start by drilling a counterbored hole in the center to hold a carriage bolt, as shown in the drawing in the margin. Then you can insert the carriage bolt and epoxy it in place.

Once the epoxy hardens, the knob can be shaped. To do this, I "turned" the knob on the drill press using a few simple tools.

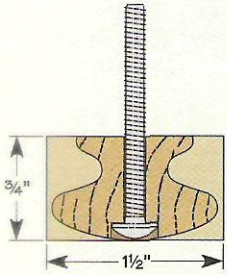

▲ Make knobs for cabinets and jigs from scrap by inserting carriage bolts, then "turning" the knobs in your drill press using rasps and files.

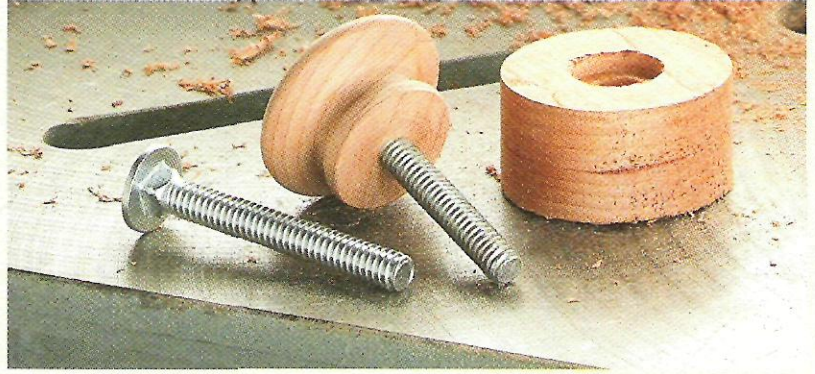

First, chuck the end of the carriage bolt in the drill press and shape the top portion of the knob with a micro plane, as shown in the left photo below. (You could also use a

file or rasp to do this.) Then to form the stem of the knob, I used a round wood file, as in the right photo.

*George Sparkman
Gainesville, Texas*

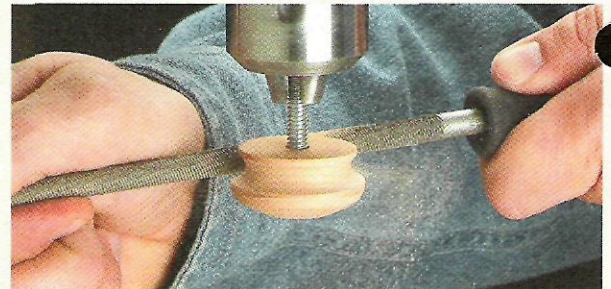
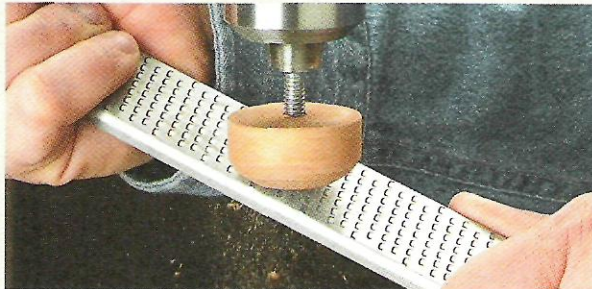

PVC Clamp Holders

■ Like many woodworkers, I don't have a lot of room in my shop. So I try to make the most of the space that I have. Since most of my wall space is already taken up with cabinets and counters, I needed to find a place to store my long pipe clamps. So I turned to the ceiling, as you can see in the photo at right.

The clamp rack makes it easy to organize the clamps and keep them within easy reach. Best of all, the storage rack doesn't take a lot of time or materials to build. It consists



of two identical parts. Each section is a piece of "two-by" stock that gets screwed to the ceiling joists. Next a series of PVC holders is attached. The 2"-dia. PVC holders have a

cutout that makes it easier to get the clamps in and out of the rack, as in the photo in the left margin.

*Trent Cercle
Green Cove Springs, Florida*

Quick Tips



▲ Irvin Schmidt of Lakewood, WA uses a pencil sharpener to chamfer the edges of dowels so they'll slip into their matching holes easier.



▲ To jot down notes and to-do lists, Steve Jones of Minneapolis, MN mounted a dry-erase board and marker to the inside of his shop cabinet door.

Modular Router Bit Organizer

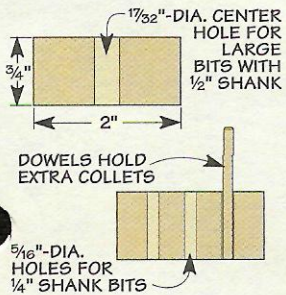

■ As my router bit collection grew, I needed an easy way to organize the bits and protect the carbide cutting edges. So I came up with a modular organizing system, see photo.

The system consists of 2"-square MDF "tiles" that hold the bits. The tiles

keep the cutting edges from hitting each other. For large-diameter bits, I drilled a single, centered shank hole. For smaller bits, you can drill several holes in one tile. I even mounted a pair of dowels in one tile to hold extra collets. The individual tiles make it easy to rearrange and expand the system as you add new bits.

*Bob Wey
Westford, Massachusetts*

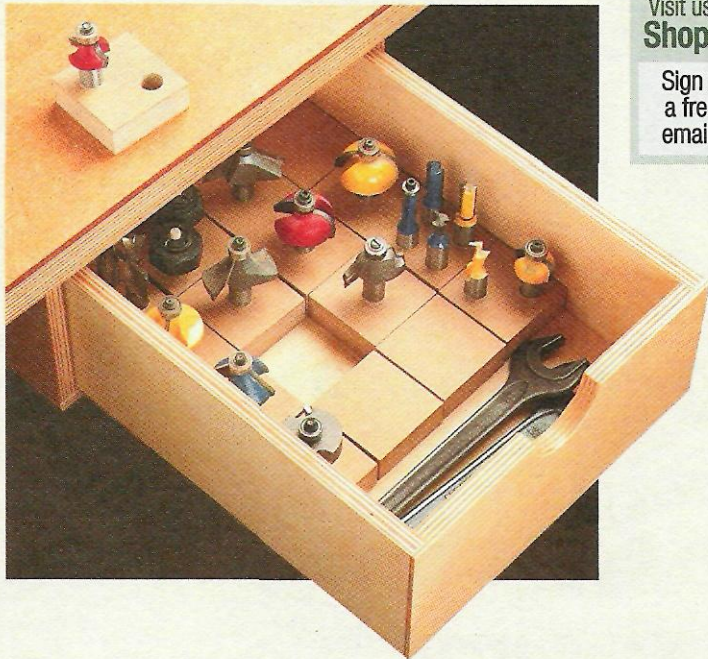

Free Tips ON THE WEB

Get more wood-working tips **free**.

Visit us on the Web at ShopNotes.com

Sign up to receive a free shop tip by email every week.

Concave Palm Sander

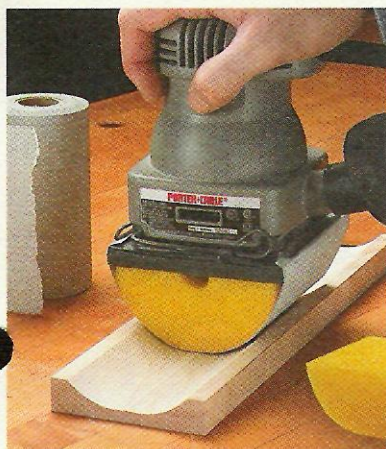

■ To make sanding concave surfaces quicker and easier, I cut a section from a foam pool flotation tube and attached it to the bottom of my palm sander.

*Richard Beal
Fort Polk,
Louisiana*

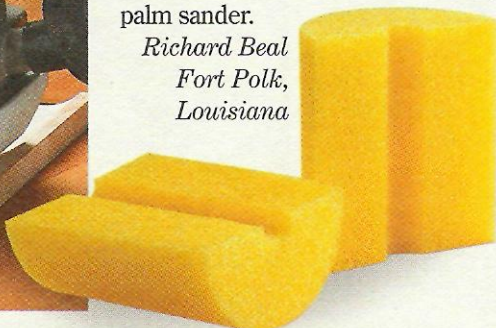

Send in Your Shop Tips

If you have a unique shop tip, we'd like to consider featuring it in one or more of our print or electronic publications.

We'll pay up to \$200 for a tip we publish. Just write down the tip and mail it to *ShopNotes*, Attn.: Readers' Tips, 2200 Grand Ave., Des Moines, IA 50312. Or FAX it to 515-282-6741, or send us an email at shopnotes@shopnotes.com. Please include your name, address, and daytime phone number in case we have any questions.

Sharpening Supplies Box

Corral all your sharpening supplies in one spot and you'll never have to deal with a dull tool again.



The biggest hassle I had with sharpening was rounding up all the supplies. It seemed like they had a habit of wandering to the far corners of my shop.

Well, that's not a problem anymore. Since I built the sharpening box shown here, my supplies are always close at hand. Everything stores neatly in customized compartments and the lid doubles as a sharpening area, keeping my benchtop clean and mess-free.

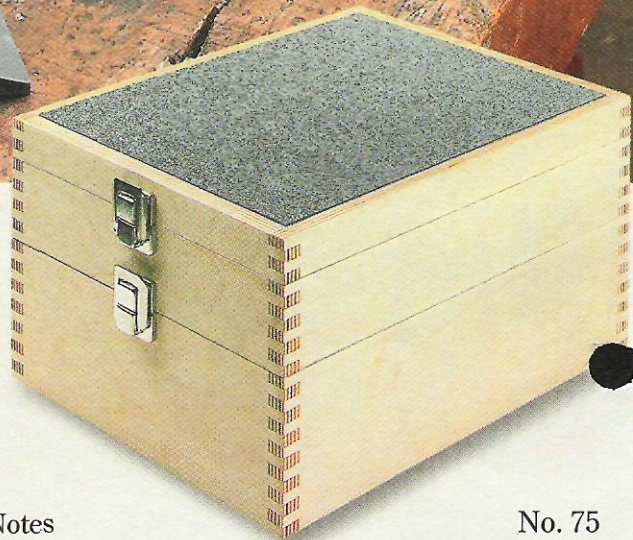

EXPLODED VIEW
OVERALL DIMENSIONS:
 (12³/₄"W x 9³/₄"D x 6¹/₂"H)



INTERLOCKING DIVIDERS
 CREATE BINS FOR STORING
 A WIDE VARIETY OF
 SHARPENING ACCESSORIES

ANTI-SKID TAPE PREVENTS
 LID AND STONES FROM SLIDING
 AROUND AS YOU SHARPEN

LINERS FORM
 RAISED LIP
 TO KEEP
 COMPARTMENTS
 ALIGNED WITH
 EACH OTHER

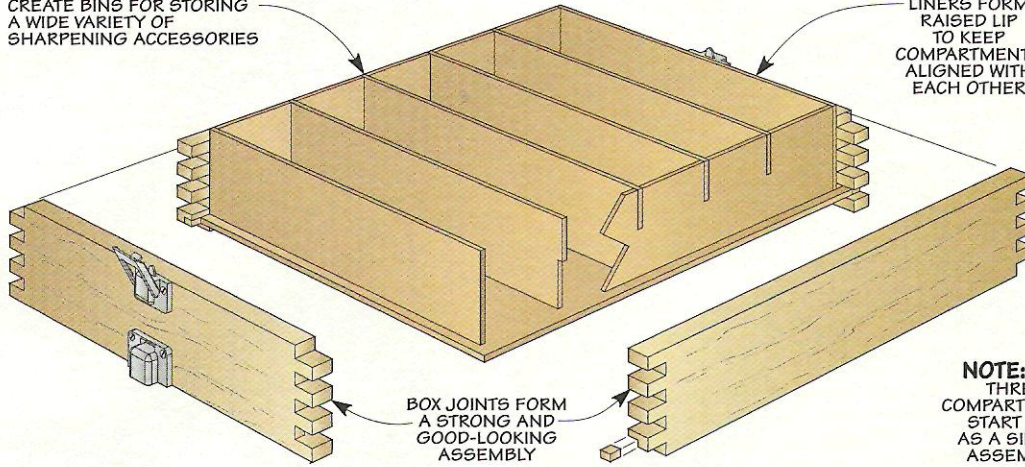

BOX JOINTS FORM
 A STRONG AND
 GOOD-LOOKING
 ASSEMBLY

NOTE: THE
 THREE
 COMPARTMENTS
 START OUT
 AS A SINGLE
 ASSEMBLY

NARROW SLOTS FORMED
 BY CURVED DIVIDERS PROVIDE
 EASY ACCESS TO SHARPENING
 STONES OR DIAMOND
 PASTE BLOCKS

CATCHES LOCK
 COMPARTMENTS
 TOGETHER

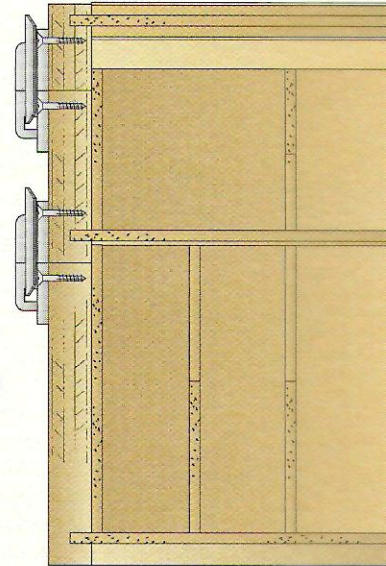

SIDE VIEW
 (CROSS SECTION)

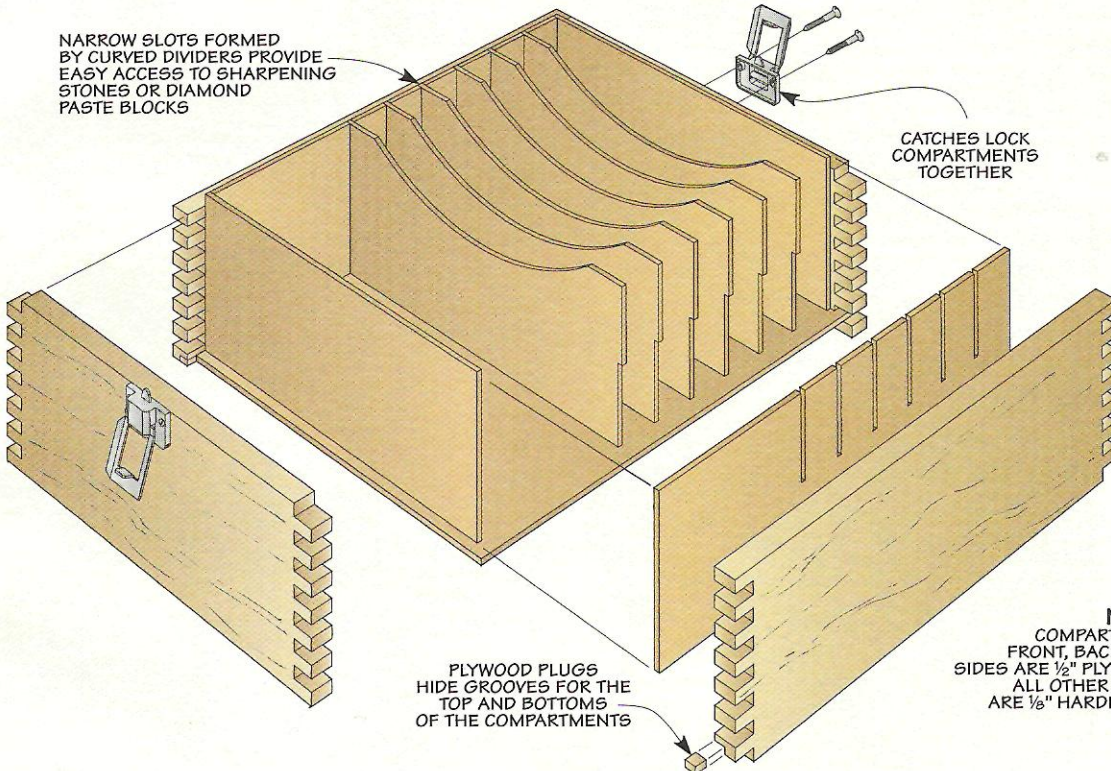

PLYWOOD PLUGS
 HIDE GROOVES FOR THE
 TOP AND BOTTOMS
 OF THE COMPARTMENTS

NOTE:
 COMPARTMENT
 FRONT, BACK, AND
 SIDES ARE 1/2" PLYWOOD.
 ALL OTHER PARTS
 ARE 1/8" HARDBOARD

Materials & Hardware

A Front/Back (2)	8 Rgh. x 12 - 1/2 Ply.	G Tall End Liners (2)	3 ³ / ₈ x 8 ³ / ₄ - 1/8 Hdbd.
B Sides (2)	8 Rgh. x 9 ³ / ₄ - 1/2 Ply.	H Tall Front/Back Liners (2)	3 ³ / ₈ x 10 ³ / ₄ - 1/8 Hdbd.
C Top/Bottoms (3)	9 1/4 x 11 1/2 - 1/8 Hdbd.	I Tall Dividers (6)	3 ³ / ₈ x 8 ³ / ₄ - 1/8 Hdbd.
D Short End Liners (2)	1 1/8 x 8 ³ / ₄ - 1/8 Hdbd.	J Lid Inserts (2)	8 ³ / ₄ x 11 - 1/8 Hdbd.
E Short Front/Back Liners (2)	1 1/8 x 10 ³ / ₄ - 1/8 Hdbd.	• (4) Catches w/screws	
F Short Dividers (4)	1 1/8 x 8 ³ / ₄ - 1/8 Hdbd.	• (5 Ft.) Anti-Skid Tape (4" wide)	

Build a Box

One of the unique features of this sharpening box is the way the three compartments stack together perfectly flush. So the challenge is building each compartment so it's flat, square, and identical in size.

I've found that the best way to do this is to build the box as a single assembly. This way, you can cut each compartment free, guaranteeing they're all identical.

Blanks - I made my box out of 1/2" Baltic birch plywood, so all I had to do was cut the pieces to size. But there are a couple things to keep in mind as you do this.

First, you'll want to make sure the blanks are extra wide. (I made my blanks about 8" wide.) The extra width serves an important purpose - it allows for any variation in the actual size of the box joints as you cut them. This ensures a consistent set of pins and slots on each corner of the box when you cut the compartments to final size. (For an alternate joinery method, refer to the box on the opposite page.)

The other thing to keep in mind is to make a couple extra blanks to use

1 OVERVIEW

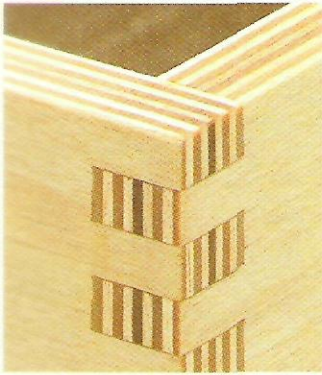
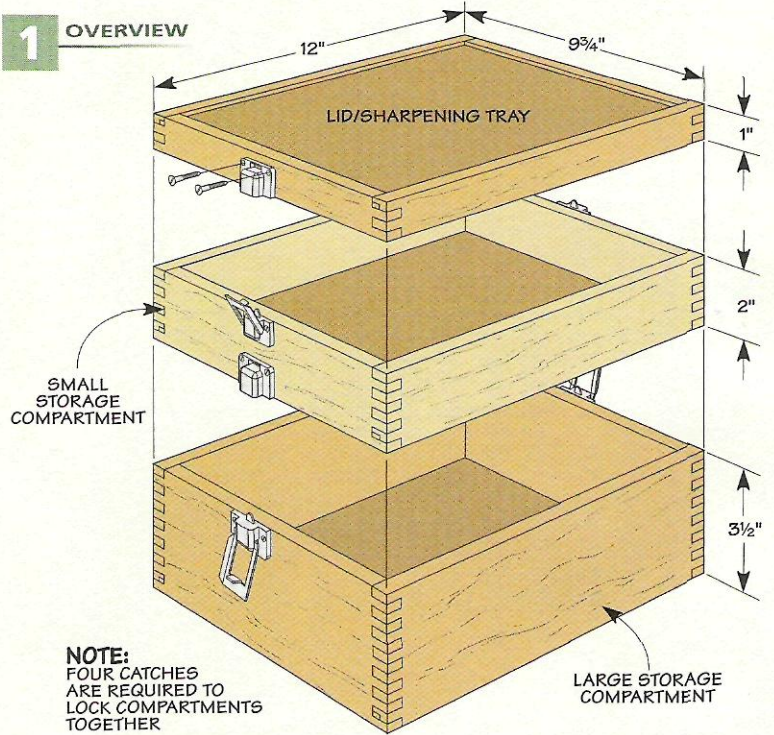

▲ **Box Joint.** The classic look and exceptional strength of a box joint makes it the perfect choice for assembling small boxes.

as test pieces when you set up the box joint jig. Just make sure they're the same width as your workpieces.

Once you have the blanks cut to size, you can cut the box joints. The fingers on this box are 1/4" wide by 1/2" long. (For more on cutting box joints and the jig I used, see page 12.)

With the box joints cut, the next step is to do a little layout work. First, working from the bottom of each blank, mark out the waste areas as well as the grooves for the top and bottoms (Figures 2, 2a, and 2b).

Assembly - After cutting the grooves for the top and two bottom

2 FIGURE

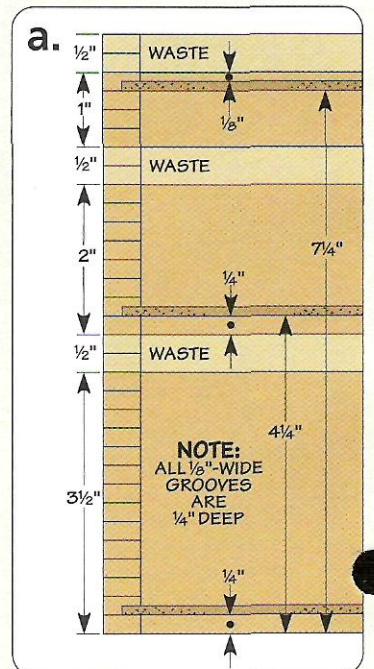
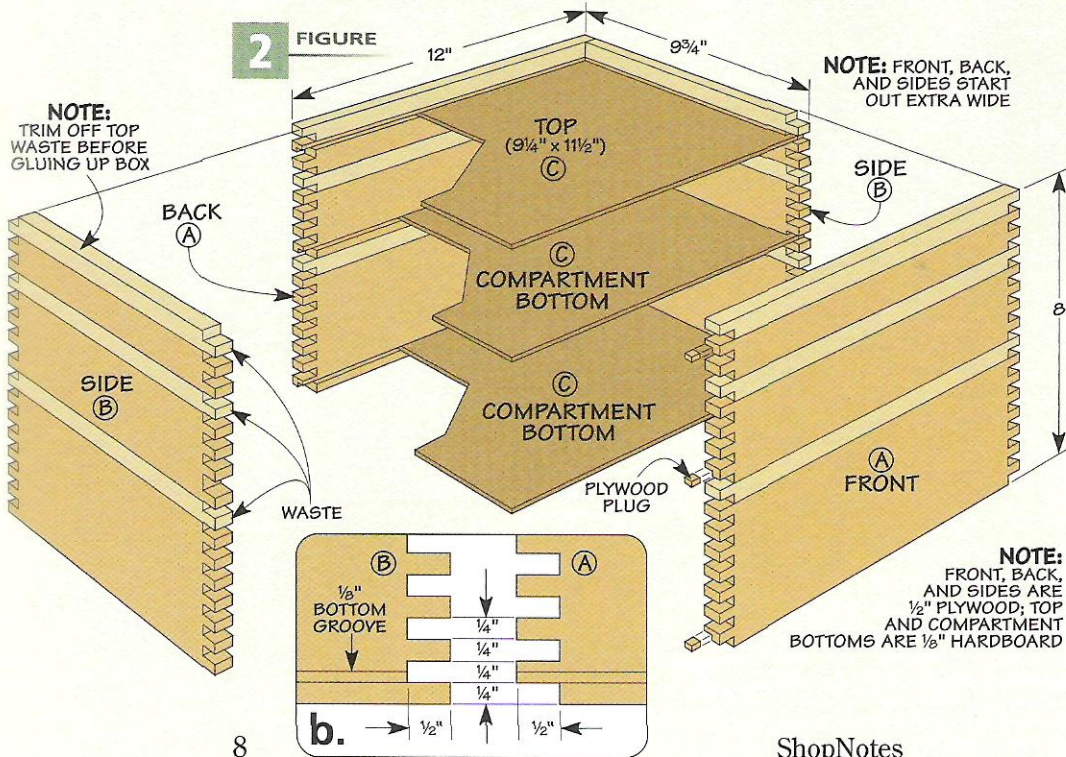

pieces, you can glue up the box. Next, plug the holes for the grooves and then sand the box joints flush.

Cutting the Box Apart – At this point, you're ready to cut the box into three parts. To do this safely, start by cutting through the long sides (Figures 3 and 3a). Next, lower the blade to about $1/32$ " less than the thickness of the plywood and make a scoring cut through the short sides, lining the blade up with the previous cuts (Figure 3b).

Once all the cuts are complete, use a utility knife to cut through the remaining material on the sides of the box (Figure 3c).

This process can leave the edges a little rough. So to get a perfect fit, I attached some self-adhesive sandpaper to my saw table and sanded the edges of each compartment smooth.

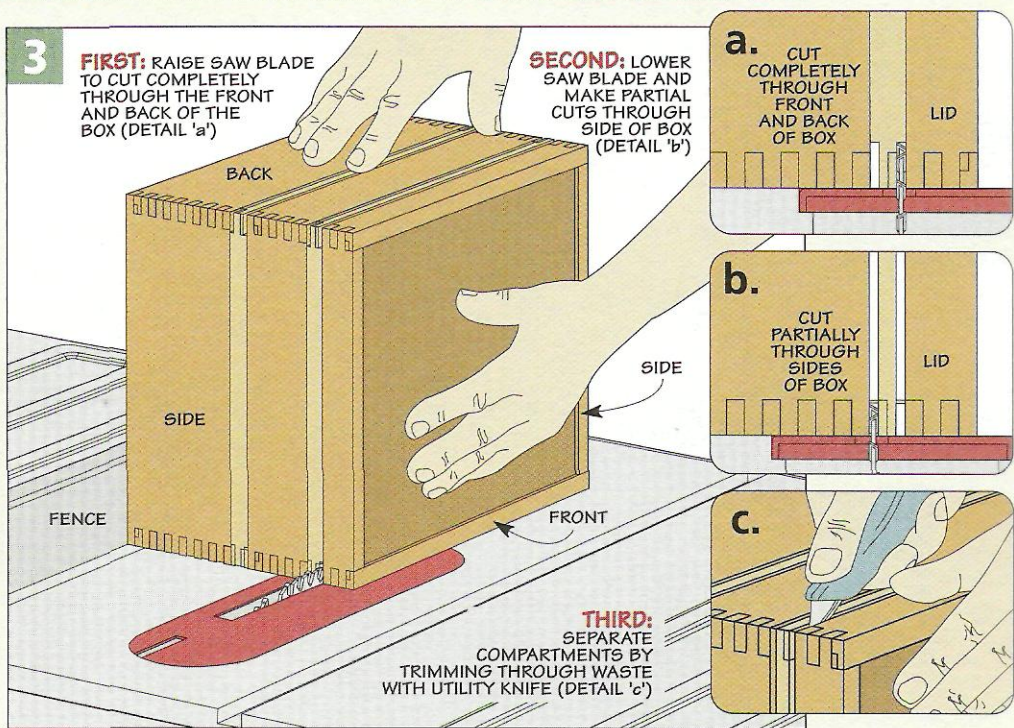

Optional Splined-Miter Joinery

If you'd rather not make a box joint jig and cut box joints, you can build the sharpening box with mitered corners reinforced with splines, like you see in the photo at right.

There's not much to change here. The box pieces are all the same length, but they aren't quite as wide since you only have to allow for two

saw kerfs when cutting the compartments apart. You can see this in the drawing below.

To help strengthen the joint, I added a hardboard spline to each miter (detail 'a'). Once you've glued up the case, simply cut the compartments free using the dimensions detailed in the drawing below.

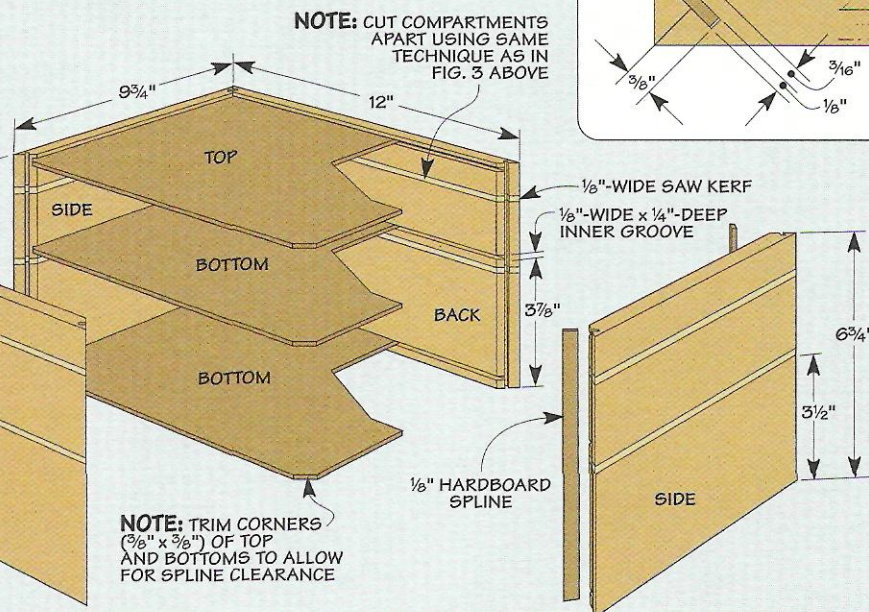
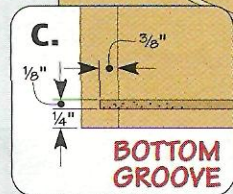
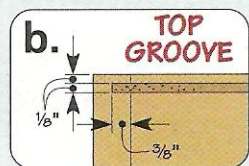
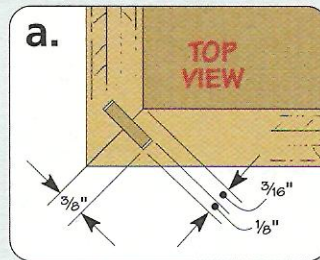

Line It & Divide It

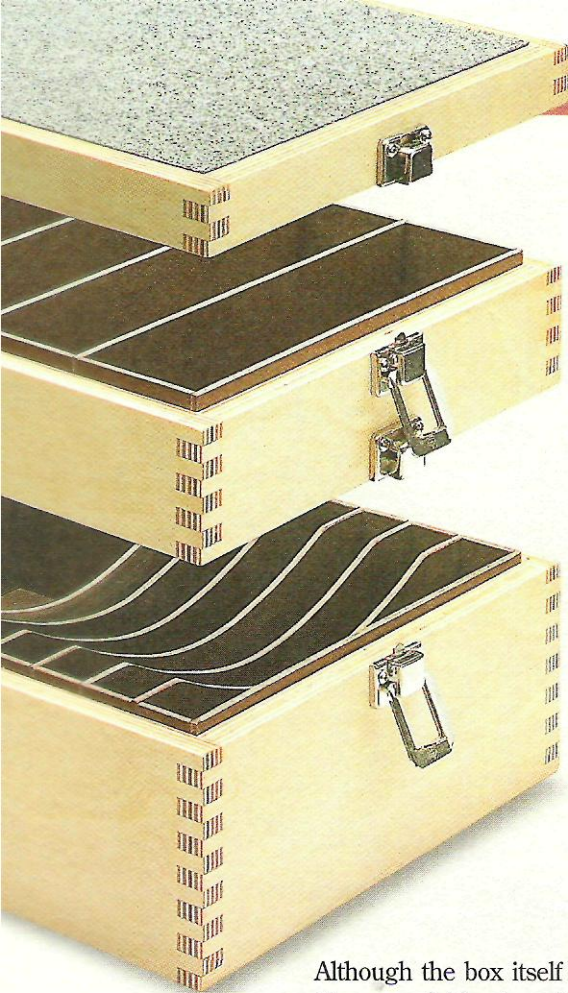

4 FIGURE

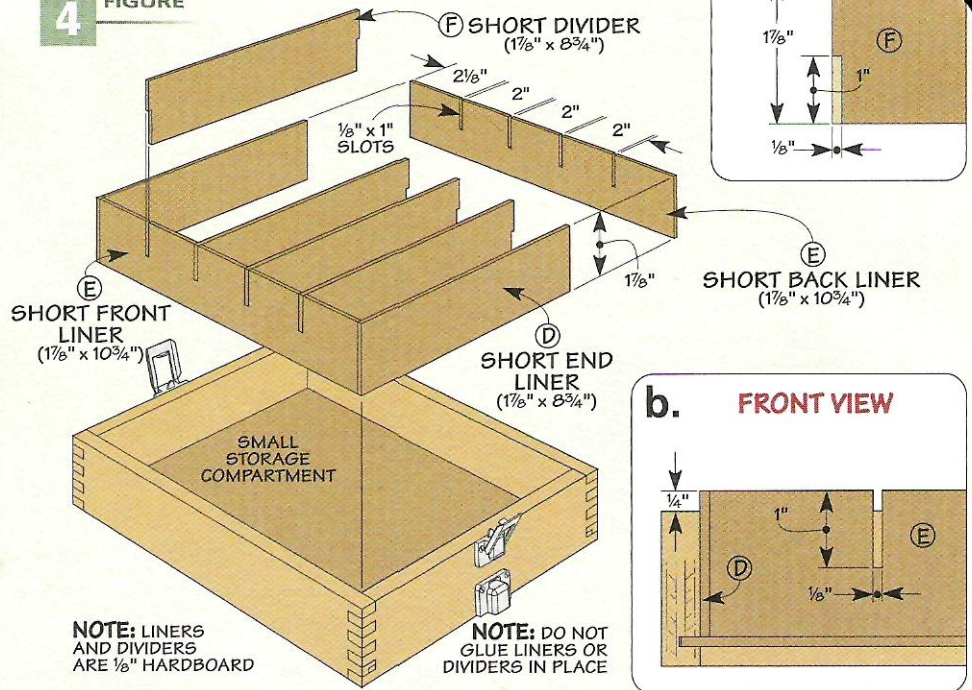

NOTE: LINERS AND DIVIDERS ARE 1/8" HARDBOARD

NOTE: DO NOT GLUE LINERS OR DIVIDERS IN PLACE

Although the box itself is complete, it's a good idea to add some customized dividers, like the ones you see in the photo. They'll keep everything inside both compartments organized and easily accessible. Plus, they help prevent any damage as you move the box around the shop.

But what I like even more is that the interlocking dividers go in *after* the box is complete. That means, you can configure the dividers any way you'd like. Another benefit — if your needs should change in the future, it's a simple matter to reconfigure everything.

Flexible Layout – As you can see in Figures 4 and 5, I didn't use the same spacing in the two compartments. In the center storage area, I organized the interior of the box with evenly spaced, interlocking 1/8" hardboard dividers.

For the lower compartment, I created one large area for odds and ends and several narrower slots that I sized to fit the MDF blocks I use with my diamond paste. But the spacing of the slots can easily be changed to hold any type of sharpening stone. And the curved cutouts make it easy to grab whatever you store in the slot.

Add the Liners – The liners you see wrapping around the inside of each compartment serve two purposes. First, because they stand a little proud of the box, they act as a lip to keep the compartment above it lined up perfectly flush. And second, wherever you make a cut in the long lining, you create a slot for a divider.

After cutting the end liners for both compartments to size and fitting them in the box (don't glue them in place), I cut the long liners to fit between the ends. Next, stack the long liners together and make

5 FIGURE

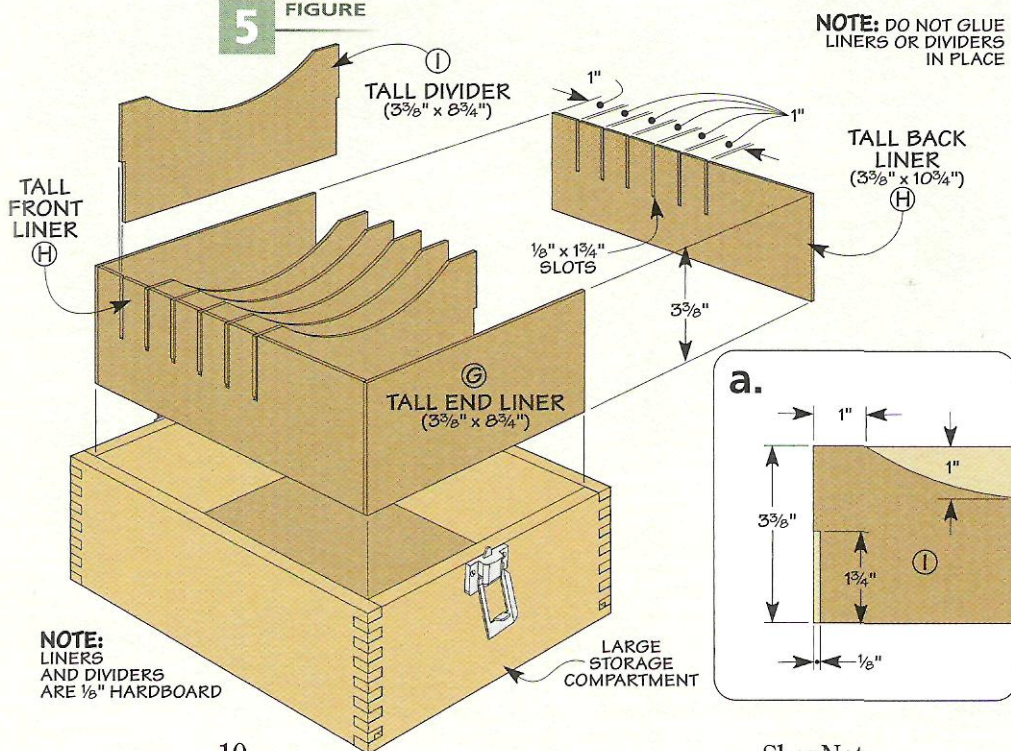

NOTE: LINERS AND DIVIDERS ARE 1/8" HARDBOARD

NOTE: DO NOT GLUE LINERS OR DIVIDERS IN PLACE

kerf-wide slots for the dividers, like you see in Figure 6. (The dimensions you need for the tall liners are illustrated in Figure 5.)

For the dividers, all you need to do is cut them to final size and then notch the ends like you see in Figures 7 and 7a. (Here again, the dimensions for the tall dividers are in Figure 5a.)

To make it easier to get items out of the narrow slots in the lower compartment, I used my band saw to cut shallow curves (Figures 5 and 5a). Then I sanded the edges smooth.

Final Details – The last thing I did to complete the sharpening box was to add some non-skid tape to the inside *and* outside of the lid.

Why both sides? Adding it to the inside allows you to use the lid as a work area. When you're sharpening, the stone won't be sliding around and any mess stays in the lid, not on your benchtop. The tape on the outside keeps the lid in place on your bench as you sharpen.

To ensure the tape makes contact with the benchtop, there's an insert that fits inside the lid (Figure 8). A second insert makes it easy to fit the tape to the inside of the lid.

Once you have the inserts sized, cut some oversized pieces of self-

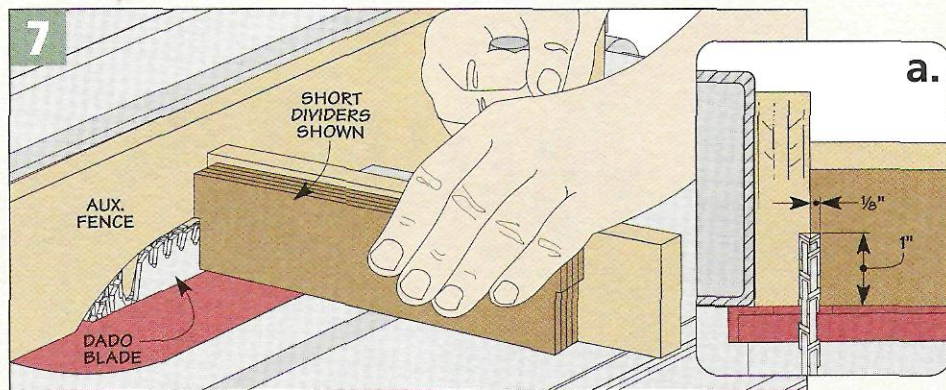
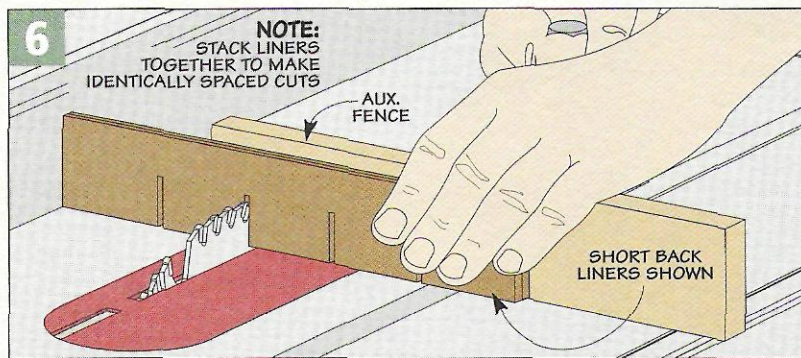

adhesive, anti-skid tape and stick them to the insert. (I picked up my anti-skid tape at a local home center where they sell it by the foot.)

Since my tape was only 4" wide, I had to butt a few strips together to cover each insert. After trimming the tape flush with a utility knife (see

photo at lower right), you can glue each insert in place.

Now all you have to do is gather up all your sharpening supplies and get organized. And you won't be able to use the excuse that you can't find all your stuff to keep you from putting a sharp edge on all your tools. 

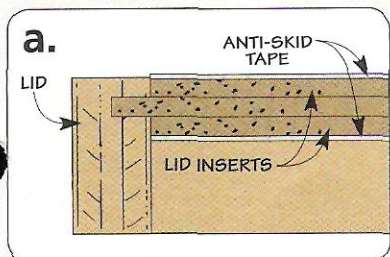
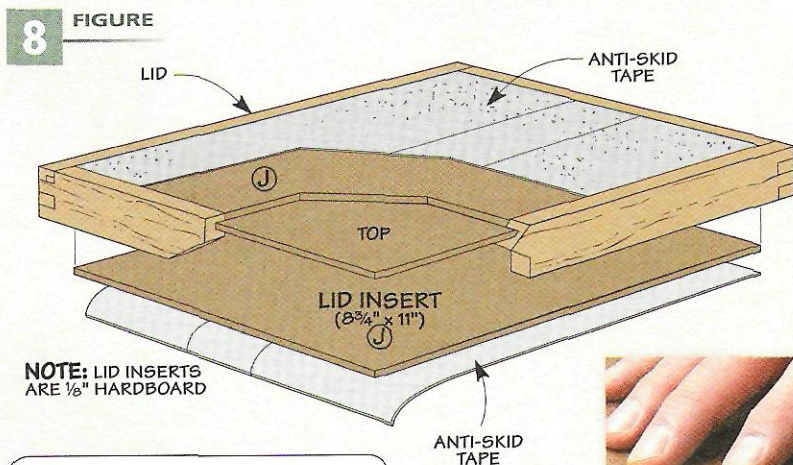

▲ **Attaching Anti-Skid Tape.** After cutting oversized strips of tape, use a roller to secure the tape to each insert. Once that's complete, a utility knife takes care of trimming the excess tape flush with the edges of the insert.

Making Box Joints

Speed up the process of making box joints? With this simple technique, you'll cut the time in half.

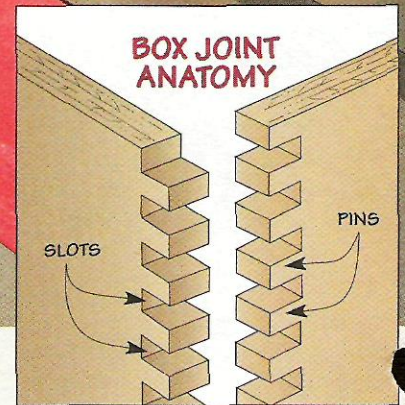

One of the things I really like about box joints is how great they look on a small project, like the sharpening supplies box on page 6. With their rows of evenly spaced pins, box joints have a traditional, almost old-fashioned appeal.

Box joints aren't just good looking. They're also very strong. And box joints are simple to cut—all you need is a table saw.

With all that box joints have going for them, they sound like the perfect joint. But there is one thing I don't like about them—and that's the time it takes to cut them. Even on a small project, it can be a tedious process.

Stacked Cutting—To save some time, I tried something a little different when I cut the box joints for the sharpening supplies box. I *stacked* the mating corners together

as I cut the joint. This process worked great. I was able to get a good, tight fit in about half the time.

The reason this stacking process works is that unlike most other woodworking joints, both halves of a box joint are identical. As you can see in the drawing above, the only difference is that the pins on one piece are offset from the pins on the other so they mate up with the slots.

Even though both parts of the joint are cut at the same time, the trick to getting a good fit with box joints is precision and consistency.

The best way to achieve this is to use a jig. Once the jig is adjusted properly, cutting the joints is almost automatic. (If you don't already have a box joint jig, check out the easy-to-make jig shown at left.)

Of course, adjusting the jig is where the challenge lies. Most box joint jigs use an index key to determine the size *and* spacing of the slots and pins. But in order to get a perfect fit, you have to spend a little

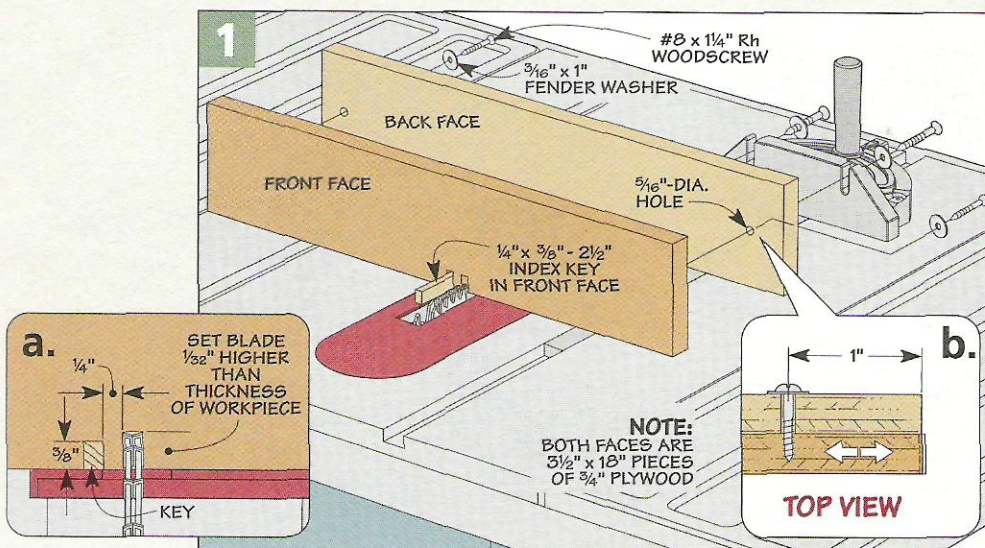

bit of time adjusting the position of the index key in relationship to the blade of your saw. And the best way to do this is to cut some box joints on a couple of test pieces before moving on to your actual workpieces.

Setting Up the Jig – Before you can use the jig, you’ll need to cut a slot for the key that matches the width of the pin, as in Figure 1. Then before you use the jig for the first time, you need to make an initial cut through the front face of the jig with the key spaced approximately the width of the key away from the dado blade as in Figure 1a.

To set the height of the blade, I use a piece of the same stock that I cut my workpieces from and set the blade slightly higher (about 1/32”) than the thickness of my workpieces. This way, the pins will stand a little proud, and you can sand them down flush later.

Test Pieces – Rather than diving right in and cutting the box joints on my workpieces, I like to start with a couple of test pieces. But it’s important that these test pieces be the same thickness *and* width as your actual workpieces.

Why? Even though stacking the workpieces helps with getting a good, consistent fit, I find it best to check the entire setup by cutting a full-width test joint.

Make Test Cuts – The first step is to cut the slot at the bottom of the first workpiece, like you see in Step 1. Then before cutting any more, flip

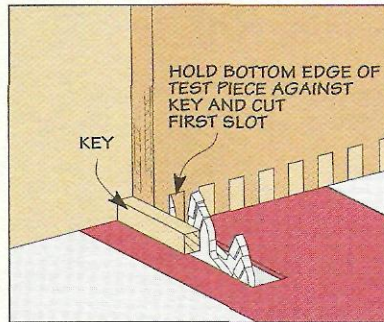

1 After adjusting the spacing to match the approximate width of the key, set the first test piece against the index key and cut a slot.

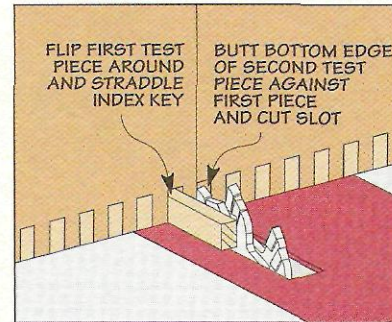

2 Next, flip the first test piece around and set it over the key. Butt the mating test piece against the first and cut another slot.

the test piece around and fit it over the key. Next, butt the mating test piece against it, like you see in Step 2, and cut the open slot at the end.

Now you’re ready to cut all the box joints. In Step 3, you can see how I stacked both test pieces together before cutting all the remaining box joints. This way, any slight variation in pressure or position is accounted for on both pieces at the same time, resulting in a more accurate fit on wide workpieces.

Once you’re done, try fitting the pieces together and compare the results with the drawings below. If the pieces fit together perfectly on the first attempt, great. You’re ready to move on to your actual workpieces.

But chances are that you will have to make an adjustment to your jig by moving the fence (or the index key). On our jig, this is just a matter of loosening the screws at the back of the fence, nudging the fence over a

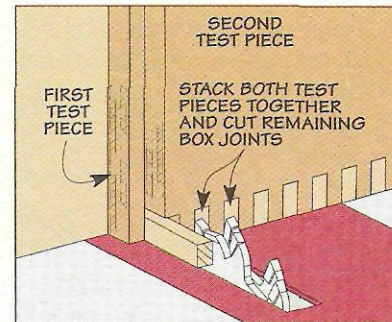

3 Now you can cut the remaining slots by moving both pieces together as you cut all the remaining slots across both pieces.

bit (Figure 1b) and then tightening the screws back down.

The difference between a joint that fits perfectly and one that is too tight or too loose is only a few thousandths of an inch, so move the fence in very small increments. After each adjustment, make another series of test cuts. You may need to repeat this process a few times to “zero in” on the perfect fit.

Checking the Fit

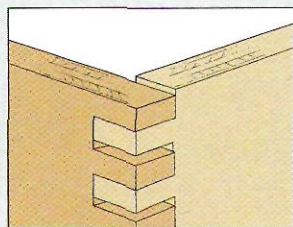

▲ **Loose.** A gap between the pins indicates the index key needs to move away from the saw blade.

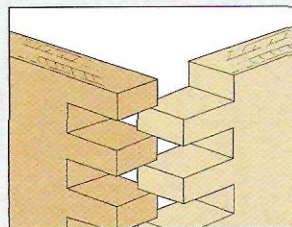

▲ **Tight.** If you can’t fit the pins together at all, you’ll need to slide the index key toward the saw blade.

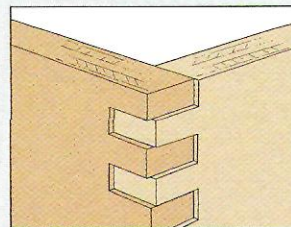

▲ **Short Pins.** Raise the dado blade if the pins don’t extend slightly past each other when mated together.

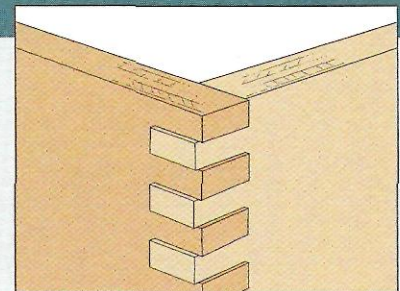

▲ **Perfect and Proud.** With a perfect-fitting box joint, the pins will fit smoothly together. Then just sand them perfectly flush with the surface.

Cutting the Box Joints

2 OVERVIEW

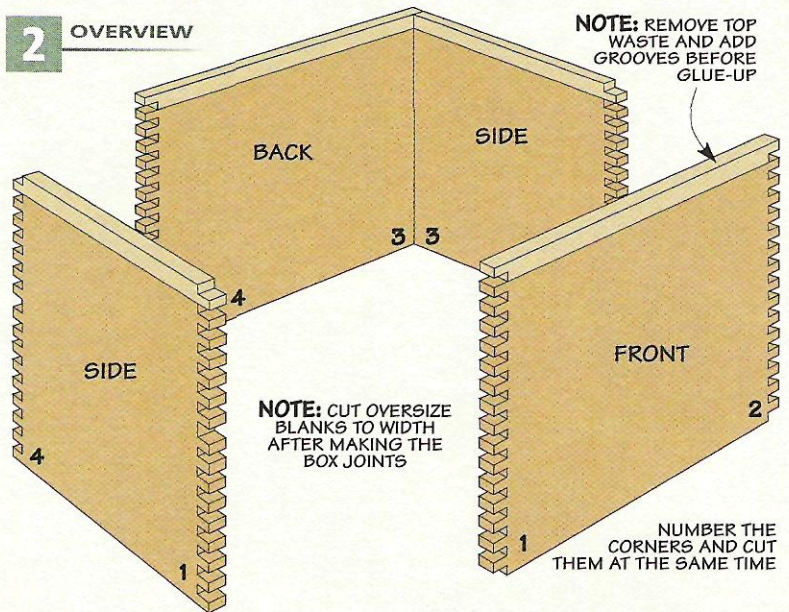

Now that you have the jig adjusted for a perfect fit, you've completed the most time-consuming and challenging part of the box joint process. But there are a couple things to keep in mind when it comes to cutting the box joints on your actual workpieces.

Visual Appeal – When building with box joints, it's more important to me for the project to be *visually accurate*. What do I mean by that?

For instance, on the sharpening box on page 6, the overall height of the box is supposed to be 6½" once the lid and two compartments are cut apart. But whether it ends up exactly this height or not, the important thing

is that there's a full pin (or slot) at the top and bottom of each part.

Extra-Wide Pieces – To do this, I typically start with workpieces that are extra wide and then trim them

down after the box joints are cut, see Step 4. This way, no matter what the actual size of the pin or slot ends up being, I always end up with a full pin (or slot) at the top.

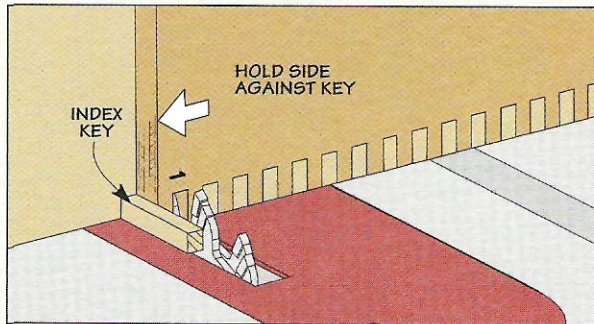

1 After labeling all the parts of the box, begin by setting the bottom of one of the side pieces against the key. Hold it tightly in place against the front face of the jig and then cut the first slot.

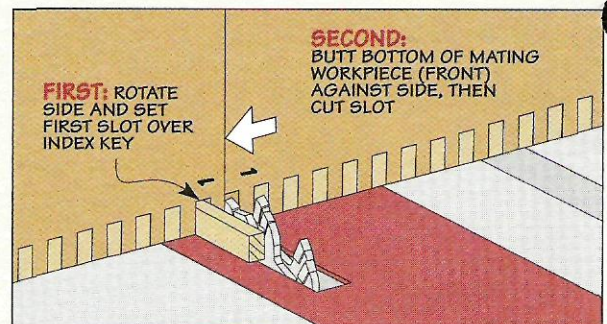

2 Now, flip the side piece around and fit the slot you just cut over the index key. Next, butt the bottom of the mating piece (the front or back) against the side piece and cut the first slot.

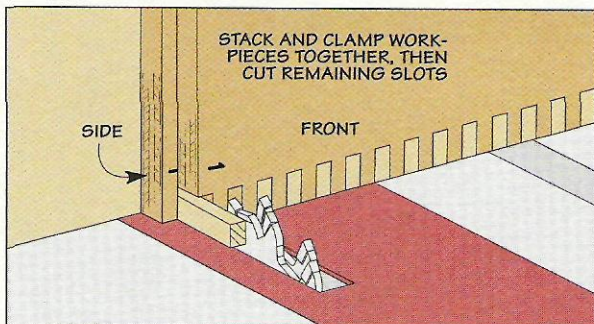

3 At this point, stack the two pieces together so the slots fit over the index key, then clamp them together. Now cut the next slot. Repeat this process until all the slots on this end are cut.

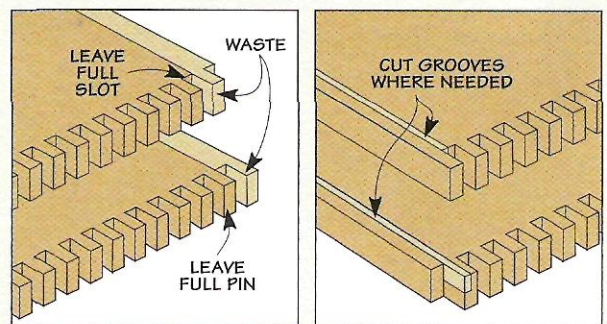

4 After repeating the process for all the corners, you can trim the waste at the top of each piece to leave a full pin and slot. Then lay out and cut the grooves for the top and bottoms of the compartments.

Sure, there are times when a workpiece has to be a specific size, like when building a drawer that has to fit an opening. But even in these cases it's still best to start with an oversize piece. Once you're done cutting the box joints, simply trim the pieces so the pin (or slot) is the same size at the top and bottom.

Label Pieces – To keep myself organized, another thing I like to do is label all the parts and number the joints at the bottom of each piece (Figure 2) so I can be sure to stack the proper parts together with the correct edge against the index key on the jig, as in Steps 2 and 3.

Cutting the Joints – When cutting the box joints, the workpieces can “ride up” the dado blade slightly, resulting in slots of uneven length. So I make sure to keep downward pressure on the workpieces.

Unfortunately, even if your box joints fit perfectly, you may run into another problem — chipout.

Chipout – The jig helps take care of this problem, but there are a few other things you can do to minimize it. First, make sure your blade is sharp. And don't push the pieces through the blade too quickly. If you're getting a lot of chipout, try

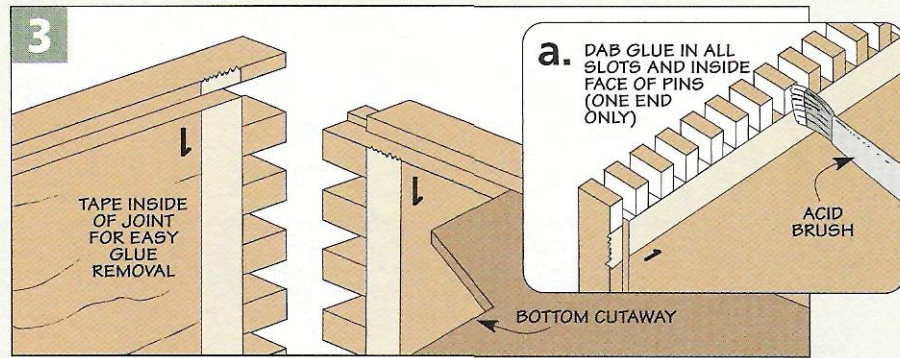

slipping a scrap piece of hardboard behind the workpiece so that each cut is backed up completely.

Smooth Assembly – After cutting the slots on all the parts, you're ready to assemble the box. This can get a little frantic, so I take a few steps to minimize any problems.

First, to make cleaning up any glue squeeze-out easier, I tape the *inside* edges of the pieces (Figure 3). When the glue is dry, you can carefully “peel away” any excess.

Because you have to spread a lot of glue, I like to buy myself time by using white glue instead of yellow glue. White glue sets up slower, which helps when there are a lot of box joints, like on the sharpening box.

An “acid” brush (available at most hardware stores) makes it a little

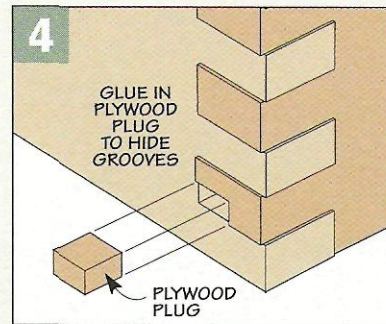

easier to spread the glue (Figure 3a). And go light on the glue. Even a little bit will create a strong hold. And when you're ready to clamp up the box, check the box below for a few tips.

Finally, to hide the holes where the grooves for the drawer bottoms come through, cut some plywood plugs (they'll match the plys) and glue them in place (Figure 4).

Clamping Tip

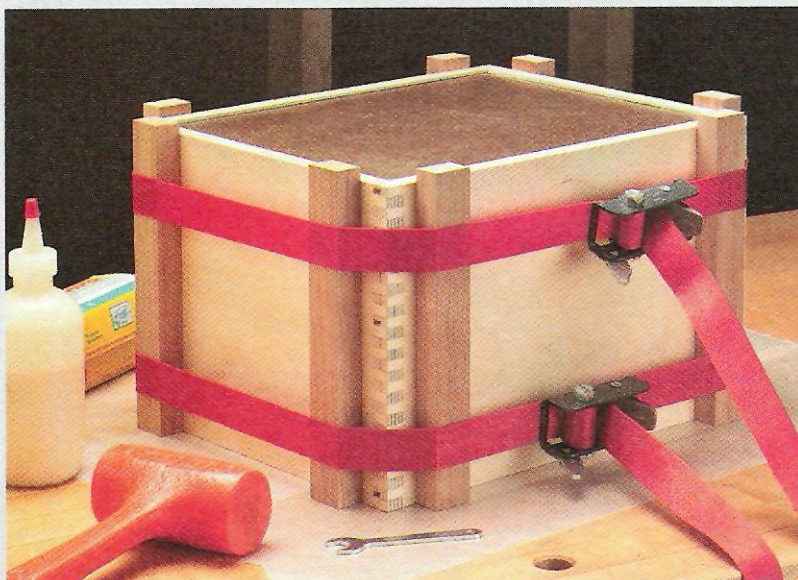

Clamping up a project with box joints can be a little tricky. Because the ends of the box joint fingers stand proud of the sides, you can't really apply clamps directly on the corners. The answer is to use clamping blocks that will allow you to position the clamps close to the joints (photo at left).

Keep in mind that each joint needs to be clamped in two directions in order to pull the pieces together. So you'll need a minimum of four clamps for even the smallest project. Bar clamps work well because they allow you to concentrate the clamping pressure in a straight line. For small projects like the sharpening box, I use band clamps.

On the sharpening box, the top and bottoms help keep everything square. If your project doesn't have a top or bottom, it's a good idea to use a squaring form made from a piece of foam or particle board to keep things aligned.

Plank-Top Workbench



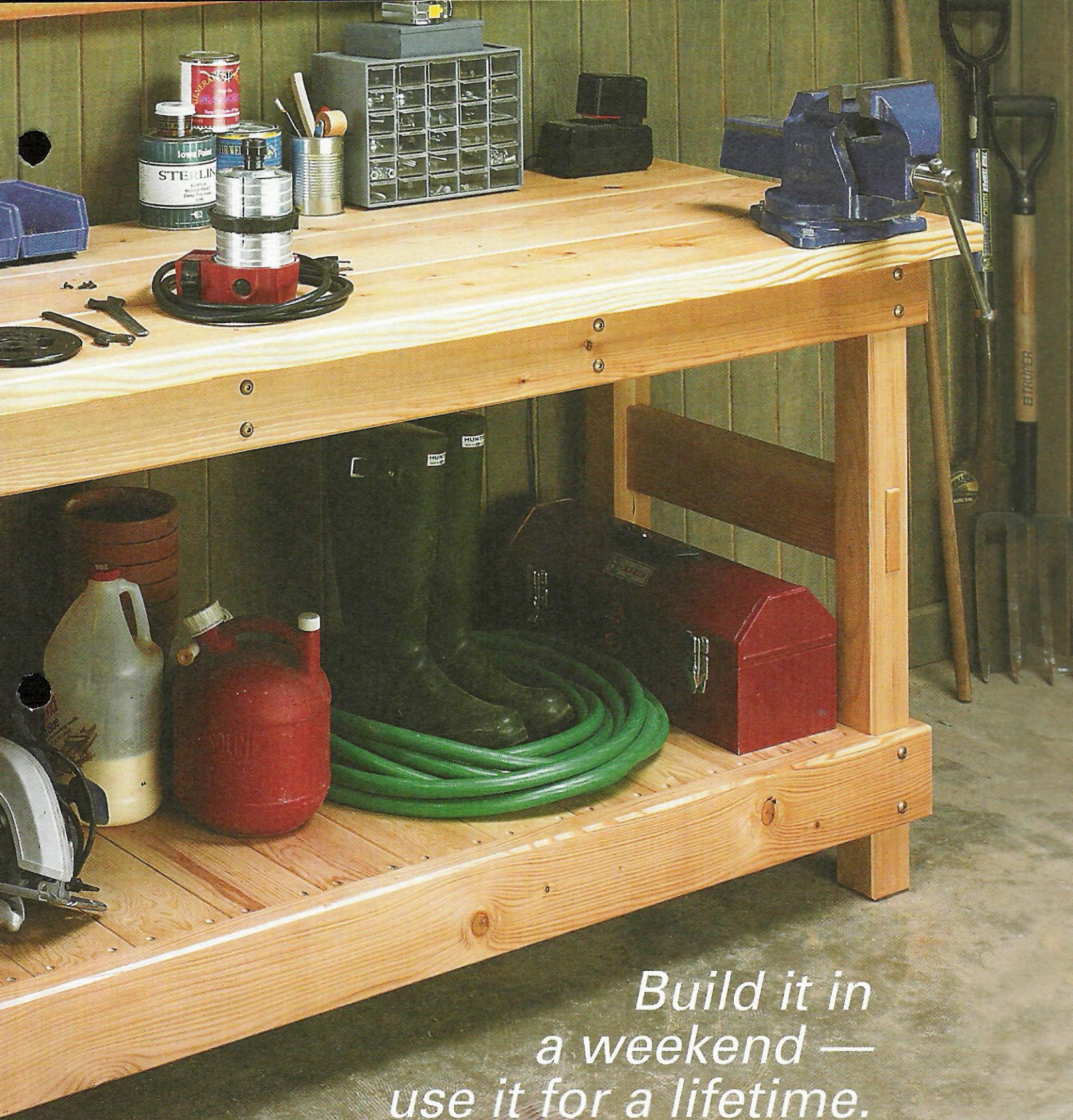

*Build it in
a weekend —
use it for a lifetime.*

A workbench you can build in a weekend. That was our main goal when we started designing the bench you see here. And we succeeded.

But a bench that can be built in a weekend isn't much use if it doesn't hold up over the long haul. So as you can see, we made sure to design this one to be rugged enough to stand up to heavy-duty hammering, sawing,

grinding, pounding, and just about any other form of punishment you can dish out to a bench.

Cost — One of the best things about this bench is that building it won't break the bank. We used inexpensive, commonly available construction lumber for the entire bench, including the top. Then with the money we saved, we bought a nice machinist's vise to install on the top.

Ends

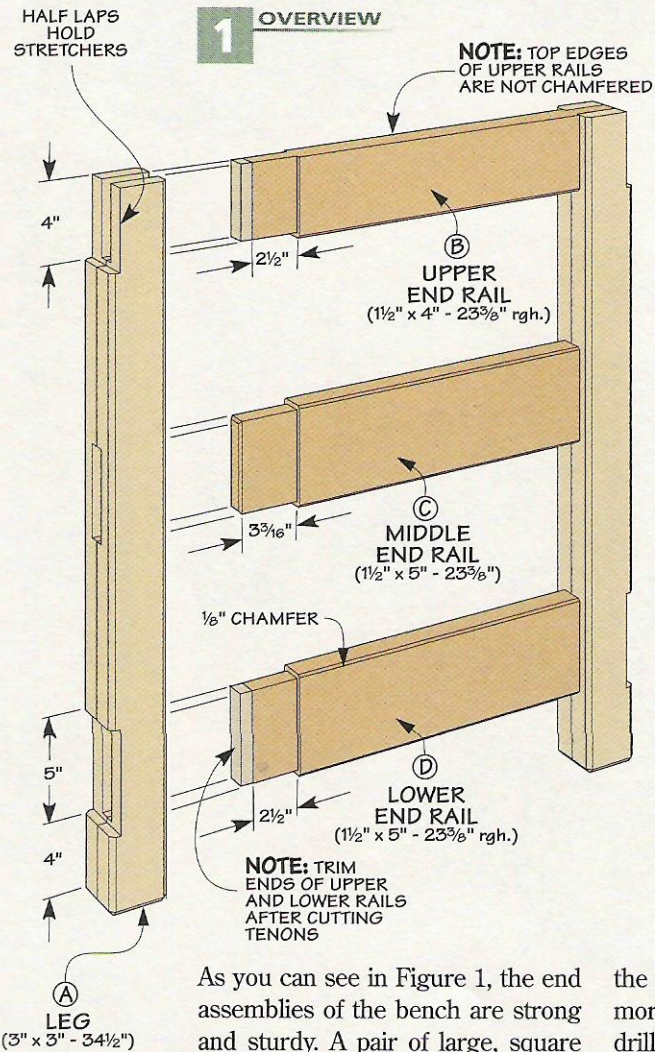

As you can see in Figure 1, the end assemblies of the bench are strong and sturdy. A pair of large, square legs are joined to three rails with mortise and tenon joints. But apart from the solid construction, the interesting thing about this bench is

the way I went about making the mortises for the rails. Instead of drilling or chopping out the mortises, I cut them out on the table saw. Sounds impossible? Let me explain.

Each leg is glued up out of two separate pieces. But instead of

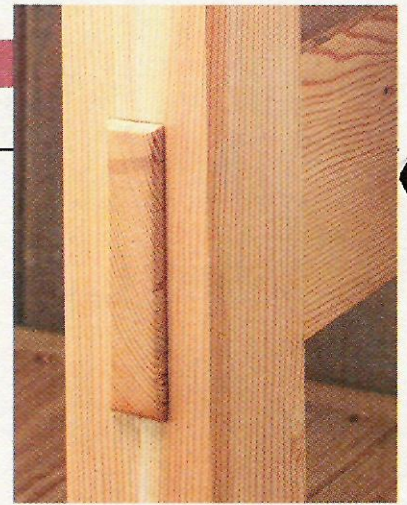
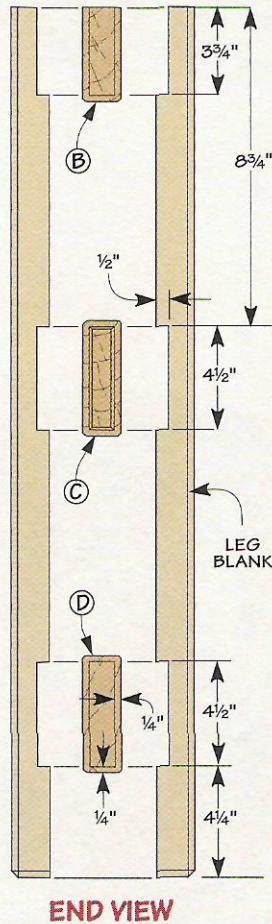

▲ **Through Tenons.** A few cuts on the table saw are all it takes to make perfectly sized mortises for the through tenons of the bench.

making the mortises after the legs were glued up, I cut dadoes on the inside face of both halves of the leg beforehand. This way, you end up with perfectly sized mortises once the legs are glued up.

Legs - To make the legs, you can start by cutting out eight blanks from 1 1/2"-thick stock for the leg halves. I cut these blanks to exact length, but I made them a little wider than necessary so that I could plane the legs down to finished width (3") after they were glued up.

When you've finished cutting all the blanks, you can go ahead and cut the dadoes that will make up the mortises (Figures 2 and 2a). I used the rip fence as a stop when cutting the dadoes to ensure that each pair of dadoes would line up when gluing the leg blanks together.

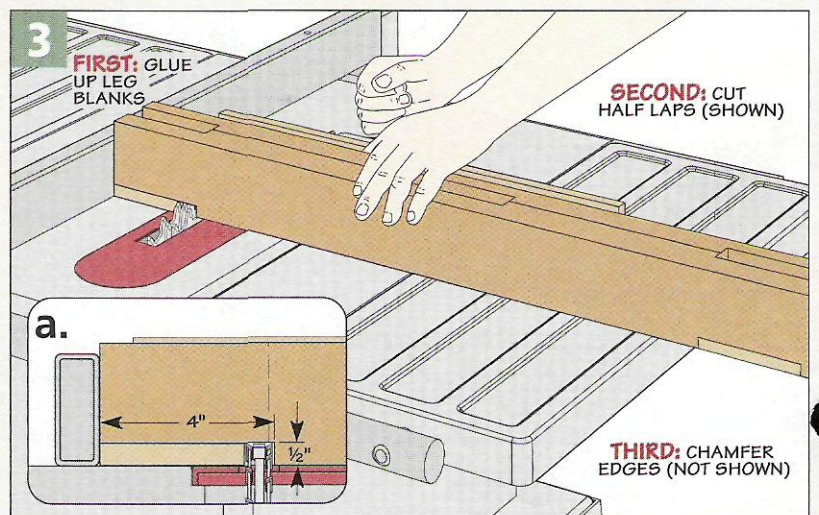
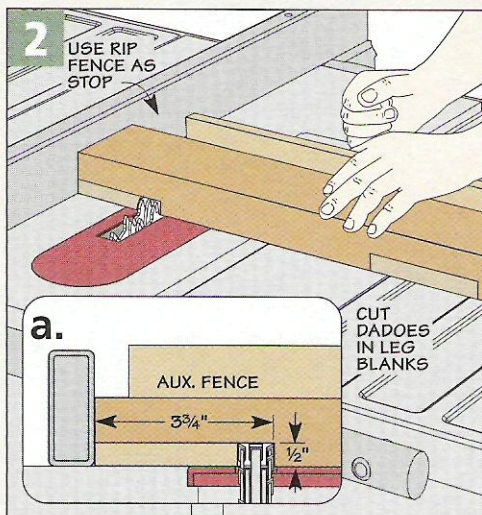

When it comes to gluing up the leg halves, the trick is keeping all the dados aligned while you're clamping the pieces together. To do this, I used some wood "keys." (Take a look at the box below to see what I'm talking about.) I simply cut some blocks of hardwood to fit in the mortises in the legs. Then I chamfered the edges and rubbed paraffin wax on the surfaces of the keys so they wouldn't get glued to the legs.

After the glue is dry, you can remove the clamps and the keys and square up the legs by planing them down to their finished width.

Half Laps – Before moving on to making the end rails, there are a couple of things left to do on the legs. First, you'll need to cut a couple of half laps on one face of each leg to hold the stretchers that will be added later. As you see in Figures 3 and 3a, the rip fence can be used as a stop to position these half laps, just as you did when cutting the dados for the mortises. Next I routed a chamfer on the edges and the bottom of each leg.

Rails – With the legs complete, the next step is to add the end rails. At first glance, these rails look identical. But if you take a closer look at

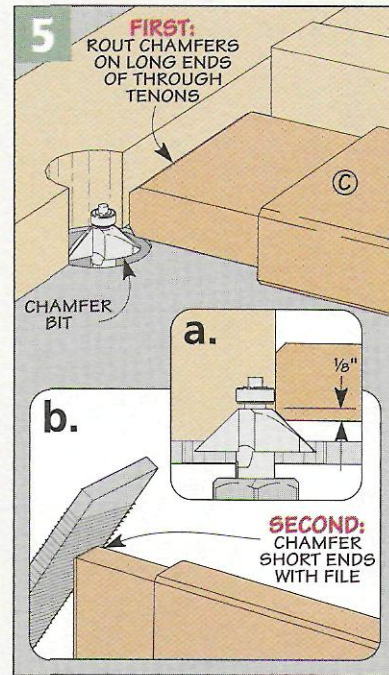
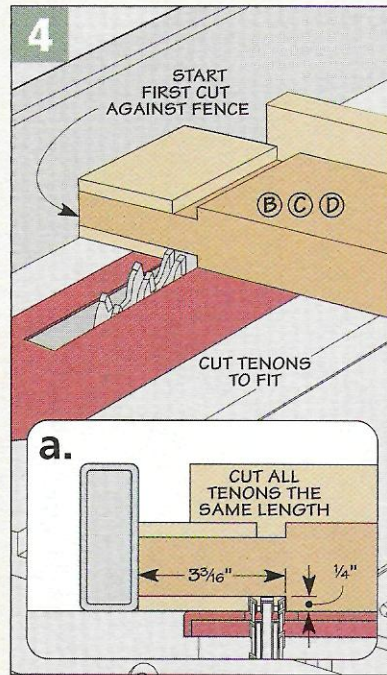
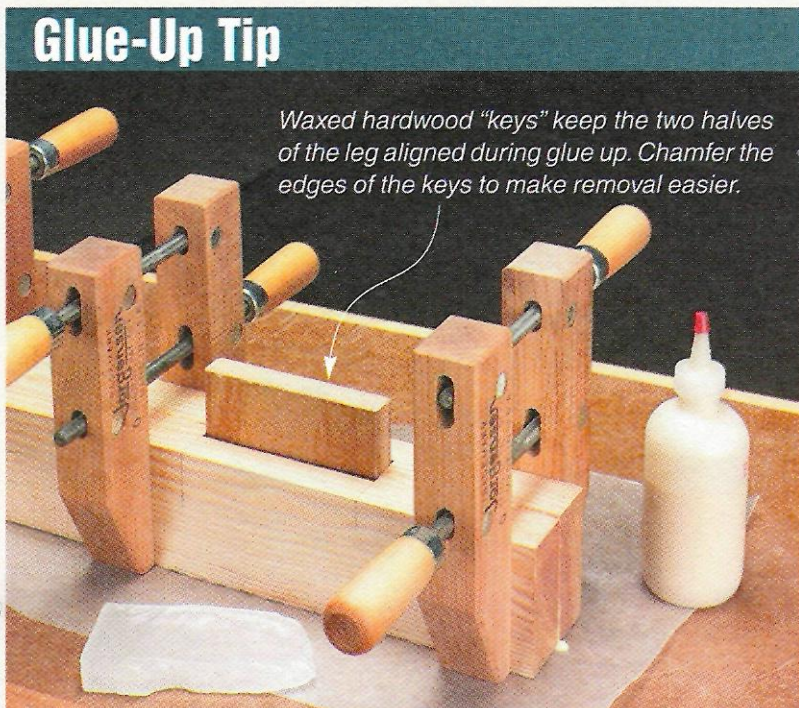

Figure 1, you'll see that there are some slight differences. For one thing, the upper rails are slightly narrower than the lower and middle rails. And the middle rails have through tenons that stand proud of the legs while the tenons on the upper and lower rails are shorter so they end up flush with the half laps.

Don't let all this confuse you though. To make things a little sim-

pler, I started off by cutting all the blanks for the rails to the same length (23³/₈"). This allowed me to cut identical *length* tenons on the ends of all the rails, as shown in Figures 4 and 4a.

Before assembling the rails and legs, I chamfered the ends of the tenons on the middle rails using a router and a file (Figure 5). Then you can trim the tenons on the upper and lower rails to length (Figure 1). Once this is done, all you have to do is rout a chamfer on the edges of the rails (except for the top edges of the upper rails). Now you can glue up the end assemblies, making sure to check each one for square.



Materials & Hardware

A Legs (4)	3 x 3 - 34 ¹ / ₂
B Upper End Rails (2)	1 ¹ / ₂ x 4 - 22
C Middle End Rails (2)	1 ¹ / ₂ x 5 - 23 ³ / ₈
D Lower End Rails (2)	1 ¹ / ₂ x 5 - 22
E Upper Stretchers (2)	1 ¹ / ₂ x 4 - 90
F Lower Stretchers (2)	1 ¹ / ₂ x 5 - 90
G Cross Rails (3)	1 ¹ / ₂ x 4 - 21
H Front/Back Cleats (2)	3/4 x 1 ¹ / ₂ - 82
I End Cleats (2)	3/4 x 1 ¹ / ₂ - 17
J Slats (15)	3/4 x 5 ¹ / ₂ - 21
K Top Planks (3)	1 ¹ / ₂ x 9 - 95

- (74) #8 x 2" Fh Woodscrews
- (30) #8 x 3" Fh Woodscrews
- (28) 5/16" x 4" Construction Lag Screws

Plank Top & Shelf

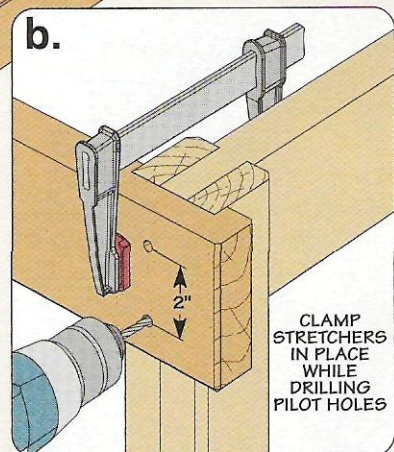
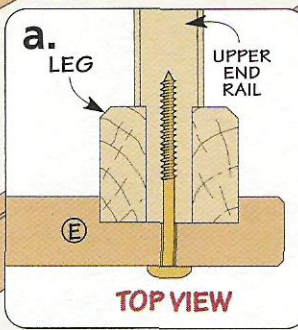
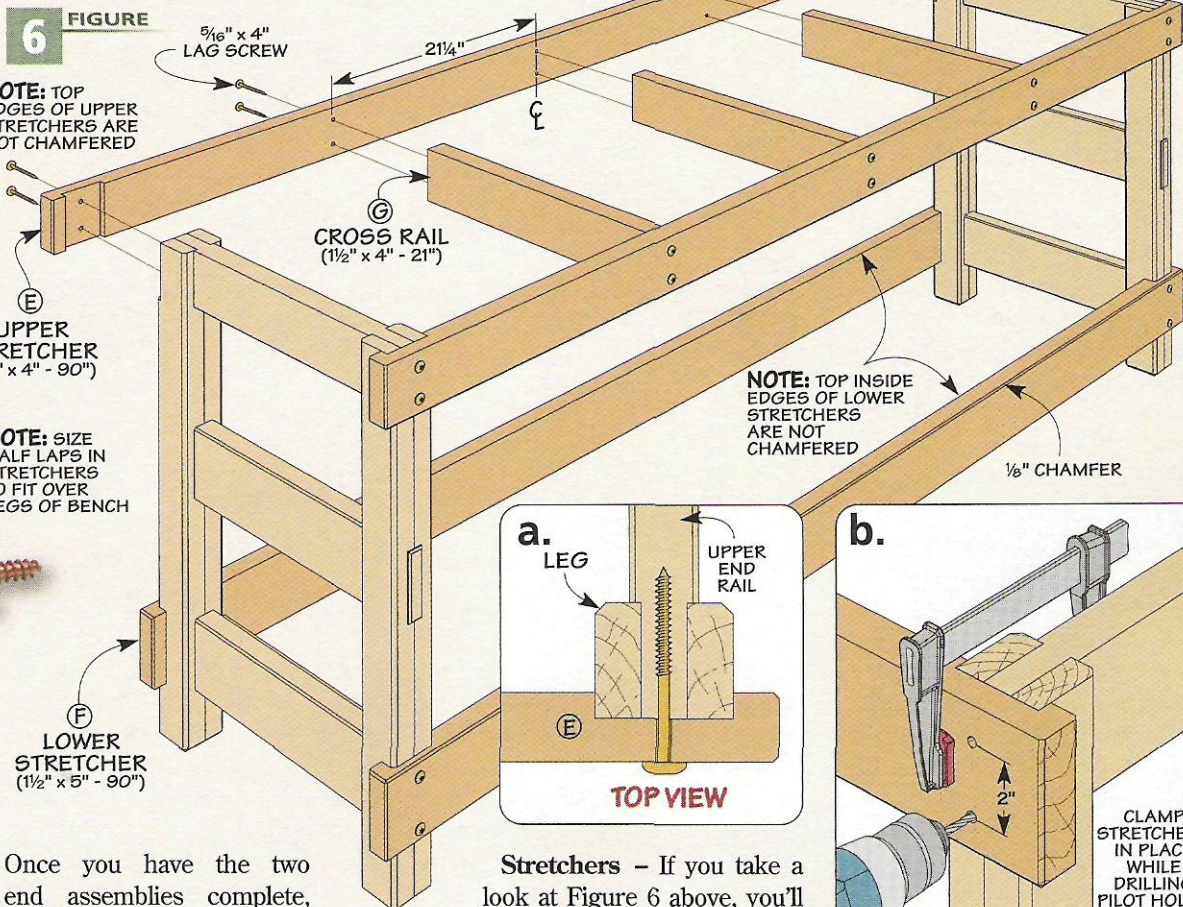

Stretchers – If you take a look at Figure 6 above, you'll see that the stretchers fit into the half laps that you cut earlier on the legs. Half laps are also cut in the stretchers, creating a solid, interlocking joint. In order to get a good fit, start by sizing the width of the upper and lower stretchers to match the half laps in the legs of the bench. Once you've got the stretchers cut to size, you can cut the half laps

Once you have the two end assemblies complete, building the rest of the workbench really goes along pretty quickly. The ends are connected with two pairs of stretchers — one at the top and one near the bottom of the legs. These stretchers serve a dual purpose. The upper stretchers help to support the top of the bench and the lower stretchers support a shelf. But more on that later.

this with a dado blade on the table saw, using the rip fence as a stop to position the ends of the half laps (Figures 7 and 7a). The stretchers are pretty long, so you may want to use an outrigger stand next to your table saw to help support them.

After chamfering the edges and ends of the stretchers as shown in Figure 6, you can clamp the stretchers to the ends of the bench and drill pilot holes for the screws (Figure 6b). I used some large, construction lag screws for attaching the stretchers (see photo in margin at left). These screws are not only strong, but they have a tough, rugged appearance that matches the overall look of the bench.

Cross Rails – To help support the top of the bench, I added three cross rails between the two upper stretchers, as you can see in Figure 6. These cross rails are simply cut to

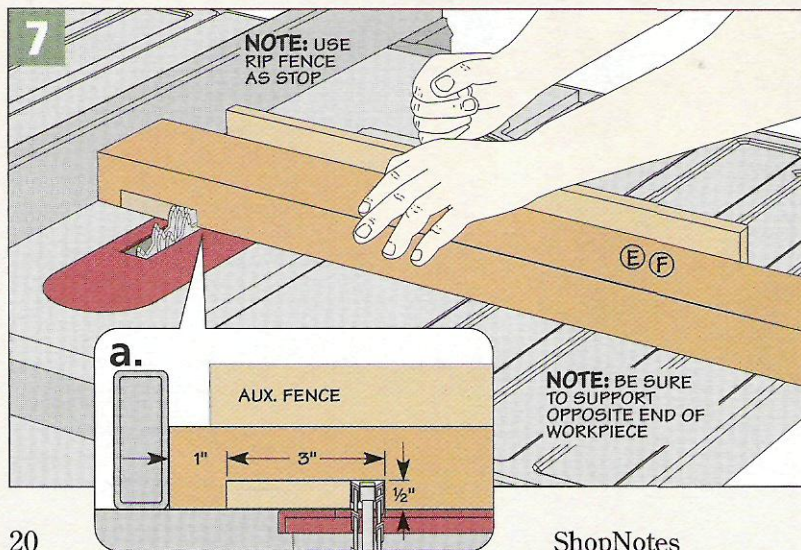

length and then screwed in place between the stretchers, using the same construction lag screws.

Shelf – To create some storage space under the benchtop, I added a shelf to the lower stretchers and rails. The shelf is really just a series of slats that are supported by cleats attached to the inside faces of the lower stretchers and rails.

You can start by cutting the cleats to size and screwing them in place. The goal here is to position the cleats so the slats will end up flush with the top edges of the lower stretchers and rails. To make this easier, I built a quick positioning guide for installing the cleats.

All I did was cut a small block from the same stock that I used for the shelf slats. Then I fastened this to a wider piece of wood. With the guide clamped in place, all you have to do is butt the cleat up to the bottom of the guide and screw it in place. Figures 8 and 8a show you what I'm talking about.

Once the cleats are in place, you can cut the 15 shelf slats to identical size. After chamfering the edges of the slats, I set them in place on the cleats. Start at the center of the bench and work your way out to the ends, leaving a 1/8" gap between each slat (Figure 9).

When you reach the ends, you'll have to trim the end slats to width and notch the corners so they fit

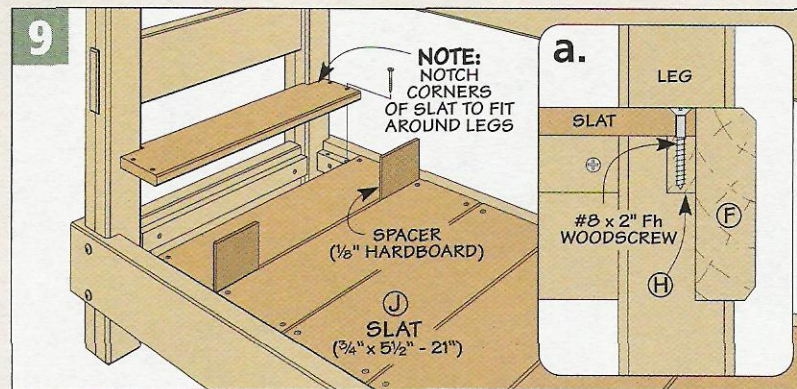
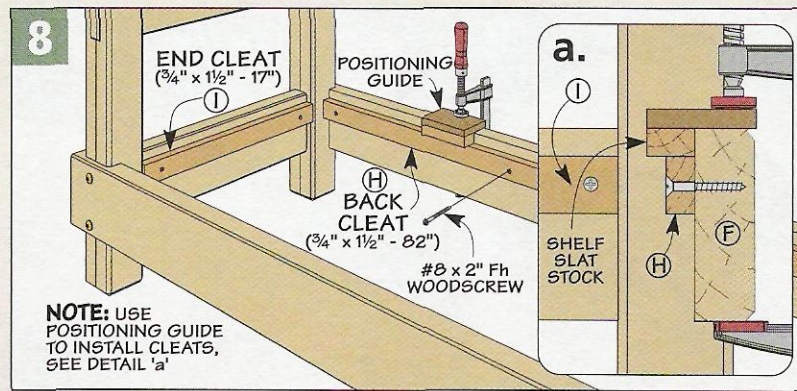

around the legs of the bench. Once this is done and the slats are fitted into position, you can go ahead and screw each slat in place.

Top – At this point, the only thing left to do to complete the bench is to add the top. To avoid the time and hassle involved in making a glued-up top, I used three separate planks. These are just cut to size and then the top edges are chamfered.

As you can see in Figure 10 below,

the planks are simply screwed in place, leaving a 1/8" gap in between each one. The only thing worth mentioning here is that in order to avoid hitting the large lag screws that connect the stretchers and rails, I offset the screws that fasten down the top planks (Figure 10).

Finally, you can apply a finish to the bench and then add a vise of your choice.

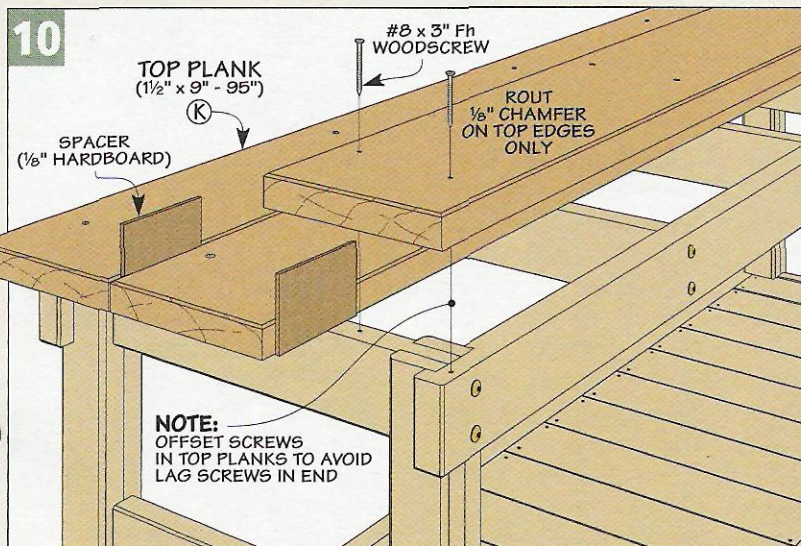

Online Extra
ON THE WEB
Super-Size It
 For instructions on expanding the bench to 12 feet (or longer), visit our website at www.ShopNotes.com and click on the online extras button.

Plank Top. With a top made of three separate planks, this bench is rugged enough to stand up to anything.



Machinist's Vises

Why every woodworking shop should have one.

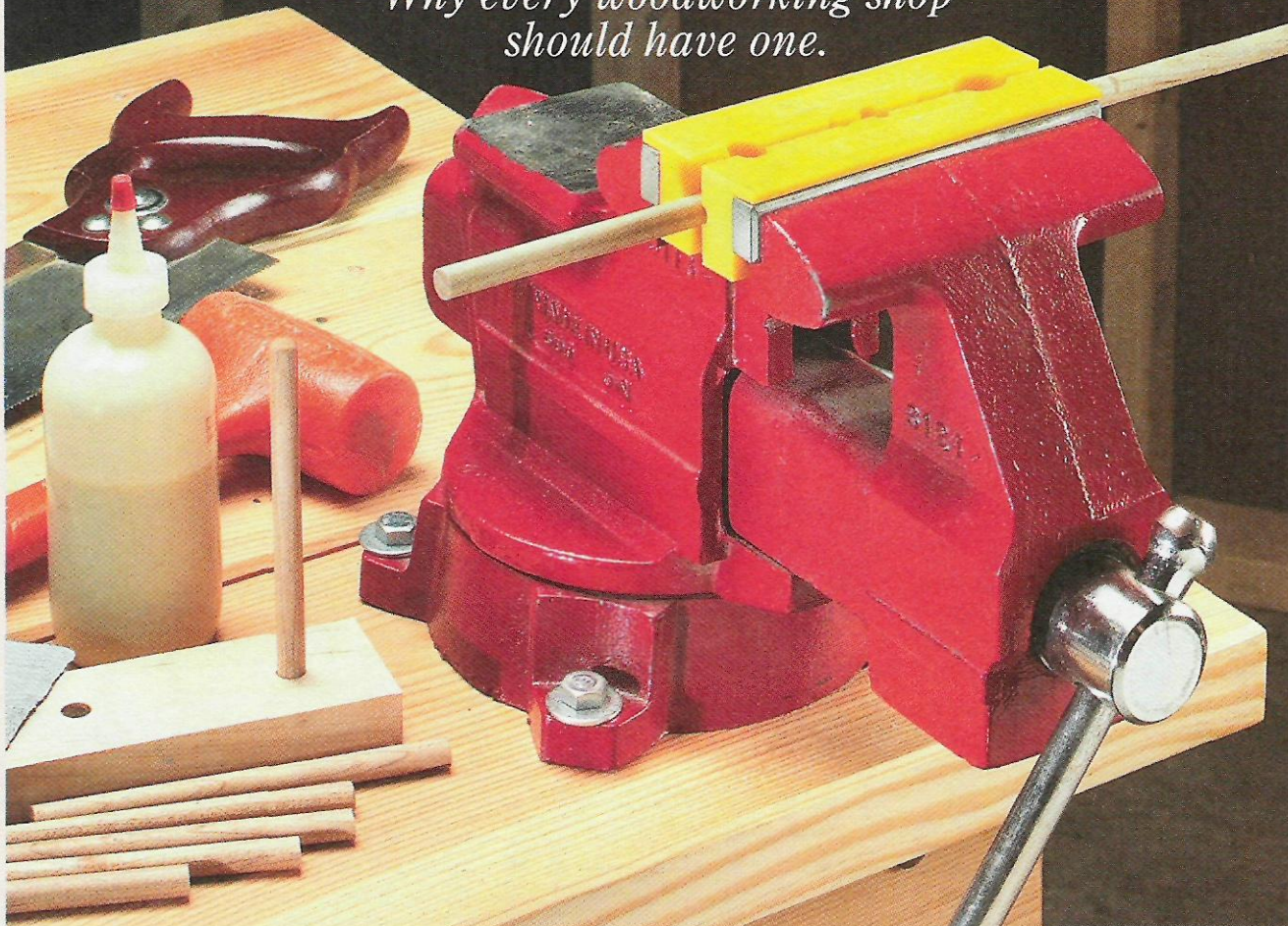

We've all done it. Whether it was while cutting a length of threaded rod or sharpening the blade from your lawn mower, at some time you've probably used your woodworking vise for tasks other than clamping wood.

Not that there's anything "wrong" with this. But the fact is, for some jobs a woodworking vise just doesn't cut it. And that's when you'll wish you had a machinist's vise.

Strength - The main difference between a machinist's

vise and a woodworking vise is holding strength. Most woodworking vises consist of little more than a screw and a couple of wood-faced jaws guided by a pair of steel rods. But the jaws of a machinist's vise are an integral part of the body of the vise. Their rigid, box-like structure results in a vise capable of much greater clamping pressure. Which makes a machinist's vise useful for all sorts of applications.

Jaws - Another major difference between a machinist's vise and a woodworking vise is in the jaws. The jaws of a machinist's vise are designed primarily to hold metal objects without slipping. Most machinist's vises have hardened steel jaw faces. And the surface of the jaws is typically knurled to provide a non-slip grip. These jaws are usually replaceable

so that you can change them out if they get damaged or chewed up through use.

Size - Since machinist's vises aren't too complicated, shopping for one may seem like a no-brainer. But it's important to select a vise that is suited to the type of work you have in mind. And the first decision you will have to make is size. Machinist's vises are usually designated by the width of their jaws. For a home shop, a vise with 4" or 5" jaws should be adequate.

Additional Features - Aside from the size of the vise, there are a few other features that you might want to consider when selecting a vise. Most of the better machinist's vises have a swiveling base. This is handy because it allows you to move the vise into the most comfortable working position. A clamp locks the base in place.



◀ **Anvil.** A flat, machined surface at the back of this vise is perfect for peening over rivets.

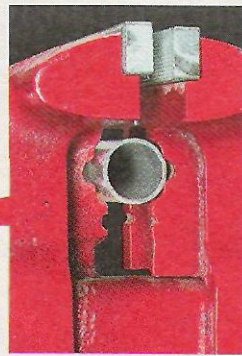

▲ **Pipe Jaws.** A secondary set of jaws on this vise can be used to hold pipe or rods.

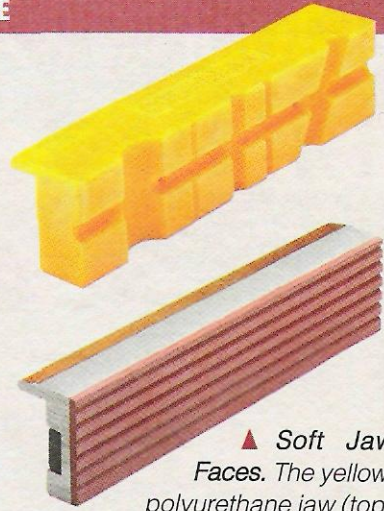

▲ **Soft Jaw Faces.** The yellow, polyurethane jaw (top) is grooved to hold round stock. The lower jaw is lined with rubber. Both are held in place with magnets.

Some vises have a flat, machined surface behind the jaws that functions as a “mini” anvil for riveting or peening, see lower left photo on opposite page. Other vises may have a set of secondary jaws below the main jaws for holding pipe (see photo above).

Auxiliary Jaws – An easy way to get more out of your machinist’s vise is to invest in a set of auxiliary “soft” jaw faces (see photo in upper right corner). These jaw faces are made out of polyurethane or lined with rubber so they don’t mar the workpiece you’re holding. They simply slip over the main jaws of the vise and are held in place with magnets. These jaw faces are available in different lengths to suit your vise.

If you work with metal, you might want to get a set of jaw faces that are designed to bend metal, see lower right photo. Like the soft jaw faces, these simply slip over the main jaws of your vise and can be used to bend thin steel and soft metals.

MOUNTING A VISE

Compared to a woodworking vise, mounting a machinist’s vise is a piece of cake. Most of them simply bolt directly to the top of a workbench. The most common spot for a machinist’s vise is at the front, right-hand corner of a bench. With a vise in this location, large or oddly shaped items can overhang the end of the bench while being held in the jaws of the vise.

Of course, you may not want a machinist’s vise permanently taking up space on the top of your bench. In this case, a good solution is to mount the vise to a piece of plywood with a cleat attached to the bottom, see lower left photo. This way, you can clamp the vise in the jaws of your woodworking vise when you want to use it.

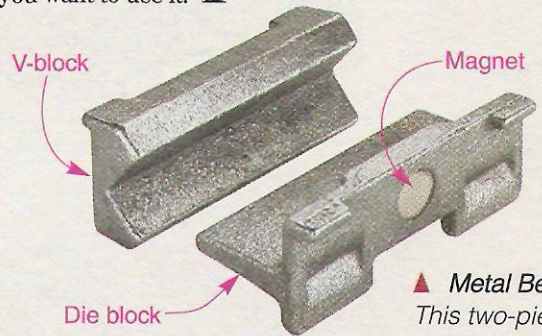

▲ **Metal Bender.** This two-piece jaw set consists of a die that forces the metal against a V-block, creating a perfect 90° bend. See page 35 for sources.



Part-Time Vise. A piece of plywood and a cleat allow you to mount a machinist’s vise to your woodworking bench.

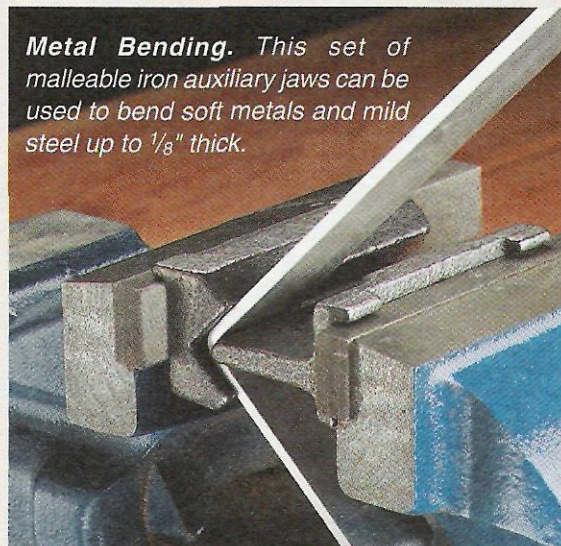

Metal Bending. This set of malleable iron auxiliary jaws can be used to bend soft metals and mild steel up to 1/8" thick.

Dual Tool Station

Finally, a tool station dedicated to providing support for both a miter saw and a planer.

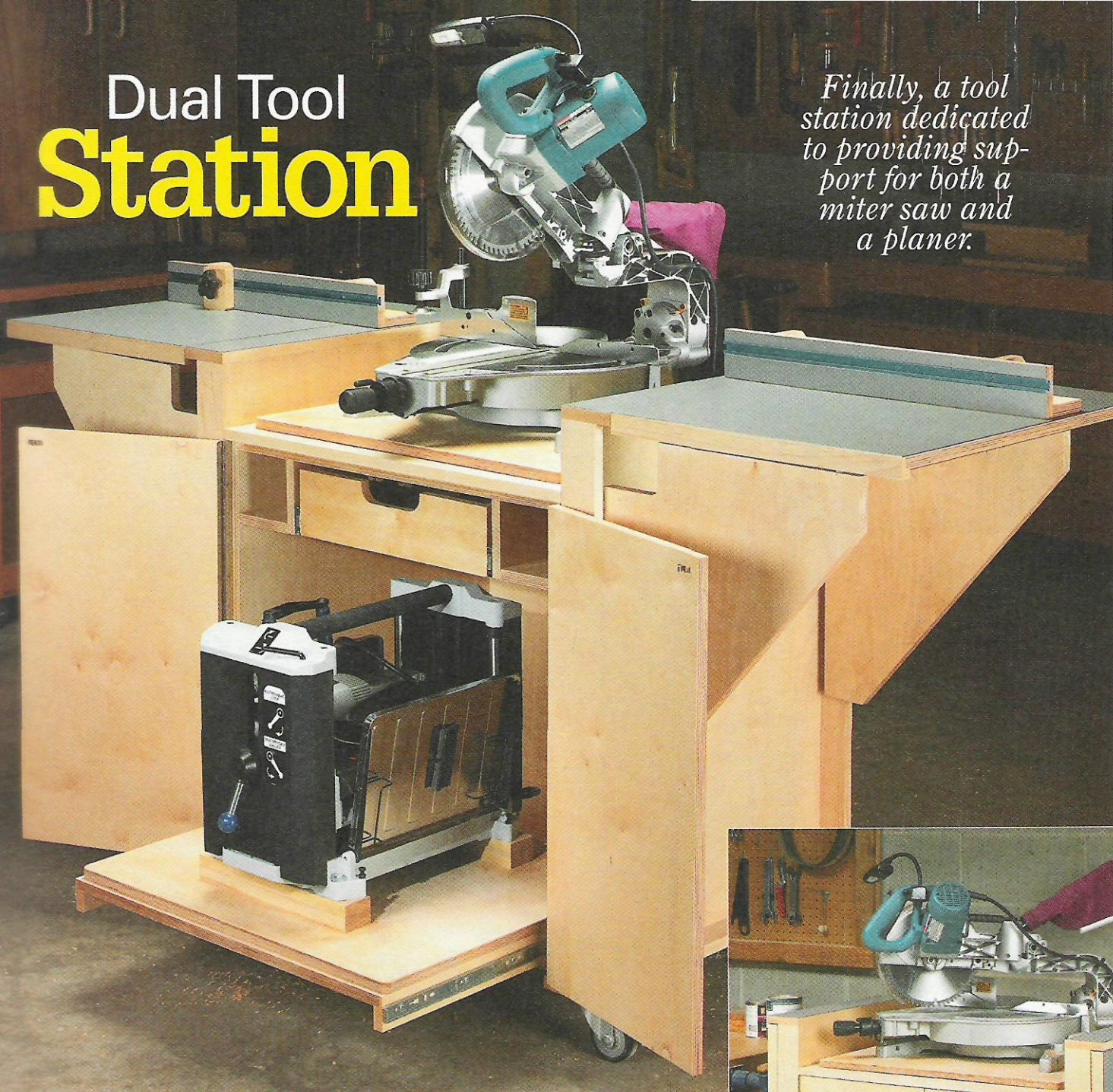

Making use of a miter saw or planer is often a compromise. For a long time I simply set one or the other on the top of my workbench, setting up makeshift supports when I needed to work with long stock. But the dual tool station shown above allows me to make better use of both tools without tying up my bench.

Extension Wings – To provide extra support when working with long stock on either the miter saw or planer, there's an extension wing and auxiliary fence (for the miter saw) on each side of the station. To save space, the extension wings fold down to the sides and the fences store inside (inset photo at right).

Storage – Besides the fences, there's also a shelf for storing the tool you're not using, as you can see above. The shelf slides out to make it easy to get the tool in and out. Finally, a deep drawer on full-extension slides holds manuals, accessories, and anything else you might need to use with your miter saw or planer.

EXPLODED VIEW

OVERALL DIMENSIONS:
 77³/₄"W x 25³/₄"D x 38¹/₂"H
 (with wings up)
 38"W x 25³/₄"D x 38¹/₂"H
 (with wings down)

LAMINATED EXTENSION WING SWINGS UP TO PROVIDE SOLID, DURABLE SUPPORT SURFACE WHEN CUTTING OR PLANING LONG STOCK

PLYWOOD BASE LOCKS TOOL IN POSITION ON TOP OF CABINET

REMOVABLE FENCE KEEPS WORKPIECES ALIGNED WITH MITER SAW FENCE

AUXILIARY FENCES STORE INSIDE CABINET WHEN NOT IN USE

FURNITURE GLIDES ACT AS LEVELERS FOR EXTENSION WINGS

DRAWER PROVIDES CONVENIENT STORAGE FOR ACCESSORIES AND SUPPLIES

EXTENSION WING RESTS ON FOLD-OUT SUPPORTS

PLYWOOD DOORS ENCLOSE STORAGE AREA

SLIDE-OUT SHELF RIDES ON ³/₄"-EXTENSION METAL DRAWER SLIDES

HEAVY-DUTY, LOCKING SWIVEL CASTERS ADD MOBILITY

ShopNotes
 GO ON-LINE EXTRAS
 To download a free cutting diagram for the Dual Tool Station, go to:
www.shopnotes.com

Hardware

- (38) #8 x 1³/₄" Fh Woodscrews
- (16) #12 x ³/₄" Ph Woodscrews
- (4) 3" Locking Swivel Casters
- (2) 1¹/₂" x 27¹/₈" Piano Hinges w/screws
- (2) 4" Sash Pulls w/screws
- (2) Bullet Catches w/screws
- (8) ¹/₄" Threaded Nylon Inserts
- (8) ¹/₄" x 7¹/₈" Levelers
- (4) 1¹/₂" x 16⁷/₈" Piano Hinges w/screws
- (2 Pr.) Flush Hinges w/screws
- (1 Pr.) Full-Extension Metal Drawer Slides (22" Long) w/screws
- (1 Pr.) ³/₄"-Extension Metal Drawer Slides (22" Long) w/screws
- (2) T-Track (23" Long) w/screws
- (14) #8 x 1¹/₂" Fh Woodscrews
- (4) ⁵/₁₆" Threaded Brass Inserts
- (5) ⁵/₁₆" Flat Washers
- (4) ⁵/₁₆" x 1¹/₂" Studded Knobs
- (1) ⁵/₁₆" Through Knob
- (1) ⁵/₁₆" x 1¹/₂" Flange Bolt

Materials

A Top/Bottom (2)	23 ⁵ / ₈ x 29 ¹ / ₄ - ³ / ₄ Ply.	P Drawer Sides (2)	4 ¹ / ₈ x 21 ³ / ₄ - ³ / ₄ Ply.
B Sides (2)	23 ⁵ / ₈ x 28 - ³ / ₄ Ply.	Q Drawer Bottom (1)	21 x 15 ¹ / ₂ - ¹ / ₄ Ply.
C Back (1)	30 x 28 - ³ / ₄ Ply.	R Slide-Out Shelf (1)	22 x 27 - ³ / ₄ Ply.
D Fence Holder Sides (2)	4 ³ / ₄ x 23 ¹ / ₄ - ³ / ₄ Ply.	S Shelf Sides (2)	³ / ₄ x 2 - 22
E Fence Holder Btms. (2)	4 ³ / ₄ x 23 ¹ / ₄ - ³ / ₄ Ply.	T Tool Base (2)	22 x 27 ¹ / ₂ - ³ / ₄ Ply.
F Worksurface (1)	23 ¹ / ₄ x 30 - ³ / ₄ Ply.	U Cleat (1)	1 ¹ / ₄ x 2 - 15
G Edging (2)	³ / ₄ x ³ / ₄ - 30	V Filler Strips (4)	1 ¹ / ₄ x 2 - 6 ¹ / ₄
H Housing Back (2)	24 x 33 - ³ / ₄ Ply.	W Fence Face (2)	3 x 23 - ³ / ₄ Ply.
I Housing Sides (4)	³ / ₄ x 2 ⁵ / ₈ - 33	X Fence Base (2)	3 x 23 - ³ / ₄ Ply.
J Housing Top/Btm. (4)	³ / ₄ x 3 ⁷ / ₈ - 24 ³ / ₄	Y Fence Spt. Blocks (4)	2 ¹ / ₂ x 3 - ³ / ₄ Ply.
K Doors (2)	14 ¹³ / ₁₆ x 27 ⁷ / ₈ - ³ / ₄ Ply.	Z Stop Block (1)	³ / ₄ x 2 ¹ / ₂ - 3
L Wing Supports (4)	18 x 19 ⁷ / ₈ - ³ / ₄ Ply.		
M Extension Wings (2)	20 x 24 - ³ / ₄ Ply.		
N Wing Edging (4)	³ / ₄ x 1 ¹ / ₄ - 20		
O Drawer Frt./Back (2)	4 ¹ / ₈ x 16 ¹ / ₂ - ³ / ₄ Ply.		

Main Cabinet

The heart of the station is the main cabinet you see in the drawing at right. It's nothing more than an open box with doors on the front. Attached to each side of the cabinet are the housings for the fold-out wing supports. Finally, a pair of compartments on the inside provide storage for the fences that are added later.

Sizing the Cabinet – Since miter saws and planers can vary quite a bit in size, the most important thing to decide is how big the cabinet needs to be. Depending on which tool you're using, the other will need to fit inside the cabinet. And the height of the tables on each tool will affect how tall the housings for the extension wings need to be.

The dimensions for the cabinet shown place the tables of the miter saw and planer at a height of $38\frac{3}{4}$ " once the casters are added — a good working height. And it allows for miter saw and planer tables that measure $4\frac{1}{4}$ " high. This should provide enough interior height to handle most planers and miter saws in the stored position.

Besides the height of the cabinet, you'll also need to consider the depth and width. To get the maximum depth, yet still be able to get the best use out of a standard 4' x 8'

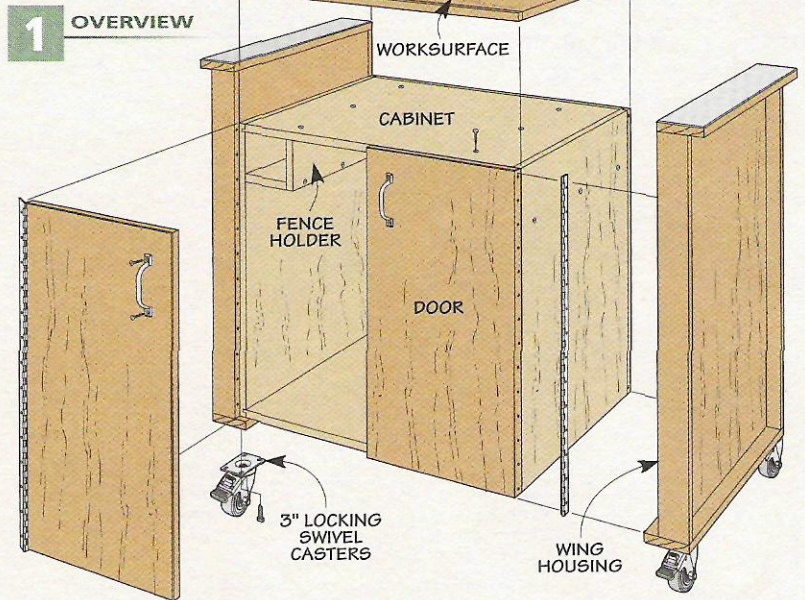

sheet of plywood, the width of the workpieces is just under 24". This allows for an interior depth of $23\frac{1}{4}$ ".

The critical factor for the overall width of the cabinet was the smallest "footprint" I could create with my sliding miter saw. To determine this, I spent a little time swinging the miter saw to the left and then the right, measuring the overall width (and checking the depth at the same time).

For my saw, I chose a position where my sliding miter saw was set to the right and pulled slightly for-

ward. After doing this, I sized the cabinet for an interior width of $28\frac{1}{2}$ ".

Finally, don't forget about the fold-up extension tables on your planer. They can affect the overall width of the cabinet as well. You'll want to make sure they'll fit between the support housings when they're folded down during use. (This was 30" for my cabinet.)

Build a Box – When you cut the top/bottom (A), sides (B), and back (C) to size (Figure 2), be sure to account for the tongue and groove joinery used to assemble the cabinet. You can see this joinery in Figures 2a, 2b, and 2c.

Once the pieces are cut to size, you can cut the grooves in the side pieces and back. Then cut the tongues on the ends and back edges of the top and bottom to fit the grooves, along with a tongue along the back edge of the side pieces.

Fence Holder – After the cabinet is glued up, you can turn your attention to the small cubby holes on the inside of the cabinet for storing the auxiliary fences for the miter saw.

Creating the storage areas is just a matter of cutting a side (D) and bottom piece (E) for each and then screwing them in place, as illustrated in Figures 3 and 3b.

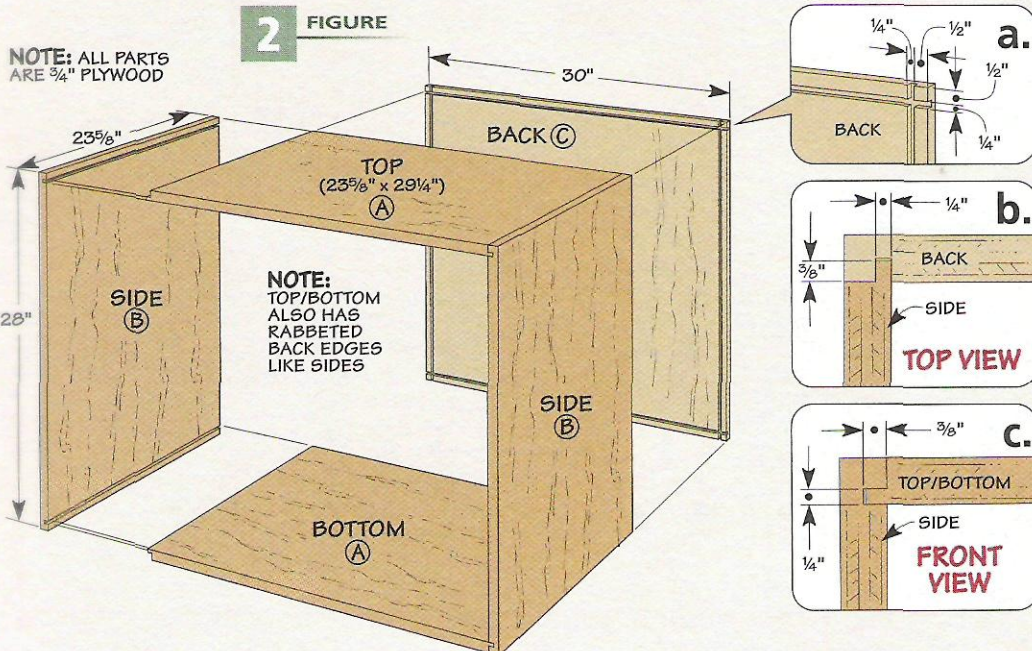

NOTE: ALL PARTS ARE $\frac{3}{4}$ " PLYWOOD

2 FIGURE

NOTE: TOP/BOTTOM ALSO HAS RABBETED BACK EDGES LIKE SIDES

Add a Worksurface – To complete the basic cabinet, all that's left to do is add a worksurface to the top. As you can see in Figure 3, the *worksurface (F)* is just a piece of plywood with *edging (G)* on the front and back. You don't need to worry about edging the sides because they'll be covered up shortly when you add the wing housings.

When sizing the worksurface and edging, keep in mind that it's flush at the back of the cabinet. But it extends *past* the front edge when it's glued in place so that when the doors are added everything is flush (Figure 5).

Wing Support Housing – The housings serve two functions. First, they provide an attachment point for the wings so you can align them with the tables on the miter saw and planer. And second, they create a storage spot for the wing supports that swing out to hold the wings up.

Each housing consists of a plywood *back (H)* wrapped with hardwood *sides (I)* and *top/bottom (J)*, like you see illustrated in Figure 4.

The overall width of the housing matches the depth of the worksurface on the cabinet. As you can see in

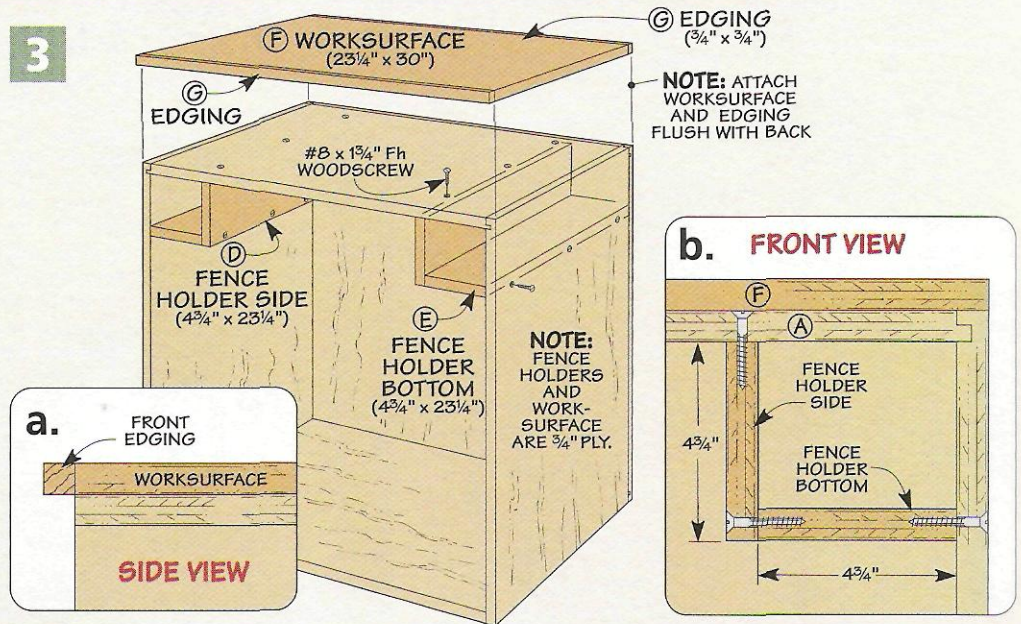
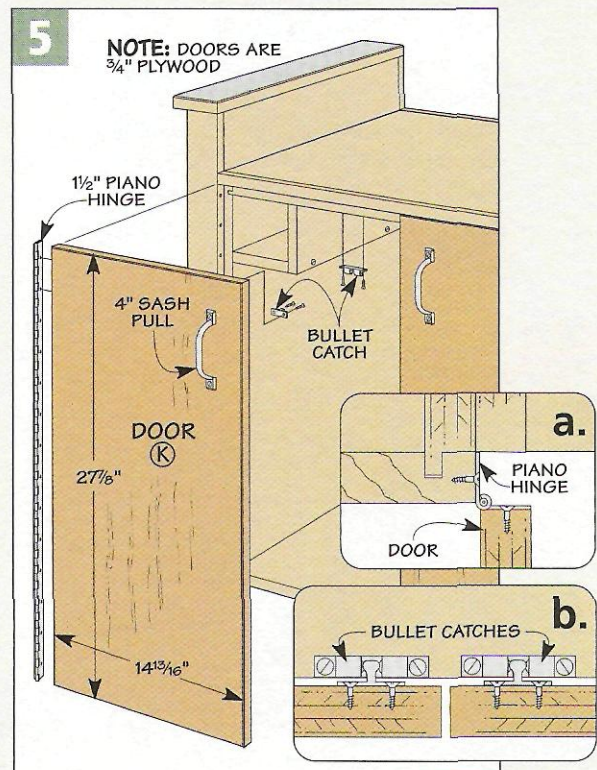
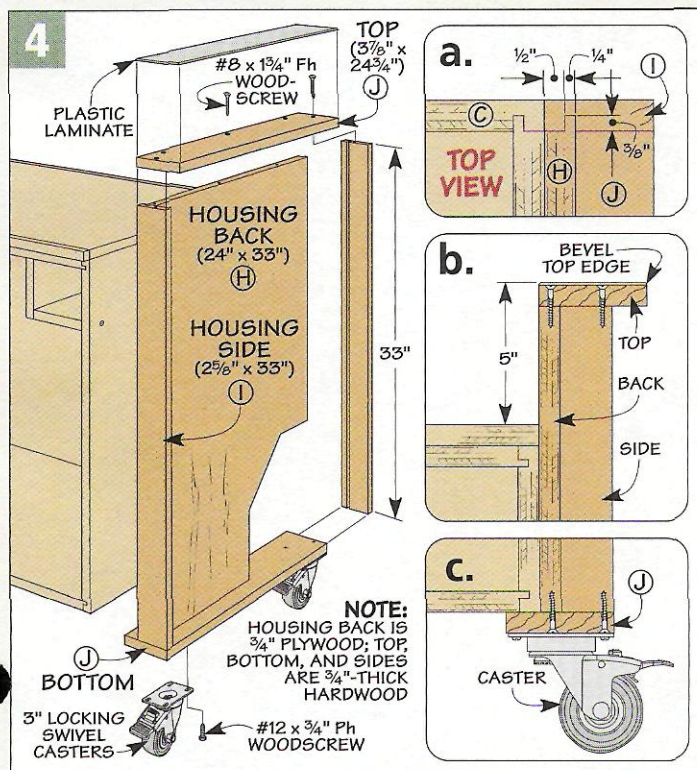

Figure 4c, the bottom piece wraps underneath the cabinet to provide a mounting location for the casters that make the station mobile.

The sides are joined to the back with tongue and groove joinery, while the top and bottom are glued and screwed in place. Once that's complete, you can add plastic laminate to the top piece to provide a smooth, durable surface. I trimmed the laminate flush with a chamfer

bit, as in Figure 4b. Finally, the housings are glued to the sides of the cabinet so they're flush with the back (Figure 4a).

After screwing the casters in place (Figure 4c), you can add the *doors (K)* you see in Figure 5. The doors are just plywood panels attached to the cabinet with piano hinges, as in Figures 5 and 5a. A pair of pulls and bullet catches complete the main cabinet (Figures 5 and 5b).



Extension Wings & Supports

6 OVERVIEW

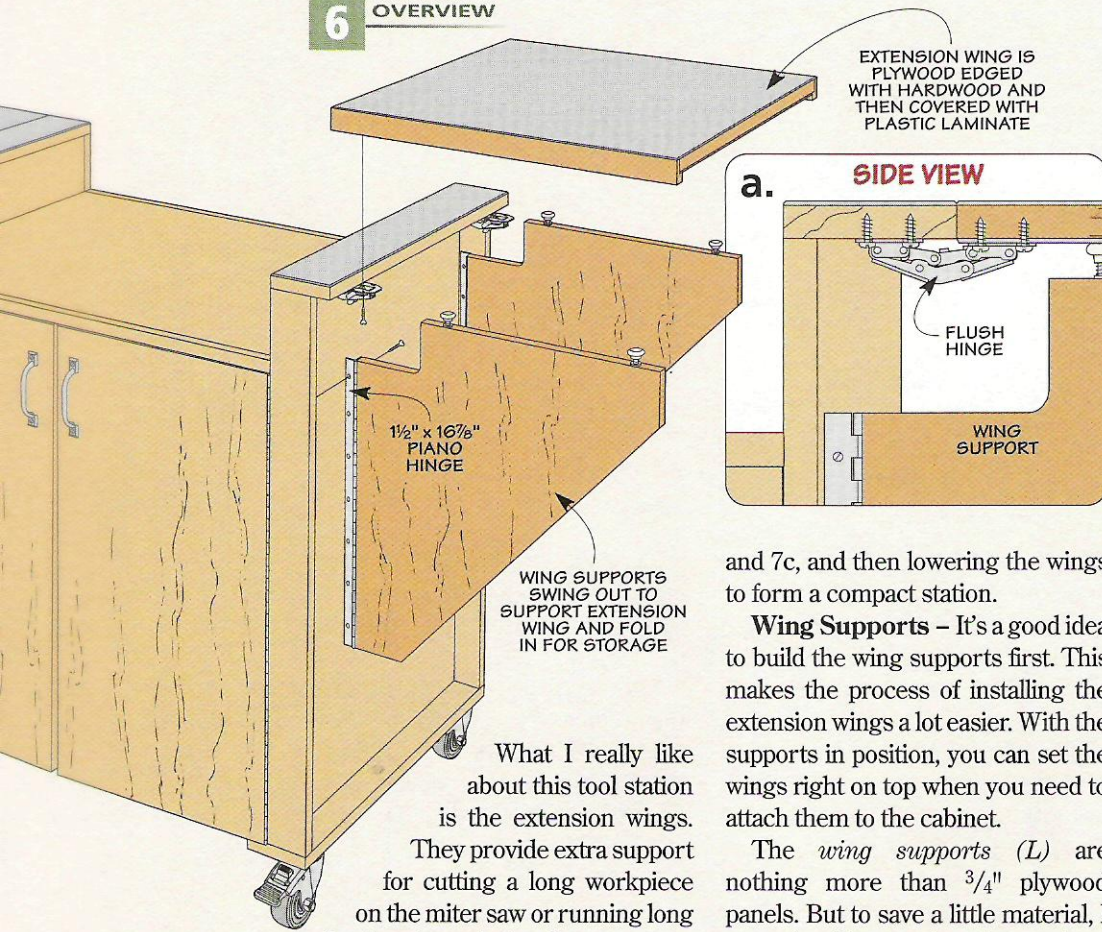

What I really like about this tool station is the extension wings. They provide extra support for cutting a long workpiece on the miter saw or running long lumber through the planer.

But what's even better is how easy it is to store the extension wings out of the way when you don't need them. It's just a matter of swinging the supports in, one right on top of the other, like you see in Figures 7b

and 7c, and then lowering the wings to form a compact station.

Wing Supports – It's a good idea to build the wing supports first. This makes the process of installing the extension wings a lot easier. With the supports in position, you can set the wings right on top when you need to attach them to the cabinet.

The *wing supports* (L) are nothing more than 3/4" plywood panels. But to save a little material, I started with a pair of extra-long blanks and cut each pair of identical supports from them (Figure 7).

A notch in the upper inside corner of each support provides clearance for the hinges as you swing the supports in and out. Once

the notches are complete, use a jig saw to shape each support and then sand the edges smooth.

Add the Levelers – Trying to position the supports on the cabinet so the wings are perfectly level is tough. So to make it easy to level the wings, I added levelers to the top edge of the supports before I installed them (Figure 7a).

This is just a matter of drilling a pair of holes in the top edge for some inserts. After tapping the inserts in place, you can thread the levelers in.

To provide clearance for the two supports when you swing them in, they're offset from each other when you install them. You can see how this works in Figures 7b and 7c.

After installing the hinge on the inside support, screw it in place 1/8" from the back of the housing (Figure 7c). To locate the other support, use a spacer to position the hinge 1" from the inside face of the housing, as illustrated in Figure 7b.

Make the Wings – The *wings* (M) that rest on top of the supports are just a piece of 3/4" plywood with hardwood *edging* (N) along the front and back (Figures 8 and 8b).

To provide the same durable surface as the top edge of the housing, I add matching plastic laminate and trimmed it flush, chamfering the edge as before. Then to prevent any

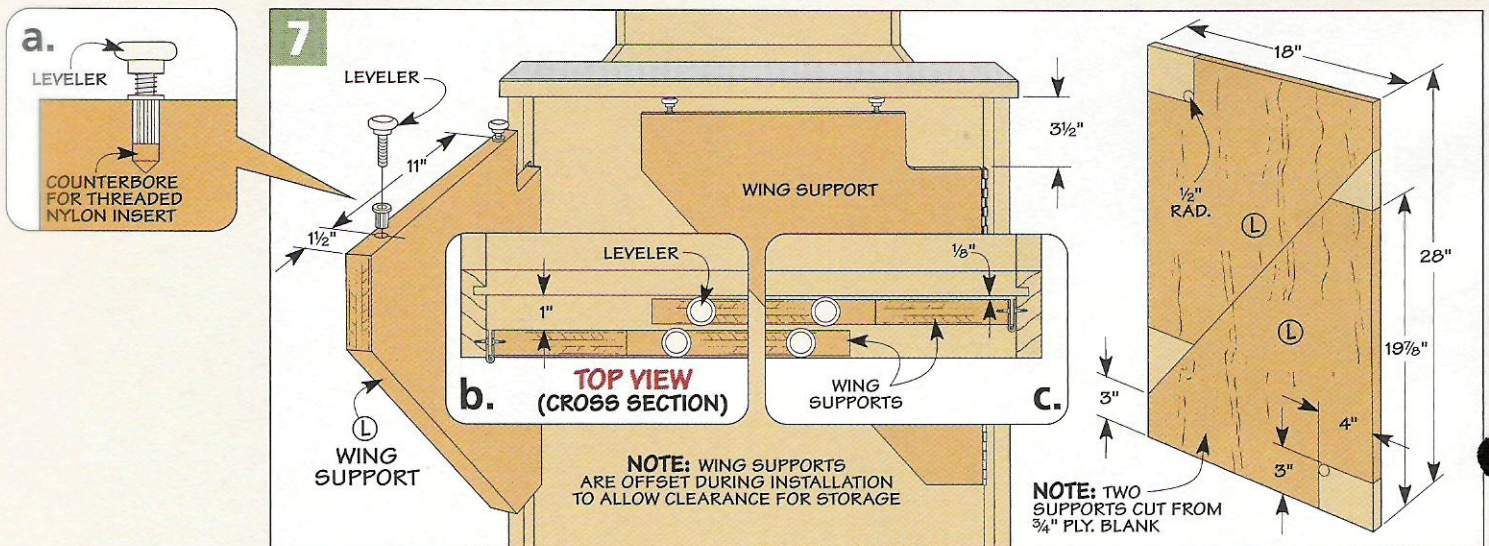

warping of the wing, I cut another piece of laminate to size and glued it to the lower face of the wing, like you see in Figures 8a and 8b.

Install the Wings – All that's left to do on the wings at this point is to install them. To allow the wings to fold down flush with the cabinet and tuck under the top edge of the housing, I used a pair of unique hinges. You can read more about them below. To install the hinges, I started by screwing them in place on the bottom of the table using the dimensions shown in Figure 8a.

At this point, you'll want to be sure to screw the hinges in place using the *slotted* openings in the hinge. This will allow you to adjust them for a perfect fit once the wings are installed on the cabinet.

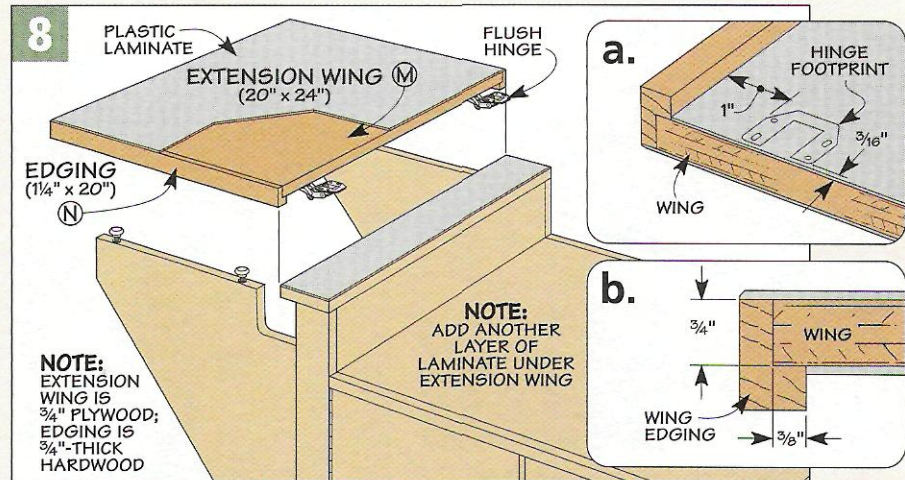

Next, set the wings in place on the supports and level them out with the cabinet. After butting the cabinet and wings together, screw the hinges to the top of the housing (Figure 8).

Here again, use the slotted holes. Once you've checked the clearance and fit by swinging the wings up and down, use the remaining holes to permanently screw the hinges in place.

Using Flush Hinges

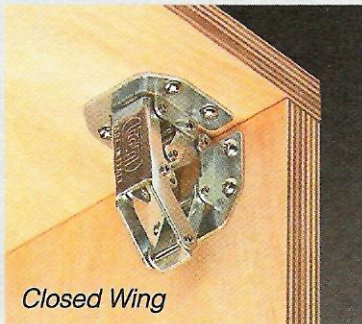

Closed Wing

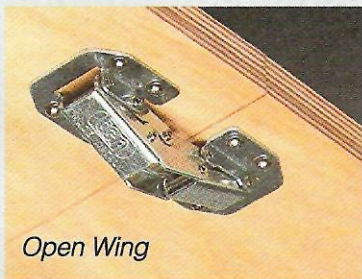

Open Wing

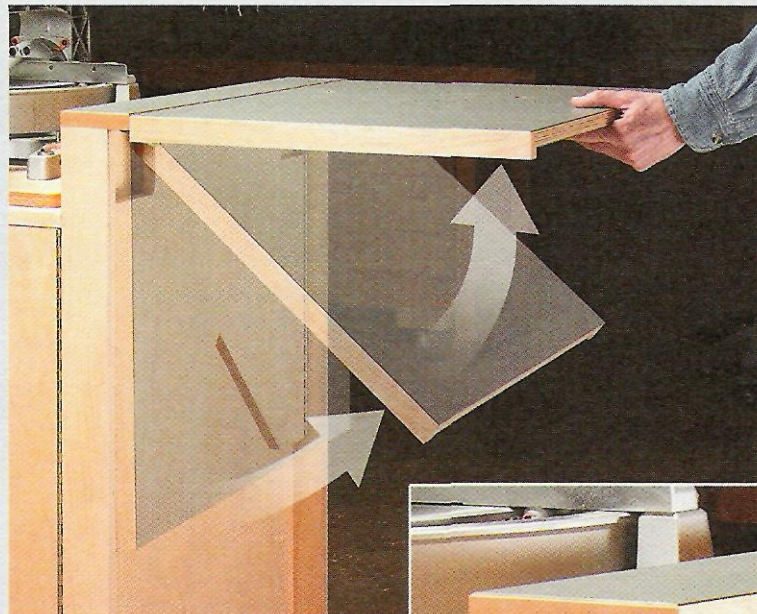

◀ **Flush Hinge.** The action of a flush hinge allows the extension wing to swing up level with the top of the housing. Yet still allows the wing to tuck under the housing for storage (see inset).

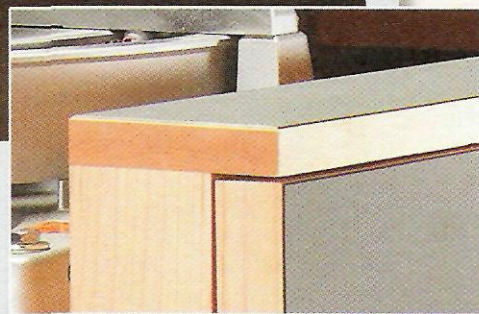

All it takes is a simple hinge to allow the tables to swing up and down. But I decided to use a unique piece of hardware for this project — a flush hinge.

Table Position – What makes a flush hinge different is how it positions the table whether it's in the open or closed position, as in the two example photos above.

Designed for drop leaf tables, these hinges eliminate the large gap and offsets you typically have when the table leaf is in the down position.

Flush hinges allow the leaf, or the extension wing in the case of the tool station, to swing *under* the surface it's mounted to, like you see in the upper right photo. You can see in the inset photo

above that in the stored position you end up with a clean, practically gap-free look.

You can find out where to order flush hinges in Sources on page 35.

Storage

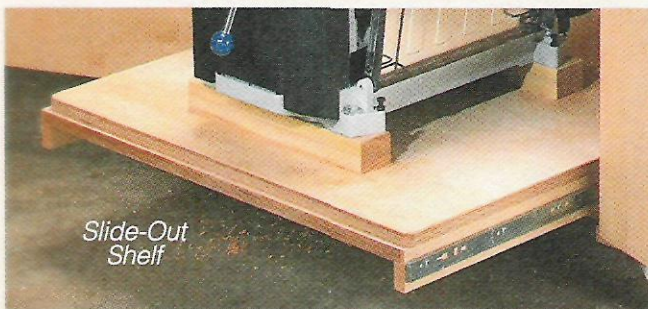
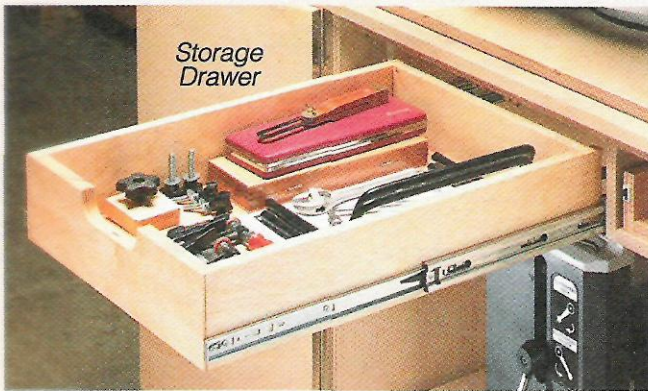

▲ **Easy Access.** A pair of full-extension slides provides easy access to the contents of the storage drawer. Below, a 3/4-extension slide makes it easy to retrieve a stored tool without making the cabinet unstable.

You're on the home stretch at this point. The last couple steps are to add a drawer for storing accessories along with a slide-out shelf for storing the tool you're not using.

Drawer – The storage drawer fits between the fence holders inside the cabinet. As you can see in Figure 9, the drawer itself is rather simple to construct. The front/back (O) and sides (P) are made from 3/4" plywood. And the drawer bottom (Q) is just a piece of 1/4" plywood.

As you size the parts, there are a couple things to keep in mind. For starters, the drawer rides on full-extension, metal slides. The ones I used meant the drawer had to be 1" narrower than the space between the fence holders.

The other thing to account for when sizing the drawer is the locking rabbet joint used to hold the sides to the front and back. You can see this joint in Figure 9b.

With the parts sized and the joinery cut, you can cut the groove for the drawer bottom and then assemble the drawer. Finally, install the metal drawer slides and slip the drawer in place, as in Figure 9a.

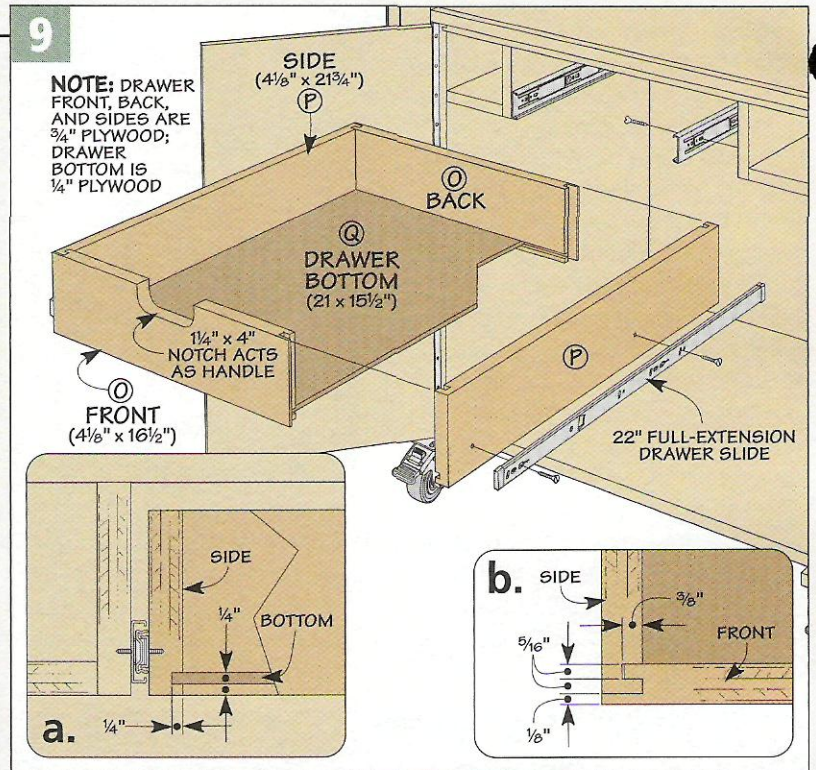

Slide-Out Shelf – Although you could just set the tool you're not using inside the cabinet to store it, I wanted to make it a little easier to get it in and out. So I added a slide-out tool shelf like you see in Figure 10.

The shelf (R) is a piece of 3/4" plywood. To mount the 3/4-extension drawer slides, there are a pair of sides (S) made from 3/4"-thick hardwood, as you can see in Figure 10.

To accept the shelf, the top inside of the cabinet is rabbeted, as illustrated in Figure 10a. And a slot cut in the shelf

makes a convenient handhold for pulling the shelf out.

Tool Base – To prevent the miter saw or planer from sliding around during use, I installed each tool on a base and then used a groove and cleat to lock the base in place.

Each tool base (T) is just a piece of plywood with a groove cut down the center, as in Figure 11. The groove mates with a hardwood cleat (U) installed on the cabinet. Bevels on the top edges of the cleat make it easy to locate the tool base over the cleat

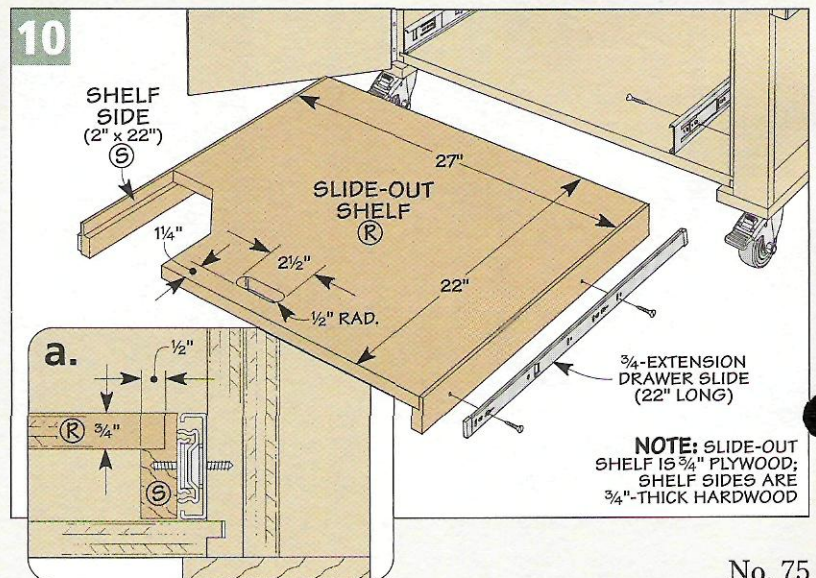

(Figure 11a). Finally, to keep the base from shifting side to side during use, a couple *filler strips* (V) are glued into the groove (Figure 11).

Mount Tools – With each tool base complete, you can mount your miter saw and planer. Depending on your tools, you'll most likely have to raise them so they're level with the top of the housing and wings.

The simplest way to do this is to add a couple spacer strips between the tool base and the tool. You can see how I did this in Figure 11 and the lower photo on the opposite page. Once you have the strips made, you can mount each tool in place.

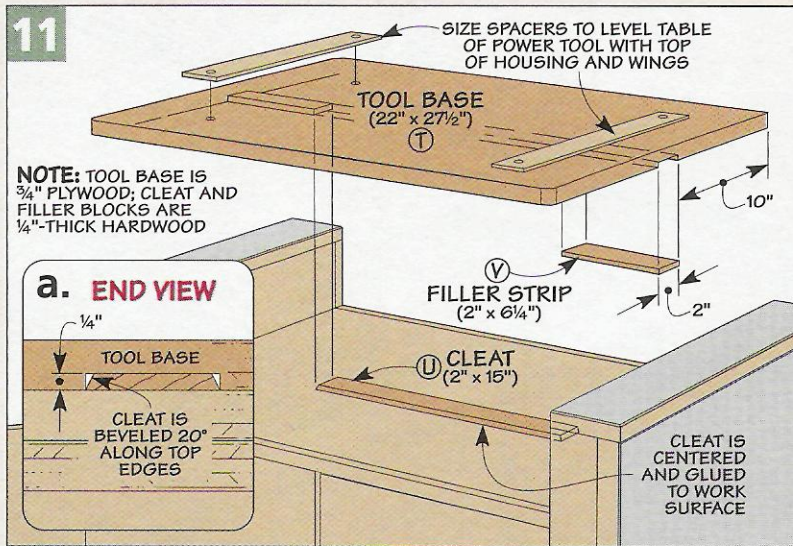

Fences

The fence on a typical miter saw works fine with small workpieces. But if you spend a lot of time cutting anything longer than a couple feet, it's nice to have the support of some auxiliary fences. And a stop block makes it easy to cut a number of workpieces to identical length.

Fences – Each fence is just a *face piece* (W) and *base* (X) reinforced with a couple *support blocks* (Y), as you can see in Figure 12. All the parts are made from 3/4" plywood. To avoid wear and tear on the face of the fence, I added plastic laminate, like you see in the photo at right.

After assembling the fence, cut a groove down the face for a piece of T-track. The T-track accepts a flange bolt so you can position the stop block anywhere along the fence and then lock it securely in place. The T-track is screwed into the support blocks on the fence, as in Figure 12a.

The fences are mounted to the wings with studded knobs and threaded inserts. To locate them on the wings, you'll need to have your miter saw sitting on the cabinet. Then using a straightedge, align each fence with your miter saw.

After clamping the fences to the wings, drill holes through the fence base and into the wings for the inserts. Chamfering the edge of the

hole before screwing the inserts in place minimizes any chance of chipping out the plastic laminate.

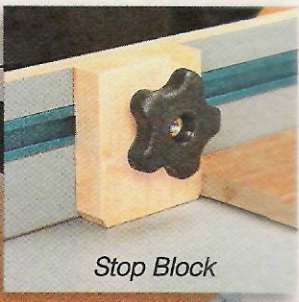
Stop Block – The last part of the fence you need to make should only take a few minutes. It's simply a hardwood *stop block* (Z) with a hole drilled through it (see inset photo at right). The bottom corners are mitered to ensure sawdust doesn't keep the workpiece from making contact and a flange bolt, washer, and knob secure it to the fence. 

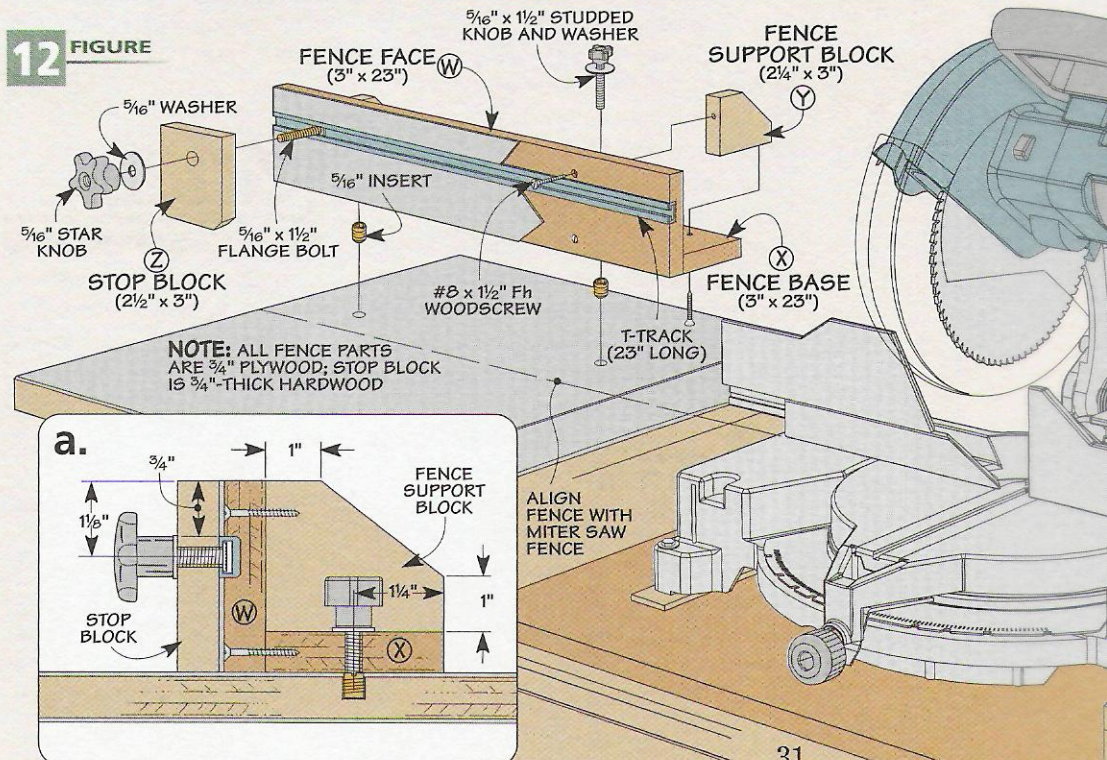
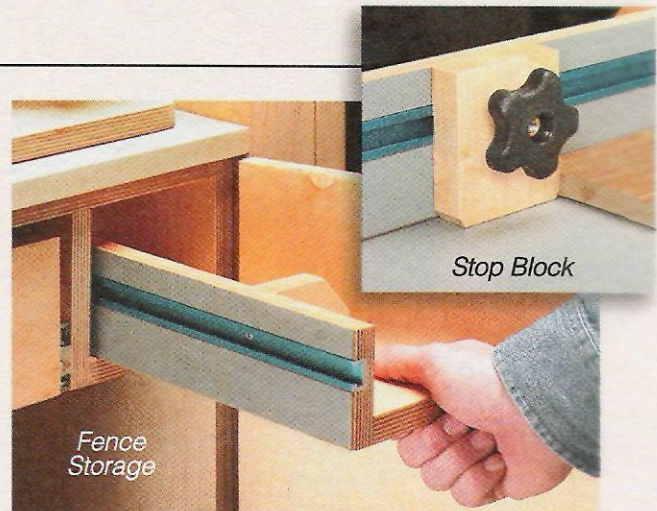



Secret Sources for Shop Supplies

Finding the right supplies and materials for your shop doesn't have to be a hassle. Here's a few of the "secret" sources we use all the time.

I'll admit it. I'm a catalog junkie. When one of my usual woodworking catalogs shows up in the mail, I can't help but sit down and start paging through it, checking to see what's new — and making sure they still have the old stuff.

These are the catalogs you know about. The ones from companies like *Rockler*, *Woodcraft*, *Lee Valley*, and dozens of others. They carry all sorts of things woodworkers need (or just plain would like to have).

But sometimes they don't have just what I'm looking for. That's when I turn to the catalogs and websites of my "secret" supply sources. When there's something you need and you can't get it anywhere, check out the sources below that we use.



SMALL PARTS INC.

Small might be in their name, but it certainly doesn't describe

what *Small Parts, Inc.* has to offer to a woodworker.

Their catalog features almost 500 pages of a wide variety of items. You can find everything from fasteners

and cutting tools, to bearings, clamps, and hand tools.

But one of the main reasons I turn to *Small Parts, Inc.* is their stock of small materials like aluminum, brass, and stainless steel stock in a variety of shapes and sizes. And if you need tubing in aluminum, brass, bronze, or copper, *Small Parts, Inc.* is the place to look.



Another supplier that has huge catalog (500-plus pages) is *Reid Tool Supply Company*. When I can't find a particular piece of hardware through my usual sources, I pull out my *Reid Tool* catalog.

It's easy to lose track of time when you're thumbing through this catalog. I spot so many interesting pieces of hardware that I want to come up with a jig or fixture just to make use of them.

But most of the time, I turn to *Reid* for things like knobs, handles,

casters, and toggle clamps. They have such a wide variety, they're sure to have exactly what you need. Like *Small Parts, Inc.*, they carry materials such as aluminum, brass, and steel stock.

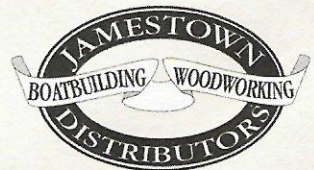

More well-known in the sea-faring world, *Jamestown Distributors* is a great source of supplies for woodworkers who don't go anywhere near the water — but do build projects for the outdoors. For outdoor projects that you want to last a lifetime, it's best to use hardware suited to the task. And that's what *Jamestown Distributors* has.

Jamestown Distributors started out as a stainless steel fastener supplier to boatbuilders. While they still cater to boatbuilders, woodworkers can find the types of products better suited for use outdoors, such as stainless steel and brass fasteners. They

also carry silicon bronze and galvanized items, as well as copper nails.

Outdoor hardware isn't all you'll find. *Jamestown Distributors* also carries adhesives and finishes for your outdoor projects.

KLINGSPOR'S WOODWORKING SHOP
Abrasive — that's the word I'd use to describe *Klingspor's Woodworking Shop*. Of course I don't mean what they're like personally. They're actually very nice and helpful.

What I'm talking about is the type of abrasive related to sanding and finishing. Whether you need something as simple as sandpaper, or something more unique, *Klingspor's* is likely to have a way to take care of it. From sandpaper to sanding discs, and sanding sleeves to sanding belts, *Klingspor's* has the widest range of abrasives available.

As a matter of fact, they even have one of the best deals going in their "Bargain Boxes." Each box contains a collection of industrial sanding products you buy by the pound.

It's a great way to satisfy your sanding needs without spending a lot of money. And who really wants to spend a lot of money on sanding supplies if they don't have to?

Sanding supplies aren't all you'll find. They handle other supplies you might like to take a look at. Since their products create a lot of sawdust, dust collection accessories take up a couple pages of their catalog. And to cover up your well-sanded project, they have a wide selection of finishes.

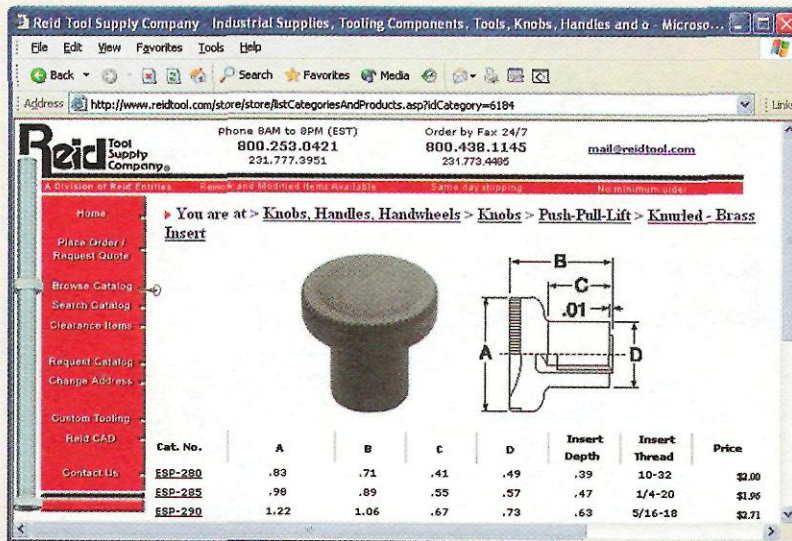

▲ Visit the Web. Our "secret" sources make it quick and easy to order items online. You can find exactly what you need, get specifications on hardware, and then place the order any time of the day or night.



One of the more interesting "secret" sources is *McFeely's*. Although they're well-known for their square-drive screws (in the widest range imaginable), they actually started as a supplier of domestic and exotic hardwoods.

As they grew, they began to offer millwork services and hardware. But over time they chose to concentrate on fasteners, cabinet hardware, and other items — to the benefit of woodworkers all over the country.

So if you're looking for just about any kind of fastener, look no more. *McFeely's* carries screws from #4 x 3/8" up to #14 x 8" for joining land-

scape timbers together. They come in different head styles and thread types, and in materials ranging from standard and stainless steel, to aluminum, brass, and silicon bronze.

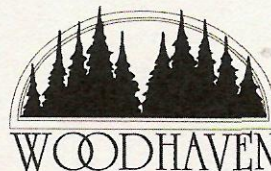

Router heaven — that's the best way to describe what *Woodhaven* has to offer. Whether you're looking for a router table, router bits, or add-on accessories, they're sure to have it.

But *Woodhaven* also carries a wide range of items for building jigs and fixtures. Be sure to check out the five different varieties of T-track they have to offer. Most are available in lengths starting at 12" and going all the way up to 48" long.

You can even custom order all but one type of track up to 96" long. And to make the best use of the tracks, you can order a number of handy accessories such as flip stops, hold-downs, and track connectors.

Check Them Out — When you can't find just what you need in your "usual" woodworking stores or catalogs, it's nice to have these "secret" sources available. They've always been able to meet my needs. 🛠️

HOW TO GET IN TOUCH

- **Small Parts Inc.**
smallparts.com
800-220-4242
- **Reid Tool Supply Company**
reidtool.com
800-253-0421
- **Jamestown Distributors**
jamestowndistributors.com
800-423-0030
- **Klingspor's Woodworking Shop**
woodworkingshop.com
800-228-0000
- **McFeely's**
mcfelys.com
800-443-7937
- **Woodhaven**
woodhaven.com
800-344-6657

Freud Dial-A-Width Dado Blade

With this blade, perfect-fitting dados are just a click away.

I can still remember the first time I used a stack dado blade. I couldn't believe how much better it cut than my old, wobble-type dado. But it wasn't long afterward that I discovered the "downside" of stack dado blades — shims. In order to fine-tune the width of most stack dado blades, you have to insert thin metal (or plastic) shims between the blade and the chippers. And to do this, you have to remove the outer blade from the saw, which can be pretty inconvenient.

But that's not the case with the *Dial-a-Width Dado* by Freud. This stack dado set doesn't require any shims to adjust the width. Instead, it uses an ingenious, adjustable "hub" on the outer blade.

The way it works is actually pretty simple. Threaded into the hub is a flat disc (see inset photo at right). This disc acts as a spacer between



Spacer. A spacer on the inside face of the blade takes the place of shims.

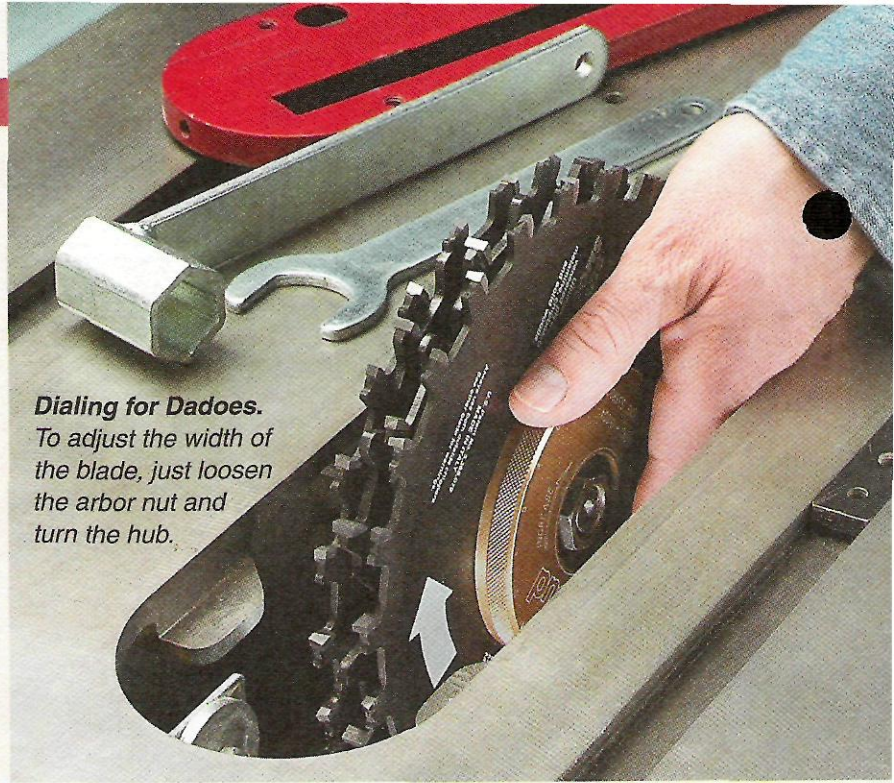
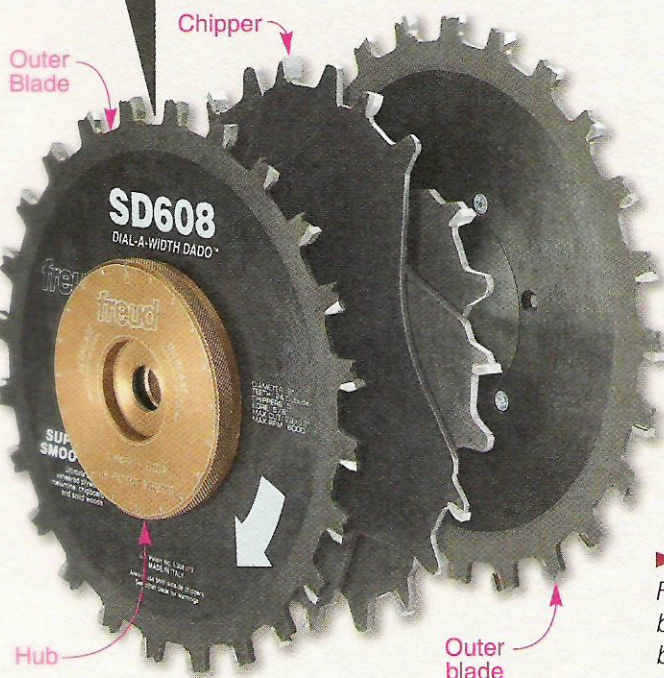

Dialing for Dados. To adjust the width of the blade, just loosen the arbor nut and turn the hub.

the blade and the chipper next to it. Turning the hub causes the disc to move in or out, changing the width of the dado, see photo above.

What all this means is that you can adjust the width of the dado without taking the blade off the saw. All you have to do is back off the arbor nut slightly and turn the hub.

But what's really nice about this blade is that the guesswork has been taken out of making the adjustments. All around the hub are a number of stops. As you turn the hub, you can feel it "click" as it passes each stop. Each click of the hub changes the spacing of the dado by four thousandths of an inch (.004"). Overall, you can change the width of the blade by up to 1/10" simply by turning the hub.

Compatibility – The hub can be attached to either of the two outer blades. To do this, you need to remove a filler plate from the center of the opposite blade and swap it with the hub. This allows you to use the dado set on either right-tilt or

left-tilt table saws. But this same filler plate can create a compatibility issue with some saws. That's because the plate is held in place with three machine screws and lock nuts. The lock nuts stick out so far that they hit the casting holding the arbor of some *Craftsman*, *Ridgid*, and *Grizzly* table saws. (You may be able to get around this problem by using a spacer between the dado blade and the arbor flange of your saw.)

One other thing to be aware of. Because the hub increases the overall thickness of the dado blade by nearly 1/4", you may find that the arbor of your table saw is too short to accommodate the *Dial-a-Width Dado* with all five chippers in place. If this is the case, you'll have to make overlapping cuts for wider dados.

Cost – Of course, the real test for any dado blade is in how well it cuts. And here, the *Freud Dial-a-Width Dado* doesn't disappoint. It produces clean, chip-free cuts in plywood as well as solid wood. But as you might expect, it has a price tag to match. The 8"-dia. *Dial-a-Width Dado* set sells for about \$230. (See margin on opposite page for sources.) That may sound high, but it's really only a little more than other dado sets of comparable quality. And to me, not having to use shims any more is definitely worth the extra cost. 

▶ **Flat is Better.** The Freud *Dial-a-Width Dado* blade cuts smooth, flat-bottomed dados.



Sources

MAIL ORDER SOURCES

Similar project supplies may be ordered from the following companies:

Sharpening Box

■ The only hardware you'll need to build the sharpening supplies box shown on page 6 is a set of four catches. We purchased these locally from a hardware store.

The anti-skid tape used on the lid of the box was also purchased at a hardware store. But if you have trouble finding it locally, you can order it from *Reid Tool*, item JT-35209.

Dual Tool Station

■ Many of the hardware items used on the dual tool station (page 24) are commonly available. This includes the wood screws, piano hinges, bullet catches, door handles, and threaded inserts.

In addition, you'll also need mounting hardware for the tools that you plan to use with the station.

When it comes to finding some of the other hardware items for the tool station, you may have to look a little further than your local hardware store. We turned to *Rockler* for the 5-star knob (#23812), flange bolt (#83311), T-track (#21753), 3" locking swivel casters (#31870), and flush hinges (#28910). However, you can find similar hardware items from many of the sources listed in the margin at right.

The studded knobs used to attach the fences to the extension wings are available from *ShopNotes Project Supplies* (see box

below. You'll need to order four of item #1065207.

Drawer Slides – The $\frac{3}{4}$ -extension drawer slides we used on the slide-out shelf are available from *Rockler* (#39372), as are the full-extension slides used on the drawer (#32516). (Both are 22" long.) You can find similar drawer slides from some of the sources listed in the margin. Just make sure that whatever hardware you choose is rated to handle the weight of the tool you'll be placing on the shelf.

Levelers – The hardware used to level out the extension wings is actually nothing more than a set of four $\frac{7}{8}$ "-dia. adjustable furniture glides. The ones we used came with the threaded nylon inserts and were purchased at a local hardware store. But if you can't find these, you may have to get something similar and use them with threaded brass inserts. 

Plank-Top Workbench

■ Other than some ordinary wood screws, the only other supplies you'll need for the plank-top bench (page 16) are some construction lag screws.

The ones we used are manufactured by *Hillman* and have a bronze ceramic coating and a large, truss head with a star drive.

Hillman screws and fasteners are carried by several major home centers. The manufacturer's item number is 47877.

If you have trouble finding these particular lag screws, ordinary lag bolts and washers will work equally well. (They just won't look as cool.)

Machinist's Vises

■ Machinist's vises like the ones shown on page 22 are available from many tool stores, hardware stores, and home centers.

Auxiliary Jaw Faces – The polyurethane and rubber-lined soft jaw faces

shown at the top of page 23 are both available from *Tool Crib of the North*, as well as other sources. The metal bending jaws shown at the bottom of the page are sold through *Lee Valley*, item 50K08.01.

SHOPNOTES PROJECT SUPPLIES

We now feature hardware from **ROCKLER** in many of our new project kits. To order, please use our toll-free order line, see below. It's open Monday through Friday, from 8 AM to 5 PM Central Time. Before calling, please have your VISA, MasterCard, Discover, or American Express card ready.

If you would prefer to mail in an order, please call the toll-free phone number below for more information concerning shipping charges as well as any applicable sales tax.

1-800-347-5105

ShopNotes *on the web*

- "Online Extras" - Plans, Patterns, & More
- Over 100 Woodworking Tips Online
- Visit Our Woodworking Shop Tours Gallery
- Project Plans You Can Download
- Catalog of Project Kits, Tools, Jigs, & Plans
- Forums for Woodworking, Tools, & Classifieds
- Links to Other Woodworking Sites
- Order *ShopNotes* & *Woodsmith* Back Issues

www.shopnotes.com

Online Customer Service

Click on Subscriber Services at **www.shopnotes.com**

- Access your account status
- Change your mailing or email address
- Pay your bill
- Renew your subscription
- Tell us if you've missed an issue
- Find out if your payment has been received



Scenes from the Shop

Dual Tool Station. Whether you use them with a planer or a miter saw, the fold-out extension wings on this tool station provide plenty of support for long workpieces. Plans begin on page 24.

▼ **No More Shims.** An adjustable hub mechanism on this stack dado blade allows you to fine-tune the width of the blade without shims. Learn more about it on page 34.



Sharpening Supplies Box. The lid of this stacking storage box doubles as a non-slip worksurface when sharpening your hand tools. Complete plans can be found on page 6.

Dual Tool Station

Materials

A Top/Bottom (2)	23 ⁵ / ₈ x 29 ¹ / ₄ - ³ / ₄ Ply.
B Sides (2)	23 ⁵ / ₈ x 28 - ³ / ₄ Ply.
C Back (1)	30 x 28 - ³ / ₄ Ply.
D Fence Holder Sides (2)	4 ³ / ₄ x 23 ¹ / ₄ - ³ / ₄ Ply.
E Fence Holder Btms. (2)	4 ³ / ₄ x 23 ¹ / ₄ - ³ / ₄ Ply.
F Worksurface (1)	23 ¹ / ₄ x 30 - ³ / ₄ Ply.
G Edging (2)	³ / ₄ x ³ / ₄ - 30
H Housing Back (2)	24 x 33 - ³ / ₄ Ply.
I Housing Sides (4)	³ / ₄ x 2 ⁵ / ₈ - 33
J Housing Top/Btm. (4)	³ / ₄ x 3 ¹ / ₈ - 24 ³ / ₄
K Doors (2)	14 ³ / ₁₆ x 27 ¹ / ₈ - ³ / ₄ Ply.
L Wing Supports (4)	18 x 19 ¹ / ₈ - ³ / ₄ Ply.
M Extension Wings (2)	20 x 24 - ³ / ₄ Ply.
N Wing Edging (4)	³ / ₄ x 1 ¹ / ₄ - 20
O Drawer Frt./Back (2)	4 ¹ / ₈ x 16 ¹ / ₂ - ³ / ₄ Ply.
P Drawer Sides (2)	4 ¹ / ₈ x 21 ³ / ₄ - ³ / ₄ Ply.
Q Drawer Bottom (1)	21 x 15 ¹ / ₂ - ¹ / ₄ Ply.
R Slide-Out Shelf (1)	22 x 27 - ³ / ₄ Ply.
S Shelf Sides (2)	³ / ₄ x 2 - 22
T Tool Base (2)	22 x 27 ¹ / ₂ - ³ / ₄ Ply.
U Cleat (1)	¹ / ₄ x 2 - 15
V Filler Strips (4)	¹ / ₄ x 2 - 6 ¹ / ₄
W Fence Face (2)	3 x 23 - ³ / ₄ Ply.
X Fence Base (2)	3 x 23 - ³ / ₄ Ply.
Y Fence Spt. Blocks (4)	2 ¹ / ₂ x 3 - ³ / ₄ Ply.
Z Stop Block (1)	³ / ₄ x 2 ¹ / ₂ - 3

Also Needed: Approximately 16 square feet of plastic laminate for the tops and bottoms of the extension tables, and the tops of the housings.

24" x 24" - ¹/₄" PLYWOOD

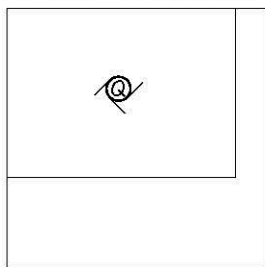

³/₄" x 5¹/₂" - 96" HARDWOOD

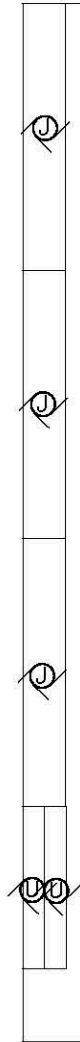

³/₄" x 5¹/₂" - 96" HARDWOOD



³/₄" x 5¹/₂" - 96" HARDWOOD

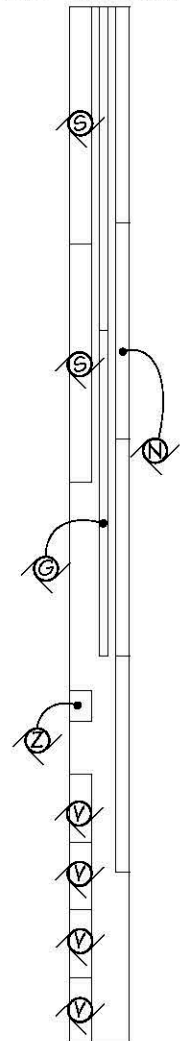

48" x 96" - 3/4" PLYWOOD

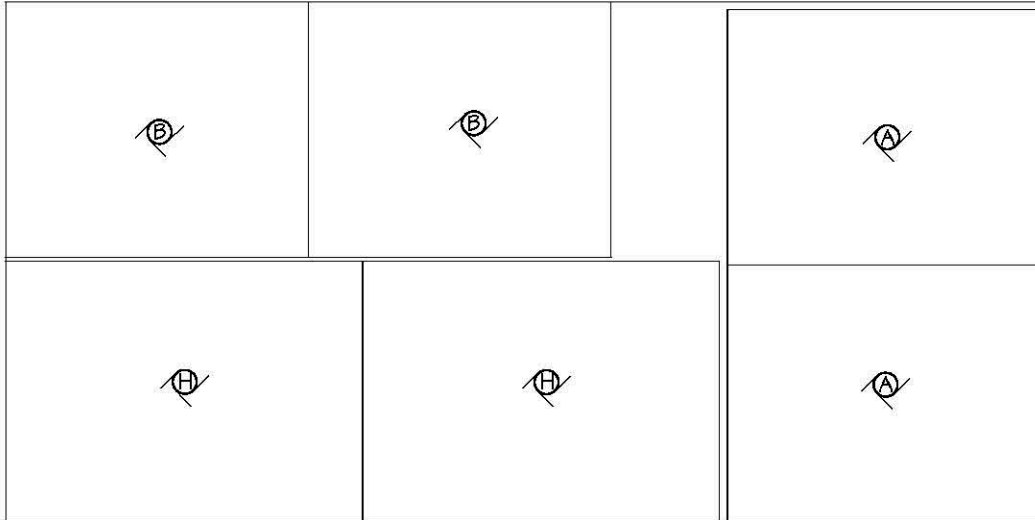

48" x 96" - 3/4" PLYWOOD

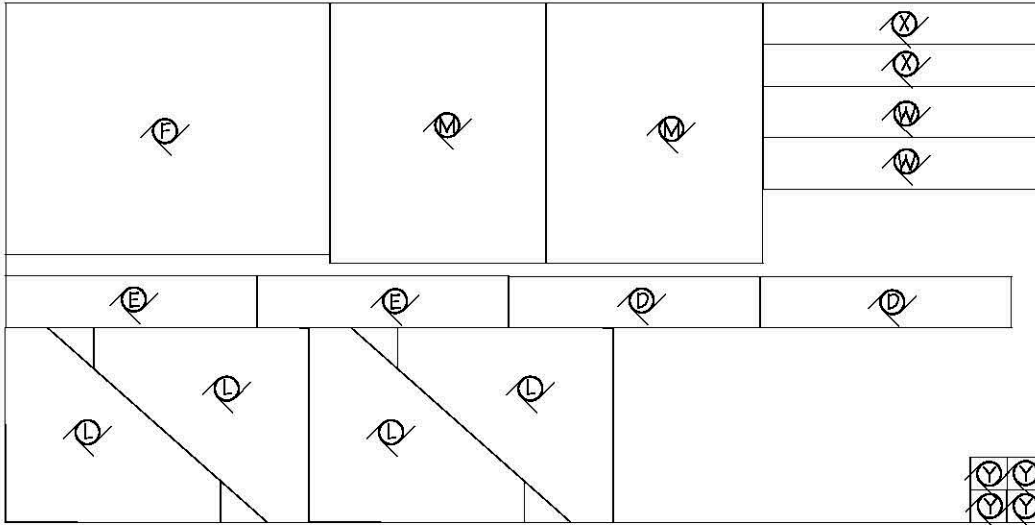

48" x 96" - 3/4" PLYWOOD

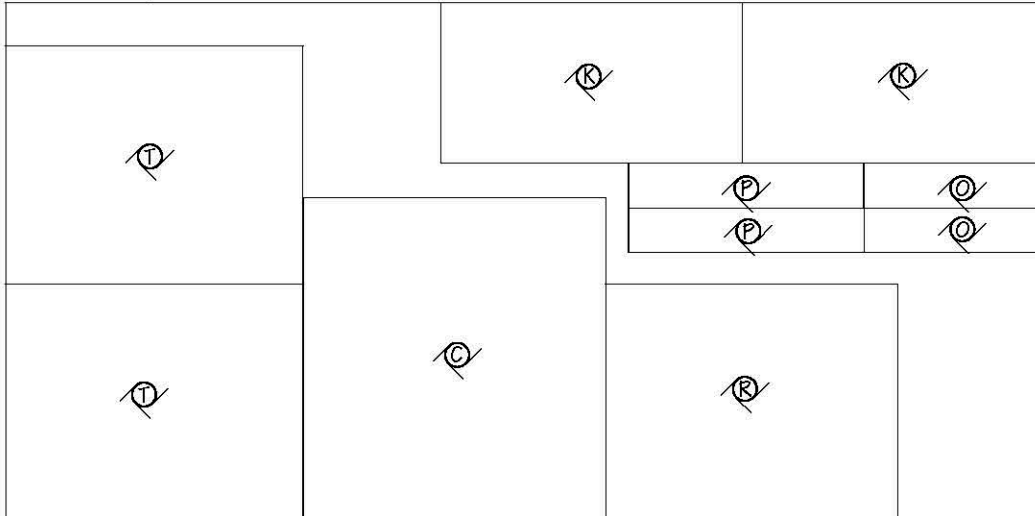

Making a Longer Plank-top Workbench

The Plank-Top Workbench in issue No. 75 will work fine in most workshops. If you need something smaller, all you have to do is shorten up the stretchers and cleats.

A Longer Workbench – But if you'd like a longer workbench, you'll want to consider adding some additional support for the top, like you see in the drawing below for a 12'-long plank-top workbench.

The additional support is provided by adding a center assembly. The nice thing is this center assembly is identical to the end assemblies. So you don't have to worry about any different parts or measurements.

Work on the Stretchers – Once you have the end and center assemblies complete, you can work on the longer stretchers. What's different here is that to fit the center assembly in place, you'll need to cut a centered half lap on the inside face of each of the stretchers (see drawing below). After completing the half laps, you can assemble the workbench.

Add the Cross Rails – The next step is to add the cross rails that support the top. How many you need to add depends on the overall length of the workbench. But it's best to add enough cross rails between the end and center assemblies so the rails

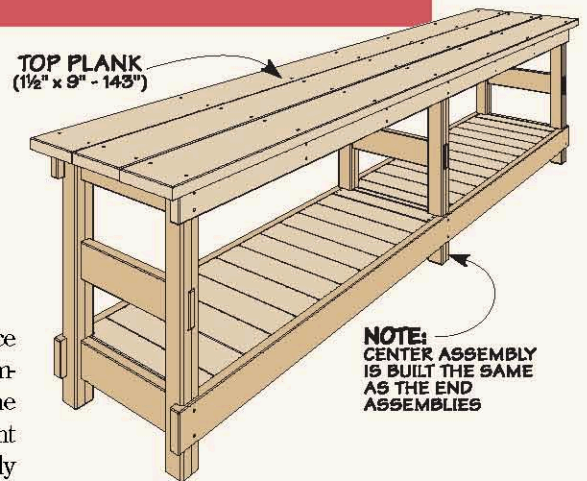

NOTE:
CENTER ASSEMBLY
IS BUILT THE SAME
AS THE END
ASSEMBLIES

are spaced evenly and they're no more than 22" apart.

Cleats and Slats – All that's left to do is add the cleats and slats. After sizing the cleats to fit between the end and center assemblies, you can add the slats. For the even number of slats shown between the end and center assemblies, it's best to work out from the center of the opening and cut the end slats to fit.

