

**MOBILE
TOOL BASES** p. 22

Special Shop Storage Issue

ShopNotes®

Vol. 13

www.ShopNotes.com

Issue 77

SLIDING-DOOR SHOP CABINET

Plus Optional
Hardware
Storage p. 6

Table Saw:
Top Tune-Up Techniques p. 12

Router Bits:
Solve Your Storage Problems p. 30

Tool Stand:
All New Space-Saving Design p. 18



ShopNotes®

Issue 77

Sept./October 2004

PUBLISHER Donald B. Peschke

EDITOR Terry J. Strohman

SENIOR EDITORS Bryan Nelson
Vincent Ancona

ASSOCIATE EDITOR Phil Huber

ASSISTANT EDITOR Ron Johnson

ART DIRECTOR Cary Christensen

SR. GRAPHIC DESIGNER Jamie Downing

SENIOR ILLUSTRATOR Roger Reiland

ILLUSTRATORS David Kallemyn

Peter J. Larson

ELEC. IMAGE SPECIALIST Allan Ruhnke

CREATIVE RESOURCES: *Creative Director:* Ted Kralicek • *Sr. Project Designers:* Ken Munkel, Kent Welsh, Ryan Mimick, Chris Fitch • *Shop Craftsmen:* Steve Curtis, Steve Johnson • *Sr. Photographer:* Crayola England • *Photo Intern:* Julia Adkisson

SPECIAL PUBLICATIONS: *Corp. V.P.:* Douglas L. Hicks • *Art Dir.:* Douglas A. Flint • *Sr. Graphic Designer:* Chris Glowacki • *Graphic Designer:* Lindsay Rees • *Videographer:* Mark Hayes, Jr. • *Sr. Editor:* Craig Ruegsegger • *Assoc. Editor:* Joel A. Hess

CIRCULATION: *Circ. Oper. Director:* Sandy Baum • *Circ. Marketing Dir.:* Wayne J. Klingbeil • *Strategic Business Analysts:* Kris Schlemmer, Paula M. DeMatteis • *Circ. Marketing Analyst:* Patrick Walsh • *Renewal Mgr.:* Paige Rogers • *Circ. Marketing Assoc.:* Christine Forret • *Circ. Fulfillment Mgr.:* Stephanie Forinash • *Sr. Graphic Designers:* Robin Friend, Randy Shebek

CORPORATE SERVICES: *V.P. of Finance:* Mary R. Scheve • *Controller:* Craig Stille • *Dir. Financial Analysis:* Lesia Smith • *Sr. Acct.:* Laura J. Thomas • *Accts. Payable:* Mary J. Schultz • *Accts. Receivable:* Margo Petrus • *Prod. Dir.:* George Chmielarz • *IT Manager:* Brian VanHeuverswyn • *Electronic Pub. Dir.:* Douglas M. Lidster • *Sys. Admin.:* Cris Schwanebeck • *P.C. Maint. Tech.:* Robert D. Cook • *Assoc. Style Dir.:* Rebecca Cunningham • *New Media Mgr.:* Gordon C. Gaippe • *Multimedia Art Dir.:* Eugene Pedersen • *Web Server Admin.:* Carol Schoeppler • *Web Content Mgr.:* David Briggs • *Multi-media Designer:* Kara Blessing • *Web Prod.:* Terry Walker • *Web Pub. Asst.:* Justin Gruca • *Research Coord.:* Nicholas A. Jaeger • *Prof. Dev. Dir.:* Michal Sigel • *Benefits Specialist:* Jennifer Westover • *Hiring Specialist:* Jessica Tesar • *Facilities Mgr.:* Kurt Johnson • *Office Manager:* Jeanne Johnson • *Admin. Asst.:* Brandi Hammond • *Mail Room Clerk:* Lou Webber

ShopNotes® (ISSN 1062-9696) is published bimonthly (Jan., March, May, July, Sept., Nov.) by August Home Publishing, 2200 Grand, Des Moines, IA 50312.

ShopNotes® is a registered trademark of August Home Publishing ©Copyright 2004 by August Home Publishing. All rights reserved. Subscriptions: Single copy: \$4.95. One year subscription (6 issues), \$27.95. Canada/International add \$10 per year, U.S. funds.

Canadian Subscriptions: Canada Post Agreement Number 40038201. Send change of address information and blocks of undeliverable copies to PO Box 881, Station Main, Markham, ON L3P 8M6.

Periodicals Postage Paid at Des Moines, IA and at additional mailing offices.

Postmaster: Send change of address to ShopNotes, P.O. Box 37103, Boone, IA 50037-2103.

Online Customer Service. www.ShopNotes.com

- Access your account
- Check a subscription payment
- Tell us if you've missed an issue
- Change your mailing or email address
- Renew your Subscription
- Pay your bill

Email: shopnotes@shopnotes.com

Write to ShopNotes, P.O. Box 842, Des Moines, IA 50304 or call 1-800-333-5075, 8:00 am to 5:00 pm, Central Time, weekdays. Or send an email to: orders@shopnotes.com

AUGUST HOME
PUBLISHING COMPANY

Printed in U.S.A.

EDITOR'S NOTE

Cutoffs

A while back, Vince Ancona talked to me about an idea he had. He wanted to do an article on the best way to get materials home from the lumberyard or home center. Specifically, how to safely and securely tie down a load of lumber.

Now someone once told me that "if you can't tie a good knot — tie a lot of them." Unfortunately, that saying pretty much sums up my knot-tying skills. So naturally, I was eager to learn more.

As it turned out, we didn't have to look far to find some qualified advice. Jamie Downing, our senior graphic designer, has been an avid sailor for years. So he really knows his way around a piece of rope.

Our other knot-tying expert, Adolph Peschke, wrote the book on knots — literally. Adolph wrote the Boy Scout Handbook on Pioneering, which covers knots, lashings, and different ways to use them to build structures. If the name sounds a bit familiar, there's a good reason —

Adolph is the father of Don Peschke, founder and publisher of *ShopNotes*.

With all this knowledge at our fingertips, you'd think that coming up with an article on knot-tying would be a piece of cake. But it quickly became obvious that we had more information on knots than we had space for in the issue. So we narrowed the field down to three basic knots that would handle most of your tie-down needs.

A short time ago, that would have been the end of the story. But now, we have the advantage of being able to give you even more information online. Visit our website and you'll not only find videos on how to tie the three knots from this issue, but you'll also learn how to tie an extra knot that isn't shown in the article.

New Face — Allan Ruhnke has joined us as an electronic image specialist. That's really just a fancy way of saying he's responsible for making all the photographs in the magazine look their absolute best.

Terry

Be included, as a part of the Woodworking Shop Tours

On the Web

Visit other *ShopNotes* subscribers' workshops and see photos of the shop projects they've built. It's all online at Woodworking Shop Tours on the *ShopNotes* web site:

www.ShopNotes.com

We want you to be part of our shop tours! To submit photos of your favorite *ShopNotes* projects or views of your shop, just follow the instructions you'll find on our web site.



Contents

Features

Sliding-Door Shop Cabinet _____ 6

You'll be amazed at all the tools and supplies you can store inside (and outside) this slim cabinet.

Table Saw Tune-Up _____ 12

Now's a good time to take a look "under the hood" and get your table saw in top shape. Our step-by-step process will have it running at peak performance in no time.

Hi-Tech Tune-Up Tools _____ 17

Want to add a new dimension to your table saw tune-up? We take a look at a few hi-tech products to handle the task.

Fold-Away Tool Stand _____ 18

Now you see it, now you don't. Build a rock-solid tool stand that folds out of the way in seconds.

Making Tools Move _____ 22

Mounting your power tools on mobile bases can be a great solution for small shops. We'll tell you what to look for and give you the rundown on a number of popular models.

Under-Stair Storage _____ 26

Make the most of the space beneath your stairs with this easy-to-build, adjustable storage system.

Router Bit Rack _____ 30

Organize your router bits and accessories in an afternoon with this simple wall rack.

Departments

Readers' Tips _____ 4

Shop-tested tips to solve common woodworking problems.

Shop Talk _____ 32

These three simple knots will get your next lumber purchase home safely, without a lot of fuss.

Tool Chest _____ 34

Tired of pegboard hooks that won't stay put? Learn more about hooks that keep tools in their place.

Sources _____ 35

Mail-order sources and supplies to help you complete the projects featured in this issue.

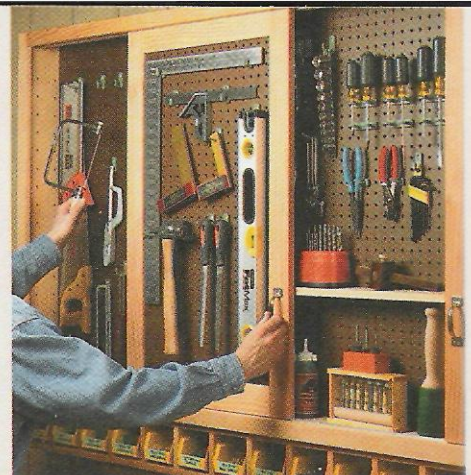

Shop Cabinet

page 6

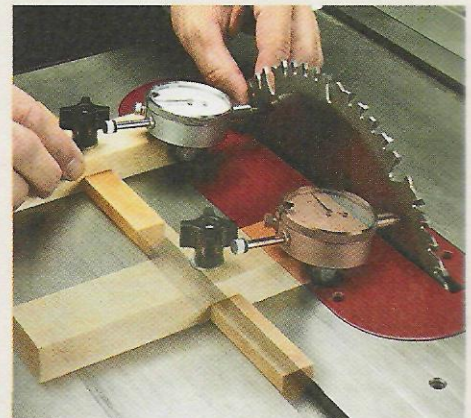

Table Saw Tune-Up

page 12



Under-Stair Storage

page 26

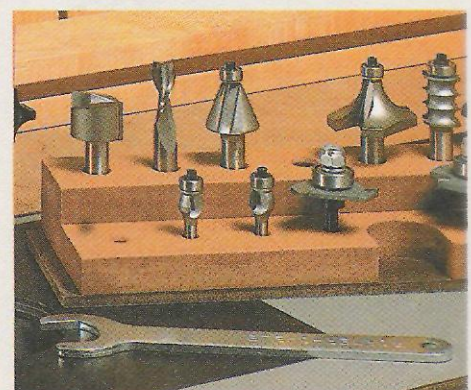

Router Bit Rack

page 30

Readers' Tips

Beam Compass

■ I needed to lay out some large circles for a project recently. And knowing how important accuracy is when making large circles, I built a beam compass to meet my needs. This compass is simple, easy to use, and changing circle size is as easy as simply sliding the dowel.

The arm is made from a four foot length of $\frac{5}{8}$ "-dia. dowel rod with a slot and $\frac{1}{4}$ " hole drilled in one end to hold a pencil. The pencil is clamped

in place by drilling a second $\frac{1}{4}$ " hole perpendicular to the first to fit a bolt and wing nut (illustration below).

The compass is adjusted by a 4"-long piece of $\frac{1}{2}$ "-dia PVC pipe drilled and tapped to accept a $\frac{5}{16}$ "-dia. nylon bolt. The bolt holds the dowel at the desired length.

A 3d nail inserted in a pre-drilled hole in the bottom of the PVC acts as

the pivot for the compass as shown in the drawing and photo below. The bottom of the dowel is sanded flat to accommodate the nail head and prevent dowel rotation.

Now, just slide the dowel in place and adjust it to the radius you want and you're ready to lay out a circle.

Jeff Streba

Salt Lake City, Utah

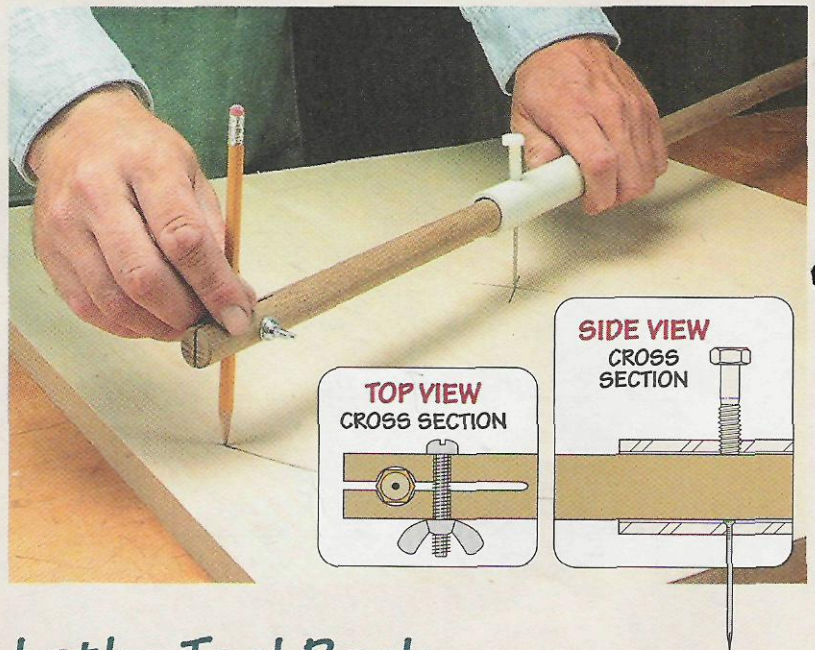

Lathe Tool Rack

■ To keep my turning tools close at hand, I built a simple tool rack to attach to my lathe. Now my lathe tools are in easy reach and I don't have to go hunting all over my shop whenever I want to use them.

Another feature I like is that the ends of the tools stick out the back and are readily visible. This makes it easy to identify the turning tool I need when changing tools.

The rack is simply made out of a piece of 2" x 2" stock cut to length (depending on the number of tools you have). I then glued a wider piece

of $\frac{1}{4}$ " plywood to the rack. This let me clamp the rack to the lathe leg as shown in the illustration on the left.

Five $\frac{1}{8}$ "-dia. holes were drilled for my turning tools. But you may want to vary the size and number of holes to fit your specific tools.

The holes are drilled at an angle of 30° so the tools won't vibrate out of the holes when the lathe runs.

The tool rack can be bolted to the leg or clamped in place if you want to move it around.

Gordon Hildebrant

North Java, New York

ShopNotes No. 77

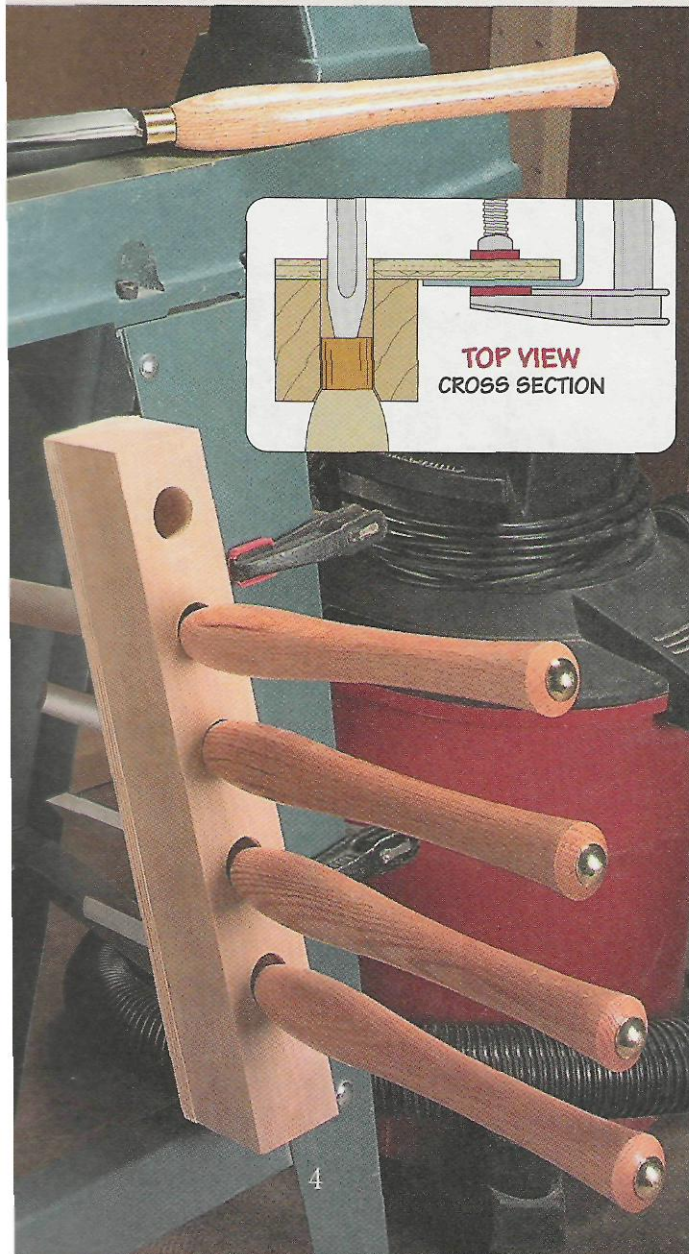

Quick Tips



Kevin Coulson of Emporia, KS reminds us that oily steel wool can be a fire hazard and recommends storing it safely in resealable bags to prevent oxidation.

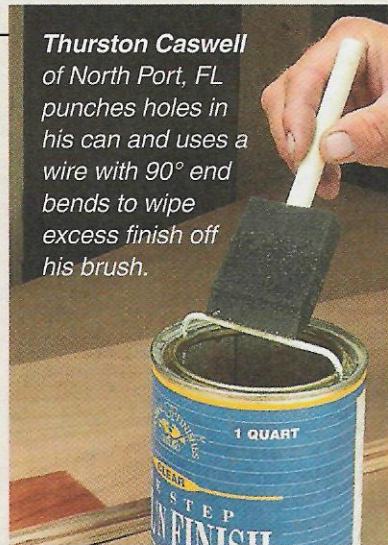

Thurston Caswell of North Port, FL punches holes in his can and uses a wire with 90° end bends to wipe excess finish off his brush.

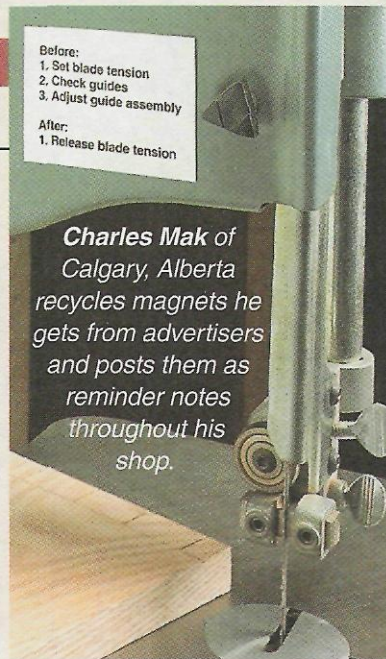

Before:
1. Set blade tension
2. Check guides
3. Adjust guide assembly

After:
1. Release blade tension

Charles Mak of Calgary, Alberta recycles magnets he gets from advertisers and posts them as reminder notes throughout his shop.

Free Tips ON THE WEB

Get more wood-working tips **free**.

Visit us on the Web at **ShopNotes.com**

Sign up to receive a free shop tip by email every week.

Drill Press Storage Rack

Whenever I used my drill press, I spent a lot of time hunting for the items I needed. So I built a display-type storage rack to keep everything organized.

The rack is made from a piece of plywood about 18" long. The top and bottom are beveled at 45°. Legs are attached to the back so it will sit flat on a table or shelf and give the display stability. I then drilled holes and added dowels to hold various sanding attachments, chuck keys, and other drill press accessories.

*Edward Reis
Phoenix, Arizona*

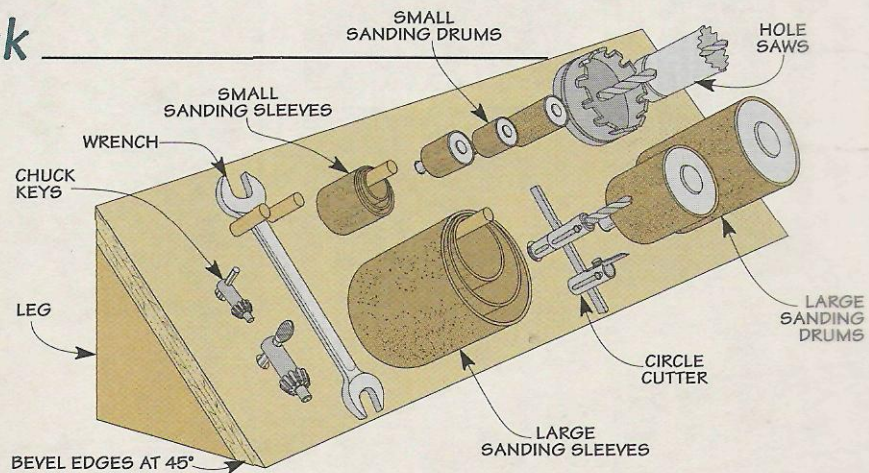

Clip-On Lamp Holder

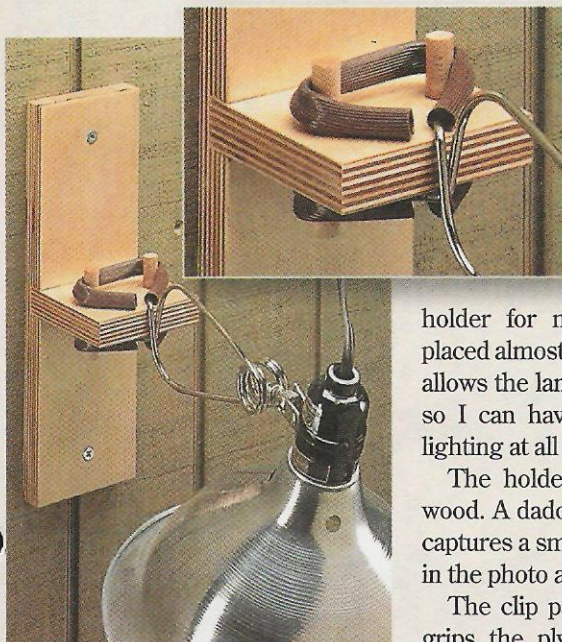

I like the extra light that a clip-on lamp gives when I work. The problem is there's never any place to attach one of these lamps.

To solve this problem, I devised a holder for my shop that can be placed almost anywhere. This holder allows the lamp clip to grip securely so I can have constant and stable lighting at all times.

The holder is made of 3/4" plywood. A dado in the mounting plate captures a small shelf as you can see in the photo at left.

The clip part of the lamp tightly grips the plywood shelf. Through

dowels in the shelf fit inside the clip bends to prevent the lamp from sliding off the holder when the light position is adjusted.

*Guy Gerrard
Orlando, Florida*

Send in Your Tips

To share your original tips and solutions to problems you've faced, send them to: *ShopNotes*, Attn.: Readers' Tips, 2200 Grand Ave., Des Moines, IA 50312. (Or if it's easier, FAX them to us at 515-282-6741.)

We'll pay up to \$200 depending on the published length. Please include a daytime phone number so we can call you if we have any questions.



Sliding-Door Shop Cabinet

Sliding doors and a flexible design allow you to pack a lot of tools into little space.

EXPLODED VIEW
OVERALL DIMENSIONS:
80³/₄"W x 6¹/₄"D x 45³/₈"H

ShopNotes To download
a free cutting
diagram for
the Storage Cabinet, go to:
www.ShopNotes.com

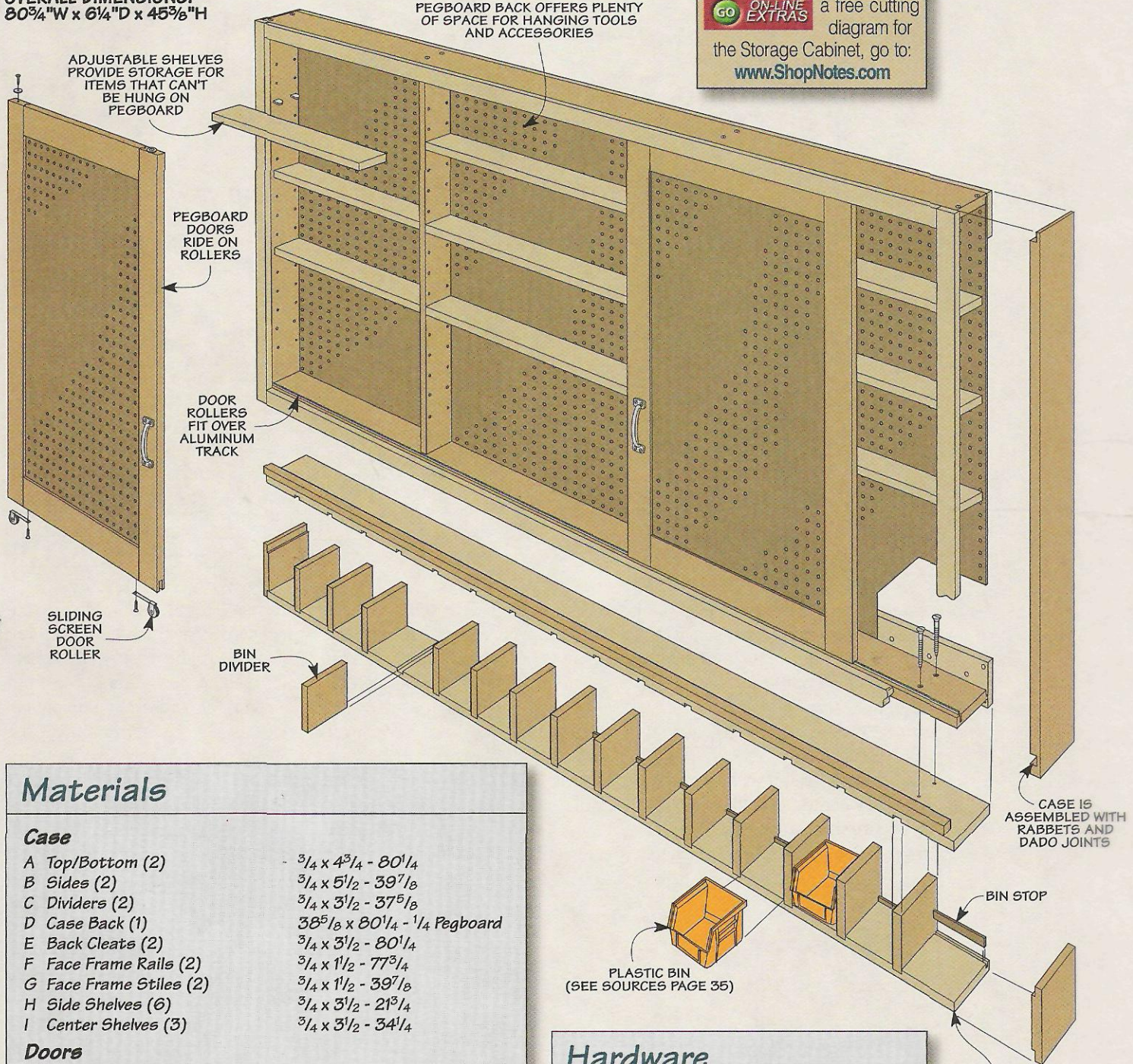

Materials

Case

- | | |
|-------------------------|------------------------------------------------------------------------------------------|
| A Top/Bottom (2) | $\frac{3}{4}$ x $4\frac{3}{4}$ - 80 ¹ / ₄ |
| B Sides (2) | $\frac{3}{4}$ x $5\frac{1}{2}$ - 39 ⁷ / ₈ |
| C Dividers (2) | $\frac{3}{4}$ x $3\frac{1}{2}$ - 37 ⁵ / ₈ |
| D Case Back (1) | 38 ⁵ / ₈ x 80 ¹ / ₄ - $\frac{1}{4}$ Pegboard |
| E Back Cleats (2) | $\frac{3}{4}$ x $3\frac{1}{2}$ - 80 ¹ / ₄ |
| F Face Frame Rails (2) | $\frac{3}{4}$ x $1\frac{1}{2}$ - 77 ³ / ₄ |
| G Face Frame Stiles (2) | $\frac{3}{4}$ x $1\frac{1}{2}$ - 39 ⁷ / ₈ |
| H Side Shelves (6) | $\frac{3}{4}$ x $3\frac{1}{2}$ - 21 ³ / ₄ |
| I Center Shelves (3) | $\frac{3}{4}$ x $3\frac{1}{2}$ - 34 ¹ / ₄ |

Doors

- | | |
|------------------------|----------------------------------------------------------------|
| J Door Stiles (4) | $\frac{3}{4}$ x $2\frac{1}{2}$ - 37 |
| K Door Rails (4) | $\frac{3}{4}$ x $2\frac{3}{4}$ - 18 |
| L Door Panels (2) | 18 x 32 - $\frac{1}{4}$ Pegboard |
| M Side Door Stops (2) | $\frac{3}{4}$ x $\frac{3}{4}$ - 21 ³ / ₄ |
| N Center Door Stop (1) | $\frac{3}{4}$ x $\frac{3}{4}$ - 34 ¹ / ₄ |

Bin Rack

- | | |
|------------------|-----------------------------------------------------------------|
| O Top/Bottom (2) | $\frac{3}{4}$ x $5\frac{1}{2}$ - 79 ³ / ₄ |
| P Ends (2) | $\frac{3}{4}$ x $5\frac{1}{2}$ - 5 ¹ / ₂ |
| Q Dividers (15) | $\frac{3}{4}$ x $5\frac{1}{2}$ - 4 ¹ / ₂ |
| R Stops (16) | $\frac{1}{2}$ x $4\frac{1}{4}$ - $\frac{1}{4}$ Pegboard |
| S Spacer (1) | $\frac{3}{4}$ x 1 - 79 ¹ / ₄ |

Hardware

- (46) #8 x 1¹/₂" Fh Woodscrews
- (16) #8 x 5¹/₈" Fh Woodscrews
- (4) Sliding Screen Door Rollers w/screws
- (1) 1¹/₈" x 3¹/₄" Aluminum Bar (79¹/₄" long)
- (2) 4" Drawer Pulls w/screws
- (36) Shelf Pins
- (4) #8 x 1" Rh Woodscrews
- (4) 1"-dia. Fender Washers
- (10) #8 x 2" Fh Woodscrews
- (16) 4¹/₈" x 5³/₈" Plastic Storage Bins

Case

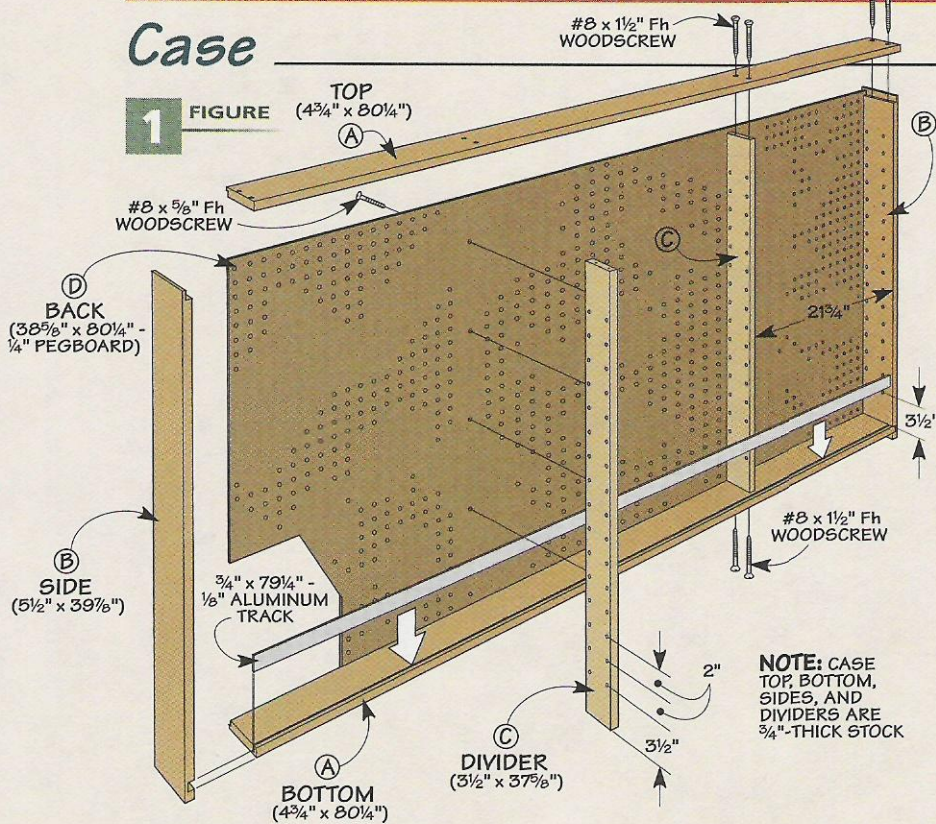

NOTE: CASE TOP, BOTTOM, SIDES, AND DIVIDERS ARE 3/4"-THICK STOCK

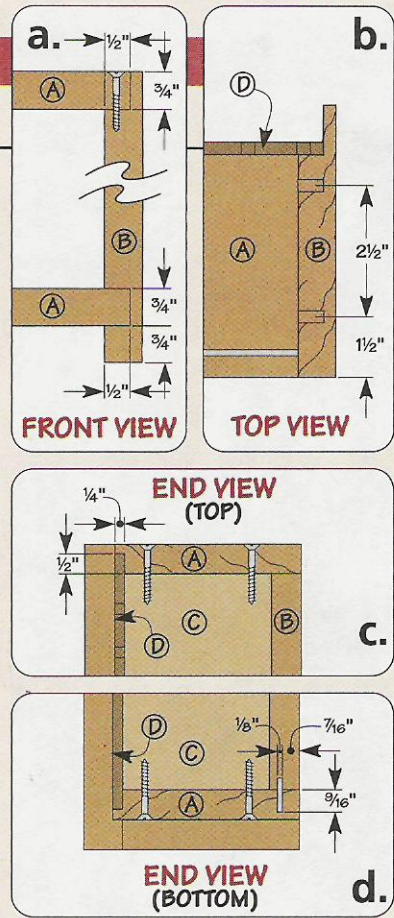

One of the objections to pegboard that I hear over and over again is that it doesn't hold very many tools for the amount of wall space that it takes up. But this pegboard storage project is different. Instead of just a flat pegboard panel mounted to the wall, this project is a shallow cabinet. The back of the cabinet is made with pegboard for hanging tools. But in front of this are shelves and a couple

of sliding pegboard doors. So you end up with nearly double the amount of storage area without taking up any additional wall space.

Case - To build the cabinet, I started with the case. The main parts of the case — the top, bottom, and sides — are all cut from 1x6's. If you take a look at Figure 1b, you'll notice that the sides are wider than the top and bottom of

the case. This has to do with how the pegboard back and cleats are attached to the case. (I'll explain more about that later.) For now, just cut the pieces to the dimensions shown. Then you can cut the rabbets and dados in the sides that will hold the top and bottom of the case (Figures 1 and 1a).

The pegboard panel that will serve as the back of the case fits into a rabbeted opening. But in order to create some clearance behind the pegboard for the pegboard hooks, the back is set in about 3/4" from the wall. To do this, you'll need to make the rabbets on the sides of the case wider than the rabbets on the case top and bottom. Take a look at Figures 1b, 1c, and 1d to see what I'm talking about.

Before you can assemble the case, there are a few details to take care of. First, I drilled some holes on the inside face of the case sides for some shelf pins. Then I cut a kerf near the front edge of the case bottom for a piece of aluminum that will be added later (Figure 1d). This will serve as the "track" for the sliding door.

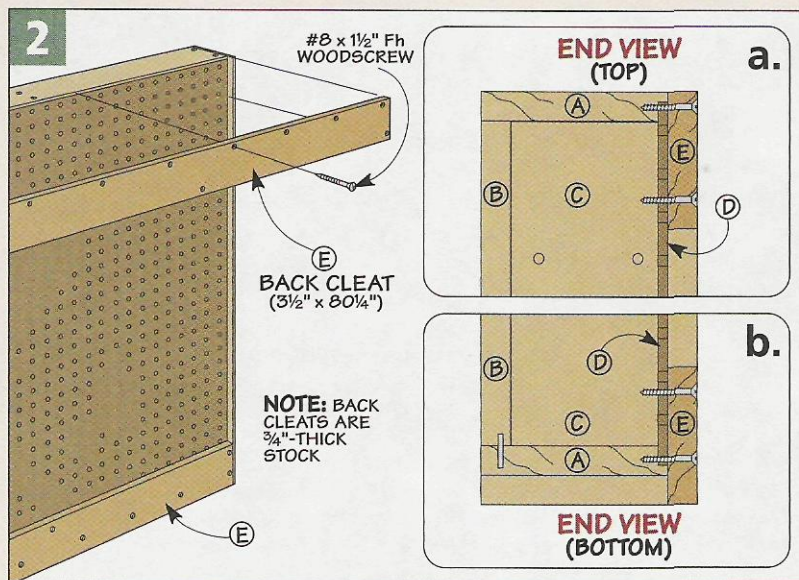

Finally, I drilled some counter-sunk screw holes in the case top and bottom for the screws that will be used to attach the sides and dividers of the case. It's easier to drill these holes on a drill press now, before assembling the case.

Assembly – The case is assembled with glue and some screws. Just make sure to keep the front edges of the top, bottom, and sides of the case flush as you clamp everything together.

Dividers – With the outer frame of the case complete, you can now add a couple of dividers. These are ripped to width and then cut to fit between the top and bottom of the case. But before they're glued and screwed into place, a double row of shelf pin holes is drilled in each divider, just as you see in Figure 1.

Back & Cleats – The back is just a piece of 1/4" pegboard, cut to fit in the rabbeted opening in the back of the frame. It gets held in place with a few screws. Then a pair of cleats are screwed to the back of the case over the pegboard — one at the top and one at the bottom. These help strengthen the cabinet as well as provide support when screwing it to the wall.

With the back in place, I cut a strip of aluminum to fit in the kerf in the bottom of the case. My aluminum

3 FIGURE

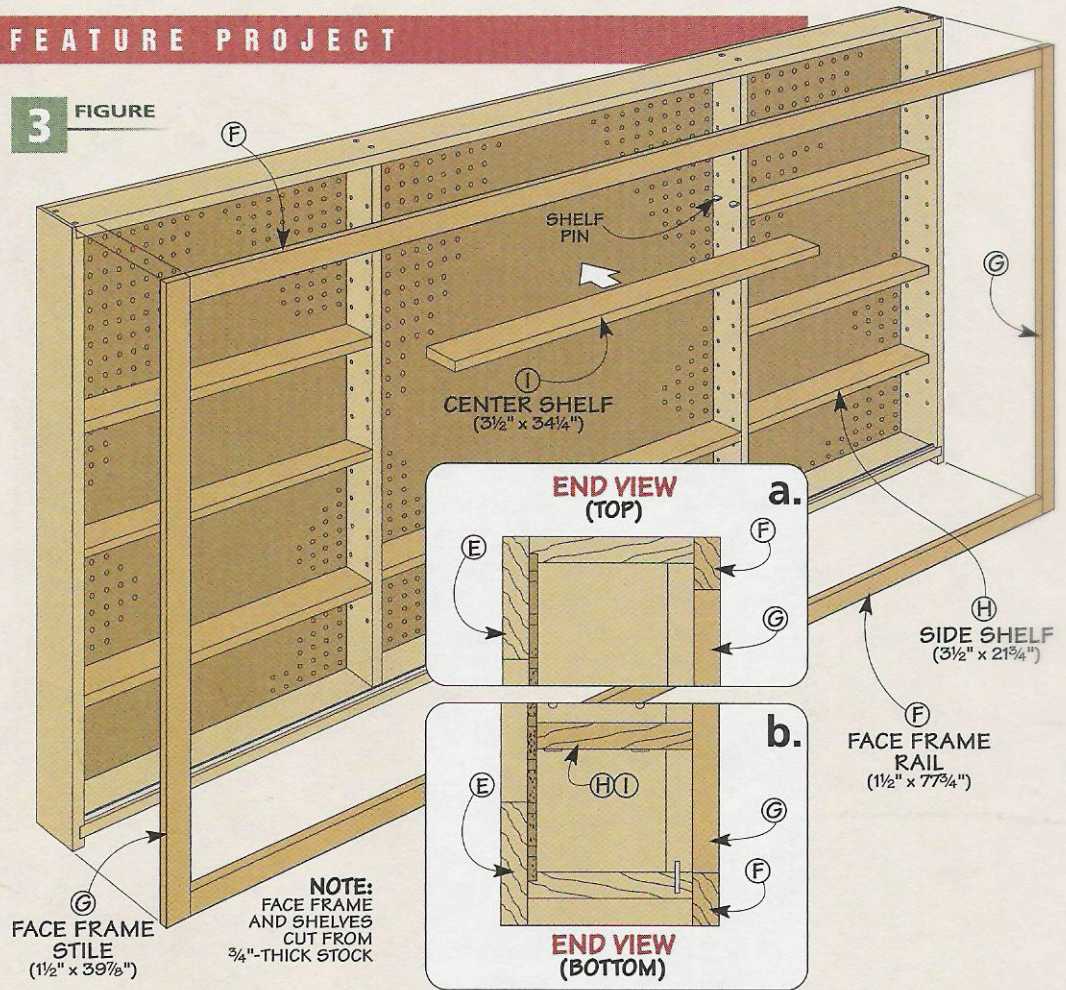

NOTE:
FACE FRAME
AND SHELVES
CUT FROM
3/4\"-THICK STOCK

strip fit snug in the kerf, but if yours is a little loose, you may want to use some epoxy to hold it in place.

Face Frame – The last two steps to complete the case are to add the face frame and shelves. These are both about as straightforward as

could be. The rails and stiles for the face frame are simply cut to size and glued in place to the front edges of the case. Then the shelves are cut to width and length. If you take a look at Figure 3, you'll notice that there are two different shelf lengths.



▲ **Shelf Pins.** Removable shelf pins are used to support the adjustable shelves inside the pegboard storage cabinet.

Buying Pegboard

Pegboard (also called per-board) is really nothing more than hardboard with holes drilled in it. But all pegboard isn't created equal. (Something you'll quickly discover when you start shopping for it.)

Thickness – You can find pegboard in 1/8", 3/16", and 1/4" thicknesses. Both the 3/16" and 1/4" pegboard have 1/4"-dia. holes, but the thicker pegboard will be much stronger, making it a better choice for shop projects like the storage cabinet.

In addition to different thicknesses, there are also different grades of pegboard. I prefer *service-tempered* pegboard. It's harder and more durable than standard pegboard. The only trouble is finding it — you may have to go to a lumberyard or have it ordered.

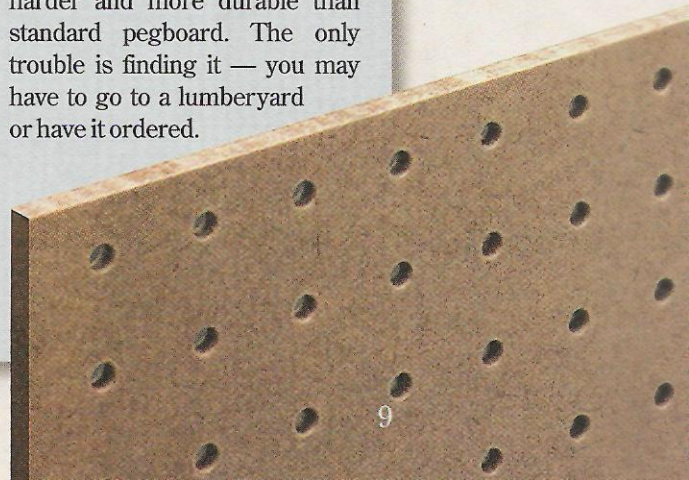

Sliding Doors

The sliding doors are what really make this cabinet special. Instead of simply sliding in a groove, these doors glide on roller mechanisms. Mounted into the bottom edge of each door are two sliding screen door rollers (see lower inset photo at right). These rollers work so smoothly that you can roll the doors along the track with one finger, even when they're loaded up with tools.

Each door is just a wood frame with a pegboard panel, as you can see in Figure 4. So I started by cutting the door rails and stiles to size.

The rollers fit into a deep groove that is cut in the bottom edge of the lower door rail before the door is assembled (Figure 4b). You'll also need to cut a shallow groove in the end of each door stile to allow the door to clear the aluminum track. Then you can glue up the doors and install the rollers.

Door Stops - Before you can install the doors in the case, there are a couple of details to take care of. To support the top of each door, I



▲ **Washer.** Loosely mounted fender washers serve as bearings at the top of the door.

▲ **Rollers.** Screen door rollers allow the pegboard doors to glide effortlessly on the track.

added some door stops to the inside of the case (Figure 5). To make sure that the doors would have plenty of clearance, I positioned the stops 1" away from the face frame. This creates a channel to help guide the door.

Washers - To keep the doors from rattling inside the case, I attached a couple of 1"-dia. fender washers to the top edge of each door, like you see in the top inset photo above. But I didn't tighten the screws all the way down. This allows the washers to spin freely, so they act as roller bearings inside the channel.

After adding a handle to each door, all you have to do is slip the doors into the channel and over the aluminum track, see photo above.

4 FIGURE

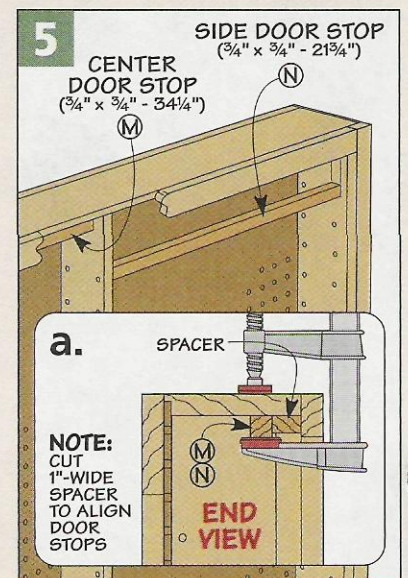
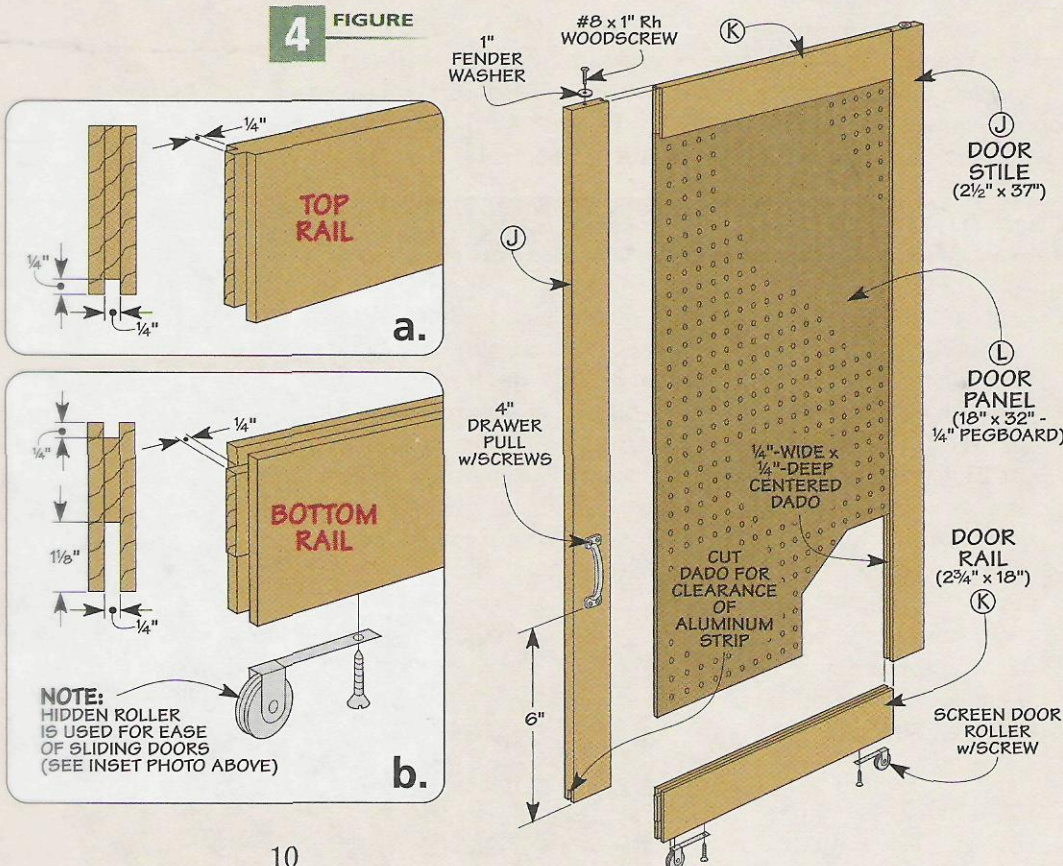

Optional Hardware Bin Rack

The pegboard storage cabinet is great for tools and supplies. But if you want to get even more use out of the cabinet, you can build this optional hardware bin. Mounted to the underside of the cabinet, the bin rack is just a series of cubby holes that are sized to hold plastic storage bins.

To make the bin rack, start by cutting the top and bottom to size. Then cut a series of evenly spaced dadoes on the inside face of each piece to hold the dividers (see detail 'a'). The ends of the bin rack are rabbeted to hold the top and bottom. And the dividers are cut to fit in the dadoes.

Before assembling the rack, I cut a kerf near the back edge of the bottom for some hardboard stops that will be added later. (The location of this kerf will depend on the size of the plastic storage bins that you're going to be using.)

Stops - Once the rack is assembled, you can cut some bin stops out of 1/4" pegboard and

glue them into the kerf all along the back of the rack.

Before you can mount the bin rack to the storage cabinet, you'll need to add a strip of wood to the top of the rack to act as a spacer between the rack and the recessed bottom of the cabinet. Once this is done, the rack can be attached to the cabinet with woodscrews.



Hardware Storage. This optional storage unit mounts to the bottom of the cabinet and holds up to sixteen plastic hardware storage bins.

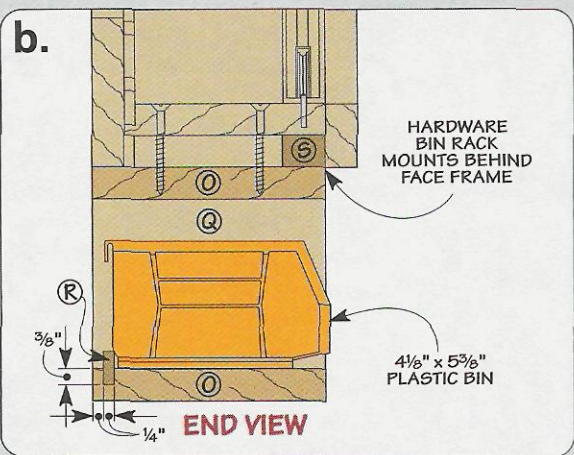
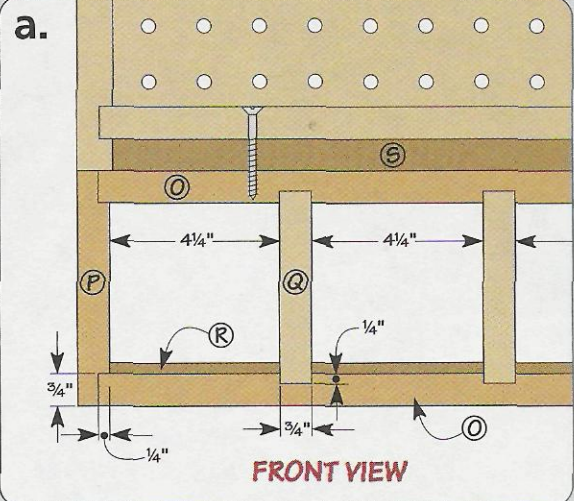
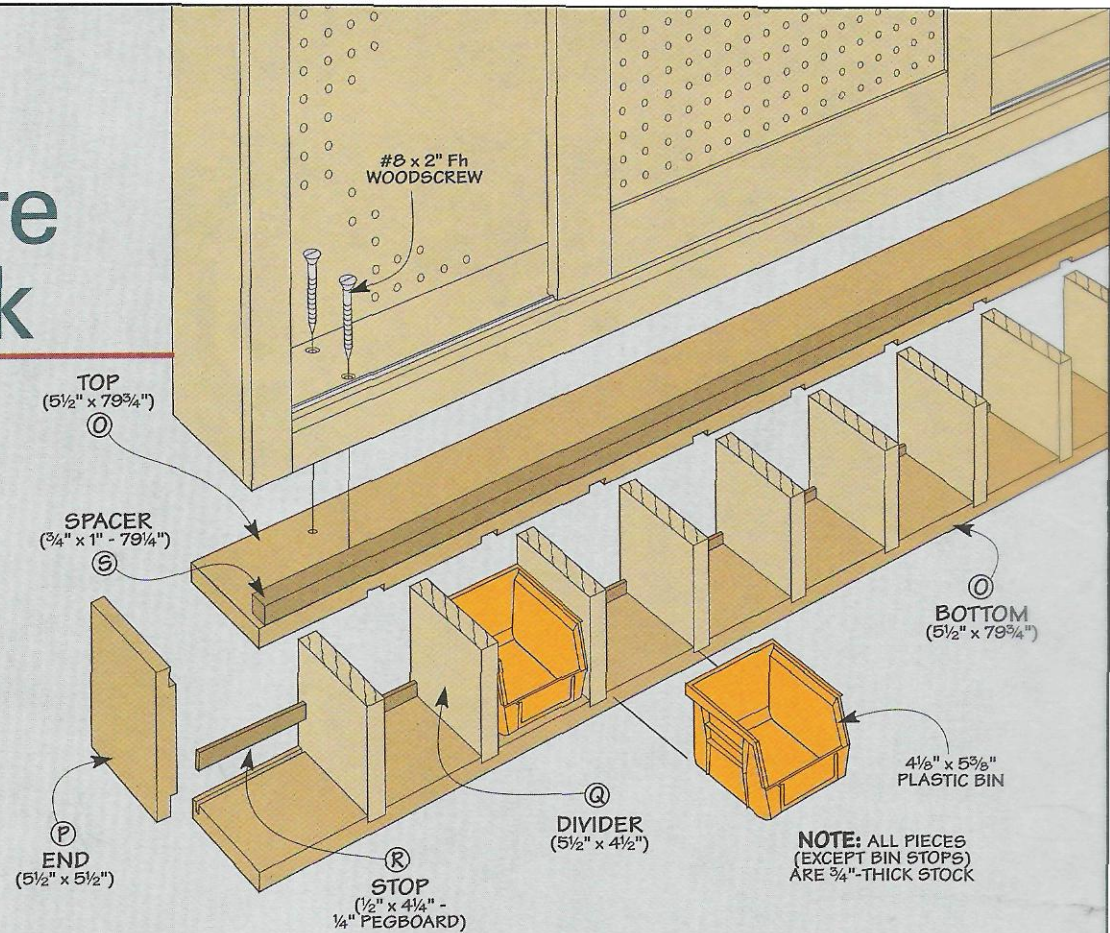

9-Step Table Saw Tune-Up

An afternoon is all it takes to tune-up your saw for peak performance and precision results.

Like most things with moving parts, a table saw requires periodic maintenance and upkeep to keep it running at peak performance. Unfortunately, it's all too easy to put off a tune-up to the point where your cuts aren't accurate or the controls become stiff and stubborn to adjust.

But there is an upside. Keeping your table saw clean, well-adjusted, and lubricated doesn't take all that much effort, time, or a lot of specialized tools. As a matter of fact, you really don't need much more than what you see in the photo above. In a short afternoon, you can have your table saw running great, with smooth and precise cuts to show for your efforts.

1. Start with a Good Scrub

One of the most important things you can do to keep your table saw in top shape is a simple cleaning once a month. If sawdust, pitch, and resin are allowed to build up inside the cabinet, it won't be too long before worm gears are gummed up and cranks become difficult to operate. This can be a constant source of frustration any time you try to adjust the saw blade.

To start the process, the first thing to do is unplug your saw and then use an air compressor to blow

► **Keep It Clean.** Common shop solvents are all you'll need to clean off the caked-on pitch and resin that builds up inside a table saw.



off sawdust trapped around the trunnion area, below the table top, and inside the cabinet. Then once that's complete, you can go right to work on the trunnion with a toothbrush and solvent to scrub away the pitch and resin build-up (photo at right).

Just about any shop solvent will work here (see bottom of preceding page). Just be sure to avoid lacquer



thinner which can strip the paint off the metal. And keep the solvent away from any bearings. The solvent can penetrate the bearings and dissolve the lubricants inside, shortening the life of the bearings.

If you're working a really stubborn area, you may find it necessary to use a brush to saturate the area with solvent and then let it set for a while (left photo). And if the build-up is really difficult to remove, you can try to break it free with a brass or wire brush.

With the inside of the saw all cleaned up, this is a good time to add some lubrication. I like to use a dry lubricant like the spray version shown in the main photo. It's less likely to attract dust and chips.

At this point, you can turn your attention to the top of the table saw. Although it's not likely to be caked with pitch and resin, it can have a different kind of build-up — rust.

◀ *Sweep Up.* Use a bristle brush to soak pitch and resin build-up with solvent and help loosen it up.



The most effective way to deal with this is to use a fine grit (400 - 600) sandpaper or abrasive pads. I like to use mineral spirits as a lubricant and "wet sand" any area with rust on it.

▲ *Brush It Away.* Heat the handle of a toothbrush and bend it an angle to get at hard to reach areas.

Once all the rust is removed, apply a coat of paste wax to the top of the table. And while you're at it, it doesn't hurt to wax the fence rails, and fence face. You'll notice the difference when adjusting the position of the fence or sliding a workpiece along its face.

2. Adjust Blade Raising & Tilt Mechanisms

A couple of the most important parts of the table saw are the mechanisms that allow you to adjust the height or angle of the blade.

Have you noticed that the crank turns a little bit (or maybe a lot) before the blade starts to raise? Or the angle of cut changes slightly after a few cuts? This extra "freeplay" is commonly called backlash and it's something you'll want to take care of to improve the accuracy of the cuts you make.

The nice thing is, most contractor and cabinet saws have a means to adjust the mechanisms and remove the backlash. It's best to check your owner's manual to verify the correct procedure for your saw. But in most cases, this requires a little "tweaking" of the fit between the worm gears and cogged "wheels" inside the saw. You can see what this looks like in the photo at right.

In many saws, the worm gear is mounted slightly off-center on the end of a shaft that runs through a sleeve. This allows you to loosen the locking nuts on the sleeve and adjust the position of the worm gear and fit the cogged wheels more tightly.

Once that's complete, it's just a matter of retightening the locking nuts to hold the sleeve in place. Then be sure to double-check any adjustments by running the blade height and tilt mechanisms through their full range of motion to check for any backlash. You shouldn't feel any looseness anywhere in that range.

As you adjust each of the mechanisms, you'll want to be sure you don't make things too tight. If the gears are too tight, it will be hard to adjust the blade. Plus, you'll put extra wear and tear on your saw — and that will just cause more problems down the road.

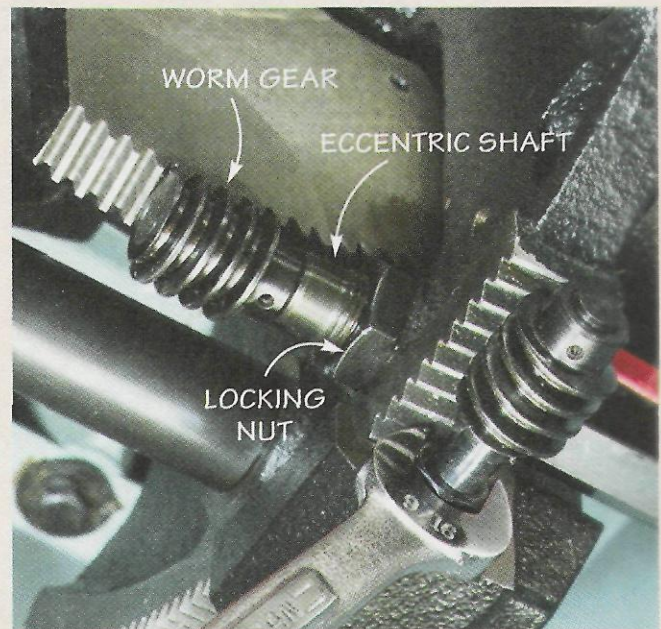

▲ *Backlash.* You can take out the backlash in the blade raising and tilting mechanisms by simply adjusting the worm gears inside the saw.

3. Checking for Runout

There are a number of things that play into how smooth a table saw runs. But if the arbor, flange, and blade exhibit any “wobble,” or runout, due to misalignment or looseness, all the tuning in the world won’t make a lot of difference.

You can do a “rough” check of the arbor by pulling up and down on the shaft, and then moving it in and out. You shouldn’t feel any play. And rotating the shaft by hand should be smooth and quiet.

For a more accurate check of the arbor, you can use a dial indicator and a shop-made holder, like you see in the upper photo at right. The holder is nothing more than a couple pieces of hardwood held together with a carriage bolt and knob. A hole and bolt at the end of the assembly

allow you to position the dial indicator exactly where you need it.

With the indicator resting on the arbor, rotate the shaft (upper photo). Any runout will show up as movement on the indicator. In a similar manner, you can position the indicator to check the flange (lower photo).

So what’s too much runout? Since any runout here will translate into even more at the blade, it can affect the quality of the cut. So I don’t like to see anything over 0.001" on the arbor or 0.003" on the flange. Anything more could be a sign of a bent arbor or bad bearings — something you can’t take care of with a simple tune-up.

If you want to minimize any blade runout you do have, be sure to check out a couple of the after-market accessories shown on page 17.

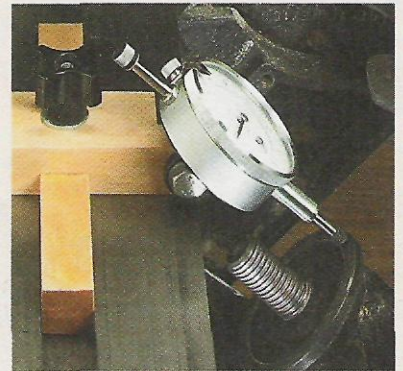
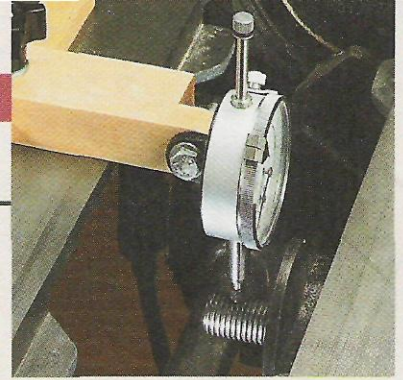

▲ *Read the Runout.* A dial indicator is an accurate method for checking the runout of the table saw arbor (top) or flange (bottom).

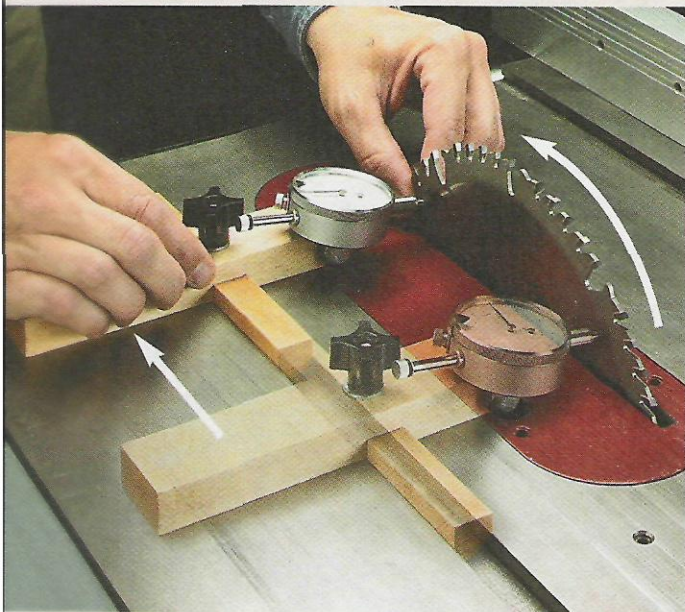

No matter how well your saw checks out for runout, it still won’t make a smooth cut if the saw blade isn’t aligned parallel to the miter gauge slots.

To check this, start by marking an ‘X’ on the saw blade. Next, position the dial indicator so the tip of the spring-loaded shaft contacts the blade on the ‘X,’ as in the photo above.

After “zeroing out” the dial indicator, rotate the saw blade and slide

4. Blade & Miter Slot Alignment

the gauge back so the plunger contacts the blade at the ‘X’ once again. Note: Rotating the blade ensures that any small runout in the saw won’t affect the reading.

If the reading remains the same, the blade is aligned. If it doesn’t, you’ll need to align the saw blade. For most saws, this means adjusting the trunnions. (Cabinet saws are adjusted by shifting the table.)

Adjust Trunnions – The front and rear trunnions are bolted to the underside of the table and support the carriage and arbor assembly. Adjusting them is simply a matter of loosening the bolts that hold them in place and shifting them to bring the saw blade into alignment.

But first, it helps to remove the belt and motor. Besides reducing the excess weight, this also makes it easier to reach the trunnion bolts.

Now you’re ready to adjust the trunnions. The trick here is to just loosen the bolts. And I find it best to leave one of the front bolts slightly snug. This way, it acts as a pivot point and keeps things from moving too

much. The bolts should be just loose enough so you can tap the rear trunnion into alignment with a piece of scrap and a mallet (photo below).

But the trunnion can move as you retighten the bolts. So it’s always a good idea to recheck the blade alignment as you did before to make sure the adjustment is correct.

Sometimes, no matter how hard you try to shift things into alignment, it just doesn’t work. If that’s the case, you might want to check out the trunnion alignment kit on page 17.

▼ *A Little Tap.* To align the blade with the miter slot, loosen the trunnion bolts and tap the trunnion into alignment.



5. Align the Motor & Pulleys

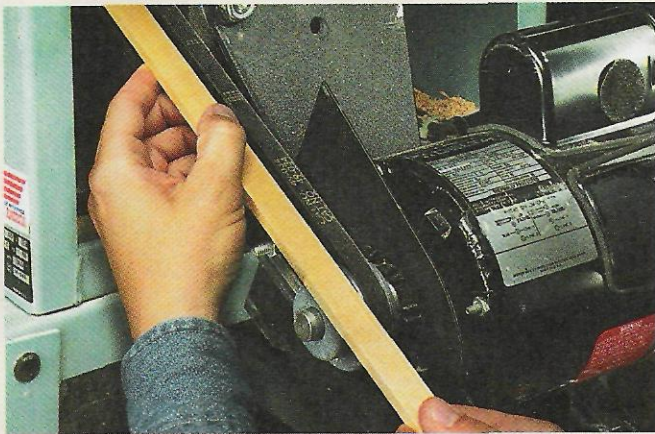

Now that the blade is aligned, you can reinstall the motor and belt. And to make sure your saw runs smooth and vibration-free, you'll want to check the alignment of the motor and arbor pulleys.

I did this by resting a straightedge against the outside faces of the two pulleys (see photo). What you want is for the straightedge to rest flush against each pulley. If it doesn't, you can bring them into alignment by shifting the pulleys on the shafts, or by readjusting the motor on its mounting plate.

Finally, give the drive belt a quick check. If it's worn, cracked, or frayed, you might want to consider upgrading to a link-belt and a set of machined pulleys (refer to page 17).

6. Keep it on the Level

Aligning the motor and arbor pulleys completes the inside work. The next step is to start working on the outside by "aligning" the entire working surface of the table saw. This is just a matter of leveling the throat insert and extension wings to the saw table.

Insert – To prevent the workpiece from catching as you make a cut, the insert needs to sit flush with the saw table. In addition, it should be stable so it doesn't rock back and forth as a workpiece slides over it.

On most saws this adjustment is made using four set screws located in

the insert, as you can see at right. To check your adjustment, a straightedge placed across the saw table should lie flat against the insert.

Extension Wings – Leveling the extensions wings isn't all that different than adjusting the insert — all you need is a longer straightedge.

This time, lay the straightedge so it spans the table and wings (see photo). If either wing needs adjustment, loosen the bolts underneath, shift the wings, and then retighten the bolts. Be sure to recheck the wings after making any adjustment.



▲ **Level It.** With common shop straightedges, you can easily level the extension wing and saw blade insert.



7. Set the Stops

Aligning the saw blade is only one part of getting an accurate cut. To make precise cuts at common angles, like 45° and 90°, most saws have built-in stops. The problem is, these stops can move out of adjustment over time.

Making Adjustments – There are several different methods for adjusting the stops depending on the table saw model. So you'll need to check the manual for your saw.

One of the more common methods uses set screws tapped into

◀ **Setting Stops.** A drafting triangle can be used for checking the 90° (left) and 45° (right photo) settings.

the top of the saw table. So all you need is an Allen wrench to make this simple adjustment.

Start by raising the blade to full height. Then use a drafting triangle to check and set the blade to 90°. Finally, adjust the set screw to match that setting (see photo).

Once you've set the stop, make a quick check by tilting the saw blade and then returning it to 90°. For the 45° stop, simply repeat the process, as shown in the photo at right.

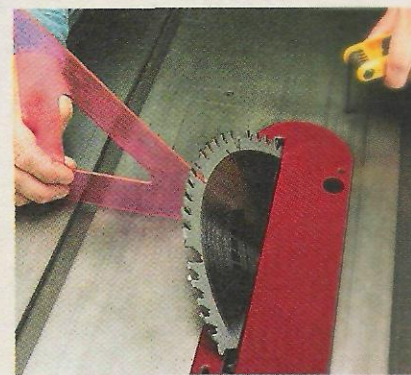

8. Miter Gauge & Rip Fence Check

Rip Fence – Just like the miter gauge, the rip fence needs to be aligned with the saw blade to accurately rip a board to width. If it isn't, a number of things can occur.

For starters, you'll end up cutting a wider kerf than necessary. This puts a heavier load on the motor and requires more effort to push a workpiece through the saw blade. It can also produce a rough or burnt edge, or even result in kickback.

To check the alignment of the fence, I used my shop-made holder and a dial indicator, as in the photo

below. Here again, the distance from the face of the fence to the miter slot should be the same all along the fence. If it isn't, you'll need to make an adjustment. For specific instructions, it's best to consult the owner's manual for your table saw.

The rip fence also needs to be square to the top of the saw table. A plastic triangle makes quick work of this check (inset photo below).

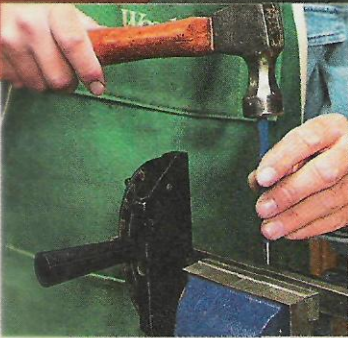

Now that the stops are adjusted, you can focus on tuning up the two most important accessories you'll use with your table saw — the miter gauge and rip fence.

▲ Punch in the Fit.

To tighten up a loose miter gauge, use a punch to add a few "dimples" to the edge of the miter gauge bar.

Miter Gauge – To make accurate crosscuts, your miter gauge needs to be properly aligned.

The first thing to check is whether the miter gauge fits in the slot without any play. To tighten up a loose fit, check out the insert photo at left.

Once you have it sliding smoothly back and forth, use a drafting triangle to set the stops for the 45° and 90° settings on the miter gauge (main photo above). Just align the head with the saw blade, and then adjust the stops on the miter gauge to match.

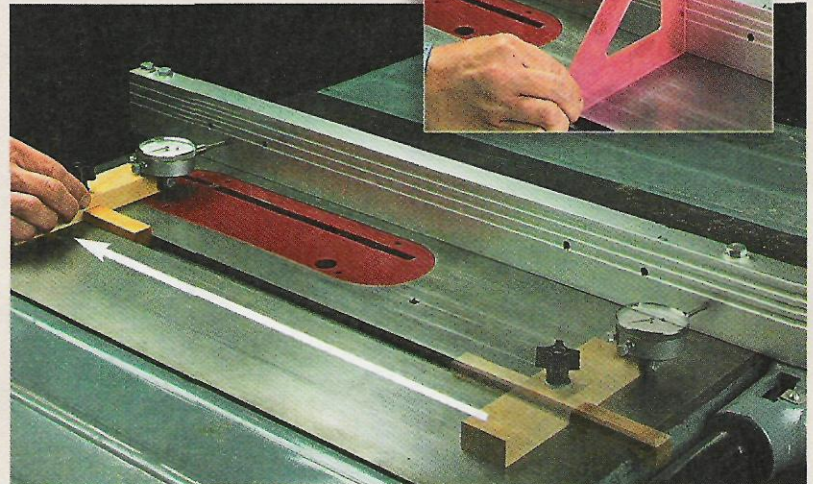

9. Adjust Splitter, Pawls, and Guard

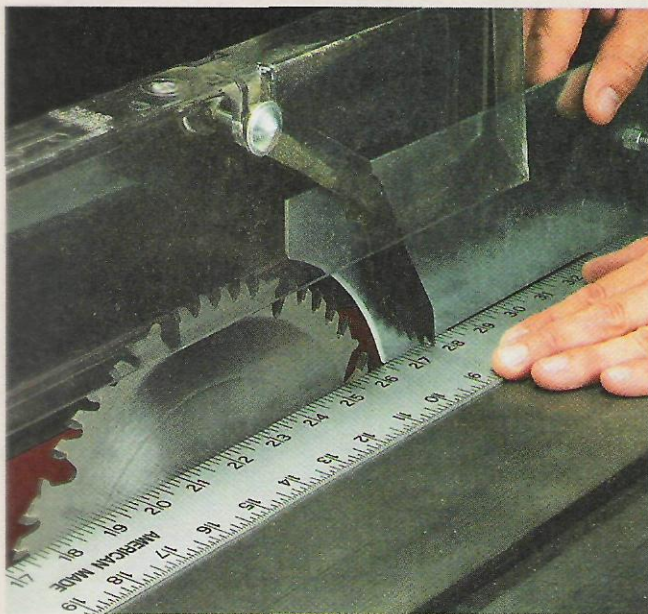

All that's left at this point in the table saw tune-up is to check and adjust the table saw splitter, pawls, and blade guard — a safety must.

Because the splitter, pawls, and guard help prevent mishaps, it's important to keep these items working properly all the time.

To make sure the workpiece doesn't catch the edge of the splitter as you make a cut, it needs to be aligned with the saw blade. A straightedge makes it easy to check the alignment (left photo). And while you're at it, make sure that the splitter is perpendicular to the saw table (right photo). Then tighten all the mounting bolts and double-check everything.

Next, check that the blade guard rides up smoothly over the workpiece as it moves past the blade. And finally, to prevent kickback, verify that the pawls "grab" the workpiece as you try to pull it back. You can sharpen the teeth for a better "grab." 

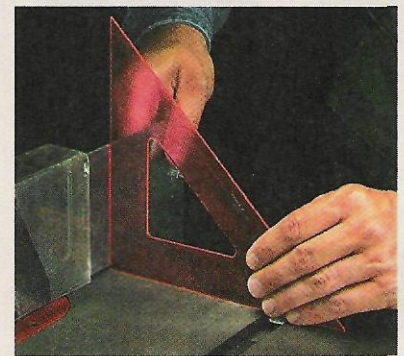

Hi-Tech Tune-Up Tools

You can bring your table saw to peak performance by following the steps on the preceding pages. But there are some “hi-tech” products that can make the whole process easier and more accurate. (For sources of the products mentioned below, refer to page 35.)

Dial Indicator Kit – One of the first I would recommend is the Basic A-Line-It kit from *In-Line Industries*. It's shown in the photo at right. The kit consists of a dial indicator and a pair of machined aluminum bars that screw together. One bar fits the miter slot and can be adjusted for a snug fit. The cross bar holds the indicator at whatever position you need it. They also make a more advanced kit with a few more accessories.

Truing Disc – If your checks should indicate a runout problem, there is a product available that will allow you to minimize it. And that's a truing disc by *Veritas* (see inset). The truing disc allows you to “tweak” the saw blade and correct the runout by tightening a series of set screws against the saw blade.

Dampener – Sometimes vibration from the motor or belt can cause a rough cut. *Forrest* makes blade stiffeners in three sizes (4", 5", and 6") that help dampen the vibra-

tion and improve the cut (right photo). But there is one drawback to using either the truing disc or a blade stabilizer. Both will reduce the depth of cut of the saw blade.

Belt & Pulleys – You can also minimize vibration by replacing your belt and pulleys with a link belt and machined pulleys, as shown below. To determine if a kit is available for your saw, contact *In-Line Industries*.

There's one last “hi-tech” product you'll definitely want to look at if you're having problems aligning your trunnions. It's called PALS (lower right photo). PALS stands for Precision Alignment and Locking System. Attached to the rear trunnion, PALS makes it a simple task to align the trunnion to your saw blade and then lock it in place so the trunnion can't move. Not bad for a \$20 product (again from *In-Line Industries*). 

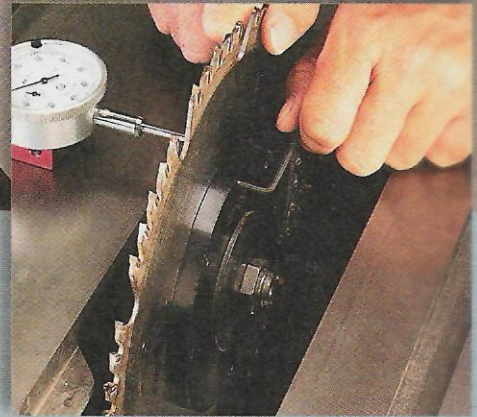

▲ **Zero Out the Runout.** With this saw blade truing disc, you can reduce the runout of your table saw to a minimum.

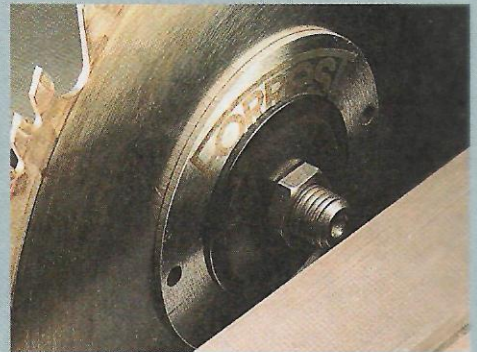

▲ **Stiffener.** Although it reduces the depth of cut, a blade stiffener is an inexpensive way to reduce saw blade vibration.

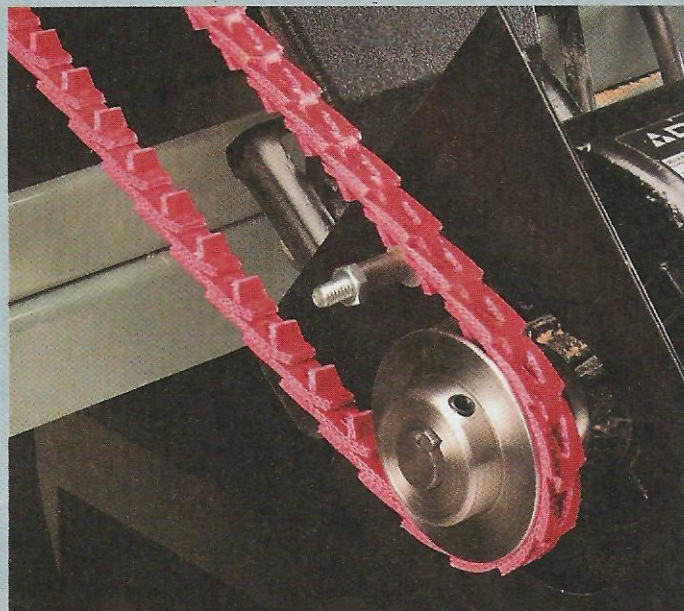

◀ **Belts & Pulleys.** A link belt and machined pulleys will make your saw run smoother.

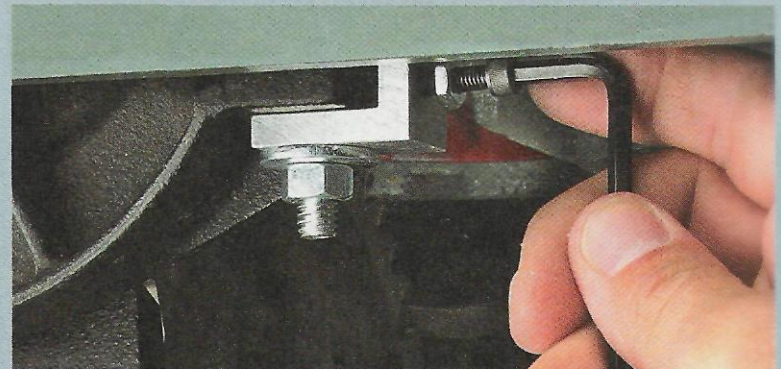

▲ **Trunnion Alignment.** For easy and precise trunnion alignment, nothing beats the Precision Alignment and Locking System (PALS).

Fold-Away Tool Stand



This adjustable, rock-solid tool platform folds flat to the wall when you need a little extra shop space.

My shop just isn't big enough to add another permanent work surface, so I built this fold-away tool stand. And it has quite a few things going for it.

Since the stand is mounted to the wall, it doesn't take up much space when it's in use. Then when you don't need it anymore, it folds up flat to the wall — out of the way (photo at left).

Another selling point is that the stand is fully adjustable. The top can be set to almost at an angle (and height) for a scroll saw. Or you can set it horizontal for other tools like a benchtop band saw or grinder, as shown on the back cover. You can even make a drafting table top (see page 21). And finally, you won't spend a lot of time making it.

The tool stand is made up of two assemblies — a wall frame and an adjustable top, as you can see in the photo on the opposite page. The top is connected to the wall frame with sliding blocks that make for fast, smooth adjustments.

By loosening the upper blocks and sliding them down, the top folds back against the wall, as shown in the inset photo on the opposite page. And this means you can use the blocks to position the top at whatever height or angle you like.

Don't worry that all this adjustability will make the stand wobbly. In fact, when the blocks are locked down, it's rock solid.

Wall Frame — I started building the tool stand by making the wall frame. It consists of a pair of rails and track guides that both support the work surface and anchor it securely to the wall.

The top and bottom rails (A) are cut from 3/4"-thick hardwood and screwed to two track guides (B) which have a groove cut in the front face. The groove is sized to fit a length of aluminum T-track, as shown in Figure 1a. This frame puts the T-track 16" on center. This way you can screw through the T-track and guides and into the wall studs, as illustrated in Figure 1b.

Don't assemble the wall frame just yet. You'll need to make the four sliding blocks (C) first. The reason is

1 OVERVIEW

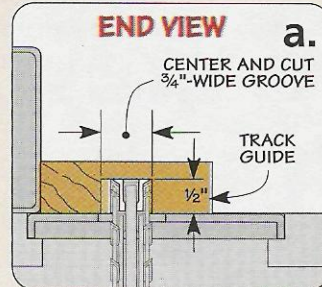
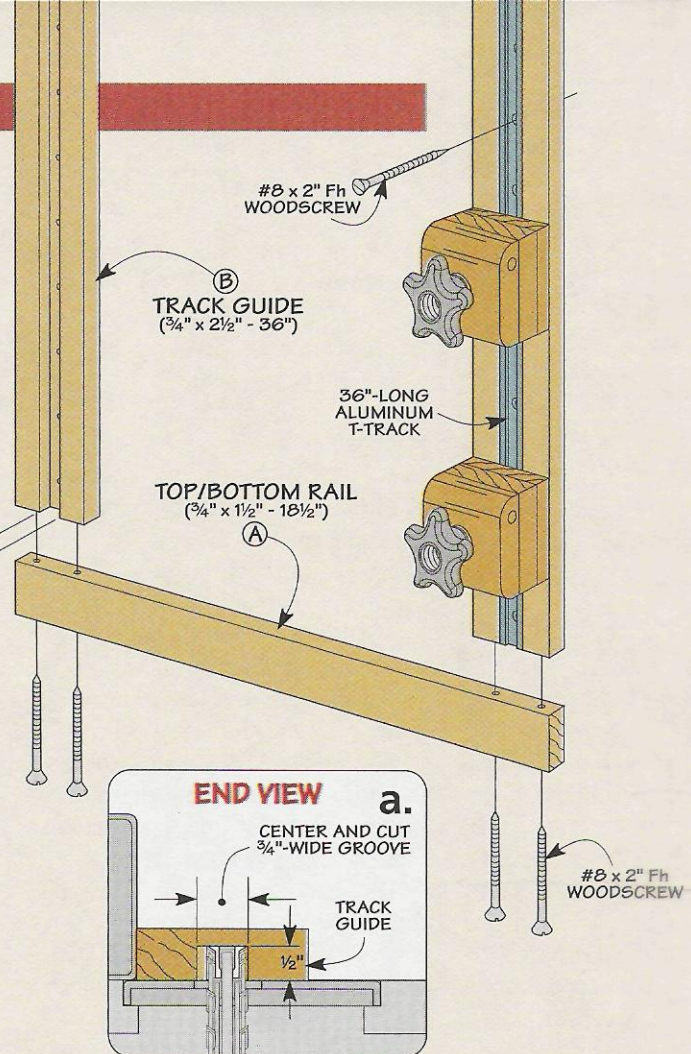
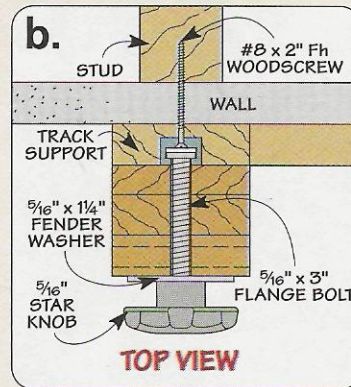
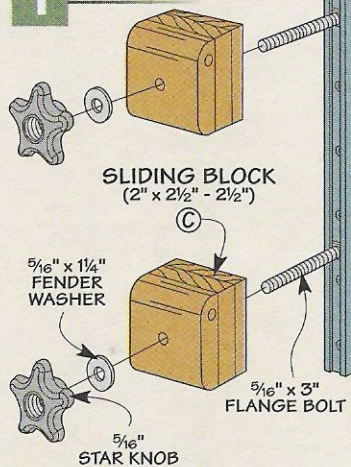

that the flange bolts need to be slipped into the track before you attach the top and bottom rails.

Sliding Blocks — Each sliding block is glued up from two layers of 3/4"-thick hardwood and one 1/2"-thick layer. To make the blocks consistent, I cut them from a single, extra-long blank, as in Figure 2.

Next, two holes are drilled in each block. One holds a flange bolt that secures the block to the T-track. The other hole holds a carriage bolt used to attach the braces and cleats of the work surface. After drilling the holes, I rounded over the top edges, slipped the flange bolts into the T-track and assembled the frame.

Materials & Hardware

- A Top/Bottom Rails (2) 3/4 x 1 1/2 - 18 1/2
- B Track Guides (2) 3/4 x 2 1/2 - 36
- C Sliding Blocks (4) 2 x 2 1/2 - 2 1/2
- D Cleats (2) 3/4 x 1 1/2 - 24
- E Braces (2) 3/4 x 1 1/2 - 32
- F Top Panel (1) 26 x 16 - 3/4 Plywood
- G Drafting Table Top (1) 26 x 36 - 3/4 Plywood
- H Pencil Stop (1) 1/2 x 1 - 36

- (2) 5/16" - 18 T-Knobs
- (4) 5/16" - 18 Star Knobs
- (2) 5/16" x 2" Carriage Bolts
- (2) 5/16" x 3 1/2" Carriage Bolts
- (2) 5/16" x 4 1/4" Carriage Bolts
- (2) 5/16" x 3/4" Nylon Spacers
- (4) 5/16" Lock Nuts
- (6) 5/16" Flat Washers
- (4) 5/16" x 3" Flange Bolts
- (4) 5/16" x 1 1/4" Fender Washers
- (2) T-Tracks (36" long)
- (6) #8 x 1 1/4" Fh Woodscrews
- (16) #8 x 2" Fh Woodscrews

2 FIGURE

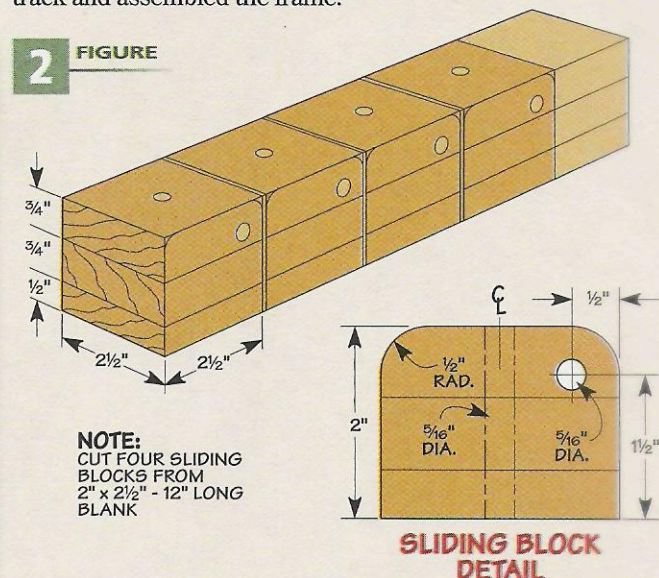

Worksurface

Once the wall frame and sliding blocks are done, you can begin making on the worksurface assembly.

Supports

The worksurface is attached to the wall frame with two supports, as shown in Figure 3. I started by making the supports with the cleats (D). They serve two functions. First, they add extra strength and rigidity to the worksurface. This will help prevent the top from flexing in use. The second thing the cleats do is provide the rear connection points for the upper sliding blocks of the wall frame.

The cleats are made from 3/4"-thick hardwood. The two lower corners of each cleat are rounded. Then a hole is drilled in each end to attach the cleats to the upper sliding blocks (Figure 3a) and the braces that are made later. I also drilled several shank holes for attaching the cleat to the top panel with screws.

Next, you can make the two braces (E). Like the cleats, they're cut from 3/4"-thick stock. But here, I rounded over the top and bottom of each end to allow the braces to pivot freely.

The braces are attached to the inside face of the cleats with a carriage bolt, washer, and lock nut

3 FIGURE

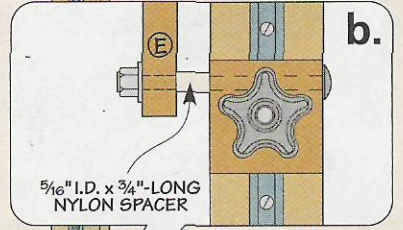
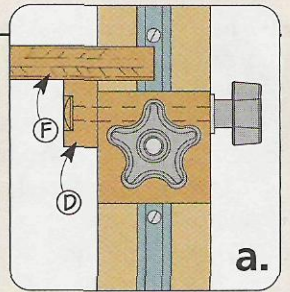
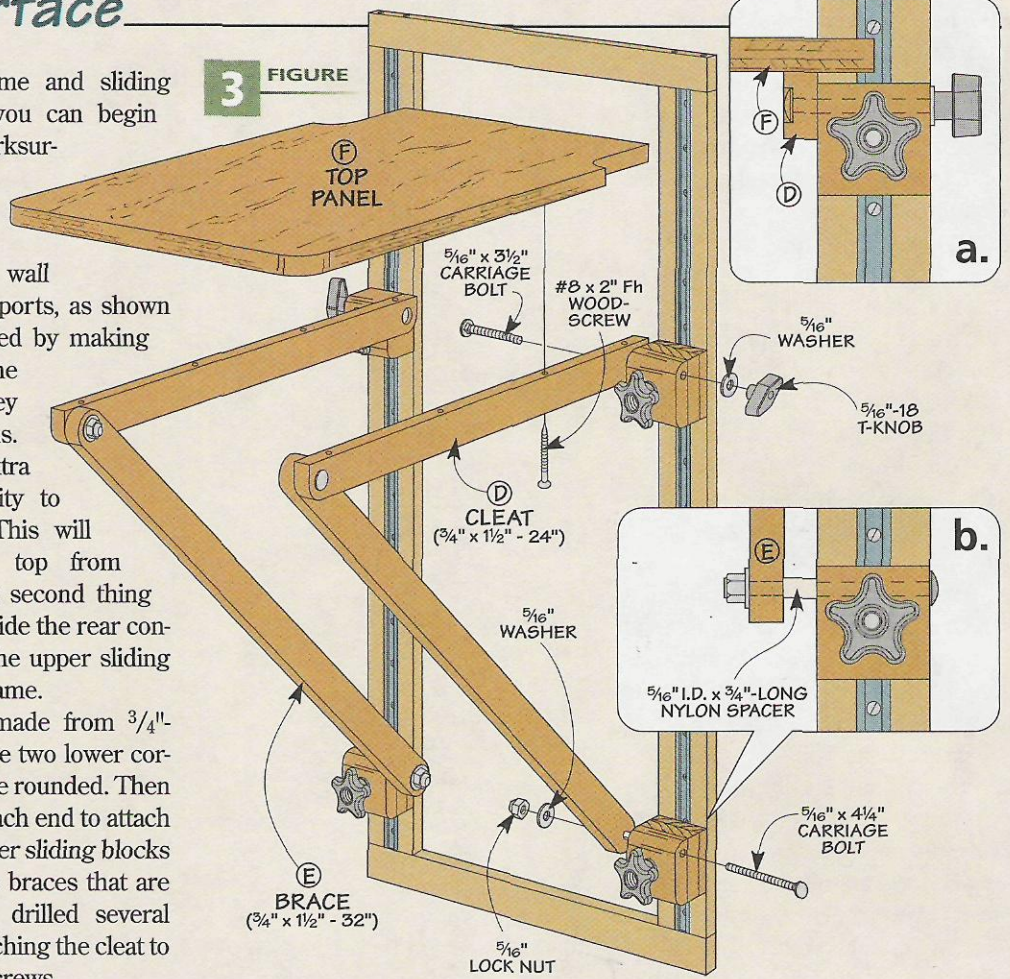

▲ **Folds Flat.** Nylon spacers on the lower sliding blocks allow the front braces to slip inside the cleats. This lets the top fold flat against the wall.

riage bolt, washer, and lock nut (Figures 4 and 4b). To connect the braces to the lower sliding blocks, I used a longer carriage bolt and installed a nylon spacer between the brace and the block, as you can see in Figure 3b. This keeps the brace properly aligned.

Top Panel - Now you can cut the

top panel (F) to size from 3/4" plywood. The front corners of the panel are rounded and there are a pair of notches at the back that provide access to the sliding blocks (Figure 4a). The top is simply attached to the cleats with long screws, as shown in Figure 4b. And all that's left is to drill mounting holes for your tool (or tools) and start using it.

4 FIGURE

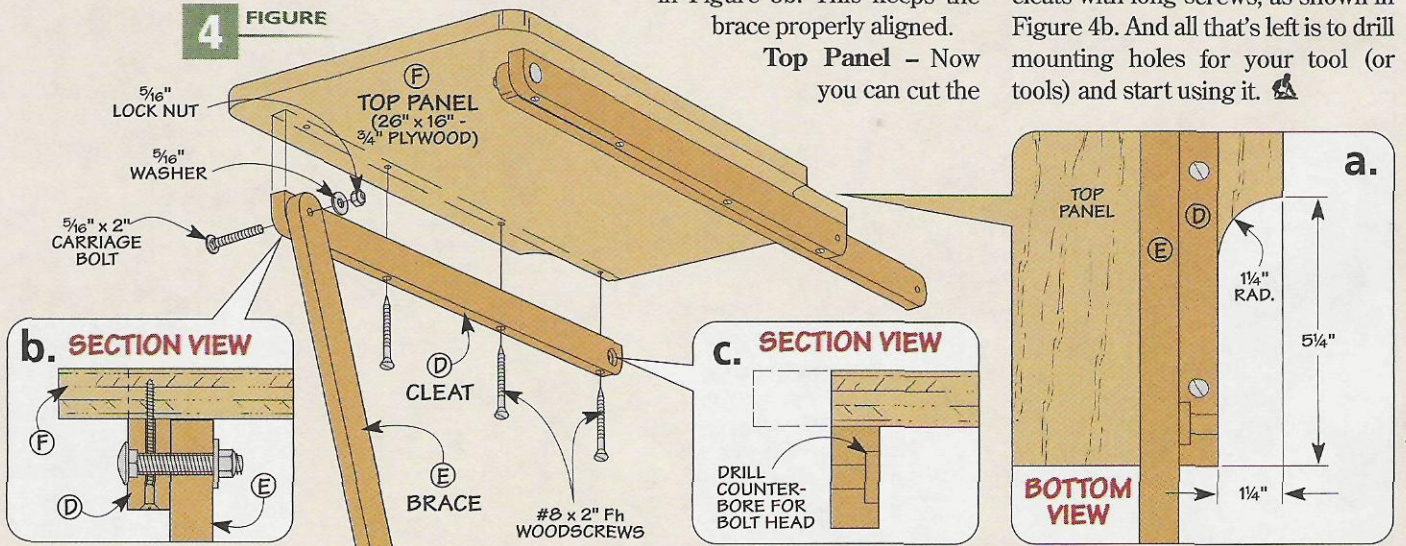

Optional Drafting Board



◀ **Out of the Way.** The drafting table almost disappears to open up more shop space.

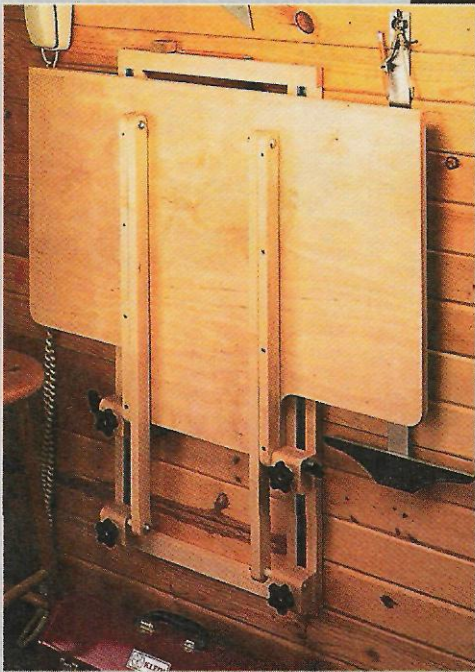

After building the tool stand, it didn't take long for us to come up with another use for it.

Alternate Top – One idea that came to mind was to make a drafting board top, like you see in the photo above. It's nice to have a place to sit down and do some drawing, but that's something I don't do everyday. So the now-you-see-it, now-you-don't nature of the fold-away tool stand makes it just the thing for my shop. And the flexibility of the sliding blocks lets me set the top at a comfortable height.

Best of all, you really don't need to change much. To make the conversion, all I did was make a larger *drafting table top* (G) out of $\frac{3}{4}$ " plywood. You can see the dimensions for it in the drawing at right.

Next, I attached a vinyl board cover made by *Borco*. You can find it at most art or office stores. It's held

in place with some carpet tape. The vinyl board provides a smoother and softer surface for writing and drawing than a plain plywood top.

Then to keep my pencils from rolling off the top and onto the floor, I added a small lip to the bottom edge. The *pencil stop* (H) is just a piece of $\frac{1}{2}$ "-thick hardwood with the top edges rounded over. It's simply glued to the edge of the top, as you can see in detail 'a.'

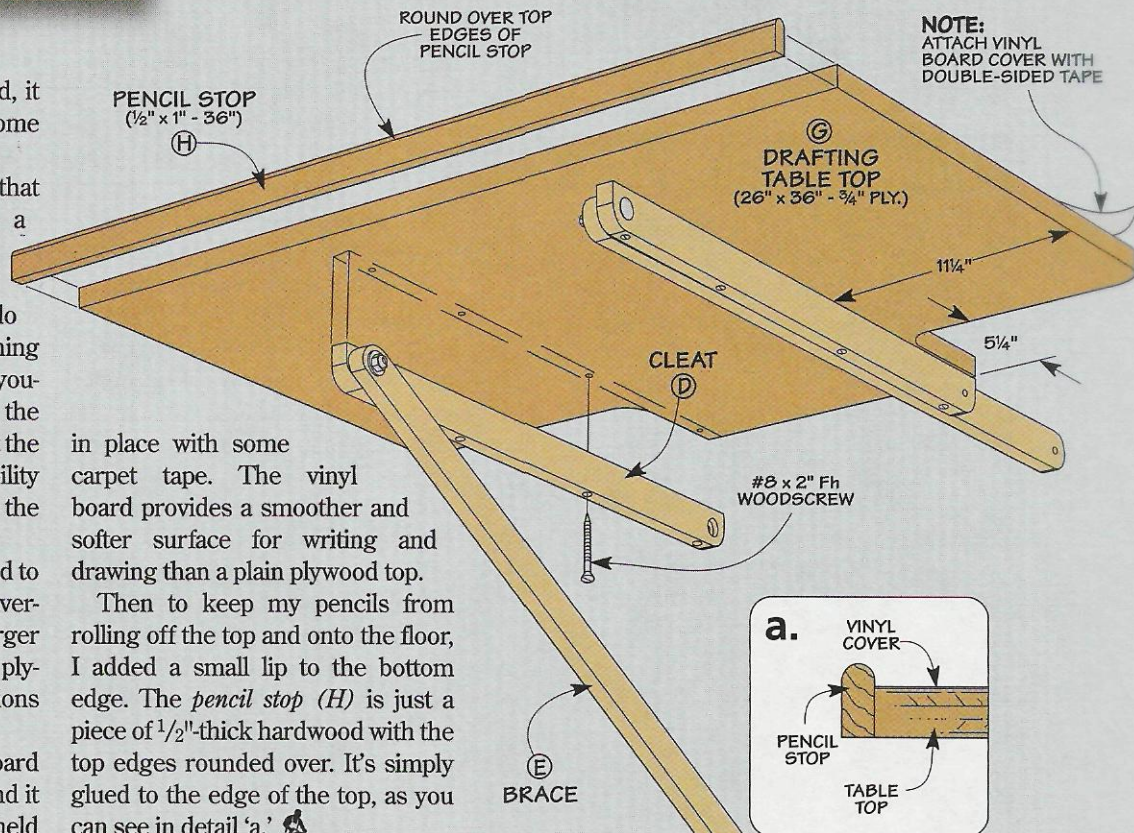



Making Tools Move

Put your shop on wheels to gain space, efficiency, and flexibility

Things to Consider

1. Does a universal base suit my needs, or should I purchase a dedicated base that's designed for my specific tool?
2. If the mobile base can be adjusted, how easy is it to make a change?
3. What are the minimum and maximum sizes the base can be adjusted to?
4. Is the base stable when moving the tool, and more importantly, is it stable once it's locked in place and you're working at the tool?
5. Does the base lock in place by foot-actuated levers or hand-operated knobs? How many? When locked, does it rest on wheels or pads?
6. How much assembly is required to put the mobile base together?
7. What's the maximum tool weight the mobile base will support?
8. Will the base handle extension tables or is there an accessory available to handle it?
9. How much will I have to spend?

Wouldn't it be great if you could change the location or position of your shop tools in minutes to suit the task at hand? Or rearrange your tools to accommodate a new purchase? Maybe you just need to "shove" things out of the way a bit to make a little extra room for assembling a large project or cutting a sheet of plywood down to size.

Wishful thinking? Not really. With a wide range of mobile bases available from a number of manufacturers, putting wheels under just about any tool, workbench, or work-surface is easy. This way, you can change your shop any time you want without any problems.

But with so many mobile bases available, what things should you consider when buying one? What do you really need? And what's really important? In the box at left, you can see the things you should consider before settling on a mobile base.

What Type of Base? – One of the first considerations when going

mobile is whether to buy a *universal* base that you can size to fit just about any tool. Or do you buy a *dedicated* base — one that's been designed to handle a specific tool?

Universal Base – As its name implies, a universal base is designed to be adjustable. This way, you can size it to fit a wide range of different tools. In most cases, this involves bolting together adjustable rails or bars so that the base of the tool fits inside the perimeter of the frame.

Dedicated Base – The other option is to buy a mobile base that's designed for a specific tool. Instead of adjustable rails, the rails are sized to fit the tool and then welded together. For more on dedicated bases, see the box on the opposite page.

Regardless of the type of base you choose, making your shop mobile is one of the simplest ways to "add" valuable working space, improve the overall efficiency of your shop, and just make working in the shop more enjoyable.

JET

One of the downsides of most universal bases is the time you have to spend assembling them (more on this later). Of course you only have to do this once (unless you want to change it for another tool). Still, you don't want assembly to be a hassle. And that's where the *Jet* universal base shines (photo at right).

Note: This base is rated for 600 lbs. *Jet* makes another mobile base for tools up to 1200 lbs.

Assembling the base takes a couple minutes at most. All you have to do is slip the steel bars into the corners, position them to match the mobile base to the base of your tool, and then "lock" everything in place with spring-loaded pins (see inset).

This ease of assembly does come at a sacrifice. Because the rails are held in each corner by a single pin and not bolted, the base isn't as rigid as I'd prefer. It has a little "flex" to it. You'll probably notice this most as

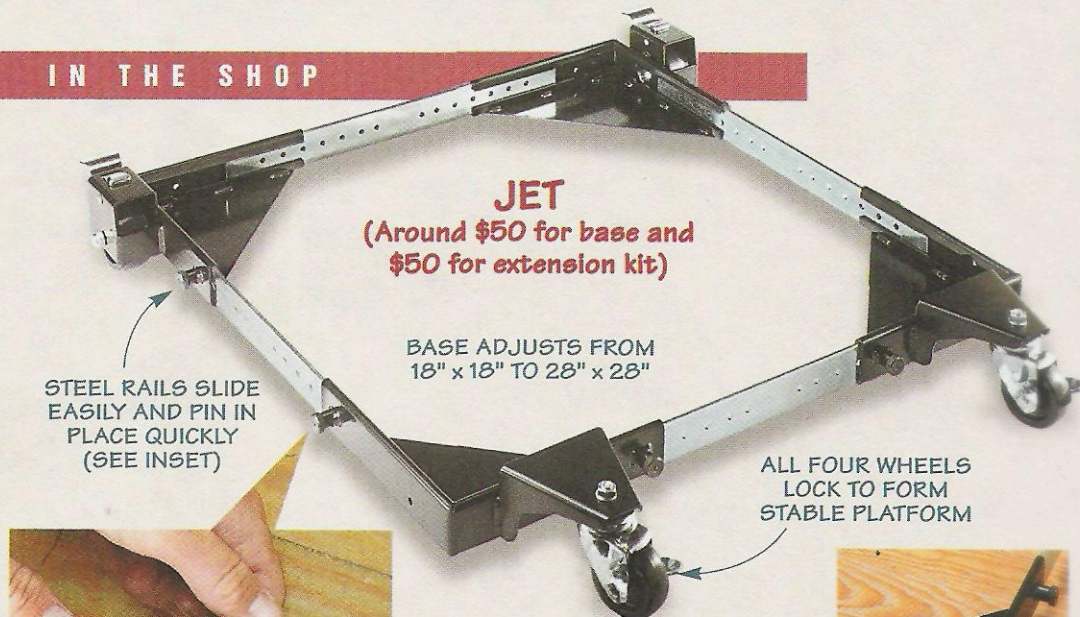

you move the tool around. But once the wheels are locked in place, the base (and tool) is quite steady.

Speaking of locking the base in place, that's one feature of the *Jet* base I really liked. I don't have to

bend over to lock any of the four wheels. Each one has a separate foot-operated lock, as you can see in the margin photo.

Extension Accessory – A handy accessory available for the *Jet* base is an add-on extension kit. It's designed to support table saws (or other tools) with large wing extensions, like the one you see in the photo on the opposite page.



▲ **Wheel Locks.** A simple press of each foot lever locks (or unlocks) the wheels of the base.

The Case for a Dedicated Base

Instead of a "one-size-fits-all" approach, you might want to consider a *dedicated* base, like the one shown at right.

Now you might be thinking that once a mobile base is under a tool, isn't it pretty much "dedicated?" What makes a dedicated base different is that it's designed to fit a *specific* tool (or power

class of tools, like 14" band saws).

The reason I prefer a dedicated mobile base is because it's engineered for a specific tool and the frame features welded steel construction. So the base (and tool) are solid, whether it's locked in place and you're using the tool, or you're moving it around the shop.

Some tool manufacturers make dedicated bases for their tools. But *HTC Products Inc.* has "dedicated" themselves to this type of base. They make a base for just about any tool. (They'll even custom make one for you.)

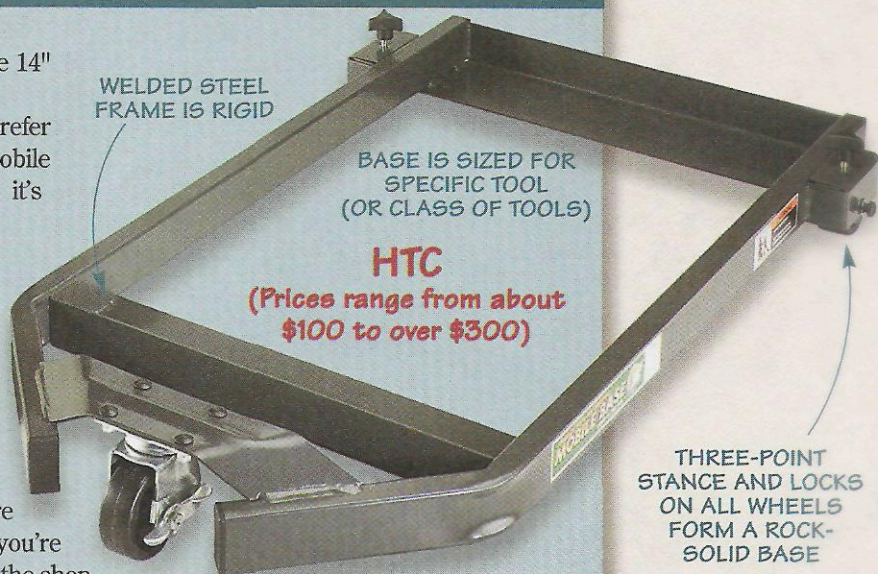

▲ **Wheel Locks.** All it takes to firmly lock the two fixed wheels of this base is a couple turns of a knob.

Cost – About the only downside to a dedicated base is the cost. It's probably going to run at least twice as much (or more) than a typical universal base. For sources of dedicated bases, see page 35.

Some (a lot of) assembly required. That's something that should be in big bold letters on the outside of most of the universal bases being sold today. And it's the case for the rest of the mobile bases shown here.

GENERAL

With over a hundred parts, you can expect to spend the better part of an afternoon putting the *General* universal base together. But once it's assembled, you'll be pleasantly surprised at how solid and well-built it is.

This *General* can be assembled to cover a wide range of tools (up to 500 lbs). That's because the rails are two-piece channel assemblies. You can use them singly to make a base to fit tools with a small footprint. Safety Note: Be careful not to use this setup with a top-heavy tool like a drill press. It won't be quite as stable as you roll it around the shop.

And when you need a larger base, just slip a set of channels together (they work like drawer slides) and tighten the bolts (see inset above).



▼ *Interlocking Rails.* Adjusting a pair of interlocking rails makes it easy to accommodate the *General* base for larger tools.



Moving the base (and tool) around the shop is a breeze. And once you have it where you want it, just flip the lever on the wheel assembly up and the base will rest on the leveler pads at the front of the base. You'll have to spend a little time "tweaking" the height of the pads to find a position where the base rests firmly on the pads, yet still allows the base to move easily once you press the levers to raise the base onto the wheels.

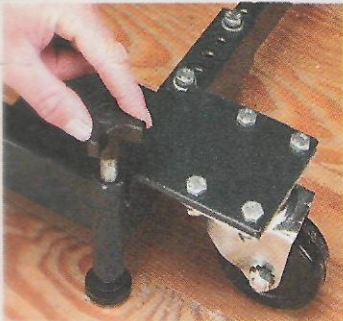
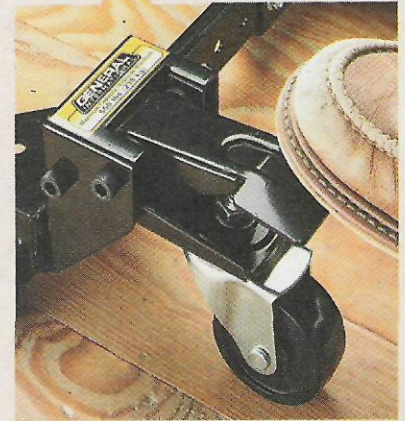

◀ *Foot Pads.* Turning a small knob raises the wheels off the floor, "locking" the base in place.

SHOP FOX

Another contender for "how many parts can we use in one base" is the *Shop Fox* shown at the lower left. Like the *General*, the *Shop Fox* has an assortment of over a hundred parts.

With heavy-duty, tubular steel construction, this base acts more like a dedicated base once it's assembled. It provides a hefty, rock-solid foundation for tools up to 700 lbs.

Unlike the *General*, there aren't any foot levers to raise and lower the base on the *Shop Fox*. Instead, there are a pair of leveler pads that you lower to lift the base off the wheels. Just a little turn and the base "locks" in place without any problem (see inset).

Besides the model shown (D2057), *Shop Fox* has two other versions of this base available to accommodate a wider range of tool sizes and weights. Also, extension kits are available to handle long and narrow machines or extension tables.

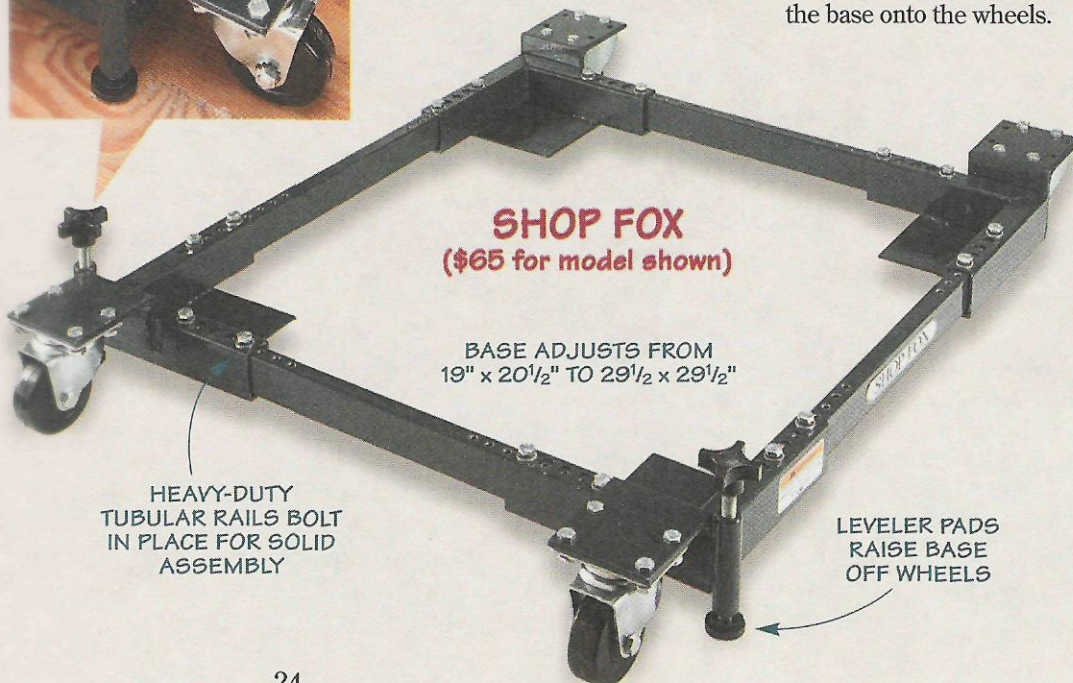

ROCKLER

So what do you do if the tool or workstation you want to make mobile won't fit the adjustability limitations of a "universal" base? Simple. Use a universal base where you make your own rails any size you want from hardwood stock. Both *Rockler* (shown at right) and *Delta* make a version of this type of universal base.

Instead of supplying rails or tubes to connect the corners of the base, the corners are designed to accept 1½" square pieces of hardwood. This way, you can mill the stock to any length you like (within reason, of course).

Once you have the rails made, all you have to do to complete the assembly is drill a few holes and bolt the rails in place. Then you can add a pair of leveler pads and a foot lever to the opposite end of the base.

The foot lever raises the base off the pads, like you see in the inset photo above. The lever is removable, so you can buy separate base kits and move the lever from one base to another as you need to. Which is a nice feature if you have a number of tools to add bases to.

Because you're using hardwood rails, this base has a little more flex

1½"-SQUARE HARDWOOD RAILS

LEVELER PAD



ROCKLER
(About \$50 for version with foot lever plus the cost of the hardwood rails)

FOOT LEVER/WHEEL ASSEMBLY CAN BE REMOVED TO USE ON OTHER BASES

BASE SIZE VARIES DEPENDING ON LENGTH OF CUSTOM-MILLED HARDWOOD RAILS

NOTE: BASE IS RATED FOR APPR. 300 LBS. WITH HARDWOOD RAILS

◀ *Going Mobile.* To make the *Rockler* base mobile, press the foot lever to raise the base off the leveler pads and onto the wheel.

than an all-metal or dedicated base. Especially with longer rails. And since the base is supported by a single wheel once it's mobile, it feels less stable as you move it around.

Once the base is planted firmly on the leveler pads, it's a fairly solid unit. Still, it's something to keep in

mind depending on the size of tool you plan to be moving around.

ANOTHER OPTION

If you have *cabinet-style* tools, there's one more option you might want to consider. You can read about it in the box below. 🛠️

Casters for Cabinets

There's another type of universal base that doesn't require any adjustment of rails to size it — and that's the set of casters shown at right.

Jet designed these casters for use with cabinet-style tools. The

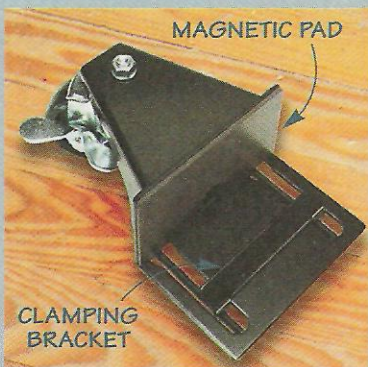

casters wrap around the bottom lip of the stand and clamp in place.

Installing them is a snap. Simply raise the cabinet off the ground slightly (3/4") and slip the casters in place. A magnetic pad on the inside face of each caster (lower left photo) holds it in place while you tighten the clamping brackets.

Once the casters are locked in place, moving the tool is smooth and easy. And foot-operated locks keep the tool solidly in place.

The casters are sold in sets of four. You can get an all-swivel set, or a set that has a pair of swivel casters along with a set of fixed casters. With either set of casters,

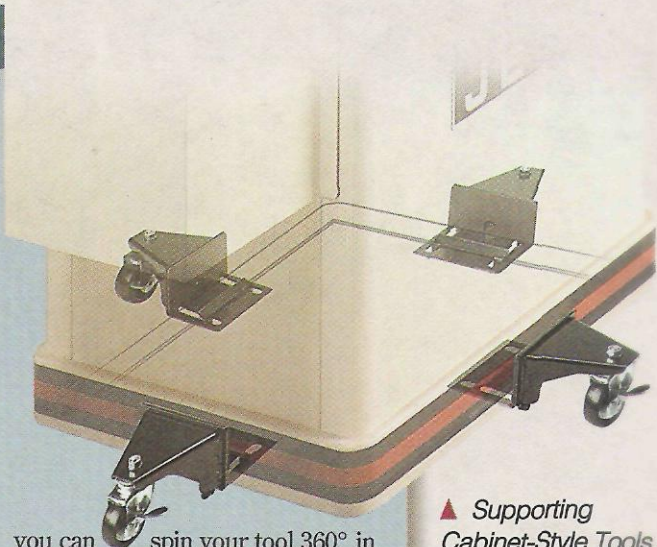

you can spin your tool 360° in place — a handy feature at times. Both sets are rated for up to 600 lbs. and sell for around \$60). For sources, refer to page 35.

▲ *Supporting Cabinet-Style Tools.* Make any cabinet base mobile by clamping this caster set to the lower frame of the cabinet.

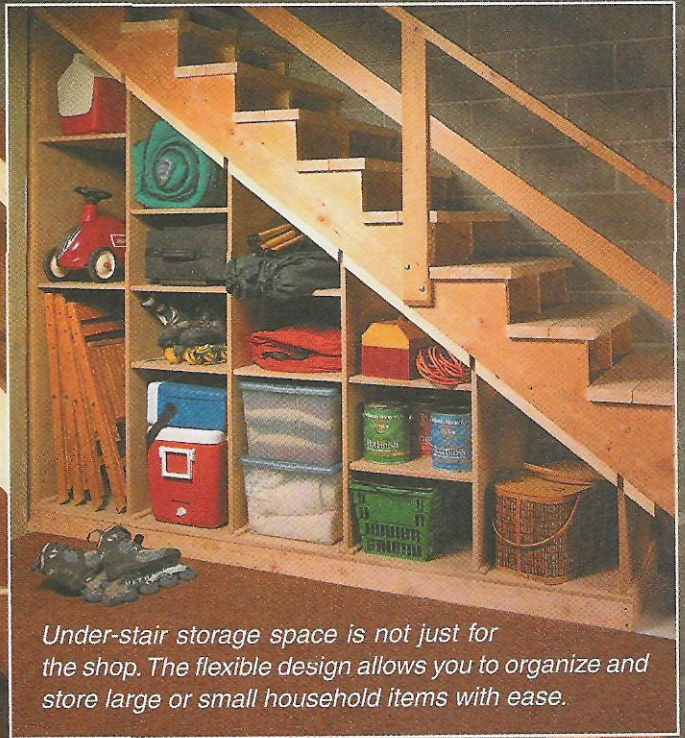

Under-stair storage space is not just for the shop. The flexible design allows you to organize and store large or small household items with ease.

Under-Stair Storage

Great storage space lies just beneath your stairs. With this simple design and common materials you can solve your storage problems in short order.

STORAGE PROJECT

1 FIGURE

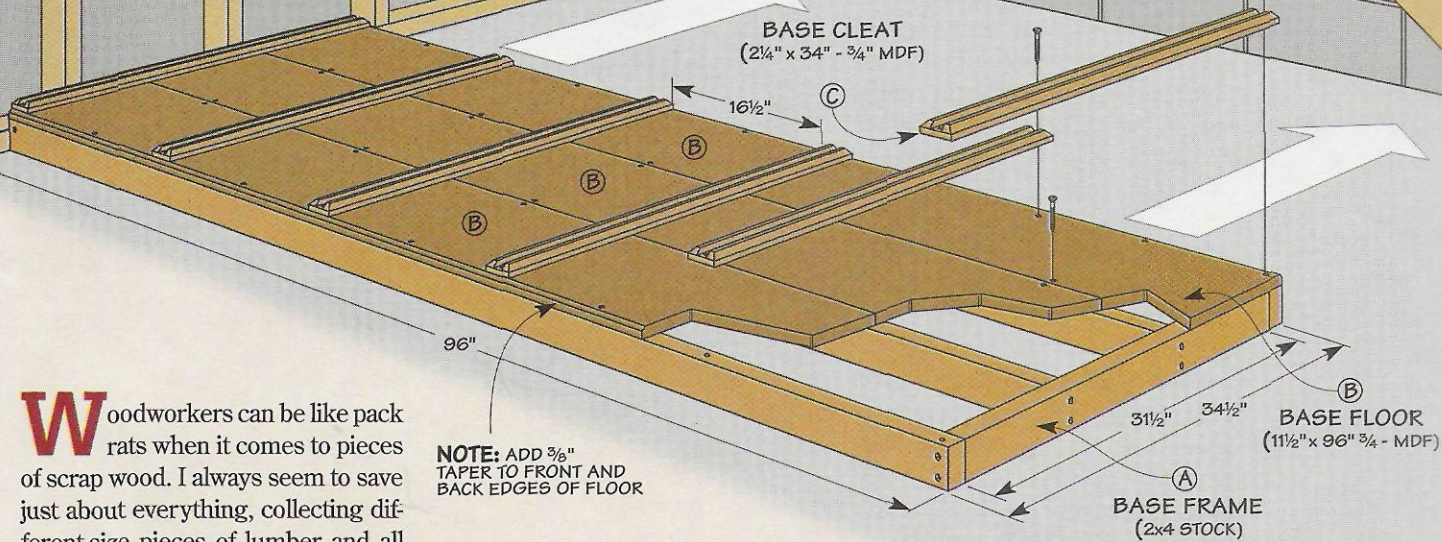
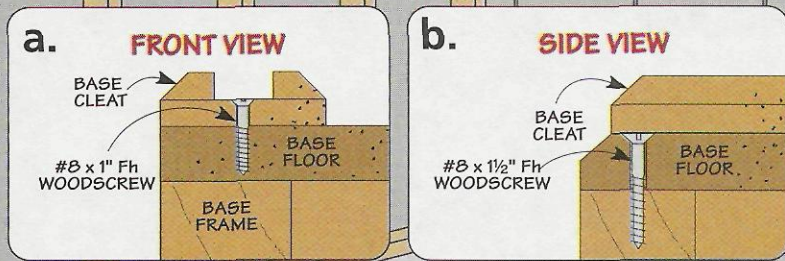

Woodworkers can be like pack rats when it comes to pieces of scrap wood. I always seem to save just about everything, collecting different-size pieces of lumber and all sizes and shapes of plywood cutoffs. The problem I always have is finding a place to store them all.

Then I discovered an often overlooked storage place right under my stairs. So, to make the most of the space, I constructed built-in shelves that fit under the stairway to keep everything in order and off the floor.

Look it Over – As you can see in the photo on the left, the dividers and shelves are raised off the floor on a sturdy 2x4 base platform. Slotted cleats hold the dividers in place and the shelves simply rest on adjustable shelf supports. The design is simple and can be easily adjusted to meet your storage needs.

Build the Base – The first thing you'll want to do is construct the solid base that supports the set of dividers and shelf components. Four 2x4's are used to build the primary base frame (A). A couple of 2x4's were added inside the base frame for support and to provide a place for the attaching the MDF floor.

Since I knew that most of my 3/4" MDF was going to be used to make the dividers and shelves, I ripped

three base floor (B) strips to size from three separate sheets of MDF. Each strip is secured using countersunk woodscrews along the edges, as shown in Figure 1 above.

Before moving on to the base cleats, you can route a 3/8" chamfer along the front and back edges of the base to give it a finished look.

Base Cleats – To hold the vertical dividers I made some MDF base cleats (C) with a centered dado routed in each cleat (Figure 2a). The dadoes were cut a little bit wider than the 3/4" MDF to allow the vertical dividers to fit easily in place.

I routed a 3/8" chamfer along both sides and ends of each cleat to remove the sharp edges (Figure 2b). To complete the base, I attached the cleats to the top of the MDF platform with countersunk woodscrews centered in the dadoes (Figure 1a).

Now, you'll want to check to see if your base sits flat and level. If it isn't level, you'll need to add some shims or levelers to the base frame. This is also a good time to secure the base frame to the wall if you think you need to keep it from shifting.

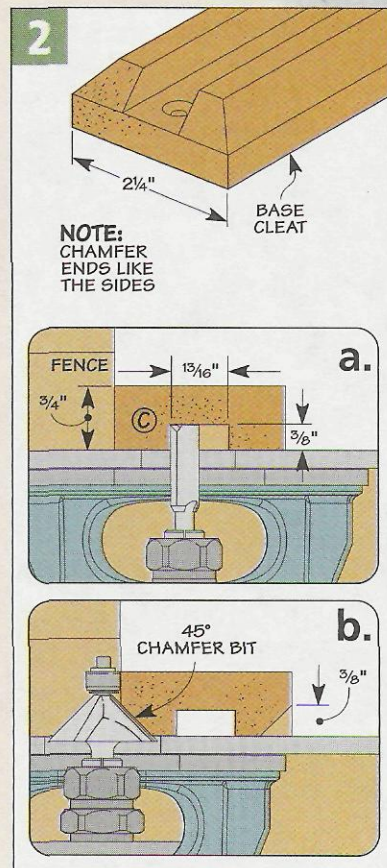

Shelf Dividers

With the base platform built and the base cleats in place, it's time to add the spaced *top rails* (D) to hold the upper ends of the vertical dividers. For this, you'll need to move to the bottom side of the stringers of your stairs.

Top Rails – In my case the stair stringers are exposed — so I was able to attach the rails to the underside of them. These rails run along the bottom of the stair stringers to capture the top of each of the vertical dividers. They need to be properly positioned to keep the vertical dividers aligned so that later the shelves will fit well.

To determine the placement of each of the rails, I used a wood straightedge and a level. Since my platform is slightly narrower than the stringers, I slipped a wood spacer between the straightedge and the outside base as shown in Figure 3. This helped me to easily line up and mark the divider locations along the edge of the stringer.

To do this I aligned the straightedge along the right edge of the dado in the base cleat and moved the level and the straightedge until

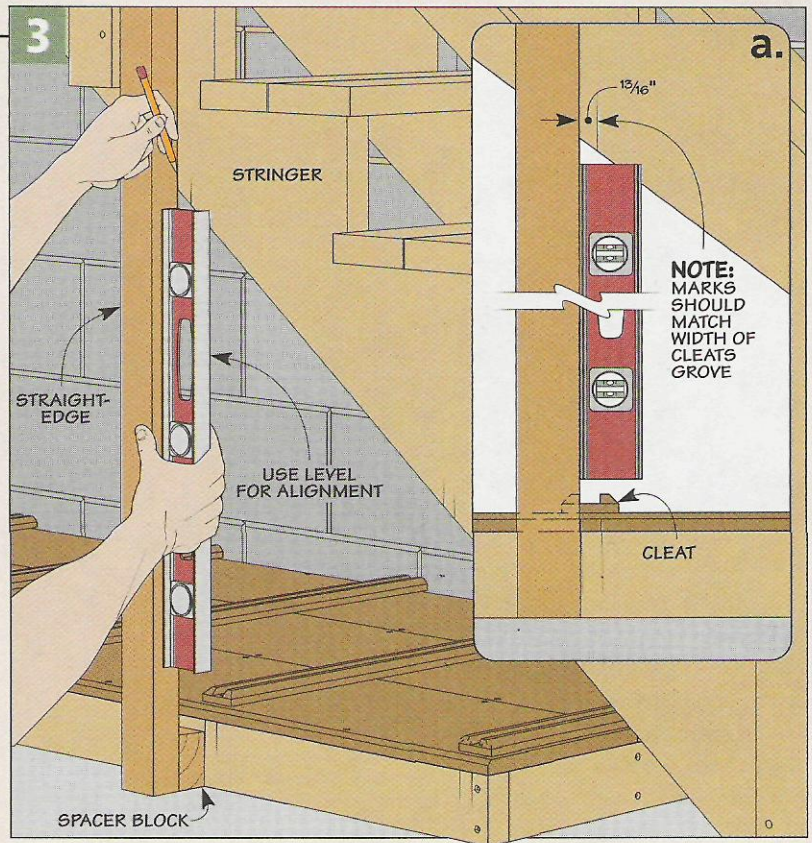

a plumb position was reached. I marked this position and then moved $\frac{13}{16}$ " to the left and made a second mark (Figures 3 and 3a). Again, slightly wider to allow the $\frac{3}{4}$ " divider to slide easily in place.

You'll need to do this for each of the base cleats to identify the position for each of the vertical dividers. Then repeat the process for the inside stringer.

Top Rail Measurements – The length and end angles of the top rails will depend on the layout of your staircase. To find the length, measure the distance between the sets of stringer marks on the outside edge of the stringer, as illustrated in Figure 4. This length will vary with the staircase.

Next, find the angle cut required for the ends of each rail. I used a bevel gauge to do this. Simply lay the body of the bevel gauge along the bottom edge of the stringer and then align the blade with one of the lines you marked on the stringer, as shown in Figure 4a.

Then use the bevel gauge to set the miter gauge on your table saw to make an end miter cut at this angle. (The angle I needed to make my end miter cut for my top rails was 53° .)

The rails can now be cut to size from ripped down 2x4 stock. You'll

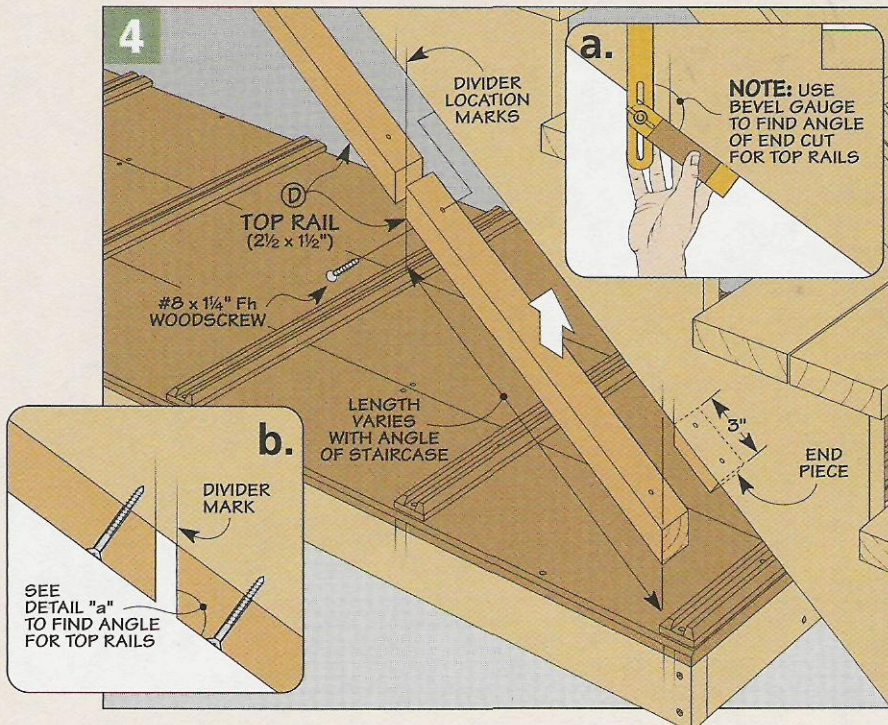

STORAGE

want to make end miter cuts to your rail measurement length at each end of the top rail 2 x 4 stock. Just use the measurements you took from the stair stringers to miter the rails to length. I cut two short end pieces and used them to capture the two outside vertical dividers at each end, as shown in Figure 4.

Before putting the vertical dividers in place, you'll want to check and see that each of the top rails line up with your stringer marks. And be sure that the outside edge of the top rail and the stringer face is flush as you screw each of the top rails into position.

Vertical Dividers – Next, cut MDF *vertical dividers* (F) to fit each of the “slots” you’ve created with the top rails and base cleats. To determine the length of each of the vertical dividers, I measured the distance from the bottom of the dado in the base cleat to $\frac{1}{8}$ " below the stringer on the low side (see Figure 5a). This will give you enough clearance to easily slide each of the vertical dividers into place.

Before you can add the shelves you'll need to drill a set of $\frac{1}{4}$ " through holes to accept the shelf supports (Figure 5b). I started with holes $6\frac{1}{2}$ " from the bottom and then added more holes every 6". But any configuration will work as long as

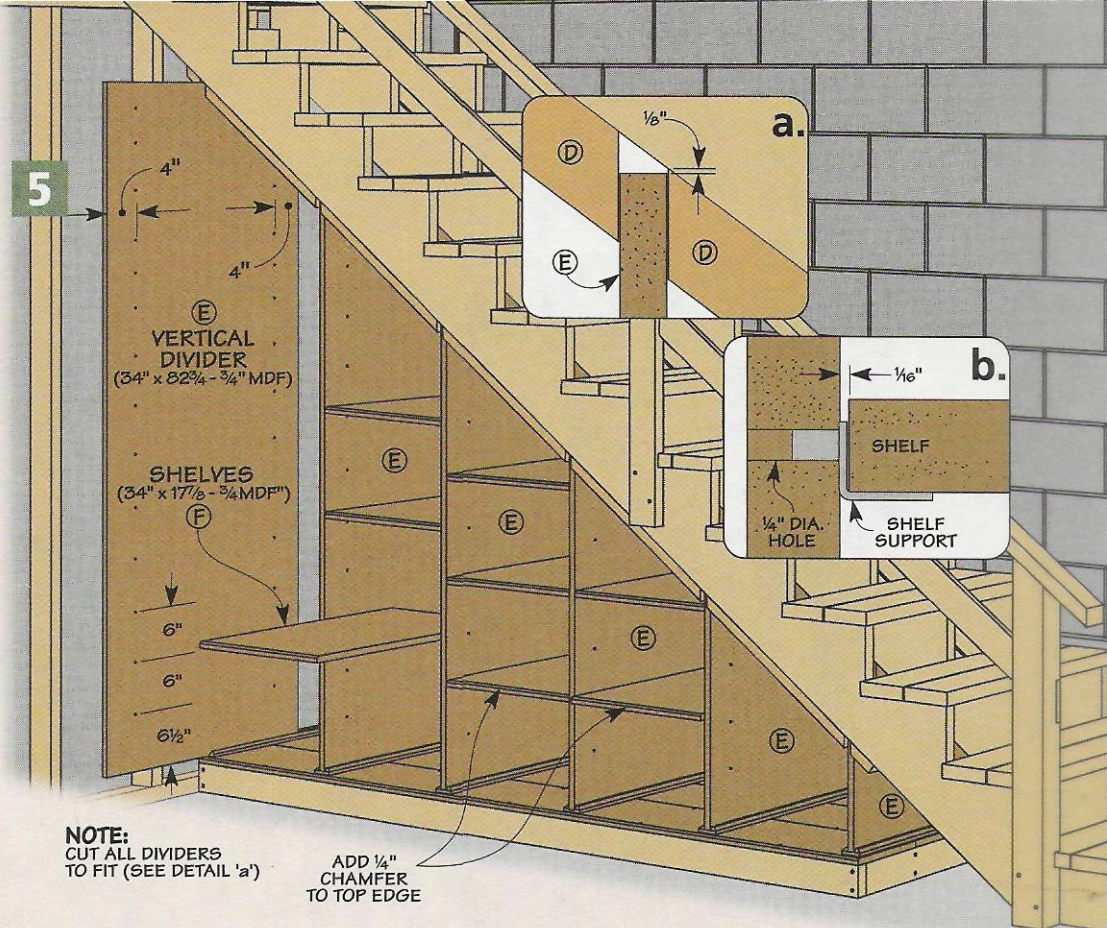

the holes line up with the opposite side so that the shelves are level.

Shelves –To finish the storage unit, I cut MDF *shelves* (D) to fit between the vertical dividers. The number of shelves you'll need will depend on how you decide to configure your storage unit. I routed a $\frac{1}{4}$ " chamfer along the front of each shelf to smooth the edges and give it a more finished look.

This under-stair storage design is adjustable and flexible. You'll find it's easy to add or remove shelves or to alter the shelf height and width as your needs change (see box below).

Now all that's left is to insert the shelf supports and slide in the shelves. It's really that easy to do.

So, if you're looking for quick and easy storage, you might just want to take a look under your feet. 🛠️

Wider Shelves

If you need some wide storage, it's an easy conversion to wider shelves. Simply remove a vertical divider and make some wider MDF shelves.

You'll need to add additional *support cleats* (H) under the shelves to prevent the shelf from sagging along this wider span.

I added a $1\frac{1}{2}$ " x $\frac{3}{4}$ " support cleat across the front and back of the shelf. Set the cleat 1" back from the front and back edges of the shelf, as shown on the right, and anchor it with screws.

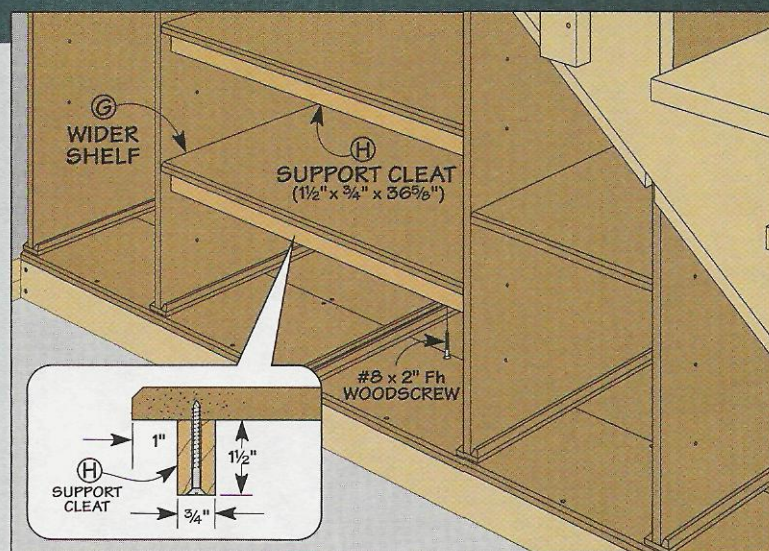

Router Bit Storage Center

Keep your router bits and accessories front and center with this easy-to-build, weekend project.

For the longest time it wasn't unusual to find router bits (and other router accessories) tucked away in every corner of my shop. Finally, after I spent more time looking for a router bit than actually using it, I knew it was time to get organized. The storage center you see at left was the solution. It keeps all my bits and accessories in one spot, protected, and right at hand.

Small Project, Big Features – The storage center has a number of handy features. For starters, there are three removable shelves for storing router bits. You can slip out a shelf and take it right where you need to work — whether that's at a router table, like you see in the photo, or across the shop at your workbench (with a hand-held router).

To ensure that you'll be able to store just about any size or shape router bit, there are two different shelf designs. The drawings on the opposite page show the hole arrangement I used. But you can make whatever combinations of shelves, holes, and patterns you need to suit the collection of router bits you have.

Finally, you don't want to lose track of all your router odds and ends, like wrenches and collets. To solve that problem, the bottom of the storage center has a hard-board lip to keep everything neatly contained.



Removable Shelves. The shelves can be customized to suit your set of router bits. And each shelf slides in and out with ease so you can take it right where you need it.

EXPLODED VIEW
OVERALL DIMENSIONS:
28"H x 16"W x 4³/₈"D

NOTE: STORAGE CENTER
MOUNTS TO WALL BY
SCREWING THROUGH BACK

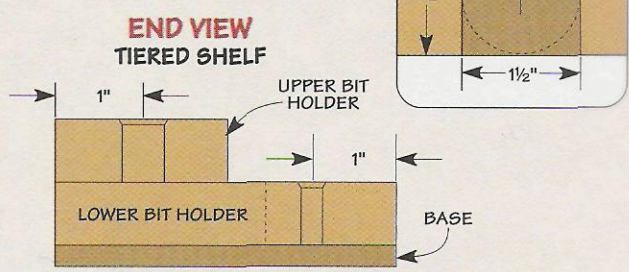
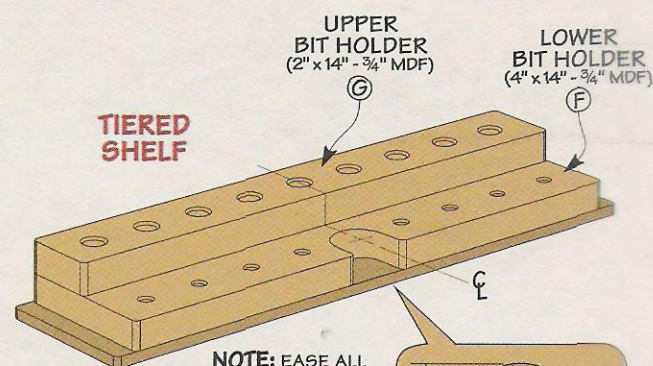
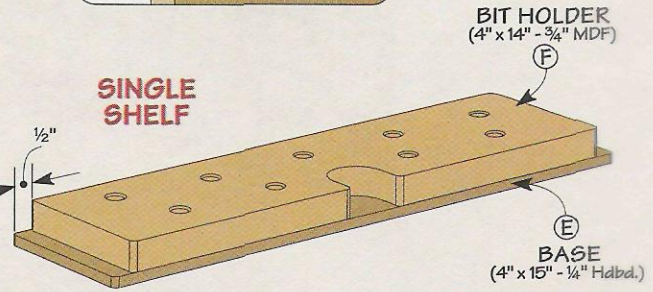
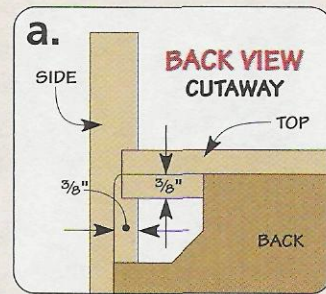
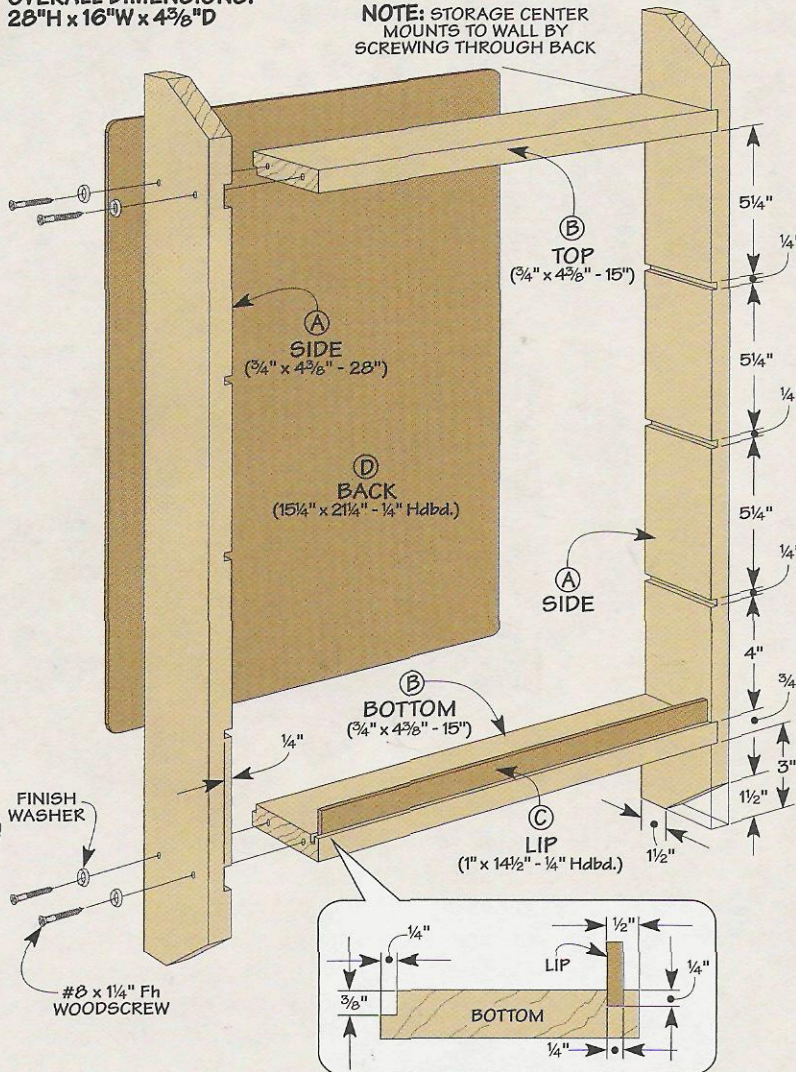

Make the Frame – I started on the storage center by making a hardwood frame. As you can see in the Exploded View, it's nothing more than a pair of *sides* (A), along with a *top* and *bottom* (B). Dadoes cut in the ends of the sides are sized to match the top and bottom. And a set of narrower dadoes (1/4") will hold the shelves made later.

Once all the dadoes are complete, you can miter the top and bottom of the sides to ease the sharp edges. Then cut a groove along the front edge of the bottom piece to accept the hardboard *lip* (C).

With the joinery complete, you can assemble the frame with glue, screws, and finish washers, making sure the assembly is square.

To keep the frame from racking, I added a 1/4" hardboard *back* (D). As you can see in detail 'a,' you'll need to rout a rabbet along the inside back edge of the frame. After cutting the back to size, round off the corners and then glue the back in place.

Shelves – At this point, you're ready to make the shelves that hold the bits. Each shelf is nothing more than a 1/4" hardboard *base* (E) with a single or double layer of MDF making up each *bit holder* (F, G).

But before you start cutting the shelves to size or drill any holes, get all your router bits together. This way, you can use the drawings above and your collection of router bits to determine the best way to customize a set of shelves to suit your needs.

Once you have the holes laid out, drill them slightly oversize (1/32"). Then chamfer the top edge so the shanks slip in and out easily (or you can simply sand the holes a bit after drilling them out). Before gluing the bit holders to the base, cut a centered notch to provide a convenient way to pull the shelf out (see lower photo on opposite page).

Fill It Up – To mount the storage center to the wall, simply screw through the back. Now all that's left to do is fill the storage center with all your router bits and accessories. 🛠️

ShopNotes

GO ON-LINE EXTRAS

To view a video on how to tie the knots shown here, go to: www.ShopNotes.com

Tying Down a Load

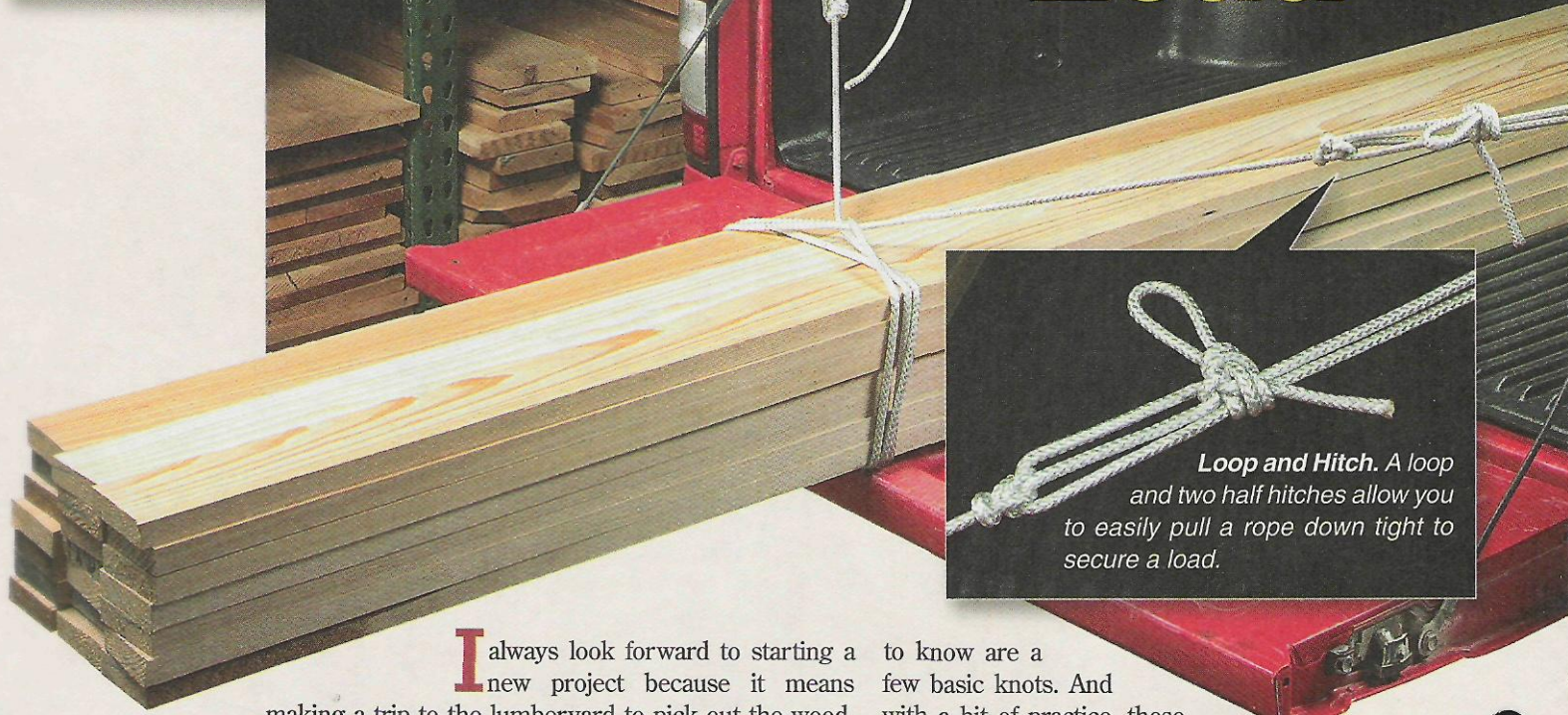

Loop and Hitch. A loop and two half hitches allow you to easily pull a rope down tight to secure a load.

I always look forward to starting a new project because it means making a trip to the lumberyard to pick out the wood. But one thing I don't enjoy is tying down my purchase for the ride home. Usually, my knot-tying efforts end up looking like a macrame project gone bad. And all the way home, I find myself nervously checking the rear-view mirror to make sure that my lumber isn't flying out of the back of my pick-up truck.

Fortunately, I've discovered that you don't need to be an Eagle Scout to tie down a load properly. All you need

to know are a few basic knots. And with a bit of practice, these will become second nature. Note:

There are literally thousands of different knots, many of which serve the same basic purpose. We've selected a few useful ones that are fairly easy to learn.

Bowline – No matter what kind of load you are tying down, the first thing you will probably need to do is tie a loop at the end of the rope to anchor it down to a hook or rack on your vehicle. One of the simplest knots to use for

this is a *bowline* (pronounced *BOH-linn*). The advantages of a bowline are that it won't slip and can be untied quickly. The drawings at left will show you how to tie this knot.

Loop & Hitch – To cinch the rope down over the load and secure the other end, start by tying a *farmer's loop* in the middle of the rope (see drawings on opposite page). Then take the loose end of the rope and wrap it around another hook on the vehicle. Now simply pass the end of the rope through the loop and pull it down snug. The loop acts like a pulley, allowing you to pull the rope down extremely tight. To hold it in place, you can tie off the rope with a *half hitch*. Together, these knots will ensure that you and your lumber arrive safely.

▼ **Start with a Bowline.** Easy to tie at the end of a line, a bowline knot won't slip and can be undone quickly.

Bowline Knot

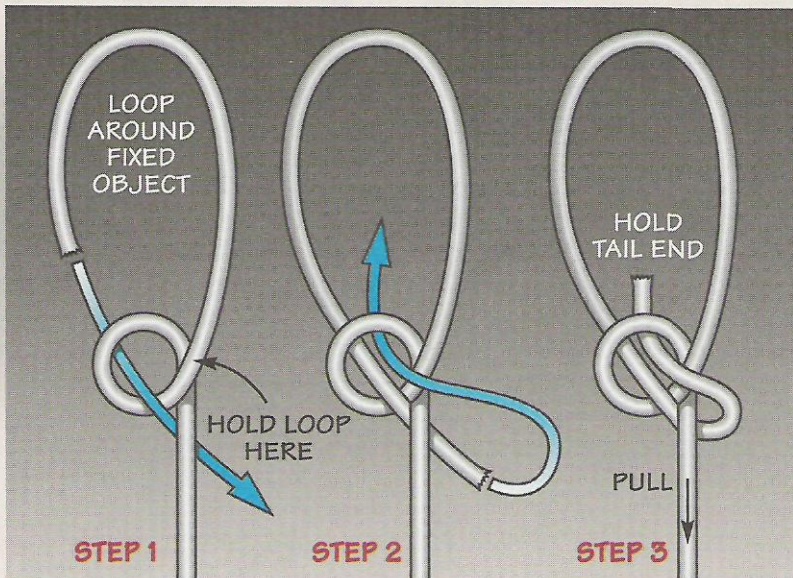

Farmer's Loop & Half Hitch

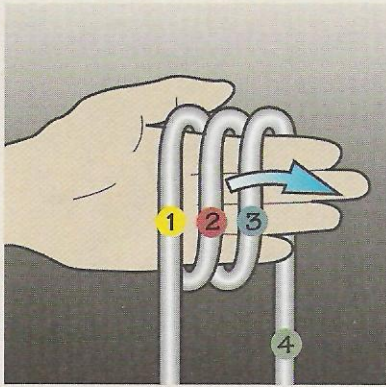

▲ **Step 1.** Loop the rope around your hand three times, then pull the middle loop (2) to the right.

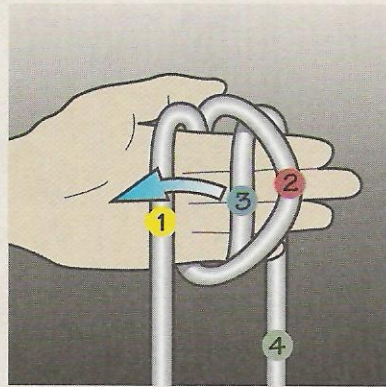

▲ **Step 2.** Next, pull the new center loop (3) to the left, crossing over loop number 1.

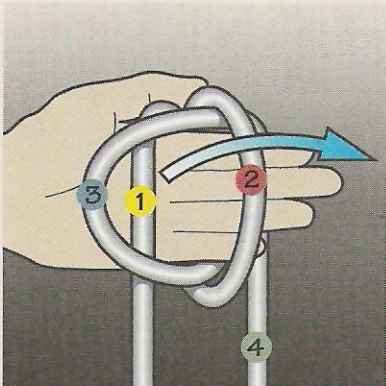

▲ **Step 3.** Now pull the new center loop (1) to the right, crossing over loop number 2.

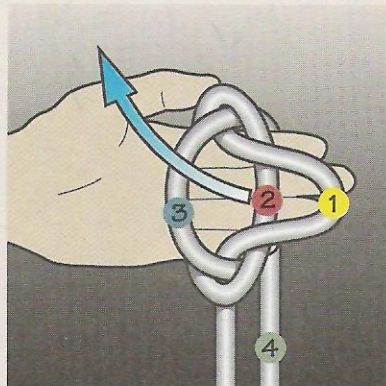

▲ **Step 4.** Finally, to create the finished loop, pull the center loop (2) out from between the other two.

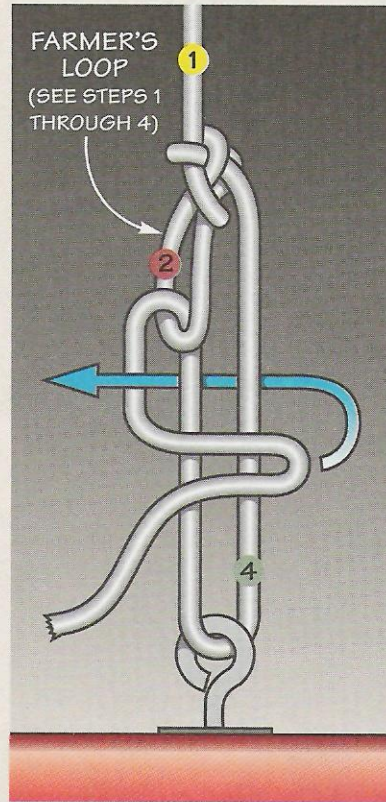

▲ **Step 5.** After passing the rope through the loop and pulling it down tight, tie off the end with a half hitch.



Rolling Hitch

If you've ever carefully tied down a load of lumber only to have it go sliding across the bed of your pickup truck the first time you make a sharp turn, you'll want to learn how to tie a *rolling hitch* (see box below). The beauty of this knot is that it

secures the load in all four directions, preventing it from shifting sideways or from front to back. It's a good knot to use if you're carrying a bundle of items, such as boards, pipes, or anything else that might slide or roll around in transit. 🚚

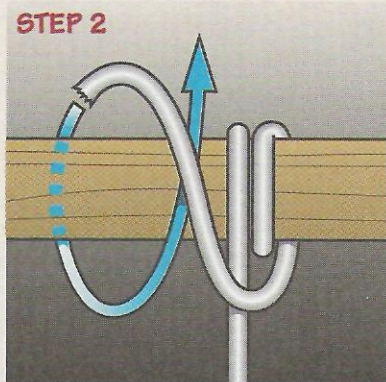
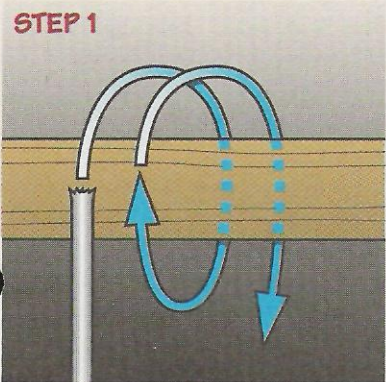

▲ **Bundle Up.** Once tightened, the rolling hitch will not slip when pulled in any direction, making it a good choice for securing a bundle.

▲ **Mechanical Advantage.** A loop tied in the middle of a rope acts like a pulley, giving you a mechanical advantage when it comes to cinching the line down over a load.

Talon Pegboard Hooks

When it comes to minor irritations, metal pegboard hooks rank right up there with mosquitoes, telemarketers, and getting a pebble stuck in your shoe. The problem with most hooks is that when you take a tool off the pegboard, the hook usually comes along with it and then drops to the floor. After this happens a few dozen times, you'll find yourself cringing every time you reach for a tool.

But awhile back, I discovered a pegboard hook that actually stays put. They're called *Talon* hooks and they just may be the greatest thing to hit your shop since the invention of sandpaper. In fact, I've replaced every pegboard hook in my shop with a *Talon* hook. They're really that good. Here's why.

Lock-On Design - *Talon* hooks work on a simple, yet ingenious, principle. On the back of each hook is a split peg that fits through a hole

in the pegboard (see left photo below). With the hook in place, all you do is push in a nylon screw on the front of the hook (see right photo below). This expands the wings of the split peg behind the pegboard, locking the hook to the pegboard. No matter how hard you tug on the hook, it won't come out. (The pegboard will break first.)

To remove a *Talon* hook, simply back out the screw. The expanding wings spring back and you can pry the hook out of the holes in the

pegboard.

Then you can reposition the hook anywhere on the pegboard and reattach it.

Strength - If you're used to metal hooks, you might be kind of skeptical the first time you pick up a *Talon* hook. (I know I was.) At first glance, they look like plastic. But they're actually made from a tough, unbreakable nylon. I've found that they can easily handle as much weight as my old metal hooks.

Styles - *Talon* hooks come in seven different styles to handle a variety of tools (see photo above and margin at left). You can purchase them in packs of all one type or as an assortment. (They range from about 60¢ to \$1.00 apiece.) For sources, see the margin on the opposite page, or visit the *Talon* website at www.talohooks.com. 



Hooks That Stay Put. Unlike conventional pegboard hooks, *Talon* hooks won't fall out of the pegboard every time you pick up a tool.

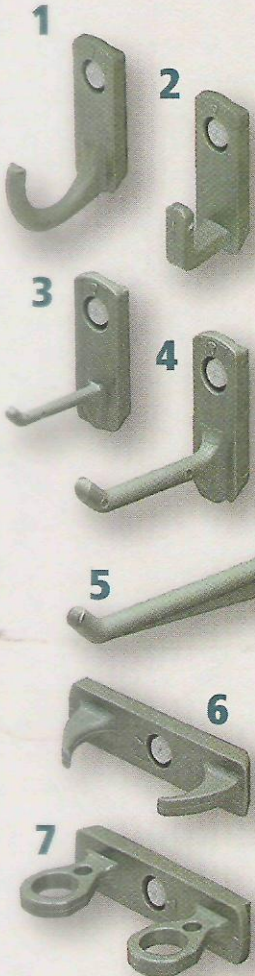

▲ **Hook Styles.** Available in seven different styles, *Talon* hooks are designed to fit 1/4" pegboard.



▲ **Insert Hook.** With the white, nylon screw backed out, slip the hook into a pair of holes in the pegboard.

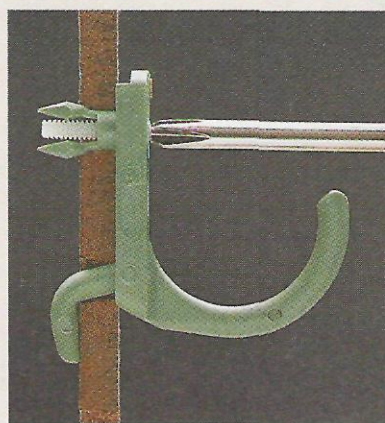

▲ **Spread Your Wings.** Push the screw in to spread the wings behind the pegboard and lock in the hook.

Sources

Similar project supplies may be ordered from the following companies:

Mobile Bases

■ Whether you're looking for a universal or dedicated base, there are quite a few manufacturers out there to help you.

Dedicated Bases – *Jet, Delta*, and other manufacturers make dedicated bases for some of their tools (and some will fit other brands of tools). But for the most complete line of dedicated bases, give

HTC a call. They have a base to match just about any tool on the market.

Universal Bases – Most woodworking catalogs feature one or two different universal bases. But you can check out the margin to find contact information for the manufacturers of the universal bases featured in the article on page 22.

Hi-Tech Table Saw Tune-Ups

■ You probably have most of what you need in your shop already to tune up your table saw (page 12). But for a “hi-tech” approach, there are a number of products available.

In-Line Industries makes a number of products for tuning up tools. Their A-Line-It Kit contains everything you'll need to check your saw down to the thousandth of an inch (0.001"). There's even an advanced kit with additional acces-

sories. *In-Line* also has other after-market add-ons for your table saw that can make it perform better — like a set of pulleys and a link belt, or the Precision Alignment and Locking System (PALS).

Finally, to get more out of your table saw blade you might want to consider the Truing Disc from *Lee Valley* or a blade stiffener from *Forrest* (800-733-7111, or on the web at forrestsawblades.com).

Fold-Away Tool Stand

■ The fold-away tool stand on page 18 requires a few bolts, knobs, and some aluminum T-Track.

I ordered a 4' T-Track Kit (24672) from *Rockler* that contained most of the hardware I needed. I had to order an extra 3' piece of

T-track and then picked up the rest of the hardware at a local home center. Note: You'll need to cut the long T-track and a couple of the flange bolts to length.

These same supplies can also be purchased from the *Woodsmith Store*.

Sliding-Door Cabinet

■ You should be able to find most of the hardware needed to build the sliding-door storage cabinet on page 6 at a local hardware store or home center. A couple of the items listed below may require a call to the manufacturer (or a check of their website) to locate a local distributor.

Hardware – To allow the doors of the cabinet to glide smoothly on the track, I used sliding screen door rollers. The ones I used were spring tension rollers made by *Prime-Line Products* (B-522). I

was able to find the rollers at a local *Ace Hardware Store* (5200662). You can also order them online at www.acehardware.com.

Storage Bins – The storage bin rack is sized to accept small *Akro-Mils* storage bins (30210). These plastic bins (or similar ones) are available from many hardware stores and home centers.

If you decide to use another brand, it's a good idea to have them in hand before you start building. This way, you'll know they'll fit, or if you have to adjust the dimensions to suit. 🛠️

- Rockler**
800-279-4441
www.rockler.com
Flange Bolts, Knobs, Mobile Bases, T-Track, Talon Pegboard Hooks
- Akro-Mils, Inc.**
800-253-2467
www.akro-mils.com
Storage Bins
- Delta**
800-223-7278
www.deltamachinery.com
Mobile Bases

- General**
514-326-1161
www.general.ca
Mobile Bases
- HTC Products, Inc.**
800-624-2027
Mobile Bases

- In-Line Industries**
800-533-6709
in-lineindustries.com
A-Line-It Kits, Link Belts & Pulleys, PALS

- Jet**
800-274-6848
www.wmhtoolgroup.com
Mobile Bases

- Lee Valley**
800-871-8158
www.leevalley.com
Truing Disc

- Prime-Line Products**
800-255-3505
prime-line-products.com
Sliding Screen Door Rollers

- Woodsmith Store**
800-835-5084
In-Line Industry Products, Knobs, Mobile Bases, Saw Blade Stiffener, T-Track, Talon Pegboard Hooks

- Woodstock International**
800-840-8420
woodstockinternational.com
Shop Fox Mobile Bases

SHOPNOTES PROJECT SUPPLIES

We now feature hardware from **ROCKLER** in many of our new project kits. To order, please use our toll-free order line, see below. It's open Monday through Friday, from 8 AM to 5 PM Central Time. Before calling, please have your VISA, MasterCard, Discover, or American Express card ready.

If you would prefer to mail in an order, please call the toll-free phone number below for more information concerning shipping charges as well as any applicable sales tax.

1-800-347-5105

ShopNotes *on the web*

- “Online Extras” - Plans, Patterns, & More
- Over 100 Woodworking Tips Online
- Visit Our Woodworking Shop Tours Gallery
- Project Plans You Can Download
- Catalog of Project Kits, Tools, Jigs, & Plans
- Forums for Woodworking, Tools, & Classifieds
- Links to Other Woodworking Sites
- Order *ShopNotes* & *Woodsmith* Back Issues

www.shopnotes.com

Online Customer Service

Click on Subscriber Services at **www.shopnotes.com**

- Access your account status
- Change your mailing or email address
- Pay your bill
- Renew your subscription
- Tell us if you've missed an issue
- Find out if your payment has been received

Scenes from the Shop

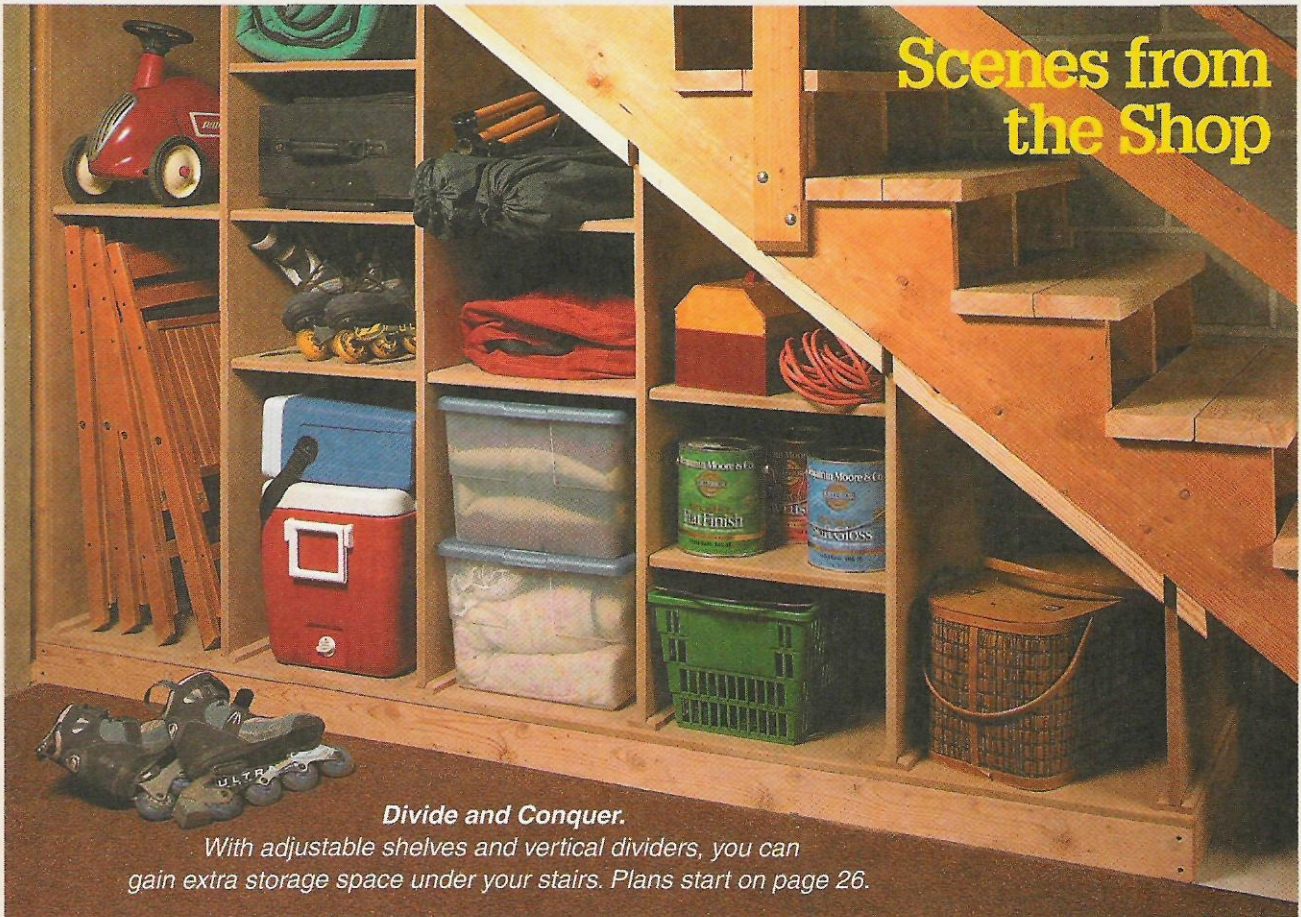

Divide and Conquer.

With adjustable shelves and vertical dividers, you can gain extra storage space under your stairs. Plans start on page 26.

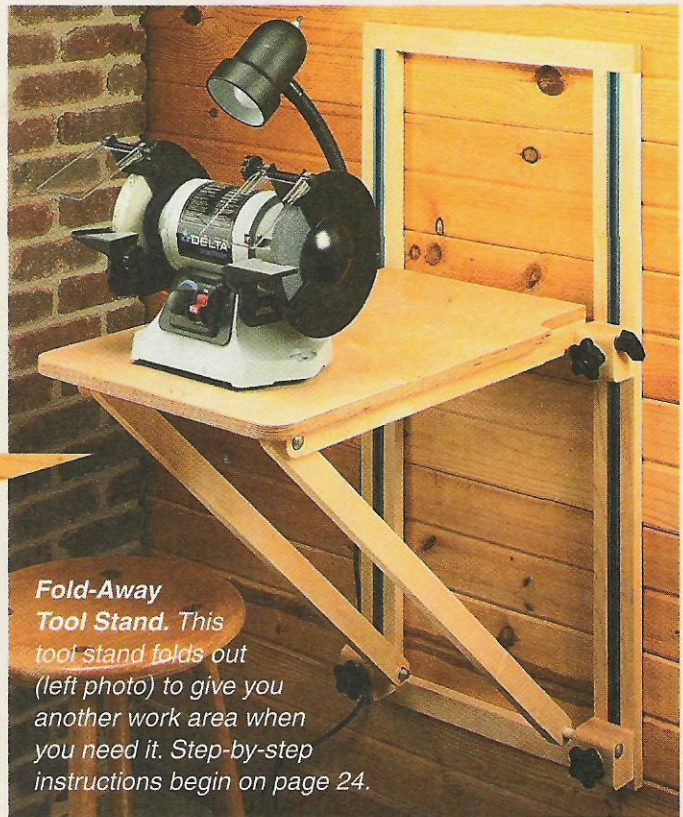

Fold-Away Tool Stand. This tool stand folds out (left photo) to give you another work area when you need it. Step-by-step instructions begin on page 24.

Pegboard Storage Cabinet

48" x 96" - 1/4" PEGBOARD

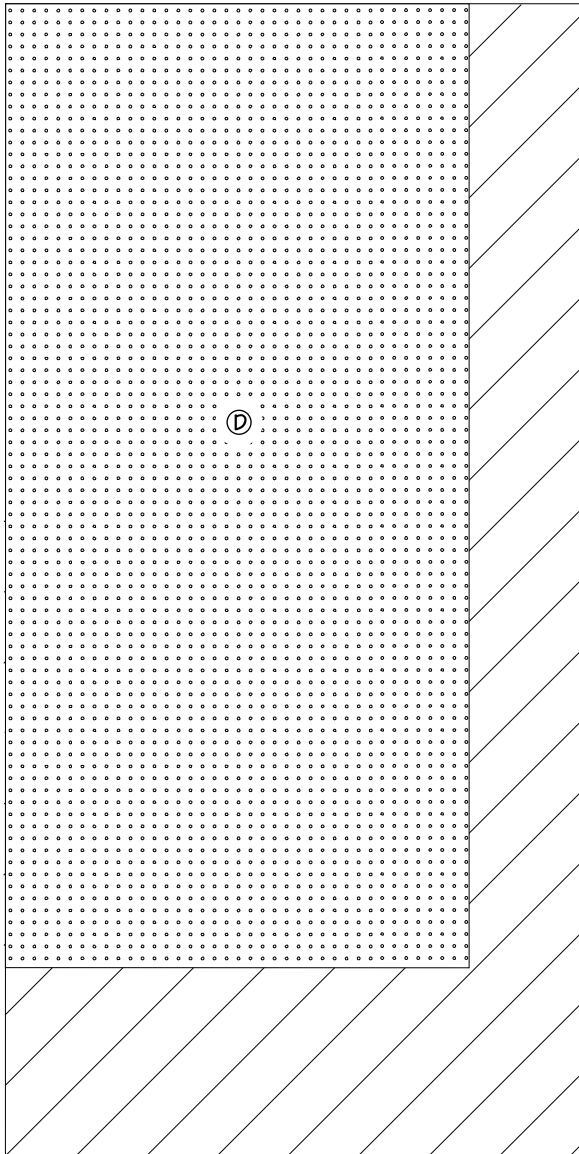

48" x 48" - 1/4" PEGBOARD

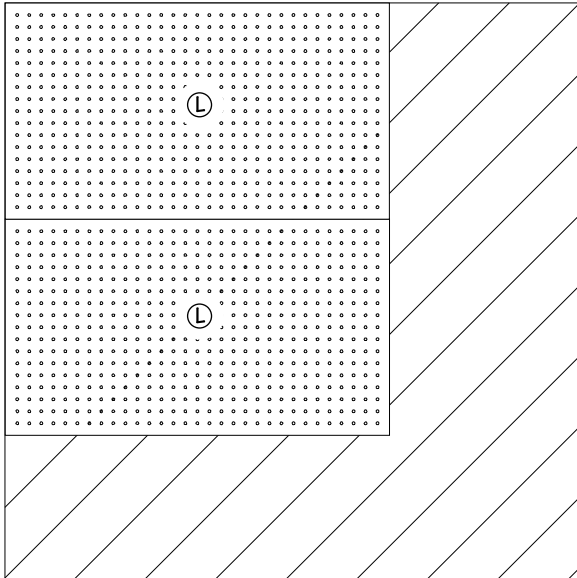

NOTE:
 CUT (16)
 BIN STOPS®
 FROM LEFTOVER
 PEGBOARD

Materials

Case

A Top/Bottom (2)	$\frac{3}{4} \times 4\frac{3}{4} - 80\frac{1}{4}$
B Sides (2)	$\frac{3}{4} \times 5\frac{1}{2} - 39\frac{7}{8}$
C Dividers (2)	$\frac{3}{4} \times 3\frac{1}{2} - 37\frac{5}{8}$
D Case Back (1)	$38\frac{5}{8} \times 80\frac{1}{4} - \frac{1}{4}$ Pegboard
E Back Cleats (2)	$\frac{3}{4} \times 3\frac{1}{2} - 80\frac{1}{4}$
F Face Frame Rails (2)	$\frac{3}{4} \times 1\frac{1}{2} - 77\frac{3}{4}$
G Face Frame Stiles (2)	$\frac{3}{4} \times 1\frac{1}{2} - 39\frac{7}{8}$
H Side Shelves (6)	$\frac{3}{4} \times 3\frac{1}{2} - 21\frac{3}{4}$
I Center Shelves (2)	$\frac{3}{4} \times 3\frac{1}{2} - 34\frac{1}{4}$

Doors

J Door Stiles (4)	$\frac{3}{4} \times 2\frac{1}{2} - 37$
K Door Rails (4)	$\frac{3}{4} \times 2\frac{3}{4} - 18$
L Door Panels (2)	$18 \times 32 - \frac{1}{4}$ Pegboard
M Side Door Stops (2)	$\frac{3}{4} \times \frac{3}{4} - 21\frac{3}{4}$
N Center Door Stop (1)	$\frac{3}{4} \times \frac{3}{4} - 34\frac{1}{4}$

Bin Rack

O Top/Bottom (2)	$\frac{3}{4} \times 5\frac{1}{2} - 79\frac{3}{4}$
P Ends (2)	$\frac{3}{4} \times 5\frac{1}{2} - 5\frac{1}{2}$
Q Dividers (15)	$\frac{3}{4} \times 5\frac{1}{2} - 4\frac{1}{2}$
R Stops (16)	$\frac{1}{2} \times 4\frac{1}{4} - \frac{1}{4}$ Pegboard
S Spacer (1)	$\frac{3}{4} \times 1 - 79\frac{1}{4}$

1" x 6" - 96" TWO BOARDS



1" x 6" - 96"



1" x 4" - 96"



1" x 4" - 96"

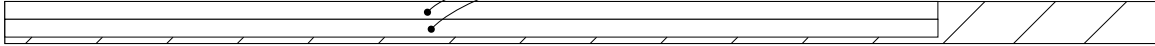

1" x 4" - 96"

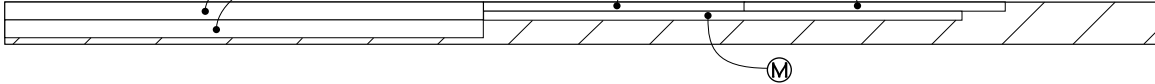

1" x 6" - 96" TWO BOARDS



1" x 6" - 96" TWO BOARDS

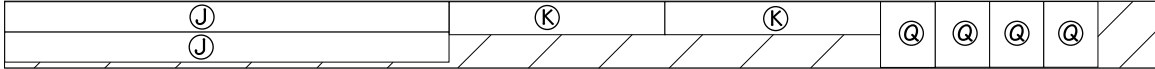

1" x 6" - 96" TWO BOARDS



1" x 4" - 96" THREE BOARDS



1" x 4" - 96"

