

10 NEW
Departments

OUR BIGGEST ISSUE EVER!

ShopNotes®

Vol. 14 Issue 79

www.ShopNotes.com

EXCLUSIVE SHOP STORAGE PROJECT SLANT-FRONT TOOL CART

Router Workshop:

Straight Story on Straight Bits

Mastering the Table Saw:

3 Can't-Miss Rabbeting Techniques

Ultimate Garage:

Foolproof Face-Lift for Your Floor

Contents

Features

storage solutions

Slant-Front Tool Cart ONLINE EXTRAS 18

Keep all your tools and supplies close at hand with this roll-around tool cart. There's even a matching tool chest you can build.

weekend workshop

Dado Blade Storage Case 30

With just a couple hours of work, you can make a handy storage case to protect your stack dado set when it's not being used.

fine tools

Brass-Body Hand Plane ONLINE EXTRAS 32

Nothing quite beats the feel of using a hand plane you've made yourself. And this brass-body model works just as good as it looks.

technique

Working with Brass 37

Working with brass doesn't have to be a challenge. Here you'll learn how to cut, shape, solder, and polish brass to a fine finish.

Departments

Readers' Tips 4

router workshop

Straight Bits 8

NEW!

We give you the straight scoop on straight bits. You'll be surprised at all there is to know.

materials & hardware

4 Favorite Fasteners 10

NEW!

Keeping a good supply of hardware on hand is a must. Here are four fasteners to keep in stock.

jigs & fixtures

Leigh Dovetail Jig 12

NEW!

The ultimate dovetail jig? Considering what you can do with this dovetail jig, you bet.

Shop Short Cuts 16

NEW!

Shop-tested tips and techniques to solve common woodworking problems.

hands-on technique

Edging with T-Molding 28

NEW!

Cover and protect the edge of plywood and MDF. T-molding makes it quick and easy.



Slant-Front Tool Cart page 18

Dado Blade Storage page 30

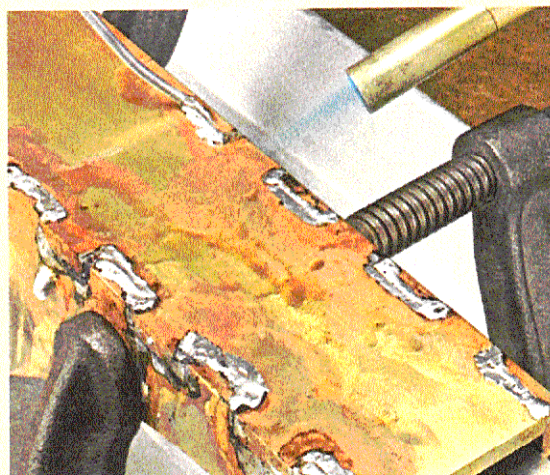

Working With Brass page 37

Brass-Body Hand Plane
page 32



Cutoffs

More. When I ask readers about how to make *ShopNotes* better, the word I usually hear is — more. Well I'm happy to say, starting with this issue, *ShopNotes* readers will be getting more than ever before.

For starters, *ShopNotes* has grown — we've added 16 more pages. But what's really exciting is what we're doing with those extra pages. If you take a look at the contents pages at left, you can see we've added several new departments.

Now with every issue you'll get more information on working with your router, mastering the table saw, setting up shop, hands-on techniques, and more. If you add it all up, you'll find 10 new departments.

Of course, we're still featuring great projects you can build for your shop. In this issue there's a slant-front tool cart, a dado blade storage case, and a brass-body hand plane.

In addition, we're offering plans for a bonus project — a brass-body block plane. These plans are currently available online at www.ShopNotes.com and they're free.

Along with the additional pages we wanted to make *ShopNotes* easier to read and use. So we've made some changes to the headlines, typefaces, and page layouts.

As you can probably tell, I'm very excited about all of these changes to *ShopNotes* and I hope you will be as well.

Terry

in the shop

Rotary Tools _____ 40

NEW!

What's new in rotary power tools? Take a peek at a few must-have accessories for your rotary tool.

setting up shop

Best Place For a Table Saw **ONLINE EXTRAS** _____ 42

NEW!

Locating your table saw is the key to efficient work. We show you the best place to put it.

mastering the table saw

3 Ways to Cut a Rabbet _____ 44

NEW!

A table saw is the perfect choice for cutting rabbets. Learn three sure-fire ways to do it right.

great gear

Space-Saving Storage _____ 46

NEW!

Here's a product that will allow you to reclaim storage space between the studs in your walls.

ultimate garage

Roll-Out Shop Flooring _____ 48

NEW!

Make your floor look new again. All you have to do is roll a "new" one in place and cut it to fit.

Q&A _____ 50

Sources _____ 51



This symbol lets you know there's more information available online at www.ShopNotes.com

Tips for Your Shop

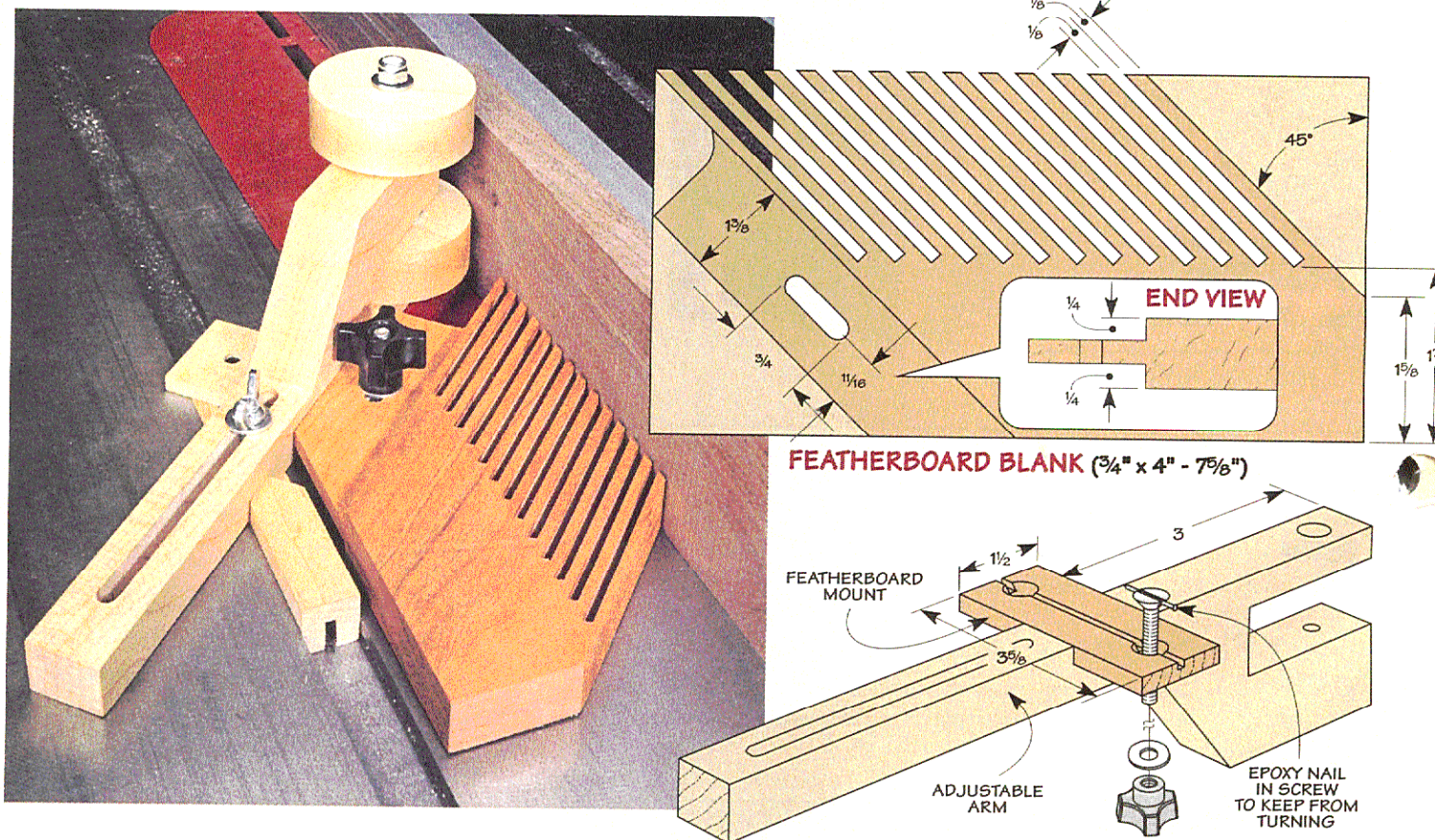

Featherboard Extension Prevents Kickback

The roller hold-down from Issue No. 76 does a good job of holding a board against the rip fence. But it doesn't do a very good job of preventing kickback. After some thought, I decided it would be easy to add a featherboard to solve this problem. It's simple to build and makes the hold-down safer to use.

I made one featherboard which I can mount on either side of the roller, depending on the situation, using a simple mounting bracket. (Or you could make two of the

featherboards and attach one to each side when necessary.)

Featherboard. Lay out and cut the featherboard and kerfs using the dimensions shown above. As you can see, this featherboard is slightly different than most. Mine has a mounting extension with a 1/4" deep rabbet cut on each side to form a tongue. A slot cut in this tongue lets me adjust the featherboard in or out.

Mounting Bracket. The bracket is just a small piece of hardwood scrap that fits in a dado cut in the

bottom edge of the hold-down's adjustable arm. I added a pair of countersunk shank holes at each end of the bracket so I could mount it on either side of the hold-down.

Then I used a hand saw to cut a shallow groove in the bottom of the bracket to hold a brad. The brad gets epoxied in the slot of a machine screw. Then the screw won't loosen once you've tightened down the featherboard with a star knob.

*Jerry Ellis
Visalia, California*

Free Tips ON THE WEB

Get more wood-working tips **free**.

Visit us on the Web at **ShopNotes.com**

Sign up to receive a free shop tip by email every week.

Help from the Kitchen

When I cut long boards on my miter saw, there are times I need help supporting the board. And there isn't always someone available to help me out. So I made an extension support using my step ladder and a rolling pin from my kitchen pantry.

I used a couple of pieces of 2x4 stock that I cut to fit into the channels of the legs of my step ladder (inset drawings below). A hole is drilled in each piece (large enough to accept the handle of

the rolling pin). I positioned the side pieces so that they would match the height of my miter saw.

To make it easy to slip the rolling pin in place, I cut a notch on one of the blocks (see drawings below). Then the rolling pin can be slipped out when not in use. This support can be adapted for use as a table saw outfeed or even an extension support for your drill press.

*Don Perkins
Modesto, California*

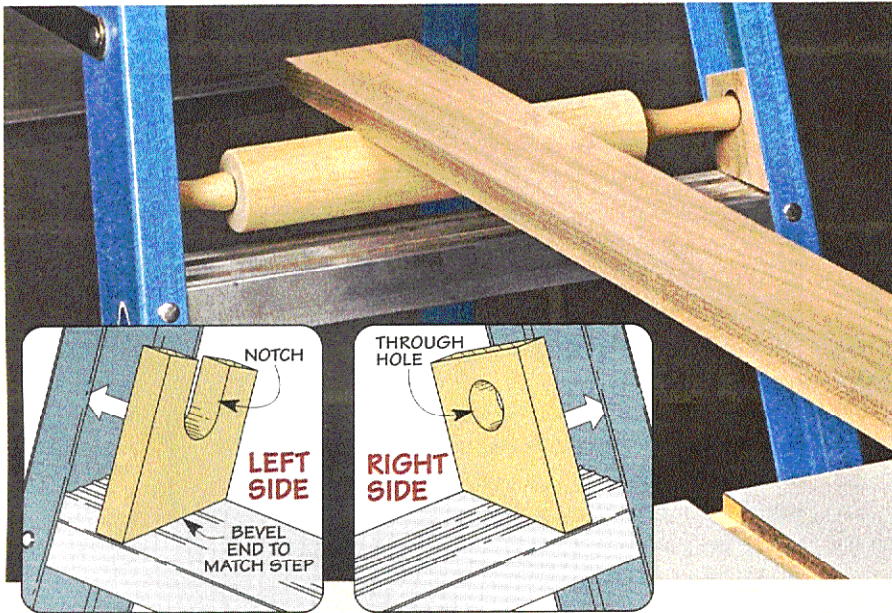

Submit Your Tips

If you have an original shop tip, we would like to hear from you and consider publishing your tip in one or more of our publications. Just write down your tip and mail it to: *ShopNotes*, Tips for Your Shop, 2200 Grand Avenue, Des Moines, Iowa 50312. Please include your name, address, and daytime phone number (in case we have any questions). If you would like, FAX it to us at 515-282-6741 or send us an email message at: shopnotes@shopnotes.com. We will pay up to \$200 if we publish your tip.

Win A Porter-Cable Router

Every woodworker needs a router. And having more than one to save set-up time in the shop is the dream of most woodworkers.

So here's your chance to make that dream a reality. Beginning next issue, if your wood-working tip or technique is selected as the featured reader's tip, you'll also win a Porter-Cable variable speed router just like the one shown here.



PUBLISHER Donald B. Peschke

EDITOR Terry J. Strohmman

SENIOR EDITORS Bryan Nelson, Vincent Ancona

ASSOCIATE EDITORS Phil Huber, Ted Raife

CONTRIBUTING EDITOR Joel Hess

ASSISTANT EDITORS Ron Johnson, Mitch Holmes

EXECUTIVE ART DIRECTOR Todd Lambirth

ART DIRECTOR Cary Christensen

SENIOR GRAPHIC DESIGNER Jamie Downing

SENIOR ILLUSTRATOR Roger Reiland

ILLUSTRATORS David Kallemyn, Peter J. Larson

CREATIVE DIRECTOR Ted Kralicek

SENIOR PROJECT DESIGNERS Ken Munkel, Kent Welsh,
Chris Fitch, Ryan Mimick

SHOP CRAFTSMEN Steve Curtis, Steve Johnson

SR. PHOTOGRAPHERS Crayola England, Dennis Kennedy

ASSOCIATE STYLE DIRECTOR Rebecca Cunningham

ELECTRONIC IMAGE SPECIALIST Allan Ruhnke

PHOTOGRAPHY INTERN Julia Adkisson

CORPORATE SERVICES: Corp. Vice Presidents: Douglas L. Hicks, Mary R. Seheve • Controller: Craig Stille • Dir. Financial Analysis: Lesia Smith • Sr. Acct.: Laura J. Thomas • Accts. Payable: Mary J. Schultz • Accts. Receivable: Margo Petrus • Prod. Dir.: George Chmielarz • IT Manager: Brian VanHeuverswyn • Electronic Pub. Dir.: Douglas M. Lidster • Sys. Admin.: Cris Schwanebeck • P.C. Maint. Tech: Robert D. Cook • New Media Mgr.: Gordon C. Galipe • Multimedia Art Dir.: Eugene Polshesca • Web Server Admin.: Carol Schoeppler • Web Content Mgr.: David Briggs • Multi-media Designer: Kara Pastour, Justin Graca • Web Prod.: Terry Walker • Research Coord.: Nicholas A. Jaeger • Prof. Dev. Dir.: Michal Sigel • Benefits Spec.: Jennifer Huisman • Hiring Spec.: Jessica Tosar • Facilities Mgr.: Kurt Johnson • Office Mgr.: Jeanne Johnson • Admin. Asst.: Brandi Hammond • Mail Room Clerk: Lou Webber • Facilities Mgr.: Kurt Johnson **CIRCULATION:** Circ. Oper. Dir.: Sandy Baum • Circ. Marketing Dir.: Wayne J. Klingbeil • Strategic Business Analyst: Kris Schlenner • Circ. Marketing Analyst: Patrick Walsh • Renewal Mgr.: Paige Rogers • Circ. Marketing Assoc.: Christine Forret • Circ. Mgr.: Stephanie Forinash • Circ. Fulfillment Mgr.: Suzanne Hejkal • Sr. Graphic Designer: Robin Friend, Randy Shebek **PRODUCTS GROUP:** Oper. Dir.: Bob Baker • Customer Service Mgr.: Jennie Eros • Warehouse Supervisor: Nancy Johnson • Buyer: Linda Jones • Asst. Buyer: Nancy Downey • Sur. Cust. Serv. Reps.: Anna Cox, April Revell, Deborah Rich, Valerie Jo Riley • Cust. Serv. Reps.: Kim Harlan, Katie Parker, Tara Benschhof • Warehouse Staff: Sylvia Carey, Kim Freault, Stephen Griffin

ShopNotes® (ISSN 1062-9606) is published bimonthly (Jan., March, May, July, Sept., Nov.) by August Home Publishing, 2200 Grand, Des Moines, IA 50312.

ShopNotes® is a registered trademark of August Home Publishing. ©Copyright 2005 by August Home Publishing. All rights reserved. Subscriptions: Single copy: \$4.95. One year subscription (6 issues), \$27.95. Canada/International add \$10 per year, U.S. funds.

Canadian Subscriptions: Canada Post Agreement Number 40038201. Send change of address information and blocks of undeliverable copies to PO Box 881, Station Main, Markham, ON L3P 8M6.

Canada BN #S4597 5473 RT
Periodicals Postage Paid at Des Moines, IA and at additional mailing offices. Postmaster: Send change of address to *ShopNotes*, P.O. Box 37103, Boone, IA 50037-2103.

Online Customer Service. www.ShopNotes.com

- Access your account
- Check a subscription payment
- Tell us if you've missed an issue
- Change your mailing or email address
- Renew your subscription
- Pay your bill

Email: shopnotes@shopnotes.com

Write to *ShopNotes*, P.O. Box 842, Des Moines, IA 50304 or call 1-800-333-5075, 8:00 am to 5:00 pm, Central Time, weekdays. Or send an email to: orders@shopnotes.com

AUGUST HOME
PUBLISHING COMPANY

Printed in U.S.A.

Cut-off Sled Hold-Down

One of the problems I've found with cut-off sleds is that as the workpieces get shorter and shorter, your fingers get closer and closer to the blade. To solve this problem I simply added a hold-down clamp to the sled, like the one you see in the photograph at right.

Since the small workpiece is secured tightly to the sled, it provides greater safety. And it will also ensure that you will be able to make a more accurate cut.

This modification can be made to almost any cut-off sled. It's especially helpful when you need to cut a number of small pieces.

To make this simple modification, just drill a $\frac{5}{16}$ " hole at one end of the sled that will accept a short piece of threaded rod. The location of the hole depends on the type of hold-down you'll be using. It just needs to be located close enough for the hold-down to secure a small workpiece firmly in place.

Next, install a $\frac{5}{16}$ " T-nut on the underside of the sled. Use your Forstner bit to make a counterbore to recess the T-nut. This will prevent the T-nut from hanging up as the sled is pushed along the table.

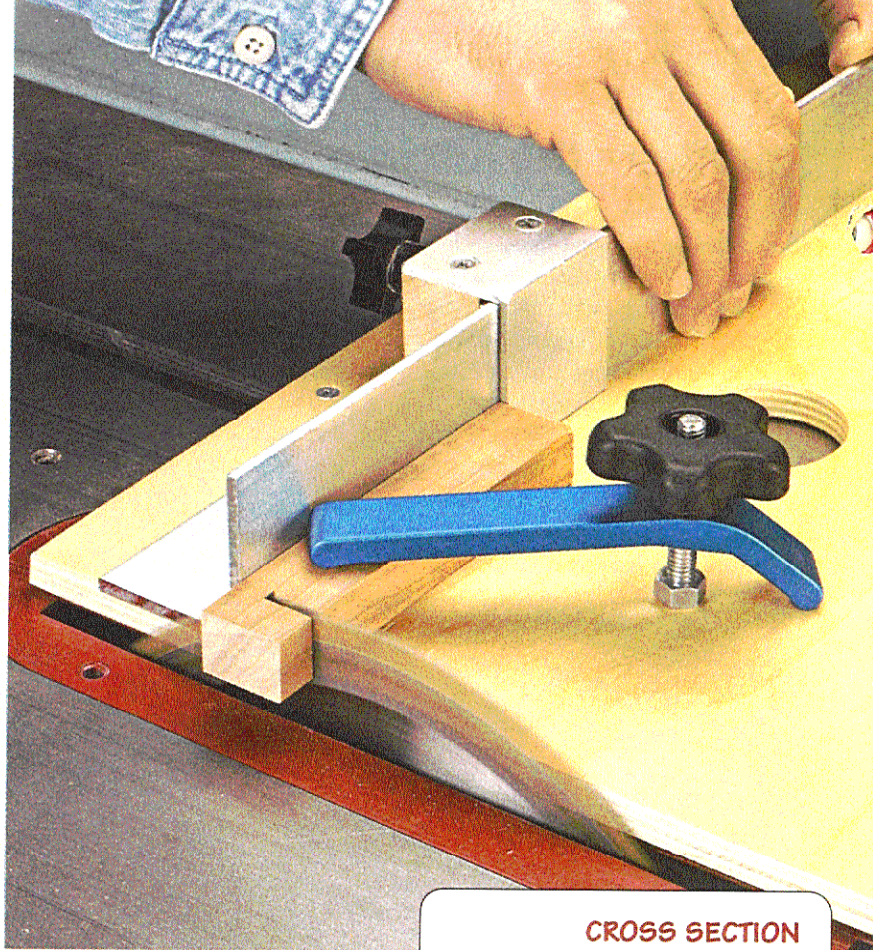

Now, all that's left is to slip a hold down over the threaded rod, add a star knob, and the modification is complete. When you need to cut larger pieces all you need to do is to remove the hold down.

*Len Urban
Rancho Mirage, California*

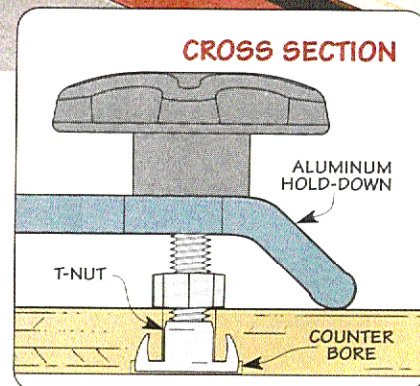

Quick Tips

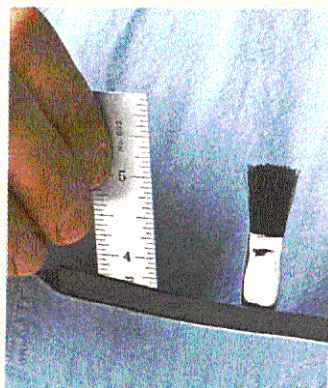

▲ **Craig Ruegsegger** of Des Moines, IA uses adhesive-backed magnetic business cards from the office supply store to prevent steel objects from falling out of his pocket. Remove the adhesive backing and slip the card inside your pocket.



▲ **Issac Coker** of Chariton, IA uses the scrap punch-out foam rubber from children's toys as pads for his pipe clamps. The dense foam is easy to cut into a shape to fit the head of your clamps. Then place it between the clamp and the workpiece.

Skate Rollers for your Steady Rest

I built the lathe steady rest from Issue No. 43 and really like how the rest adjusted itself as the workpiece was turned. To make the steady rest run smoother and to protect the workpiece even more, I modified the rest.

To do this, I replaced the ball bearings with a set of inline skate wheels, like you see in the photo below. The rest now runs even quieter. And I never need to worry about marring the wood.

Since the inline skate wheels are quite a bit larger than the ball bearings, you'll need to change the length of the rest foot to fit your particular lathe. The drawing at right will guide you in constructing the steady rest if you don't have access to the original plan.

*Guy Gerrard
Orlando, Florida*

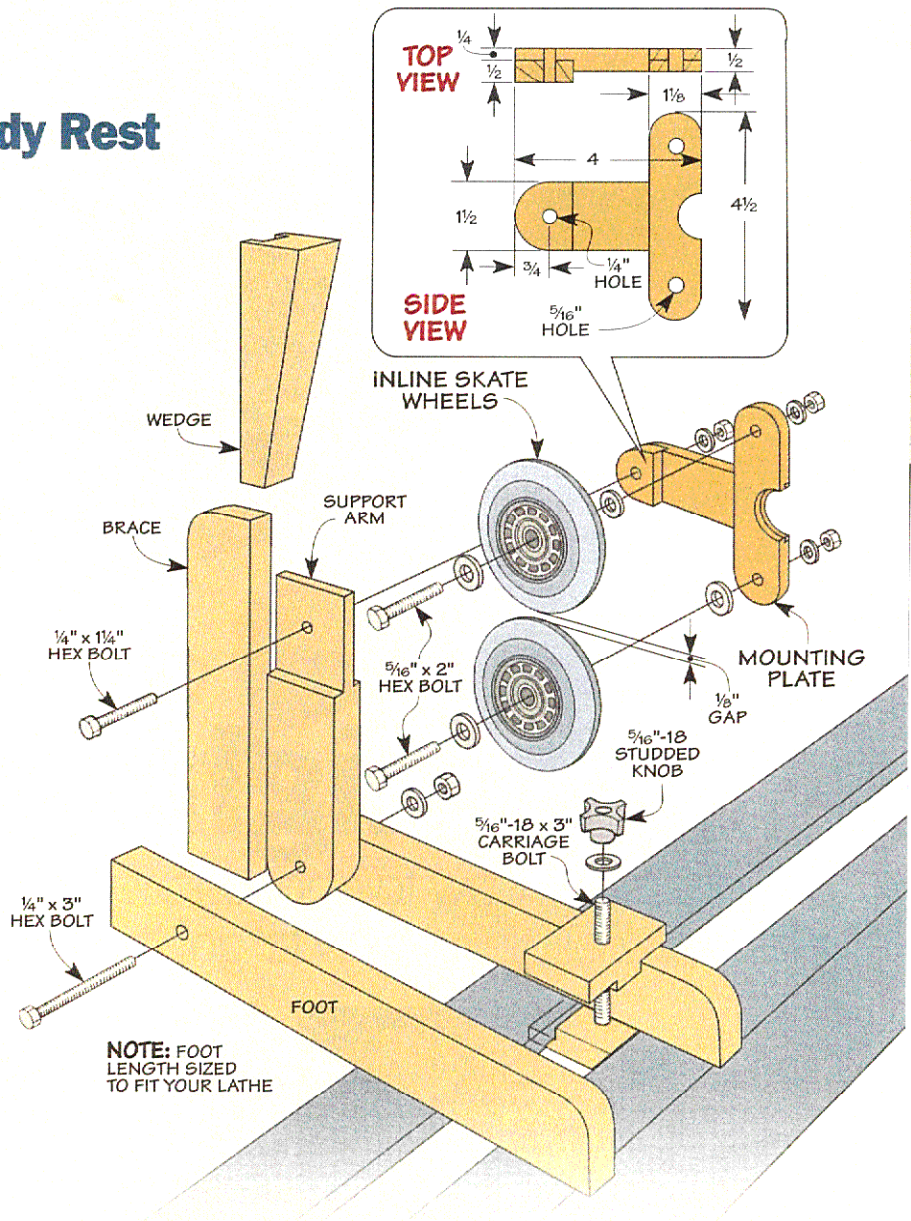
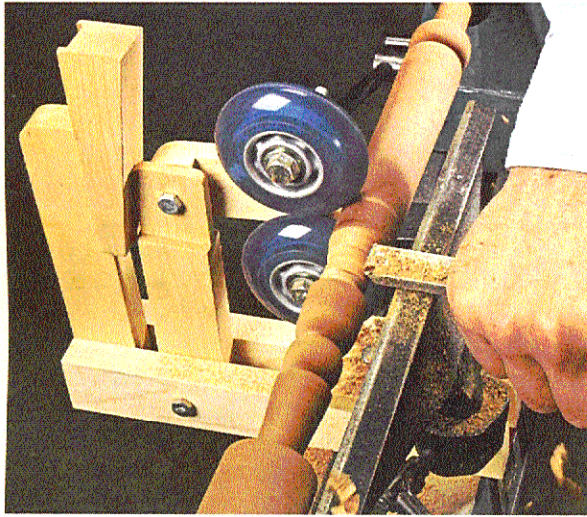

Changeable Insert Auxiliary Fence

When cutting rabbets on a table saw, I always clamp on an auxiliary fence. The problem is the clamps always seem to be in the way and the fence eventually gets all chewed up. So I made a permanent auxiliary fence with replaceable inserts (see drawing at right).

I used 3/4 inch melamine to make the fence so materials can easily slide along its smooth surface. Near the location of the saw blade, I made two 45 degree cuts to form the replaceable inserts. I left one insert solid and then cut out another insert to serve as a sacrificial fence.

Now whenever I need to change my fence set up, all I need

to do is to lift out one of the inserts and slide the other in place. One insert is always on the fence and since the other insert is small,

there is never any problem finding a place to store it.

*William Akers
Fairborn, Ohio*

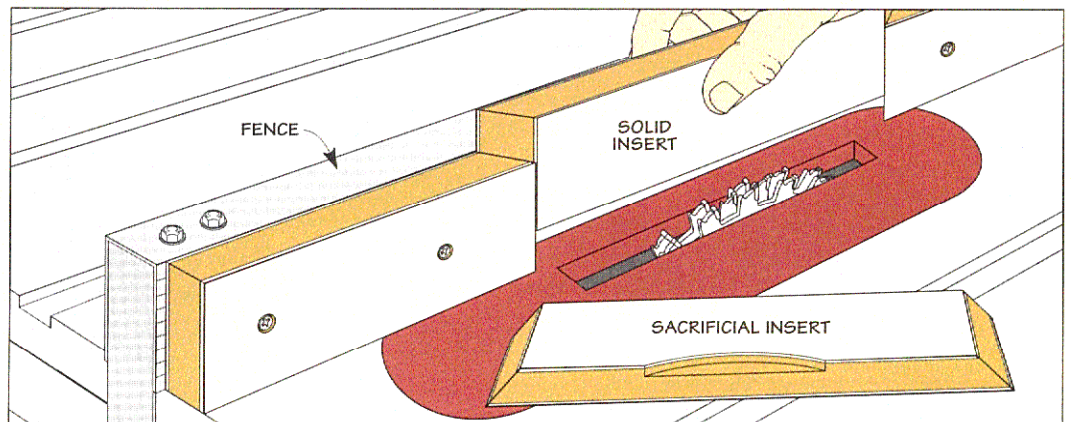

the straight story on **Straight Bits**

Learn how to choose the best of these everyday bits and how to get the best results.



▲ **All-Purpose Bit.**
A heavy-duty 1/2"-dia. straight bit (with 1/2" shank) will tackle most dado and grooving tasks.

■ A straight bit is a straight bit, right? While it may seem as if any straight bit will do the job, it pays to take a closer look and choose the bit that will give you the best results. So here are a few features and characteristics to learn about that affect the performance of the bit.

SELECTING A BIT

The first thing to consider when selecting a bit is the number of cutting edges, or flutes. Straight bits come with either one or two flutes. Single flute bits are fast-cutting, but are prone to chipout. When it comes right down to it, the quality

of cut matters more to me than speed. So I stick with bits that have two cutting edges.

Grind of the Bit. The second thing to look at on a straight bit is the type of cutting edge. For my money, I choose carbide bits over high-speed steel bits every time. Even though they cost a bit more, carbide bits stay sharp longer and cut cleaner, especially in plywood.

Speaking of carbide, bits are made with either "straight" or "radial" ground carbide edges. In straight-ground bits, the carbide behind the cutting edge is flat, as in the left drawing below. Bit makers

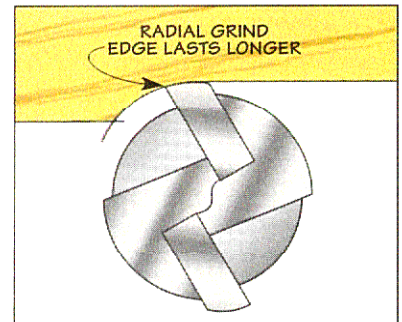
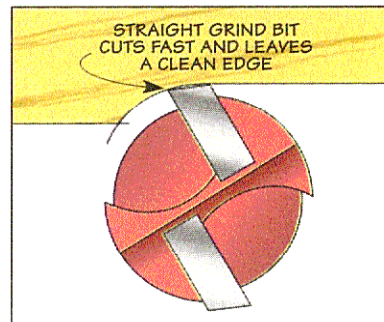

claim this type cuts faster and leaves a cleaner edge than other bits. The makers of radial-ground bits say their bits last longer.

In the end, I've found that there isn't a huge difference in speed or results. Both

types will work just fine and give you clean, crisp cuts.

Straight bits can also be specially ground for plunge cuts. To learn more, check out the box below.

Cutting Length. After checking out the number of cutting flutes and shape of the grind, it pays to think about the cutting length of the bit. Here is one case where bigger isn't always better. To get the best results, choose a bit with as short of a cutting length as possible that will still do the job.

Although it may seem like a longer bit can do more, the truth is, you rarely need the extra length. I've even had a problem being able to retract a long bit into the router enough to make a shallow cut.

There's a second reason a short bit is better than a long bit. The farther away from the motor the edge is, the more likely it is to vibrate, leaving a less than perfect edge.

Along with cutting length, you'll also need to consider shank size. A stout 1/2"-dia. shank can absorb more stress and is less likely to deflect during a cut than a 1/4" shank bit will. If your router can accommodate them, you'll find that 1/2" shank bits don't cost much more and will give you better results in the long run.

THREE BITS YOU NEED

With all these features in mind, the last decision you'll need to make is choosing the right-size bits. Although straight bits come in a wide range of cutting diameters, I've found that three sizes handle most of the work in my shop.

The most-used bit in my collection is a 1/2"-dia. bit with a cutting length of 1 1/4", as shown in the photo below and on the bottom of the opposite page. I use it mainly for routing dadoses and grooves in plywood construction. But the cutting length allows it to take on other tasks like mortises and cleaning up rough cut edges.

The second bit to have is a 1/4"-dia. bit (upper photo at right). It works great for routing the grooves for drawer bottoms. Mounted in a table, this bit can do just about anything an expensive slot cutter can.

▲ Small Bit.

Turn to an inexpensive 1/4"-dia. bit for routing slots and small grooves.

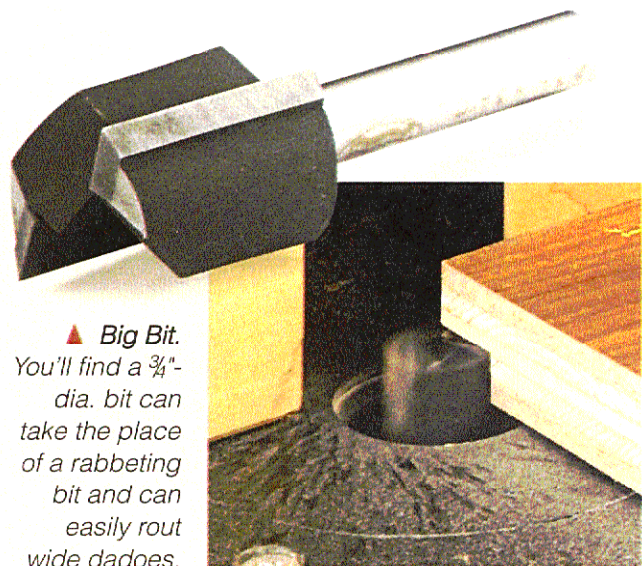

▲ Big Bit.

You'll find a 3/4"-dia. bit can take the place of a rabbeting bit and can easily rout wide dados.

The final must-have bit is a 3/4"-dia. one like you see in the photo above. Besides routing wide dadoses and grooves, this heavy-duty bit can be used with an edge guide or in the router table to take the place of a rabbeting bit. 🛠️

Look a Bit Closer: Is it Really a Plunge Bit?

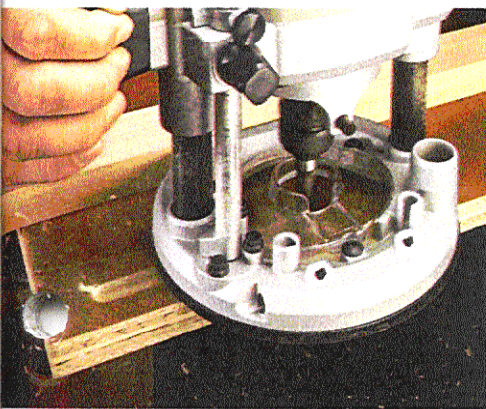

All straight bits can rout grooves, dadoses, and rabbets. But when it comes to stopped or plunge cuts, as shown in the photo at left, not all straight bits are created equal. For these jobs, you'll need to take a look at the end of the bit first.

A plunge-cutting straight bit has V-shaped cutting edge ground into the end of the bit, like you see in the photo at right. This allows the bit to cut straight in and form a hole like a drill bit, as in the photo at left.

Plunge-cutting flutes



▲ Plunge bit.

These bits can cut stopped grooves by plunging straight into a workpiece.

While most straight bits have cutting edges on the end (that's how they cut clean, flat bottoms in grooves and dadoses), there's usually a gap between the cutters, as shown in the bit on the bottom of the opposite page. This bit won't cut right at the center, which can be a problem during plunge cuts.

NEW Department!

MATERIALS & Hardware

4 of our Favorite Fasteners

Keep a few boxes of these fasteners on hand at all times and you'll be able to build almost any project.

■ When you visit your local hardware store or home improvement center, the variety of screws and fasteners available is mind-numbing. Have you ever wondered which fasteners you really need to keep on hand?

This question sparked a discussion about which fasteners are used most frequently. And which ones you wouldn't want to be without in the shop. So here's a look at

the fasteners that seem to get the most use in our shop.

SPAX SCREWS

Without a doubt, we use wood screws more than any other fastener in our shop. But not just any kind of wood screw. Whenever we need to join cabinet pieces or wood components, we reach for *Spax* screws. So what's the difference?

As you can see in the photo inset below, one of the unique features is the serrated threads at the tip. The serrated portion of the screw is slightly wider than the remaining threads. So the serrated tip cuts a pilot hole and the rest of the threads follow with minimal friction.

They're advertised to be driven without drilling pilot holes, which works well with softwoods. But I

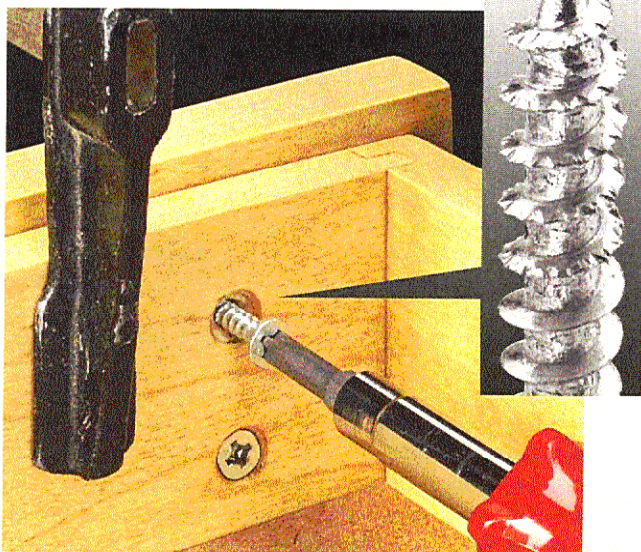

▲ *Spax Screw.* The unidrive head allows the screw to be driven with Phillips, Pozidrive or Robertson (square-drive) drivers. Serrated threads at the tip of the screw make them self-tapping and easy to drive.

Drawer Slide Mounting Screws with self-tapping threads and low-profile heads make slide installation easier



Sheet Metal Screws work well in wood, fiberglass, and metal

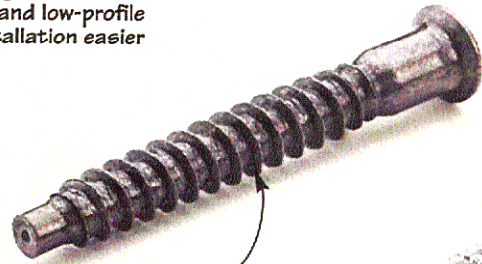

Confirmat Screw for fastening MDF and particle board

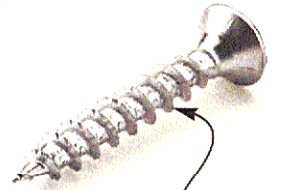

SPAX Screws drive easily in all types of materials



Sheet Metal Screw. The single lead, fine sheet metal type threads (more threads/inch) run along the entire shank of the screw. This gives them greater holding power in thin materials.

still drill pilot holes whenever I use them in hardwood materials.

In addition, they resist tearout in MDF and other particle board materials. So they're the most versatile fastener we have in the shop.

SHEET METAL SCREWS

For those times when you need a small screw with a lot of holding power, sheet metal screws meet the need. Sheet metal threads all along the shank make them hold firmly.

When you need increased holding power for installing specialty hardware, like piano hinges (see photo bottom page 10), or when you need to countersink

hinge screws a little deeper, these screws hold well. And their thread design allows them to fasten firmly in wood, fiberglass, and metal.

DRAWER SLIDE SCREWS

When it comes to installing drawer slides (photo at right), you want a small screw that's easy to drive but still has the ability to hold hardware securely in place. We install a lot of *Accuride* drawer slides, so we use *Hafele* or *Accuride* screws for this task.

You'll find these fasteners have advantages over other panhead screws. They're easy to install because the screws are self-tapping and they self-center in the mounting hole. The low profile head of these screws won't interfere with the slide function.

CONFIRMAT SCREW

Working with MDF or melamine presents a real challenge when it comes to screws. Here, the Confirmat screw works great whenever edge-to-face joining is needed for MDF or melamine workpieces. The

◀ *Confirmat Screw. When joining materials like MDF, this screw holds tight and resists pull out.*

Drawer Slide Screw. These small, self-tapping, low profile, panhead screws make it easy to install and adjust drawer slides.

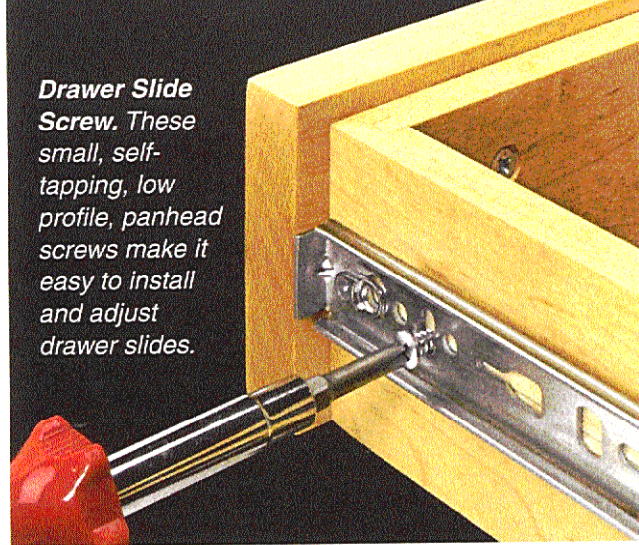

deep threads, oversized shank, and a head that is just a bit larger than the shoulder of the screw makes them unique. This screw firmly holds the pieces in place and also resists "pull out" once it's properly installed.

To install them, you'll need to drill a pilot hole through both of the workpieces. Then just insert the Confirmat screw and use an Allen wrench to drive it in, like you see in the photo on the left.

Most of these fasteners can be found in your local hardware store or home center. But a source list is provided for you on page 51.

We always try to keep a good supply on hand. This saves trips to the store and lets us spend more time working in the shop. 🛠️

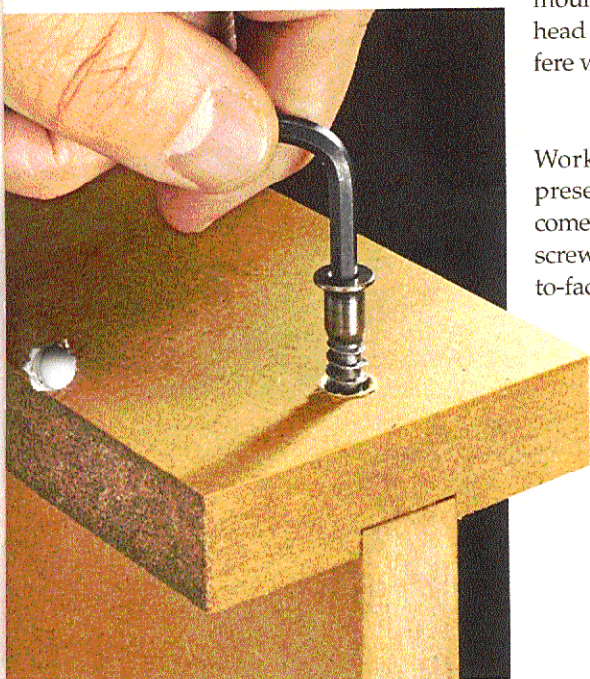

Fast and Functional: Trim Washers

I often use trim washers like those you see in the photo at the right when it comes to assembling shop projects. Despite their name, these simple washers are not just decorative. They can save you a bit of time and solve some other problems as well.

From a time standpoint, they eliminate the need for drilling a separate countersink — which can speed up assembly time. But more importantly, you don't have to worry about the countersink "blowing out" when you're putting in screws near an edge.

And finally, trim washers can prevent "overdriving" the screw. Which can be a problem in softer materials.



▲ *Trim Washer. Trim washers are a great way to strengthen an assembly, especially near the edge where you may not want to countersink the screw.*

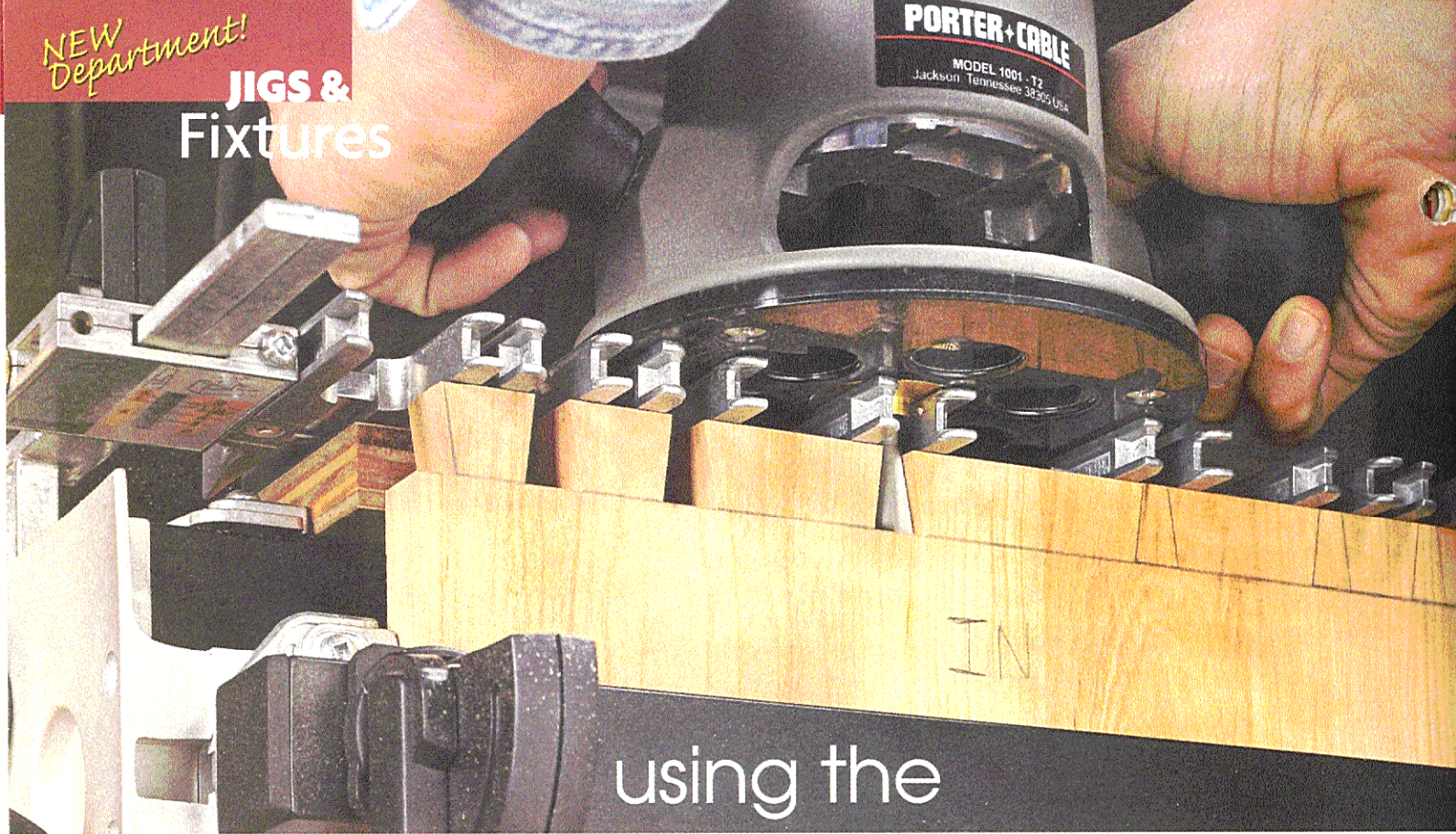

using the Leigh Dovetail Jig

When it comes to cutting dovetails of all shapes and sizes, this jig can handle it all.

■ One of the hallmarks of fine furniture is the dovetail. Whether it's through dovetails that join the wide panels of a cabinet together, or half-blind dovetails that keep a drawer front in place through repeated openings and closings, you can be sure a dovetail is a sign that a project is built to last for generations.

The biggest problem is the time it takes to cut dovetails by hand — especially when you have a lot of them to cut. To solve this problem, it's a good idea to consider using a dovetailing jig.

Now there are a lot of dovetailing jigs on the market, but if you're looking for a way to cut just about any type of dovetail arrangement you can think of (and maybe a few you haven't), then you don't need to look any further than the *Leigh D4* dovetail jig shown above.

The *Leigh* jig is arguably the most versatile dovetailing jig available (check out the *Closer Look* on the opposite page). It's strength is cutting through dovetails in a wide range of material thicknesses from $\frac{1}{8}$ " to $1\frac{1}{4}$ " and up to 24" wide.

You can even cut a host of other dovetails, like half-blind dovetails for drawers and sliding dovetails for cabinet work, using the same jig. But what I think is the best feature of the whole jig is that I can arrange and space the dovetails just about any way I'd like. I'm not limited by the fixed spacing and size of most conventional dovetail jigs and the templates available.

FINGER ASSEMBLY

To allow for this, the "template" on the *Leigh* jig is adjustable. Instead of a fixed template, there's a reversible assembly with a set of "half" fingers and a pair of dual scales, like you see in the first two margin photos on the opposite page.

One end of the half-finger controls the tail location and spacing, while the opposite end of the finger handles the pin. The dual scales help you accurately position the assembly depending on which type of dovetail joint you're cutting.

To lay out the dovetails, you loosen the fingers and slide them along the support bars to match

your dovetail layout — unlike most jigs which force you to design or adjust to match the spacing of the template. And since each finger controls both parts of the dovetail, any change you make to the tail is automatically accounted for in the pin.

Locking the fingers in place with a screwdriver (supplied with the jig) fixes the arrangement of both the tails and pins so they mate perfectly once you cut the joint. As with any jig, you'll probably need to do a little "tweaking" to get a perfect fit (more on that later). But once that's complete, you can cut joint after joint knowing each one will fit perfectly.

As I mentioned, the finger assembly is reversible. With the assembly set so the white portion of the scale is to the right (see center photo), you're set to cut through dovetails. Flipping the assembly end for end places the green part of the dual scale to the right, allowing you to cut half-blind dovetails.

Assembly. You will need to do some assembly before using the jig. The finger assembly goes together quick. All you have to do is attach the scales to each end. The stops, cams, and clamping bars go on next. Add in the time it takes to make a plywood base (for clamping the jig to a benchtop), and you'll have a couple hours invested in the entire assembly process.

Setting up the Jig. Once you have the assembly complete, you'll need to spend a little time adjusting the stops so the workpieces are positioned perfectly square once they're in the jig (bottom photo).

This doesn't take much time after making a couple squaring blanks from some scrap plywood. Plus, it gives you a chance to familiarize yourself with the jig.

Instruction Manual. The manual that comes with the jig is one of the most detailed I've ever seen. And its step-by-step sections cover the wide variety of dovetails you can cut with the Leigh jig.

Cost & Availability. As you might expect, a dovetailing jig with all this capability won't be cheap. For the bread-and-butter work of through and half-blind dovetail joints, the basic jig (with a set of bits) will run about \$400.

You can run the cost up to \$1000 by adding additional bits and accessories for cutting through mortise and tenon joints, box joints, and even some custom joints.

The Leigh jig and optional accessories are available through many woodworking stores and catalogs. To find a list of sources, turn to page 51.

Let's Start Dovetailing. But enough about the jig. Let's get started cutting a through dovetail joint. The step-by-step process begins on the next page.

Checking out the Details

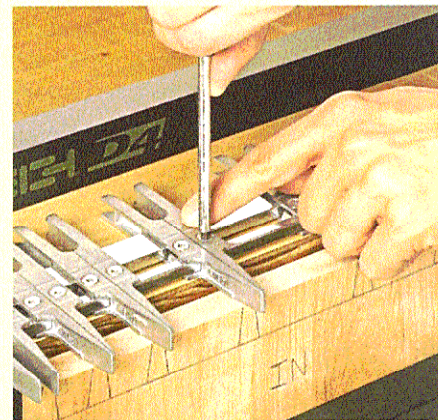

Fingers. The adjustable half fingers allow for variable spacing and sizing of both the pins and tails of a dovetail joint to suit your project design.

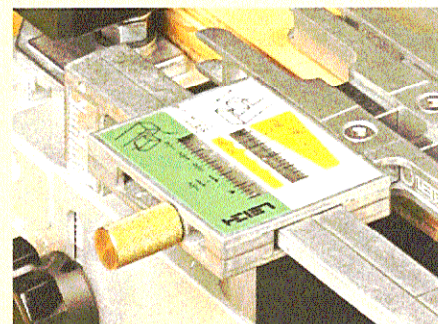

Scales. A dual scale at each end of the finger assembly helps align the fingers parallel to the workpiece and allows you to accurately "dial-in" the fit of the joint.

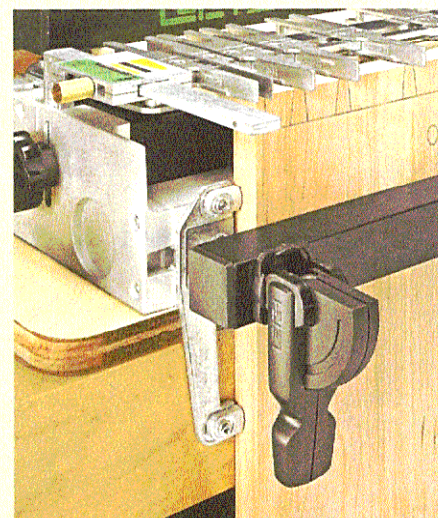

Cams & Stops. Adjustable cams lock the workpiece securely in place and adjustable stops ensure the workpiece is positioned properly.

Closer Look: Feature-Packed Jig

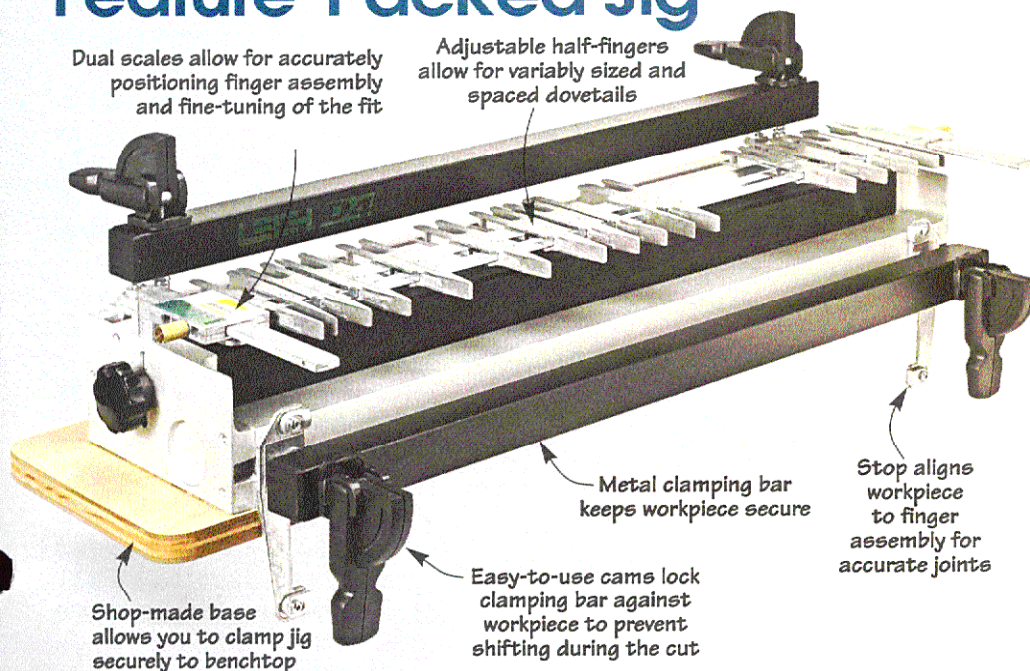

Dual scales allow for accurately positioning finger assembly and fine-tuning of the fit

Adjustable half-fingers allow for variably sized and spaced dovetails

Metal clamping bar keeps workpiece secure

Stop aligns workpiece to finger assembly for accurate joints

Shop-made base allows you to clamp jig securely to benchtop

Easy-to-use cams lock clamping bar against workpiece to prevent shifting during the cut

Perfecting the Through Dovetail

Once the *Leigh* jig is assembled, you're just about guaranteed a perfect dovetail. All you need to do at this point is follow a few key steps.

SET UP THE FINGER ASSEMBLY

To keep the finger assembly level during setup and use, you'll need to install a spacer under the upper clamp bar (photo at right).

After clamping the spacer in place, you can install the finger assembly in the "PIN" position. As I mentioned earlier, the tails are cut first. So why place the fingers in the "PIN" position? Simple, it's the only way to access the screws that allows you to adjust the fingers.

Sliding the fingers around is how you arrange the dovetail pattern. To do this, I find it works best to lay out the pattern I'd like on the end of one of my tail boards first, then I slip it into the jig. You can see part of the pattern I chose in the photo at right.

Locating the fingers is just a matter of mating a pair of fingers and centering it over the pin portion of the layout. This gives you the smallest pin possible (my preference). For larger pins, space each pair of fingers slightly apart. Note: You only need a half finger for the partial pins at each end of the board.

ROUTING THE TAILS

Now you're just about ready to cut the tails. So you'll need to flip the finger assembly around and place

it in the "TAILS" position and lock it in place.

The exact placement of the assembly isn't critical since you'll be making a cut straight through the workpiece. But it is important that the finger assembly be *parallel* to the workpiece. The scale at each end of the finger assembly will help you align it just right.

To cut the tails, you'll need to install one of the many dovetail bits available for the jig along with a bushing. The jig is supplied with a set of bits (see margin). And they work fine for through dovetails in materials $\frac{1}{2}$ " to $\frac{13}{16}$ " thick.

Cutting Depth. Once you have the bit and a bushing installed, you're ready to set the cutting depth. I drew a baseline on my tail board to match the thickness of the mating pin board. With the baseline in place, I could easily split the line with the bit to cut just a hair deep (inset photo below). This way, once you glue things up, you can sand the ends of the joint perfectly flush.

At this point, you're ready to rout the tails in *all* the tail boards. Note: The *inside* face of the tail boards

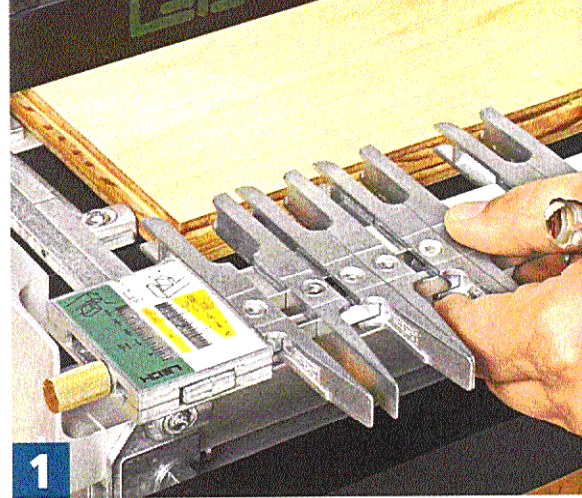

1 *The Initial Setup.* Even though you'll rout the tails to start with, the first step is to install the finger assembly in the "PIN" position.

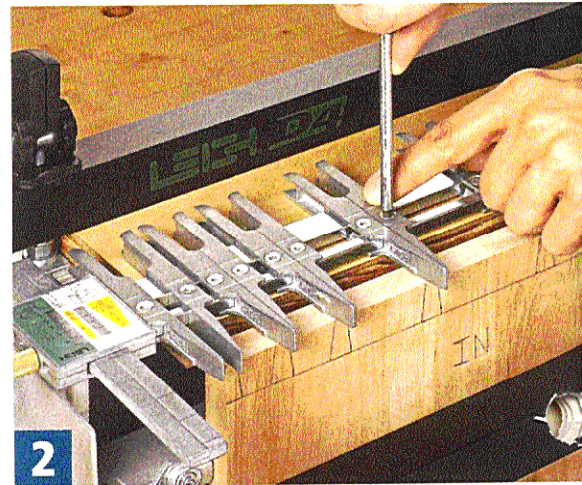

2 *Adjust the Fingers.* Using the tail board as a guide, adjust the fingers to match nearly any layout you can come up with.

should be facing out as you make the cut. As long as you have the depth of cut set correctly, you can cut the tail boards for the actual project.

Routing the tails is just a matter of guiding the bushing along the inside edges of the fingers (photo at left). Just be sure to rout down the slot formed by the rounded ends of the fingers, not the straight ones.

ROUTING THE PINS

With the tails routed, you have half the joint complete. To rout the pins, you'll need to turn the finger assembly over so it's back in the

Routing the Tails. After setting the bit to "split" the baseline in half (inset photo), rout the tails by guiding the router bushing into the slots to remove the waste.



▲ Bits by the Pair. Through dovetails require a pair of bits — a dovetail bit for the tails, and a straight bit for routing the pins.

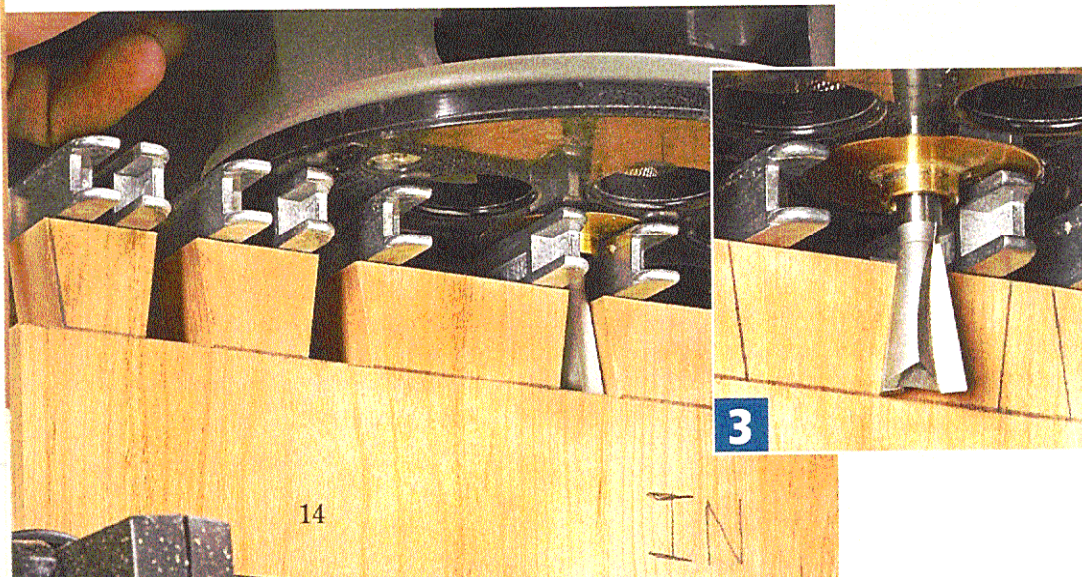

“PINS” position, without making any change to the position of the fingers. And here’s where the scale setting will really come into play.

Since the finger assembly guides the bushing (and bit) along the angled fingers, how far in (or out) the assembly is changes the fit of the joint. So you’ll need to make some test cuts in some scrap to fine tune the fit (the same thickness as your pin boards).

It’s best to set the finger assembly so the pins start off too big. Then you can slide the finger assembly in and shave a little off each pin until the fit is just right.



The pins are cut with the straight bit. So after installing it in place of the dovetail bit, you’ll need to adjust the depth of cut to match the thickness of the tail boards. Here again, I like to set the cutting depth just a hair deep.

Once that’s complete, you can rout out the waste between the pins. Note: The *outside* face of the pin board should be facing out.

TESTING THE FIT

Completing the pins allows you to test fit the joint. But as you may recall, the finger assembly was set to make the pins a little oversized to start with.

This means the two halves of the joint probably won’t fit together, like you see in the photo at left.

If you find the joint is too tight or won’t fit at all, simply slide the finger assembly away from you a little and lock it in place. Then

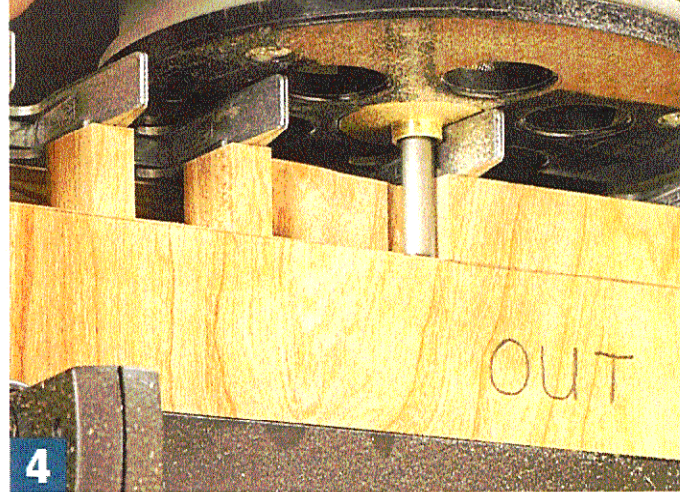

Routing the Pins. To rout the pins, flip the finger assembly around and set the cutting depth of the straight bit. Rout the pin board with the outside face facing out.

reinstall the same board and “shave” the pins slightly with the assembly in the new position.

You’ll need to repeat this process until the joint slides together. If the fit is too loose, just slide the finger assembly towards you slightly and try again with a new pin board (or cut the end off the old one).

Once you have the fit the way you’d like, you can rout the pins in all the pin boards — and then you’re ready to assemble your project. 🛠️

Test the Fit. The goal is to adjust the finger assembly to rout the pins so they just slide into the tail board with firm pressure. Once you’re there, you can rout all the pin boards.

Expand the Possibilities: Additional Joints with the Leigh

You can do a lot more with the *Leigh* jig than cut through dovetails. A couple common dovetail joints you can handle easily are the half-blind and sliding dovetails shown at right.

Half-Blind. The finger assembly on the *Leigh* makes quick work of cutting variably sized and spaced half-blind dovetails. You can design a drawer any size you’d like, instead of having to “fit” it to the fixed templates on most other dovetail jigs.

Sliding. Another handy joint you can cut with the *Leigh* jig is the sliding dovetail. For that, the finger assembly and a guide bar (supplied with the jig) guide the router as you cut each half of the joint.

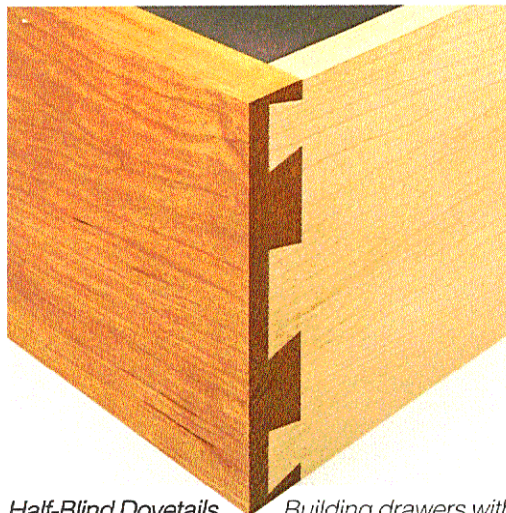

Half-Blind Dovetails. Building drawers with half-blind dovetails is a snap — even with the variable size and spacing shown above.



Sliding Dovetails. The sliding dovetail shown above is the perfect way to join shelves and partitions together securely in any project.

SHOP Short Cuts

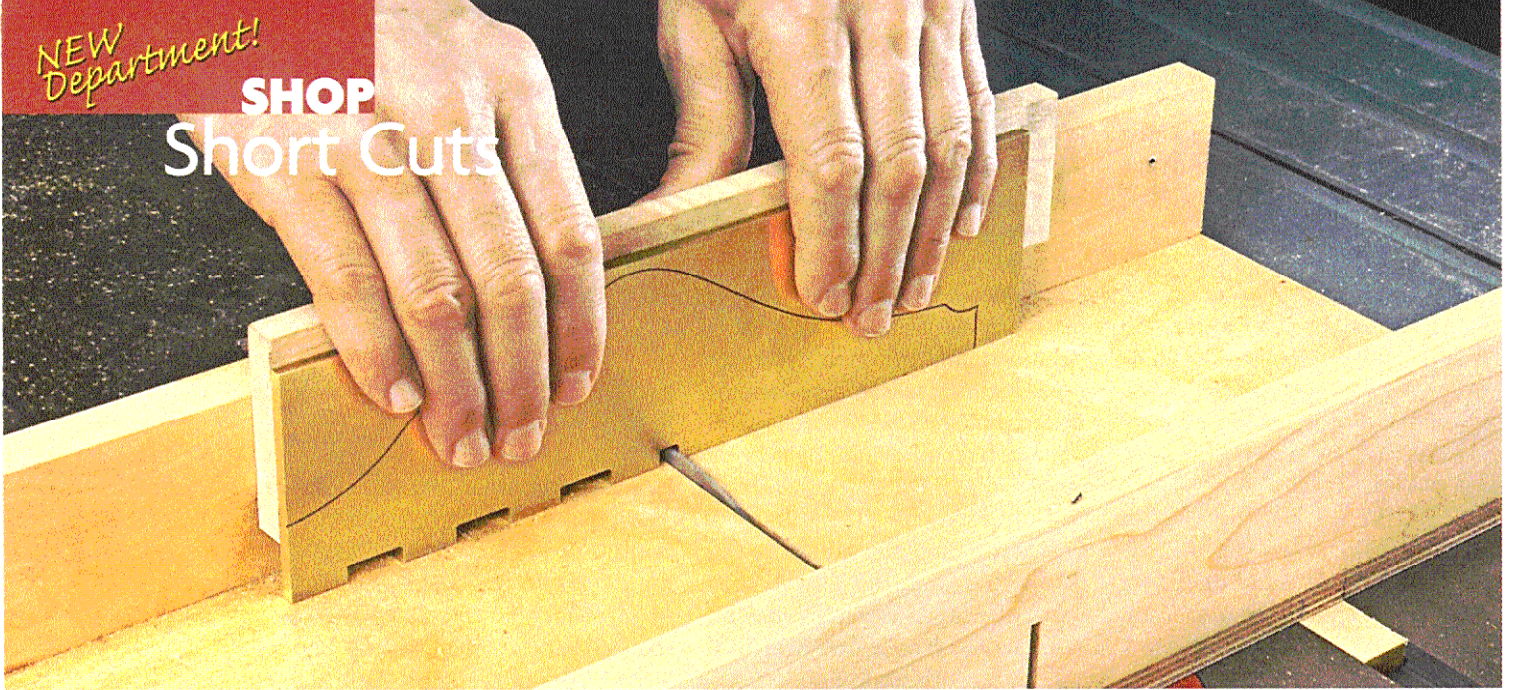

Box Joint Jig

One of the standout features on the brass-body plane are the box joints that connect the sides and sole. While you could hand cut and file this detail, I came up with a more accurate method using a table saw jig and metal-cutting saw blade.

Building the Sled. The jig consists of two parts — a sled and a template, as in the drawing below. An

aluminum key glued in a kerf in the sled guides the template.

Template. The second part of the jig is the hardwood template. To make it, I used a dado blade to cut evenly spaced notches along one edge, as you can see in the drawing below. For the plane parts to fit snugly, you'll want to take extra care in laying out and cutting the notches in the template.

Using the Jig. To cut the box joints, I taped the template to a brass blank with carpet tape. For cutting the plane sides, the end of the blank and the end of the template should be flush. Note: the template sits above the bottom edge of the brass blank by $\frac{3}{4}$ " as in the drawing at left.

Start by raising the blade $\frac{3}{16}$ " above the sled. Then place the workpiece and template against the rear fence with the first notch in the template over the key and make a pass. Then slide the workpiece over a bit and make a second cut. Continue nibbling away until the key touches the end of the notch in the template. Then lift the template and blank and slide it over to cut the next notch.

After cutting the sides, you can move on to the sole. When cutting the sole, align the end of the blank with the start of the first notch, as you can see in the drawing at left. Finally, don't worry if you notice the fingers protrude a little after assembling the plane body. They'll be sanded flush after soldering.

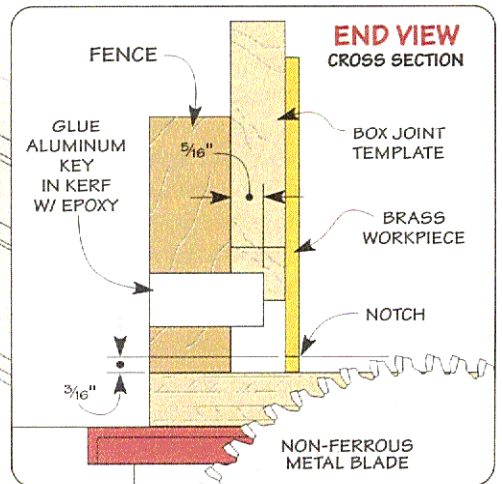
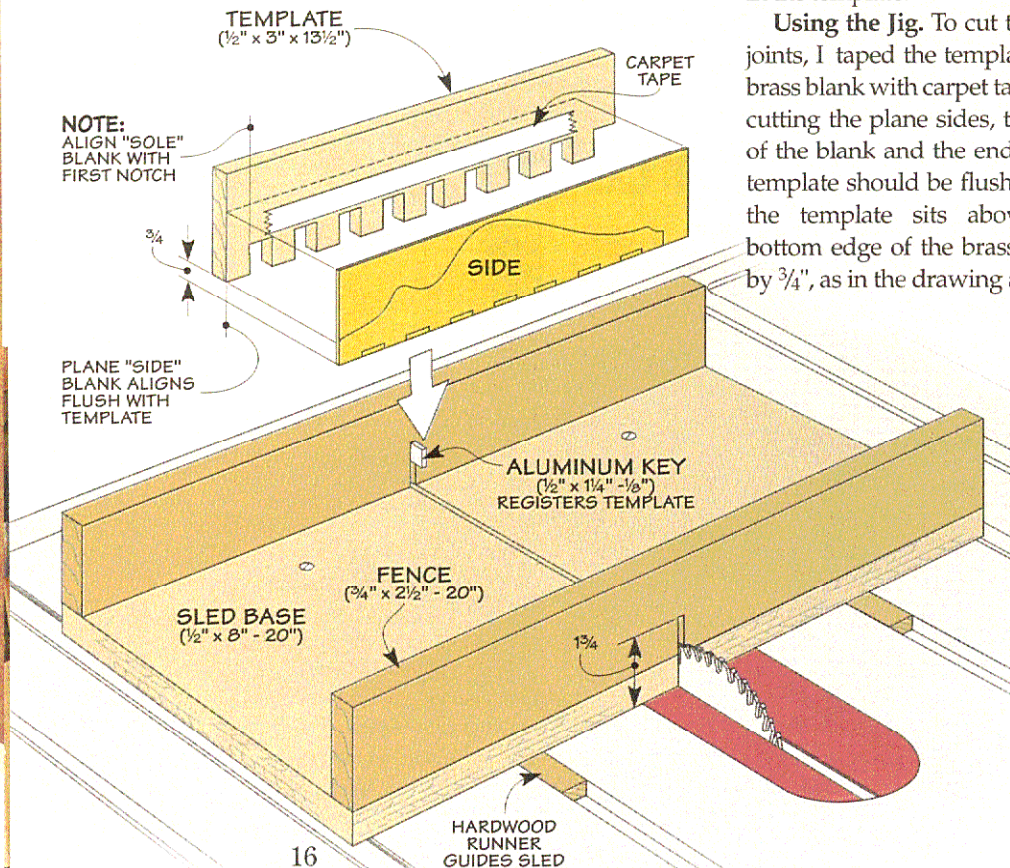

Angled Clamping Block

Attaching hardwood edging to a plywood panel is always a little tricky. The problem is keeping the edging in place long enough for the glue to dry — especially on angled parts like the slant-front tool cart shown on page 18.

I've tried a variety of techniques for holding the edging in place — from masking tape to wedges and C-clamps. The problem is they just don't provide enough pressure for a tight, even joint line.

One Piece at a Time. To solve this problem, I've come up with a different technique. Instead of trying to glue all the edging on at once, I like to glue one piece on at a time with bar clamps. Although it takes longer, you avoid a tangle of clamps or having the edging slip out of place. Then once the glue

sets up, you can move on to the next piece, cutting it to fit, and concentrating on getting a tight joint line with the plywood.

Clamping Block. When attaching the edging to the angled corner of the tool cart, I needed a way to hold the clamps square to the edging without slipping. To do this, I made a clamping block (drawing at right).

The block is a sandwich made up of three layers of plywood. A pair of angled notches in the top of the block hold clamp heads at the correct angle (photo below). The middle layer is cut from a leftover from the sides and is a bit narrower than the outer layers. This allows the block to slip over the plywood panel like a saddle and stay firmly in place. After cutting and assembling the block, I cut the notches on the band saw,

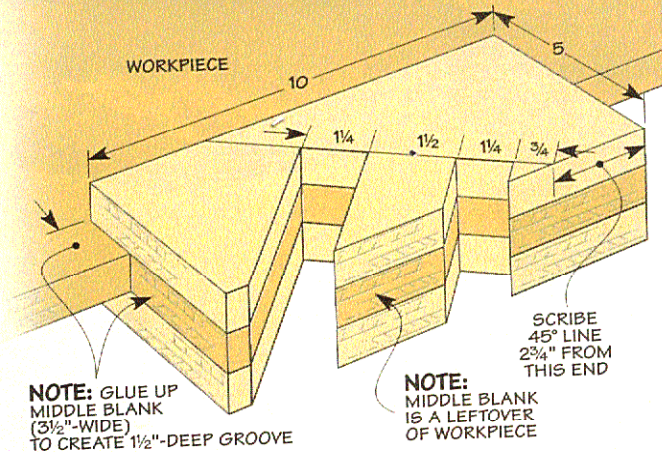

NOTE: GLUE UP MIDDLE BLANK (3 1/2"-WIDE) TO CREATE 1/2"-DEEP GROOVE

NOTE: SCRIBE 45° LINE 2 3/4" FROM THIS END
MIDDLE BLANK IS A LEFTOVER OF WORKPIECE

keeping the notches square to the angled edge of the plywood panel.

Attaching the Block. To glue the edging on, start by slipping the clamping block over the opposite edge of the panel and clamping it in place (photo below). Then, fit and glue the edging to the face and slip the clamp heads in the block and tighten them up. 🛠️

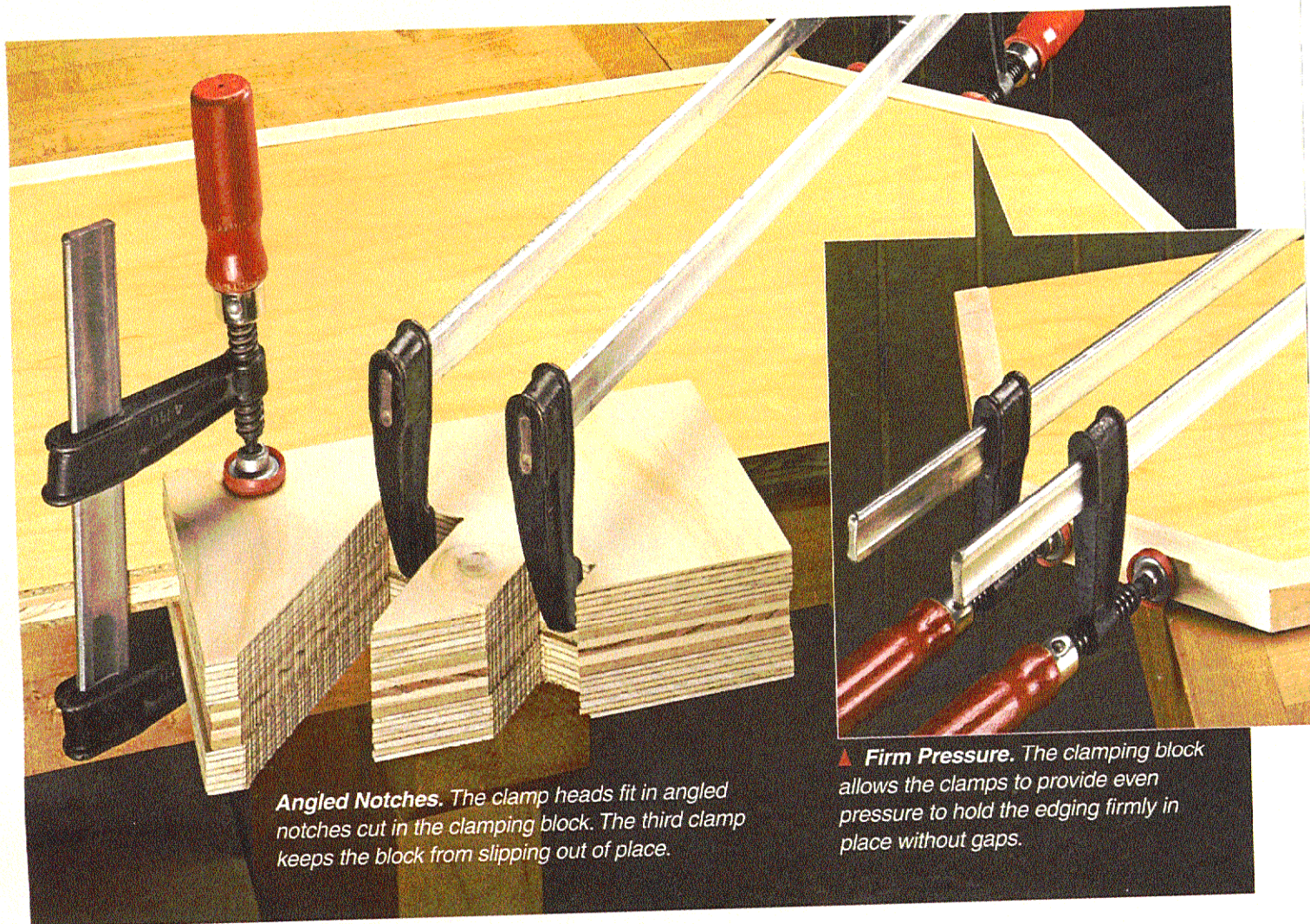

Angled Notches. The clamp heads fit in angled notches cut in the clamping block. The third clamp keeps the block from slipping out of place.

▲ Firm Pressure. The clamping block allows the clamps to provide even pressure to hold the edging firmly in place without gaps.

storage solution

slant-
front
**Tool
Cart**

Store a shopful
of tools and keep them right
where you need them with this
roll-around tool cart.

Expanded View Details

OVERALL DIMENSIONS
19 1/4"D x 27 1/2"W x 47 7/8"H

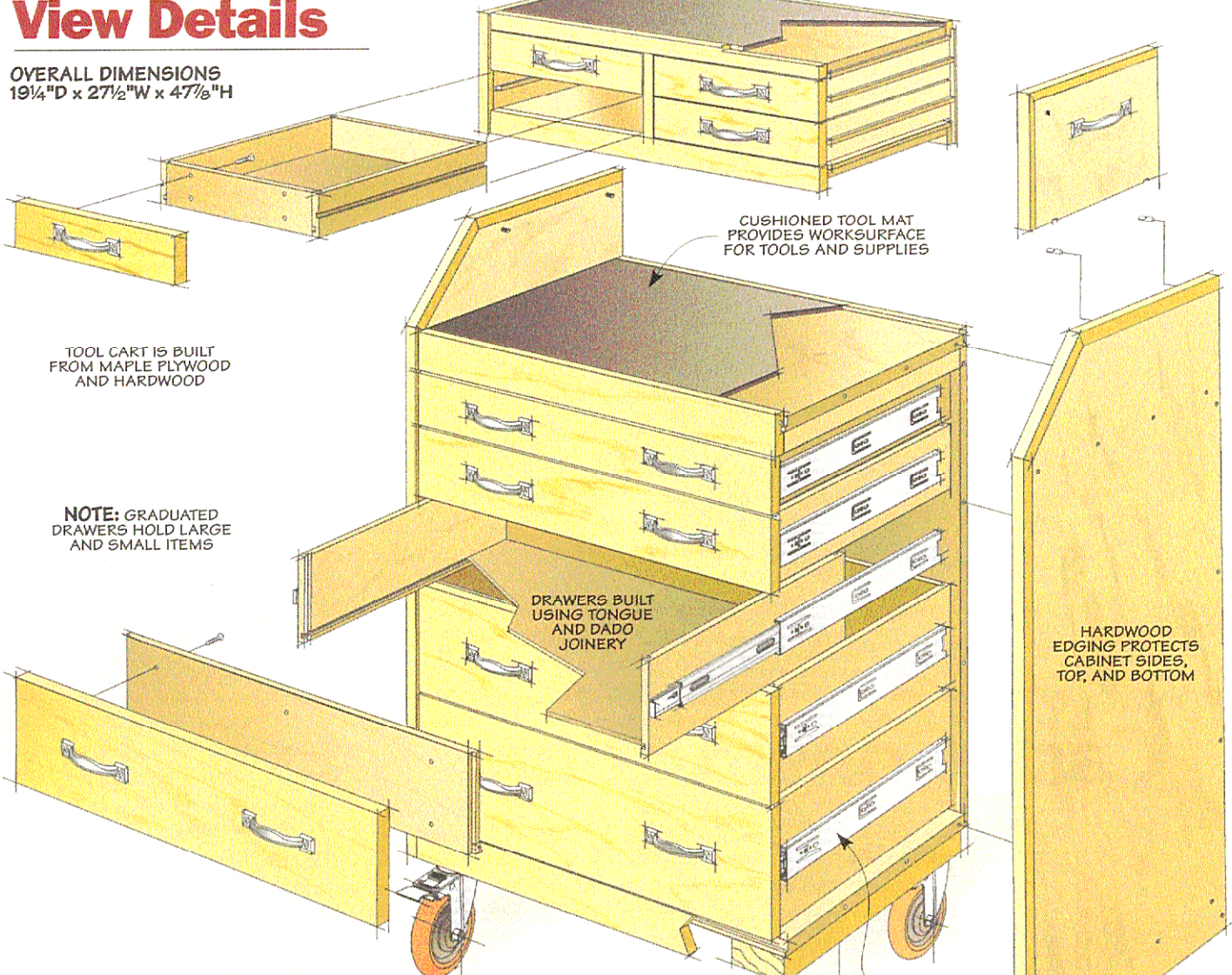

ShopNotes

GO ONLINE EXTRAS

To download a free cutting diagram for the Tool Cart, go to: www.ShopNotes.com

HEAVY-DUTY LOCKING SWIVEL CASTERS ALLOW MOBILITY AROUND THE SHOP

DRAWERS RIDE ON FULL-EXTENSION SLIDES

CASE ASSEMBLY REINFORCED WITH SCREWS AND FINISH WASHERS

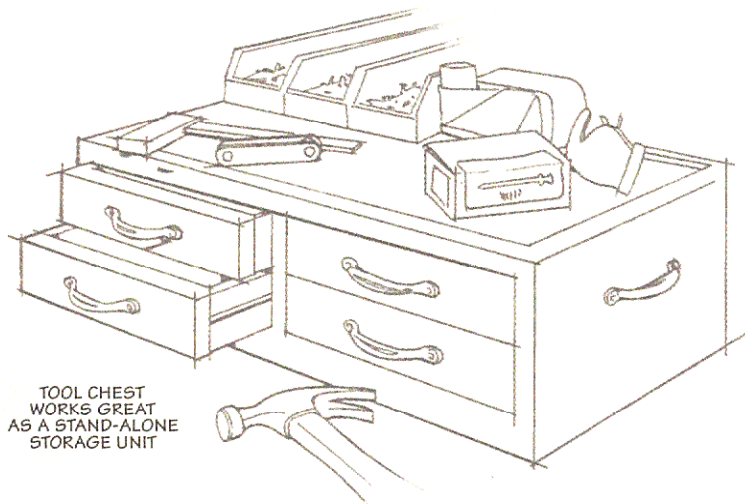

EASY-TO-ADD SHELF PROVIDES ADDITIONAL STORAGE AND WORKSURFACE

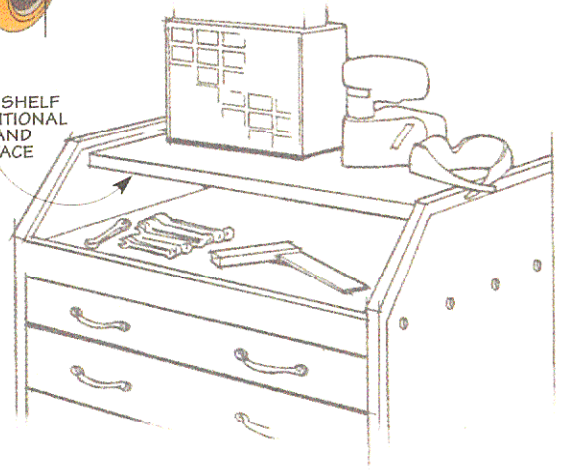

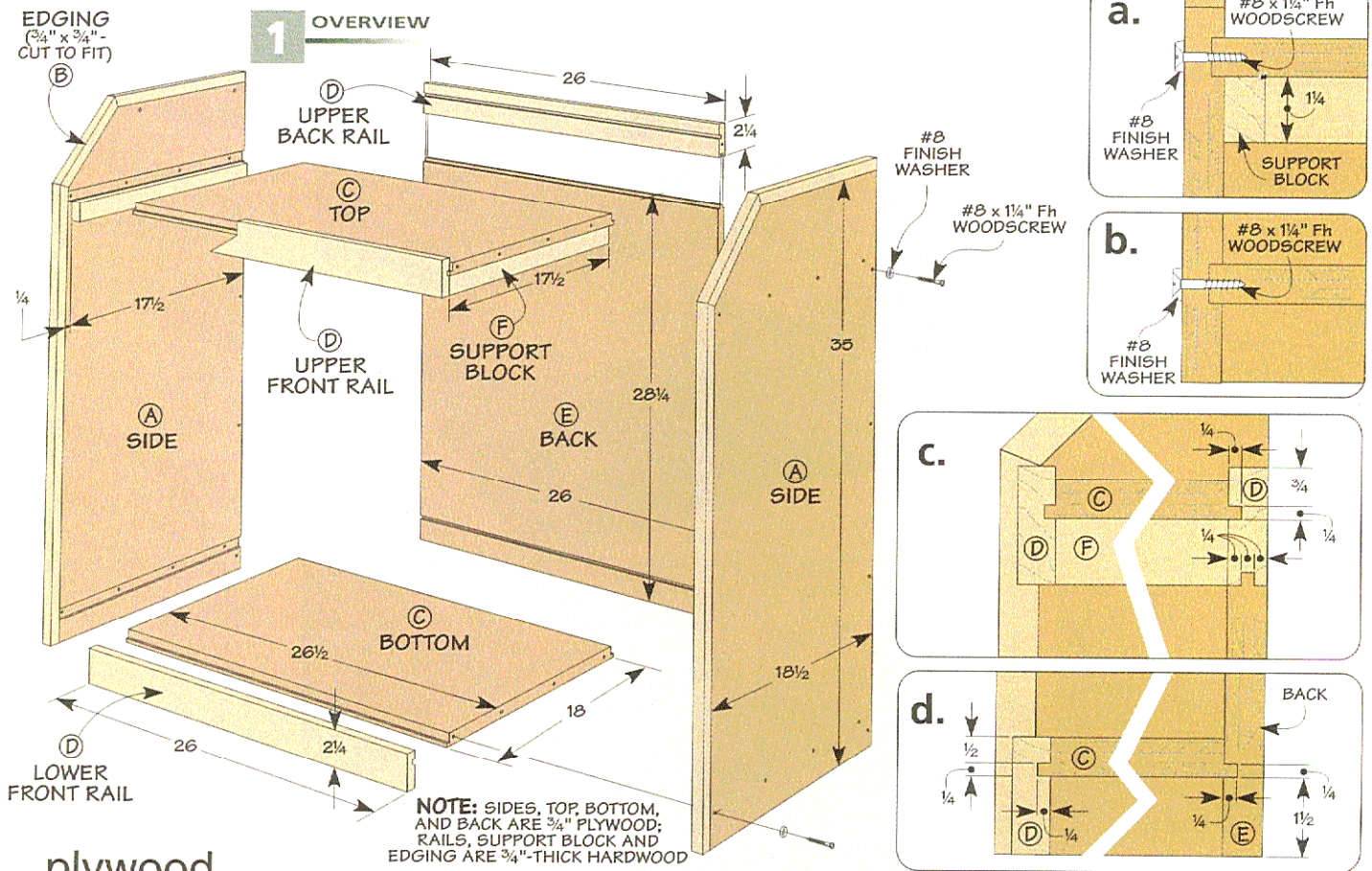

plywood Case Construction

I started building the tool cart by working on the main case. As you can see in the drawing above, it's nothing more than a large plywood box that consists of a top and bottom, a pair of sides, and a back. A set of hardwood rails added to the top and bottom of the cart hides the plywood edges and helps prevent the cart from racking.

START WITH THE SIDES

To help keep everything aligned, the top and bottom fit into dados cut into the sides of the case, as illustrated in Figure 2. Take some time here to ensure the good face of each plywood side faces out before cutting the dados.

Once the dados are cut, you can trim the front corner of each side to create the slant front. I did this by making a rough cut with my jig saw to remove most of the waste. Then to clean up the edge, I clamped

a straightedge in place and then used a hand-held router and straight bit to trim the edges perfectly straight and square. If you plan on building the upper tool chest or shelf, now's a good time to drill a pair of shelf pin holes near the top of each side, as in Figure 2.

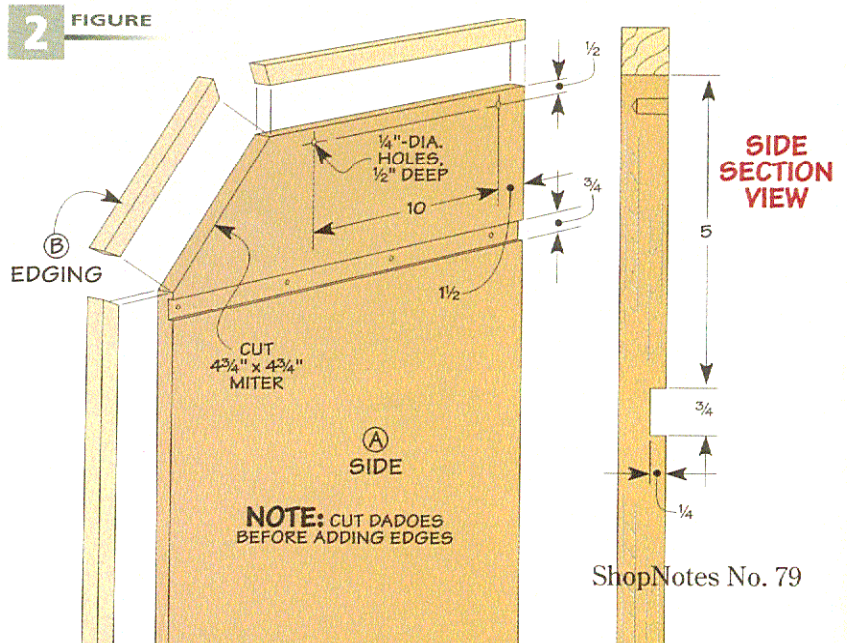

Add Some Edging. To protect the plywood, I added some thick, hardwood edging. Since a couple of the edges won't be seen, you only need to add edging to the front and top of each side (Figure 2).

It can be tricky to securely clamp the edging along the slant. For an easy way to do this, check out the clamping block on page 17. Then to trim the edging flush, check out the box on the opposite page.

ADD THE TOP & BOTTOM

Next, you can turn your attention to the top and bottom of the cart. They're cut to length to fit between the sides of the cart. But before cutting them to width, you'll need to account for a couple things.

Tongue & Groove Joinery. First, the top and bottom have a tongue cut along the front and back edges. These tongues fit into grooves cut into rails at the top and bottom of the cart. You can see how all this works in Figures 1c and 1d.

The rails serve two purposes. For starters, they cover up the plywood edges. But more importantly, they help prevent the cart from racking as it's rolled around the shop.

At the back of the cart, the rail is flush with the sides, but the rail at the front is recessed $\frac{1}{4}$ ". Be sure to account for this when you cut the top and bottom to width. Then you can cut the tongues along each edge.

At this point, I dry assembled the cart using screws and finish washers (Figures 1a and 1b). This makes it easier to accurately cut the front and back rails to final length.

The next step is to cut a narrow groove in each rail. The only thing to keep in mind here is that the groove is located a bit lower in the

3 FIGURE

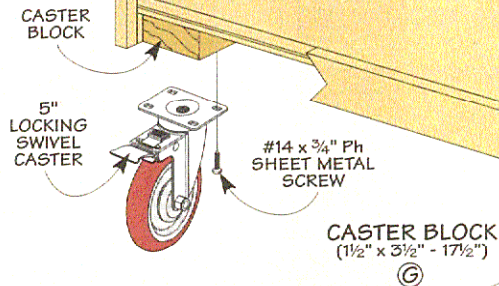

two top rails, like you see in Figure 1c. This forms a lip to prevent any tools resting on top from rolling off during use. The groove in the bottom rail is located so the top of the rail is flush with the upper face of the cart bottom.

Sizing the Back. Before you can assemble the cart, you'll need to cut the back to size. To do this, I cut the back to width so it fit between the sides of the case.

Before cutting the back to length, I cut a groove along the bottom edge of the back rail and then cut a tongue on the top edge of the back to fit. To complete the back, I cut a narrow dado near the bottom edge, like you see in Figure 1d. This dado is sized to fit the tongue cut earlier along the back edge of the bottom

At this point, you can assemble the cart with glue, screws, and

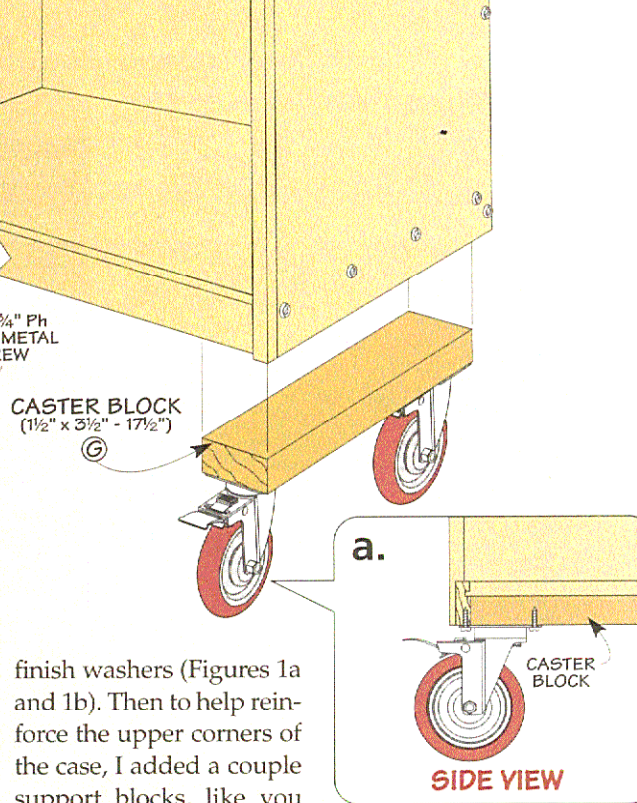

finish washers (Figures 1a and 1b). Then to help reinforce the upper corners of the case, I added a couple support blocks, like you see in Figures 1 and 1a. They're simply glued in place.

MAKING IT MOBILE

To make the cart mobile, I added some heavy-duty casters. To provide a solid mounting point, I added a pair of hardwood support blocks under the bottom of the cart (Figures 3 and 3a). After gluing the blocks in place, you can screw the casters in place.

Trimming Edging Flush

Plywood is a great material to use any time you build a large project for the shop. But to make it look its best, I like to add hardwood strips to cover up the plywood edges.

Gluing on a strip of edging isn't all that difficult. But making sure it's perfectly flush with both sides can be a challenge. So instead, I like to glue extra-wide edging in place and then trim it flush with each face of the plywood. A hand-held router and flush trim bit make quick work of the task (see photo).

The problem is keeping the router steady as you work. A handy way to form a solid support surface for the router is to clamp the two sides together with a

spacer in between. You can see how this works in the drawing below.

After routing down one side and back up the other, just repeat the process for the other edges. You'll need to flip the sides and clamp them back together to trim the edging flush on the other two faces.

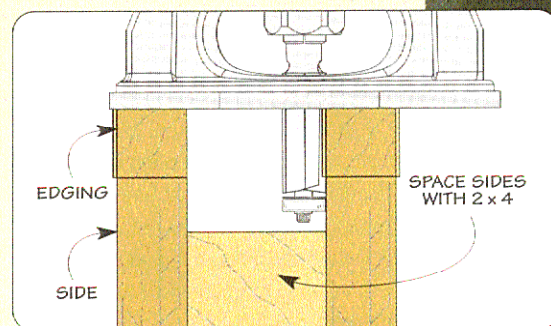

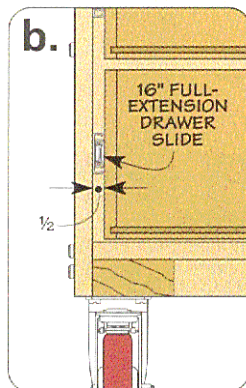
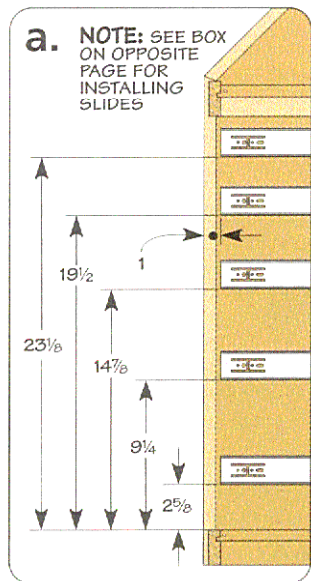

4 FIGURE

16" FULL-EXTENSION DRAWER SLIDE

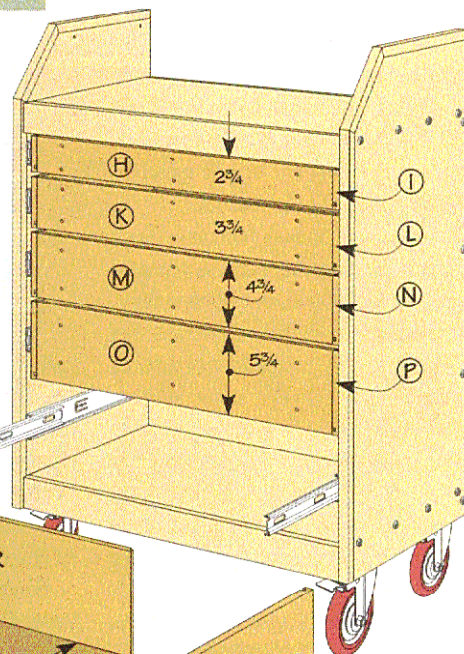

PILOT HOLES TO ATTACH FALSE FRONT TO DRAWER

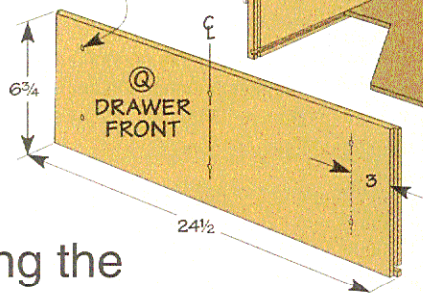

NOTE: ALL DRAWER PARTS ARE 1/2"-THICK HARDWOOD EXCEPT DRAWER BOTTOMS ARE 1/4" HARDBOARD

making the Drawers

With the main case complete and resting on the casters, you can roll it up to your workbench and start

working on building and installing the drawers and false fronts.

As you can see in the photo and drawing above, the cart has five drawers. And each one slides on

full-extension metal drawer slides. The type of slide I used comes in two parts. One part is screwed to the side of the cart. And the other is attached to the drawer. But more about that later.

For now, let's concentrate on the drawers. Each drawer is just a shallow box with a false front. The only difference among the drawers is the height. All the information you'll need to complete each drawer is detailed above. Just be sure to account for the thickness of each drawer slide use as you size the parts. (As in Figure 4b, I had to account for a total of 1" — 1/2" for each drawer slide.)

Solid Joinery. The drawers are built with tongue and dado joinery. You can read more about this in the box below. Once you've completed the joinery, you can cut a groove on the inside face of all of the parts to hold a 1/4" hardboard bottom and then assemble the drawers.

Install the Drawers. At this point, you're ready to install the

Making a Tongue & Dado Joint

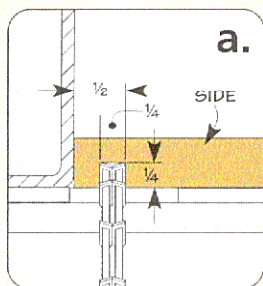

Drawers take a lot of abuse with all the opening and closing that goes on. So you want to be sure the joinery you use for the drawer will stand up.

The drawer joint I like to use is a tongue and dado joint, like you see in the photo at right. The joint is strong, sturdy, and simple to make. The first step is to cut a dado in the drawer sides, as shown in detail 'a' at left. Just be sure the inside edge of the dado matches the thickness of the drawer front and back.

The tongue that makes up the other half of the joint is made by cutting a rabbet at the end of the workpiece, as in detail 'b.' To ensure a good fit, I find it best to sneak up on the cut until the tongue slips snugly into the dado.

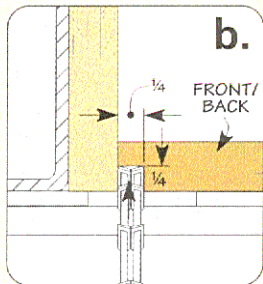
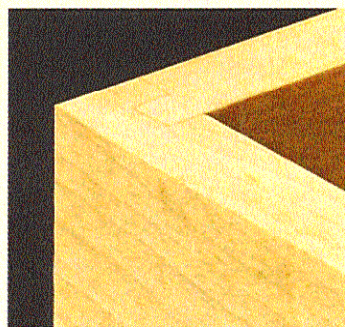

drawers. And that means installing the two-part drawer slides.

For the drawers to slide smoothly, the slides need to be installed perfectly level and each set needs to be installed at the same height. But instead of trying to measure and lay out the location of each slide, I used a simple technique shown in the box below to accurately install each slide with ease.

ADD THE FALSE FRONTS

Once you've installed the drawer slides, you're ready to complete the cart by adding a set of false fronts, like you see in Figure 5.

Sizing the False Fronts. To provide a clean look, you'll want to allow for a consistent gap around each false front. For the size of the drawers in this cart, an $\frac{1}{8}$ " gap provides just the right look (Figure 5a).

The next step is to size each false front. Determining the length is a snap. Just measure the width of your cabinet opening and subtract $\frac{1}{4}$ " to allow for the gaps.

Next, you'll need to determine the height of each false front. To do that, start by measuring the opening between the upper and lower front rails and then subtract $\frac{3}{4}$ " to account for the six "gaps."

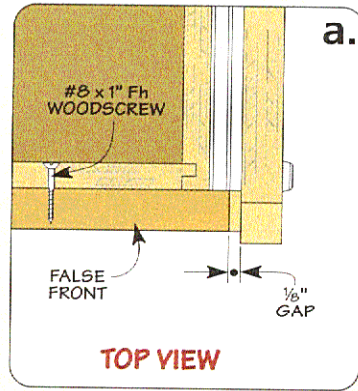

TOP VIEW

The measurement that results is what you have to "divide" up between the false fronts. For my cart, this worked out to false fronts that varied in increments of 1", starting with 3" at the top and ending with 7".

To make it easy to install the false fronts, I started at the bottom of the cart. First, slide the bottom drawer in place. Then to account for the $\frac{1}{8}$ " gap, stack a pair of pennies under each end of the bottom false front. After clamping the false front to the drawer, you can screw it in place.

Installing the other drawers is just a matter of repeating the

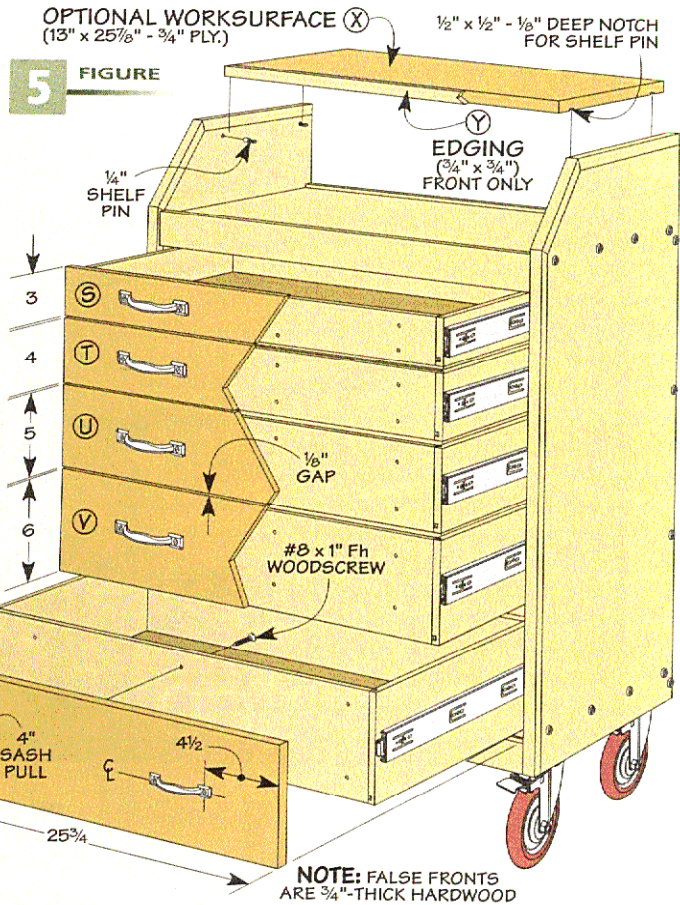

process as you work your way up. Note: For the last false front, I had to slide the top two drawers out a bit so I could get the clamps in place. Once that was complete, I screwed a pair of pulls to each drawer.

Installing Drawer Slides

When it came time to install the drawers in the tool cart, I turned to a handy little technique to ensure that each slide was perfectly level and at the right height — and all it takes is a scrap piece of plywood (photo at right).

Top Down. Working from the top of the cart, cut a piece of plywood so it matches the height you need to install the first drawer slide (Figure 4a). With the scrap against the side of the cart, set the drawer slide on top. After positioning the slide 1" back from the front edge, screw the slide in place. To install the slide on the opposite side, move the scrap over and repeat the process.

To complete the installation of the other slides, just trim the height (width) of the plywood to match the position for the next set. Then simply repeat this process.

Once the slides in the case are in place, you can install the other half of each set on the drawers. This is just a matter of centering each slide on the drawer side and screwing it in place, as in the drawing at right.

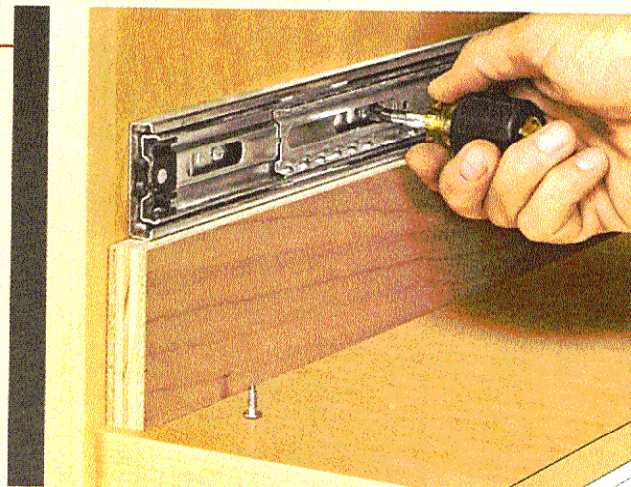

▲ **Installing Slides.** A scrap of plywood makes it easy to level a drawer slide. The other half of the slide is centered on the drawer side and screwed in place (right).

SHOP TIP

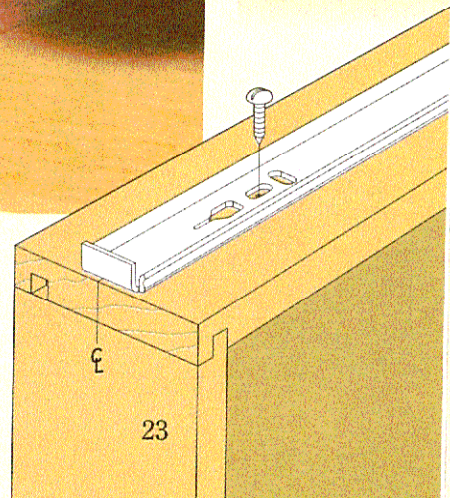



benchtop

Tool Chest

To complement the tool cart, I built the tool chest shown above. You can even use it as a stand-alone tool chest right at your workbench to keep all your smaller hand tools close by. Or you can install it on the top of the tool cart by resting it on the shelf pins installed in the sides.

The design of the upper tool chest is similar to the cart — it's basically a plywood box with strips of hardwood edging. The four drawers provide handy storage for

tools and supplies. You can get an idea of how the tool chest goes together by checking out Figure 1.

Make the Sides. The first step is to cut the sides of the case to size. While you're at it, it's a good idea to cut a matching center divider. Why? When you're ready to cut the dadoes for the hardwood guides that support the drawers, it ensures they're all aligned identically.

Once you have the sides and divider cut to size, you're ready to

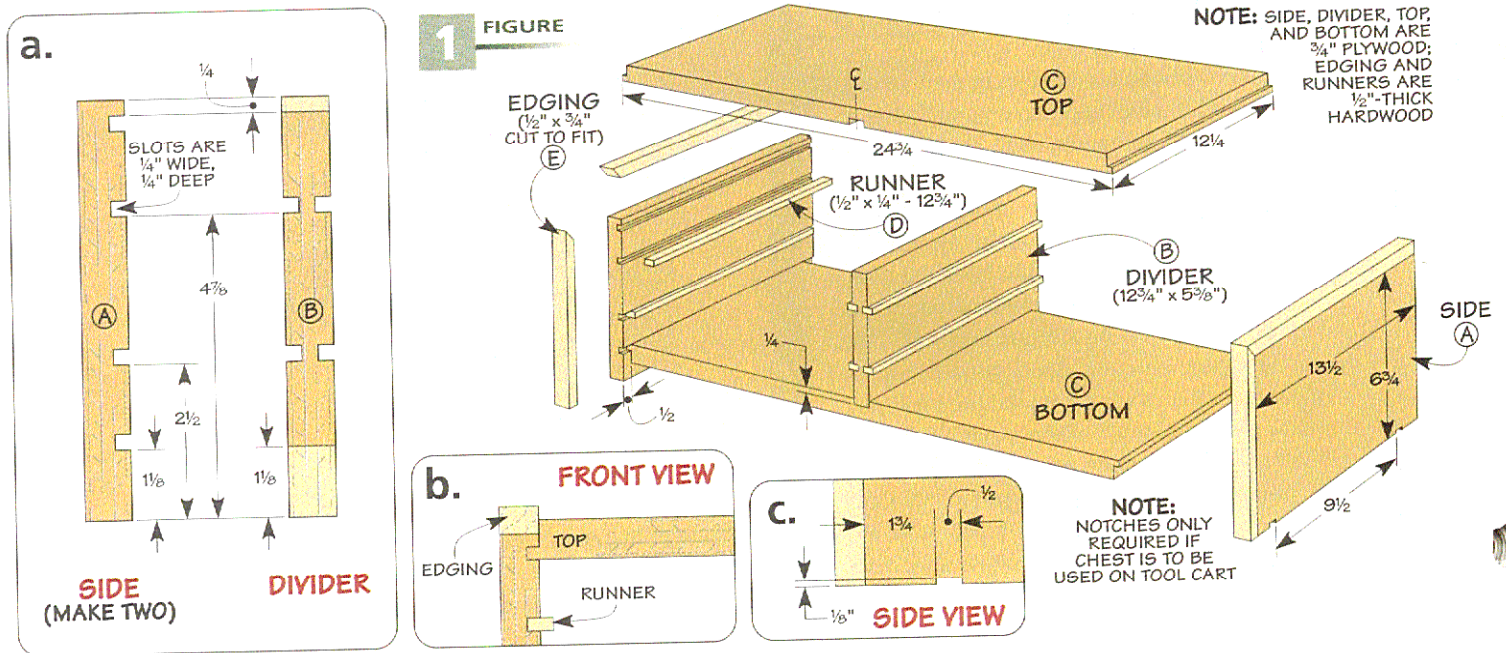

cut a few dados. As you can see in Figure 1, all the dados are the same size ($\frac{1}{4}'' \times \frac{1}{4}''$), so once you have your dado blade set up in your table saw, this work goes quick. While you're at it, cut a rabbet along the back edge of each side and a couple notches in the bottom of each side. The rabbet will accept the back of the chest and the notches "lock" the chest in place when you set it on the shelf pins.

The Top & Bottom. At this point, you can turn your attention to the top and bottom of the chest. As Figure 1 shows, the top and bottom are identical. Simply cut them to size (they are narrower than the sides of the case) and then cut tongues on each end to fit the dados in the case sides.

To complete the top and bottom, cut a centered dado in each part to match the thickness of the divider. After dry assembling the top, bottom, and sides, you can do the final sizing of the center divider.

Trim the Divider. The key is to trim just enough off the divider so that it fits between the top and bottom, while keeping the dados for the shelf guides aligned with each other. For the final length, cut the divider so it's flush at the front and sticks out a $\frac{1}{2}''$ at the back end.

Add the Runners. Once you have the divider complete, you can cut the drawer runners to size

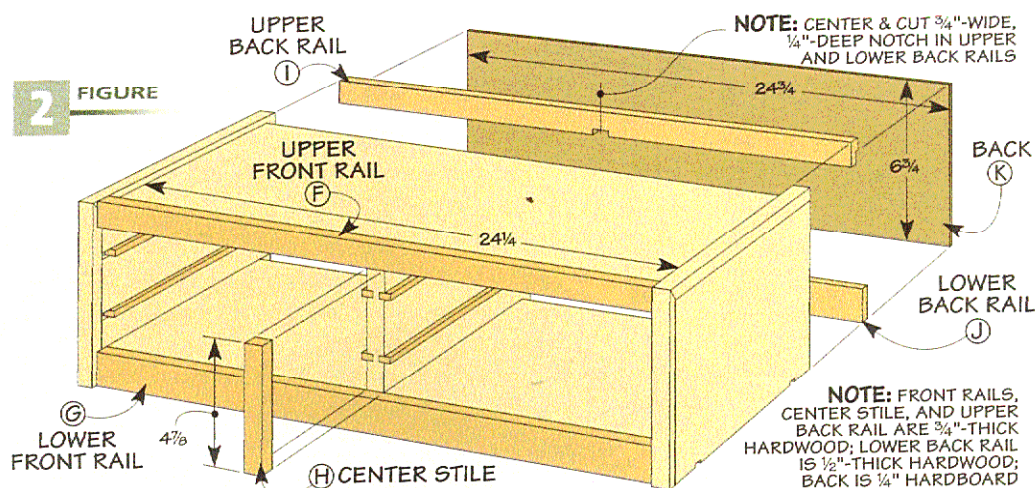

(they're the same length as the divider). To do this safely, check out the box below. Finally, glue the runners in place flush with the back edge of the sides and divider.

Assemble the Chest. At this point, you're ready to assemble the chest. Be sure the top and bottom are $\frac{1}{2}''$ back from the front edge of the sides and that the divider is flush with the top and bottom at the front of the case.

Add the Hardwood Edging. You're on the home stretch at this point. The next thing to do is add some hardwood edging to the front and top edges of the sides. You can see this in Figure 1.

With that complete, you can attach the hardwood rails and stile that cover the plywood edges of the top, bottom, and divider, fitting them as shown in Figure 2.

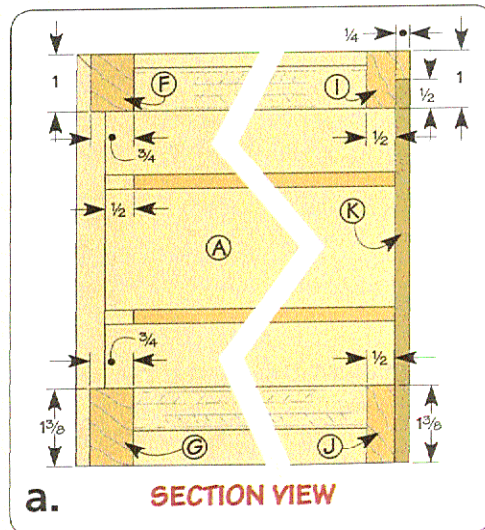

The upper back rail has a notch cut in it to fit around the divider, and it's rabbeted to accept the back of the chest. The lower back rail is thinner, so you only need to cut a center notch. Once all the rails are glued in place, you can attach the back.

Ripping Narrow Strips

When ripping the narrow strips for the drawer runners on the tool chest, I used a simple jig that slid against the rip fence on the table saw, as in the drawing at right.

The jig consists of a single part — a plywood base with a notch in it that matches the desired width of the strip. Since the strips are narrow, it's best to replace the standard insert plate with a zero clearance version. This prevents any strips from jamming in the

opening. And a hardboard splitter glued into place just behind the blade helps prevent kickback.

Using the Jig. To set up the jig, start by positioning the rip fence so the outside edge of the notch aligns with the inside of the saw blade, as in the detail. After fitting the workpiece in the notch, push the jig past the saw blade to rip the first runner. Simply repeat the process until you have all the runners you need.

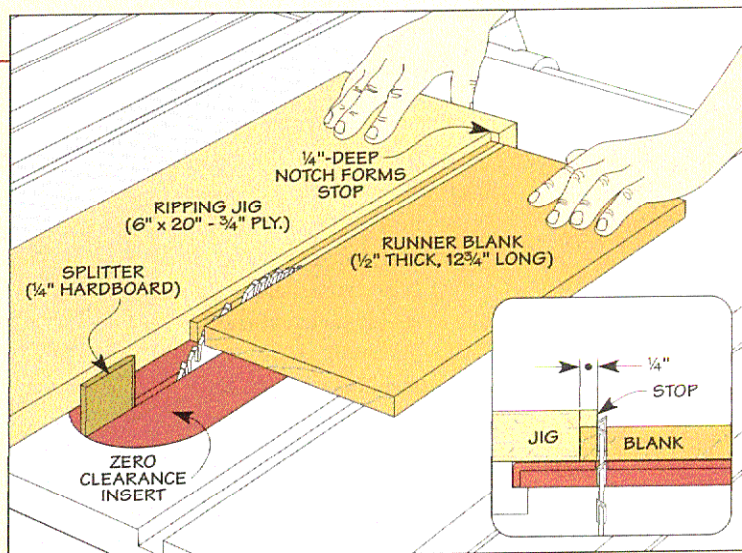

3 FIGURE

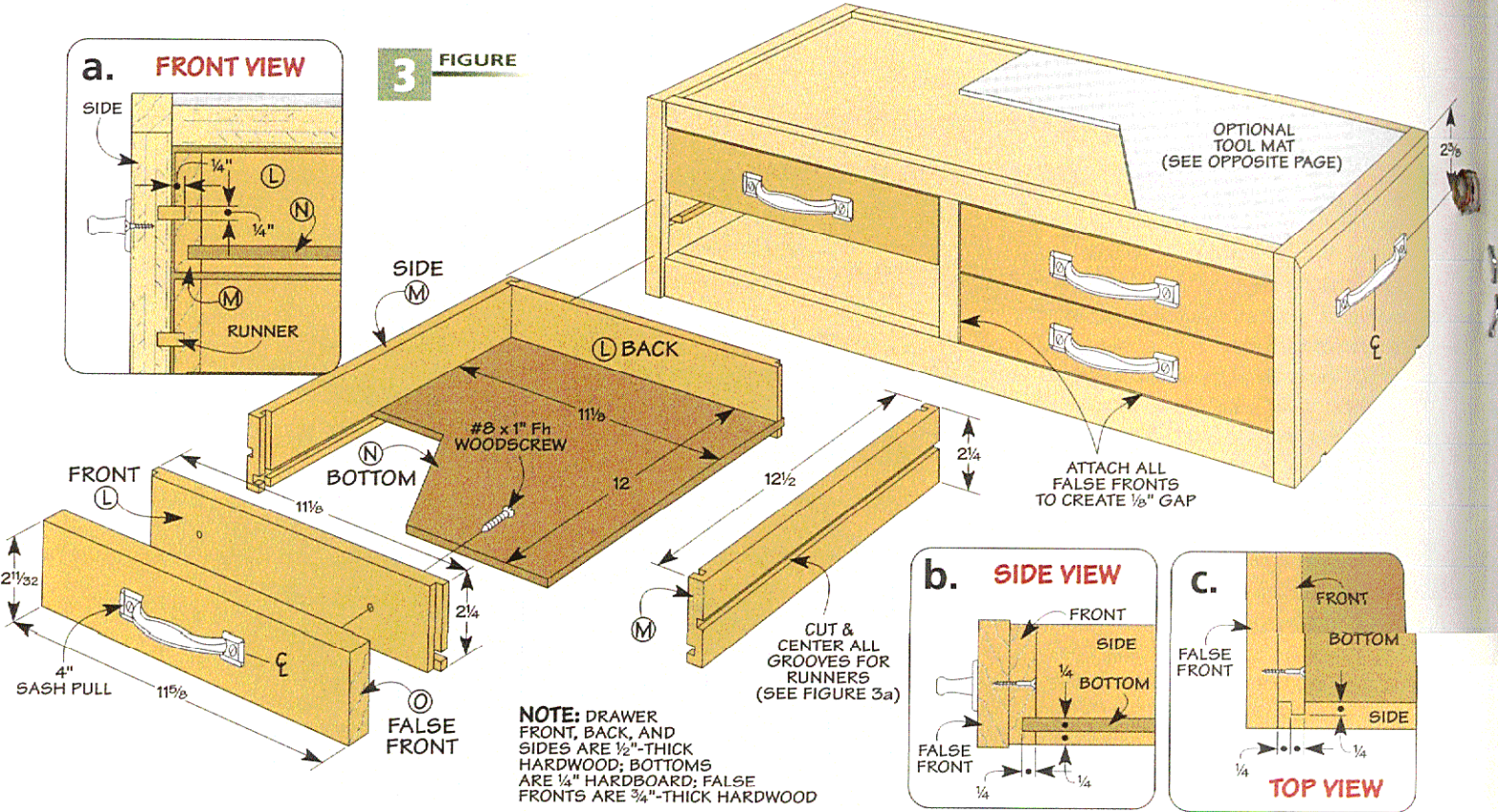

NOTE: DRAWER FRONT, BACK, AND SIDES ARE 1/2"-THICK HARDWOOD; BOTTOMS ARE 1/4" HARDBOARD; FALSE FRONTS ARE 3/4"-THICK HARDWOOD

a matched set of Drawers

After completing the tool chest case, all that's left to do is add a set of four drawers and hardware, like you see in the drawing above.

Sizing the Drawers. There are a couple things to keep in mind as you size the drawers. First, since the drawers don't ride on full-extension slides, you don't have to account for any slide thickness

when sizing the drawer fronts and backs. But you do need to allow a little clearance so the drawers won't bind as you slide them in and out. A total of 1/8" clearance side to side, as well as above, below, and between each drawer should keep the drawers sliding smoothly in the tool chest. And to ensure the drawers stop against the false fronts that are added later, the drawer sides are 1/2" shorter (12 1/4") than the length of the runners.

After cutting all the parts to size, the next step is to cut the joinery for

the drawers. Here again, I used a tongue and dado to join the front and back to the sides. And a groove in the bottom of all the parts accepts the hardboard drawer bottom (Figures 3, 3a, and 3b). There's one more thing you'll need to do to complete the drawer sides. And that's to cut a groove on the *outside* face of each drawer side to support the drawer on the runners inside the tool chest.

These grooves are centered on the side of each drawer. And they're cut just a hair wider than

SHOP TIP

Grain-Matching Drawer Fronts

Making the drawers for the tool chest is the perfect opportunity to try your hand at grain-matching a set of false fronts, like you see in the drawing at right.

It's a small detail that sets apart any project. And all it takes is a workpiece wide and long enough to cut all the false fronts from while allowing for a bit of waste and final trimming.

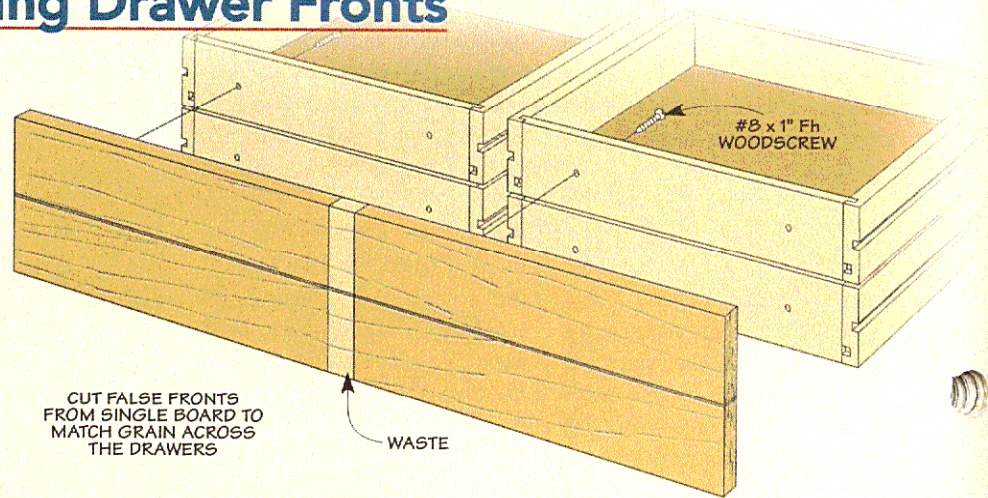

the thickness of the drawer runners. This way, with a little coating of wax, you can be sure the drawers will slide in and out smoothly.

With all the joinery complete, you can cut the 1/4" hardboard drawer bottoms to size and assemble each drawer.

Make the False Fronts. Like the drawers in the lower tool cart, the drawers in the tool chest have false fronts to hide the exposed runners. Plus, the false fronts act as a stop for the drawer as they contact each runner.

Although you can make the false fronts individually, I took some time to match the grain on all the drawer fronts by cutting them from a single board. You can read more about this in the Shop Tip box on the opposite page.

No matter how you make the false fronts, you'll need to allow for consistent gaps around the tool chest. Instead of the 1/8" gap on the drawers in the tool cart, I tightened it up to 1/16".

Just like the cart, the false fronts are screwed in place from the inside of the drawer and then the pulls are screwed in place from the front. To make it easy to lift the tool chest off the cart and carry it around, I added a matching pull to each side of the tool chest to act as a handle, as illustrated in Figures 3 and 3a.

Protecting Your Stuff. Finally, to provide a finishing touch to both the tool cart and chest, I added a little "protection" to the inside and outside — tool mats. You can read more about the tool mats in the box at right.

After applying a finish and letting it dry, you can roll your tool cart around the shop, collect all your hand tools and supplies, and then get them organized — once and for all. 

Finishing Touch — Tool Mats

Like most flat surfaces in my shop, the top of the tool cart and tool chest are sure to become resting spots for all kinds of things. To protect the top of the tool cart (and tool chest), I added some protective tool mats, like you see in the margin and photo below.

The mats are available at most home centers and hardware stores — in a number of different types and styles. Besides different textures, some of the tool mats are designed to be non-slip, which keeps tools and other items stored in the drawers from sliding around. I used non-slip mats in the drawers and the "beefier" diamond pattern for the tops of both the tool cart and tool chest.

The mats come rolled up or in a flat package like a set of placemats. With either type, you'll probably have to use a utility knife to cut them to size to suit your needs.

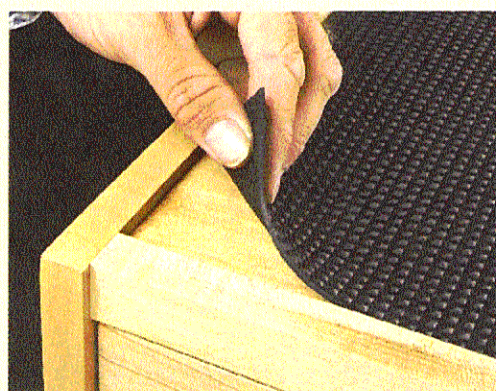

Extra-thick mats made from recycled tires protects tools and cart from bumps and dings

Thin, non-slip, cushioned mats are cut to size and protect tools and keep them from moving around

Non-slip, pre-sized mats come as a set to fit metal tool cart drawers, but can be sized as required for other uses

Materials & Hardware

Tool Cart Case

A	Sides (2)	18 1/2 x 35 - 3/4 Ply.
B	Edging	3/4 x 3/4 - 10 Lnr. Ft.
C	Top/Bottom (2)	18 x 26 1/2 - 3/4 Ply.
D	Rails (3)	3/4 x 2 1/4 - 26
E	Back (1)	26 x 28 1/4 - 3/4 Ply.
F	Support Blocks (2)	3/4 x 1 1/4 - 17 1/2
G	Caster Blocks (2)	1 1/2 x 3 1/2 - 17 1/2

Tool Cart Drawers & Shelf

H	Drawer Front/Back (2)	1/2 x 2 3/4 - 24 1/2
I	Drawer Sides (2)	1/2 x 2 3/4 - 17
J	Drawer Btms. (5)	16 1/2 x 24 1/2 - 1/4 Hdbd.
K	Drawer Front/Back (2)	1/2 x 3 3/4 - 24 1/2
L	Drawer Sides (2)	1/2 x 3 3/4 - 17
M	Drawer Front/Back (2)	1/2 x 4 3/4 - 24 1/2
N	Drawer Sides (2)	1/2 x 4 3/4 - 17
O	Drawer Front/Back (2)	1/2 x 5 3/4 - 24 1/2
P	Drawer Sides (2)	1/2 x 5 3/4 - 17
Q	Drawer Front/Back (2)	1/2 x 6 3/4 - 24 1/2

R	Drawer Sides (2)	1/2 x 6 3/4 - 17
S	False Front (1)	3/4 x 3 - 25 3/4
T	False Front (1)	3/4 x 4 - 25 3/4
U	False Front (1)	3/4 x 5 - 25 3/4
V	False Front (1)	3/4 x 6 - 25 3/4
W	False Front (1)	3/4 x 7 - 25 3/4
X	Optional Shelf (1)	13 x 25 7/8 - 3/4 Ply.
Y	Optional Shelf Edging	3/4 x 3/4 - 25 7/8

Tool Chest Case

A	Sides (2)	13 1/2 x 6 3/4 - 3/4 Ply.
B	Divider (1)	12 3/4 x 5 3/8 - 3/4 Ply.
C	Top/Bottom (2)	12 1/4 x 24 3/4 - 3/4 Ply.
D	Drawer Runners (8)	1/2 x 1/4 - 12 3/4
E	Edging	1/2 x 3/4 - 4 Lnr. Ft.
F	Upper Front Rail (1)	3/4 x 1 - 24 1/4
G	Lower Front Rail (1)	3/4 x 1 3/8 - 24 1/4
H	Center Stile (1)	3/4 x 3/4 - 4 7/8
I	Upper Back Rail (1)	3/4 x 1 - 24 1/4
J	Lower Back Rail (1)	1/2 x 1 3/8 - 24 1/4

K	Back (1)	6 3/4 x 24 3/4 - 1/4 Hdbd.
---	----------	----------------------------

Tool Chest Drawers

L	Drawer Fronts/Backs (8)	1/2 x 2 1/4 - 11 1/2
M	Drawer Sides (8)	1/2 x 2 1/4 - 12 1/2
N	Drawer Bottoms (4)	11 1/8 x 12 - 1/4 Hdbd.
O	False Fronts (4)	3/4 x 2 11/32 - 11 5/8

- (24) #8 x 1 1/4" Fh Woodscrews
- (24) #8 Finish Washers
- (4) 5" Locking Swivel Casters
- (16) #14 x 3/4" Ph Sheet Metal Screws
- (5 Pr.) 16" Full-Extension Metal Drawer Slides w/screws
- (38) #8 x 1" Fh Woodscrews
- (16) 4" Sash Pulls w/screws
- (4) 1/4" Shelf Pins
- Tool Mats (Optional)



edging with **T-Molding**

Inexpensive and easy to install, T-molding is a durable, good-looking alternative to hardwood edging.

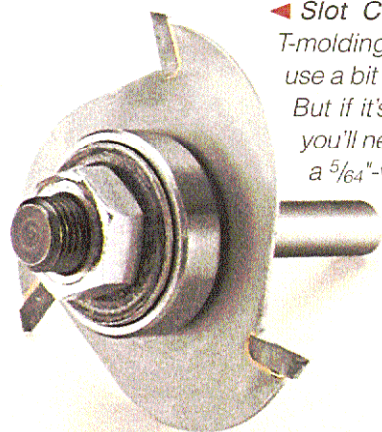

◀ **Slot Cutter Bit** . For T-molding up to $\frac{3}{4}$ " wide, use a bit with a $\frac{1}{16}$ " cutter. But if it's wider than $\frac{3}{4}$ ", you'll need one that cuts a $\frac{5}{64}$ "-wide slot.

■ Covering the exposed edges of plywood with hardwood strips can be a time-consuming process. Veneer is an option, but the thin strips don't stand up to much abuse. An option I like to use sometimes is edgbanding with T-molding.

Made of a durable plastic, T-molding has a smooth, rounded top edge with a barbed tongue in the shape of a "T." It's held in place by inserting the tongue inside a slot that's routed in the edges of a workpiece.

Choosing T-molding. Plastic T-molding is available in a wide variety of colors, styles, and widths, as you can see in the photos on the next page. And best

of all, T-molding is easy to install.

The first thing to consider when choosing T-molding is the width of your workpiece. I found sources for T-molding as narrow as $\frac{1}{2}$ ", all the way up to $1\frac{1}{2}$ ". This makes it easy to match the width to the thickness of the stock you're using. (See page 51 for sources.)

But what I like best about T-molding is how easy it is to work with. All you need are a slot-cutter bit for your router and a few hand tools to trim and install it.

Slot-Cutter Bit. Cutting the slot is pretty simple as well. Start by using a scrap piece of plywood to make a test cut. Then simply eyeball the depth, using the plywood

as a gauge. Rout a test slot, then flip the workpiece over and rout it again, so the slot ends up centered on the thickness of the workpiece.

Test Fit. Now tap in a small scrap section of molding. If the edges of the molding line up flush with the edges of the stock and it fits snugly, you're set. If not, raise (or lower) the slot cutter a fraction and try again. The goal is to center the slot exactly.

Installing T-molding. Once the slots are routed in a workpiece, I use a dead blow mallet to tap the T-molding in place. And to avoid marring the molding with the mallet, I like to use a short U-shaped piece of scrap (photo above right). A groove cut down the center with a dado set keeps the scrap centered over the workpiece.

Note: I cut a 45° bevel on one end of the scrap piece. Later on when you join the ends of the molding, you'll see why this comes in handy

Dealing with Corners. The T-molding easily fits around gradual bends and curves. But for tight corners, you'll have to notch the barbed section to get it to bend. I use flush-cutting pliers to do this (top photo below). The notch doesn't need to be too big. A couple of cuts will usually do the job.

Overlap Ends. The U-shaped scrap piece can also be used to guide a utility knife when you "splice" the two ends together. Just overlap the ends slightly and slice through *both* pieces at once, as you can see in the bottom photo below. Note: Be sure to trim back a little of the barb so the top piece lays flat.



Tap it in Place.
Gently tap the T-molding in the slot with a mallet and a piece of scrap.

Fast and Easy. T-molding looks great and it lasts. But the thing I like best is that I can complete an entire project with T-molding in the time it normally takes to edgeband just one piece with hardwood. 🛠️

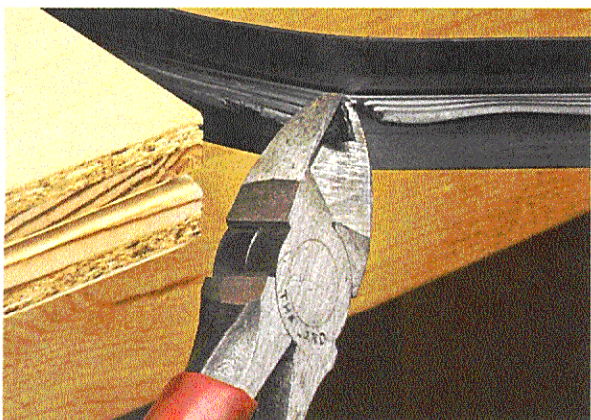

▲ **Notch It.** Fitting the molding around a 90° corner requires a notch. I used flush-cutting pliers to cut a small V-shaped piece from the barbed section.

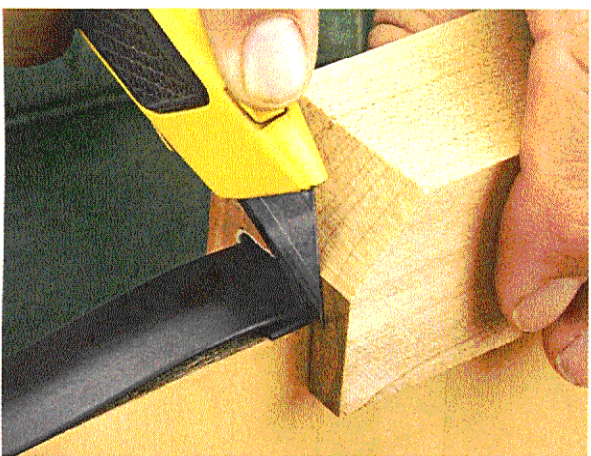

▲ **Splicing the Ends.** Where the T-molding butts together, you'll need to overlap it slightly and splice the ends to form a seamless fit.

NARROW: To edgeband small, light-weight projects, 1/2"-wide T-molding is available for thin sheet goods

WHITE: This version is slightly wider than standard plywood (13/16") for projects made of laminated sheet goods

PROTECTION: This T-molding has two outside lips that fit down tightly over the edge of a project to offer even more protection

WIDE: Some projects require molding wide enough (1 1/2") to cover two sheets of plywood laminated together

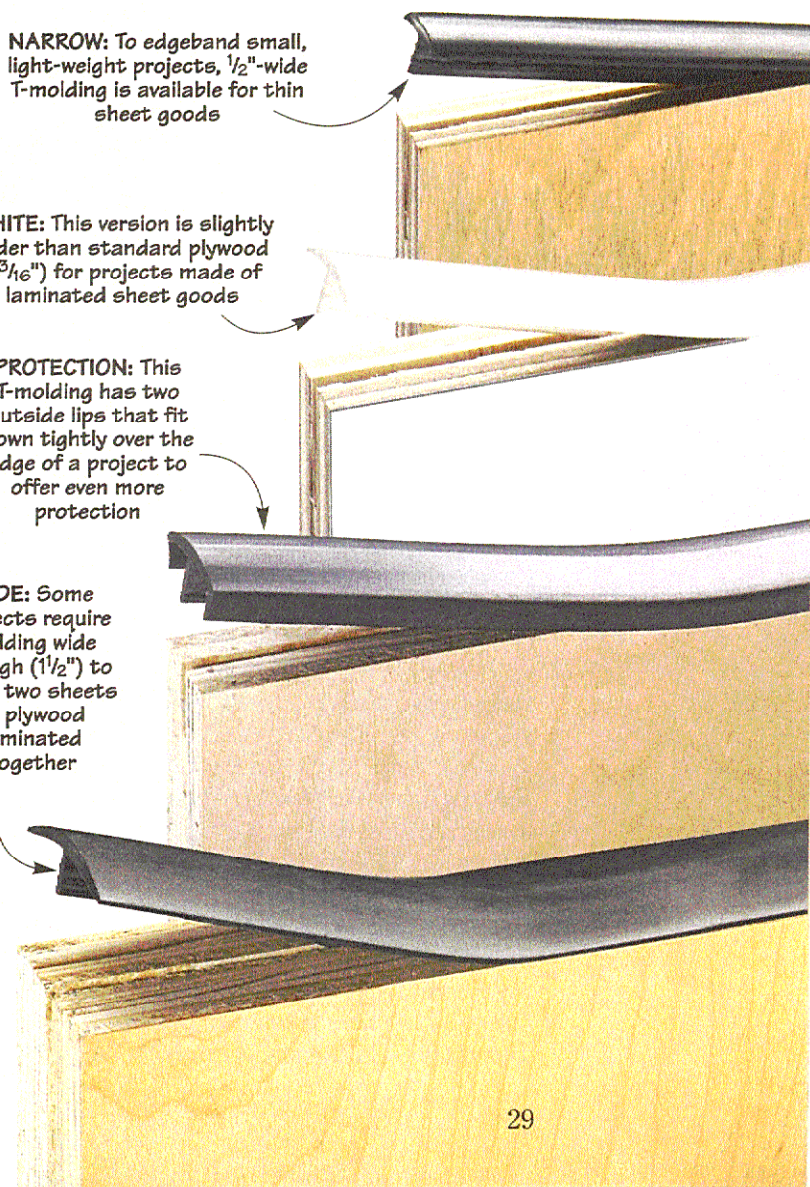

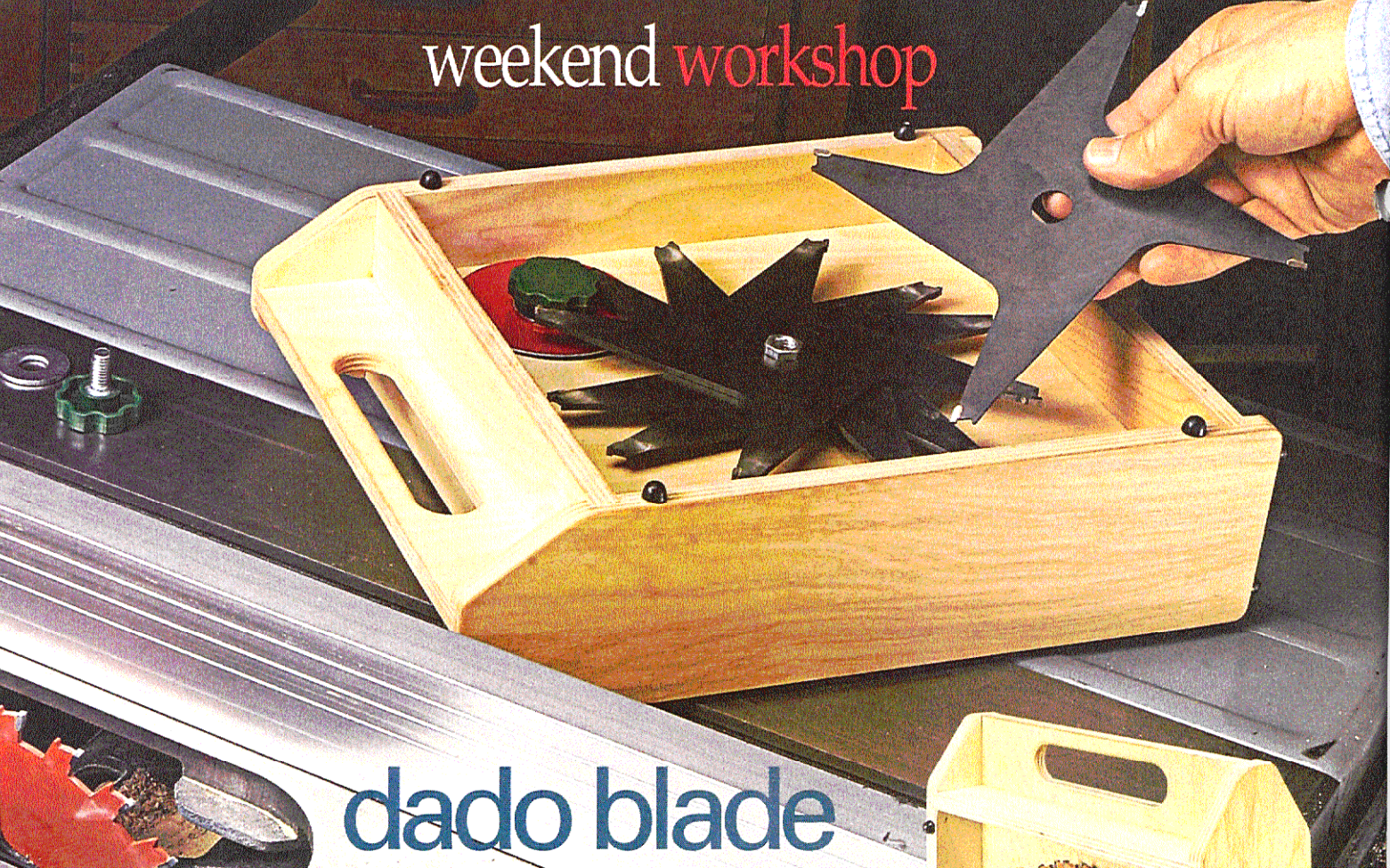

dado blade

Storage Case

Use your dado blade to build its own storage case and keep everything organized and protected.

■ It seems like I use the dado blade in my shop almost every day. So it didn't take long for the bulky cardboard box the blade came in to fall apart.

To solve this problem, I made this easy-to-build storage case to keep all the parts together and within easy reach. All you have here is a two-sided open case. One side holds the scoring blades, and the opposite side holds the chippers and shims, as in the photo on the left. To keep the case lightweight yet sturdy, I built it from 1/2" Baltic birch plywood and used basic dado joinery to put it together.

Getting Started. If you take a look at the drawing on page 31, you'll see how the case goes together.

Since the sides (A) and bottom (B) are the same width and will have the same center groove, I found it easier to make them all at the same time.

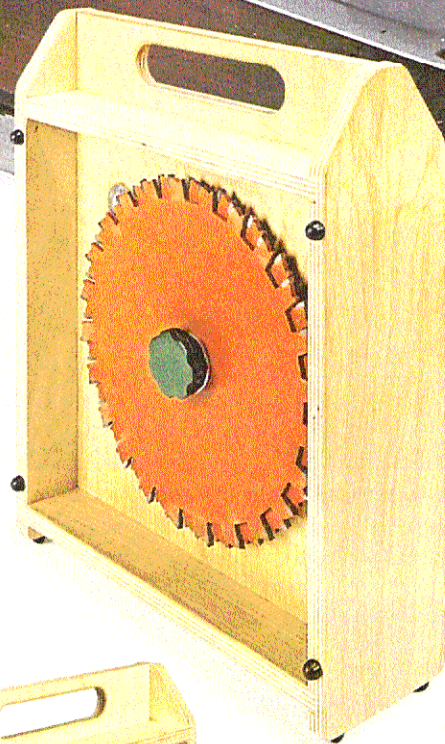

One side of the storage case holds chippers and shims and the other holds scoring blades.

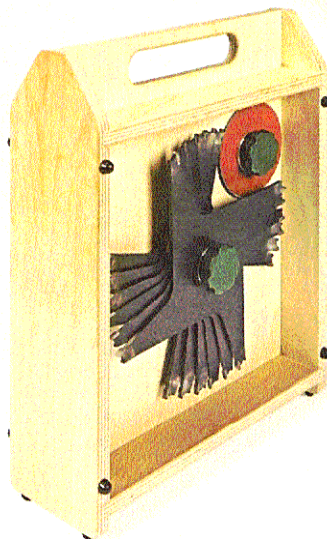

After cutting the pieces to size, I put the dado blade on my table saw and cut the dados in the sides for the bottom and two top pieces. I cut a groove right down the middle of each side to hold the *center panel* (C). Using the same setup, I cut the groove in the bottom.

Next, the bottom corners were rounded and the top edges mitered to eliminate the sharp corners.

With the sides and bottom complete, I turned to the center panel. The main work here is making a rounded cutout at the top of the center panel to create a comfortable handle (see Shop Tip below). Then holes were drilled for the coupling nut that holds the two scoring blades and chippers, and for the T-nut that holds the shims.

The two *top pieces* (D) slip into the dados cut earlier. They are simply trimmed flush with the edges.

Hardware. Glue and a couple of clamps are all you need for the assembly. Once the case is assembled, a little bit of hardware that's available from most home centers will make it ready for use.

Rubber bumpers on the outside edges will help protect the case when banged around. I also added bumpers to the inside of the case to lift the scoring blades and chippers off the center panel, making it easier to get them out.

The $\frac{3}{8}$ " coupling nut was a tad too large for the scoring blades and

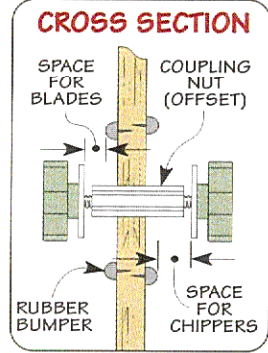
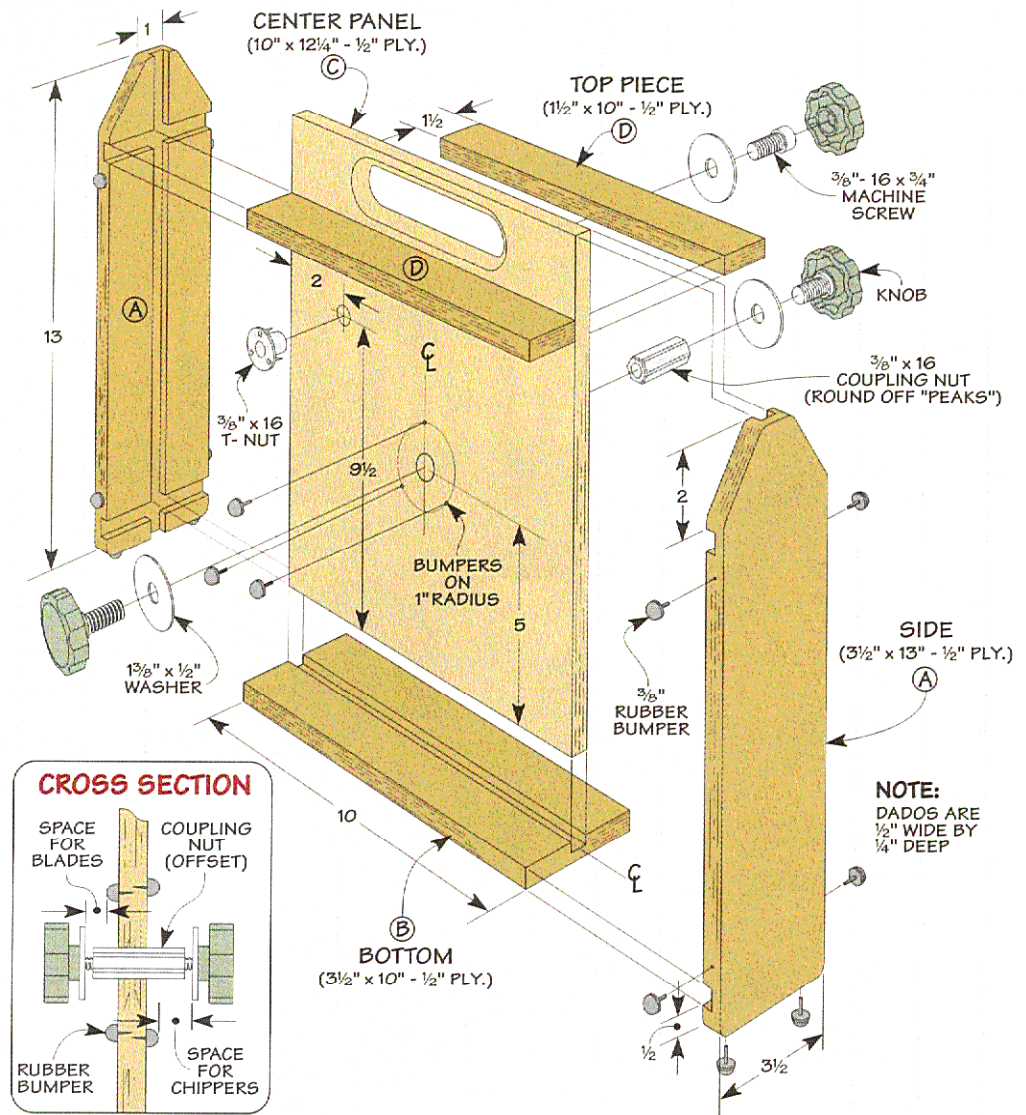

chippers to fit over it. So sand off the "peaks" just enough so it will fit the arbor holes in the scoring blades and chippers. Since the chippers take up more space than the scoring blades do, the coupling nut is offset to the chipper side of the case (see Cross Section above). Epoxy will

hold both the T-nut and the coupling nut in place. I added knobs to the machine screws for the coupling nut to make them easier to tighten and loosen.

Now I have a convenient place to keep my dado blade and all of its accessories handy.

Making the Handle

Three tools were used to make the handle for the storage case.

First, after laying out the cutout at the top of the center panel, I drilled a hole at each end with a 1" Forstner bit. Then I used a jig saw to remove the waste and sanded the edges smooth.

Finally, to make the handle more comfortable, I routed the sharp edges of the cutout with a $\frac{1}{4}$ " roundover bit.

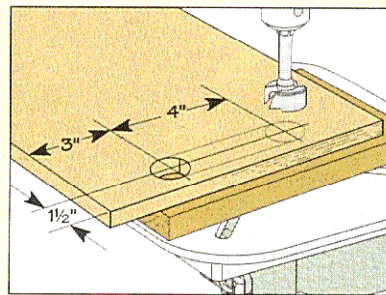

▲ **Set the Boundary.** Use a 1" Forstner bit to cut a hole at each end of the handle.

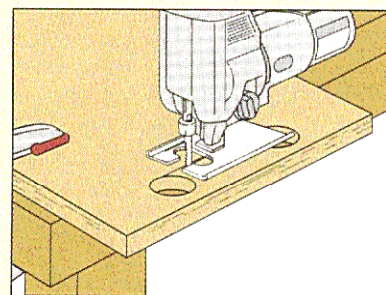

▲ **Remove the Waste.** A jig saw is the best tool to remove the waste for the handle in the center panel.

fine tools

brass-body

Hand Plane

This fine tool is beautiful to look at and a joy to use. But the greatest satisfaction comes from knowing that you built it yourself.

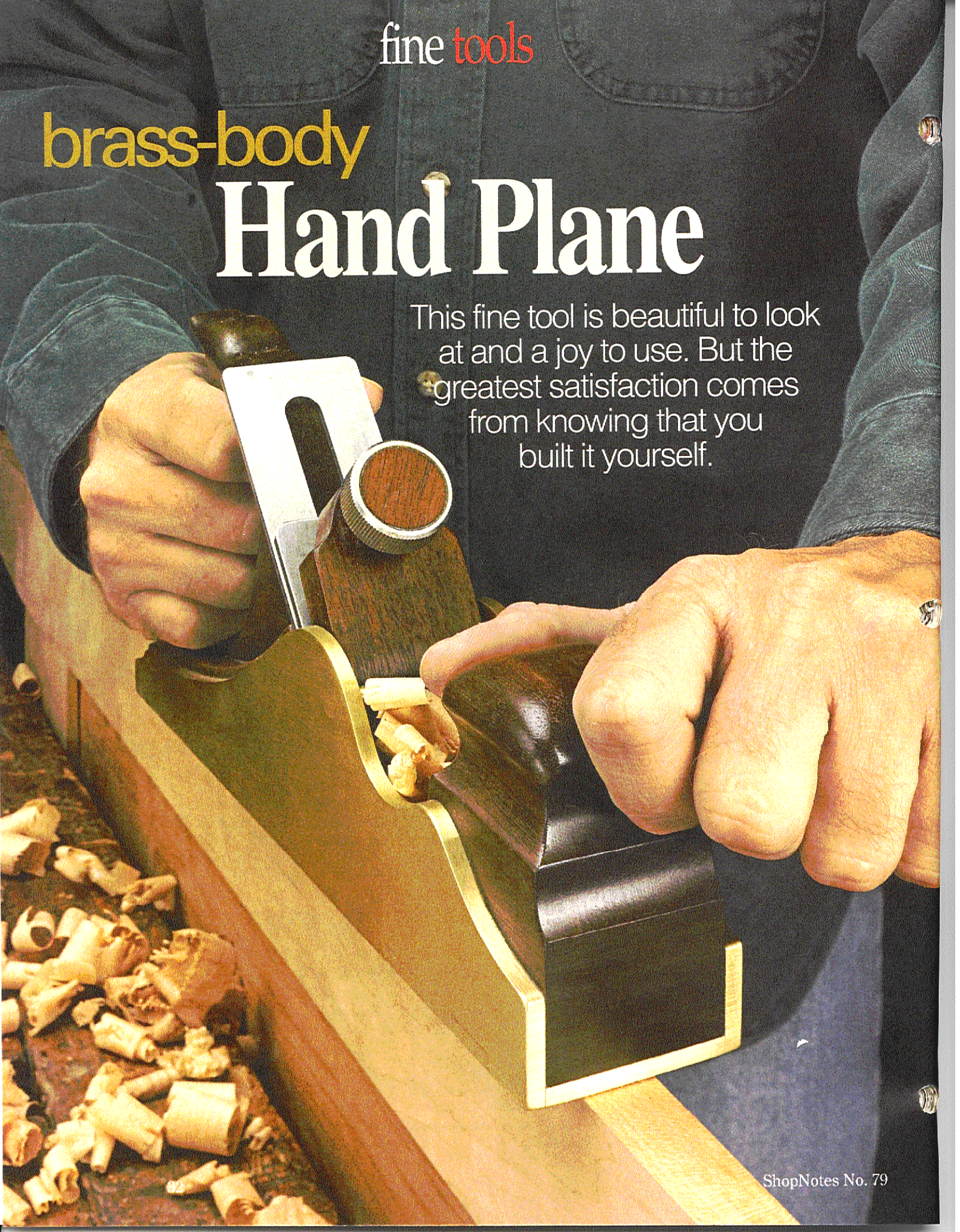

Exploded View Details

OVERALL DIMENSIONS:
2¼"W x 5⅝"H x 11⅞"L

NOTE: SIDES AND SOLE OF PLANE ARE MADE OUT OF ⅜"-THICK BRASS

NOTE: TOTE HANDLE IS SANDWICHED BETWEEN TOTE CHEEKS

NOTE: FOR MORE ON WORKING WITH BRASS, SEE ARTICLE ON PAGE 37

NOTE: SIDES AND SOLE OF PLANE ARE JOINED WITH SOLDERED BOX JOINTS

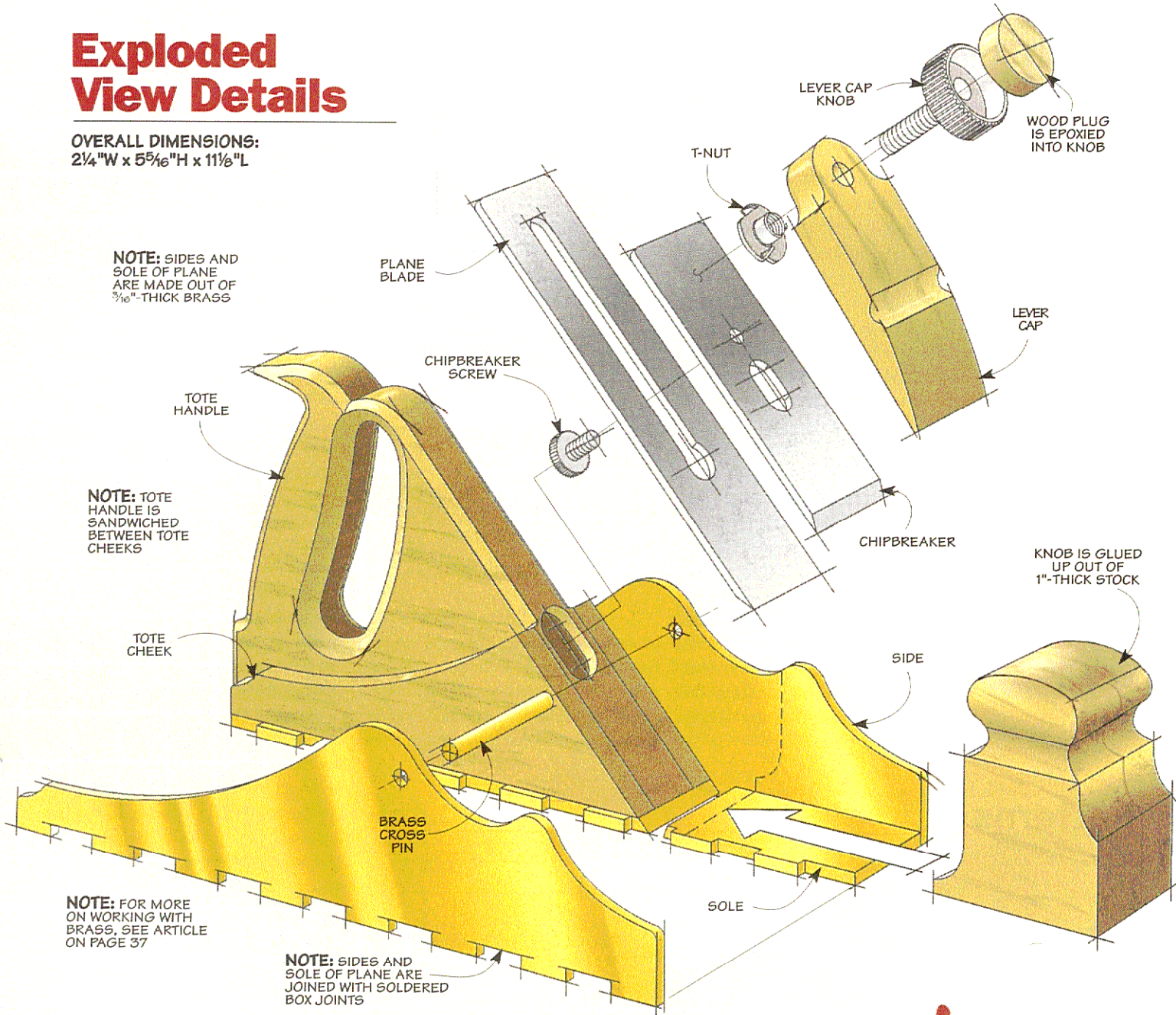

Hardware

- (1) ⅜" x 3" Flat Brass Bar Stock (3' long)
- (1) ¼"-dia. Brass Rod (2¼" long)
- (1) Stainless Steel Knurled Knob (⅝" threads)
- (1) ⅝"-dia. Threaded Rod (1⅜" long)
- (1) ⅝" T-Nut
- (1) 1¼"-wide Plane Blade
- (1) 1¼"-wide Chipbreaker w/screw

Bonus Plan!

Block Plane

As a companion to the plane shown on the opposite page, we've also designed a brass-body block plane. This plane is built using the same techniques that you'll learn about in this article — just on a smaller scale. To download free plans for making this bonus block plane, visit the Online Extras page on our website at:

www.ShopNotes.com



ShopNotes
GO ONLINE EXTRAS

building the Plane Body

The design for this plane is based on the British infill planes that became popular in the early 19th century. These planes typically had steel sides and soles that were joined together and then “filled” with a dense wood to serve as a handle and knob. The result was a solid plane with a lot of mass to help dampen vibration. Even today, infill planes are eagerly sought after by woodworkers and collectors alike. But they are also fairly expensive — which is all the more reason to build your own.

Brass Plates. The metal body of the plane is made up of three plates of $\frac{3}{16}$ ”-thick brass joined with box joints and then soldered together (Figure 1). I’ll walk you through the major steps here, but for more detailed information on working with brass, see the article beginning on page 37.

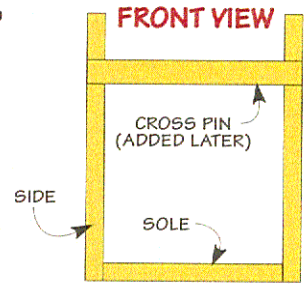
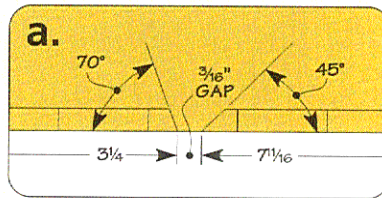
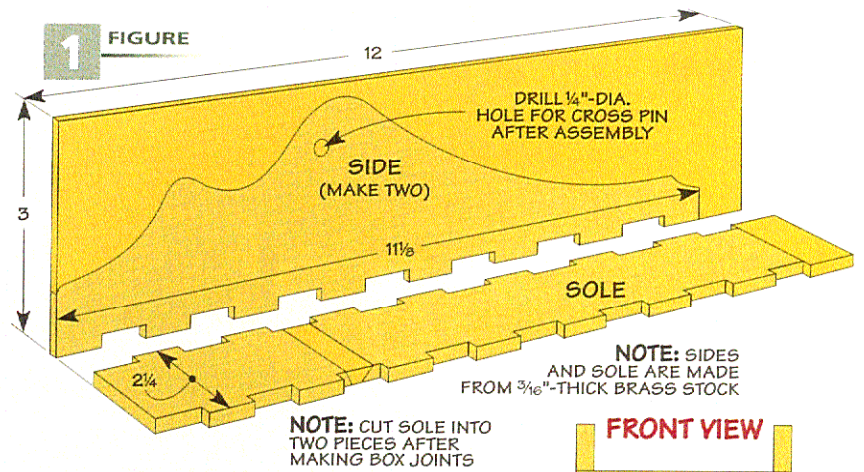

To start with, I cut all three of the brass plates about an inch longer than the finished length of the plane. This allows you to trim the pieces to exact length after cutting the box joints. I cut the box joints on

the table saw using a simple jig — pretty much the same way you’d cut box joints in wood. For more on making the box joint jig, see page 16.

Shaping the Sides & Sole. After cutting the box joints, you can cut the sides to shape using the pattern at left as a guide. You’ll also have to cut the sole into two pieces to create a throat opening for the blade.

There’s one thing to note here. If you take a look at detail ‘a’ above, you’ll see that both edges of the throat are beveled. But the *angle* of each bevel is different. The back edge of the throat is beveled at 45° to match the angle at which the blade will sit. The front edge of the throat is beveled at 70° to provide clearance for the wood shavings that you’ll make with the plane.

After cutting the sole into two pieces to create the throat opening, you can go ahead and solder the joints together. (Refer to the article on page 37 for more information on how to do this.)

Tote & Knob. Once you’ve cleaned up the solder around the box joints, you can start making the wood parts — the tote and knob. As you see in Figure 2, the tote is made up of three separate pieces. The 1”-thick handle is sandwiched between two cheeks of thinner wood.

Patterns

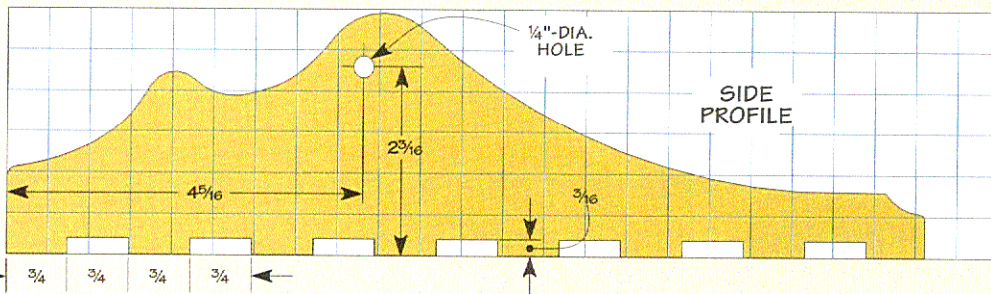

Note: All patterns are shown on a $\frac{1}{2}$ ” grid. To download full-scale patterns, go to www.ShopNotes.com.

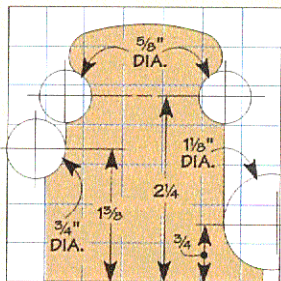
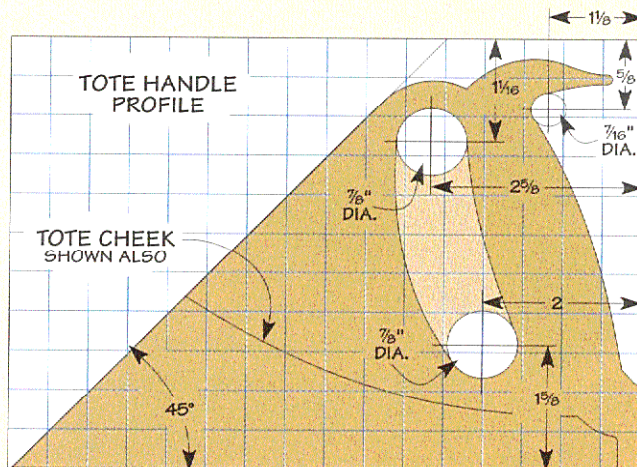

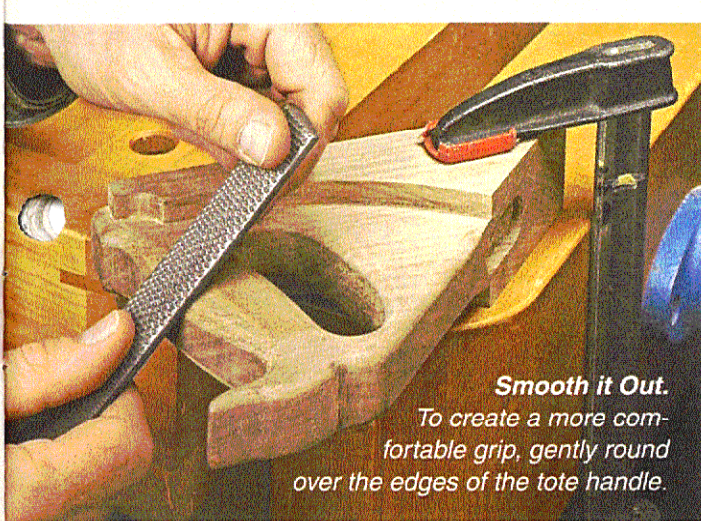

Smooth it Out.
To create a more comfortable grip, gently round over the edges of the tote handle.

2 FIGURE

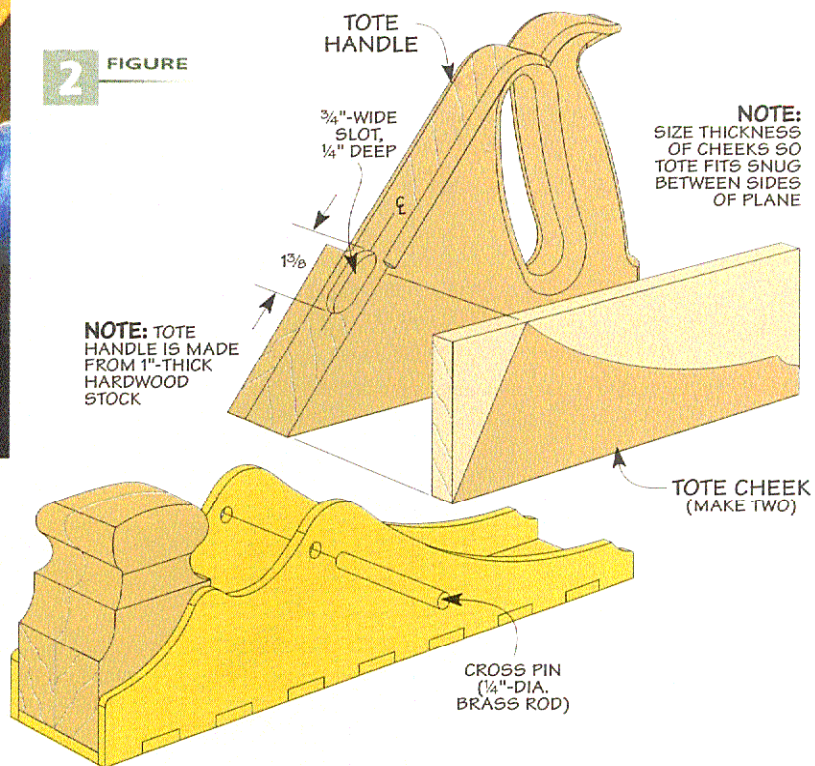

The front knob is also glued up. Patterns for the tote and knob are provided in the box on the opposite page. But one of the nice things about making your own plane is that you can custom fit these pieces to your own grip.

Cross Pin. Before adding the tote and knob to the plane body, I installed the brass cross pin for the lever cap, as you see in the drawing above. Again, there is more information on this in the article on working with brass on page 37.

Once the cross pin is in place, the tote and knob can be epoxied into the body of the plane. As you are doing this, check to make sure that the front face of the tote (where the

blade will rest) is flush with the beveled edge of the throat opening in the sole. Then after the epoxy is dry, you can scrape and sand away any squeezeout.

Making the Tote & Knob

Shaping the tote and knob is really just a matter of drilling and cutting away the bulk of the waste and then cleaning up the profiles by hand.

Handle. To make the handle for the tote, lay out the pattern on a piece of 1"-thick stock. Then to create the opening for your hand, drill a hole at each end (see first drawing at right) and cut out the remaining waste.

After cutting the profile of the handle, you can drill a couple of shallow, overlapping holes along the front edge of the handle to provide clearance for the chipbreaker screw. Finally, the exposed edges of the handle are rounded over.

Knob. Making the knob is even easier. A couple Forstner bits of different sizes are used to create the curved profiles on the knob as shown in the lower left drawing. Then finish the shaping with rasps, files, and sandpaper until the knob feels smooth and comfortable in your hand.

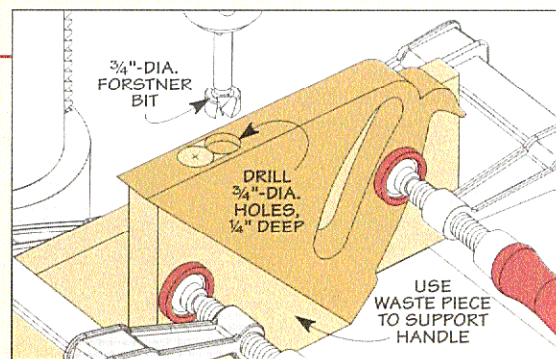
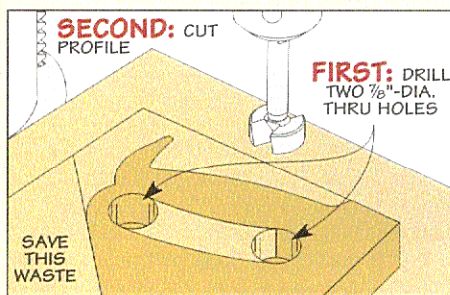

▲ **Shaping the Handle.** To make the handle for the tote, start by drilling and sawing out the waste for the hand opening. Then after cutting the profile of the handle, drill a couple of shallow holes to create a recess for the head of the chipbreaker screw.

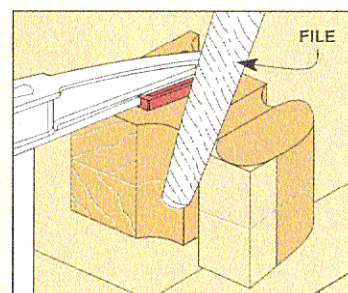
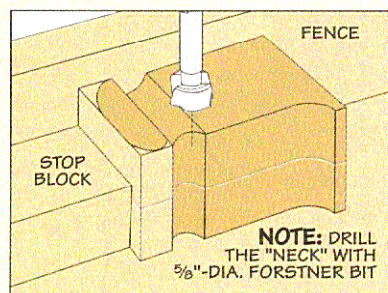
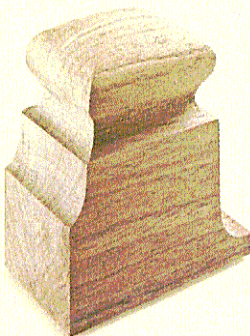

▲ **Shaping the Knob.** To make the knob, cut away the bulk of the waste on the band saw first. Then drill a 5/8"-dia. hole on each face to create the "neck." Finally, file and sand the knob to shape.

adding the Lever Cap

At this point, the only part of the plane left to make is the lever cap. This is nothing more than a hardwood wedge with a knob at one end. The cap slips underneath the cross pin in the body of the plane and sits on top of the blade assembly. By tightening the knob, the edge of the cap is forced down against the blade assembly, holding it in place. For more on making the lever cap, see the box below.

Knob. When it came to selecting the knob for the lever cap, I wanted something special to match the rest of the plane. So I chose a knob with a large recess in the center to hold a wood insert. The knob is also threaded for a stud. (I made my own stud out of a short piece of threaded rod.) After attaching the stud to the knob with epoxy, you can use a hole saw to make a round

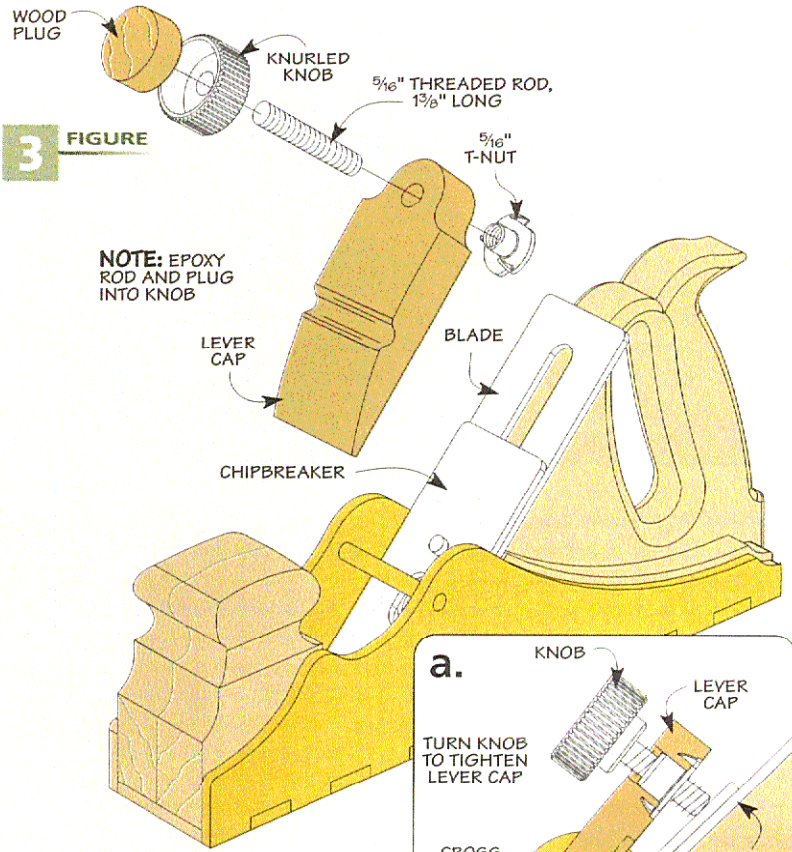

▲ **Lever Cap.** The blade and chipbreaker are held in place by the lever cap.

plug for the knob. (I selected a wood to match the knob and tote, but you could choose a contrasting wood.) Now all you have to do to complete the plane is add a blade and chipbreaker. For more information on the blade and chipbreaker I selected, see sources on page 51.

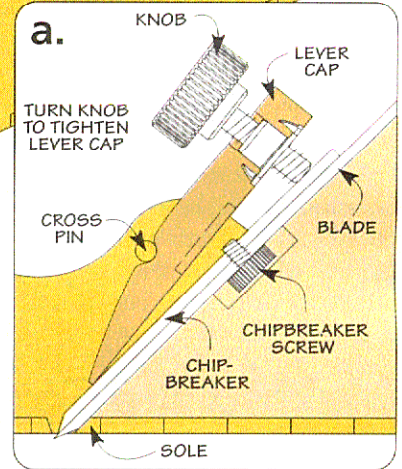

Making the Lever Cap

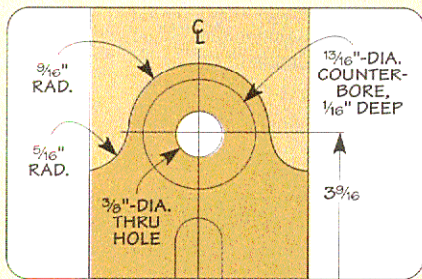

If you take a look at the photo above, you'll see that the lever cap is tapered like a wedge. But the trick to making the cap is to start with a square blank and drill all the holes first. After this is done, you can cut the blank to shape.

Start by drilling a counterbored hole for the T-nut (see drawing at left). Next, drill a series of shallow, overlapping holes to create a slot in the back of the cap. This slot will provide clearance for the chipbreaker screw.

To create the rounded groove in the front of the cap for the brass pin, drill a hole through the edge of the blank, as you see in upper drawing at right. Finally, cut the cap to final shape on the band saw and add the T-nut to the back.

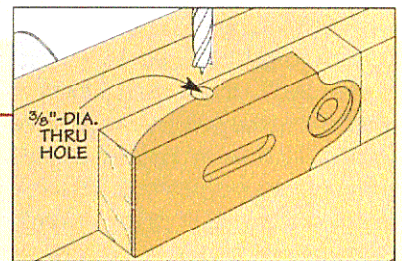

▲ **Drilling.** To create the groove for the brass pin to rest in, drill a hole through the edge of the blank.

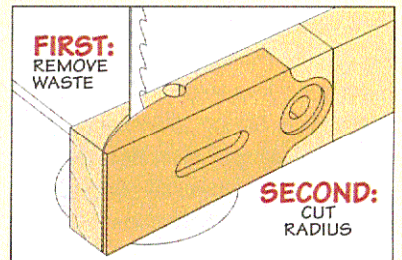

▲ **Cut to Shape.** Using a band saw, cut the cap to shape and sand the edges smooth.

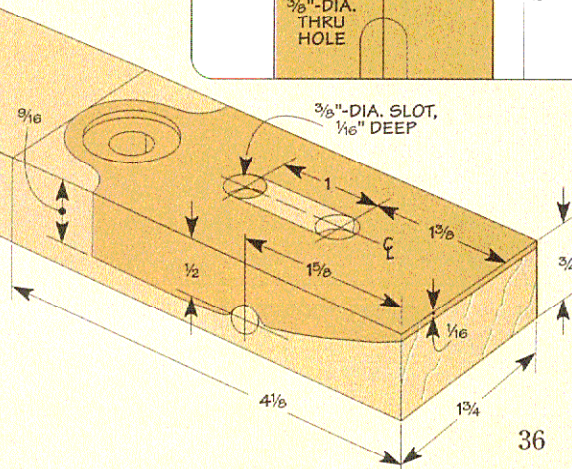

working with **Brass**

Learn some simple techniques for working with this useful and attractive metal.

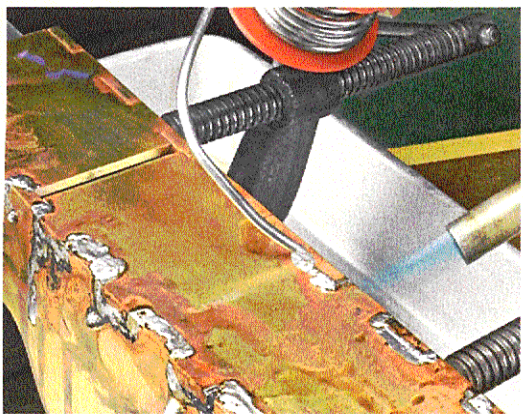

▲ **Soldering.** One of the keys to successful soldering is to heat the metal until the solder just begins to flow into the joints.

If you've never done much metalwork, the thought of making the brass-body plane on page 32 might seem a little intimidating. But with the exception of the soldering (more on that later) most of the techniques we used for working with the brass are similar to woodworking techniques you're probably already familiar with.

Brass. Traditionally, infill planes like the one in this issue were made out of steel. But because steel can be difficult to work with, we decided to use brass for the sides and sole of the plane.

Now there are several types of brass available, some much harder than others. I chose a soft, free-cutting brass that machines easily with standard woodworking tools. The only thing you'll need is a special carbide blade for cutting non-ferrous metal on your table saw. (For more information on the brass and the saw blade I used, see Sources on page 51.)

I also bought a $\frac{3}{16}$ " 10-tpi band saw blade for making the scroll cuts on the sides of the plane. This is just a standard wood-cutting blade, but it works fine for cutting brass.



Cutting Box Joints. A simple jig and a metal-cutting saw blade allows you to cut the shallow box joints on your table saw.

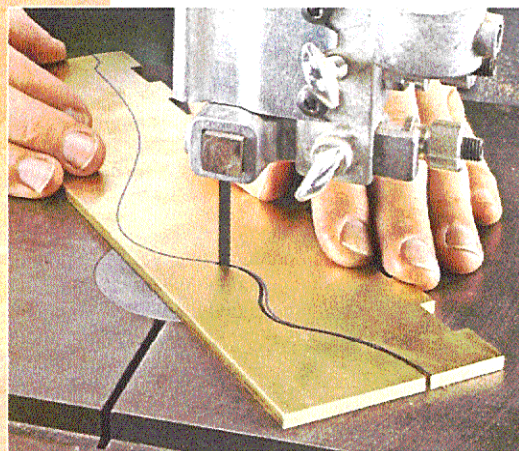

▲ **Side Profiles.** To make the scrolling cuts on the sides of the plane, I used a 10-tpi (teeth per inch) blade on my band saw.

Cut, Solder, and Sand

The first step in making the body of the plane is to cut the box joints that join the sides and sole of the plane.

To do this, I made a special jig for my table saw — similar to the kind of box joint jig you would use when working with wood, see photo above. For more on making and using the box joint jig, turn to page 16.

The saw blade left some small ridges, particularly in the corners of the box joints. So I lightly filed each notch until they were smooth and the pieces fit together.

Profiles. After cutting the box joints, the next step is to cut out the profile for the sides of the plane (see the pattern on page 34). With a sharp blade, the band saw cuts through the brass like a hot knife through butter, see inset photo above. Once the sides and sole of the plane are cut to size, you're ready to join the pieces.

SOLDERING

With box joints in wood, you would use glue to hold the pieces together. But since these box joints are cut in brass, you'll need to solder the joints together. If you've ever "sweated" a copper pipe fitting, this will be

pretty easy for you. But if you are new to soldering, there are a few things to keep in mind.

Equipment. To start with, you'll need a small propane torch, some 60/40 solder, a can of flux, and an igniter (or some matches) to light the torch, see photo in margin at left.

Once you've got all the supplies together, you're ready to go. The key to any soldering job is to make sure all the mating surfaces are clean and free of any oil or grease. (Otherwise, the solder won't

stick.) So take a few minutes to clean and lightly sand the surfaces of the brass pieces. Then brush some flux onto all the mating surfaces of the box joints. (The flux will be easier to brush on if you soften it with the torch for a few seconds.)

Next, you'll need to clamp the sides and sole of the plane together while you solder the joints. To do this, I made a spacer out of a block of wood and some aluminum angle to fit between the sides of the plane (photo below). The aluminum

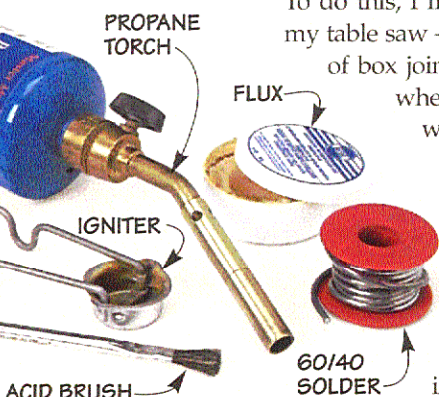

▲ **Supplies.** The equipment you'll need for soldering the box joints can be found at most hardware stores.



Soldering. The box joints are soldered to create a strong, long-lasting joint that's practically invisible.

covers the wood and prevents it from charring and possibly igniting while you're soldering the joints.

When you put the spacer block in place, make sure it isn't touching the sole of the plane — there needs to be some space for the solder to flow through the joint. You also want to make sure that the clamps you use to hold the pieces together don't have any plastic or rubber parts that will melt during the soldering process. Finally, once you have the pieces clamped up, check that the sides are square to the sole.

The trick to soldering is to heat the metal (not the solder) just enough to make the solder flow. Move the flame back and forth along the box joints to heat the metal evenly. Since the brass acts as a heat sink, it will take a while to get the metal hot enough to make the solder flow. So be patient.

Once the metal is hot enough, capillary action will draw the solder into the crevices between the box joints. After you've soldered all the joints, let the metal cool down. (This will take awhile.)

CLEAN UP

At this point, the plane body will look pretty ugly. But the next few steps will take care of that. Start by washing the plane in some soapy water and drying it off.

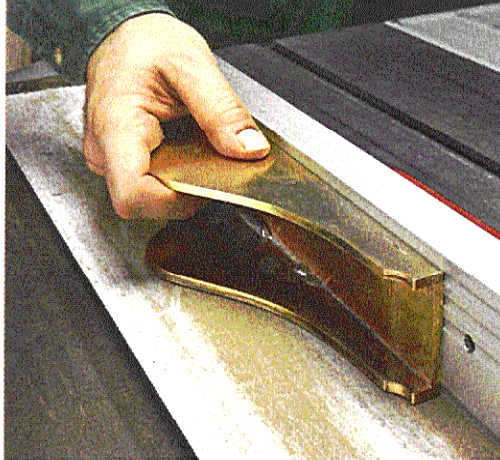

▲ **Square it Up.** To clean up the outside of the plane and square the sides with the sole, place a piece of adhesive-backed sandpaper on the top of your table saw.

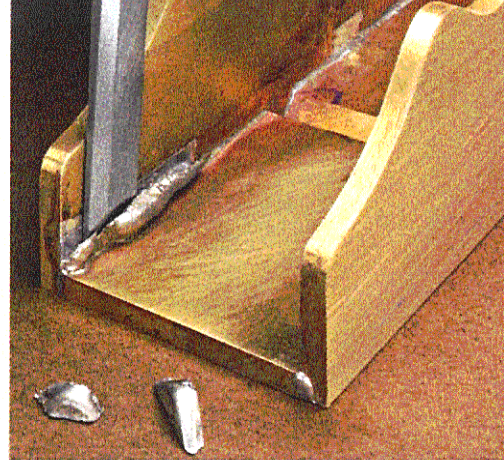

▲ **Cleaning the Inside.** An old chisel comes in handy to remove any globs of solder from inside the body of the plane. Then you can scrape or sand away any remaining traces.

The next step is to sand the body of the plane on a flat surface, as you see in the upper left photo. This does two things. First, it removes the excess solder from the outside of the plane. And second, it trims the ends of the box joints so they wind up flush with surface.

I sanded the bottom of the body first. Then, to sand the sides square with the sole of the plane. To clean up the inside, I used an old chisel to remove the globs of solder on the inside of the box joints, see upper right photo. I sanded the inside by hand.

Cross Pin. The last bit of machining to do is to add the brass cross pin for the lever cap. This is simply a matter of drilling a hole

through the sides of the plane as shown in the lower left photo. To prevent the sides from flexing while drilling the holes, I made a spacer to fit inside the plane.

The cross pin is just a piece of brass rod. Cut the pin a hair longer than the width of the plane and insert it into the holes. To rivet the pin in place, set the plane on an anvil or metal surface. (I used my bench vise.) Then peen over the ends of the pin with a hammer, as you see in the lower right photo. Finally, file and sand the ends of the pin flush with the sides.

Lacquer. To keep the brass bright and shiny, I applied a coat of spray lacquer. But it's best to wait to do this until after you've added the knob and tote. 🛠️

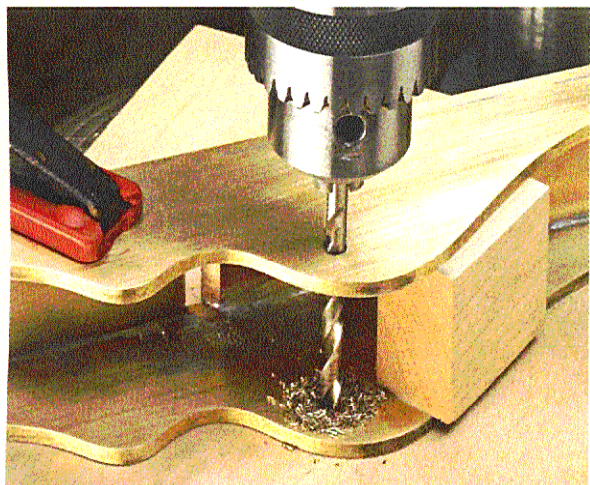

▲ **Drill the Holes.** With the body of the plane clamped in place, drill the holes through the side for the cross pin. A spacer block prevents the side of the plane from flexing while you drill the holes.

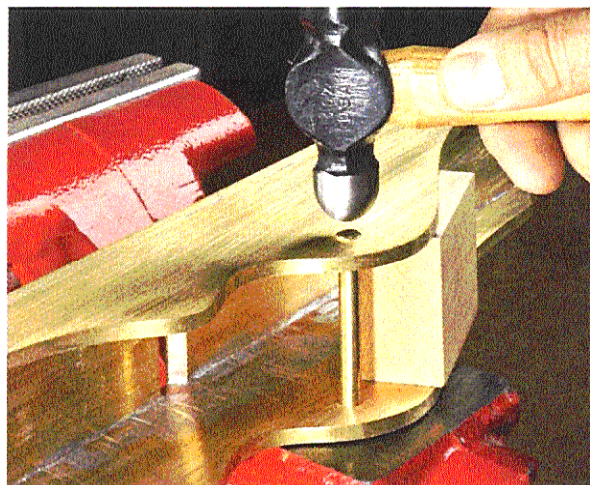

▲ **Add the Pin.** Cut the brass rod for the cross pin a hair longer than needed and peen the ends over with a hammer. Then file and sand the ends of the pin flush with the surface of the sides of the plane.

handy and hardworking

Rotary Tools

Find out why they're a "must-have" addition to any workshop.



■ I owned my first rotary tool for over 15 years. (And it was 10 years old when a neighbor gave it to me.) But it lacked a few features I needed — like variable speed — so I thought it was about time to upgrade to a new one. The timing couldn't have been better.

That's because *Dremel* recently introduced a new tool to their line, the 400 XPR, that I'm pretty excited about. Thanks to a more powerful motor and some new attachments

and accessories (like a mini-planer, a multisaw and a plunge base), this compact, ergonomically-designed rotary tool now handles all kinds of "woodworking" jobs that it couldn't handle before.

Fast and Powerful. It's speed, not brute force, that make these tools work so well. The *Dremel* 400 XPR has variable speeds ranging from 5,000 to 35,000 RPM. At those speeds, the tool does all the work. All you need to do is guide it.

But unlike older rotary tools, the 400 XPR has a new permanent magnet motor. Permanent magnets allow the motor to better sustain performance at all speed settings, especially in the lower speed ranges around 5000 RPM. This means the tool won't stall under load as easy as a wound motor will.

New Innovations. In case you're wondering, the 400 XPR is still compatible with all the old attachments and accessories that have been around for years. But as I mentioned, it can also be used with a couple of interesting brand new attachments (as well as a few others that have come out in the last few years) that could very well change the way you work in your shop and around the home.

XPR Planer. One of these new attachments is the *XPR Planer*, which is included with the 400 XPR along with a molded plastic carrying case. This mini-planer features a high-speed steel (HSS) spiral-style bit that takes off only 1/64" per pass. You can use it to plane down sticky doors up to 2 1/4" wide (see the photo at left). Or close

Mini-Planer. ▼ One of the most interesting new innovations for rotary tool users is this hard-working, mini-planer attachment.



up a loose miter with the planer by taking off a super-thin shaving.

The planer can also be used to cut chamfers. To do this, just tilt the tool 45°. A bevel at the end of the planer's edge guide supports the cutter for perfect chamfers.

XPR Multisaw. The XPR Multisaw (available separately or as part of a kit) turns a rotary tool into a handy jig saw capable of cutting through 1½"-thick stock. The Multisaw uses standard size "U" and "T" shank jig saw blades and its pivoting base makes the saw work a lot like a miniature reciprocating saw (see photo below).



Plunge Base. The plunge base shown at the top of page 40 is another accessory that makes a rotary tool more useful by turning it into a mini-plunge router. Its large, clear base provides increased visibility and measures 5½" wide, making it very stable. Used by itself, the wide base makes it handy for routing signs and inlays. I've also used mine for routing parallel to an edge with the edge guide.

Router Bits. To go along with the plunge base, a variety of HSS router bits with ⅛" shanks are available. They include a V-groove, core box, and three different sized straight bits for freehand routing. Bearing-guided bits for routing beads, round-overs, and chamfers are also available. I even have a small key-hole router bit for cutting slots.

Flex Shaft. One old attachment, the flex shaft extension, has also been improved (photo above right). The new flex shaft has a metal core wrapped in durable plastic that bends to a 5" radius. It connects a small handpiece to the rotary tool. The handpiece is about the size of a pen allowing for fingertip control and increased comfort.

◀ **Multisaw.** This combination jig saw/reciprocating saw uses standard "U" and "T" shank blades.

▲ **Flex Shaft.** An all new cable design (it now bends to a 5" radius) provides more flexibility during use.



◀ **Pen-size Handpiece.** The small size makes it ideal for hard-to-reach places and fine control.

A wide variety of accessories can be used with the flexible shaft for rough shaping, smoothing, and cutting in a wide range of materials from wood to plastic to rubber.

Alternate Uses. Rotary tools are also great for a lot of handy applications around the home. (For more on one of these applications, see the box below.)

So as you can see, even though rotary tools are small in size, they can be a powerful addition to your shop arsenal. And now that you know a little bit more about their many uses, it's easy to understand the benefits to owning one. 🛠️



▲ **Plunge Base.** The plunge base and a clear plastic sub-base provide great visibility for routing out hinge mortises.

Outside the Shop: Razor Sharp Blades

Sharpening the blade on my lawn mower is one of those tasks that I always seem to put off. But mower blades (and most garden tools) need to be sharp to work at top efficiency. Dremel has a simple attachment for rotary tools that makes getting these blades in tip-toe shape a real snap.

Sharpening Stones. When used with an aluminum oxide sharpening stone, this comfortable, two-handed attachment works with any of Dremel's rotary tools.

The attachment provides the optimum angle to sharpen most lawn mower blades, as well as shovels, shears, and hoes.

Sharpening. Special sharpening stones and an angled attachment make sharpening garden tools and lawn mower blades a snap.



SETTING UP Shop

the best place for your Table Saw

Locating this essential tool will go a long way toward making your workshop more efficient and enjoyable.

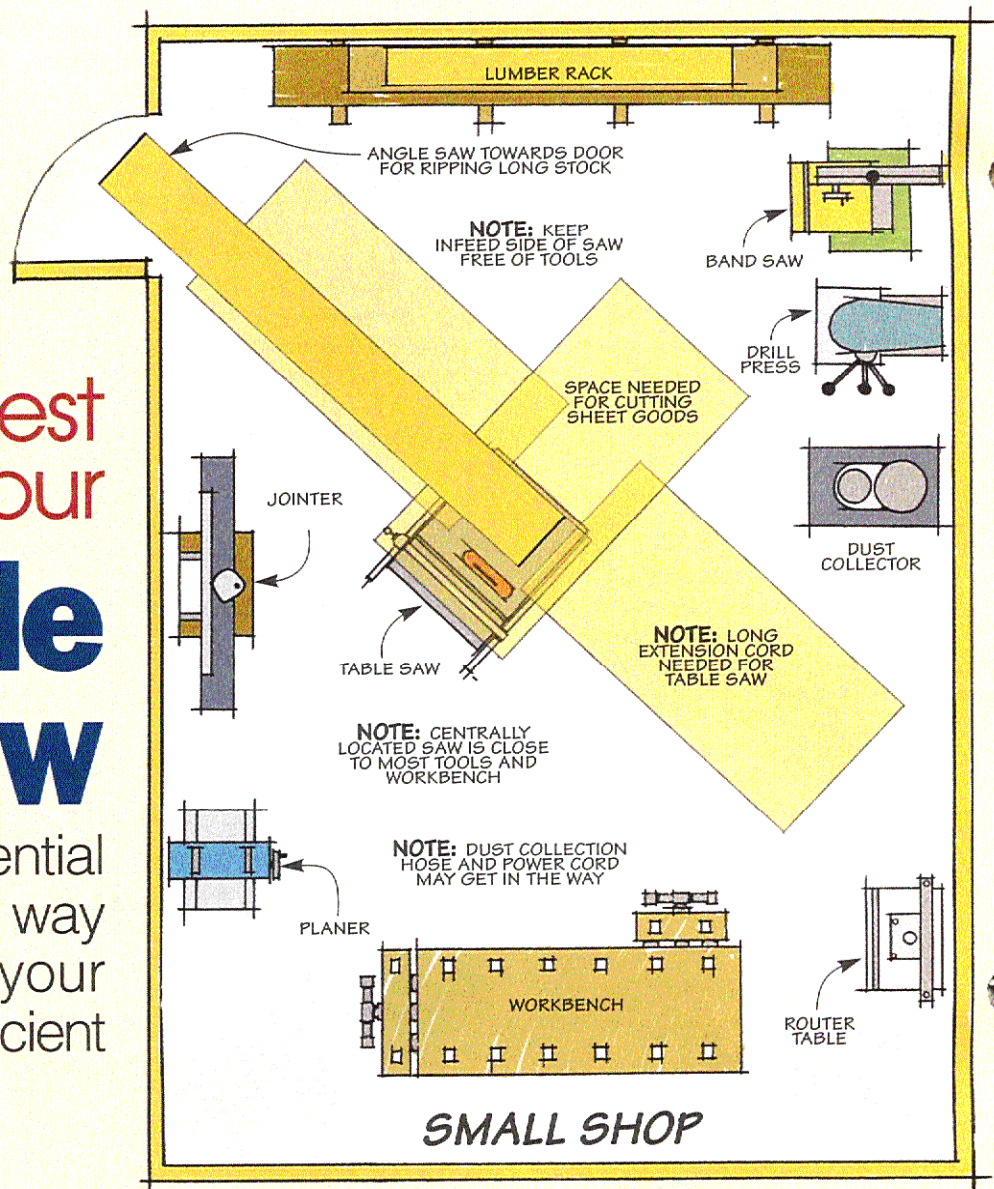

■ When it comes to power tools, the table saw is king in my shop. It's used for everything from breaking down sheets of plywood to cutting joinery. So finding the best place for this tool can have a big impact on how well your shop works.

Shops come in all shapes and sizes. But there are a few strategies you can use to help you find the best place for your saw. The result will be getting the most from your saw and maximizing shop space.

Finding the Space. The first thing to think about is how much space you'll need. Table saws take up a lot of space. I'm not just referring to the size of the saw. The drawing above shows what I'm talking about. The amount of space

a saw needs depends on the size of the stock you're using. For example, cutting full sheets of plywood and other sheet goods means you'll need to allow about 9-10' in front of and behind the saw to work safely. That's a big chunk of space.

Placing Other Tools. Where you place the table saw can affect other tools in your shop too. For starters, I try to keep my workbench near the saw. Since you'll spend a lot of time using both, you can save some steps (and work more efficiently) by positioning the workbench close to the table saw.

Other tools I like to keep close to the saw are the jointer and planer. These three tools see quite a bit of action at the beginning of a project

when I'm sizing stock. Just make sure that any tools on the outfeed side are set at the same height or below the height of the saw table, like the jointer you see in the drawing on the opposite page. This will prevent a workpiece from hanging up in the middle of a cut.

The drawings shown above and on the opposite page show two ways to apply these ideas to common shop floor plans.

SMALL SHOP

In small shops, I've found the best place to locate the table saw is smack dab in the middle of the room, like you see in the drawing above. There's a simple reason why this works so well. In this position, the

saw has the most room all around it to handle just about any size workpiece. It also means the saw isn't very far from other tools.

If your shop space is small, you can make the room work "bigger" by angling the saw. This lets you take advantage of the longer diagonal dimensions of the room.

Another way to maximize space is to position the infeed side of the saw near a door so you can "borrow" space from another room when ripping long stock.

Making it Work. Setting up the saw in the middle of the shop sounds like a great idea. But there are some other things you'll need

to think about — power, lighting, and dust control to name a few.

Adding another light shouldn't be difficult. But the power cord for some saws may not reach to the wall, so you may need to buy (or make) a longer one. But that means the power cord (and dust collection hose) may trail across the floor and get in the way occasionally.

NARROW SHOP

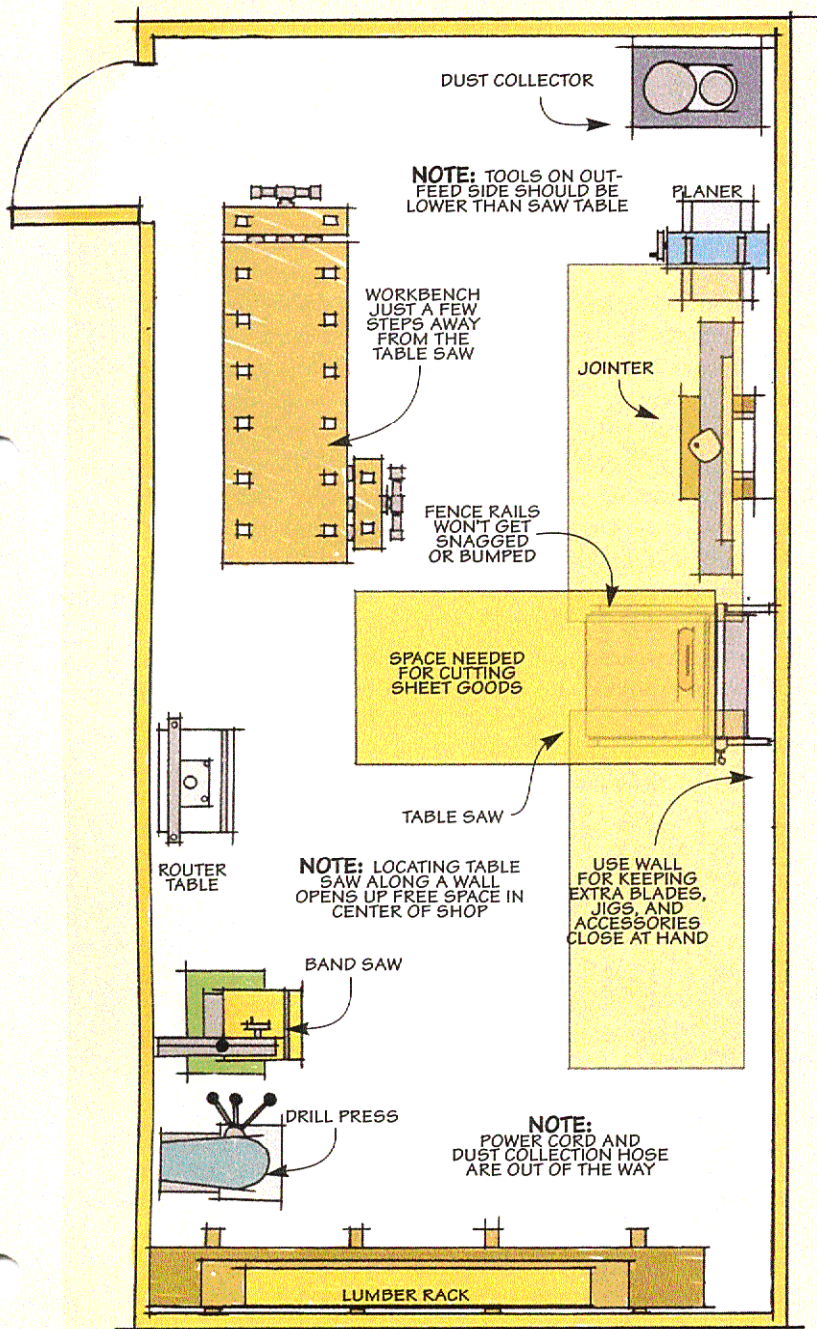

NARROW SHOP

In a workshop that's long and narrow, I recommend taking a different approach. Instead of putting the table saw in the middle of the floor, set it against one of the long walls, as you can see in the drawing at left. When you think about it, putting the saw against the wall makes a lot of sense.

With the saw in this position, you aren't limiting the capacity of the saw because you can't set the fence past the end of the rails anyway. Positioning the saw on a long wall gives you plenty of space for handling large workpieces. And it opens up the center of the workshop for assembly space and easier traffic flow.

Added Benefits. There are a couple other benefits of placing the table saw this way. The first is you can use the wall next to the saw as a handy place to keep extra blades, jigs, and accessories close at hand. This can save time and a few extra steps when changing the setup.

A second benefit you'll notice is that the saw's power cord will have a shorter run to the wall (and be out of the way). The dust collector hose can run along the wall as well.

Change Your Shop. To help you get started putting your shop in order, take a look at our website www.ShopNotes.com to find scale drawings of common shop tools. With a floor plan of your shop and these tools, you can rearrange the tools and worksurfaces in your shop until you find one that works without having to actually move the tools around. 🛠️



Use the scale tool drawings on our website ShopNotes.com to help lay out your shop

3 easy ways to **Cut a Rabbet**

Choose the best technique and cutting rabbets on the table saw will be a breeze.

There aren't many projects I tackle that don't involve cutting at least a couple rabbets. Now the old saying goes, "There's a right way and a wrong way to do everything." For the most part, you can't argue with that. But I'll add that sometimes there's more than one right way to do a job. And that's the case with cutting rabbets on the table saw.

QUICK AND EASY

At certain times, I'll use a really simple approach to cutting rabbets on the table saw. This just involves making multiple passes across the blade. I'll give

you a couple examples of when this method might be the best way to handle the job.

Narrow Workpiece. The left drawing and detail below show a quick way to cut a rabbet across the end of a long, narrow workpiece using multiple cuts. Here, the rip fence is set up as an end stop to set the width of the rabbet. And the miter gauge is used to feed the workpiece square to the saw blade.

The setup is pretty simple. The distance between the fence and the outside edge of the blade will give you the width of the rabbet. The

height of the blade gives you the depth. It's hard to hit the blade height dead on, so I like to start with the blade set a bit low and then sneak up after the first pass.

Once you're set to go, the first pass is made with the workpiece butted up against the fence. This pass will give you a clean, square shoulder. And after making any necessary adjustments, you can start nibbling away the remaining waste. Just back the workpiece a little further away from the fence after each cut until you reach the end (left detail drawing).

Closely overlapping saw kerfs will give you a pretty smooth bottom. But for an even smoother surface, I follow up with a simple trick. Just use the miter gauge to support the workpiece as you slide it sideways across the blade at several points along the rabbet. This will clean up any leftover ridges.

A Wide Panel. The right drawing and detail show a similar method you can use for large panels. The difference here is that you don't use the miter gauge but you will need to install an auxiliary rip fence on the saw.

Just as before, the rip fence is set so that the first pass cuts the

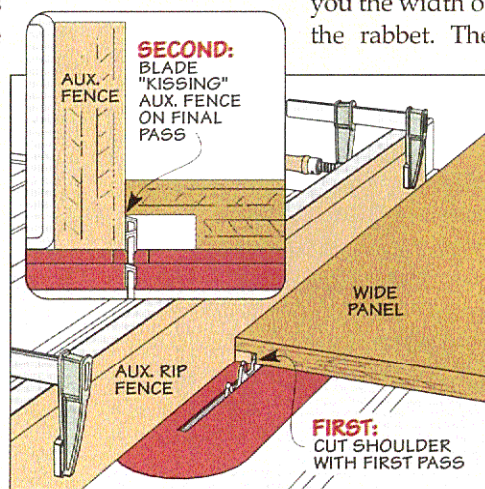
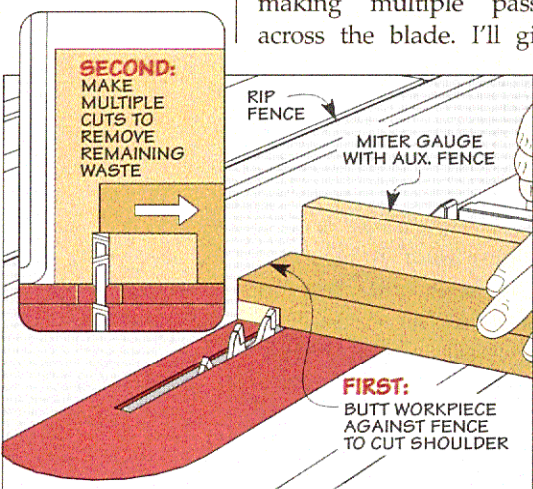

▲ **An End Rabbet.** Rabbeting the end of a narrow workpiece is simply a matter of nibbling away the waste with multiple saw cuts.

▲ **Wide Panel.** To rabbet a wide panel with multiple cuts, you have to slide the auxiliary rip fence toward the blade between cuts.

shoulder of the rabbet. Then, unlock the rip fence, give it a nudge toward the blade, and make a second pass. Just keep nudging the fence over and nibbling away at the waste. On the final pass the saw blade should be barely “kissing” the auxiliary fence.

TWO CUTS

A different technique works great for cutting a rabbet in the edge of a workpiece up to about 6" wide.

If you think about it, a rabbet is basically just a 90° notch. So creating a rabbet can be as simple as making two intersecting, perpendicular cuts. Using this “two-cut” method, you can get the job done quickly and accurately with minimal setup time.

The Tricks. The goal here is both to size the rabbet accurately and to make the cuts safely. There are just a couple of simple, but important, tricks to doing this.

Dado Blade A One-Pass Method

With a good dado blade on the table saw, cutting rabbets enters a whole different world. You'll find that rabbeting with a dado blade takes a little extra “setup” time, but afterward you'll zip through the cuts and the results can't be beat. It's my method of choice when a project calls for some “serious” rabbeting.

The Setup. A dado blade rabbeting setup is pretty straightforward. First comes the blade. A good stack dado set works best. It will give you a clean shoulder and a nice, flat bottom. Whenever possible, you want to put a “stack” on the saw that's slightly wider than the rabbet you're going to cut (right detail drawing). This allows you to cut the rabbet with a single pass. And then once the blade is installed, I like to cover it with a zero-clearance insert. The cut will be cleaner and the work safer.

Bury the Blade. The final piece in the setup is really the key. As you

The two drawings at right show the correct way to make the cuts. You want to start by making a clean shoulder cut on the face of the workpiece as shown in the first drawing. Just as before, the rip fence is set to establish the width of the rabbet.

The two cuts you make should create a sharp, square corner. So the height of the blade for both cuts has to be right on. I like to start with the blade set a tad low and then “tweak” it up.

The cut that removes the waste has to be made with the workpiece on edge. The right drawing shows the only *safe* way to do this. When the waste piece is cut loose, you

don't want it trapped between the fence and the saw blade. Chances are good it will be “kicked” back. The trick is to make the cut so the waste piece falls safely to the outside of the blade. This just means you'll need to set the fence to the width of the remaining piece as shown in the drawing.

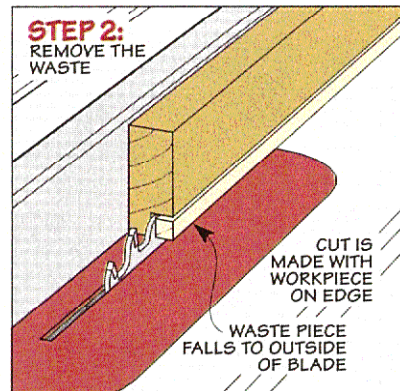
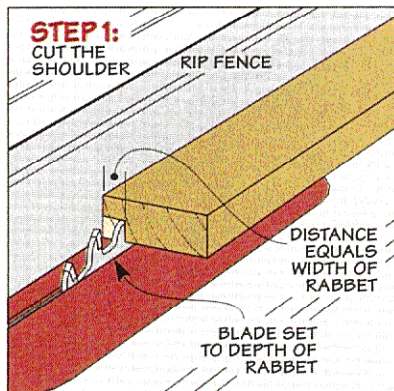

▲ **Two Simple Cuts.** Rabbeting the long edge of a workpiece is simply a matter of making two “perpendicular” cuts. First cut the shoulder to the inside of the blade, then remove the waste to the outside of the blade.

can see in the photo and the drawings, one edge of the dado blade is “buried” in an auxiliary fence clamped to the rip fence of the saw. You'll use this auxiliary rip fence to guide the cut and the dado blade will be free to cut right up to the edge of the workpiece.

The Cut. The great thing about rabbeting with a dado blade is that after the saw is set up, you're pretty much home free. Once you've set the fence by measuring to the outside of the blade, use the first workpiece to “sneak up” on the depth of the cut. When you're right on the money, give each workpiece a pass across the blade. Just apply good, downward pressure and you'll get quick, consistent results from one workpiece to the next.

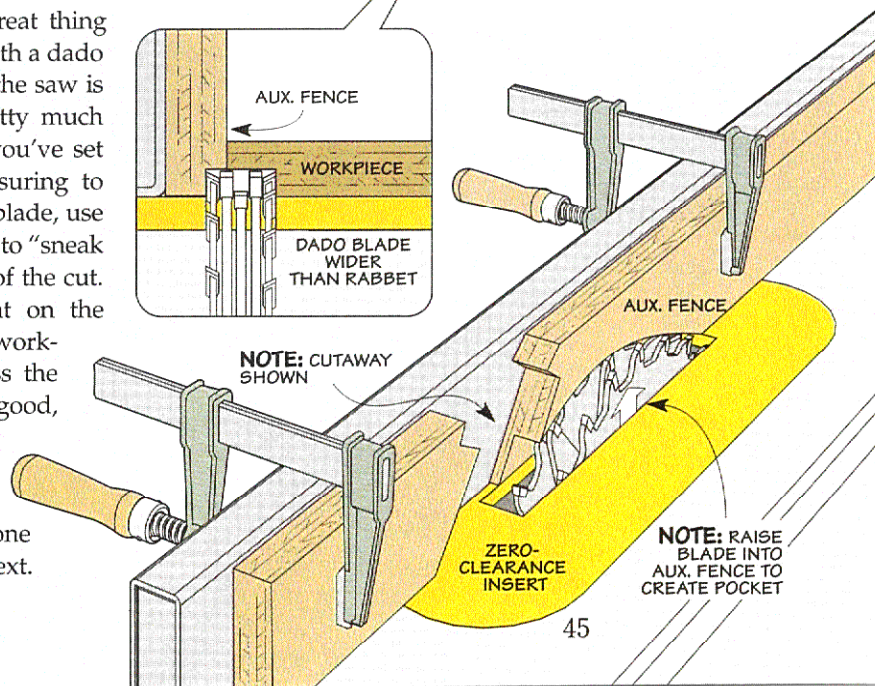
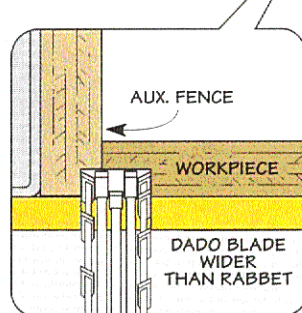
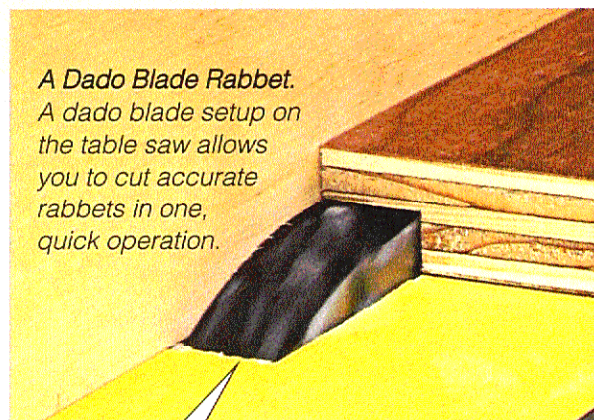

some extra storage space, making them perfect for these shelves.

A Size to Fit. Shelves are available to fit 2x4s or 2x6s on 16" or 24" centers. And if the spacing isn't quite exact, the shelves have a 1/4" clearance off the back and sides to allow for inconsistencies.

What surprised me most about these shelves was their heft. Made from 18-gauge galvanized steel (the same thickness as a pickup truck bed), a shelf can hold up to 45 pounds. The 5"-deep shelf is perfect for quart-sized cans. The 6 1/2" shelf is designed to hold gallon cans and jugs, while the 11" shelf can hold a 5-gallon bucket, like you see in the photo on page 46.

Versatility. Gaining previously unused storage space is reason enough to use the shelves, but I found their flexibility and easy installation even more beneficial. In a matter of seconds, I had shelves exactly where I wanted and needed them.

To help with spacing, I mounted the 11" shelf for my 5-gallon bucket, put the bucket on the shelf, and then mounted another shelf just above it, like in the photo on the opposite page.

Ah, but what if your shop doesn't have exposed wall studs? You can still take advantage of the shelves by building your own stud wall (see drawing below).

Plastic Bins. To help keep your shop neatly organized, plastic bins provide storage for small items, such as screws and nails. They come in different sizes, depending on the shelf, but are designed to fit the shelves three abreast. The bins are also stackable and come in various colors.

Stud Buddy has other accessories to further maximize your storage, including hangers for hoses and cardboard boxes designed specifically to fit the shelves. You can find a list of sources on page 51.



▲ **Plastic Bins.** You can get even more organized by using plastic bins to store screws and nails.

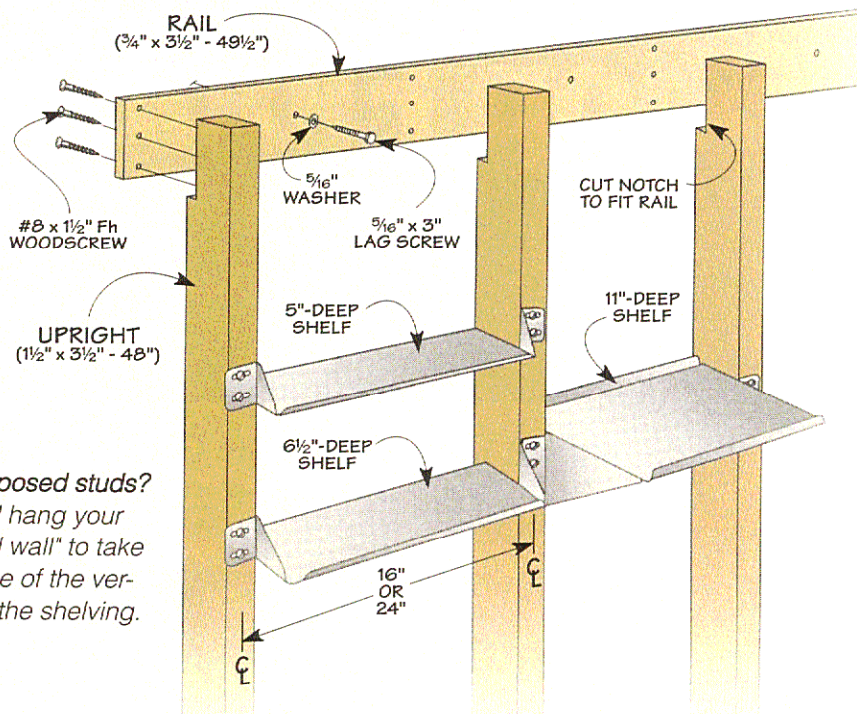

◀ **No exposed studs?** Build and hang your own "stud wall" to take advantage of the versatility of the shelving.

Easy Installation: Leveling Buddies

The hardest thing about installing any set of shelves is leveling them. The design of *Stud Buddy* shelves makes leveling and installing these shelves a one-man operation (near right photo). And the mounting holes are designed to overlap so that you can create a line of shelves (far right photo).



▲ **Leveling it Up.** Though not required, using a level when installing a shelf makes the task quick, easy, and accurate.



▲ **Aligning Multiple Shelves.** Clamp and level a straight 1x4 across several studs to quickly install a line of these shelves.

NEW Department!

ULTIMATE Garage



roll-out Shop Flooring

Give your garage or shop floor a brand new look in just a couple of hours — and without a lot of work.



▲ **Garage Floor Problems?** If your garage floor has pits, cracks, or unsightly oil stains, a roll-out floor covering may be just the solution you're looking for.

Let's face it. Unless you have a brand new garage, chances are that your garage floor looks a lot like mine — cracks, pits, oil stains — not a pretty site. And in the winter, it gets even worse. Vehicles track in snow and mud, leaving a big mess and making it almost impossible to keep the floor clean.

In the past, if you wanted a showroom finish for your garage or shop floor, your only options were difficult-to-use garage floor paints or epoxy coatings. But today there are simpler alternatives. One of these is a floor covering that rolls out over your existing concrete floor, just like you see in the photo above. These coverings can give your garage floor an instant facelift. And they also make it easy to keep your garage looking clean. All they need is an occasional sweeping. Or if they get really dirty, just hose them off.

But aside from the cosmetic benefits, there are other advantages as well. Made out of a tough, polyvinyl material, these floor coverings are resistant to the types of spills you're likely to come across in a garage — oil, antifreeze, brake fluid, battery acid, etc. They also provide a little cushioning, which is a big plus if you spend a lot of time

standing in your garage. And since the surface of these floor coverings has a textured pattern, they offer more traction than a bare concrete or epoxy floor, reducing your chances of slipping or falling.

Installation. But one of the biggest advantages of these coverings is the fact that they're so easy to install. All you have to do is sweep out your garage, unroll the flooring, and trim it to size. (See the box below for more on installation.) In fact, it's so easy that you can cover a standard two-car garage in just a couple of hours. Compare this with two or more days for prepping and applying an epoxy floor paint and you'll see why roll-out flooring is becoming so popular.

SELECTION

Roll-out garage floor coverings come in a variety of thicknesses, colors, sizes, and patterns. One manufacturer, *Better Life Technology* (BLT), offers two thicknesses of flooring material (see photos at right). The standard-grade thickness is 50-60 thousandths of an inch thick and comes in a ribbed pattern. The ribs are designed to help channel away water from melting snow and ice brought into the garage by your vehicle.

The commercial/industrial-grade flooring is 70-80 thousandths of an inch thick and comes in either the ribbed pattern or a "coin" pattern. Both thicknesses are available in six different colors — black, gray, tan, red, blue, or green. And they are sold in several standard sizes ranging from 7'x17' to 10'x25'. (Custom sizes are also available.)

If you want an even thicker floor covering, take a look at the "Gladiator" flooring by Whirlpool Corporation. At 90 thousandths of an inch, this was the thickest roll-out flooring material we could find. It comes in one style only — a diamond-plate pattern. (Whirlpool uses the same pattern on their line of garage storage cabinets and appliances.) Other than the thickness and pattern, the material used in this floor covering appears identical to the others we looked at.

Not Just for Garages. Although these floor coverings are designed for the garage, they can also be used in other parts of the house like basements, shops, or laundry rooms. If you plan to use them in a shop, there is one thing to be aware of. I noticed that rolling tools around became a little more difficult due to the added resistance of the covering. And the flooring had a slight tendency to buckle as I rolled tools over it. (But it laid down flat after awhile.)

Cost. You may be wondering how much these garage floor coverings cost. Compared to other flooring options, roll-out flooring is in the middle of the price range. At roughly \$2-3 a square foot, it's less expensive than most commercially applied epoxy coatings, but costlier than do-it-yourself floor paints.

But when considering the cost, keep in mind that you don't have to do a total "wall-to-wall" installation. You can cover as little or as much of the garage as you wish. And unlike garage floors that are painted on, if you decide to move you can just roll up the floor covering and take it with you. 🏠



Ribbed. ▶ The ribs on this flooring help to channel water and other liquids away, making it easier to keep your garage clean.



Coin. ▶ Available in commercial grade only, the raised circles on this flooring offer plenty of traction, even when wet.



Diamond Plate. ▶ Whirlpool's "Gladiator" flooring comes in a diamond-plate pattern.

Laying it Down: Fitting & Trimming

There's not much to installing roll-out floor coverings. Start by unrolling the flooring in your garage. (Ideally, it's best to let the unrolled flooring "relax" overnight.) Next, trim the flooring to fit, leaving about a 1/2" gap between the edge of the flooring and the wall for expansion.

To cover wide areas, overlap two or more sections of flooring, taping the sections together with carpet tape. You can also use carpet tape around the perimeter of the floor.



▲ **Trim to Fit.** Using a utility knife, trim the flooring to fit around any obstacles in your garage. Allow 1/2" of space for expansion.

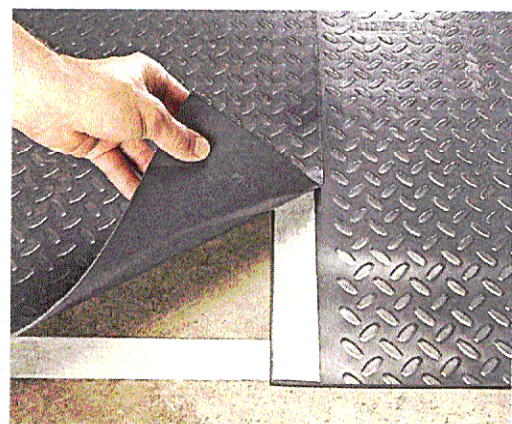

▲ **Tape the Seams.** For wide garages, overlap or butt two sections of flooring together and use double-sided tape at the seam.



questions from Our Readers

Snipe is a result of a deeper cut at the beginning and end of a board

solutions for Planer Snipe

Whenever I use my thickness planer it appears to make a deeper cut at the ends of the board than in the center part. What causes this and how can I stop it?

*Tom Holsinger
Avon, Minnesota*

■ When a planer cuts a little deeper at the beginning or end of a board, it is commonly referred to as “snipe.” The problem is usually due to the relationship between the feed rollers and the short bed of the planer.

If you look closely at your thickness planer, you will note that there are feed rollers on both sides of the cutter head. These rollers hold the workpiece flat against the bed as it passes through the planer.

At the beginning and end of a planer cut, only one roller is holding the workpiece flat against the bed. This can allow the end of the board to tip up into the knives of the cutter head, resulting in snipe.

Locking heads on newer planers have reduced some of this problem. But if your thickness planer doesn't have a locking head, here a few solutions to consider.

Bed Extension. An easy solution is to extend the support of the workpiece as it passes through the planer. You'll find that using a roller stand on either side the planer may help minimize snipe. This will keep the workpiece flat to the planer bed as it passes all the way through the planer.

Raise the End. Lifting the back end of the workpiece up slightly as it begins to pass into the cutter can also make a difference. A small amount of lift at the right time can help reduce snipe. Repeat the process as it leaves the planer.

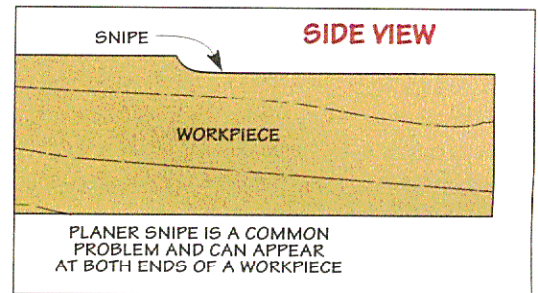

Use a Scrap Board. Another technique that can help is to butt a scrap board of the same thickness to each end of the workpiece as it's fed through the planer (drawing bottom left). This holds the rollers in position as the workpiece enters and exits the thickness planer.

Plan Ahead. When any significant thickness must be planed off in my shop, I always plan the passes so that the final passes will only remove a small amount of material. Since the last passes only remove a bit at a time, any snipe made will be small and end up being barely noticeable.

Cut it Off. If all else fails, you can always leave the board a few extra inches long when you plane it. Then after you've planed the board to thickness, you can simply trim off the snipe when you cut the board to its final size. 

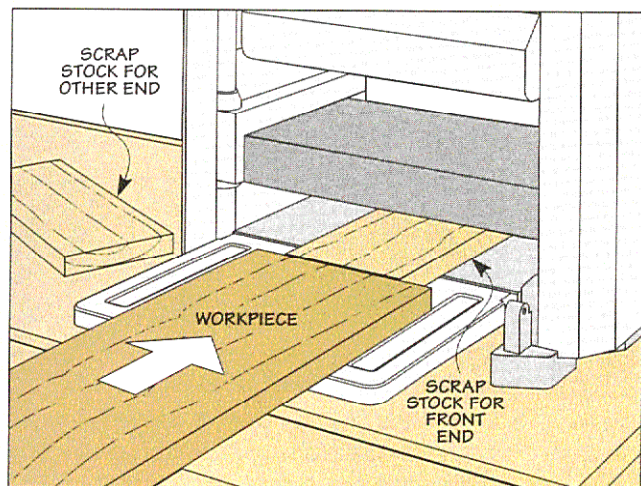

Sources

TOOL CART

There isn't really all that much hardware required to build the Tool Cart and Tool Chest starting on page 18. You can probably find all the items at a local home center or hardware store. We found a variety of tool mats at a local *Sears*.

The only items you might have trouble finding are the heavy-duty locking swivel casters and the 16" full-extension metal drawer slides. Both are available from *Rockler*.

STRAIGHT BITS

The types of straight bits featured in the Router Workshop article on page 8 are available from the *Woodsmith Store* (see margin). The 1/4" (04-108) and 1/2" (12-118) bits are made by *Freud* and the 1/2" plunge bit (45420) and the 3/4" straight bit (45220) are made by *Amana*.

STORAGE SOLUTIONS

Keeping a garage, shop, or store-room organized couldn't be easier with the *Stud Buddy* shelving described on page 46. The 5", 6 1/2", and 11"-deep shelves are available for stud walls built on 16" or 24" centers. And you can buy them individually or in conveniently packaged sets (see margin for sources).

This metal shelving will solve most storage needs, but it can be a

challenge to keep smaller items organized. So you might want to consider adding some plastic storage bins. The small and medium bins (*Akro-Mils* 30-210, 30-220) we used fit the 5" and 6 1/2" shelves, respectively, and they're available from a number of sources.

MUST-HAVE FASTENERS

The fasteners we profiled in the Materials & Hardware article on page 10 are ones we try to keep on hand in our shop all the time.

You may be able to find some of them locally, but if you have trouble locating a few, give the *Woodsmith Store* a call (see margin for contact information). They carry all the fasteners featured as well as the trim washers. *McFeely's* carries *Confirmat* and sheet metal screws plus trim washers.

LEIGH D4 DOVETAIL JIG

A number of the sources listed in the margin carry the *Leigh D4* dovetail jig looked at in the Jigs & Fixtures article on page 12. As mentioned, the jig will run about \$400, but it includes everything you'll need to get started working.

Optional accessories can be purchased to allow you to cut through mortise and tenon joints, box joints, and even custom-shaped joints like

"bears ears" and "waves" that use *Isoloc™* templates. And depending on the thickness of materials you plan to work with, there are a number of different straight and dovetail bit combinations available.

T-MOLDING

As the article on page 28 showed, sheet goods can be covered with some pretty interesting edging called T-molding.

There are a number of mail-order sources listed in the margin that carry T-molding. You'll find T-molding available in different sizes and colors to suit your specific needs. The 1/16" or 5/64" slot cutters required to install the T-molding are available from the same suppliers as well.

BRASS-BODY HAND PLANE

The *Hock* plane iron (BP175) and chipbreaker (#3) we used are available from the *Woodsmith Store* and *Hock Tools*, both listed at right. The knob (KHJ-120) came from *Reid Tools*, and *McMaster-Carr* has the 3/16"-thick brass stock (8954K179).

To cut the brass, we used a non-ferrous blade (*Freud* LU89M008) we ordered from *Woodworker's Supply*. They also carry the 3/16", 10-TPI band saw blade we used to shape the brass sides. 

MAIL ORDER SOURCES

Similar project supplies may be ordered from the following companies:

- Woodsmith Store**
800-835-5084
www.woodsmithstore.com
Casters, Drawer Slides, Fasteners, Hock Blades, Leigh D4 Jig & Accessories, Knobs, Amana & Freud Straight Bits & Slot Cutter Bits, Stud Buddy Shelving, Plastic Storage Bins, T-Nuts
- Rockler**
800-279-4441
www.rockler.com
Casters, Drawer Slides, Slot Cutter Bits, T-Molding
- Reid Tool**
800-253-0421
www.reidtool.com
Cap Screws, Casters, Knobs
- Leigh Industries Ltd.**
800-663-8932
www.leighjigs.com
Leigh D4 Jig & Accessories
- McFeely's**
800-443-7937
www.mcfeelys.com
Fasteners, Trim Washers
- Stud Buddy**
888-578-7452
www.studbuddy.com
Shelving, Plastic Storage Bins
- T-Molding.com**
866-422-5815
www.t-molding.com
Slot Cutter Bits, T-Molding
- JNK Products**
877-873-3736
www.jnkproducts.com
Garage Flooring
- Griot's Garage**
800-345-5789
www.griotsgarage.com
Garage Flooring
- Gladiator GarageWorks**
866-342-4089
www.gladiatorgv.com
Garage Flooring
- Hock Tools**
888-282-5233
www.hocktools.com
Chipbreakers, Plane Irons
- Woodworker's Supply**
800-645-9292
www.woodworker.com
Band Saw Blades, Table Saw Blades
- McMaster-Carr**
630-833-0300
www.mcmaster.com
Brass Stock, Casters, Knobs, Plastic Storage Bins

SHOPNOTES PROJECT SUPPLIES

We now feature hardware from **ROCKLER** in many of our new project kits. To order, please use our toll-free order line below. It's open Monday through Friday, from 8 AM to 5 PM Central Time. Before calling, please have your VISA, MasterCard, Discover, or American Express card ready.

If you would prefer to mail in an order, please call the toll-free phone number below for more information concerning shipping charges as well as any applicable sales tax.

1-800-347-5105

ShopNotes[®] on the web

- "Online Extras" - Plans, Patterns, & More
- Over 100 Woodworking Tips Online
- Visit Our Woodworking Shop Tours Gallery
- Project Plans You Can Download
- Catalog of Project Kits, Tools, Jigs, & Plans
- Forums for Woodworking, Tools, & Classifieds
- Links to Other Woodworking Sites

www.ShopNotes.com

Scenes from the Shop

Fine Tool. There's nothing quite like the feel of using a hand plane to make a whisker-thin shaving. And now you can do it with a brass-body hand plane you make in your own shop. Plus, you'll learn how to solder the brass (upper right photo) and then finish the body to make the joints virtually disappear (lower right photo). Detailed plans and instructions begin on page 32.

