

**NEW** HIGH  
TECH  
Hand Tools

**SPECIAL SHOP STORAGE ISSUE!**

[www.ShopNotes.com](http://www.ShopNotes.com)

# ShopNotes

Vol. 14 Issue 80

*DREAM SHOP PROJECT*

## Heirloom Tool Cabinet

*MASTER THE TABLE SAW:*

## 7 Sure-Fire Solutions for Perfect Dadoes

*BEST-BUILT JIGS:*

## Turn Your Router into a Jointer

**PLUS:**

- **SETTING UP SHOP  
Lumber Storage**
- **ULTIMATE GARAGE  
Slat-Wall Systems**



# Contents

## Features

**dream shop project**

### Heirloom Tool Cabinet

**GO ONLINE EXTRAS**

16

*With solid frame and panel construction, this heirloom tool cabinet will be a welcome addition to any workshop.*

**technique**

### Fitting Inset Doors

26

*Fitting inset doors can be a challenge. But with these handy tips and tricks, sure-fire success is only a few steps away.*

**weekend workshop**

### Knock-Down Wall Shelf

28

*This knock-down wall shelf is an easy-to-build project for the shop. Or you can use it in the house to display just about anything.*

**best-built jigs & fixtures**

### Router Jointer

32

*Turn your router into a precision jointer that will give you an edge that's smooth, straight, and perfectly square.*

## Departments

### Readers' Tips

4

**router workshop**

### Multi-Profile Bits

8

**NEW!**

*With only a single bit, you can create dozens of profiles just by adjusting the router bit and fence.*

**materials & hardware**

### Working with Epoxy

10

**NEW!**

*Here's what you need to know about working with a versatile adhesive — two-part epoxy.*

**jigs & accessories**

### Dowelmax

12

**NEW!**

*Doweling joints don't get much easier or more accurate than with the Dowelmax system.*

### Shop Short Cuts

14

**NEW!**

*Shop-tested tips and techniques to solve your woodworking problems.*

**hands-on technique**

### Wedged Mortise & Tenon

30

**NEW!**

*Create a perfect-fitting mortise and tenon on the table saw — and then secure it with a wedge.*



Knock-Down Wall Shelf page 28



Fitting Inset Doors page 26

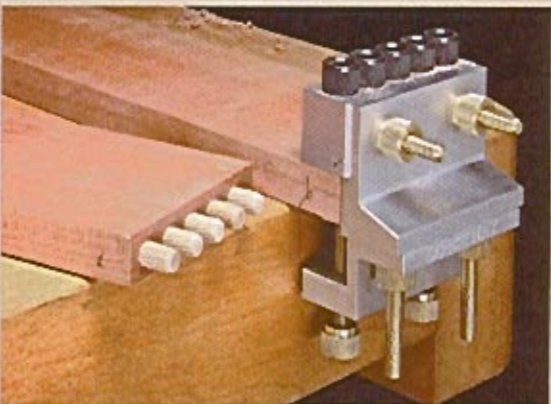

Dowelmax page 12



Heirloom Tool Cabinet

page 16

# Cutoffs

**S**torage. Sooner or later, it's a problem almost every woodworker has to face. But fortunately, there are a number of different approaches to the problem. In this issue we've put together a collection of projects and articles to help you address your shop storage needs.

The heirloom tool cabinet on page 16 and the knock-down wall shelf on page 28 both take a traditional approach to tool storage. But for a more modern solution, be sure to check out the article on slat-wall storage systems that begins on page 48.

And finally, on page 42, we've put together some practical ideas for lumber storage.

**New Face.** In the last issue of *ShopNotes*, I told you about some of the changes we made to the magazine. More pages and new departments. In my excitement, I forgot to mention one thing — we've added a new face as well. Mitch Holmes has joined us as an assistant editor.

**Help Wanted.** While I'm on the subject of new faces, we're looking for a project designer to join our team. If you have an in-depth understanding of project design, woodworking and home-improvement skills, and the ability to turn ideas into computer-generated drawings, we'd like to hear from you. Send a resume detailing your experience to: HR, August Home Publishing, 2200 Grand Ave., Des Moines, IA 50312. Or check out our website at [www.AugustHome.com](http://www.AugustHome.com) for more information.

*Terry*

**in the shop**  
**High-Tech Rasps** \_\_\_\_\_ **38**

**NEW!** *Rasps have been around for years. But there's a new breed of rasps every shop should have.*

**setting up shop**  
**Lumber Storage** \_\_\_\_\_ **42**

**NEW!** *Storing lumber doesn't have to be frustrating. We'll show you how to get it under control.*

**mastering the table saw**  
**7 Solutions for Perfect Dadoes** \_\_\_\_\_ **44**

**NEW!** *In search of tearout-free dadoes? These seven proven techniques ensure the best results.*

**GO ONLINE EXTRAS**

**great gear**  
**Preventing Rust** \_\_\_\_\_ **46**

**NEW!** *The best way to deal with rust is to prevent it in the first place. Here's how we do it in our shop.*

**ultimate garage**  
**Slat-Wall Systems** \_\_\_\_\_ **48**

**NEW!** *No matter how serious your storage problem is, a slat-wall system can get you organized.*

**Q&A** \_\_\_\_\_ **50**

**Sources** \_\_\_\_\_ **51**



This symbol lets you know there's more information available online at [www.ShopNotes.com](http://www.ShopNotes.com)

from our Readers

# Tips for Your Shop

## Quick-Change Drafting Board

I really like the Fold-Away Tool Stand featured in Issue No. 77. But I also like to use the drafting board top for designing projects. So in order to make quick changes from the tool stand to the drafting board setup, I modified the project.

A couple of dowels and threaded inserts made the solution easy. They allow a quick change and hold the drafting board firmly in position.

To make the modification, I simply drilled four  $\frac{3}{8}$ "-dia. holes in the tool stand. Two dowels are glued in at the back of the drafting board. Then a pair of threaded

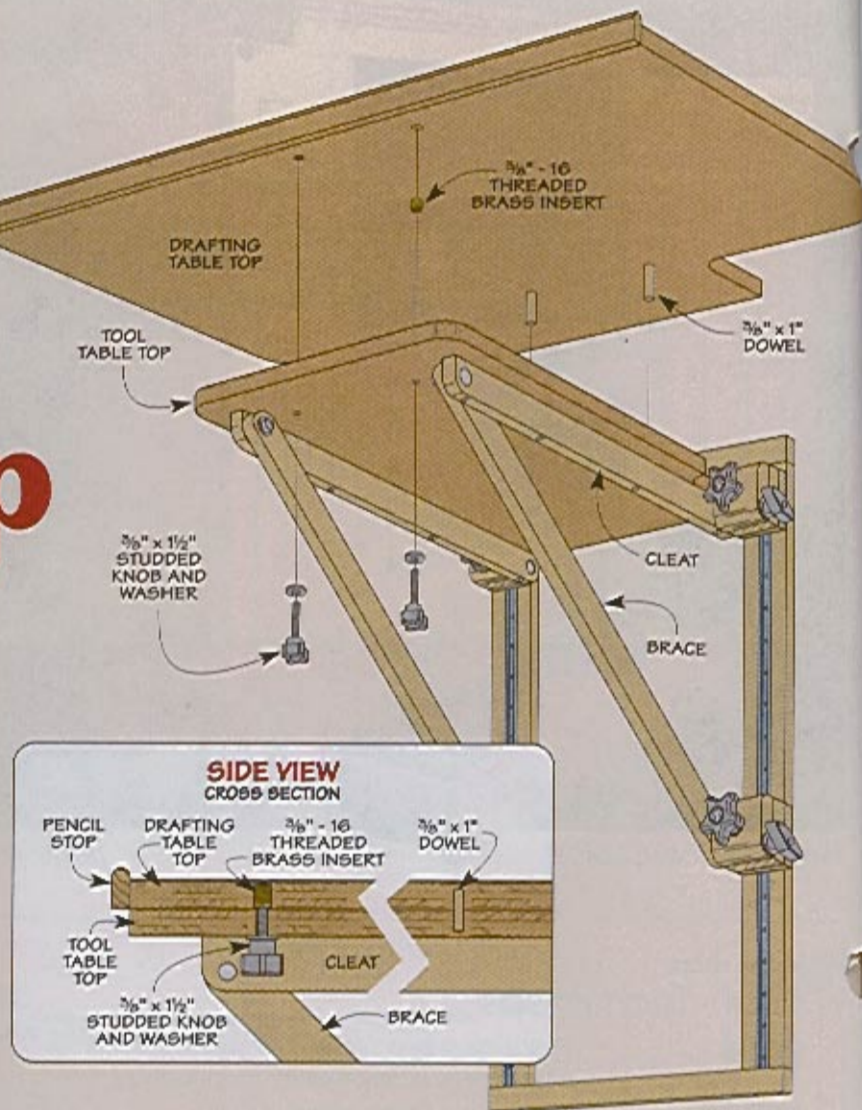

inserts are located at the front. Take extra care to make sure that the holes in the tool stand match up like you see in the drawing above.

Now changing the top is easy. And it can be done in no time at all.

*Mitch Vaccarino  
Vienna, Virginia*

### Free Tips ON THE WEB

Get more wood-working tips **free**.

Visit us on the Web at [ShopNotes.com](http://ShopNotes.com)

Sign up to receive a free shop tip by email every week.



## Heavy-Duty Push Block

I find many push sticks somewhat unnerving to use. So I made a sturdy push block for my table saw that keeps my hand well above the blade. And the wide base of the block pushes stock on both sides of the saw blade.

I first cut two pieces of scrap and then glued them together. Once the glue had dried, I screwed a  $\frac{1}{4}$ " hardboard heel to the back end. Be sure to leave the bottom end of the hardboard extending  $\frac{1}{4}$ " below the bottom of the block. This forms an end stop to capture the stock you're cutting, like you see in the photo at left.

I then added a steel utility handle. The handle is the only thing you'll save when you need to replace the block. Just make a new block and use the handle again.

*Shane O'Neill  
Asheville, North Carolina*

## Pipe Clamp Glue-up Rack

My shop has no room for an auxiliary table for glue-ups. And I don't like the mess and distraction of having to do these glue-ups on my workbench. So to solve this problem I use a wall system that holds my pipe clamps whenever I need to do assembly and gluing tasks. This makes for efficient use of my space.

My glue-up rack is nothing more than a series of cleats with holes bored to accept the ends of the clamps. To make it, I first screwed 2x4's alongside the wall studs in my shop. Since I

needed to drill a number of holes for the pipe clamps, I wanted to be sure to maintain the structural integrity of the original framing in my shop.

I set the holes 10" apart and made sure they lined up level on the other side, like you see in the photo below. This way I can do a number of glue-ups at one time if I need to.

Once the glue-up is done, it's easy to remove the pipe clamps from the wall.

*Arthur Holcomb  
Springfield, Missouri*



## Win A Porter-Cable Router

That's right, send us your shop tips. If your tip or technique is selected as the featured reader's tip, you'll win a Porter-Cable router just like the one shown below. Just write down your tip and mail it to: *ShopNotes*, Tips for Your Shop, 2200 Grand Avenue, Des Moines, Iowa 50312. Please include your name, address, and daytime phone number (in case we have any questions). If you would like, FAX it to us at 515-282-6741 or send us an email message at: [shopnotes@shopnotes.com](mailto:shopnotes@shopnotes.com). We will pay up to \$200 if we publish your tip.

### The Winner!

Congratulations to Len Urban of Rancho Mirage, California. His tip on making a shop-made setup gauge was selected as winner of the Porter-Cable router just like the one shown at the right. His setup gauge makes it easy to measure material lengths or set tool cutting depths.

To find out how you could win a Porter-Cable router just check out the information above. Your tip might just be a winner.



PUBLISHER Donald B. Peschke

EDITOR Terry J. Strohman

SENIOR EDITORS Bryan Nelson, Vincent Ancona

ASSOCIATE EDITORS Phil Huber, Ted Raife

ASSISTANT EDITORS Ron Johnson, Mitch Holmes

EXECUTIVE ART DIRECTOR Todd Lambirth

ART DIRECTOR Cary Christensen

SENIOR GRAPHIC DESIGNER Jamie Downing

SENIOR ILLUSTRATOR Roger Reiland

ILLUSTRATORS David Kallemyn, Peter J. Larson

CREATIVE DIRECTOR Ted Kralicek

SENIOR PROJECT DESIGNERS Ken Munkel, Kent Welsh,  
Chris Fitch

SHOP CRAFTSMEN Steve Curtis, Steve Johnson

SR. PHOTOGRAPHERS Crayola England, Dennis Kennedy

ASSOCIATE STYLE DIRECTOR Rebecca Cunningham

ELECTRONIC IMAGE SPECIALIST Allan Ruhnke

**CORPORATE SERVICES:** Corp. Vice President: Douglas L. Elcia, Mary K. Scherer • Controller: Craig Billie • Dir. Financial Analysis: Linda Smith • Sr. Asst.: Laura J. Thomas • Asst.: Payable: Mary J. Schultz • Asst. Receivable: Margo Petrus • Prod. Dir.: George Christler • 27 Manager: Brian VanHeuseren • Electronic Prod. Dir.: Douglas M. Lohrer • Sys. Admin.: Orla Schwabach • P.C. Maint.: Bob, Robert D. Cook • New Media Mgr.: Gordon C. Gage • Multimedia Art. Dir.: Eugene Pedersen • Web Server Admin.: Carol Schaeffer • Web Content Mgr.: David Briggs • Multimedia Designer: Ken Patton, Justin Grant • Web Prod.: Terry Walker • Research Coord.: Nicholas A. Jaeger • Prof. Dev. Dir.: Michel Sigel • Benefits Spec.: Jennifer Hietanen • Hiring Spec.: Janice Toner • Facilities Mgr.: Kurt Johnson • Office Mgr.: Joanne Johnson • Admin. Asst.: Brent Hammond • Mail Room Clerk: Lou Webster • Facilities Mgr.: Kurt Johnson **CIRCULATION:** Circ. Oper. Dir.: Sandy Baum • Circ. Marketing Dir.: Wayne J. Klingbeil • Strategic Business Analyst: Keri Schlemmer • Circ. Marketing Analyst: Patrick Walsh • Revenue Mgr.: Paul Rogers • Circ. Marketing Assoc.: Christina Barnes • Circ. Mgr.: Stephanie Fortzack • Circ. Production Mgr.: Suzanne Hajkal • Sr. Graphic Designer: Robin Friend, Randy Stabek **PRODUCTS GROUP:** Oper. Dir.: Bob Baker • Customer Service Mgr.: Jennie Brown • Warehouse Supervisor: Nancy Johnson • Buyer: Linda Jutan • Asst. Buyer: Nancy Downey • Sr. Cust. Serv. Reps.: Anna Cox, April Rowell, Deborah Rich, Valerie Jo Riley, Tammy Trachtenberg • Cust. Serv. Reps.: Kim Hurlan, Katie Parker, Tara Bonhoff • Warehouse Staff: Byrle Carey, Kim Prussif, Stephen Griffin

*ShopNotes*® (ISSN 1062-9696) is published bimonthly (Jan., March, May, July, Sept., Nov.) by August Home Publishing, 2200 Grand, Des Moines, IA 50312. *ShopNotes*® is a registered trademark of August Home Publishing. ©Copyright 2005 by August Home Publishing. All rights reserved. Subscriptions: Single copy: \$4.95. One year subscription (6 issues), \$27.95. Canada/International add \$10 per year, U.S. funds. Canadian Subscriptions: Canada Post Agreement Number 40038201. Send change of address information and blocks of undeliverable copies to PO Box 881, Station Main, Maricamp, ON L3P 8M6. Canada BN 84597 5478 RT. Periodicals Postage Paid at Des Moines, IA and at additional mailing offices. Postmaster: Send change of address to *ShopNotes*, P.O. Box 37108, Boone, IA 50037-2108.

Online Customer Service. [www.ShopNotes.com](http://www.ShopNotes.com)

- Access your account
- Check a subscription payment
- Tell us if you've missed an issue
- Change your mailing or email address
- Renew your subscription
- Pay your bill

Email: [shopnotes@shopnotes.com](mailto:shopnotes@shopnotes.com)

Write to *ShopNotes*, P.O. Box 842, Des Moines, IA 50304 or call 1-800-333-5075, 8:00 am to 5:00 pm, Central Time, weekdays. Or send an email to: [orders@shopnotes.com](mailto:orders@shopnotes.com)

## Note Caddy

I like to keep some paper close at hand for writing quick notes, hardware needs, and other pieces of information around the shop. The problem is being able to always find the paper and pencil. So I built a small caddy to help me record and keep track of these notes when I'm working in the shop.

It uses a roll of adding machine paper and contains a paper cutter and pencil holder for convenience.

The roll of adding machine paper spins on a piece of dowel cut to fit a slot in the plywood body. You'll want to size this according to the width of the paper roll you use.

I made the note caddy out of scrap  $\frac{1}{2}$ " plywood. First I cut the parts to size (see the drawing at right). Then I took a piece of  $\frac{3}{4}$ " plywood and made three dados to form the pencil holder on one side.

A bevel cut horizontally across the back piece allows you to hang the note caddy on a cleat mounted to the wall (see inset photo at left). It can also be quickly removed from the cleat when needed.

I added a piece of hardboard to the front for a smooth writing surface. A piece of hacksaw blade makes a handy way to cut the paper. A length of wire on the top holds the paper down and keeps it always ready for use.

Aaron Butler  
Danville, Pennsylvania



▲ **Mounting Strip.** A 45° angled cut across the wall cleat lets you mount this note caddy to the wall. Just "hook" the top cleat over the wall cleat like a "floating shelf."

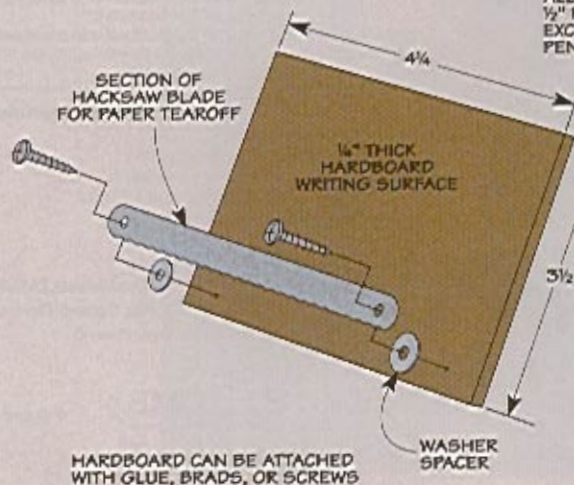
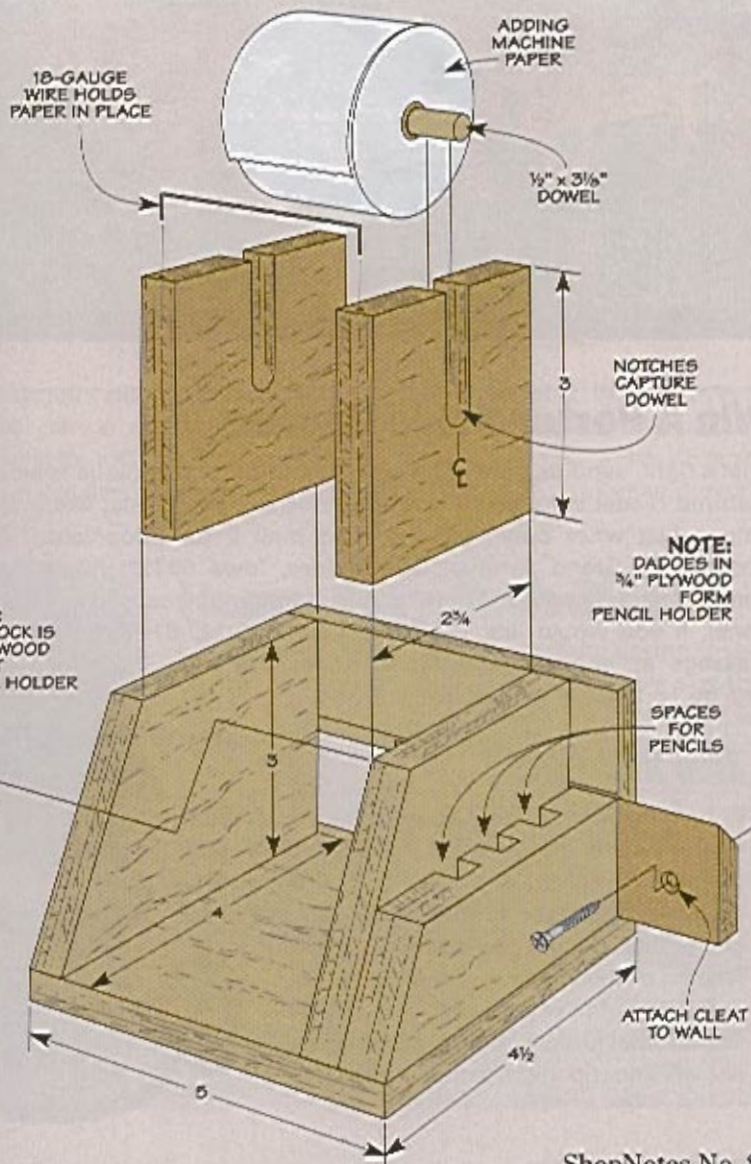

## Shop-Made Set-Up Gauge

Locating the depth of drill bit collars, determining the length of dowels, or setting the cutting depth for tools accurately can be challenging. To make this task easier, I built the set-up gauge shown in the photo at right.

The gauge frame is simply made of a piece of 1" x 1" aluminum angle. To this I added a second piece of shorter aluminum angle with a wood stop block attached, like you see illustrated in the drawing below.

A threaded insert on the top of the wood block accepts a knurled knob that is used to set the tool. Adding a penny in the bottom fills in the space so the knob can be tightened firmly and accurately. Finally, stick a length of rule to the inside and you're set to go.

Len Urban

Rancho Mirage, California

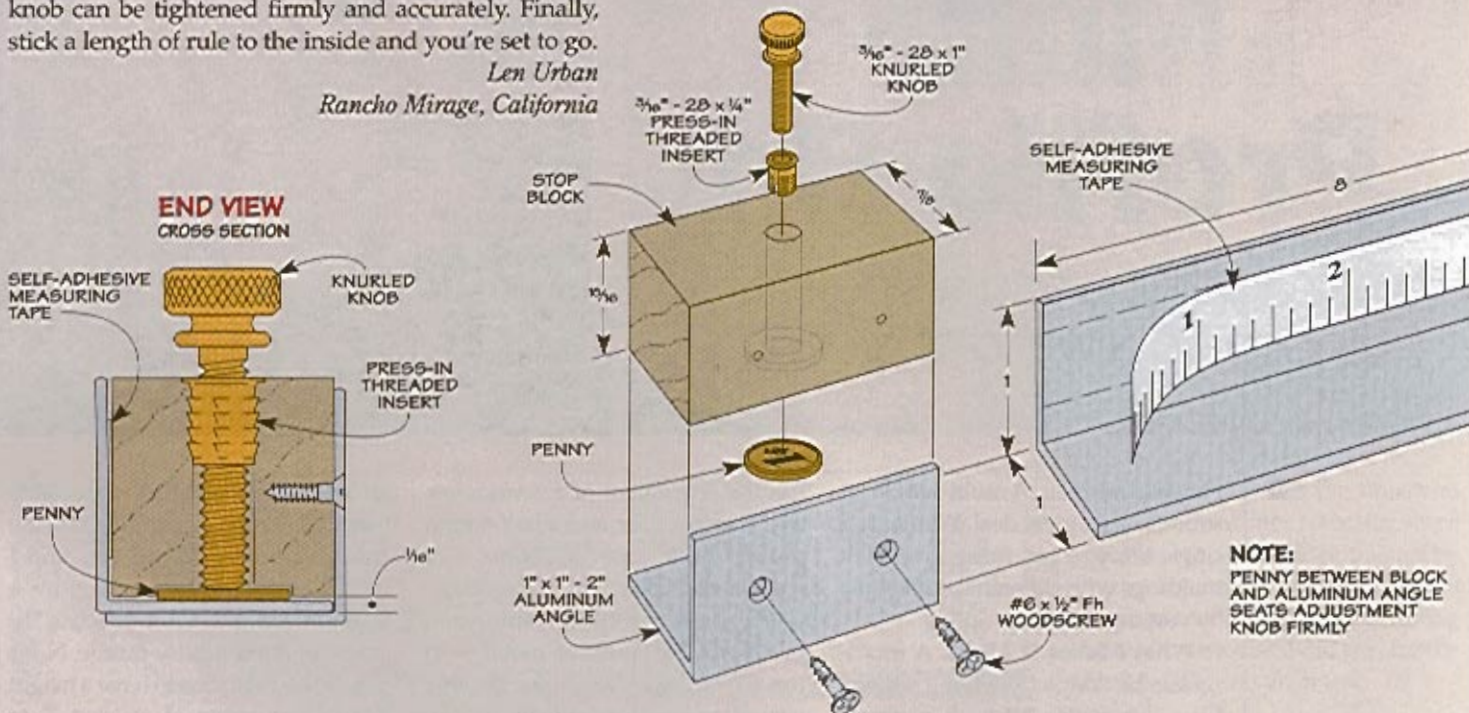

## Quick Tips



▲ **Stan Gutowski** of Oakham, MA, uses Glad's new Press & Seal wrap to temporarily seal finish or stain containers. It's easy to use. Just tear off a piece, lay it over the top of the container, and press it in place to seal the top. Then lift it off when you need to use it again.



▲ **William Kassay** of Hackettstown, NJ, keeps a roll of 2" tape close by when routing. The roll supports his powered-off router upright while preparing the next cut.

getting the  
most from a

# Multi-Profile Bit

Imagination and a single bit  
open up a world of profiles.



■ I have to admit it. A multi-profile bit sounds like a great deal. With only a single bit, you can make dozens of moldings with different profiles just by varying the setup.

**What Makes It Multi.** A multi-profile bit is exactly what it sounds like — a router bit with multiple profiles on it. The bit shown below

has the equivalent of a roundover, two cove profiles, and a half-round profile built into it. Note: For sources and cost, turn to page 51.

All these profiles result in a pretty sizable hunk of metal — it tips the scales at three-quarters of a pound and is just shy of 2¼" in diameter. So there a few things you'll need to keep in mind when using one of these bits.

**Getting Ready.** For starters, a variable-speed router is a must. It's just not a good idea to run a bit this size any faster than 16,000 RPM. Plus, anything less than a couple horsepower will just make the router work too hard.

But probably the most important thing to do is install this bit in a router that's mounted in a table. It's much safer and you'll be able to make full use of all the different profiles.

Another thing to check is whether the bit fits the opening in both your router insert and the fence. I had to mount my router to

an insert plate that had replaceable inserts in order to provide a wide enough opening for the bit. And I had to make a taller fence with a larger opening to accommodate the height of the complete profile. Note: Your router also has to have a height adjustment range of at least 2" to provide access to the entire profile.

**Using the Bit.** Once you have the bit locked securely in place, you're ready to give it a spin and create a few of the profiles shown on the opposite page. The drawings show how to set the bit height and fence for each profile. And the Shop Tip box will give you a couple ideas on how to get the best results.

By using various parts of the profile along with different fence settings, you can create a wide range of profiles. The box on the opposite page shows how to use a scrap of the profile as a template for designing your own profiles.

A multi-profile bit won't solve all your routing needs. But for complex profiles with minimum hassle, it's a good bit to have on hand. 🛠️

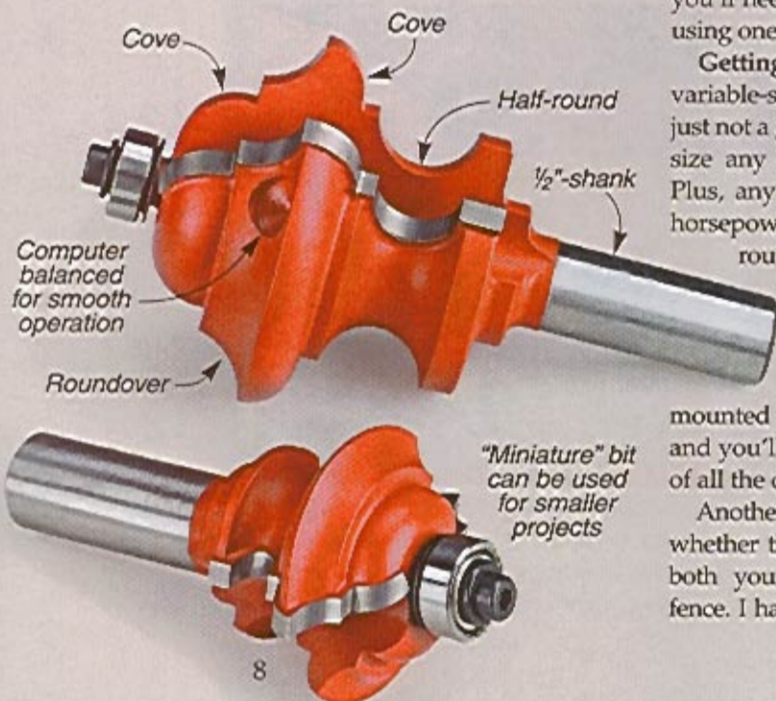

"Miniature" bit  
can be used  
for smaller  
projects



## Simple Profiles

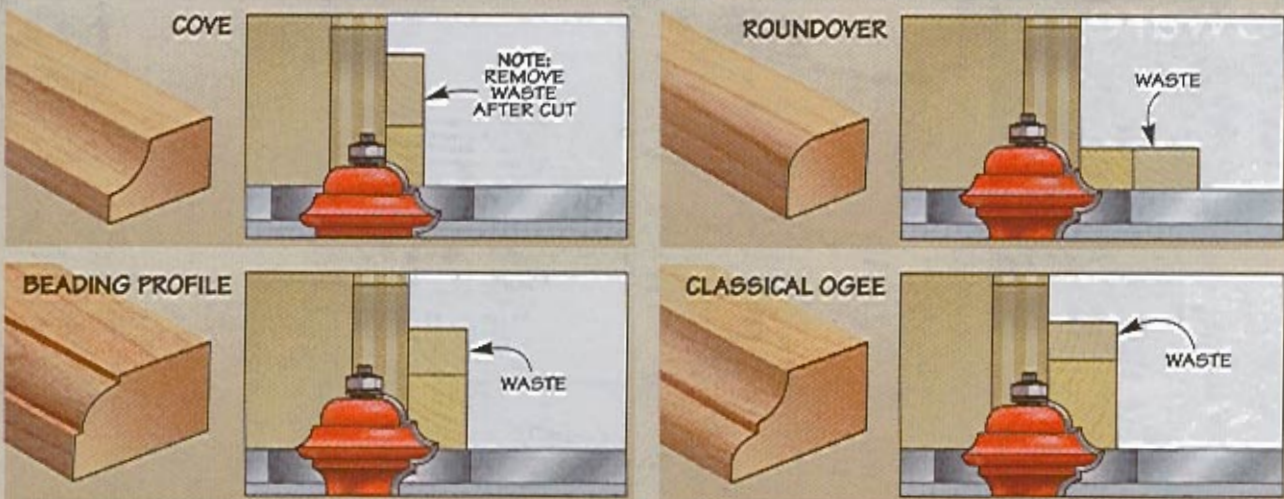

## Complex Moldings

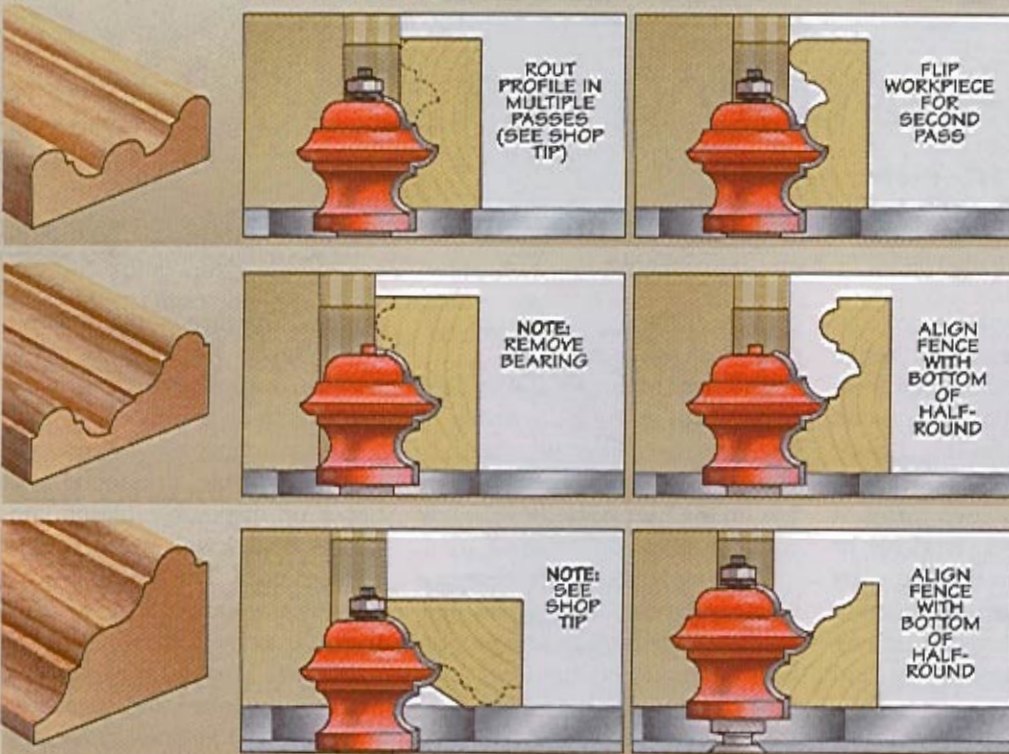

The drawings you see here show the fence in its final position. But to get the best results, you'll want to cut the profile by making several shallow passes instead of one deep cut.

And to minimize the time you spend at the router table, for some profiles it's a good idea to start by removing any excess material with the table saw. The drawing below shows how I did this for the final profile shown at left.

**SHOP TIP**

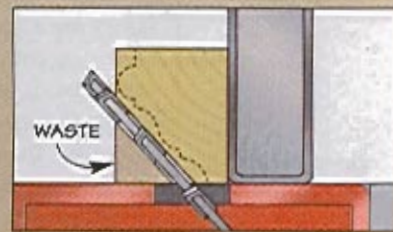

## More Profiles: Design Your Own

Coming up with your own profiles using a bit like this can be a challenge. To help drive the creative juices, I made a template out of a cutoff from a piece of scrap I routed to the full depth and height of the profile, as in the photo at right.

Using the template as a guide, you can make just about any profile you can draw. Just keep in mind where the "waste" areas are, the location of the bearing, and most importantly, the need for adequate stock support.



NEW Department!

# MATERIALS & Hardware



## working with Epoxy

Two-part epoxy is a valuable asset in the shop — once you know how to work with it.

For most woodworking projects, plain old wood glue is my adhesive of choice. But I've discovered there are times when yellow glue won't cut it. When that's the case, I reach for two-part epoxy.

**What is it?** The two parts of epoxy are a resin and a hardener, or curing agent. When the two parts are mixed, a chemical reaction occurs to form an incredibly strong adhesive that is waterproof and doesn't shrink.

**Adjustable.** One thing I like about epoxy is that its curing time and consistency can be modified to suit the task at hand. For example, when I'm assembling a project with a lot of parts, switching to a hardener with a longer setting time will give me some extra time to get all the pieces in place.

You can also modify the consistency of the epoxy. Changing the thickness comes in handy if you're working on a vertical surface. Here a thicker epoxy won't drip and run out of a hole. The box on the

bottom of the opposite page will give you a few more details.

**Different Materials.** But the best thing about epoxy is its ability to glue together different materials, like metal to wood. (The Shop Tips box on the next page shows a few common shop applications.)

Working with epoxy can seem a bit intimidating. Unlike wood glue, you have to mix up precise proportions of resin and hardener each time you use it. It's the mixing stage that can trip you up and result in a poor-quality joint. But with the right techniques, you'll find yourself using epoxy more often.

### USING EPOXY

The first step in preparing epoxy is getting the proportions just right. The typical ratio is one part resin to one part hardener. But the ratio may vary from one manufacturer to the next. So it's a good idea to carefully read the directions.

Once the two parts are mixed, the curing process can't be

stopped. This means you can't save any leftovers for later. So try to measure out only enough resin and hardener to do the job.

To make mixing and cleanup as easy as possible, I've found wax paper or disposable plastic containers to work well. Just steer clear of foam cups. The curing process generates enough heat to melt them. (Trust me, I know.)

**Mixing.** Mixing up epoxy isn't like stirring cream and sugar into your coffee. If an epoxy joint fails, you can usually trace it back to one thing — mixing.

A square-tipped spatula makes it easier to get all the resin and hardener mixed together. To see how it's done, take a look at the four steps on the next page.

**Safety Tip:** Any time you're using epoxy, it's a good idea to work in a well-ventilated area and wear gloves and eye protection.

**Applying.** With the epoxy mixed, you're ready to apply it. Just make sure the joint is clean and

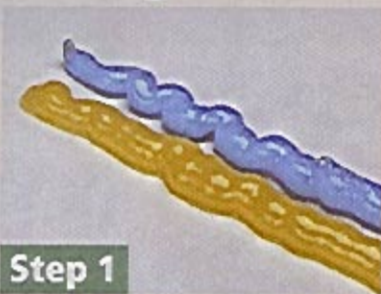
**Step 1**

**Proper Ratio.** Measure out the recommended amounts of the resin and hardener side by side.

**Step 2**

**Mix Thoroughly.** Use a square-tipped spatula and combine the two parts with a swirling motion.

**Step 3**

**Mix It Again.** Continue mixing the two parts by smoothing out the mixture and folding back on itself.

**Step 4**

**Consistent Color.** You'll know the epoxy is thoroughly mixed when the color is uniform.

dry and apply epoxy to both surfaces with a disposable glue brush.

Clamping an epoxy joint is a little different than with regular yellow glue. Instead of tightly squeezing the parts together, all you need to do with epoxy is simply hold them in place.

I like to use rubber bands and tape to get just the right amount of pressure. There's one other thing to note about assembly. You don't want a lot of squeezeout either. That will lead to a starved joint.

**Cleanup.** Once epoxy dries, it's almost impossible to remove. So I make sure to clean up any squeezeout with a rag and some denatured alcohol. And just like an oily rag, be sure to let any unused epoxy cure before you toss it out. This way, any heat generated during the curing process won't result in a fire.

One final thing: If some epoxy gets on your skin, use a waterless hand cleaner to remove it. Denatured alcohol will just drive the epoxy into your skin. ⚠

## Thicken with Adhesive Fillers

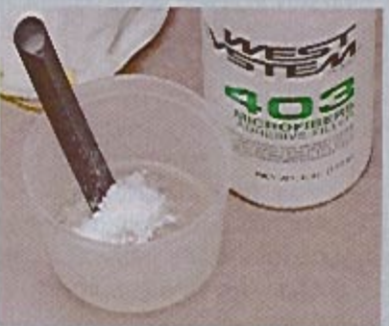

Adding fillers to epoxy adjusts its consistency without sacrificing strength. There are a variety of fillers available that are suited to specific tasks and working characteristics. For woodworking, I've found you can even make your own custom filler by sanding a piece of scrap with 320-grit sandpaper and mixing it in the epoxy.

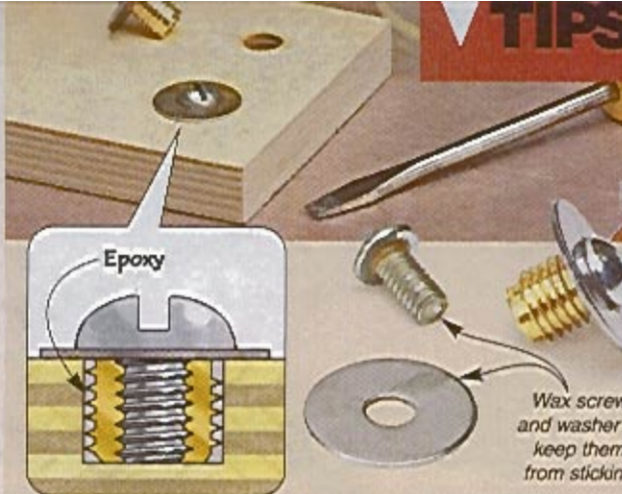

▲ **Super-Strong Threaded Inserts.** Putting epoxy in the hole for a threaded insert adds strength to the insert's grip, preventing it from stripping out.

One of my favorite uses for epoxy is "gluing" metal items, such as T-nuts and threaded inserts (top photo), in place on my projects. The epoxy adds strength to the hardware's gripping power, reducing stripout. But there is a technique to using epoxy this way.

I like to anchor the threaded inserts in an oversized hole with a little epoxy, as you can see in the photo and drawing above. When installing the threaded insert, I fit a screw with a washer in the threaded insert. The washer acts as a leveler for the epoxy. To keep the screw and washer from getting glued to the workpiece, you'll need to apply some paste wax to them. After the epoxy sets, you can remove the screw and washer.

You'll even find this technique works to fix stripped-out screw holes (middle photo).

Another handy use for epoxy is shown in the photo below. Coating the bottom of table legs prevents water from wicking into the end grain, which can lead to moisture damage and stains.



◀ **Sealing End Grain.** Coating the bottom of table legs with epoxy acts as a waterproof sealer.



**Non-Strip Screw Holes.** Epoxy is a quick way to prevent or to repair stripped screw holes.

NEW  
Department!

## JIGS & Accessories

Finally!  
A versatile  
doweling jig that's  
quick, accurate,  
and best of all,  
easy to use.

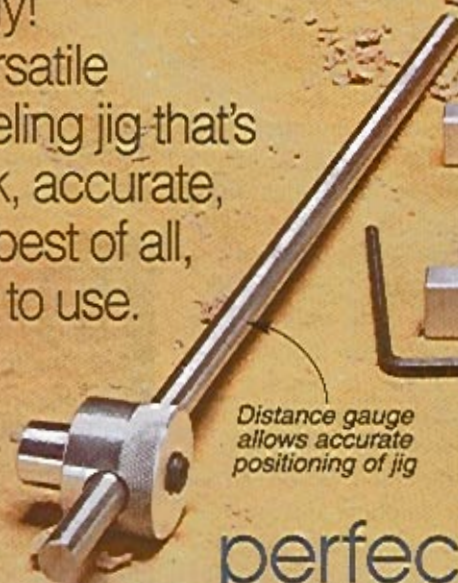

Distance gauge  
allows accurate  
positioning of jig



Jig can be  
repositioned  
quickly with  
indexing pin

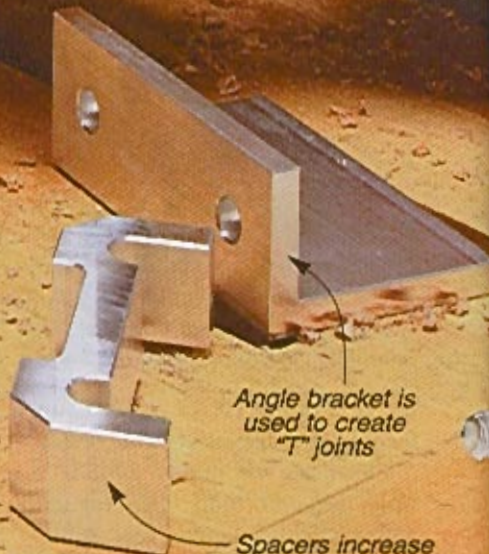

Angle bracket is  
used to create  
"T" joints

Spacers increase  
capacity and are  
used to make  
offset joints

# perfect joints with the Dowelmax

■ In the past, my experiences with dowel joinery were usually pretty frustrating. No matter how carefully I worked, producing joints that fit together accurately and easily was always a struggle. And like a lot of other woodworkers, I had pretty much given up on using dowel joinery in my projects.

That's why it was such a welcome surprise when I recently had a chance to try out the new *Dowelmax Doweling System*.

What makes the *Dowelmax* jig different? Well, it can be summed up pretty easily.

First, it's quick and easy to use. Second, the joinery it produces is

next to perfect. And, to top it off, it's versatile enough to handle just about any joinery chore you throw at it.

**The Jig.** When the box came in the mail and I opened it up, I found quite an assortment of parts and pieces. But what quickly drew my attention was the heavy, anodized aluminum jig itself. As I looked it over, my first thought was that it had a fit and finish more like an aircraft part than a woodworking jig.

**A Basic Joint.** Eager to give the jig a try, I rounded up a couple pieces of stock, got out my hand drill, and took a quick look at the instructions. Out of the box, the jig is set up to center the  $\frac{3}{8}$ "-dia. holes across the width of  $\frac{3}{4}$ " stock. So it's a natural for joining simple frames — like you'd make for the face frame of a cabinet (left photo). The basic step-by-step process is shown in the box at the bottom of the opposite page.

Cutaway of  
dowel joint

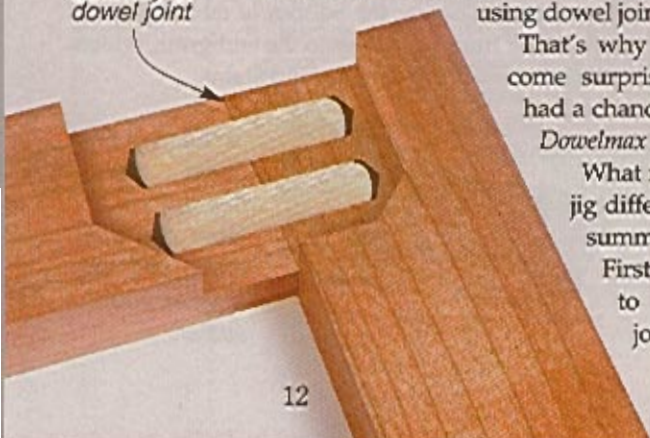

The key to the accuracy and easy use of the jig is the precise spacing of the five hardened-steel bushings. What this means is that you don't need to do any measuring. You simply reference the end of the jig to the end or edge of the workpiece to drill your holes. This saves time and eliminates the chance of measurement or setup errors.

My first attempt was completed in short order and when I assembled the joint, both the faces and the edges were dead-on flush. And once you have the fundamentals down, most other types of joints come easily. Next, I tried a miter joint, as in the photo on the opposite page, and things went just as smoothly with identical results.

**Beyond the Basics.** Simple frame joints are just the tip of the iceberg for this jig. One of the uses that I found to be a real "break-through" is shown in the photo at right. If you've ever tried to use dowels to reinforce an edge-to-edge joint, you know how difficult it is to get the holes to line up so that the joint fits together easily. The *Dowelmax* solves this problem with an adjustable distance gauge. You use it to accurately space your holes along the length of the boards to be joined. The result is that the holes match up perfectly and the joint goes together without a fight.

**And More.** Normally, you wouldn't think of using dowels to create strong "face" butt joints. But as you see in the photo at left, the *Dowelmax* jig makes it easy. The first set of holes in the end of one workpiece is drilled as usual. Then with a quick transformation of the jig, you're able to drill matching holes in the face of the second workpiece. And at this point I probably don't need to tell you how well the joint fit.

For some of the other uses of the *Dowelmax*, you need to dip into the extra



▲ **Edge Joints.** The distance gauge is used to accurately space dowel holes in edge joints.

parts that come with the jig. The spacers provided give you a couple of options. One is to use them to expand the jig to fit over wider stock (up to about 4"). Secondly, they allow you to make offset joints, such as when joining a table rail to a thicker leg.

**Worth the Cost?** At this point there's one important unanswered question. How much? Well, as you might guess, all this precision tooling comes with a cost. The *Dowelmax System* is only available directly from the manufacturer for about \$230 (see sources on page 51). But I can't think of many tools that can do as much or as well for a comparable cost. So I wouldn't have a problem finding a home for the *Dowelmax* in my shop. 🛠️

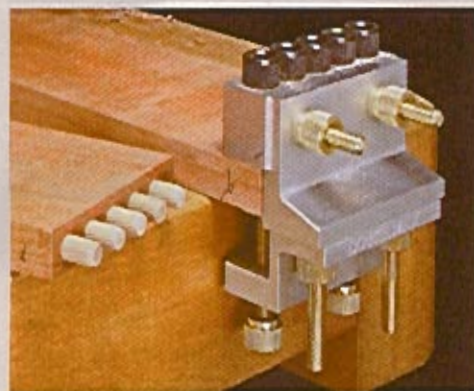

▲ **Face Joints.** All it takes is an easy reconfiguration of the jig to drill holes in the face of a board for a butt joint.

## Step-By-Step With The Dowelmax System

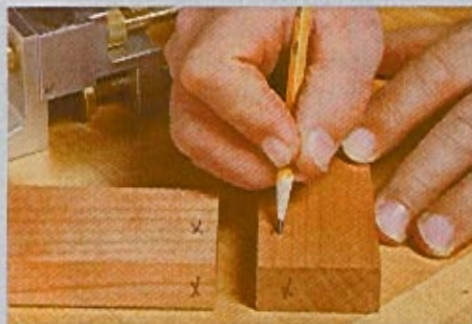

▲ **Reference Marks.** The first step is to make two sets of reference marks. Marks on the flush edges and flush faces show you how to orient the jig on the workpieces.

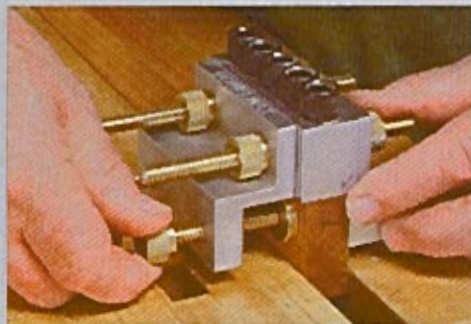

▲ **First Holes.** To drill the holes in the edge of the first workpiece, use the reference marks to position the jig with the center block flush to the end and tighten it down.

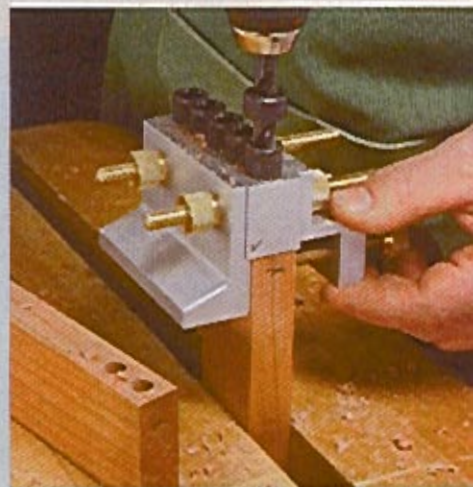

▲ **Matching Holes.** To drill matching holes in the end of the mating piece, you repeat the process. The jig is clamped flush with the marked edge of the workpiece.

# SHOP Short Cuts



## Dowel Locating Jig

■ The use of pins, such as the dowels used to align and connect the cabinet to the base of the tool chest on page 16, is a very effective technique. But if the holes for the dowels are not precisely lined up, the cabinet and the base won't fit flush with each other when the

cabinet is set on the base. To make this task easier, I built a simple jig to accurately place the holes.

**The Jig.** The jig is nothing more than a couple of pieces of plywood joined together with a dado, as shown in the drawing below. A piece of hardwood added to the

back aligns the back of the jig. Holes drilled in the jig provide a template for accurate location of the holes. It also ensures the holes will be drilled straight (see photo inset above).

**Using the Jig.** To use the jig, just clamp it on the base with the vertical piece butted against the side and the hardboard stop tight against the back. Using the holes in the jig as a guide, simply drill two holes for the dowels to equal depth, like you see in the photo above.

To drill the holes on the other end, just flip the jig over. Then repeat the entire procedure on the cabinet.

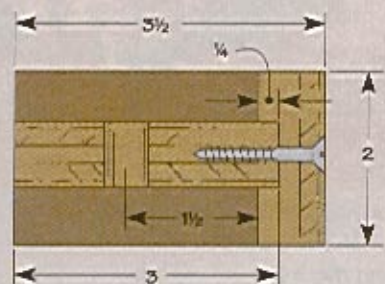
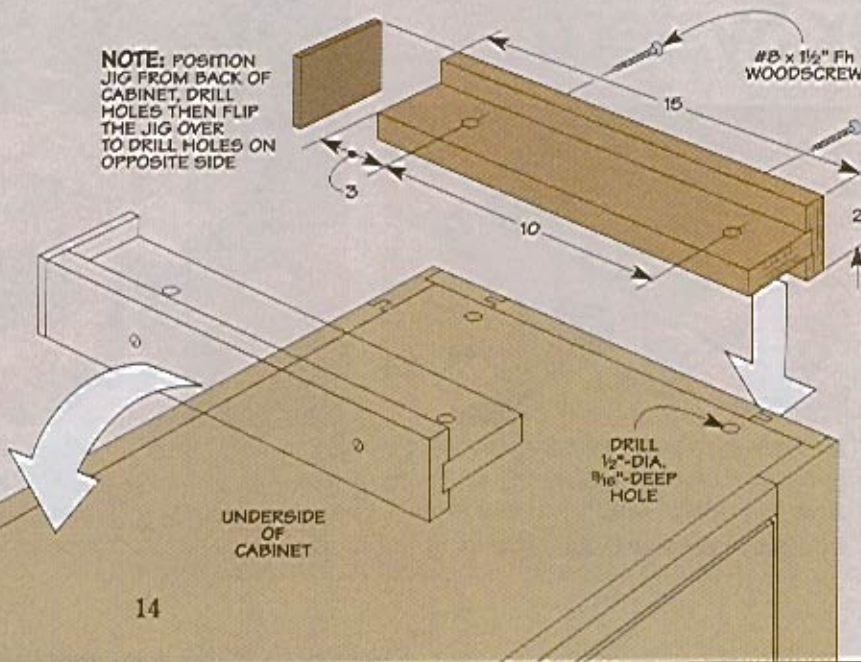

CROSS SECTION

## Taper Sled

Cutting a perfect taper is always a challenge. This is especially true when cutting large blocks like those needed for the table of the router jointer on page 32. The trick is to make sure you cut the tapered angle accurately while maintaining the dimensions of the workpiece.

I found the easiest way to do this is to make a sled with a fence and a stop that holds the blank in position as the cut is made (Figure 1). It's simple to make and will save you a lot of time and frustration.

**Sled Base.** The first thing you'll need to make is a base for the sled. I made my base from  $\frac{3}{4}$ " plywood but you can use any material that will provide a firm base of support.

Next, I cut the sled to width, as shown in the First Step of Figure 2 below. You'll want to leave the rip fence in this position.

**Position the Fence and Stop.** First, lay out the blanks on an oversized piece of stock. You'll make blanks for both the infeed/outfeed table and the table support.

Then lay the blank on the sled and align the tapered cut line along the edge of the sled base (Second Step below). Now you can draw a reference line onto the sled along the edge and end of the blank to define the position of the blank.

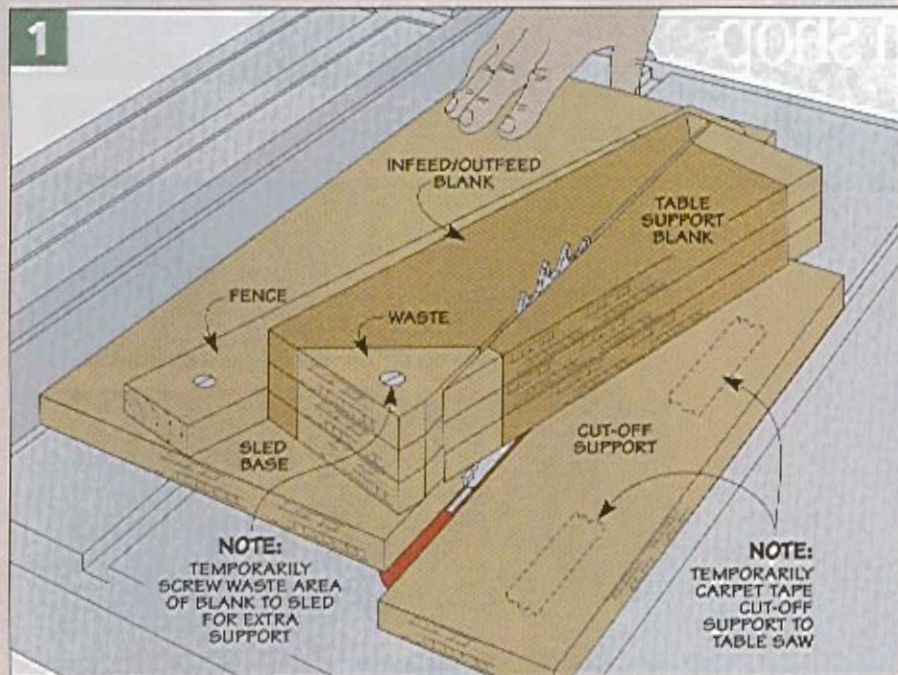

Next, attach a fence and stop so they line up with the reference lines. They should fit snugly against the top edge and end of the blank (Third Step below). Finally, secure them in place with screws.

**Make the Cut.** To cut the tapers, simply lay the block against the fence and stop (see Figure 1). To keep the workpiece from shifting, I also drove a screw through the waste area and into the sled.

Before making the cut, I placed a piece of plywood on the other side of the blade to support the piece

being cut off. Carpet tape on the bottom of this cut-off support can be used to secure it firmly to the table top. Then, it's just a matter of pushing the sled along the rip fence to cut the blank to the right size. You can then repeat the procedure to make the second blank.

**Trim the Blanks.** With the tapers cut, you can now move on to trimming the jointer table blanks to size (Figure 3). The miter gauge on your table saw makes this easy.

First, angle your miter gauge to 45°. Then push the miter gauge forward and trim the ends of the infeed/outfeed blank to the desired dimensions (Figure 3). Trimming the table support blank is just as easy. Simply reset your miter gauge so it's square with the blade. Then make a couple of quick cuts and you're done.

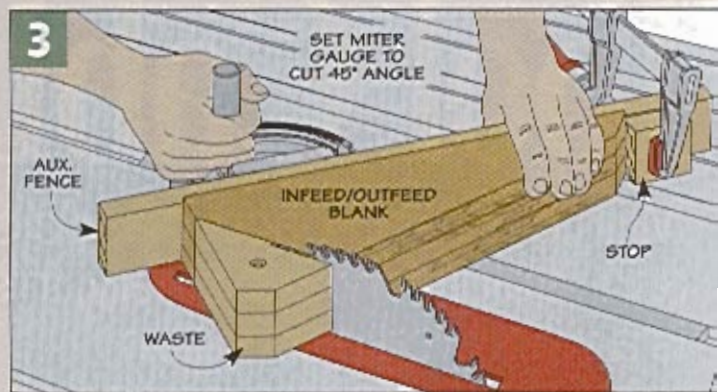
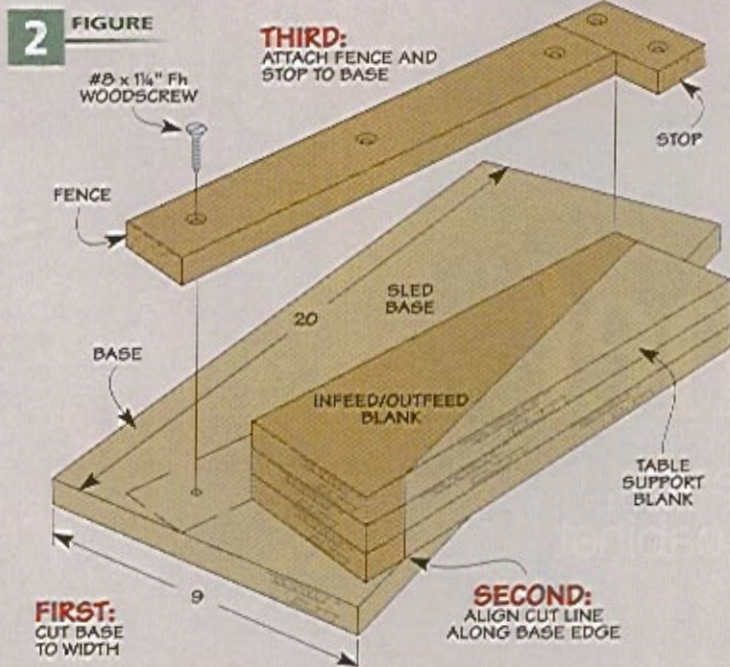

dream shop **project**



# heirloom Tool Cabinet

With plenty of space, classic design, and straightforward joinery, this cabinet is a woodworker's dream



# Exploded View Details

OVERALL DIMENSIONS:  
18¼"D x 36½"W x 72"H

**ShopNotes**

**GO ONLINE EXTRAS**

To download a free cutting diagram for the Tool Cabinet, go to:  
[www.ShopNotes.com](http://www.ShopNotes.com)

SHOP-MADE MOLDING ADDS TO TRADITIONAL LOOK

CASE AND DOORS FEATURE SOLID-WOOD FRAME AND PANEL CONSTRUCTION

TO FIT INSET DOORS TURN TO PAGE 26

TOOL CABINET IS MADE FROM STRAIGHT-GRAIN DOUGLAS FIR

DOWEL PINS KEEP CABINET FROM SLIDING OFF BASE

HEAVY-DUTY BASE PIECES ARE GLUED UP OUT OF 1½" THICK STOCK

OPTIONAL DRAWER CASE ORGANIZES SMALL HAND TOOLS

DRAWER IN BASE ADDS EVEN MORE STORAGE

DRAWER LINERS PROTECT TOOLS AND KEEP THEM FROM SHIFTING

FULL-EXTENSION DRAWER SLIDE

KNOCK-DOWN BASE USES DRAWBOLT JOINERY

ADJUSTABLE LEG LEVELERS PROVIDE FIRM FOOTING ON UNEVEN SURFACE

DRAWBOLT

SHELVES CAN BE ADDED TO THE BASE FOR MORE STORAGE SPACE

FOR DETAILS GO TO [WWW.SHOPNOTES.COM](http://WWW.SHOPNOTES.COM)

**1** FIGURE

**NOTE:**  
CASE STILES  
AND RAILS ARE  
3/4"-THICK STOCK.  
PANELS ARE  
1/2" THICK

**NOTE:**  
MAKE TWO  
SIDE PANEL  
ASSEMBLIES

**SIDE PANEL**  
(4 1/2" x 28 3/4")

**SIDE STILE**  
(2 3/4" x 37 1/4")

**SIDE  
BOTTOM RAIL**  
(6 1/2" x 11")

**SIDE  
CENTER STILE**  
(3" x 28 3/4")

**BACK  
CENTER STILE**  
(3" x 28 3/4")

**BACK STILE**  
(3" x 37 1/4")

**BACK TOP RAIL**  
(3" x 29")

**BACK BOTTOM RAIL**  
(6 1/2" x 29")

**SIDE TOP RAIL**  
(3" x 11")

**BACK PANEL**  
(13 1/2" x 28 3/4")

1/8" SHADOW LINE

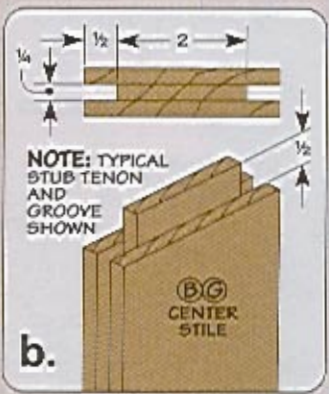
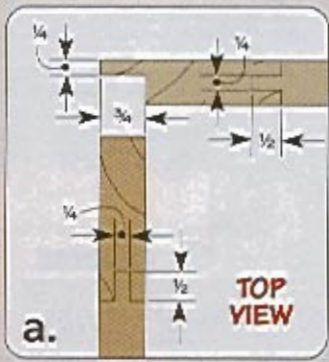

# building the Case

It's hard to put a finger on what I like best about this tool cabinet. Certainly, the first thing you notice is the striking color and grain of the Douglas fir. I could also point to the huge amount of storage provided by all the shelves and drawers. Or maybe it's the heavy-duty stand that keeps the tools within easy reach. On the other hand, perhaps the way all these features come together is what makes it such a standout project.

One thing is certain. You're sure to enjoy building it. In spite of the cabinet's size, you'll find it breaks down into three, easily managed sections — case, stand, and a drawer box to go inside the case.

**Case.** I started by building the case. For the most part, the case is a box made up of several frame and panel assemblies (including the doors). Inside the case, you'll find a couple of shelves and a drawer box (see page 24). At the bottom of the

case are a pair of larger drawers that ride on full-extension slides.

**Frame and Panel.** The first things to build are the frame and panel back and side assemblies. When it came to the joinery, I chose a simple stub tenon and groove. This joint offers quite a bit of strength and is easy to cut on the table saw.

Since the joinery dimensions are the same for both the back and sides, you can save yourself some time (and avoid extra setups) by

## Gluing a Solid-Wood Frame & Panel

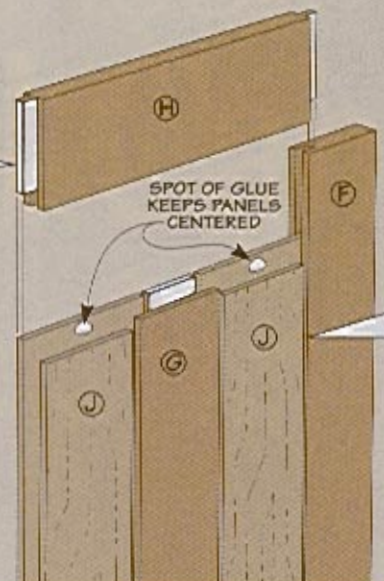
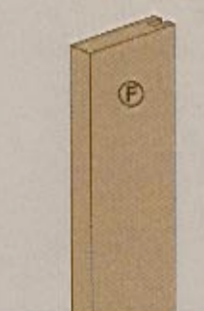
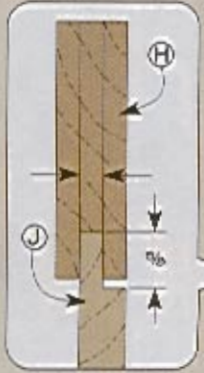

Stub tenon and groove joinery and frame and panel construction are pretty common — we use them all the time. But when the panels are made from solid wood, it adds a whole new twist.

The biggest thing to remember is that the solid wood panels will expand and contract across their

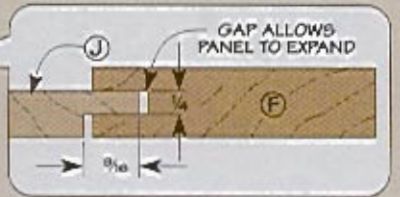

width with changes in humidity. To prevent the frames from breaking apart when this happens, I cut the panels a bit narrower (1/8") than the opening. This gives them a little breathing room to move.

This also means the panels can't be glued into the grooves. Instead, they'll need to float. But that poses a problem for keeping a consistent reveal on the panels. To overcome this problem, I held the panels in place with a centered dab of glue at the top and bottom. This will keep the panel centered while still allowing it to expand and contract.

2 FIGURE

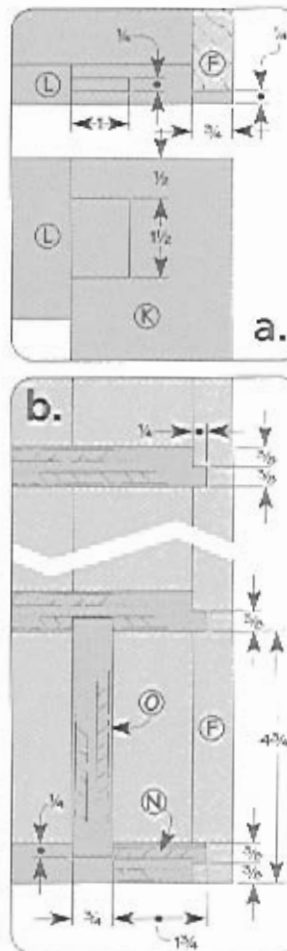
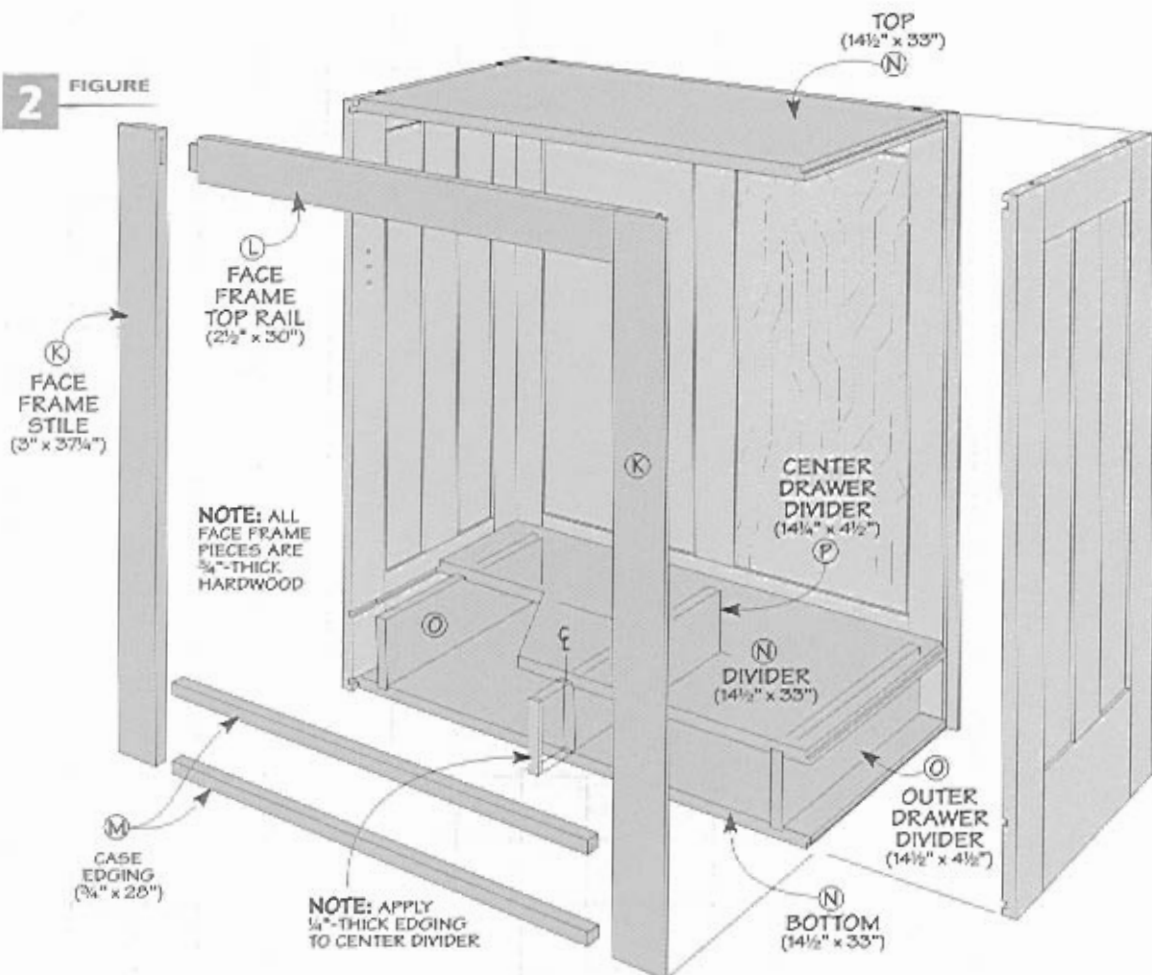

cutting all the joinery at one time. Note: The joinery in the doors uses the same dimensions as well. So you may want to take the opportunity to cut these parts now too. Take a look at page 21 for details.

There's one other thing to note about these assemblies. The panels are made of solid wood. So you'll need to account for this during glue up. The box on the opposite page will give you some pointers.

After completing the sides and back, the next step is to cut the joinery used to assemble these to each other (Figure 1a) and with the top, bottom, and divider. Here again, I stuck with basic joinery — rabbets and dados, as in Figure 2.

**Space for Drawers.** Before the case can be assembled, you'll need to cut and fit three vertical dividers that will create openings for a pair of drawers. These drawer dividers are held in dados cut in the divider and case bottom (Figure 2b).

**Face Frame.** Once the case was assembled, I turned my attention to

the face frame. This face frame is a little unusual in that it consists of only two stiles and a top rail.

The face frame stile and rails are joined with mortise and tenon joints. Take a look at the box below for a quick way to make this joint. The last thing to do before gluing up the

face frame is to cut a rabbet on each stile to hold the case sides. Doing this now makes it easier to control the parts on the table saw. And once assembled, the frame can then be glued in place. Then after gluing some edging on the exposed plywood edges, the case is complete.

## Square Mortise

Cutting the mortises in the face frame stile isn't really difficult. The only tricky part is making them consistently and quickly. To do this, I use a simple, two-step process.

It starts at the drill press. Most of the waste is removed with a brad point bit while an auxiliary fence guides the workpiece. In the upper detail you'll see how a drill bit can be used to set the fence.

After drilling out the waste, all that remains is a little clean up. Here, I use a chisel to smooth the sides of the mortise and square up the ends, as illustrated in the lower detail.

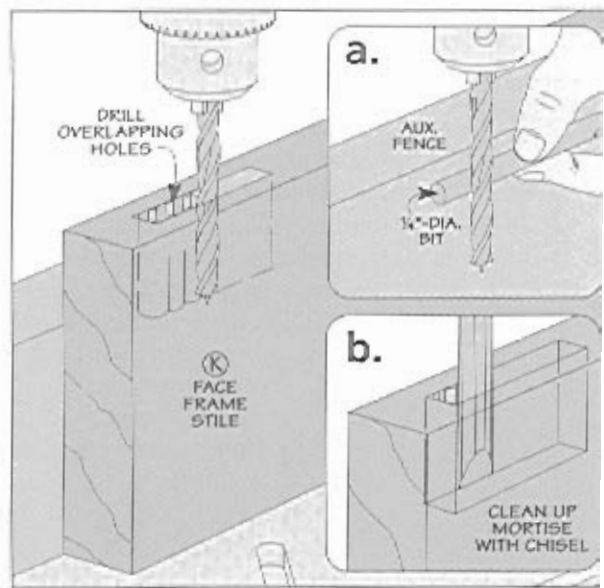

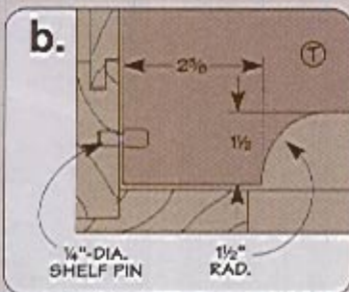
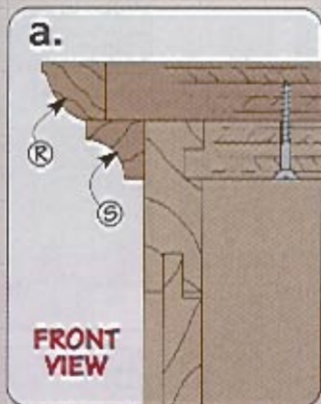

**3** FIGURE

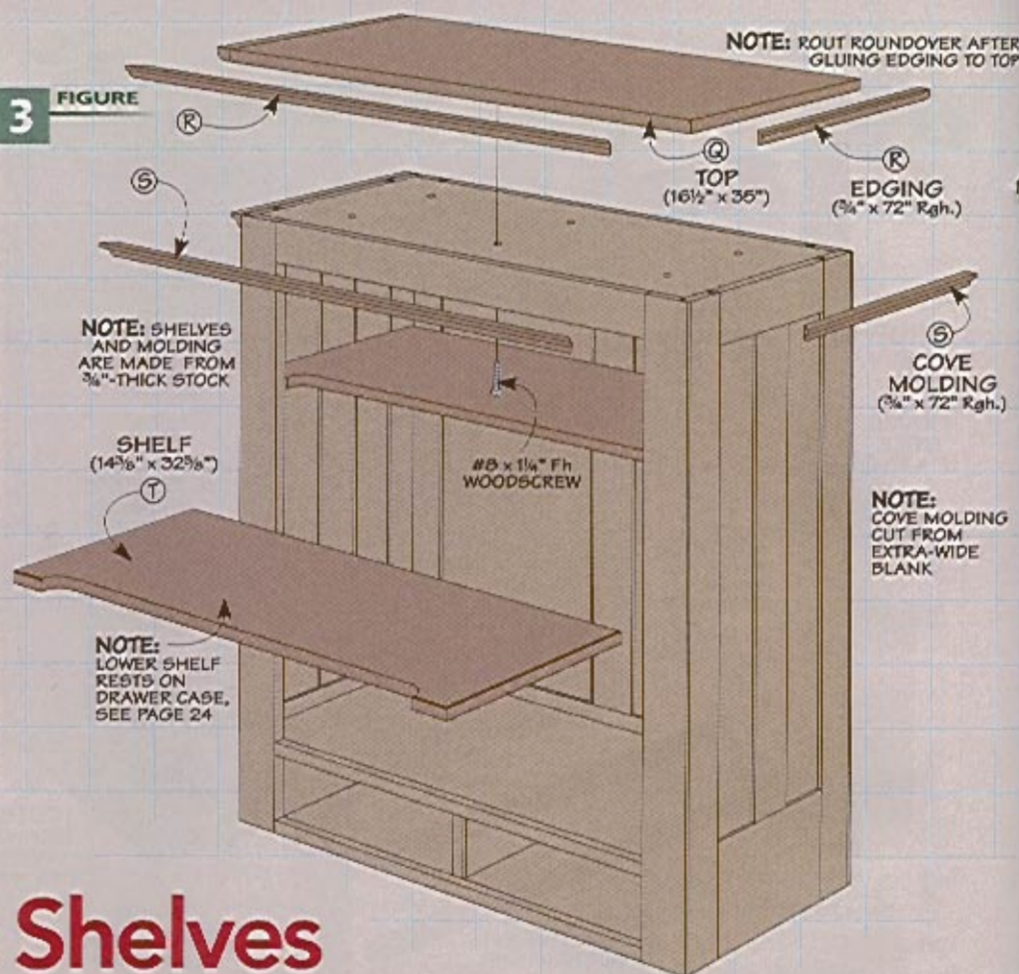

## making the Top & Shelves

At this point, the case is in pretty good shape. From here, you'll work on dressing it up, adding some organization, and closing it in.

**Molding.** I wanted to give the case a more "finished" look, so I added built-up, routed moldings to the top of the case. But routing thin moldings like this can be a bit challenging to do. However, there are a couple of things you can do to make it go a little easier. You can see them in the box at right.

**Top.** The first solution is used on the top, as shown in the left drawing. Here, I mitered and glued 3/4"-square edging to the plywood top panel *before* routing the roundover profile. This makes the workpiece large enough to easily shape on the router table. Once this step is complete, you can screw the top in place on the case.

**Cove Molding.** When it came to the cove molding that's applied to the underside of the top, I did things a little differently (right drawing). In this case, the cove is

routed on an extra-wide blank at the router table. The molding can then be ripped to width at the table saw.

**Shelves.** The next pieces to add are a pair of shelves for the inside of the case. The shelves are just solid wood panels, as in Figure 3. There are two things to note here. First, the shelves should be cut a little narrower than the case. This lets them

expand with seasonal humidity changes without binding.

The second thing to note is the shape of the shelves. The front edge of each shelf has a cutout. This cutout provides clearance for tools you might want to hang on the inside of the doors. The ends of the cutout are offset slightly from the inside edges of the face frame (Figure 3b).

## How-To: Rout Moldings

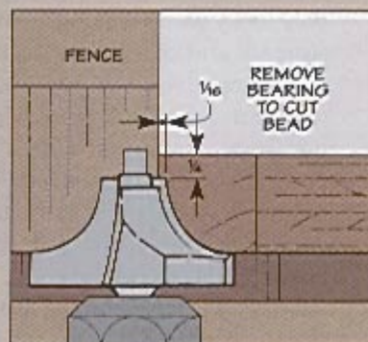

**Top Molding.** To cut the roundover in the top, glue the molding in place before routing.

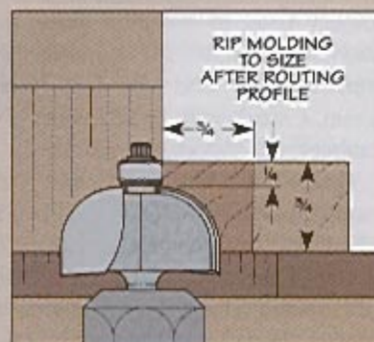

**Simple Cove.** For the cove molding, rout the profile in extra wide blanks and rip them to size.

### a. CROSS SECTION

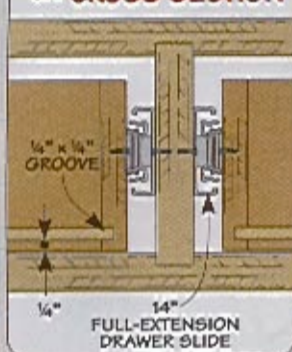

### b.

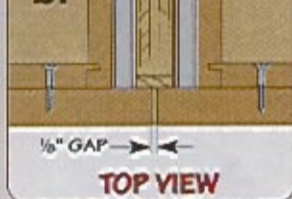

## 4 FIGURE

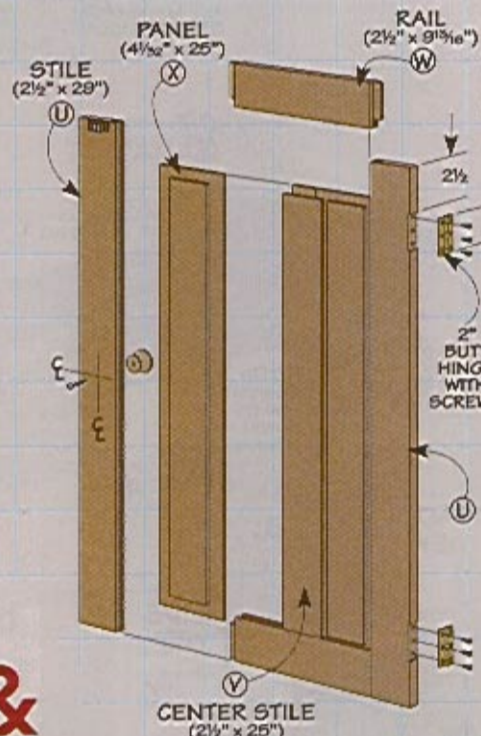

NOTE:  
SEE PAGE 26  
FOR ARTICLE ON  
FITTING INSET DOORS

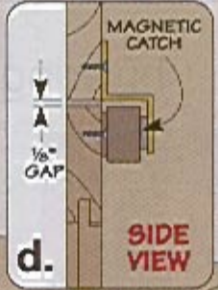
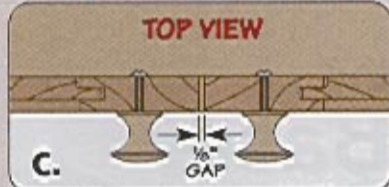

# a pair of Doors & Drawers

After the case itself is complete, there are still a few things left to add. The first of these are the doors. Like the sides and back, the doors are frame and panel assemblies, as shown in the drawing above. So building them won't be any different than the case assemblies that were built earlier.

**Gap.** There's one thing to point out about the doors. I built mine with a 1/8" gap on all four sides, as you can see in Figures 4c and 4d. This is a little larger than usual, but the larger gap creates a shadow line that makes the doors really stand out.

Regardless of the size of the gap, I always go about installing an inset door the same way. First, I mortise the hinges into the door to create the gap I'm looking for. Then, I match that gap around the other edges of the door.

Fitting inset doors can be a bit challenging. But there are a few tips that can make the process go a little smoother. You can learn more about it in the article on page 26.

**Hardware.** Once the doors are installed, you can attach the hard-

ware. I used a set of magnetic catches at the top of the case to keep the doors closed (Figure 4d). I decided to use cherry knobs that are stained darker to contrast with the fir used in the rest of the case.

**Drawers.** The final items to build are the drawers for the bottom of the case, as shown in Figure 4. The drawers are made with straightforward tongue and dado joinery. The box at right will give you a good idea of how to do the work. A 3/4"-thick false front is screwed to the drawer boxes.

The drawer box is built first. Then after attaching the slides, you can fit the false front. For a consistent look, I used the same gap around the false fronts as I used on the doors (1/8"). When sizing the false fronts, keep in mind that they'll need to overlap the middle divider in the case, as shown in Figure 4b.

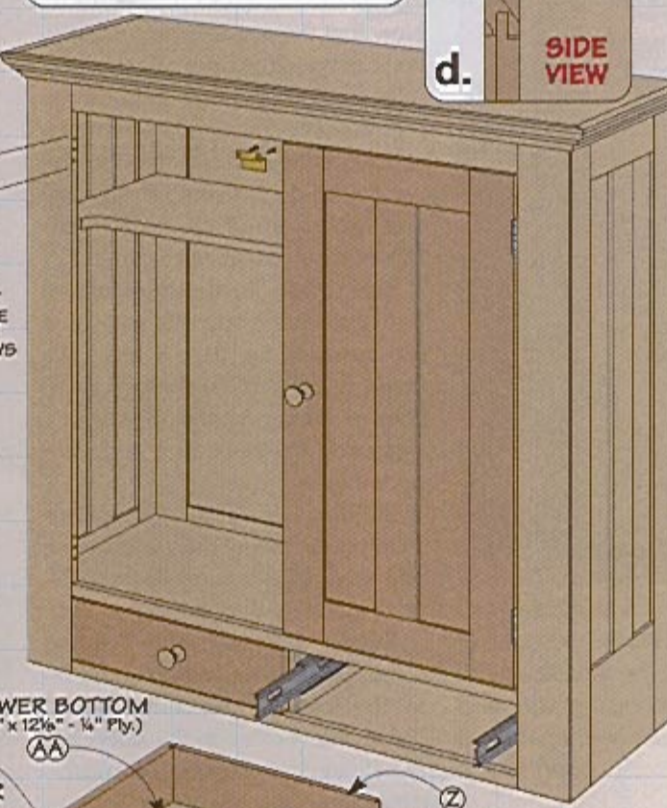

## Tongue & Dado

**Drawer Joinery.** When it came to building the drawers for the tool cabinet, I chose an easy-to-cut joint that adds a lot of strength. To make the joint, start by cutting a dado in the drawer sides, as you see in the left drawing. Then cut a matching tongue in the fronts/back. When the false front is attached, it actually strengthens the joint like a locking rabbet.

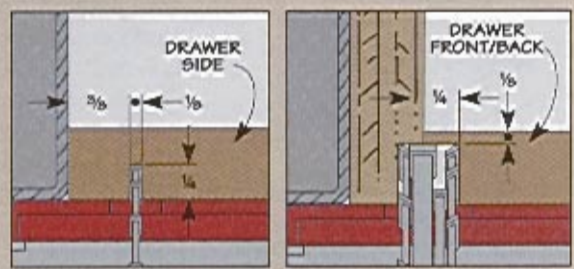

## building the Base



Now that the case itself is complete, you can build the stand. Because the fully loaded cabinet is going to be pretty heavy, the stand needs to be sturdy enough to support the weight. To do that, both the joinery and each part of the stand contribute to its overall strength.

**Solid Base.** In the drawings at right and on the opposite page, you can see how the base is built. It's made up of three separate assemblies — two ends and the drawer. The ends are built first and connected by stretchers.

Building a base like this requires solid parts. And all the parts for the end assemblies are made from 3"-thick glued up blanks.

**Strong Joinery.** After cutting these parts to size, you can move on to the joinery. Like I mentioned before, the joinery in the stand has to be rugged. So for this, I chose traditional mortise and tenon.

But these are no ordinary joints. They're pretty large compared to other furniture projects. Once assembled, this added size makes the joints very rigid and sturdy, as you can see in Figures 5b and 5c.

▲ **Knock-Down Base.** Drawbolts in the legs keep the base together and allow you to take it apart easily.

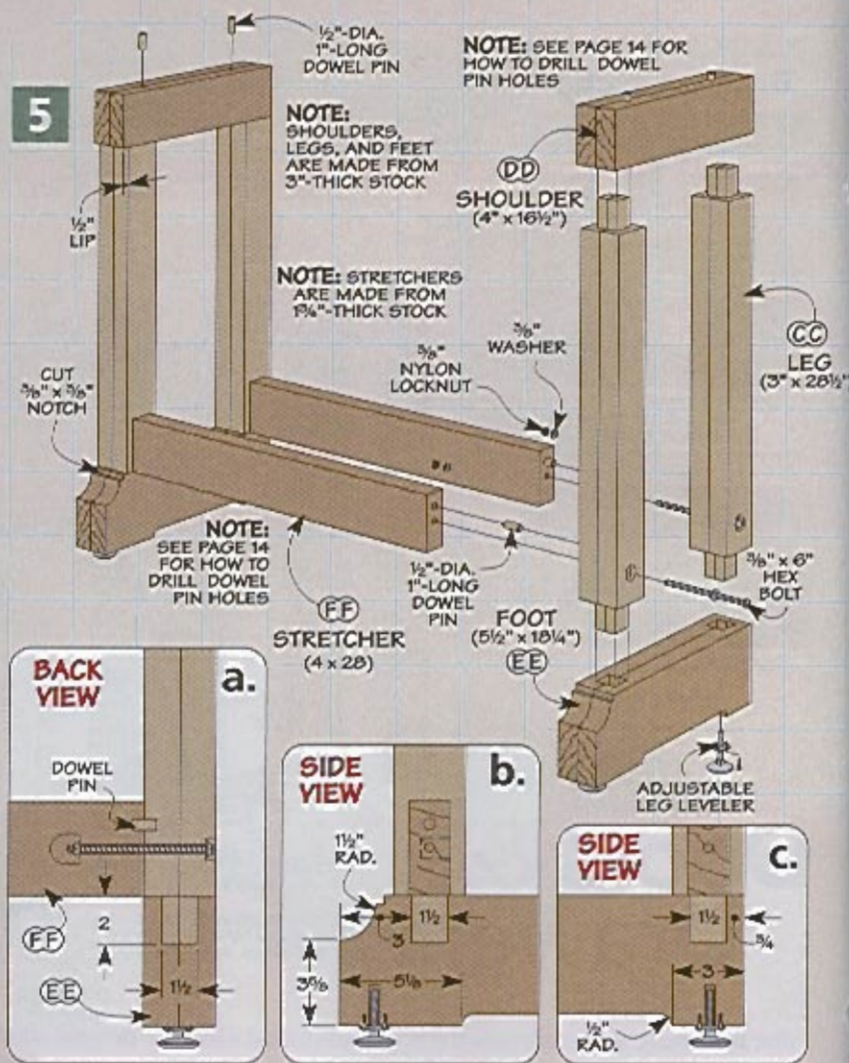

The mortises begin at the drill press with a Forstner bit and finish up with some chisel work. The box at the bottom of the opposite page will give you an idea of how it works. Once the mortises are complete, you can go on to cut matching tenons on the ends of the legs. A

## Drilling Guide

The drawbolt system used to connect the ends of the base and the stretchers is really pretty simple. The biggest concern is drilling all the holes accurately. That's where the drilling guide shown below comes in. Taking extra care to make the guide accurately means drilling perfect holes will be a breeze.

The first holes to drill are located in the stretchers, Figure 1. One hole will hold a dowel and the other is for the drawbolt. Figure 2 shows how to use the guide to drill the matching holes in the legs of the base.

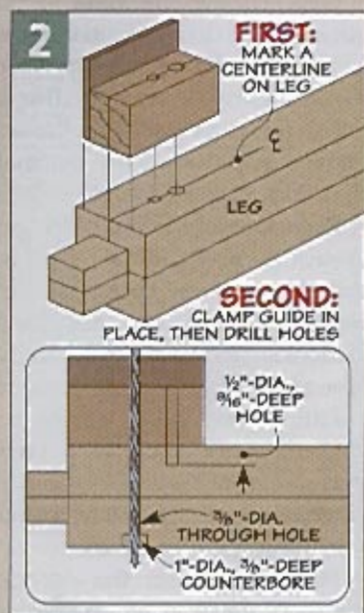
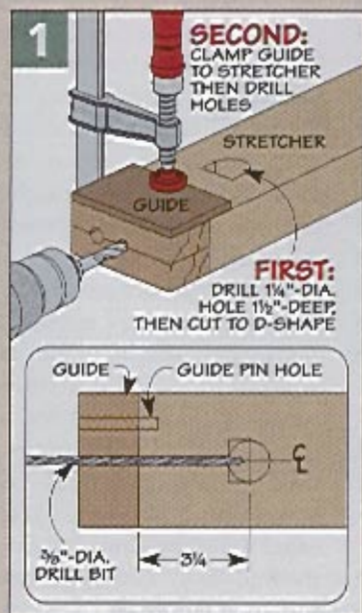
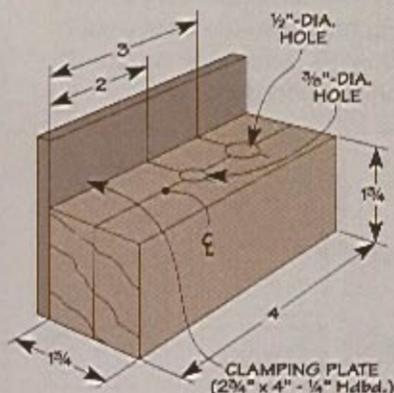

dado blade in the table saw will make quick work of the tenons.

**Feet.** That just about takes care of the end assemblies. But before you can glue the ends together, there are a few details on the feet to take care of. The box along the bottom of the page will give you some pointers for shaping these details. And finally, to keep the stand steady, I added a leg leveler in each corner.

**Stretchers.** When the feet are complete, the next step is assembling the two ends. Connecting the ends are two stretchers. Instead of using mortise and tenon joinery here, the stretchers are connected to the ends with drawbolts.

This method is often used on workbenches. There are two big advantages to this. First, it allows the stand to be knocked down for easier moving. Second, if the joint should loosen up, you can quickly snug it up with a wrench.

The drawbolt slips through the leg and into the end of the stretcher. There, a nut and washer are fit into a D-shaped hole to pull the joint tight, as shown in Figure 5. I drilled this cross hole in the back face of each stretcher. This hole in the back face keeps it hidden from view, as you can see in Figure 5a.

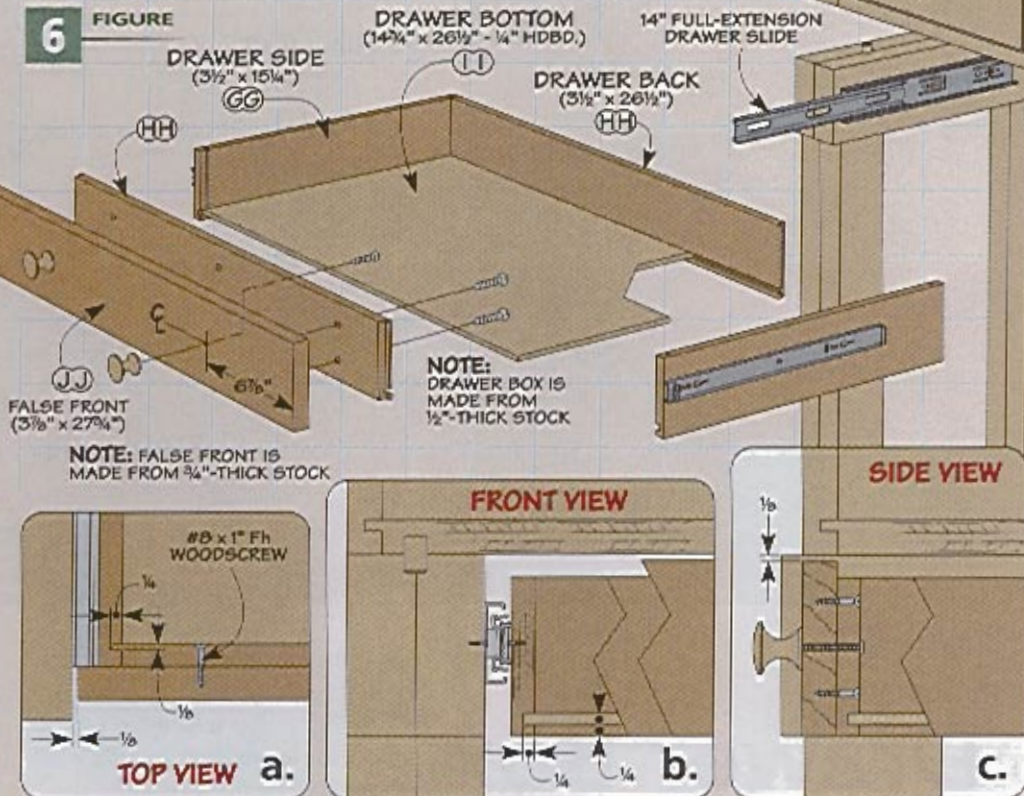

The key to making this work is to make sure the holes are drilled accurately. To do this, I used a drilling guide. You can read more about that in the box on the opposite page.

**Drawer.** At this point, the stand is pretty much complete. The last thing to make is a drawer. It's built just like the two in the cabinet, as in

Figure 6. To fit, the false front, I placed the cabinet on the stand. This way, I can size the front for a matching 1/8" gap (Figure 6c).

Finally, I drilled and installed a set of dowels in the top of the stand. The dowels will keep the cabinet from sliding off the top. Turn to page 14 to see how I did this.

## Making the Feet

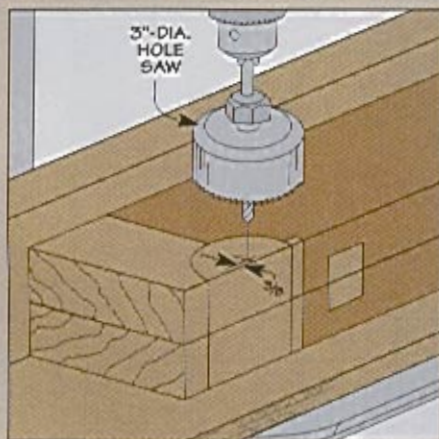

**Cutting the Notch.** To cut the round notch in the feet, use a hole saw and start with an extra long blank.

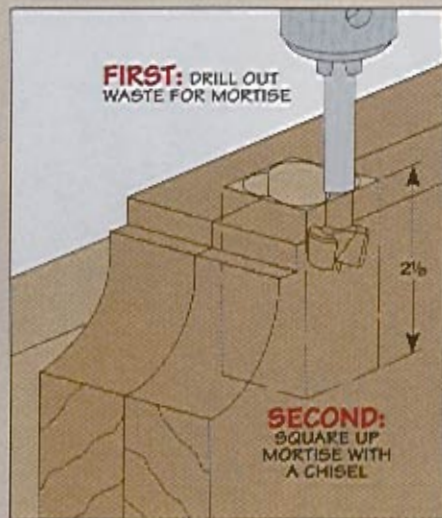

**Drilling Mortises.** Drill overlapping holes with a Forstner bit to rough out the mortise. Then square it up with a chisel.

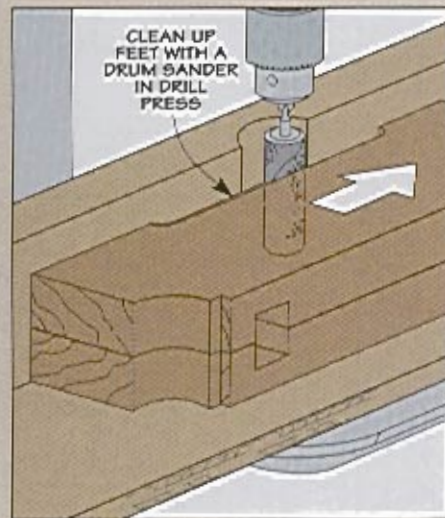

**Shaping the Feet.** After rough cutting the bottom for the feet, a drum sander and a notched fence will smooth it up.

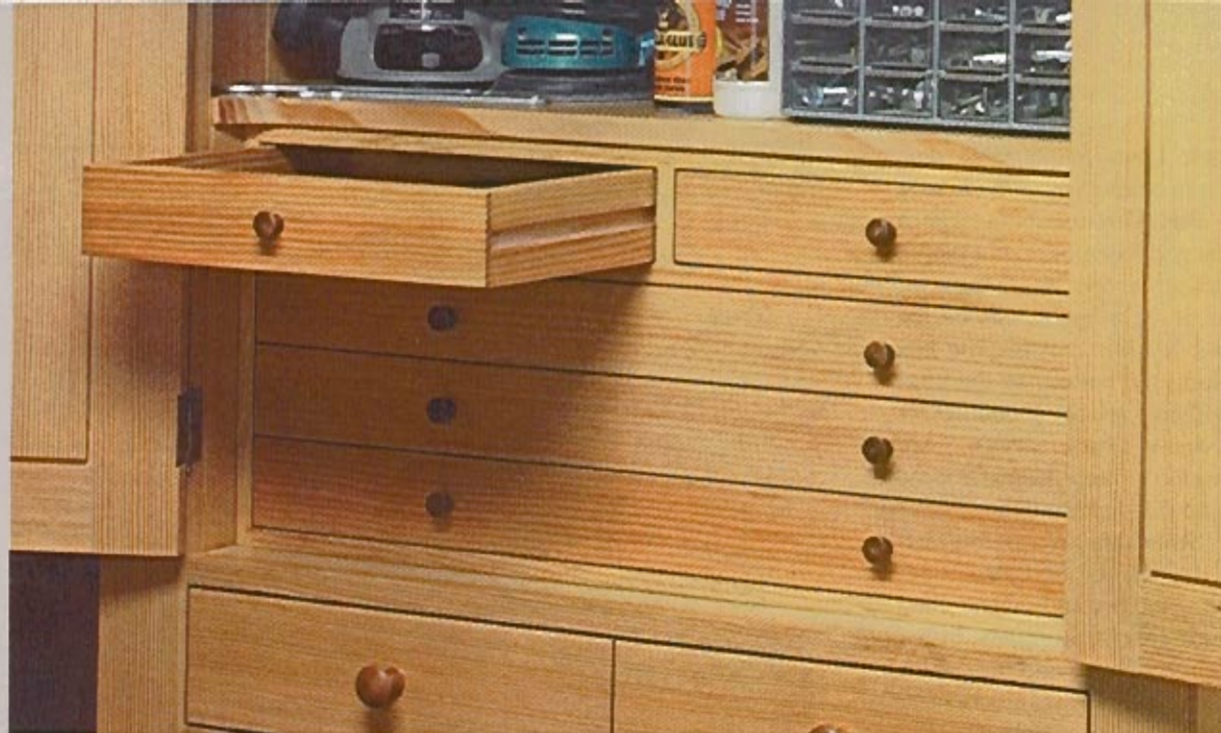

## building the Drawer Box

With all the space available in the heirloom tool cabinet, it's tempting to think that you can put all your tools in there with room to spare. But if you have a lot of smaller hand tools, this much open space may not be your best bet.

To keep track of (and protect) your smaller hand tools, you need

to add a little more organization. That's the job of this drawer box. It's designed to slip inside the cabinet under the lower shelf, but it'll work just as well setting on a shelf.

**Basic Joinery.** The construction for the box is pretty straightforward — just dadoes and rabbets. The case sides, divider, top, and bottom are glued up from 1/2"-thick stock.

As I mentioned before, the box is assembled with tongue and dado joints. This straightforward joint makes the assembly easy. The tongues and dadoes register each

piece to help square up the box, as you can see in Figures 7 and 7a.

**Top, Divider, and Bottom.** From here, you can cut the top, bottom, and divider. A tongue is cut on each end of these parts to fit the dadoes in the box sides. That's all you'll need to do to the bottom. The top and divider have one more step.

To accommodate a divider for the upper drawers, I cut a centered dado in the top of the divider and bottom face of the top. Unlike the dadoes in the sides, this one is sized to hold the full thickness of

### FRONT VIEW

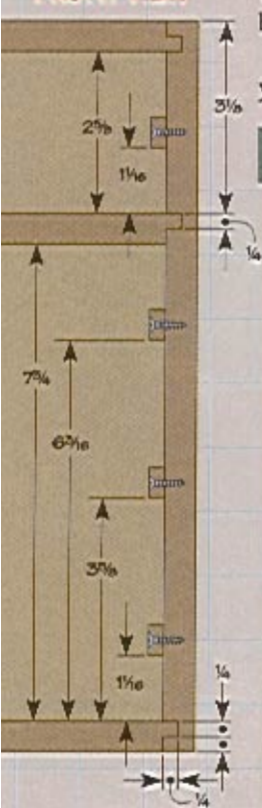

### 7 FIGURE

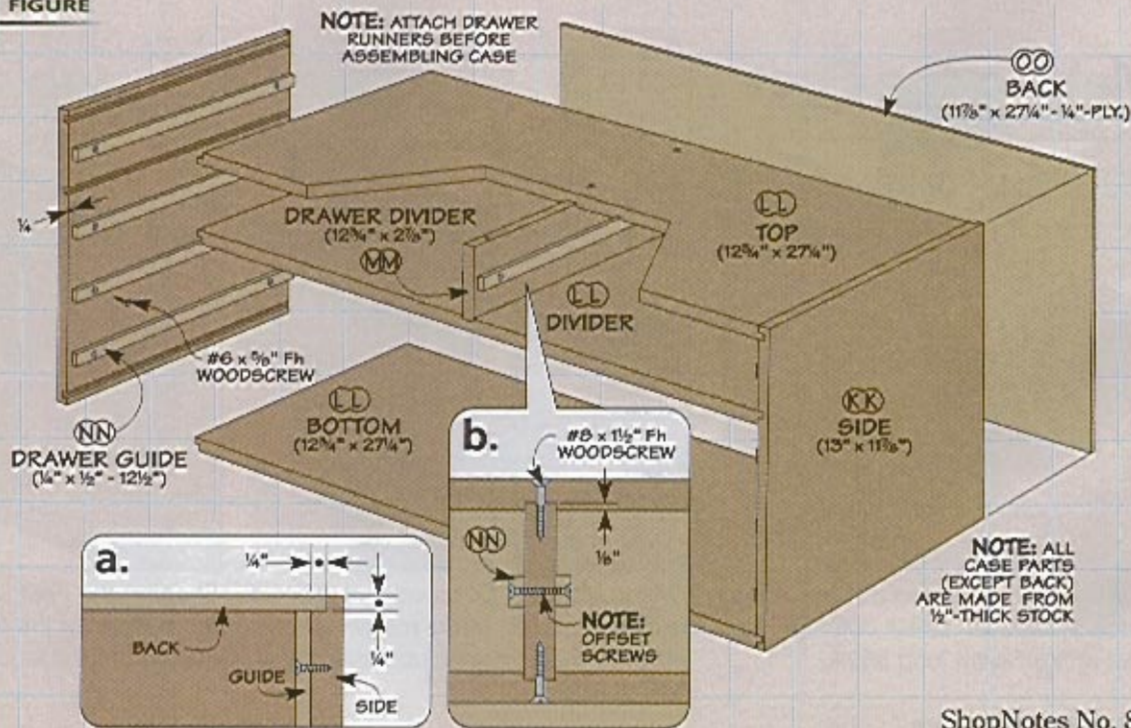



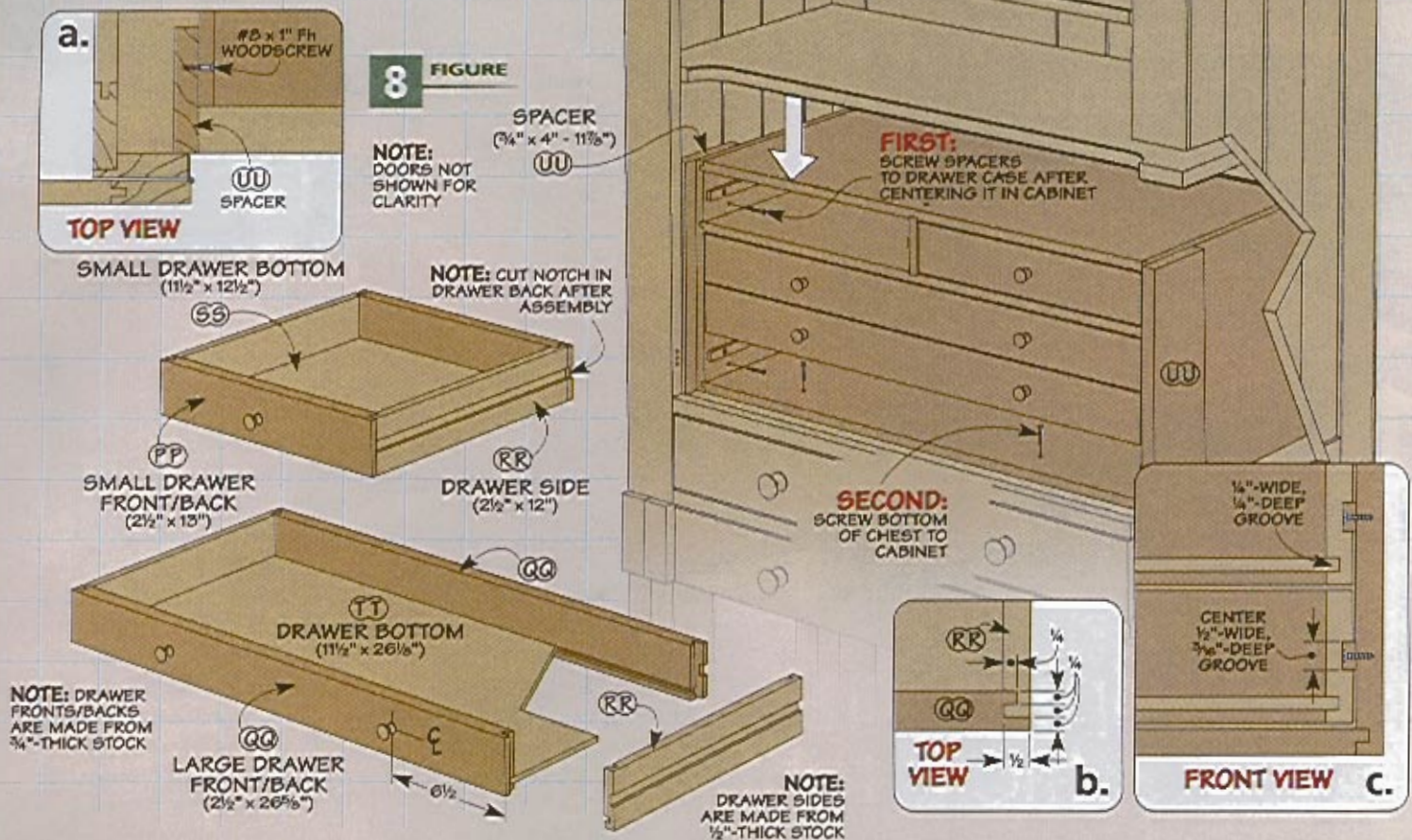

the drawer divider, as in Figure 7b on the opposite page.

**Drawer Runners.** There's one more thing to do before assembling the box. I cut and installed the drawer runners (Front View on the opposite page). The reason is that it's almost impossible to screw them in place after the box is assembled.

**Drawers.** All that's left to complete the box are the drawers, as shown in Figure 8. You won't find anything unusual in building them. The joinery for the drawers is shown in Figure 8b.

You'll notice there's a groove in the drawer fronts/backs and sides to hold the 1/4" hardboard bottom.

Another groove in the sides allows the drawer to fit over the runners.

**Spacers.** With the box complete, you can fit it inside the cabinet. A pair of spacers are screwed to the box to close up the gaps around the face frame. Finally, I screwed the box to the bottom of the cabinet to keep it from sliding around. 

## Materials & Hardware

A Back Stiles (2)	$\frac{3}{4} \times 3 - 37\frac{1}{4}$	W Door Rails (4)	$\frac{3}{4} \times 2\frac{1}{2} - 9\frac{1}{16}$	SS Sm. Drawer Btms. (2)	$11\frac{1}{2} \times 12\frac{1}{2} - \frac{1}{4}$ Hdbd.
B Back Center Stile (1)	$\frac{3}{4} \times 3 - 28\frac{3}{4}$	X Door Panels (4)	$\frac{1}{2} \times 4\frac{1}{32} - 25$	TT Lg. Drawer Btms. (3)	$11\frac{1}{2} \times 26\frac{1}{8} - \frac{1}{4}$ Hdbd.
C Back Top Rail (1)	$\frac{3}{4} \times 3 - 29$	Y Drawer Sides (4)	$\frac{1}{2} \times 3\frac{1}{2} - 14$	UU Spacers (2)	$\frac{3}{4} \times 4 - 11\frac{1}{8}$
D Back Bottom Rail (1)	$\frac{3}{4} \times 6\frac{1}{2} - 29$	Z Drawer Fronts/Backs (4)	$\frac{1}{2} \times 3\frac{1}{2} - 12\frac{1}{8}$		
E Back Panels (2)	$\frac{1}{2} \times 13\frac{3}{8} - 28\frac{3}{4}$	AA Drawer False Fronts (2)	$\frac{3}{4} \times 4\frac{3}{4} - 13\frac{1}{16}$		
F Side Stiles (4)	$\frac{3}{4} \times 2\frac{1}{4} - 37\frac{1}{4}$	BB Drawer Bottoms (2)	$13\frac{1}{2} \times 12\frac{1}{8} - \frac{1}{4}$ Hdbd.		
G Side Center Stiles (2)	$\frac{3}{4} \times 3 - 28\frac{3}{4}$	CC Legs (4)	$3 \times 3 - 28\frac{1}{2}$		
H Side Top Rails (2)	$\frac{3}{4} \times 3 - 11$	DD Shoulders (2)	$3 \times 4 - 16\frac{1}{2}$		
I Side Bottom Rails (2)	$\frac{3}{4} \times 6\frac{1}{2} - 11$	EE Feet (2)	$3 \times 5\frac{1}{2} - 18\frac{1}{4}$		
J Side Panels (4)	$\frac{1}{2} \times 4\frac{3}{8} - 28\frac{3}{4}$	FF Stretchers (2)	$1\frac{3}{4} \times 4 - 28$		
K Face Frame Stiles (2)	$\frac{3}{4} \times 3 - 37\frac{1}{4}$	GG Drawer Sides (2)	$\frac{1}{2} \times 3\frac{1}{2} - 15\frac{1}{4}$		
L Face Frame Top Rail (1)	$\frac{3}{4} \times 2\frac{1}{2} - 30$	HH Drawer Front/Back (2)	$\frac{1}{2} \times 3\frac{1}{2} - 26\frac{1}{2}$		
M Case Edging (2)	$\frac{3}{4} \times \frac{3}{4} - 28$	II Drawer Bottom (1)	$14\frac{3}{4} \times 26\frac{1}{4} - \frac{1}{4}$ Hdbd.		
N Case Panels (3)	$14\frac{1}{2} \times 33 - \frac{1}{4}$ Ply.	JJ Drawer False Front (1)	$\frac{3}{4} \times 3\frac{7}{8} - 27\frac{1}{4}$		
O Outer Dividers (2)	$14\frac{1}{2} \times 4\frac{1}{2} - \frac{1}{4}$ Ply.	KK Box Sides (2)	$\frac{1}{2} \times 13 - 11\frac{1}{8}$		
P Center Divider (1)	$14\frac{1}{4} \times 4\frac{1}{2} - \frac{1}{4}$ Ply.	LL Box Panels (3)	$\frac{1}{2} \times 12\frac{3}{4} - 27\frac{1}{4}$		
Q Cabinet Top Panel (1)	$16\frac{1}{2} \times 35 - \frac{1}{4}$ Ply.	MMDrawer Divider (1)	$\frac{1}{2} \times 12\frac{3}{4} - 2\frac{1}{8}$		
R Cabinet Top Edging (1)	$\frac{3}{4} \times \frac{3}{4} - 96$	NN Drawer Runners (10)	$\frac{1}{2} \times \frac{1}{4} - 12\frac{1}{2}$		
S Cove Molding (1)	$\frac{3}{4} \times \frac{3}{4} - 96$	OO Box Back (1)	$11\frac{7}{8} \times 27\frac{1}{4} - \frac{1}{4}$ Hdbd.		
T Shelves (2)	$\frac{3}{4} \times 14\frac{1}{8} - 32\frac{3}{8}$	PP Sm. Drawer Front/Back (4)	$\frac{3}{4} \times 2\frac{1}{2} - 13$		
U Door Stiles (4)	$\frac{3}{4} \times 2\frac{1}{2} - 29$	QQ Lg. Drawer Front/Back (6)	$\frac{3}{4} \times 2\frac{1}{2} - 26\frac{3}{8}$		
V Door Center Stiles (2)	$\frac{3}{4} \times 2\frac{1}{2} - 25$	RR Drawer Sides (10)	$\frac{1}{2} \times 2\frac{1}{2} - 12$		

tips and  
tricks for fitting

# Inset Doors

Fitting an inset door perfectly is just a matter of taking care of the details.

SIZE  
VERTICAL  
SUPPORT  
TO POSITION  
DOOR  
FLUSH  
WITH  
FACE  
FRAME

■ Installing doors on a project can be a challenge — especially inset doors that fit inside the frame of a cabinet. But when the gap is nice and even, like you see in the photo at right, the result is worth the effort.

So how do you go about fitting an inset door with a consistent gap? Well, over the years, I've found a few ways of doing this that give me great results without a lot of hassle.

As I mentioned, a consistent gap is the key to a great looking inset door. And this may sound a little odd, but to start with, I don't worry about the gap at all when I build the doors.

Instead, I measure the opening in the cabinet and then build the doors to fit snug — just fill the opening so there aren't any gaps.

**Determining the Gap.** Once you have the doors built, you can start thinking about the size of the gap. Now, there aren't any set rules for what size gap you should have around the doors of a cabinet.

I like the look of a  $\frac{1}{16}$ " gap for most small to medium-sized doors. But for larger doors, like the ones in the tool cabinet shown above, a  $\frac{1}{8}$ " gap is just about right.

**The Hinges.** Once you've decided on the gap, you need to think about the hinges you're going to use and how to mount them. In most cases, the hinges are thicker than the gap you're looking for.

This means you'll need to mortise the hinges into the edge of each door. And that's the key to controlling the gap around the door.

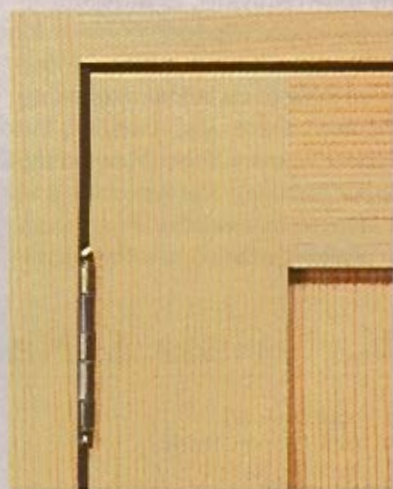

▲ **Consistency.** An even gap around the edges highlights a perfectly fit inset door.

To figure the depth of the mortises, you need to measure the thickness of the hinge barrel. Then just subtract the amount of the gap you want. What's left over is the depth of the mortises you'll need to cut.

Once you've cut the mortises in the door, you can install the hinges. Since you'll end up putting on and removing the door several times as you work on the fit, it's all too easy

▲ **Door Supports.** A set of T-shaped supports like the one shown above holds the door of a cabinet in position while you work.

to break off one of the soft brass screws in the process. Instead of worrying about this, I use a single steel screw in each hinge leaf while I do all the fitting work. Once everything is just right, you can reinstall the doors using the brass screws.

While I'm at it, I take the time to mark my hinges so I'll know exactly where they go on the project. Fitting a hinge to one location and then installing it in another can change the fit enough so the gaps don't look quite right. You can see how I keep track of where each hinge goes by checking out the photo at right.

**Mounting the Door.** The next step is to mount the door to the cabinet. The tricky part here is holding the door in position while you locate the hinges.

To give myself an extra "hand," I like to make a set of supports out of some plywood scraps, as in the margin and main photos on the opposite page. The supports are sized so when the door is in place, the face of the door is flush with the face frame of the cabinet.

Supporting the door solves one problem, but there's another one to

be aware of. You need the door closed to see if it's flush with the face frame. But the door needs to be open to drill the holes for the hinge.

So how do you keep the hinge in place without any screws? The answer is carpet tape.

You can see how this works in the main photo on the opposite page and in the drawing below. After sticking a couple pieces of carpet tape on the inside edge of the face frame where the hinges will hit, press the door tight against edge. Doing this "mounts" the hinges to the cabinet.

With the hinges "mounted," you can carefully swing the door open and drill the hinge holes in the cabinet. To ensure the hinge holes are drilled perfectly centered, I like to use self-centering drill bits, like you see in the lower margin.

**Check the Gap.** At this point, there should be a small, consistent gap along the hinged edge of the door. If there's not, this is the time to work on it.

If the gap is a little wider than you'd like, you'll need to make the mortises in the door just a little deeper. But if the gap is too narrow



**Marking Hinges.** To keep track of where each hinge and door goes, mark the hinge leaf, door, and cabinet with a number. The "D" lets me know to screw that hinge leaf to the door.

or if it's tapered from top to bottom, you can correct this by shimming one or both hinges.

**Final Trimming.** Once you're satisfied with the gap along the side of the case, the hard work is pretty much over. All that's left now is to trim the top, bottom, and center of the door to match.

To start this, I simply measure in from the edge of the face frame and mark the top and bottom of each door with a layout line that matches the gap along the hinge side of the door. Then I sneak up on the lines, checking the gap by reinstalling the door after each cut.

Before establishing the gap where the two doors meet in the center, you'll first need to install the other door.

This is just a matter of repeating the process.

Once you have both doors installed, you can use a hand plane to trim the edge of each door. This way, you don't have to worry about removing too much material. To keep the gap centered, be sure to remove the same amount of material from each door.

With the doors trimmed to final size, all that's left to do is mount them to the cabinet. This time, using all the brass screws. 



**▲ Self-Centering Drill Bit.** Drilling a perfectly centered hole for your hinge screw is easy with a self-centering drill bit like the one shown here.

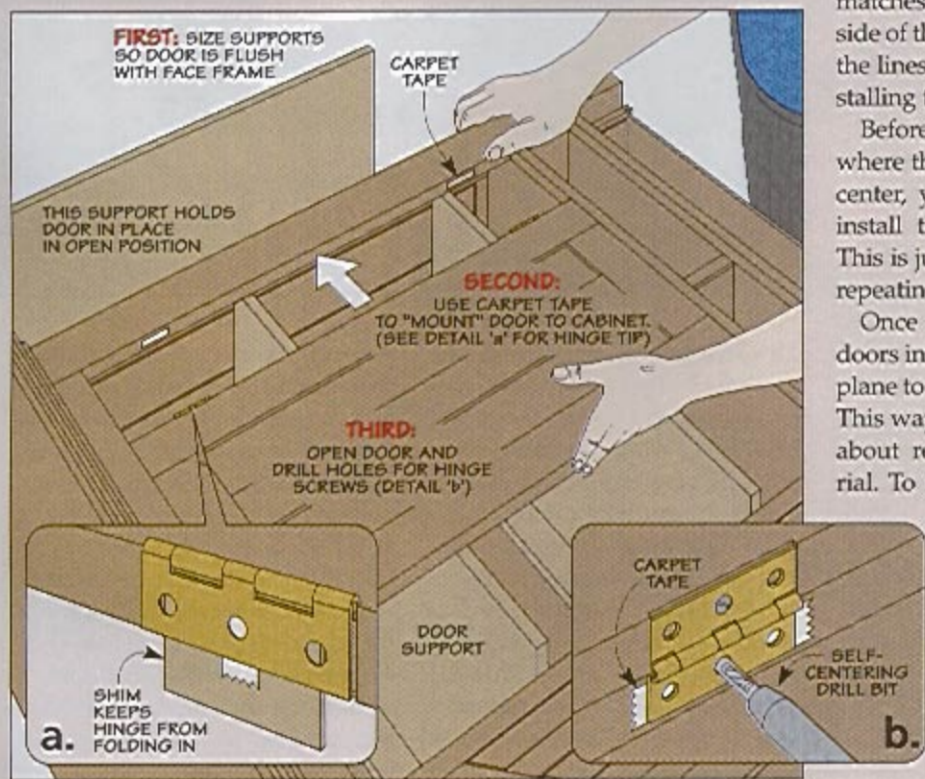

# knock-down Wall Shelf

When it comes to shop storage projects, I'm all for keeping things as simple (and inexpensive) as possible. But this doesn't mean you have to settle for something that's slapped together.

Take this knock-down wall shelf for example. It's made up of just a few boards and can be built in a weekend. But it's constructed with solid, traditional joinery — wedged mortise and tenon joints.

The result is a wall shelf that's not only challenging and satisfying to build — but sturdy enough to hold just about anything.

**Joinery.** One of the ways I kept the construction simple was the method I used for making the mortises that hold the shelves. If you take a look at the main drawing on the opposite page, you'll see that each side is glued up out of three pieces. This allows you to cut the mortises on the table

saw before gluing up the sides, instead of drilling and chiseling them out by hand. For more, see the box on the opposite page.

Once the sides are glued up, you can lay out the curves on the ends



Put your joinery skills to the test by building this traditional and practical wall shelf.



*Wedged mortise and tenon joints hold the shelf together without any glue (see page 30).*

of the side pieces. I cut these on the band saw, but you could also use a jig saw or even a coping saw.

**Shelves.** With the sides complete, the next step is to make the shelves. If you take a look at the upper right drawing on the opposite page, you'll see that there are four shelves. All four are joined to the sides with through tenons. But the tenons on the top and bottom shelves are longer and are locked in place by wedges. To keep things simple, however, I started off by

making the tenons on all four shelves exactly the same. (See the article on page 30 for more information on making the tenons.) Then I trimmed the tenons of the two middle shelves so they would stand proud of the sides by  $\frac{1}{4}$ " once all the parts were assembled.

**Wedged Tenons.** The tenons on the top and bottom shelves each get a tapered mortise that holds a wedge. The trick here is to position the mortises so that the wedges will pull the shelves up tight to the

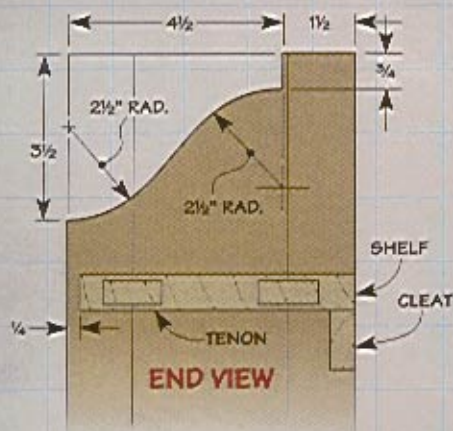

sides. Here again, you'll want to take a look at the article on page 30 for more.

When it came to making the wedges, I found it helpful to start by cutting them a little oversized at first and then paring them down gradually with a chisel until they slid into place. You're aiming for a tight fit without having the round part of the wedge bottom out against the tenon (see margin photo on opposite page).

**Cleats.** The last parts to make are a pair of cleats. These are simply glued to the underside of the top and bottom shelves, flush with the back edges. Although the cleats do add a little strength to the shelves, their real purpose is to simply provide a place to screw the shelf to the wall.

**Assembly.** The last step is to put everything together. The four shelves are simply captured in between the sides without any glue. Then the wedges are slipped in place to hold everything together. One word of caution here, though. When you're installing the wedges, just push them in by hand (rather than using a mallet). If you use too much force, you're likely to split the wood at the end of the through tenons. 

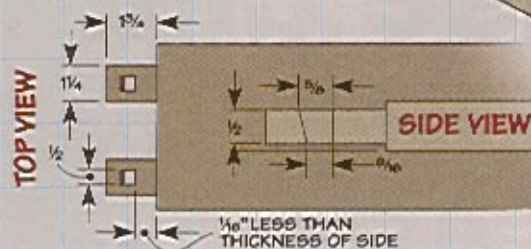
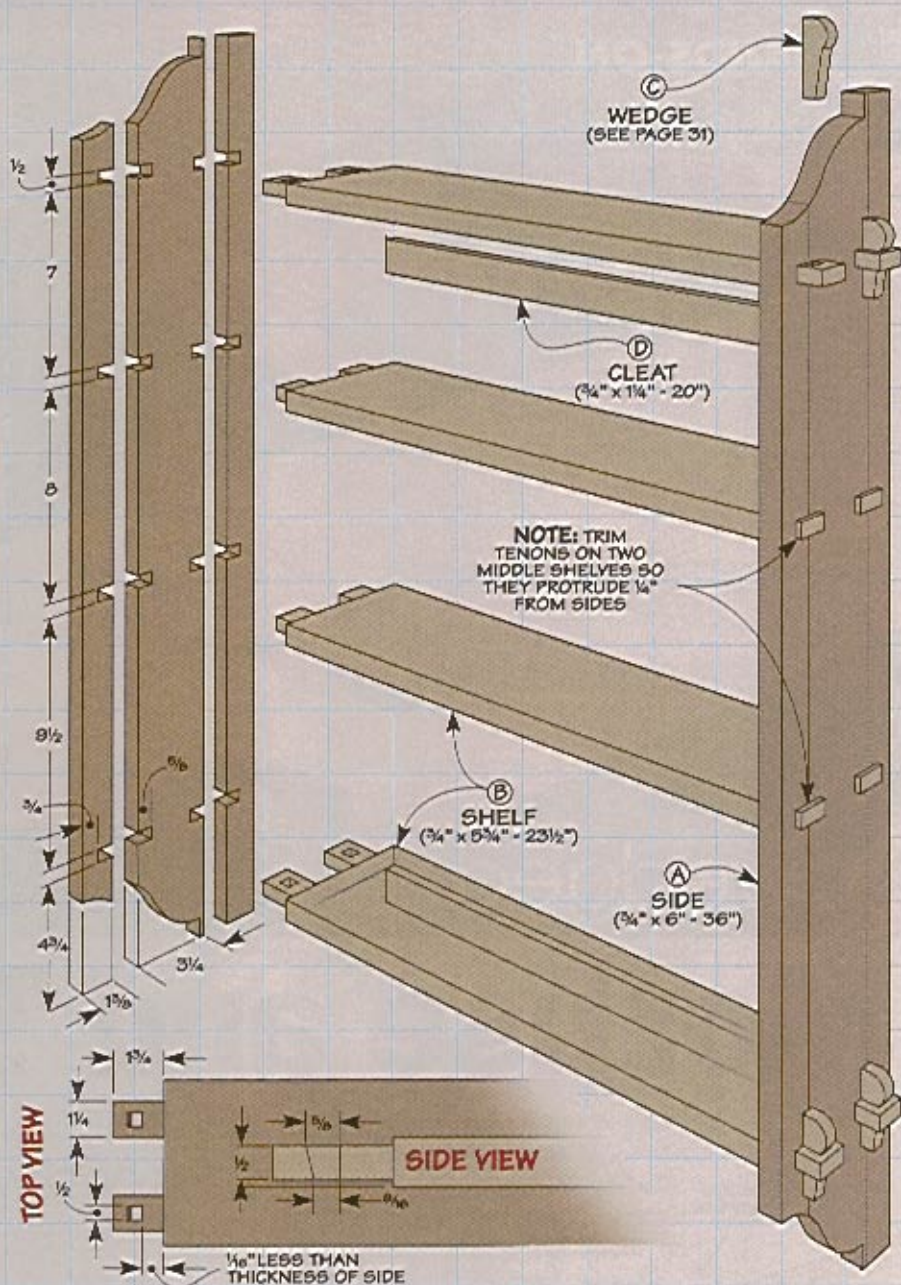

## Making the Tenons

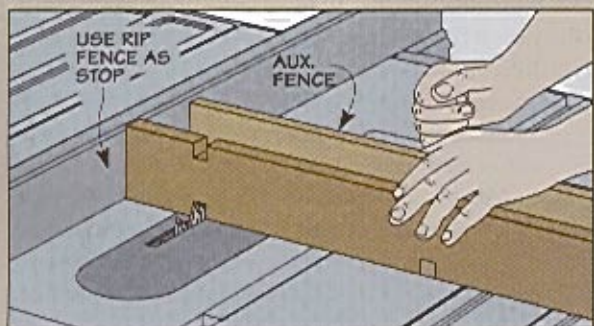

▲ **Cut Notches.** Using a dado blade and the rip fence as a stop, cut matching notches in the pieces that make up each side of the wall shelf.

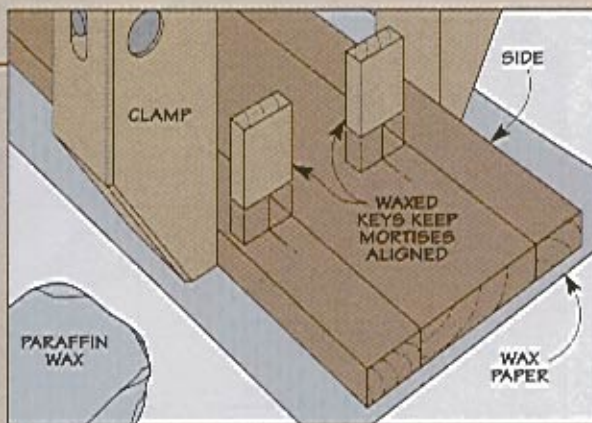

▲ **Glue Up the Sides.** Waxed hardwood keys help to keep the mortise notches aligned while gluing up the sides of the wall shelf.

**SHOP TIP**

NEW Department!

# HANDS-ON Technique

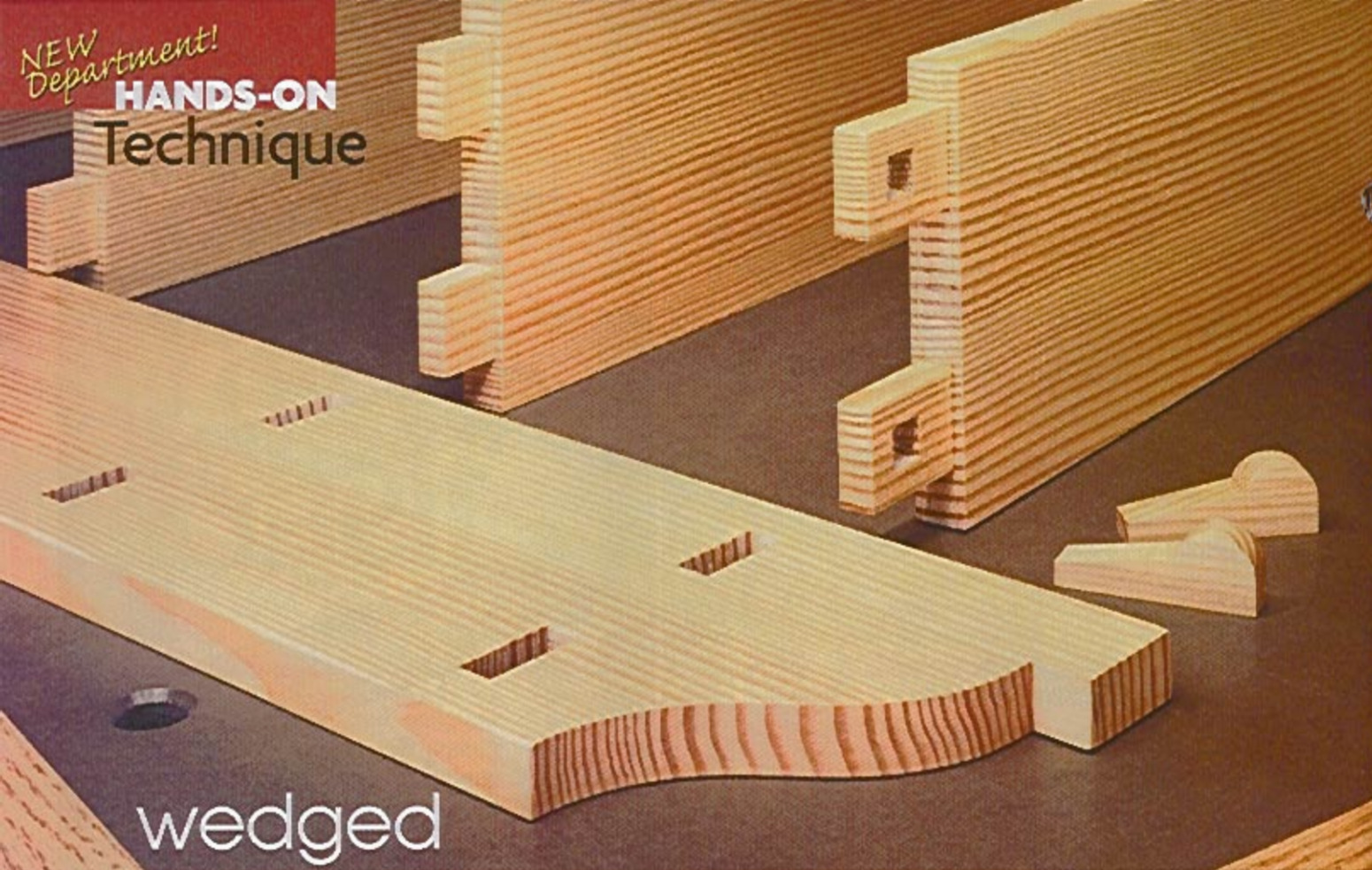

wedged

## Mortise and Tenon

Learn the secrets to making this traditional woodworking joint.

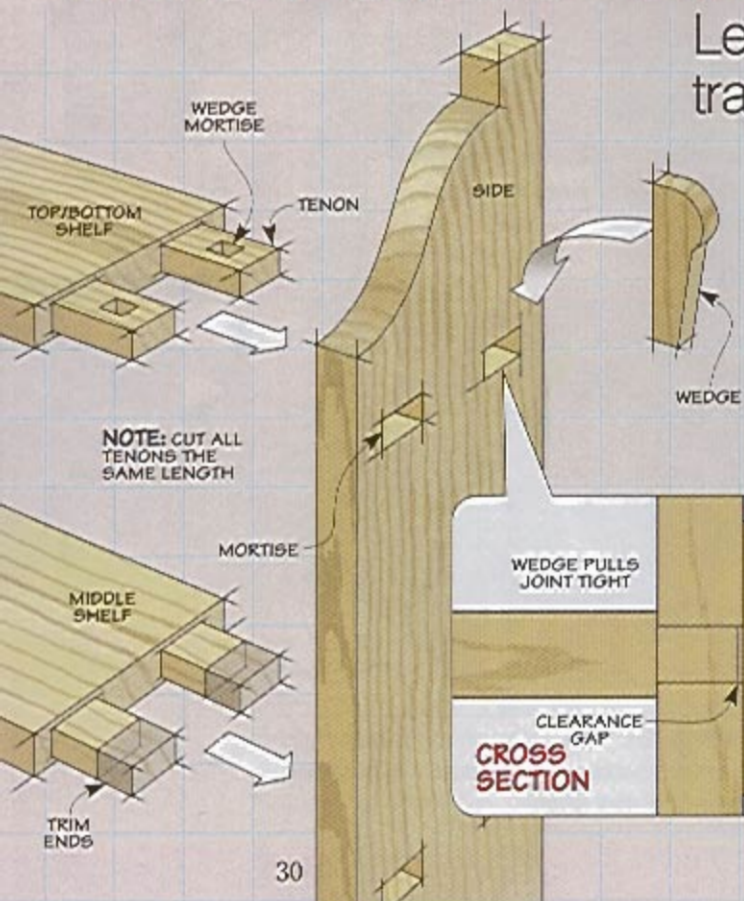

■ You don't have to be a woodworker to understand how a wedged mortise and tenon joint works — one look is all it takes. The tenon passes clean through the mortise and is locked in place by a simple wedge.

But *making* a wedged mortise and tenon joint can be a little more complicated. Because these joints don't rely on glue for their strength, it's all the more important to make sure the pieces fit together properly. Fortunately, this isn't all that difficult. Shop Note: This article shows how we made the joints for the Knock-Down Wall Shelf (page 28). But the procedure is similar for most other wedged mortise and tenon joinery.

**Mortises** – The first step to making this joint is to create the mortise. I made the mortises for the wall shelf on the table saw (see the box on page 29 for more). But no matter what method you use for making the mortises, the important thing is to keep them as square and accurate as possible. Otherwise, you'll end up with noticeable gaps around the tenons.

**Tenons.** Once the mortises are complete, you can start on the tenons. To make the tenons, I began with the cheek cuts, as shown in Figure 1. The goal here is to establish the thickness of the tenon by removing a small amount of material from each face of the workpiece. To do this, I used a simple tenon jig to hold the workpiece while making the cuts.

Then to create the shoulders of the tenons, I made multiple passes to remove the waste from the sides of the tenon (Figure 2). An

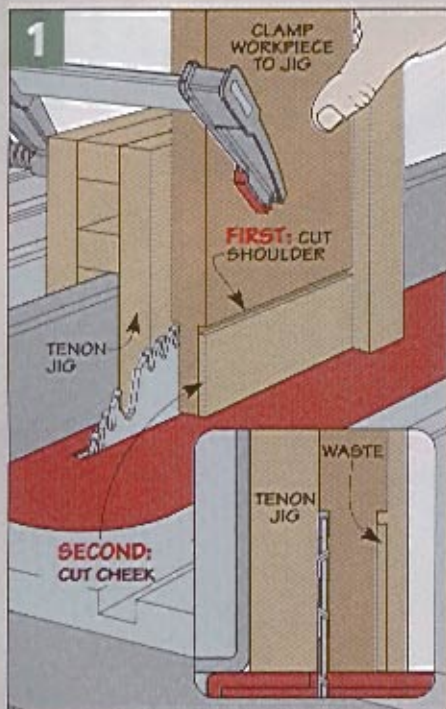

auxiliary fence attached to the miter gauge helps support the workpiece.

### Wedge Mortises.

After you've cut all the tenons, you're ready to start making the mortises for the wedges.

There's just one thing to keep in mind when laying out these mortises. You want to locate them so they end up slightly behind the outer face of the side pieces of the wall shelf, as shown in the detail drawing on the opposite page. This allows the shelves to be drawn up tight against the sides when the wedges are seated in place.

If you take a look at the detail drawing at right, you'll see that each mortise is tapered on one face. This allows the wedge to lock securely in place without any

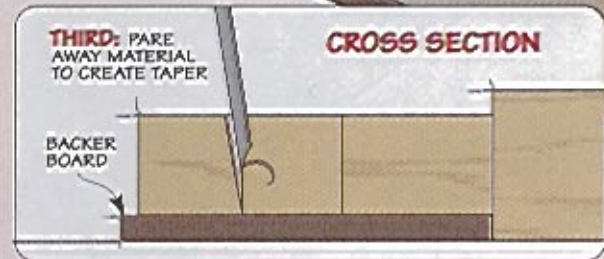
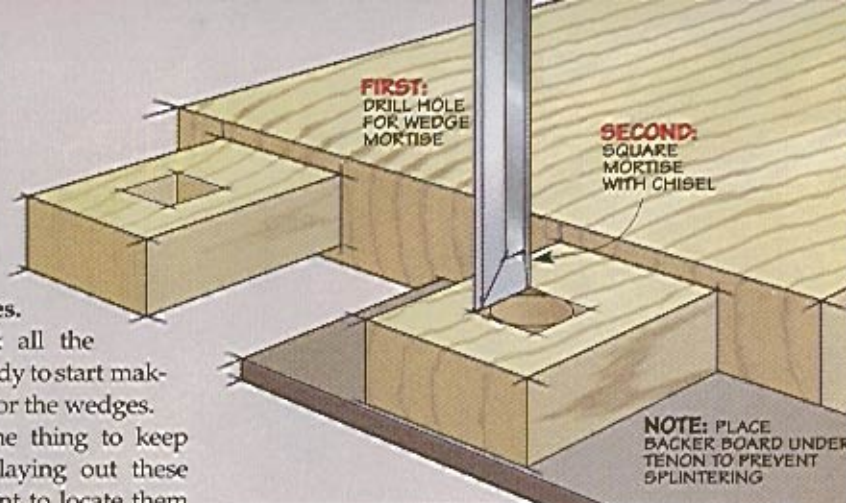
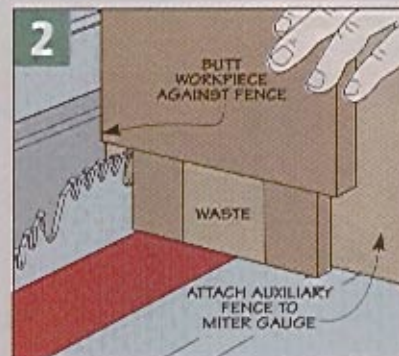

glue. But it's easier to start by making square, straight-walled mortises. I did this by drilling out the waste and then squaring up the sides with a chisel, see main drawing above.

To taper the mortises, I used a chisel to shave a little off the outer face of each mortise. Slice away the material at an angle, taking light cuts until you've pared back the top edge of the mortise by  $\frac{1}{16}$ ". Finally, you'll need to make and fit the wedges. For more on this, see the box below. 

## Hold it Together: Wedges

When it comes to making the wedge for a mortise and tenon joint, the important thing is for the taper of the wedge to match the mortise so it seats properly. I've found that the best way to do this is to start by cutting the wedge slightly wider than necessary. Then with a sharp chisel, I shave off material as needed to fine tune the fit.

To make the wedges for the Wall Shelf, I started with an extra-long blank and cut the tapered faces on the table saw. Then you can cut the wedges free from the blank with a band saw or scroll saw.

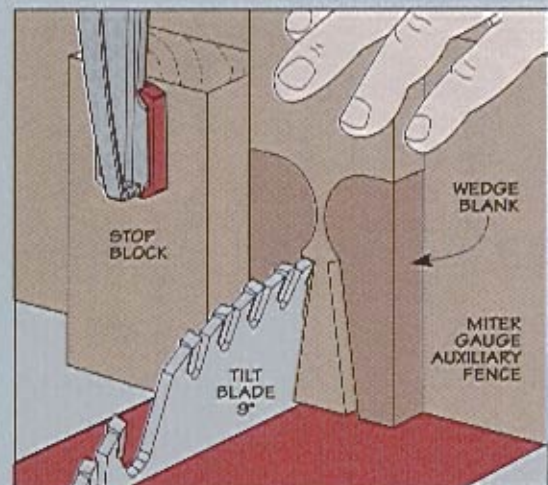
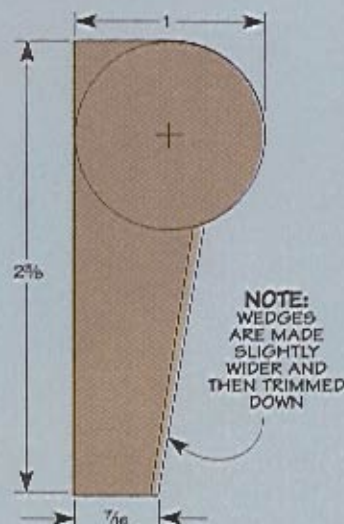

best-built jigs & fixtures

# shop-built Router Jointer

With just a router and a flush trim bit, you can joint perfectly smooth edges that are dead-on straight.



# Exploded View Details

OVERALL DIMENSIONS:  
12"D x 30"W x 9½"H  
(W/O ROUTER)

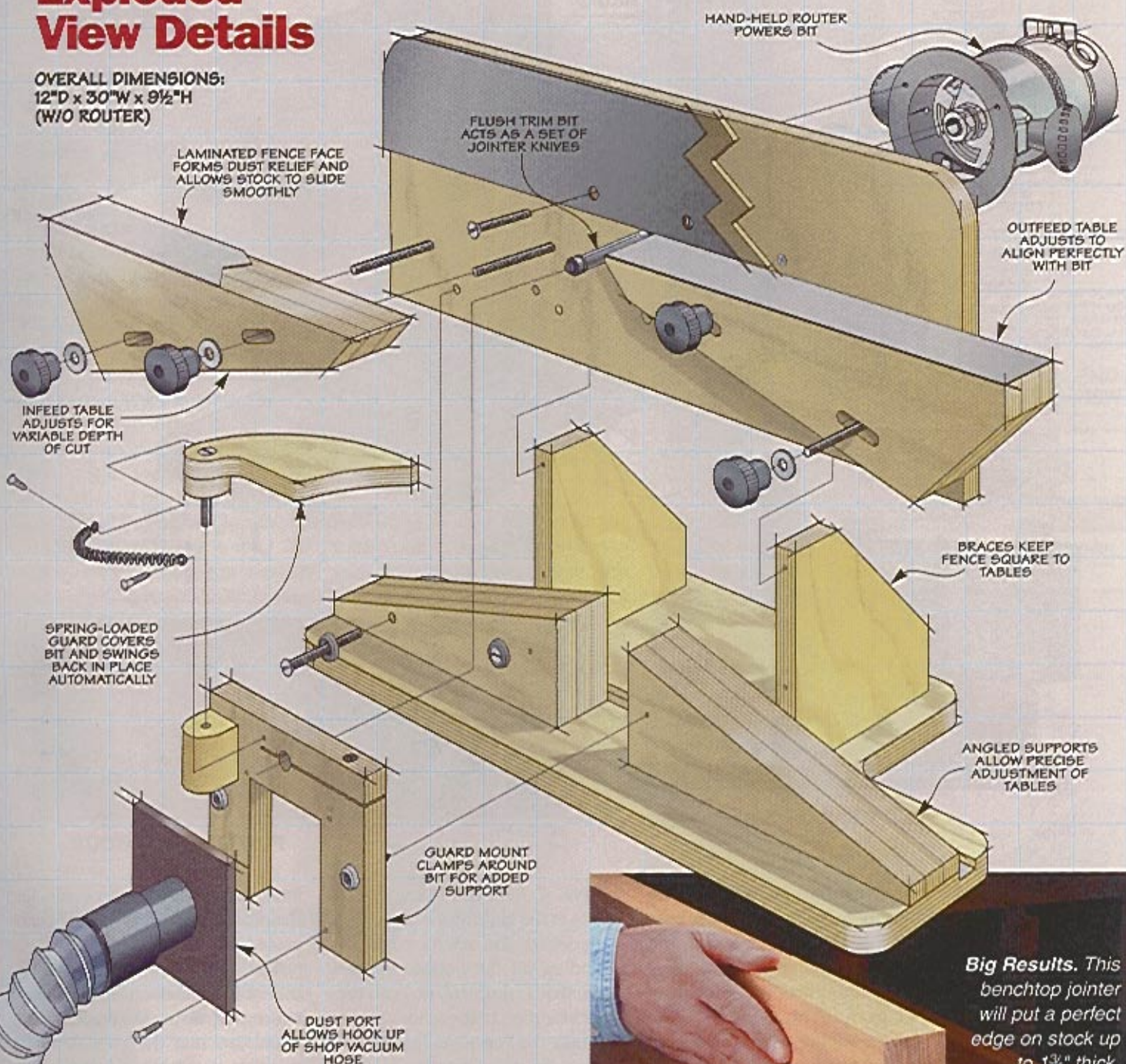

**Big Results.** This benchtop jointer will put a perfect edge on stock up to 1¾" thick.

## Hardware

- (4) ¼"-20 Through Knobs
- (4) ¼" Washers
- (4) ¼"-20 x 3¼" Carriage Bolts
- (1) ¼" O.D. x 1⅞" Spring
- (2) ¼" Pronged T-Nuts
- (2) #8 Finish Washers
- (2) #12 Finish Washers
- (2) ¼" x 3" Fh Machine Screws
- (6) #6 x ¼" Rh Woodscrews
- (15) #8 x 1½" Fh Woodscrews
- (1) ¼" x 2" Fh Machine Screw

# building the Base

**1** FIGURE

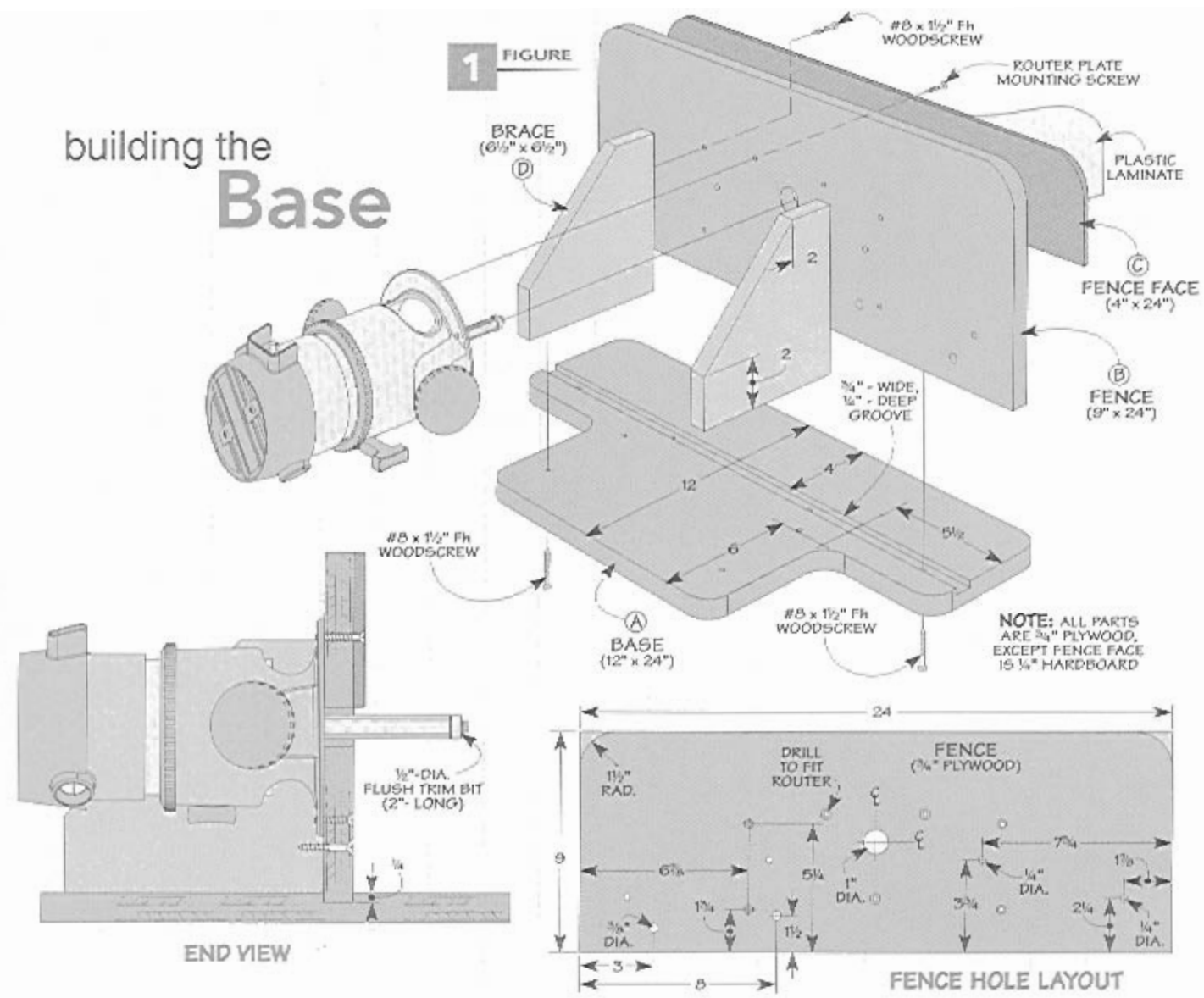

As you can see in the drawing above, there isn't much to the base that supports the router and tables of the jointer. In fact, there are only four parts, and they're all made from  $\frac{3}{4}$ " plywood — a base plate, a tall fence with a laminated face, and two braces.

**Start with the Base.** The base is nothing more than a rectangular piece of plywood with a groove cut in it to accept the fence. After cutting the

groove, I removed some of the waste at the back of the base. Then I removed the sharp edges by rounding all the outside corners. Once that's complete, you can turn your attention to the fence.

**Make the Fence.** As I mentioned earlier, the tall fence has a laminated face. This is just a piece of hardboard covered in plastic laminate, as illustrated in Figure 1 and the End View above.

Adding the laminate provides a smooth surface for the workpiece to slide against. And the extra thickness of the hardboard forms a dust relief once the tables are added.

After gluing the hardboard and laminate in place, the next step is to drill a series of holes in the fence. The large hole in the center of the

fence provides clearance for the flush trim bit used to joint a workpiece (see photo at left).

The other holes are used to mount the router, attach the jointer tables, and secure the braces. Note: There are two things to keep in mind as you locate the mounting holes for your router. First, position the router so the on/off switch is in a convenient location near the top. And second, don't cover up the mounting holes later when you install the table supports (Figure 2).

**Assemble the Base.** Once you've drilled out all the holes, you're ready to assemble the base. The only thing that's important here is to ensure that the fence is square to the base once the braces are screwed in place.

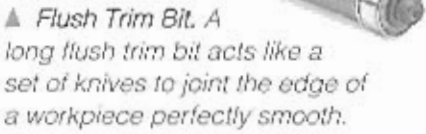

▲ **Flush Trim Bit.** A long flush trim bit acts like a set of knives to joint the edge of a workpiece perfectly smooth.

# adding the Table Supports

The next step to building the jointer is to add the table supports you see in the drawing at right.

Like a typical cast iron jointer, the infeed and outfeed tables rest on inclined "ways" that allow you to adjust the position of the tables. Well, this benchtop jointer is no different. The incline of the supports allows you to accurately align the tables and adjust the cutting depth.

There is one difference to point out. Because of the rotation of the bit, you'll be jointing from left to right, opposite of a typical jointer.

**Make a Laminated Block.** As you can see in Figure 2, the table supports are built up from a triple layer of  $\frac{3}{4}$ " plywood. To ensure that the tables and supports mate perfectly, I made both at the same time from a pair of oversized blanks, as detailed in the box below.

**Mount the Supports.** With the supports in hand, you're ready to attach them to the base. As Figure 2 shows, the table support under the outfeed table is glued permanently

2 FIGURE

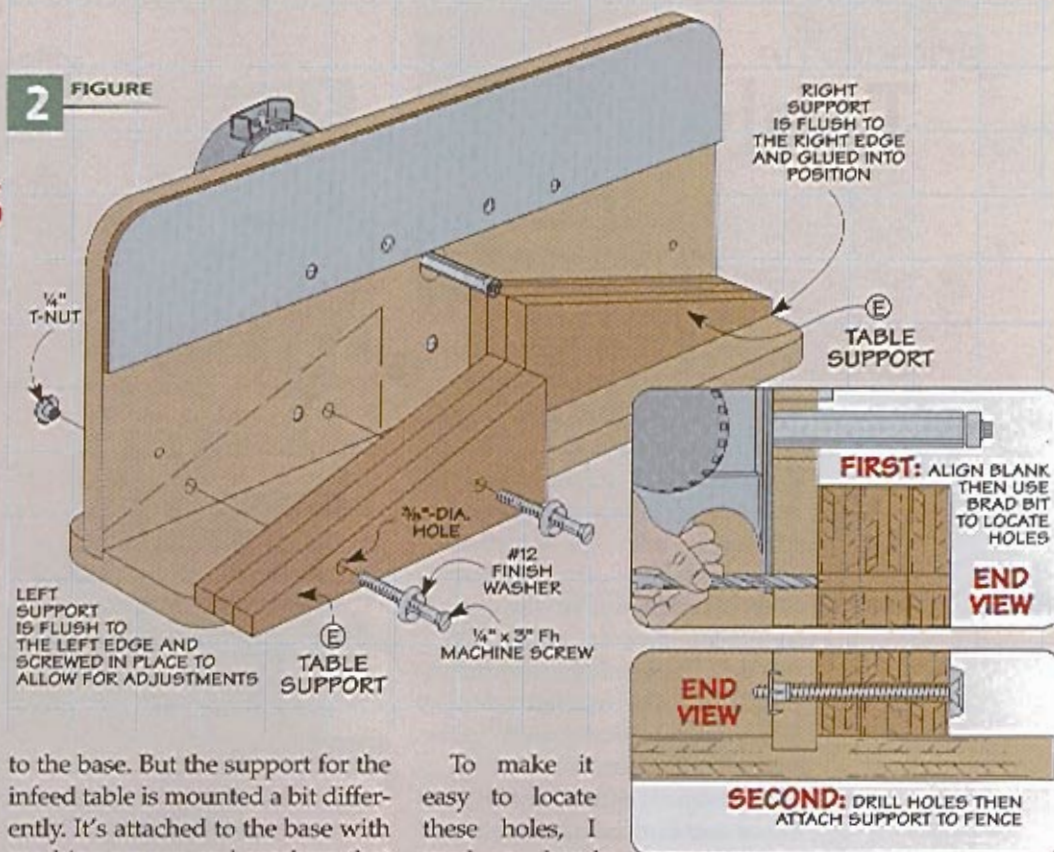

to the base. But the support for the infeed table is mounted a bit differently. It's attached to the base with machine screws and washers that pass through oversized holes in the support (Figure 2).

The oversized holes make it easy to adjust the position of the support, and as a result, the position of the infeed table. As you'll see later, this provides a little "wobble room" for aligning the infeed and outfeed tables parallel with each other.

To make it easy to locate these holes, I used a handy little trick like you see in the detail drawings above. It's nothing more than using a brad point bit to mark the hole locations through the fence.

Once you drill out the holes, you can tap a pair of T-nuts in the back side of the fence. Then just use the machine screws and finish washers to secure the table support.

## Making Laminated Blanks

Instead of making each support and table separately, I found it easier to start with oversized blanks and make them in pairs.

To make the blanks, I glued up three pieces of  $\frac{3}{4}$ " plywood that were a little wider and longer than what's shown in the drawing at right. Once the pieces are glued together, you can trim all four edges to create the final size of the blank and then add the plastic laminate, like you see at right.

The next step is to cut each blank into two parts — a perfectly mated table and support. You can learn more about this by turning to Shop Short Cuts on page 15.

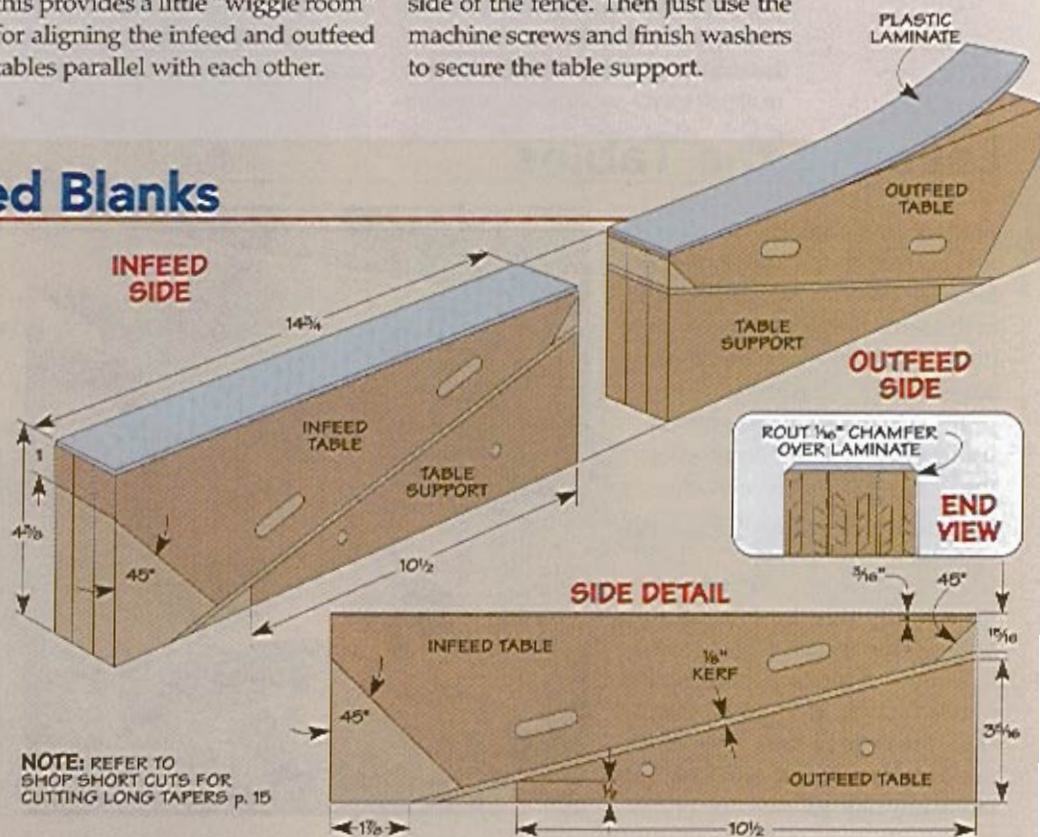

# adding the Tables

With the table supports in place, you're ready to add the heart of the jointer — the infeed and outfeed tables, like you see at right.

Since you already cut the parts for both tables earlier when you made the table supports, all that's left to do is attach the tables to the jointer. Unlike the table supports where only one is adjustable, both the infeed and outfeed tables are adjustable. Why? It simply makes the overall alignment process easier. Once you've completed the alignment, you'll lock the outfeed table in place and it won't need to be adjusted after that.

**Adjustment Slots.** To allow the infeed and outfeed tables to adjust up and down, they slide along the table supports. So you'll need to cut a couple oversized slots in each table, as shown in Figure 3.

Locating these slots is just a matter of setting the tables in place and then roughly locating them so they're level with the cutting edge of the flush trim bit, as shown in the drawing at right. Once you've

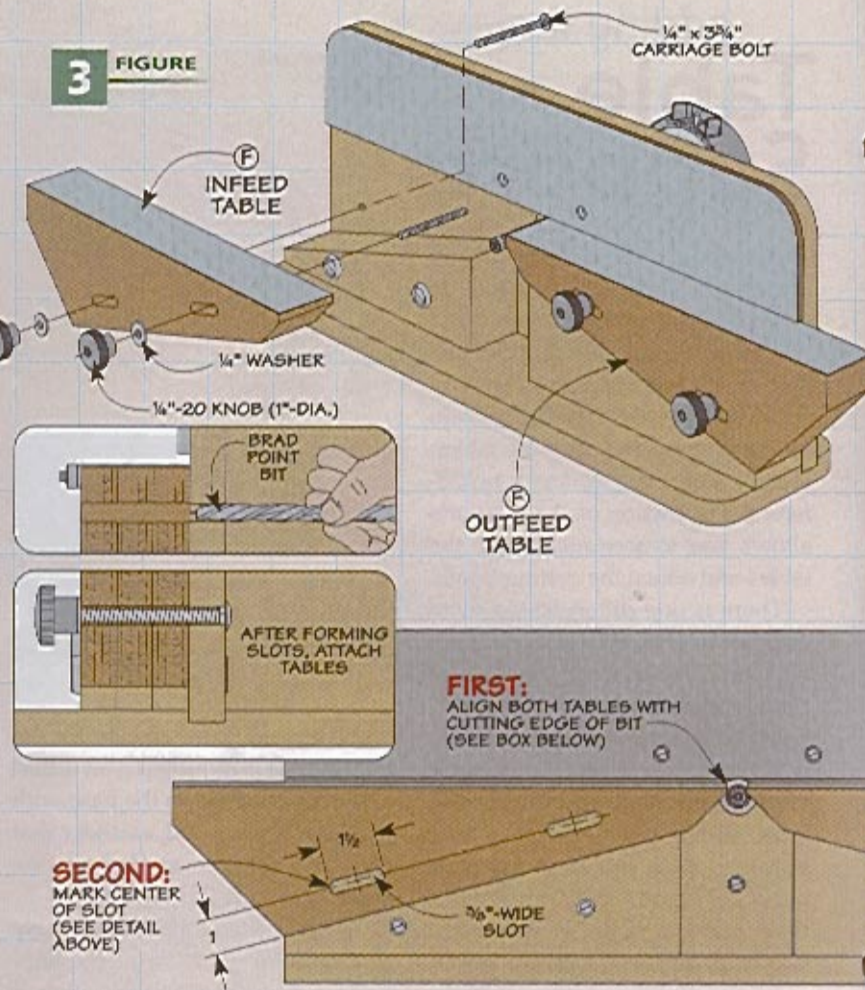

done that, simply slip a brad point bit through the holes in the back of the fence to locate the center of each slot. You can see how this

works in the detail drawing shown above. The mark you make is the center of the slot, so you can use it as a reference for completing the layout. To form the slot, drill a series of overlapping holes. A little work with a chisel is all it takes to clean up the edges of each slot.

**Aligning the Tables.** With the slots complete, you're ready to complete the installation by aligning both tables and the flush trim bit with each other. Each table is secured with a pair of carriage bolts that pass through the back of the fence, as illustrated in the detail drawing above. A pair of knobs and washers lock the table tightly against the fence.

The box at left shows a simple way to go about accurately aligning the two tables and bit using a straightedge. Once the alignment of the tables is complete, you can finish up your jointer by adding a guard for the bit and a port for dust collection.

## Leveling the Tables

For accurate results, the infeed and outfeed tables need to be perfectly parallel to each other. And at the same time, the outfeed table must be level with the cutting edge of the flush trim bit.

To align both tables, start by using a straightedge to position the outfeed table level with the flush trim bit and then lock the table in place.

Next, raise the infeed table level with the bit and then use the straightedge to see if the infeed table is parallel to the outfeed table. If it isn't, simply shim the front or back edge of the infeed table support until the two tables are aligned, as in the photo.



# mounting the Guard

Once the tables are in place, the jointer could be used. But like any power tool, the cutting edge should have a guard. As you can see in the photo at right, this shop-built guard looks and operates just like the real thing.

As the workpiece passes over the bit, the guard pivots out of the way. Once you complete the cut, the spring-loaded guard snaps back in place to safely cover the bit. An added benefit to installing the guard assembly is it makes it easy to hook up a shop vacuum to collect the dust and chips.

**Making the Guard.** I started on the guard assembly by making the guard itself. You'll find a template at the lower right to get the shape just

right. After shaping the guard from a piece of  $\frac{1}{2}$ "-thick stock, you can glue on the circular pivot post that will hold the guard above the bit.

**Add the Mounting Plate.** At this point, I set the guard aside to work on the mounting plate you see in Figure 4. Near the top edge of the plate, you'll notice a hole with a band saw kerf cut through it. This hole slips over the bearing on the flush trim bit while the kerf allows you to "pinch" the plate in place.

A large notch at the bottom of the mounting plate provides access to any mounting screws used to attach the router. The plate is attached to the table supports using trim washers and screws that pass through oversized holes.

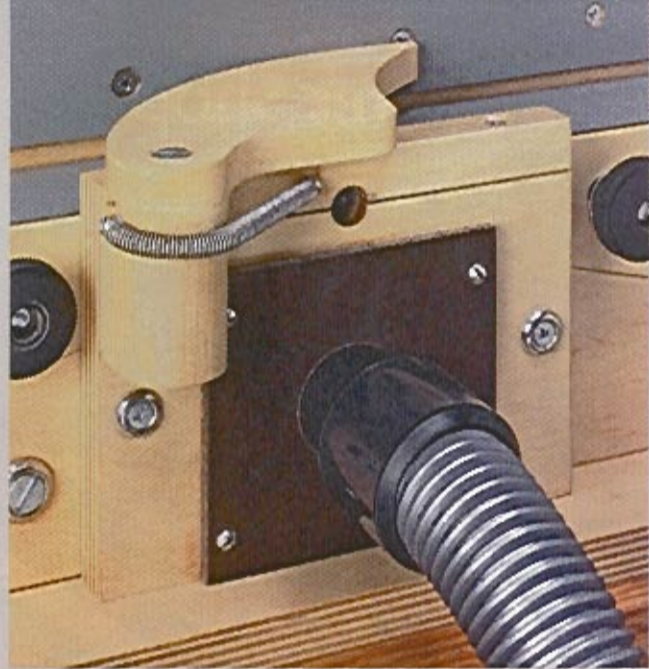

To attach the guard to the mounting plate, I added a post mount (Figure 4). It's simply glued in place. A large machine screw then passes through the guard and into the post mount. To automatically return the guard against the fence once the cut is complete, there's a spring wrapped around the pivot post.

**Add the Dust Port.** Finally, to keep dust and chips under control, I added a dust port, as illustrated in Figure 5. The port is nothing more than a piece of  $\frac{1}{4}$ " hardboard with centered hole sized to fit the end of a shop vacuum hose. Once that's in place, you're ready to begin routing perfectly square and straight edges.

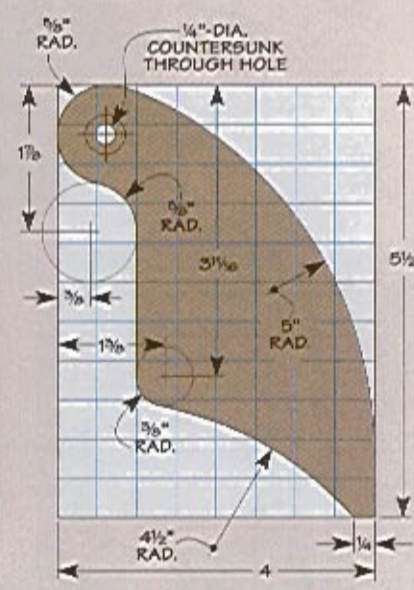
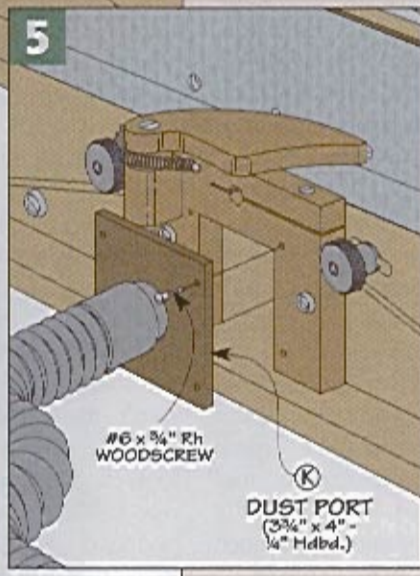
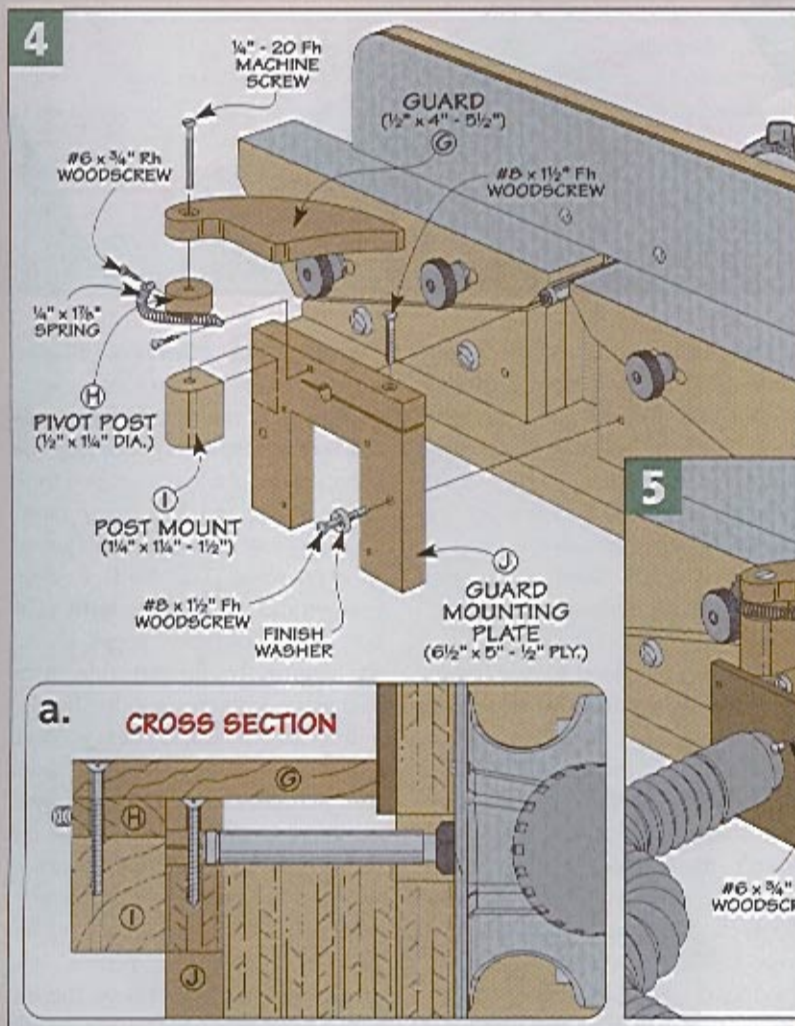

**GUARD PROFILE**

# high-tech, smooth-cutting Rasps

These lightweight rasps pack a big punch with a fast-cutting action.

Way in the back of my tool chest are a few rusty, old rasps. I admit they're not used much. It's not that they don't work. When it comes to shaping curved and round parts, like cabriole legs, nothing beats having a rasp close at hand. They cut much quicker and more aggressively than either files or sandpaper.

The problem is they work almost too well. I end up spending so much time cleaning up the furrows and gouges left by the rasp, that I avoid using it. But recently, I came across a new tool that takes a totally different approach to shaping wood.

The *Microplane* rasps, like the one shown in the photo above, remove wood just as fast as traditional rasps. But the big difference is the smoother surface they leave behind. So you'll spend a lot less time sanding after using them.

**Lightweight Tool.** At first glance, a *Microplane* rasp doesn't look like a woodworking tool. It consists of a molded plastic handle with a long blade. And when you pick one up, you'll notice how lightweight it is. It seems more suited to the kitchen than the shop.

It's tempting to think these tools aren't meant for serious woodworking. But the truth is, these tools can stand up to more than just wood. *Microplanes* can be used on plywood, MDF, rubber, plastic, even autobody filler and fiberglass.

**One Tool, Several Blades.** Besides their unique look, *Microplane* rasps work differently than other rasps. A typical rasp has a thick, steel blade with raised teeth that scratch and tear away material. On most rasps, the teeth are set in even rows. This leads to deep gouges and can clog the teeth. (The box at the bottom of pages 40 and 41 features traditional-style rasps that leave a much smoother finish.)

Instead of thick, heavy steel, *Microplane* blades are made from thin stainless steel. The blades are replaceable and "pop" out of the handle with a pencil, like you see in the photo at left. This lets you swap out one profile for another. You can choose among flat, round, and angled profiles (photos on the top of the opposite page). Each profile

**Replace the Blade.** All it takes is a pencil to pop out one blade and snap in a different profile or grade.





▲ **Multiple Profiles.** The handle can accept flat, round, or angled blades in either "coarse" or "fine."

comes in either a "fine" or "coarse" grade. For most woodworking tasks, I've found that the fine blades worked the best at removing material quickly and leaving a smooth surface.

**Slicing, Not Tearing.** The way a *Microplane* blade cuts is unique. In the right photo, you can see that the surface of the blade is covered with teeth much like a cheese grater.

The teeth are cut into the blade with a photo-etching technique that guarantees sharpness and a uniform size. These teeth act like

small, low-angle planes that slice the wood fibers cleanly, leaving a surprisingly smooth surface. Besides reducing sanding time, a big advantage of this design is that the teeth aren't as likely to clog up with chips and stop cutting.

A side benefit of the snap-in tool handle is shown in the photo at right. The plastic handle has a small thumb grip built into the end. Although it may not seem like much, the thumb grip gives you a lot more control over the tool.

**Long-Lasting Blades.** The snap-in design makes it easy to purchase an inexpensive replacement blade when one gets damaged or dull. But the low-angle slicing action of the blades means there isn't as much stress on each cutting tooth, so the blades will last a pretty long time before you need to think about replacing them.

Just how fast the blades get dull will depend on the material you're working with. Shaping plastic and rubber will dull the blades faster than only cutting wood.

**Care of Microplanes.** The best way to care for a *Microplane* is to keep the blades from bumping into other tools. Dents and dings in the



blades will shorten the life of the cutters and can lead to the blade tearing. But because the tools are made from stainless steel, they won't rust like traditional rasps.

After trying out these simple tools, you're sure to find some good ways to put them to use. *Microplanes* aren't limited to rasp-like tools. You can see a couple other applications in the box below.

And on the next page, you'll find some techniques and tips for getting the best, smoothest results when working with *Microplanes*. Turn to page 51 to find out where to get these handy tools.

▲ **Sharp Teeth.** Tiny teeth are "etched" into the stainless steel blade. The non-clogging teeth slice the wood fibers cleanly.

## Beyond Rasps: Fast-Cutting Tools

The same cutting action used in *Microplane's* rasps has been applied to a couple of other innovative tools. The first is a finer-cutting replacement blade for the popular *Surform* tools shown in the photo below.

The other unique application is shown in the photos at right. Here, a *Microplane* rotary shaper is powered by a drill press for a smooth shaping action that cuts wood faster than a drum sander.



◀ **Tool Upgrade.** You can replace the regular *Surform* blade with a faster cutting *Microplane* blade.



▶ **Power Shaper.** A *Microplane* drill press rotary shaper cuts faster than a drum sander and won't clog or burn the workpiece.



## Techniques for Using a Rasp

A rasp is one of those tools that just seems to be easy to use — and it is. In fact, they don't come with instructions. But the truth is, there are a few techniques that can make getting smoother, more consistent results with a rasp as easy as 1-2-3.

There are three basic sets of motions for using a rasp effectively. The first two motions are used to remove the tool marks and rough out the overall shape of the workpiece. The final strokes will refine

and smooth the shape before finishing up with sandpaper.

There's one more thing to note. While these techniques are shown using a *Microplane*, they work just as well with a traditional rasp.

**Cutting Direction.** Although rasps will cut in any direction to the grain, it works best to take cuts at an angle. This is especially true of *Microplanes*. The teeth are more likely to clog when taking cuts with the grain. The reason is that cutting

with the grain results in long splinters instead of small chips.

**Cross Strokes.** The first step in shaping a workpiece, like the cabriole leg shown here, is to remove the saw marks left by the band saw and establish the overall shape. For this, I use cross strokes.

I'll hold the rasp with both hands, then take an angled stroke across the workpiece with firm pressure. This stroke is similar to a sawing motion, as you see in the



▲ **Cross Strokes.** Work the rasp at an angle across the grain to rough out the overall shape. The overlapping strokes will remove wood quickly.

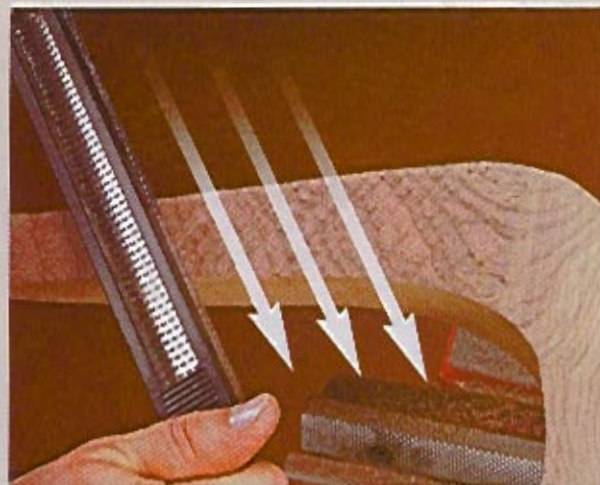

▲ **The Other Way.** Use cross strokes going in the opposite direction to further shape the workpiece and remove the marks from the previous step.

## Old-World Tool: Auriou Rasps

The trouble with most hardware store rasps is that they only come in one style — aggressive. And I can easily end up going past the layout lines when cleaning up the scratches left by these rasps.

That's where the *Auriou* (Are-you) rasps you see here come in. They've

been made in France since 1856, but only recently have become more available in the United States. It may be tempting to think that a rasp is a rasp, but there are a few features that make these rasps stand out from rest of the pack.

**Hand-Cut Teeth.** The first things that I noticed were the teeth. They're set in a random pattern. The random spacing means the rasp leaves a smoother surface than if the teeth are set in straight rows like a typical rasp (photo at right). The *Auriou* rasps accomplish this by "stitching" or hammering the teeth by hand.

**Grades.** Cutting the teeth by hand makes it easier

▲ **Several Grades.** *Auriou* rasps range from large, coarse-cutting tools to small and smooth-cutting.



left photo on the opposite page. Repeat this motion in long, overlapping strokes along the length of the workpiece. At this point, you'll notice the saw marks have been replaced with a series of diagonal scratches in the surface.

**Reverse Direction.** The next stroke is similar to the first. The goal here is to further refine the shape of the workpiece and remove the scratches left by the first stroke. There's just one differ-

ence. The strokes in this step should angle the opposite direction, as you can see in the right photo on the opposite page.

You can repeat these two strokes until the workpiece is close to its final shape. The left photo below shows a slight variation of the cross stroke that may come in handy.

Reverse the direction of cut by pulling the rasp toward you from the opposite side. You may find this works well if you experience a

lot of chipout when pushing the rasp in the other direction.

**Drawing the Rasp.** The final stroke removes the scratches left by the previous steps and leaves a pretty smooth surface. To do this, hold the rasp at a slight angle and draw it along the length of the piece like you would skew a block plane (right photo below). You'll want to work with a light touch here to smooth the surface, not remove a lot of wood. 



▲ **Pull Stroke.** If you get tearout from the previous motions, try reversing the direction of the rasp. Flip the tool end for end and pull it toward you to cut.

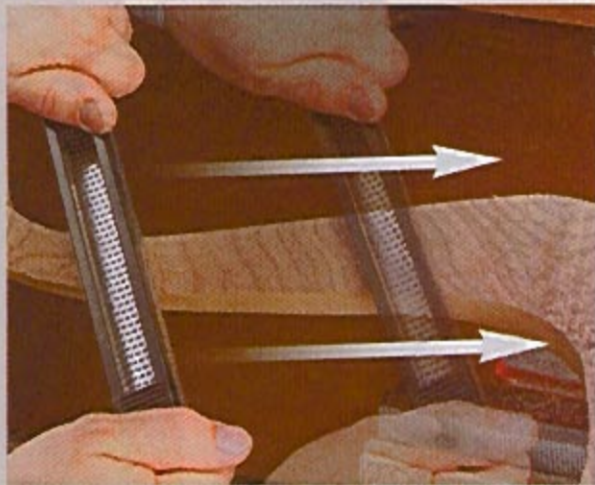

▲ **Drawing the Rasp.** Sliding the rasp along the workpiece removes scratches left by the previous steps and smooths out the shape.

to vary the size of the teeth to make rasps of different grades or "grains." (Smaller teeth cut slower and smoother.) *Auriou* rasps are available in 15 grades.

I found that the finest six grades are the most useful for woodworkers. The coarsest grades are used in stone carving. One of the benefits of so many grades is that you can move from a fast-cutting rasp to a finer, smoother cutting grade and still remove material faster than with files or sandpaper.

**Shape.** A final feature of these rasps that I liked is their shape. Like many rasps, the *Auriou* rasps come with one rounded and one flat side. But the big difference is at the end of the tool. All of the rasps

come to point. This point makes it easy for me to get into tight corners when shaping and smoothing details. There are even teeth cut in the edge right up to the point, as in the photo at right.

**Cost.** As you might expect, all these features come at a cost. The rasps range in price from about \$50-80 apiece. To find out where you can order these rasps, take a look at page 51.

Are they worth it? Well, if you do a lot of shaping curved parts and carved detail, then getting a few of these rasps will be just the thing. But occasional users may find they may need only one. Either way, you'll be reaching for them often and getting great results.

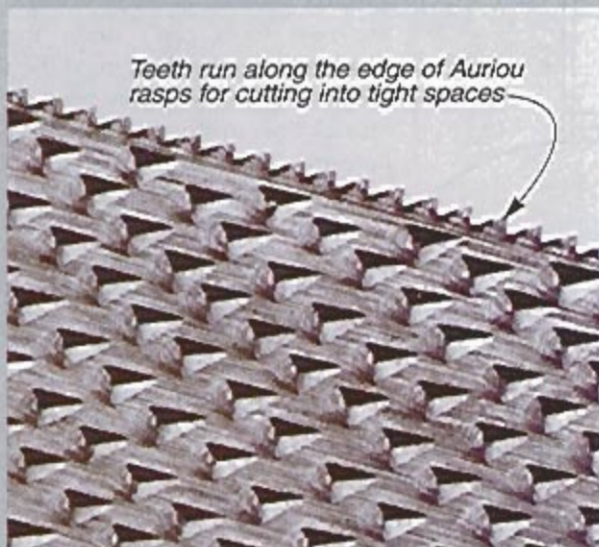

▲ **Random Teeth.** The hand-cut teeth on *Auriou* rasps are spaced randomly so that they leave a smooth surface and cut aggressively.

SETTING UP  
Shopdealing with  
**Lumber Storage**

A little planning now will save a lot of time and frustration later.

Let's face it. Lumber storage is not very glamorous. Oh, we're all proud to show off a new table saw or new shop cabinets, but no one gets real excited about the wood piled over in the corner or along the walls of our shop.

But proper lumber storage is just as important as placement of your tools. If your lumber ends up damp, warped, twisted, or cracked because of poor storage, the best tools can't undo the damage, no matter how good they are. So, if you feel you need to rethink how to store your lumber, here are a few tips to consider.

**Easy Access.** The best place in your shop to store lumber is near the entry door. It can be quite hazardous to try to snake an 8'-long board through the door, over

your workbench, and around the band saw. So, look near the door for storage space.

Another good idea is to have your chop saw or another cutoff tool nearby your storage area. If you only need 2' of an 8' board, why tote that 8' board to your saw on the other side of the shop, cut it, and then have to take the remaining 6' back to the storage area? Having a cutoff tool near your storage space eliminates a lot of extra work — believe me.

**Vertical.** If your shop ceiling is high enough and you have no wall cabinets in the way, you can stack the boards vertically, like most home centers do. While this saves a lot of floor space, you need to make sure the boards stay

upright. Vibrations caused by such ordinary things as opening and closing the door can send the boards crashing to the floor or onto whatever tool or vehicle is nearby. One remedy I found is to screw eyebolts into studs about 5' off the floor and attach bungee cords between them to hold the tops of the boards in place, as you can see in the drawing on the far right of the opposite page.

This drawing also shows a clamp about midway up the stack of lumber. Stacking lumber vertically can cause the boards to bow in the middle. By clamping the

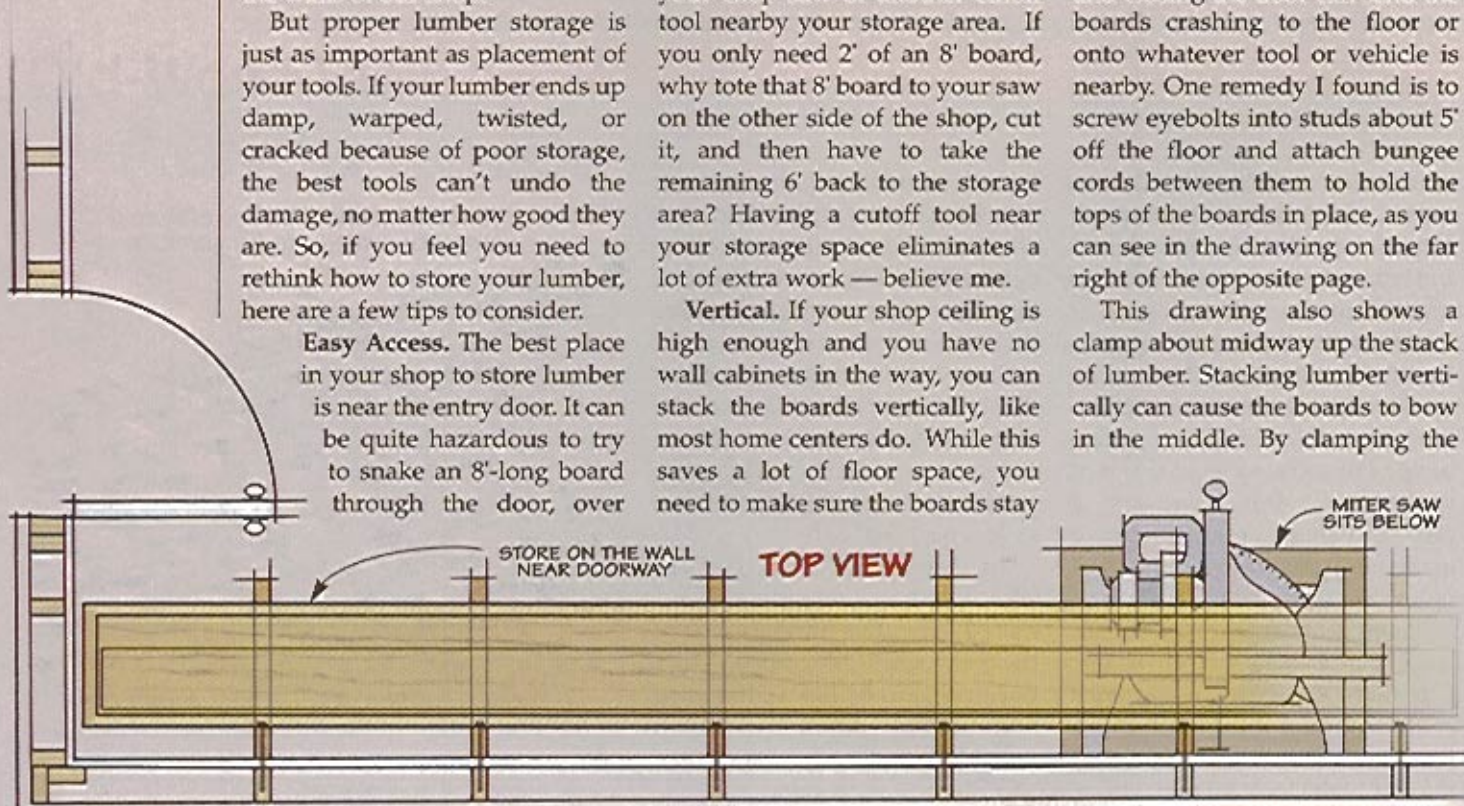

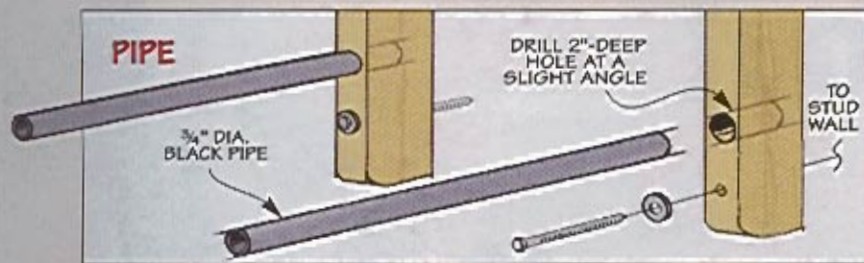
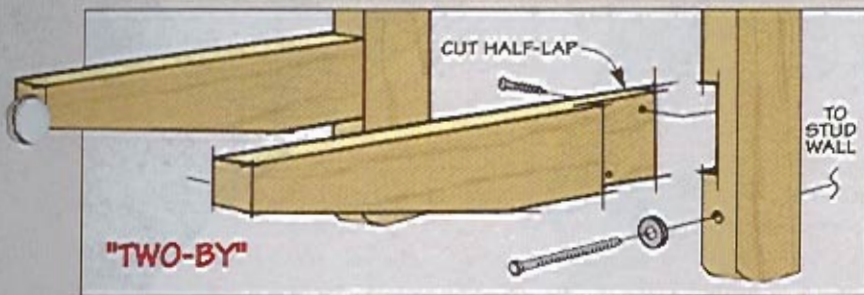

boards together, their combined thickness helps the stack stay straight and keeps the individual boards from sagging. And just to be on the safe side, I rotate the vertical stacks every so often to reverse any slight bowing that still may occur.

**Horizontal.** Storing lumber horizontally, or flat, is a good option if you have enough wall space. Commercial storage systems are available, as well as lots of plans to make one yourself — just think of shelving systems without the shelves.

The two drawings above show you a couple of ideas on

how to build your own horizontal storage system using either 2x4s or pipes for the supports. Make sure to secure the storage system adequately to the wall studs. It doesn't take much lumber to make a heavy load.

A good reason to avoid stacking a lot of lumber on the storage system is that the board you really want will almost always be on or near the bottom of a stack. The higher the stack, the more boards you'll have to move to get to that board.

This brings up another point. Don't stack your lumber across the entire width of your shelf brackets. When you have to move

boards around, the extra space on the brackets gives you a place to put the boards you don't want to get to the board you do want.

**Off the Floor.** No matter which storage method you choose, an important thing to remember is to get your lumber off the floor. In many garages and basements, moisture can seep up through the floor and be absorbed into your wood, especially through the end grain. If you stack your lumber vertically, try to get the boards off the floor by using some sort of platform, such as the one at the bottom of the drawing on the right. If you store your lumber horizontally on shelf brackets, you've pretty much eliminated a lot of moisture concerns.

**Cutoffs.** If you're a packrat like me, you hate throwing away wood, even small pieces. You just never know when you might need that 2'-long strip of red oak that tapers from 1 5/16" to 3/8". Stacking it vertically doesn't work very well because it can get lost behind the longer boards, and storing it horizontally just clutters your brackets. The box at left illustrates my solution to storing cutoffs.

So, you see, protecting your lumber investment requires a little more thought than just piling it all in a corner. You need to consider the amount of space you have and the layout of your shop. Then, when you bring in the expensive walnut to build that bedside table, you'll have the right spot to keep it safe and sound.

## Storing Cutoffs

One answer to storing cutoffs is to place them in trash cans or 5-gallon buckets. The pieces will stand vertically, they'll be in a single location, and they will be off the floor. For longer pieces, I prefer a heavy-duty 33-gallon plastic trash can. The metal ones can be noisy when pieces are thrown in and are all too easy to dent. For shorter pieces, a smaller trash can or empty bucket works great.

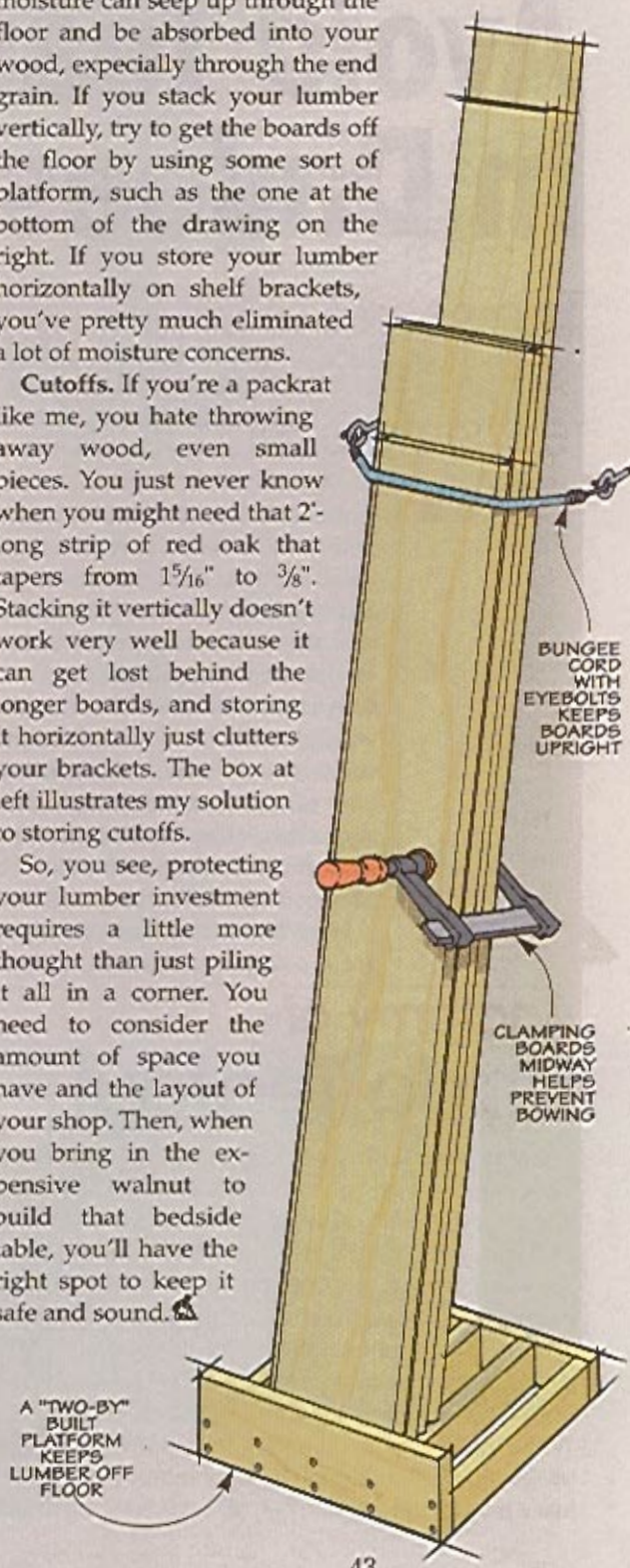

## MASTERING THE Table Saw

# 7 sure-fire ways to Avoid Tearout in Dadoes

The secret to clean, crisp dadoes is using a few simple techniques.

- Cutting dadoes on the table saw with a dado blade is something I do all the time. But I try to never be routine about it. Because I've found that there's a nasty problem that can pop up. You can set up, carefully make the cut, and then flip the workpiece only to find that the shoulders on both the face and the end of the cut are rough and ragged with tearout. This can be a problem on any type of wood, but plywood can really give you fits.

**Why Tearout in Dadoes?** There are a couple reasons why tearout

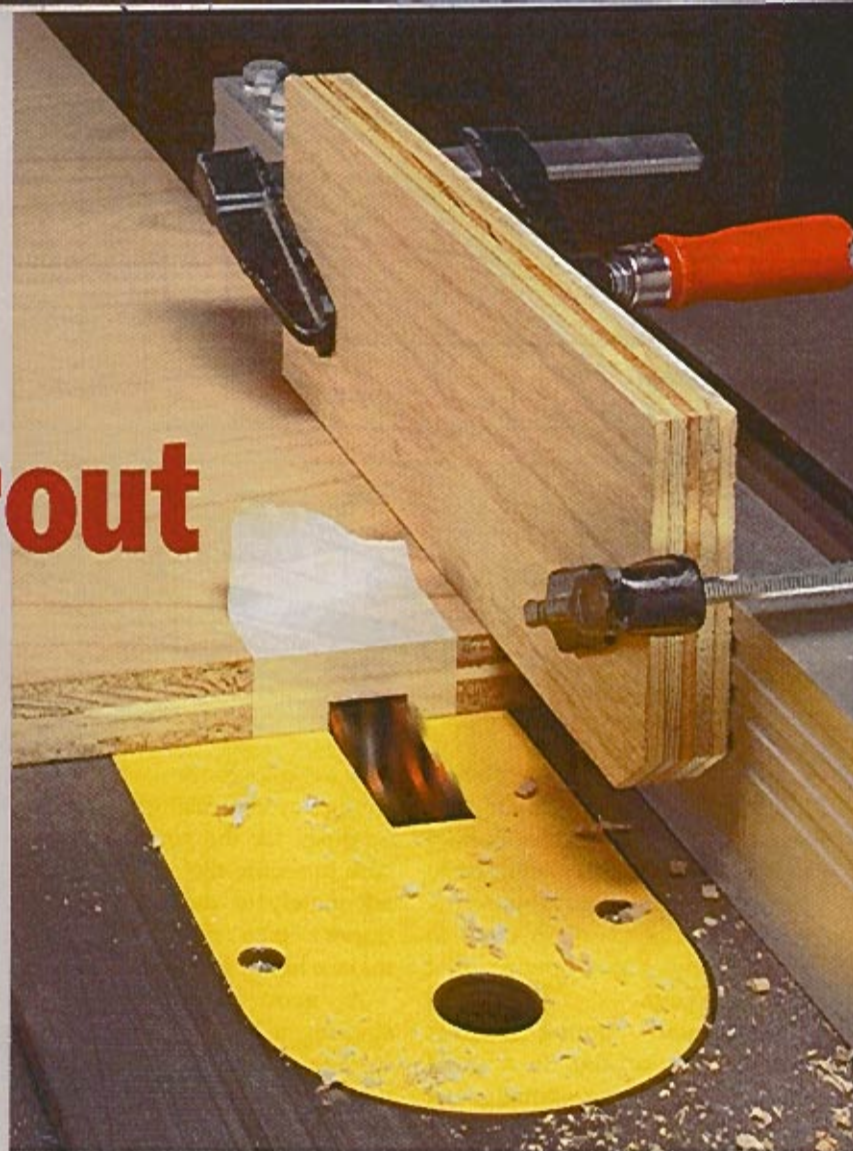

occurs on dado cuts. They both have to do with the dado blade and how it cuts. As the drawing below shows, a cut with a dado blade isn't a through cut. The blade is essentially trapped in the workpiece, surrounded by wood on all sides. This makes it harder for the blade

to clear chips and dust from the cut. To compensate for this, a dado blade usually has fewer teeth and wider gullets on the outer scoring blades. But fewer teeth on the blades can mean a rougher cut.

And then consider the cutting angle of a dado blade. For a dado, the cutting angle will be shallow and the blade ends up pushing forward into the wood instead of cutting down on it. This hammering action is more likely to blow out the wood fibers instead of severing them cleanly.

The good news is that no matter what kind of dado blade you use, there are some quick and easy precautions you can take to avoid tearout.

## Anatomy of Dado Tearout

Chances are, if you've ever cut a dado on the table saw, you've been a victim of "dado" tearout. It shows up on the surface of the workpiece along the shoulders of the dado cut (Side View at right) and on the edge of the workpiece where the blade exits the cut (End View at right). The symptoms are pretty obvious—chips of wood that are roughly pulled loose from the surface instead of being cleanly cut. When the joint is going to be exposed on the project, this can end up being a lot more than just a minor aggravation.

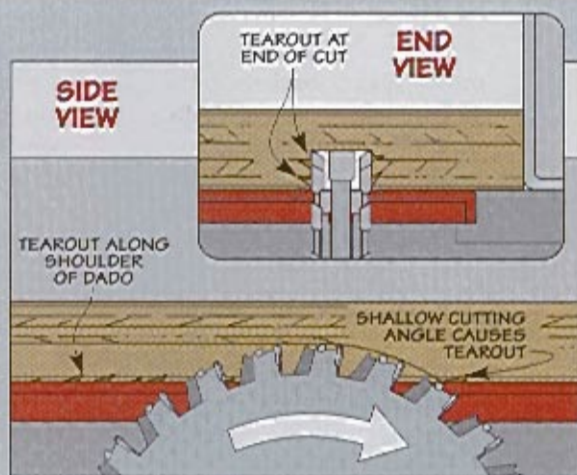

## THE SETUP

When I'm getting ready to cut dados, the first item on my checklist is proper setup of the table saw. You'll find the better-quality cut is well worth the little bit of extra effort.

**1 Zero-Clearance Insert.** One of the easiest ways I can think of to ensure a clean dado cut is to use a zero-clearance throat insert as shown in the photo at left. What a zero-

clearance insert does is support the workpiece right up to the edge of the cut. It essentially acts as a back-up to the workpiece. This allows the blade to cleanly slice the wood fibers at the shoulders of the dado instead of raggedly tearing them.

**2 Hold-down.** When possible, I always clamp a hold-down to the rip fence of the saw for a dado

cut. First off, it keeps the workpiece snug to the surface of the table saw so that the zero-clearance insert can do its job. And next, it helps control any vibration or chatter of the workpiece that may cause a rough cut.

The simplest hold-down can be a scrap of wood that rubs the workpiece, as in the photo at left. But a featherboard could also do the job.

**ShopNotes**  
GO ONLINE  
EXTRAS

To view a video on using these table saw techniques, go to: [www.ShopNotes.com](http://www.ShopNotes.com)

## THE WORKPIECE

The focus of the effort here is on ending up with a perfect workpiece. So it makes good sense to spend some time getting the workpiece ready for the cut. And there are simple ways to do this.

**3 Overwidth Workpiece.** When the ends of your dados are going to be exposed, you want them to be crisp and clean. Tearout as the blade exits the cut ruins this effect. But the fix here is simple.

I'll start with a workpiece that's slightly oversized, as shown in the first drawing at right. Then I can cut the dado without too much worry about tearout at the edges. After the cut is completed, the extra width can be trimmed off, leaving crisp, sharp edges.

**4 Scoring.** One of the oldest tricks in the book is to score your cut with a sharp knife before you make it (left drawing above). This is a good way to prevent tearout on

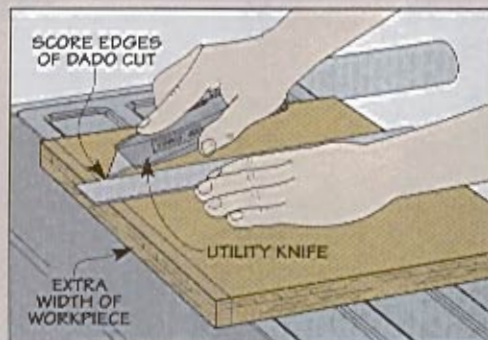

▲ **Two Remedies.** An oversized workpiece can be trimmed to remove tearout. Scoring the cut at the edges keeps it from occurring.



▲ **Tape Reinforcement.** Masking tape pressed firmly onto the workpiece will reinforce the wood for a chip-free cut.

both the face and the edge of the workpiece. What you're doing is pre-cutting the fibers on the surface so that the dado blade can't tear them when you make the cut.

It only takes shallow cuts to do the job, but they need to be accurate. If they're inside the lines of the cut, they won't do any good.

**5 Masking Tape.** I always keep a roll of masking tape at hand when I have the dado blade on the

saw. As shown in the right drawing above, a piece of tape pressed firmly over the line of the cut acts like a back-up "veneer" to reinforce the wood fibers. This is surprisingly effective at keeping both the shoulders and the ends of the cut sharp and clean.

Just be careful when removing the remaining tape. Peel toward the cut to avoid pulling any of the wood fibers away with the tape.

## MAKING THE CUT

When it's time to make the cut, there are a couple of really effective strategies you can use to get good results.

**6 A Shallow Pass.** I sometimes use an initial, shallow scoring pass to establish a cleanly cut line along the shoulders. To do this, raise the blade only  $\frac{1}{32}$ " to  $\frac{1}{16}$ " above the saw table, just high enough to score the shoulders without chipping them. Then apply good downward pressure on the workpiece during the cut. After this initial pass, you can raise the blade to the full height of the dado and complete the cut.

**7 Provide Backup.** A great way to avoid a rough exit to the cut is to back up the workpiece with a scrap (right drawing). Since the blade is cutting directly from the workpiece into the scrap piece, there's no chance of tearout.

To do its job, the back-up piece needs to be in firm contact with the workpiece. So use a scrap with a straight, square edge and, when possible, clamp the back-up piece to the workpiece. This allows you to concentrate on the cut and not on holding the scrap in place. ▲

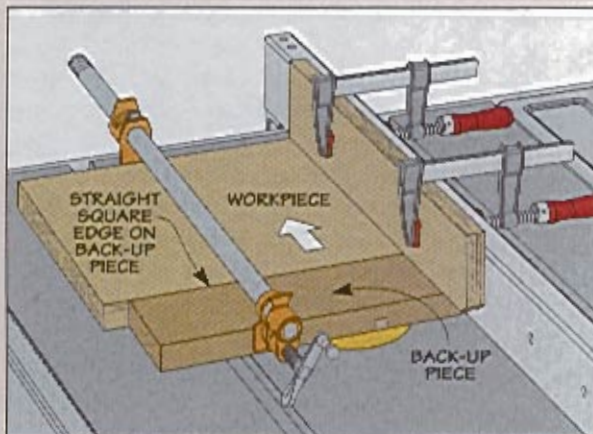

▲ **Back Up the Cut.** A back-up piece clamped to the workpiece is a very simple way to prevent tearout at the edge as the blade exits the cut.

NEW  
Department!

GREAT  
Gear



▲ **Paste Wax.** Applying a coat of paste wax prevents rust and corrosion on table tops and other large surfaces. Simply rub it on and let it dry for a few minutes. Then buff it out with a clean, soft cloth.

## top-notch techniques for **Preventing Rust**

■ I hate rusty tools. And I've spent countless hours over the years cleaning the rust off of tools in my shop. It seems like I just get them clean only to find rust on them again — sometimes overnight.

So I finally came to realize that I could make better use of my time by preventing rust from forming in the first place. That way I won't have to spend so much time removing it from my tools.

There are many ways to prevent rust. But the way you deal with it will depend on the type of tool.

Lubricants work great for protecting small parts and moving parts. But they're not a good solution for large tool surfaces. The oil and grease will attract dust and can get on the wood used in your projects. Fortunately, there are a number of alternatives.

### SEAL THE TOOL

Moisture and oxygen are needed to produce rust. So it makes sense that sealing the tool so that water and oxygen can't get to the surface will prevent rust and corrosion.



▲ **Toolwipes.** These Bullfrog wipes let you coat your tools to keep moisture and air away from the metal. They're a quick way to keep hand tools rust-free.

**Paste Wax.** One of the oldest and easiest solutions is to use paste wax (see inset page 46). It's inexpensive and a good way to seal the tops of large tools. Just apply a thin coat, like you do when you wax your car (but don't use car wax). Then let the wax dry and buff it out. The wax forms a barrier to moisture and oxygen.

**Aerosol Sprays.** Rust sealers can be applied in different ways. I like aerosol sprays because they're easy to apply, dry quickly, and get into all the little nooks and crannies.

**Boeshield T-9** is an aerosol sealer that's made up of various solvents, lubricants, and paraffin wax. Just spraying on a light film and wiping it off protects and lubricates your tools. Once dry, there's no oily film. So it won't interfere with the finish on your project workpiece.

If you want to protect a tool during a period of non-use (like over the summer), just spray it on and let it set. Then when you're ready to use the tool again, all you need to do is buff it out.

Another product I like is **TopCote**. It also comes in an aerosol spray. Just spray it on and let it dry for a few seconds. Then rub it out with a clean cloth. You'll need to reapply any of these products occasionally to ensure continued protection.



**Toolwipes.** When it comes to small hand tools, **Bullfrog Toolwipes** (see photo bottom page 46) are one of the easiest products to use. You use them just like baby wipes. It only takes a few seconds to apply a coating that keeps the moisture out. I use them to wipe down my tools when I finish using them.

### REMOVE THE MOISTURE

If your tools are stored in a tool box, tool chest, or other enclosed area, a desiccant like silica gel or the **Tool Buddy Moisture Eliminator** can help keep them rust-free. These work the same as those small packets you find packed in with electronics, cameras, and other items when you receive them.

The bag, like you see in the photo above, is filled with small chemical crystals that absorb moisture from the air. But it must be

### ▲ Desiccants.

Crystals in the package pull moisture out of the air, preventing rust formation. The blue dot on the front of the package turns pink when it's time to replace the bag.

replaced when the crystals can't absorb any more moisture.

A new product that provides longer-term protection in enclosed spaces is vapor inhibitors. They're simple to use and won't harm your tools. To learn more about these, check out the box below.

Using techniques like these and a few minutes of time, you can keep your tools looking like new. You'll find sources for products to help you listed on page 51. 🐸

## Long-Term Protection: Rust Inhibitors

A relatively new way to protect your tools from rust involves a special substance placed in an enclosed space, like a tool box or tool chest. This substance gives off protective vapors that spread through the air. Once these vapors contact the metal surface, they form a thin invisible layer that prevents oxidation (interaction of air and moisture with metal). The coating inhibits the formation of rust and corrosion for up to a year. It won't change the look or feel of the tool. And it doesn't leave any residue that might interfere with finishing.

You can get these inhibitors in a cup or strip for use in small tool boxes or drawers. The **Bullfrog Shield** (photo at right) is made to be used in larger tool storage containers and tool boxes. They're also non-toxic and environmentally safe.

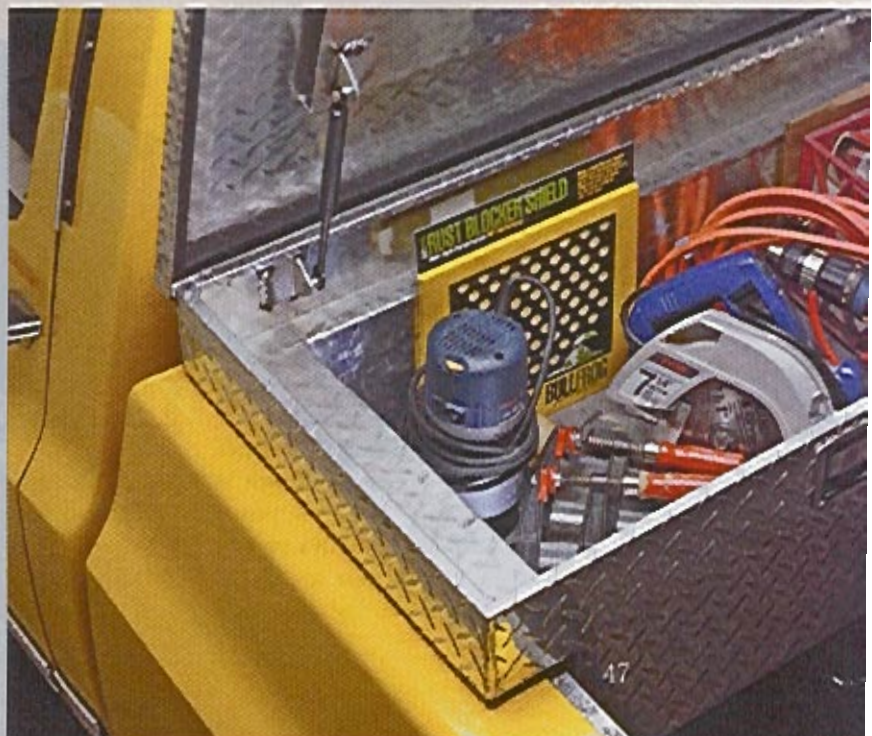



Space-Saving

# Slat-Wall Systems

- Once confined to retail stores selling the latest fashions, slat-wall systems are moving out of the malls and into home shops and garages. And it's easy to see why. With all the accessories that are available, you can make short work of expanding and rearranging your storage needs. Best of all, these systems don't take up much space and are quick to install.

**Choose Your Material.** Most of the slat-wall systems you'll see in retail stores are MDF. It's pretty inexpensive and comes in a variety of finishes, as you can see in the margin photo on the opposite



Brackets



Bins

page. There are a few downsides to MDF however. First of all, it's pretty heavy and can be challenging to install on your own. Along with that, typically MDF slat-wall comes

in large (4'x8') sheets. So you may end up buying more than you need.

The final disadvantage is probably the biggest. MDF doesn't hold up well in high-moisture environ-





▲ **Cleats.** PVC slat-wall panels can be screwed directly into wall studs (photo at left) or hung on cleats.

MDF and waterproof. This means you can install them all the way to your garage floor and wipe them clean when they get dirty.

**Easy Installation.** The individual PVC panels come between 15" and 24" widths and in 4' and 8' lengths. Installation is a quick one-person operation. Although having a little help will make things a lot easier and quicker.

I found that the hardest part was getting the first (bottom) panel level and screwed down. But once that was installed, the rest was a

snap — literally. Since the panels interlock (see left photo), all you have to do is set the second row in place and screw them at the top.

No special tools are needed for installation. The easiest method is to simply screw the panels into wall studs. I drilled pilot holes in the grooves to hide the screw heads. You can also use cleats like in the photo at left, spacing them every 2 square feet of slat wall.

**Accessories.** Like I mentioned before, what makes slat-wall systems so versatile are the accessories that make organizing your garage a breeze. A wide variety of hooks, baskets, shelves, and bins can handle just about any storage need you have, from screws to wheelbarrows. And if you're really serious about organizing, cabinets and even a desk are available for slat-wall systems.

**Where to Buy.** For flexibility, slat-wall systems are hard to beat. And they're becoming more widely available. You can find a few sources on page 51. And for a do-it-yourself slat-wall solution, take a look at the box below. 📦



▲ **Appearance.** Slat walls come in several finishes, including wood grain.

▲ **Interlocking Panels.** The interlocking feature makes installing multiple panels easier.

ments like garages (or basements). Because it's porous, MDF readily absorbs water. When it does, the sheets will swell and warp. That's why I turn to a different material altogether — PVC.

The PVC slat-wall systems you see in the photos here overcome all these problems. You'll find that the panels are significantly lighter than

## In the Groove: Making Your Own Slat Wall

Slat-wall systems can add some flexible organization to just about any workspace. But you don't have to limit yourself to commercial versions. Several router bit manufacturers have bits that allow you to rout all the slat wall you need from plywood and MDF. This lets you customize your slat walls to fit your exact needs.

**Special Bit.** As you can see in the photo on the right, all you need are a router, a slat-wall cutter bit, and a straight edge. The bit I used cuts a  $\frac{5}{16}$ " x  $1\frac{1}{16}$ " slot with a  $\frac{3}{8}$ " groove. You can find a few sources for the bits listed on page 51.

**Setup.** Before routing the slats, there are a few things to do for the best results. First, to make sure that the panels will line up with each

other, I took extra care making sure the panel blanks were perfectly square. It's also a good idea to make a few test cuts to get the bit depth set for the accessories.

Once the bit is set, you can lay out the grooves on the panels and start routing. In fact, I found that the actual cutting of the slots was the easiest part.



▲ **Slat-Wall Cutter.** Router bits such as this one help you make your own slat-wall panels.

# Q & A

questions from  
Our Readers

## solutions for End Drilling Dowels

I am working on a project that requires drilling centered holes into the ends of dowels of varying lengths. What's the best way to do this?

Lowell Zetterman  
Lincoln, Nebraska

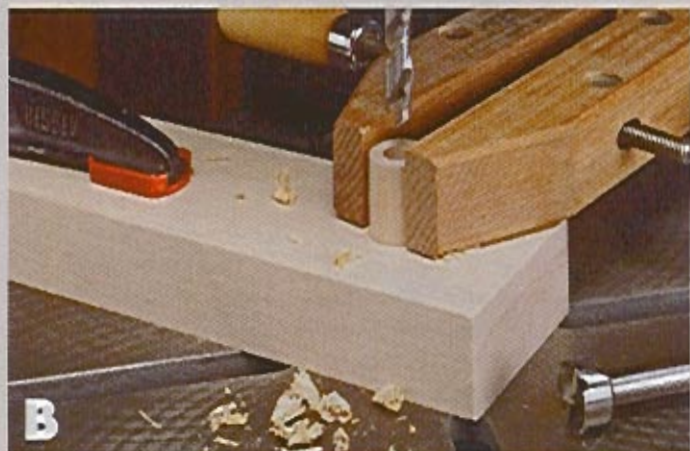
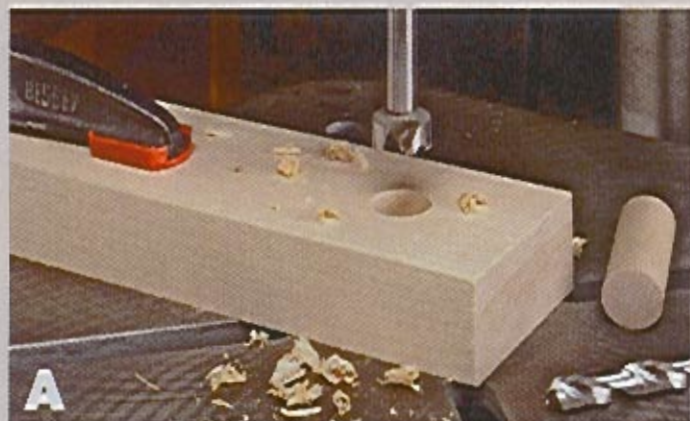

Drilling a hole is usually a simple task. But drilling a centered hole into the end of a dowel presents a different set of problems. It's easy to drill off center or angle the hole.

There are a couple of tricks I use when I need to center a hole in the end of a dowel. If I'm drilling a short section of dowel, I start by clamping a piece of scrap to the table of my drill press. Then I use a Forstner bit to drill a hole in the scrap piece that

matches the diameter of the dowel, as shown in photo A above.

After installing the right diameter brad point drill bit, slipping the dowel into the counterbore automatically centers it under the tip of the drill bit. To make sure the dowel doesn't spin while drilling, clamp a handscrew around it, like you see in photo B above. This holds it firmly in place. Then it's just a matter of drilling the hole in the dowel.

**Long Dowels.** Occasionally, I need to drill a hole in the end of a long dowel. The problem is moving the drill press table out of the way, yet still having a way of holding a long dowel securely.

To solve this problem, I built the jig shown below. What makes this work is the beveled block attached to the fence on the jig. It forms a "pocket" that "traps" the dowel against the fence while you drill.

### Drilling into Long Dowels

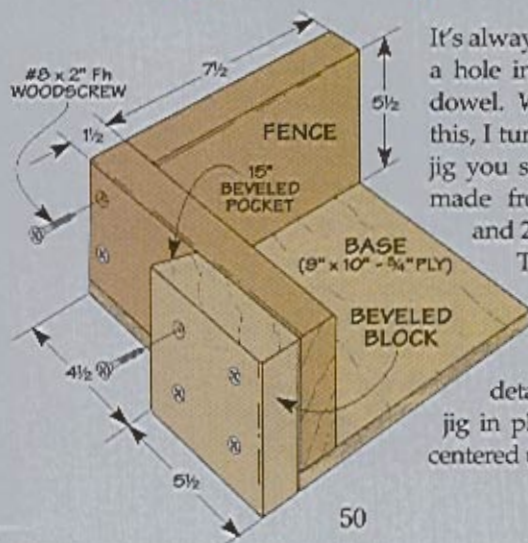

It's always a challenge to drill a hole in the end of a long dowel. When I need to do this, I turn to the handy little jig you see at left. The jig is made from scrap plywood and 2x6 stock.

To use the jig, adjust the drill press table so the bit is aligned like you see in the detail. Then clamp the jig in place so the dowel is centered under the bit.

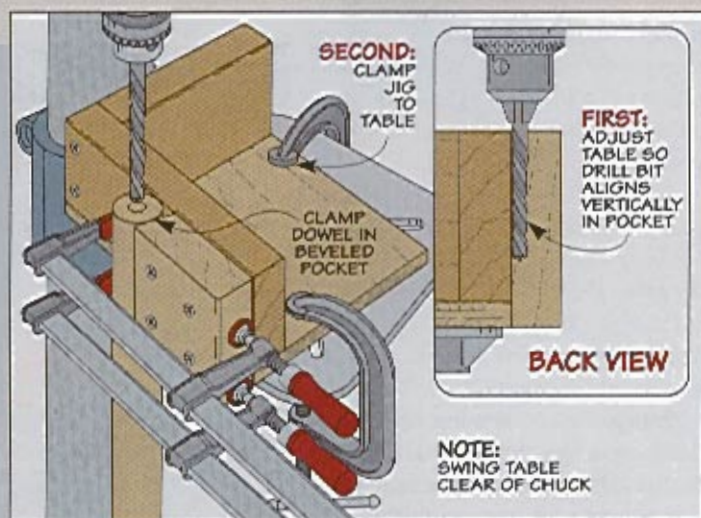

# Sources

## MULTI-PROFILE BITS

Look through just about any wood-working catalog and you'll see a version of the multi-profile bit featured in the article on page 8. The bit we used (99-PK1) is made by Freud and costs around \$80. Amana makes a similar bit (54200).

Freud also has a "miniature" version of the large multi-profile bit called the 99-PKJ. You might find this "mini" bit to be a better choice for making trim and molding for your smaller projects.

## DOWELMAX

If you've always shied away from using dowels in a project, the Dowelmax precision engineered joining system featured on page 12 might just bring dowel joinery back into your shop.

The system is available from OMS Tool Company Ltd. (see margin for contact information). Priced at around \$230, it's not an inexpensive doweling jig. But the jig and accessories are topnotch and you'll find yourself using it often.

## HEIRLOOM TOOL CABINET

All the hardware needed to build the heirloom tool cabinet (page 16) is available from Rockler (as well as other sources). To start with, you'll need a couple pairs of 2" hinges

(25668) for the doors. The drawers require a couple of different sizes of wood knobs (88783 and 36509). Then you'll need some door catches and leg levelers (30546 and 24315). Finally, to mount the drawers, I used 14" Accuride full-extension drawer slides (89674).

## ROUTER JOINTER

If you already have a router, all you'll need for the router jointer featured on page 32 is a long flush trim bit and a handful of hardware. The flush trim bit we used is made by Amana (47126). Most wood-working catalogs will carry a similar bit and there are other sources listed in the margin.

The knobs might be the only hardware item you'll have trouble finding locally. We used 1" knobs from Rockler (34095).

## HIGH-TECH RASPS

The Microplane rasp with the replaceable inserts (3200 series) shown in the article on page 38 is available from a couple sources listed in the margin. These same sources carry the rotary shaper (30040-30043, 30045) and Surforn replacement blades (30021, 30004).

You might have trouble locating the Auriou rasps. The margin lists two sources for the three rasps fea-

tured in the article (AU-6-150-15, AU-6-175-13, AU-4-250-9).

## DEALING WITH RUST

Rust is such a big problem that you'll find all sorts of products for dealing with it. A few of them were featured in the article on page 46.

The Woodsmith Store carries Boeshield T-9, Bullfrog Emitter Strips and TopCote. PMS Products Inc. also carries Boeshield. For the Tool Buddy Moisture Eliminator, you can call Rockler. And to get any of the Bullfrog products, check the margin at right for contact information.

## SLAT-WALL SYSTEMS

There are a number of makers of slat-wall systems. The Woodsmith Store and Rockler carry the plastic StoreWALL brand shown on page 48 along with accessories for hanging just about anything.

The slat-wall panels made from MDF can be difficult to locate. It generally comes in large sheets, so shipping can be expensive. Your best bet is to check in the phone book under "Store Fixtures" or "Display Fixtures & Material."

Finally, you can make your own slat-wall. The part number for the Freud T-slot bit you'll need is 52-222 and the Amana version is 45660. Sources are listed in the margin. 

## MAIL ORDER SOURCES

Similar project supplies may be ordered from the following companies:

**Woodsmith Store**  
800-835-5084

woodsmithstore.com  
Amana Flush Trim Bit, Bullfrog Emitter Strips, Drawer Slides, Fasteners, Knobs, Microplane Products, Multi-Profile & T-Slot Bits, Self-Centering Drill Bits, StoreWALL, Table Saw Inserts, T-Nuts, TopCote

**Rockler**  
800-279-4441  
www.rockler.com

Drawer Slides, Flush Trim Bit, Microplane Products, Multi-Profile Bit, StoreWALL, T-Slot Bit, Tool Buddy Moisture Eliminator

**Reid Tool**  
800-253-0421  
www.reidtool.com

Knobs  
Freud  
800-334-4107  
www.freudtools.com  
Flush Trim Bit, Multi-Profile Bit, T-Slot Bit

McFeely's  
800-443-7937  
www.mcfeelys.com

Fasteners, Trim Washers  
OMS Tool Company Ltd.  
877-986-9400  
www.dowelmax.com

Dowelmax  
Amana  
800-445-0077

www.amanatool.com  
Flush Trim Bit, Multi-Profile Bit, T-Slot Bit

McMaster-Carr  
630-833-0300  
www.mcmaster.com

Knobs

**Bullfrog**  
800-426-7832  
www.bullfrog.com

Emitter Cup, Shield & Strips, Toolcipes

**PMS Products Inc.**  
800-962-1732  
www.boeshield.com

Boeshield T-9

**The Best Things**  
800-884-1373

www.thebestthings.com

Aurou Rasps

Tools for Working Wood  
800-426-4613

toolsforworkingwood.com

Aurou Rasps

## ShopNotes Binders

### Keep your issues organized!

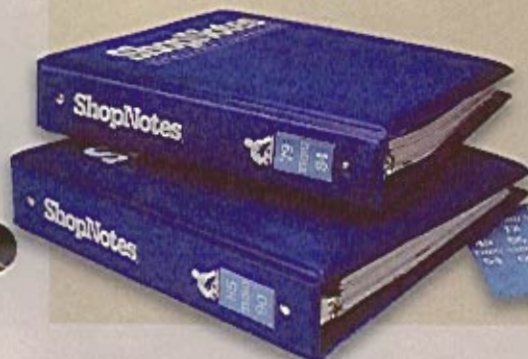

As you build your ShopNotes library, here's a way to keep your issues organized. Each binder features durable vinyl covers and easy-to-read perforated number tags. Snap rings with a quick-open lever make it easy to insert and remove issues. And there's an extra pocket inside for storing notes. Each binder holds a full year (6 issues) of the new expanded ShopNotes.

To order these binders, call 1-800-347-5105.

### ShopNotes Binder

○ 701950-SN80 (Holds 6 issues).....\$12.95

## Scenes from the Shop

Need a jointer but don't have the room? Then you might want to give this shop-built, benchtop model a try. With just a router and a flush trim bit, you'll be jointing straight, square edges on stock up to 1 3/4" thick. With adjustable tables, a built-in guard, and a dust collection port, this jointer has all the features of a full-size model. Detailed plans start on page 32.

