

ROUTER UPGRADE: All New Circle Jig

ShopNotes®

Vol. 14 Issue 83

www.ShopNotes.com

GET ORGANIZED!

- **EASY-TO-BUILD MODULAR WORKSTATION**
- **COMPLETE TABLE SAW ACCESSORY RACK**

PLUS:
SIMPLE STEPS FOR MAKING MOLDING

A Publication of August Home Publishing

\$4.95US

016 85J2983
AUG-85J2983

\$4.95



059308

SHOPNOTES #83

Contents



Table Saw
Accessory Rack page 28

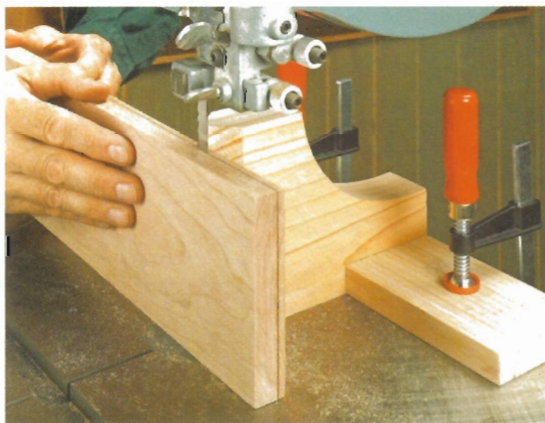

Resawing Secrets page 30



Router Circle Jig page 32

Features

storage solutions

Modular Workstation 16

Make the most out of your shop space with this three-part storage center. Whether you build one, two, or all three pieces, you're sure to have your tools and supplies close at hand.

fine tools

Marking Knife 24

Get a better grip on your layouts with this shop-made handle for your marking knife.

weekend workshop

Table Saw Accessory Rack 28

Keep all of your table saw blades, push sticks, and other accessories within easy reach with this wall rack.

best-built jigs & fixtures

Router Circle Jig 32

Get more from your router. This easy-to-build jig uses an ordinary lazy Susan to accurately rout circular recesses and holes.

Departments

Readers' Tips 4

router workshop

Cove Bits 8

Take a closer look at these essential bits and find out how to get top-notch results.

materials & hardware

Cam Clamps 10

Reduce set-up time on your shop jigs and fixtures with quick-release cam clamps.

jigs & accessories

Shop Vacuum Upgrades 12

Make your shop vacuum more versatile with a few low-cost accessories.

Shop Short Cuts 14

Shop-tested tips and techniques to solve your woodworking problems.

hands-on technique

Band Saw Resawing 30

Cutting perfect thin boards from thick stock is quick and easy. Learn the secrets.

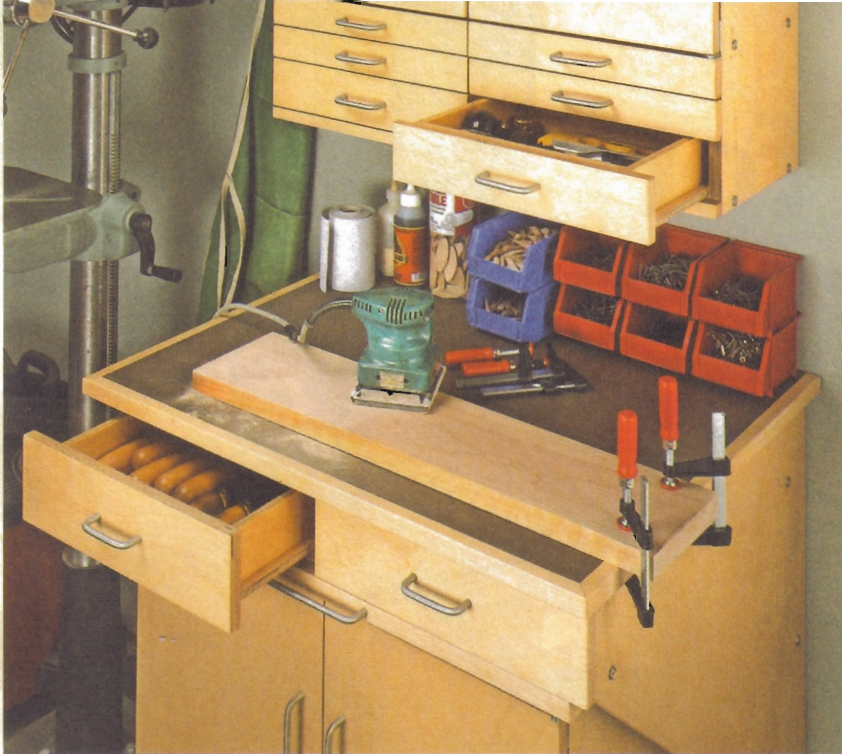

Modular Workstation

page 16

Cutoffs

Take a good tool and make it better. That's really the key to many of the projects in *ShopNotes*. And often, this involves taking a good bit of time to build a jig or an accessory to make a power tool work harder, more accurately, or more safely.

But sometimes it's nice to be able to go into the shop and complete a project in an afternoon. That's part of the reason I enjoyed the marking knife project that begins on page 24 so much. We started with a simple, Japanese-style marking knife. The razor-sharp edge allows you to strike a clean, precise layout line. But the delicate blade can be a bit difficult to hold onto. So what's the solution? We designed a custom handle — one made out of scrap wood and some copper bushings — that looks good and feels great in your hand.

This transformation from a good tool to a great one is hard to describe. But I noticed that once the handle was added, everyone who picked the marking knife up had a hard time putting it back down again.

Another project that'll make a handy addition to your shop is the all-new router circle jig shown on page 32. What makes this jig unique is that it uses a lazy Susan in the design. So you just "spin" your way to a cleanly routed hole or circle. But seeing is believing. So be sure to check out the online video we put together showing the jig in action.

Terry

in the shop
Choosing a Hacksaw _____ **38**

New frames and blades make for smoother cuts and better results.

setting up shop
Getting The Light Right _____ **40**

Everything you do in the shop starts with good lighting. Here's what you need to know to get your shop out of the shadows.

mastering the table saw
Classic Cove Molding _____ **42**

With a little time at the table saw, you can top off your project with some great-looking cove molding. We'll show you how.

great gear
Snap-In Table Saw Splitters _____ **46**

Now, there's no excuse not to use one. These three splitter options add a new level of safety to your saw and can be removed in seconds.

ultimate garage
Shop Mats _____ **48**

Work longer and feel better. Here's how to choose an anti-fatigue mat to make working in your shop more comfortable than ever.

Q&A _____ **50**

Sources _____ **51**



This symbol lets you know there's more information available online at www.ShopNotes.com

Tips for Your Shop

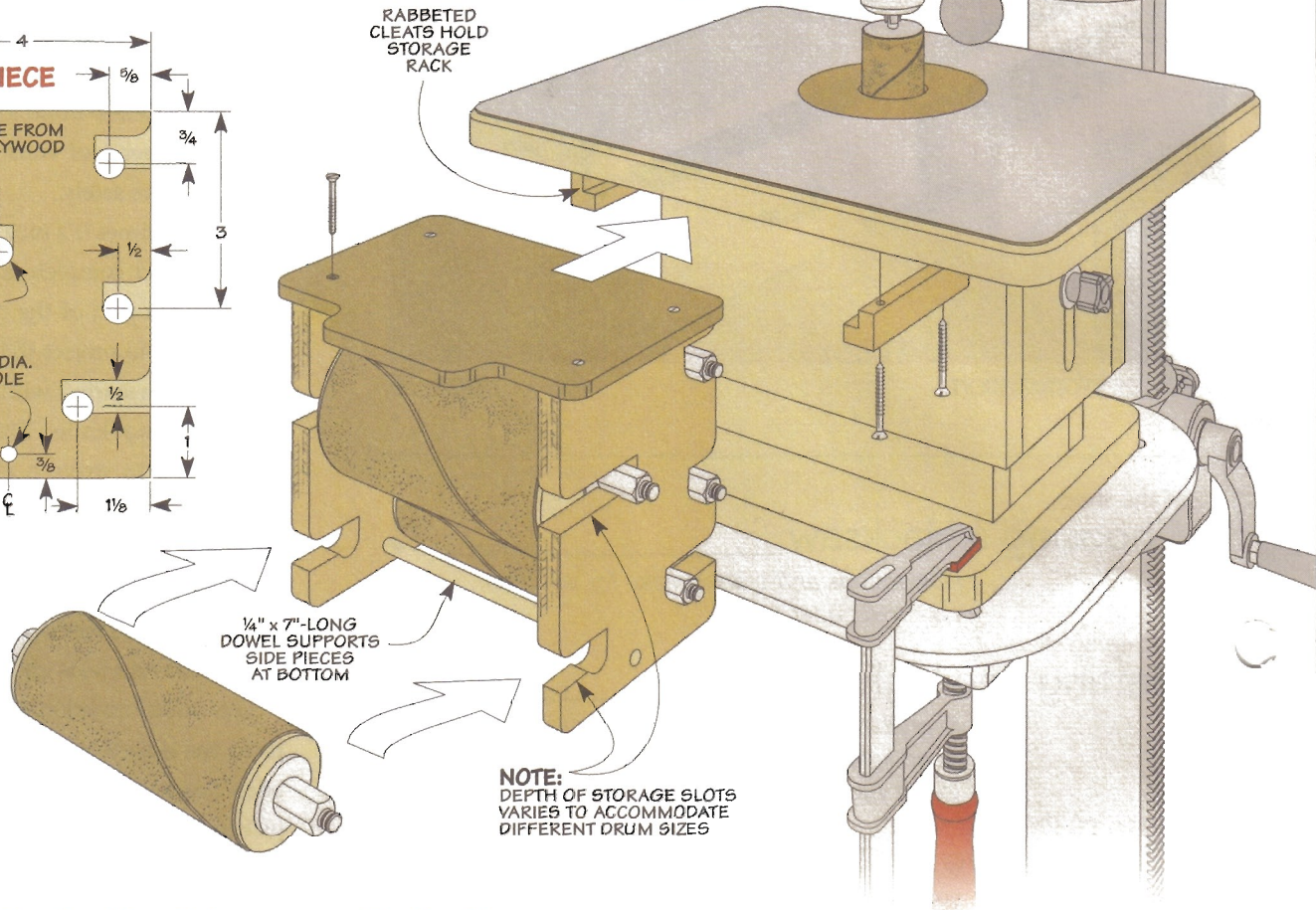
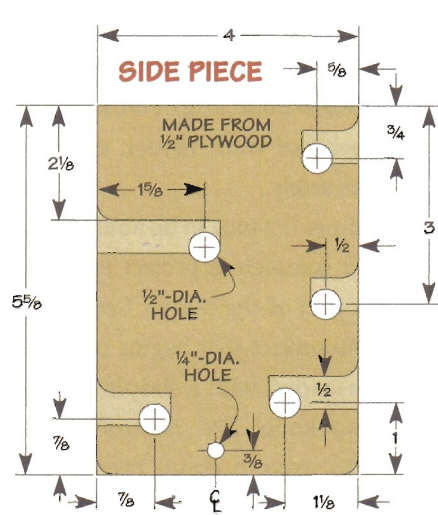

NOTE:
DEPTH OF STORAGE SLOTS
VARIES TO ACCOMMODATE
DIFFERENT DRUM SIZES

Free Tips ON THE WEB

Get more wood-
working tips free.

Visit us on the Web at
ShopNotes.com

Sign up to receive a
free shop tip by
email every week.

Spindle Storage Solution

I really liked the spindle sander project from Issue No. 81. But after building it, I needed a place to store the sanding spindles so they would be within easy reach.

So I put together this on-board storage rack to help keep the spindles organized. That way, I always know right where to find them.

The storage unit is easy to use. Each size sanding spindle has its own slot that holds it firmly in place. And when you need to change drums, you can quickly slide the entire storage rack out, select the spindle you need to use, and then slip the unit back under the sanding table again.

The rack consists of two 1/2" plywood side pieces connected at the top by a wide piece of 1/4" hardboard. A small front tab on the top piece acts as a pull so you can slide

the rack out to get at spindles stored on the other side. A 1/4" dowel across the bottom gives the lower part of the rack support.

Slots are cut out in the side pieces to hold the drums. To make sure the slots line up exactly, I carpet taped the side pieces together and then used the band saw to cut the slots on both pieces at the same time.

Two 3/4"-square rabbeted cleats attached beneath the sander table hold the rack. These cleats capture the wide top piece and allow the storage unit to slide in and out.

*Don Barrios
Baker, Louisiana*

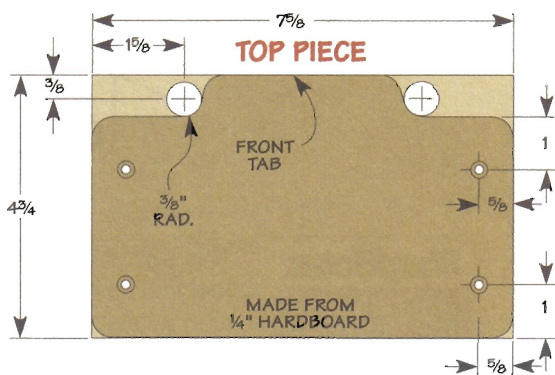

Dowel Storage

I use a lot of dowels for projects in my shop. But I had a problem storing the leftover pieces once I used part of a dowel. The shorter pieces were always hard to find and never seem to get used. To help solve this problem, I built the dowel storage box you see illustrated at right.

This storage box lets me easily store a wide range of dowel lengths. That way, I can find even the smallest pieces quickly.

The storage box consists of five compartments. Four of the compartments have false bottoms so each compartment is six inches shorter than the one next to it. This stair-step arrangement allows me to store all lengths of pieces. And a shallow tray in front lets me store the pieces that are too short to fit in any of the other bins.

New dowels go in the deepest bin. Then, as they're cut off, they're moved to the appropriate bin. Now I can easily find and make use of all the dowels I have on hand.

*Len Urban
Rancho Mirage, California*

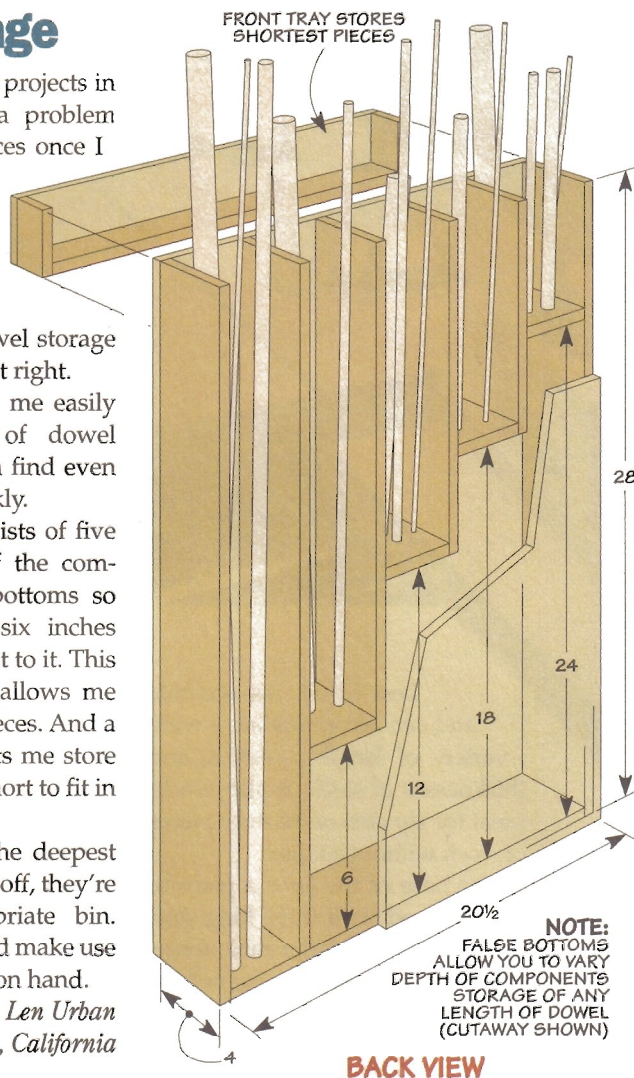

Submit Your Tips

If you have an original shop tip, we would like to hear from you and consider publishing your tip in one or more of our publications. Just write down your tip and mail it to: *ShopNotes*, Tips for Your Shop, 2200 Grand Avenue, Des Moines, Iowa 50312. Please include your name, address, and daytime phone number (in case we have any questions). If you would like, FAX it to us at 515-282-6741 or send us an email message at: shop-notes@shopnotes.com. We will pay up to \$200 if we publish your tip.

The Winner!

Congratulations to Fiske Miles of Kansas City, Missouri. His tip for making a taper jig was selected as winner of the Porter-Cable router just like the one shown at the right. The adjustable taper jig is simple and inexpensive to build, and it cuts perfect tapers every time.

To find out how you could win a Porter-Cable router, check out the information above. Your tip just might be a winner.



PUBLISHER Donald B. Peschke

EDITOR Terry J. Strohmán

SENIOR EDITORS Bryan Nelson, Vincent Ancona

ASSOCIATE EDITORS Phil Huber, Ted Raife

ASSISTANT EDITORS Ron Johnson, Mitch Holmes

EXECUTIVE ART DIRECTOR Todd Lambirth

ART DIRECTOR Cary Christensen

SENIOR GRAPHIC DESIGNER Jamie Downing

SENIOR ILLUSTRATOR Roger Reiland

ILLUSTRATORS David Kallemyn, Peter J. Larson

GRAPHIC INTERN Becky Hansen

CREATIVE DIRECTOR Ted Kralicek

SENIOR PROJECT DESIGNERS Ken Munkel,

Kent Welsh, Chris Fitch

PROJECT DESIGNERS/BUILDERS Mike Donovan,
John Doyle

SHOP CRAFTSMEN Steve Curtis, Steve Johnson

SR. PHOTOGRAPHERS Crayola England, Dennis Kennedy

ASSOCIATE STYLE DIRECTOR Rebecca Cunningham

ELECTRONIC IMAGE SPECIALIST Allan Ruhnke

VIDEOGRAPHERS Craig Ruegsegger, Mark Hayes

ShopNotes® (ISSN 1062-0696) is published bimonthly (Jan., March, May, July, Sept., Nov.) by August Home Publishing, 2200 Grand Ave., Des Moines, IA 50312. *ShopNotes*® is a registered trademark of August Home Publishing. ©Copyright 2005 by August Home Publishing. All rights reserved. Subscriptions: Single copy: \$4.95. One year subscription (6 issues): \$27.95. Canada/International add \$10 per year, U.S. funds. Canadian Subscriptions: Canada Post Agreement Number 40038201. Send change of address information and blocks of undeliverable copies to P.O. Box 881, Station Main, Markham, ON L3P 8M6. Canada BN 84697 5473 RT. Periodicals Postage Paid at Des Moines, IA and at additional mailing offices. Postmaster: Send change of address to *ShopNotes*, P.O. Box 37103, Boone, IA 50037-2103.

www.ShopNotes.com

ONLINE SUBSCRIBER SERVICES

- **ACCESS** your account
- **CHECK** on a subscription payment
- **TELL US** if you've missed an issue
- **CHANGE** your mailing or e-mail address
- **RENEW** your subscription
- **PAY** your bill

Click on "Subscriber Services" in the list on the left side of our home page. Menus and forms will take you through any of the

HOW TO REACH US:

FOR SUBSCRIPTIONS, ADDRESS CHANGES OR QUESTIONS, WRITE OR CALL.

Customer Service
2200 Grand Ave., Des Moines, IA 50312
800-333-5854 8 a.m. to 5 p.m. CT

OR SEND AN E-MAIL TO:
orders@shopnotes.com

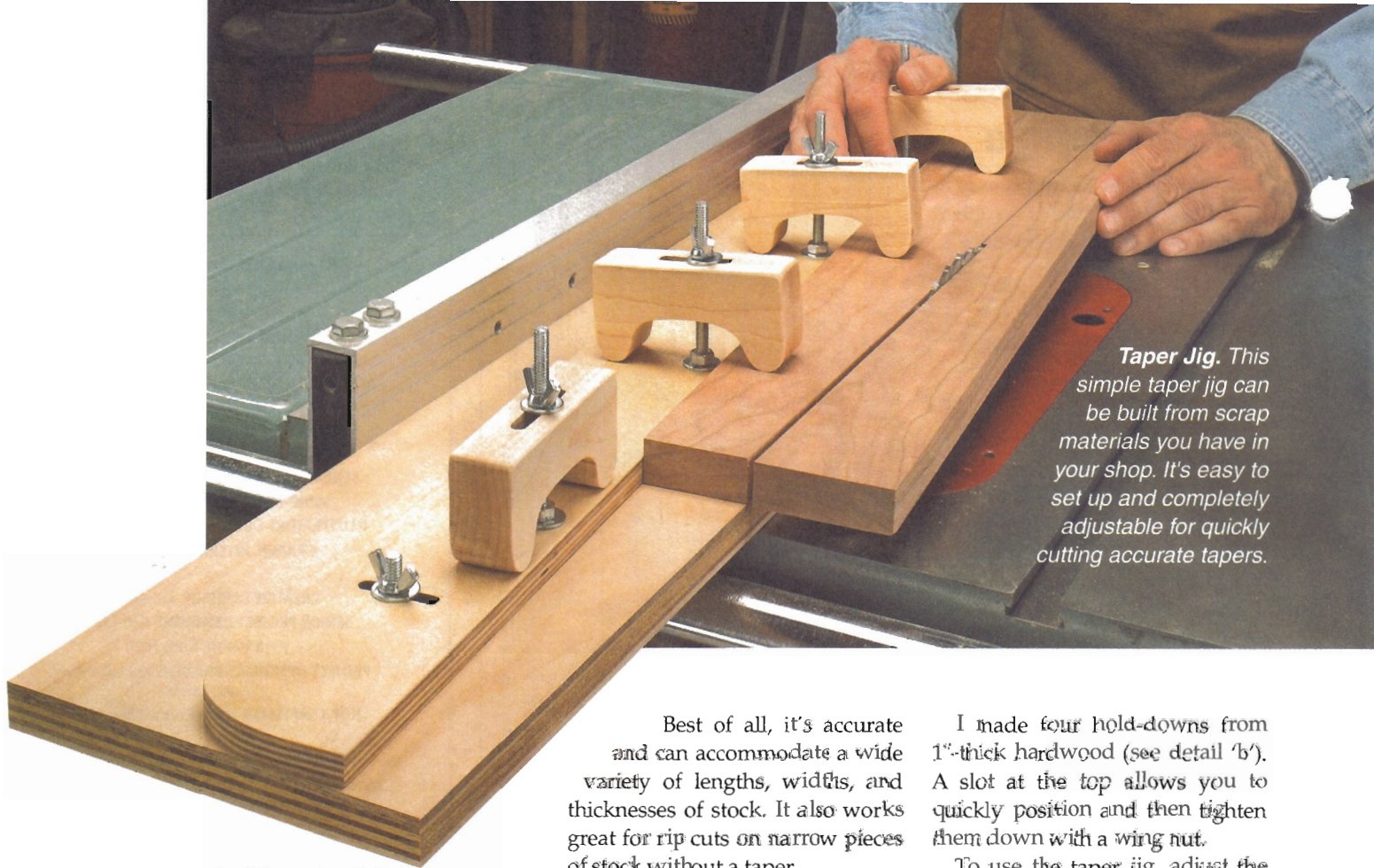

Taper Jig. This simple taper jig can be built from scrap materials you have in your shop. It's easy to set up and completely adjustable for quickly cutting accurate tapers.

Adjustable Taper Jig

I recently needed to cut some tapers for a project and didn't want to invest in a manufactured taper jig. So I built the simple jig you see in the photo above.

It doesn't take much material to build the jig. You probably already have just about everything you'll need lying around your shop.

Best of all, it's accurate and can accommodate a wide variety of lengths, widths, and thicknesses of stock. It also works great for rip cuts on narrow pieces of stock without a taper.

The base of the jig is a piece of $\frac{3}{4}$ " plywood with three long slots used to attach an adjustable fence. Each slot is recessed on the bottom so the head of a carriage bolt sits out of the way (see detail 'a').

An adjustable $\frac{1}{2}$ " plywood fence sits on top of the base. It has slots cut to match the slots in the base for adjusting the angle of the taper. Four holes in the fence accept $\frac{1}{4}$ " carriage bolts for the hold-downs.

I made four hold-downs from 1"-thick hardwood (see detail 'b'). A slot at the top allows you to quickly position and then tighten them down with a wing nut.

To use the taper jig, adjust the fence to the desired taper and lock it in place. Then swing the hold-downs over the workpiece and tighten the wing nuts in place.

Finally, set the rip fence of the table saw so the blade lines up with the edge of the jig. Then simply push the sled along the fence. That's all it takes to cut perfect tapers every time.

*Fiske Miles
Kansas City, Missouri*

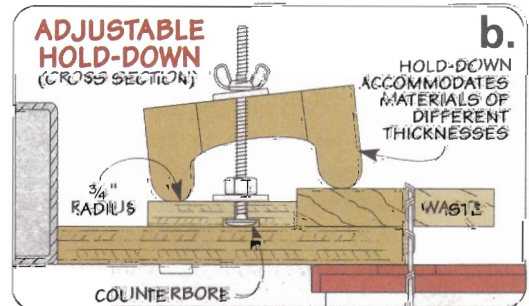
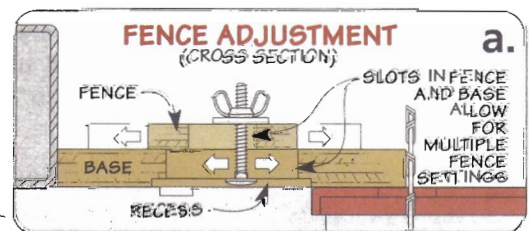
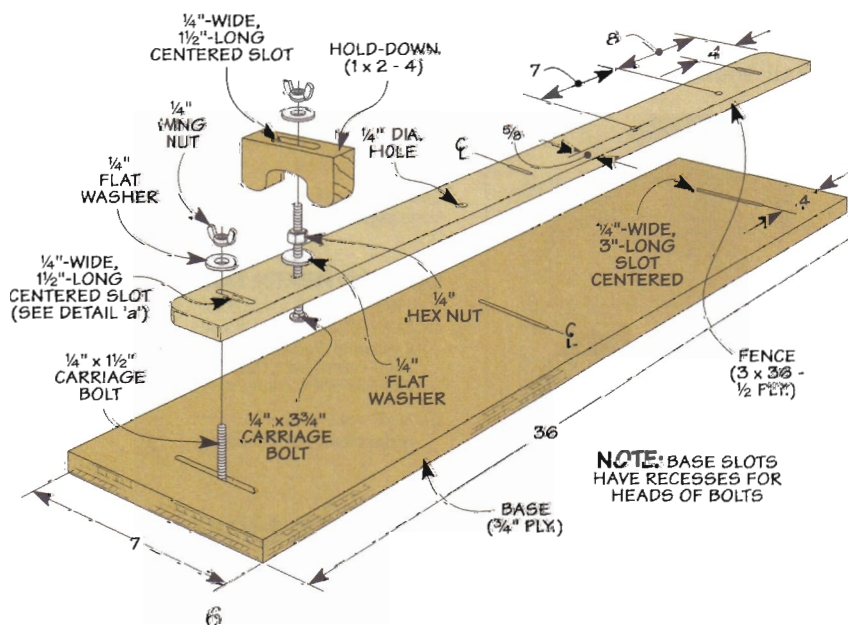

Hide-Away Workbench

Workspace is at a premium in my small shop. So I built a workbench that folds down from the wall like an ironing board.

I made it sturdy enough to handle most tasks. But best of all, it folds away into the wall when I don't need to use it.

The workbench is easy to build. It's sized to fit into the space between two wall studs. The top is simply a piece of 3/4" MDF.

A 2x4 wall support between the studs provides an anchor point for the bench. And a pair of hinges fastens the bench to the wall support. This makes it easy to pull the bench down and store it away again.

A stabilizing leg, attached to the end of the workbench with a hinge, can be quickly lowered to support the bench. The leg folds out of the way to store the bench in the wall.

*Ernie Moreau
Kelowna, British Columbia*

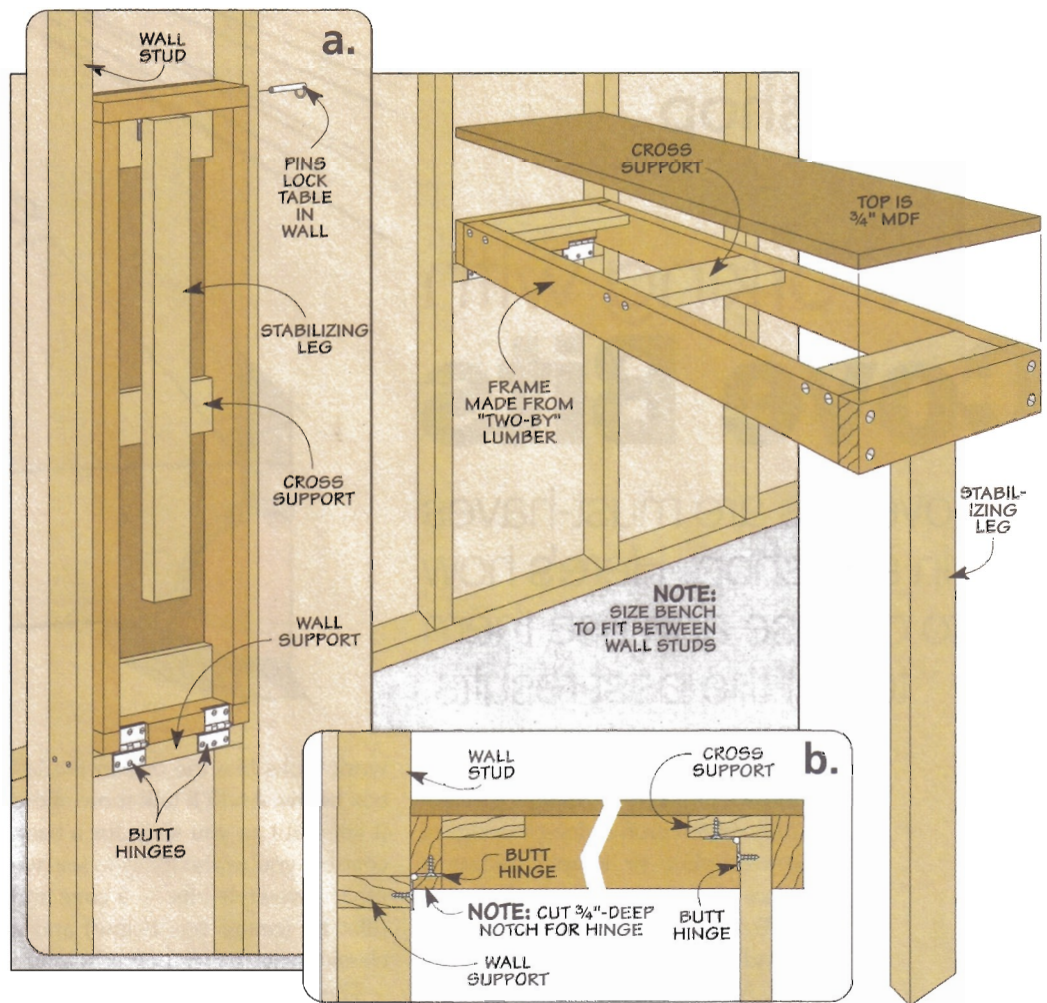

Quick Tips

► To help prevent rust formation, Ed Grabnski of Lansing, IL, places silica gel crystals in a used film canister with holes punched in the top. Then he slips the canister in with his tools.



▼ Erik Mason of Sherbrooke, Quebec, Canada uses steel drywall corner braces for making shelves. He simply cuts the corner piece to size and then mounts it to the wall stud. These simple "brackets" hold a plywood shelf in place.



▲ Beth Pollnow of Appleton, WI, uses metal binder clips to hold folded band saw blades. Then she simply hangs the clip on the wall for easy storage.

working with Cove Bits

Cove bits are must-haves in any shop. Here's how to choose and use them to get the best results.

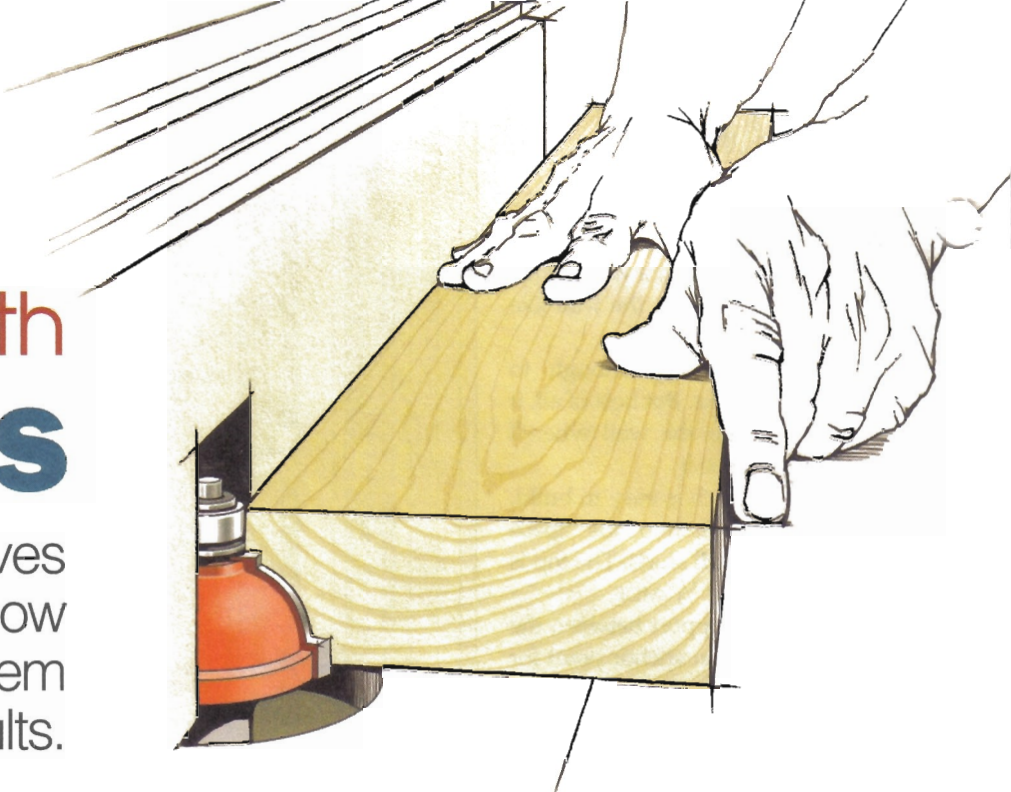

■ The details are what really make or break a project — whether it's a carefully routed profile along the edge of a workpiece or simply adding a piece of trim to set off a project.

For many of my projects, I handle this by reaching for a cove bit. A cove bit is the "mating" profile to a roundover bit. But instead of rounding over the outside edge of a workpiece, a cove bit "scoops" out material along the edge to create a round recess, like the you see in the drawing above.

Types of Cove Bits. The cove bit I use most often for this type of

work looks like the one in the left box below. And I'll talk more about it later. But as you shop for a basic cove bit, you're also likely to see two other cove-style bits — a cove and fillet bit (center box below) and a classical cove bit (right box below).

These two bits are used to cut more specialized cove profiles with fillets on the top and bottom of the cove. You'll often find these profiles on more traditional-looking furniture and millwork.

If you take a close look at each profile, you'll see that each bit is really identical. The only difference

is the size of the bearing. So you only need to buy one style of bit or the other. You can simply change the bearing to get the other profile. Note: These special bits only come in two different sizes ($\frac{3}{16}$ " and $\frac{5}{16}$ " radius).

Start with Basic Cove Bits. The basic cove bits are the workhorse bits in my shop. But unfortunately, a cove bit isn't one-size-fits-all. Some router bits, like a chamfer bit, will cut a wide range of sizes. But a cove bit will only create a cove of a single, specific radius.

If you check out the drawing at the top of the opposite page, you'll

Cove Profile

The standard cove bit you see below makes it easy to rout a smooth, decorative edge on a wide range of furniture projects and trim pieces.

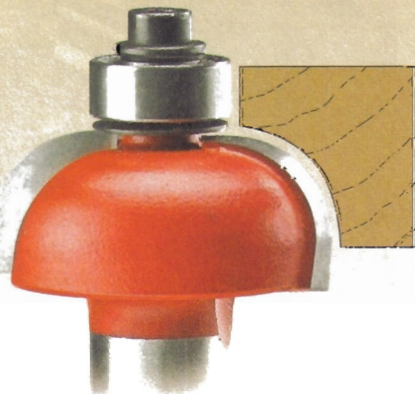

Cove & Fillet

Adding a small fillet near one end of the cove bit creates a profile found on more traditional-looking pieces of furniture and millwork.

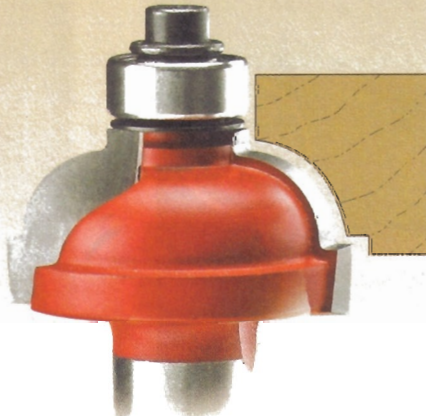

Classical Cove

The classical cove bit adds a second fillet to the profile of a cove and fillet bit, allowing additional enhancement of furniture and millwork.



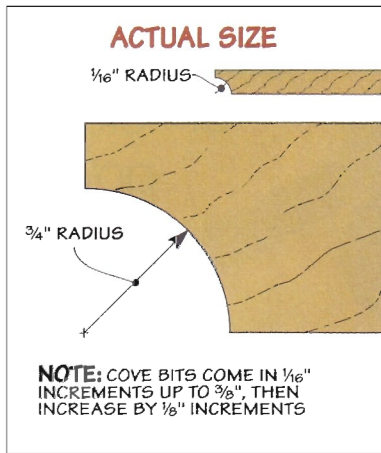

▲ **Range of Sizes.** You can find bits to rout coves from a tiny $\frac{1}{16}$ " radius all the way up to an impressive $\frac{3}{4}$ ".

see that cove bits start at $\frac{1}{16}$ " and go all the way up to $\frac{3}{4}$ " radius (and even 1" with some manufacturers). So buying an entire set can be a sizable investment. For the projects I build, a $\frac{1}{4}$ ", $\frac{3}{8}$ ", and $\frac{1}{2}$ " cove bit will handle just about any task. (For sources, see page 51).

Making Cove Trim. Most often, I'll use a cove bit to make small pieces of trim for a project. To do this safely, I turn to my router table and start with an extra-wide workpiece, like you see in the lower detail at right.

Doing this makes it easy to quickly and safely rout a cove

along each edge first. And once the coves are routed, creating the trim pieces is just a matter of ripping them free, like you see in the lower drawing at right.

Making a Smooth Cut. When you're routing the profile, a single pass will work fine for small coves. But larger cove bits remove a lot of material. So it's best to make a series of light passes, as in the drawing at right.

You'll find light passes leave a smoother cut. Plus, it also puts less stress on the router and bit, prolonging bit life. So, how much should you take in one pass? I try not to rout more than a $\frac{1}{4}$ " in depth on any cut. And even less on the final pass.

On the final pass, I take an even lighter cut ($\frac{1}{8}$ " or less). This is really just a clean up pass to get to final depth and remove any dips or other tool marks left from the other passes.

Dealing with Tearout. Using the right bit and technique goes a long way toward routing a smooth cove. But you may find it won't always prevent tearout, especially when you're routing a cove on end grain.

When this is the case, there are a couple steps you can take to prevent tearout. You can read all about that in the box below. 🛠️

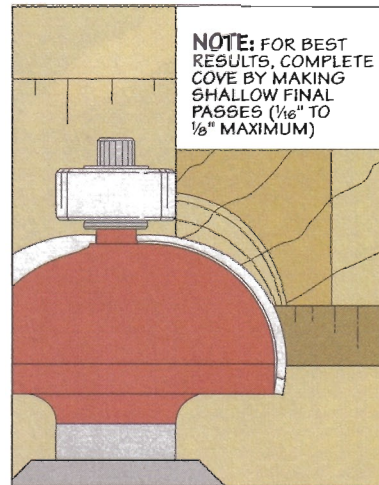

◀ **Multiple Passes.** Since larger cove bits remove so much material, you'll get the best results by limiting the depth of cut and making multiple passes.

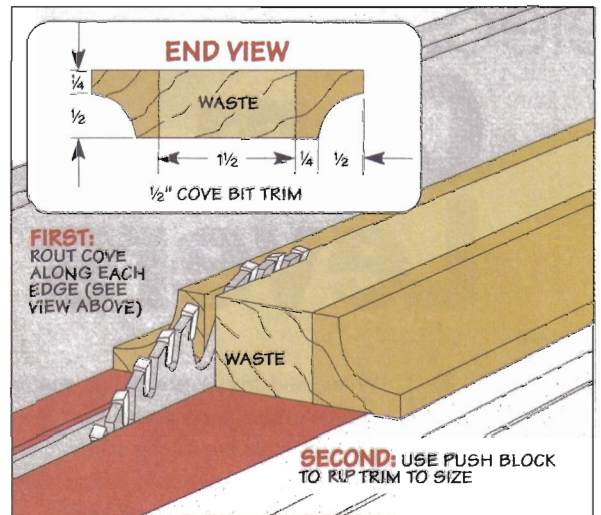

▲ **Small Pieces.** For trim, rout the cove on extra-wide stock and then rip the cove molding to final size.

Preventing Tearout

As with most routing tasks, the main thing you have to be concerned about when routing a cove is tearout. Most of the time, this happens while routing end grain. The problem is that the wood fibers on the corner of the board are unsupported and split away instead of being cut.

Solving the Problem. I've found there are a few things you can do to prevent or minimize tearout. As mentioned earlier, one of the easiest ways to prevent tearout is to form the cove by making multiple passes. A couple very light passes at the end should solve the problem. But even that might not always work.

Proper Sequence. A second way to avoid tearout involves the sequence of routing. When I need to rout a cove all the way around a piece, I rout the end grain first. This way, if the corner chips, the tearout will be cut away as I rout the long grain.

Back Up the Workpiece. But what do you do if you only need to rout your cove along the end grain? An easy

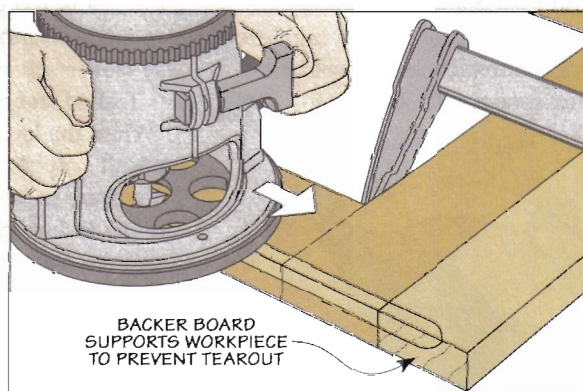

solution is to clamp a backer board of the same thickness to the workpiece at the end of the cut, as in the drawing above. The backer board supports the fragile corner, keeping it from chipping out.

Backrout. And there's one other solution. You can backrout the end of the workpiece first. Then go to the opposite end and rout the rest of the cove.

SHOP TIP

This versatile accessory packs a load of holding power.

quick-release Cam Levers

■ When making a shop jig, many woodworkers turn to various types of knobs to make the jig adjustable. But there's another option that may not be so obvious — cam levers.

Cam levers, also known as quick-release levers, can make working with jigs and fixtures quick and easy, especially when you're doing repetitive work.

You've probably used cam levers without realizing it. Most table saw fences are locked into

place by a cam lever, as are many aluminum tool guides and back-to-back bench clamps. Some routers even use a cam lever to "lock in" the bit depth.

How It Works. A cam lever rotates around a pin called a cross dowel. The lower drawing at left shows how the pivot point on the wide, rounded part of the cam lever is a little off-center (called an eccentric cam).

When the lever is "up," the cam doesn't apply any pressure. However, as you push the lever down, it begins exerting downward force to lock your jig or fixture down tight. And the further you push the lever down, the more pressure you're going to get.

Quick Release. And what's so nice about these clamps is the pressure is released immediately when the lever is flipped back up. It's much easier and quicker to flip a lever than turn a knob.

Cam levers are especially useful as a time-saver when used with a slot or T-track. You just flip up the

lever, slide the part where you want it, and simply push the lever back down to lock it into place. I've replaced all the knobs on my stop blocks and fences with cam levers because the quick-release feature is a real time-saver.

WORKING WITH CAM LEVERS

When you buy cam levers, you'll get the lever along with a threaded cross dowel (For sources, see page 51). You simply insert the cross dowel into the lever so that the threaded hole is between the lever's "wings." The hole will take either a $\frac{5}{16}$ "-18 or a $\frac{1}{4}$ "-20 bolt or threaded rod, depending on the size of cam lever you bought. These are the two most popular sizes for cam levers. You can see different styles in the box on the far right of the next page.

Bolts and Rods. You can use a flange, hex, or stove bolt, or threaded rod to anchor your cam lever, depending on your application. The bolt or rod should extend above the hole to give the cross

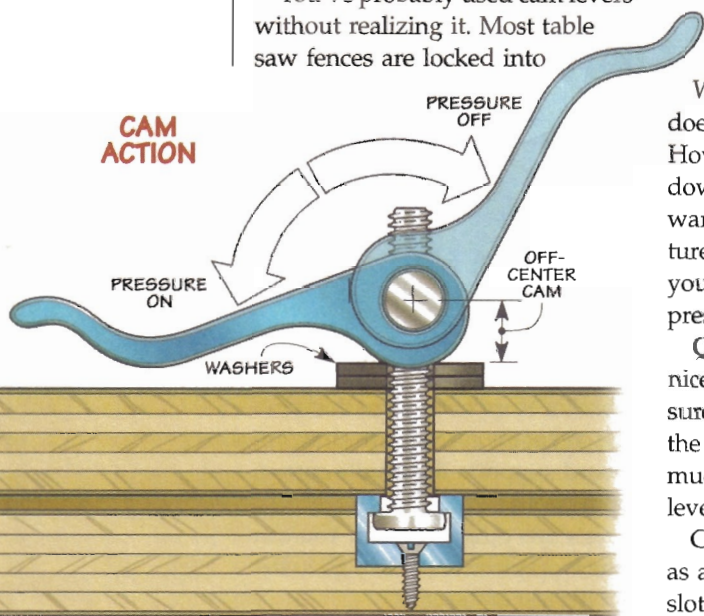

dowel plenty of thread to grip. But it shouldn't extend too much above the hole, or it'll interfere with the quick-release action of the lever.

CAM VS. KNOB

A cam lever is installed just like a knob. After sliding a washer over the bolt, simply rotate the lever until it touches the washer, like you would install a knob.

Unlike a knob, however, you can push the lever down toward the wide side of the cam to add more holding power. Remember, the lever doesn't have to be completely horizontal to work.

When you're finished, just flip the lever back to the up position to loosen its grip. You don't have to rotate the lever to release the pressure like you do a knob.

ADJUSTING THE LEVER

If you need the lever to lie as flat as possible, all you have to do is unscrew the lever a little bit at a time until you get the clamping pressure and lever position you want. Depending on your application, though, there may be times

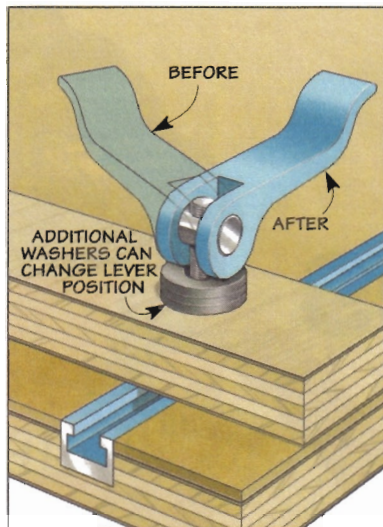

when you just can't change the orientation of the lever.

The remedy is to adjust the space between the lever and the jig (drawing above). You can do this by adding washers or using thicker or thinner washers. Some manufacturers include different washers with their cam levers.

So the next time you need to build a shop jig or fixture, give cam levers a try. They could become one of the most useful and time-saving tools in your shop. 

Going Sideways

The cam levers mentioned above are designed to apply downward pressure to a jig or workpiece.

Shop Fox has gone another direction and developed a low-profile cam lever that applies pressure sideways.

How this cam works is that you first slide it into a T-track and push it firmly against your workpiece (see photo). Next, tighten the hex screw in the handle to secure the clamp. Then move the handle from one side to the other to tighten the jaw against the workpiece.

Another feature is that the jaw is set at an angle to provide not only horizontal pressure, but also

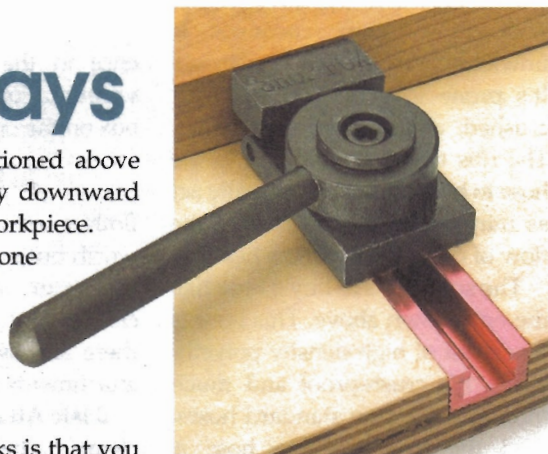

▲ **Cam Clamp.** This clamp slides along a T-track and leaves the top of your project unobstructed.

downward force to keep your workpiece flat. It's low profile makes it perfect for holding your project while sanding. Other uses include holding panels and picture frames together during glueup.

it's all In The Flip

As you can see in the photos below, not all cam levers are the same. While they all operate on the same principle, they come in various sizes and shapes. What surprised me while I was working with these levers is that their small size didn't translate to small holding power — these cams can generate a lot of downward force.

Lee Valley



◀ **Small Size, but Strong.** This compact cam lever from Lee Valley comes with extra washers to allow you to change the lever orientation and clamping pressure. The slotted cross dowel makes the cam lever easy to assemble.

Rockler

► Easier Grip.

This Rockler cam lever is a little larger than the one above and comes with nylon washers, but the cross dowel isn't slotted. What I like about this lever is that the end curves up, making it easier to get your finger under the cam when you need to release its grip.

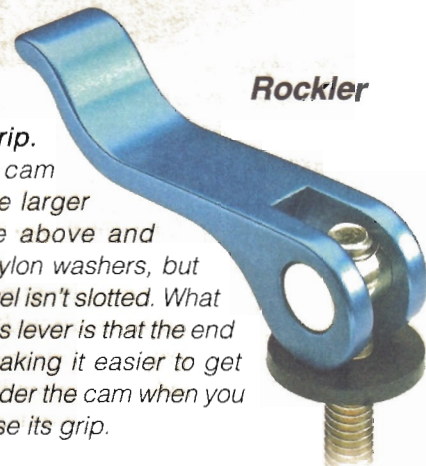

Woodhaven

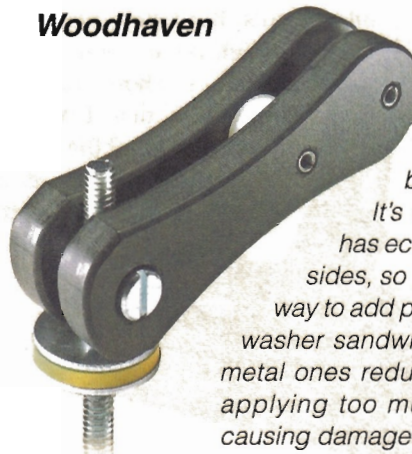

◀ **Two Levers Acting as One.** This lever from Woodhaven is the beefiest of the three. It's dual-action design has eccentric cams on two sides, so you can flip it either way to add pressure. The rubber washer sandwiched between two metal ones reduces the chance of applying too much pressure and causing damage.

shop vacuum Upgrades

A few accessories will turn your shop vacuum into the ultimate clean-up tool.



Crush-Proof Hose. ▲
This polyethylene hose is strong, yet flexible. And it has smooth walls to maximize airflow.

Claw Tool. ▶
A large claw tool makes cleaning up around the shop quick and easy.

◀ **Crevice Tool.**
For reaching into narrow, tight spaces, a crevice tool can't be beat.

Like most woodworkers, I purchased my shop vacuum with one purpose in mind — to suck up sawdust around the shop. But the truth is, a shop vacuum can do a whole lot more than that. With the right accessories, you can use a shop vacuum for all sorts of tasks — both in and out of the shop.

Upgrades. A lot of these accessories come in the form of hose attachments. But before we begin talking about these, there are a couple of shop vacuum “upgrades” that I would invest in right off the bat.

The first of these is a better hose. The stiff,

plastic hose that typically comes with most shop vacuums is unwieldy and difficult to manage. It's prone to getting kinked and crushed, and collapsing on itself. The ribs that are molded into the hose to help reinforce it actually act as mini-roadblocks, impeding the flow of debris through the hose.

The solution is to buy a hose like the one shown above. This hose is made out of high-density polyethylene. It's crush-proof and much more flexible than standard hoses. And the inside of the hose is smooth, so debris passes through it easier, with less chance of clogging.

And best of all, the hose is available in 12' and 24' lengths, so you don't have to pull your shop vacuum around behind you as you clean up. For sources, see page 51.

The second upgrade on my “must-have” list is a new filter. Replacing the standard-issue,

paper-element filter with a better quality one really makes a difference in the performance of the vacuum. For more on this, see the box on the opposite page.

ATTACHMENTS

Both a new hose and filter are worth buying, even if all you ever use your shop vacuum for is cleaning off your workbench. But there are also some pretty handy attachments on the market.

Basic Attachments. For general cleanup, there are two main tools that I use (see photo above). For most cleanup jobs, I use a claw tool. It allows you to cover a fairly wide surface area, but it's still small enough to fit into most spaces. And for spots that are just too tight for the claw tool, a crevice tool comes in handy.

Floor Sweeper. Although you can use a claw tool to sweep up

Sweeper Head.
Flipping a lever on this sweeper attachment raises or lowers the brushes for different types of flooring. ▶

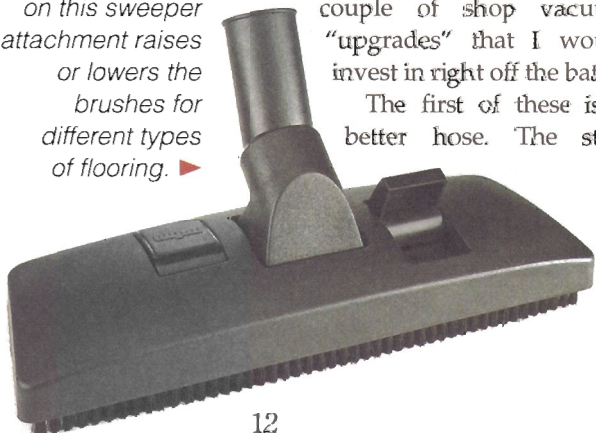

Universal Adapter.
Steps on this fitting allow you to connect your vacuum to most attachments. ▼



debris from the floor of your shop, a floor sweeper works faster. (And saves your back too, if you use an extension wand along with it.) The sweeper shown on the opposite page has a "high-low" feature. By flipping a lever on top of the sweeper head, you can raise or

lower the height of the head for different types of floor surfaces.

Micro Tool Kit. For delicate cleaning jobs, a micro tool kit works great. As you can see in the photo at left, these attachments look like the larger versions — they're just smaller. You can use them to clean everything from shop tools to your computer keyboard.

Adapter. Most newer shop tools have some sort of dust collection port built into them. The problem is that these dust ports come in several different sizes, so it's not always easy to hook up a dust collector or shop vacuum to the tool you're using. That's where a universal adapter, like the one shown above, comes in handy.

◀ **Micro Tool Kit.** These micro tools are really just scaled down versions of larger shop vacuum attachments.

One end of this attachment has a series of stepped fittings. This allows you to "hook up" to most power tools without having to use a dedicated hose fitting.

Inflator. If you've ever gotten light-headed from trying to blow up an air mattress, this last attachment is one that you'll really appreciate. It's an inflator nozzle (see photo at right).

Most shop vacuums allow you to connect the hose to an exhaust port on the vacuum in order to blow air. By putting this inflator attachment on the other end of the hose, you can use your shop vacuum to blow up most inflatable items.

You may not have a need for all of the attachments mentioned above. But adding even a few can improve the versatility of your shop vacuum and help you keep a cleaner shop as well. 🛠️

▲ **Clearing the Air.**
By using a hose adaptor to connect to individual tools, you can turn your shop vacuum into a dust collector.



▲ **Inflator Nozzle.**
Using this nozzle, you can turn your shop vacuum into an air inflator.

Vacuum Upgrade: Finer Filters

Right out of the box, a shop vacuum works great. But after awhile, you'll probably start to notice a decrease in the suction power. That's because the pleated paper filter that comes with your shop vacuum gets clogged with dust and blocks the air flow.

Cleaning the filter helps a little, but it's nearly impossible to blow out all the dust that get's packed into the pleats of the filter. That's why I replaced the stock filter on my shop vacuum with a *CleanStream* filter like the one shown in the photo at right.

CleanStream filters are made out of *Gore-Tex*, the same waterproof material that's used on some types of rain gear. What makes these filters work so well is the fact that dust particles won't cling to the *Gore-Tex*. So as soon as you turn the shop vacuum off, all the dust falls away from the filter and to the bottom of the vacuum canister.

CleanStream filters are also made to HEPA (High Efficiency Particle Arrestor) standards. So they remove 99.97% of all dust particles down to 0.3 microns in size. For sources, see page 51.



▲ **No More Paper Filters.** Because the material used in this *CleanStream* filter is waterproof, you can clean it by spraying it off with a garden hose.

Shop Short Cuts

2-In-1 Insert Installation Jig



▲ **Threaded Inserts.** Adding threaded inserts to a project allows you to join parts so they can be easily adjusted or removed.

Threaded inserts, like the ones at left, are handy pieces of hardware. With an insert or two (and some fasteners), you can make a jig or fixture easily adjustable. And a set of inserts work great on cabinets where you may need to allow for quick and easy disassembly.

The challenge with threaded inserts is installing them so they're perfectly square, which isn't always an easy task — especially in the middle of a workpiece.

Insert Jig. To solve this problem, I use a handy installation jig like you see in the photo above. The jig is just a block of hardwood with a notch at each end, as illustrated in the drawing below.

The two notches allow you to install either 1/4" or 5/16" threaded inserts. They're the two sizes I use most often.

The key to how the jig works is some basic hardware installed at

each end. You can see how everything goes together in detail 'a.'

The notch provides clearance for a nut, washer, and threaded insert. And a deep counterbore accepts a nylon spacer and spring that keep the bolt and insert perfectly square to the workpiece during the installation.

Before you assemble the hardware, you'll need to cut off a portion of the threads on the bolt so there's about 3/4" remaining. This way, the end of the bolt won't extend beyond the end of the insert once it's installed.

Installing an Insert. Using the jig is really quite simple. The first thing you'll need to do is drill a hole in the workpiece to match the body of the insert (drawing below right).

But don't install the insert just yet. If you do, the threads on the insert can "lift" the edges of the hole

slightly (detail 'b') — especially on a workpiece with thin veneer or plastic laminate. To prevent this, I like to drill a small countersink around the edge of the hole.

Next, slip a washer onto the bolt and thread the insert on. Then set the jig (and insert) in place over the hole. Firmly press the jig down so the end of the insert seats itself in the hole. Now it's just a matter of turning the head of the bolt with a ratchet until the threads start cutting into the wood. Then just continue turning until the insert is flush with the surface. Note: A little wax on the threads of the insert will make the installation easier.

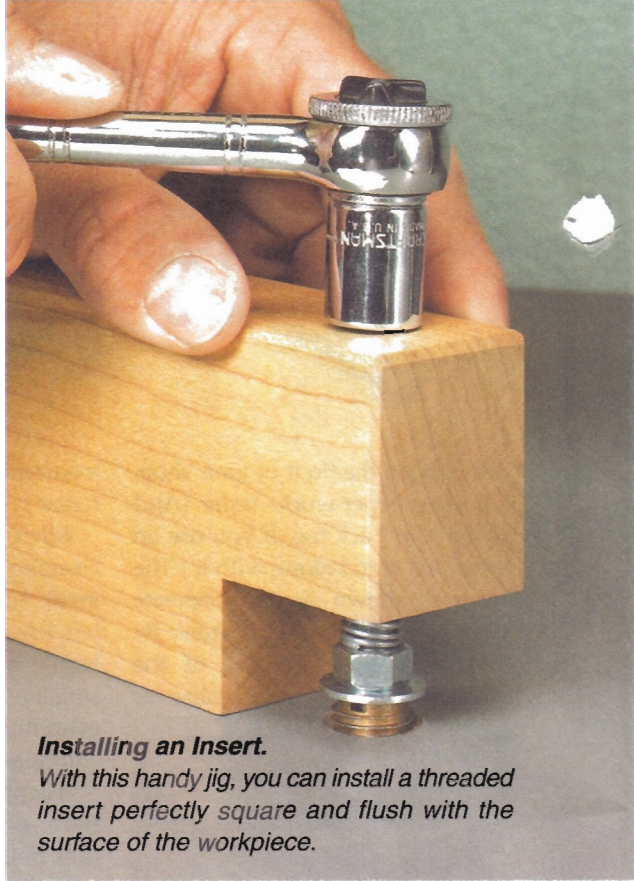

Installing an Insert.
With this handy jig, you can install a threaded insert perfectly square and flush with the surface of the workpiece.

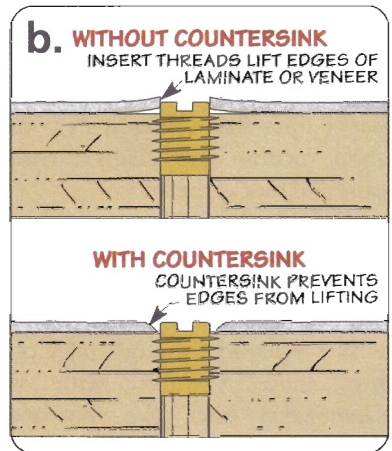
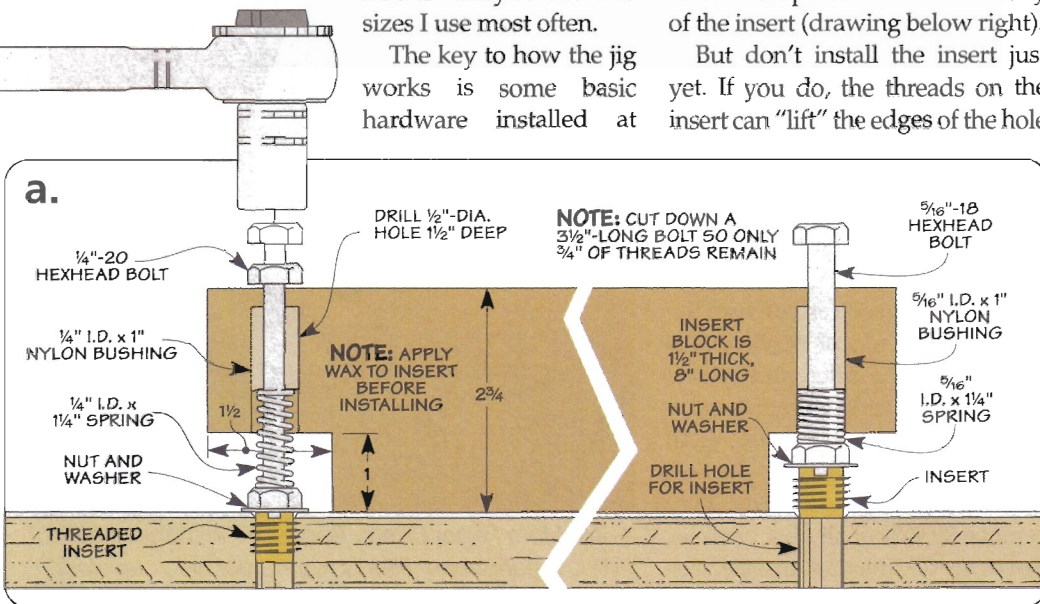

From Thick to Thin — Resawing on the Table Saw

Normally, I like to use a band saw for resawing (for more on this, you can refer to the article on page 30). But if you don't own a band saw and the pieces you're resawing aren't too wide (up to 6"), you can resaw them on your table saw.

Resawing on the table saw is basically a ripping operation. But instead of the board lying on its face, it's fed through the blade standing on edge, like you see in the photo at right.

Setting It Up Right. The first thing I do when setting up to resaw is to change saw blades. Although you can use a combination blade to resaw, a 24-tooth rip blade will give you a smoother cut. Plus, a rip blade is thicker, so there's less tendency for it to flex while cutting.

Next, I replace my table saw insert with a shop-made insert that is fitted with a splitter, as illustrated in the box below.

Finally, since I want as much control over the workpiece as possible, I attach a tall auxiliary fence to the rip fence, as shown in Figure 1.

Making the Cut. To make the cut, I set the fence to resaw the board about $\frac{1}{16}$ " thicker than the final desired thickness. Then, after I finish resawing, I remove the marks left by the blade with a hand plane or thickness planer.

Begin resawing by pressing the workpiece firmly against the fence. (A featherboard clamped to the saw table can help here.) Then, use a thick push block to feed the board through the blade. Note: Use a push block that hooks over the back of the workpiece, as in Figure 1.

I usually make the cut in a series of passes. After making the first pass, flip the piece end for end

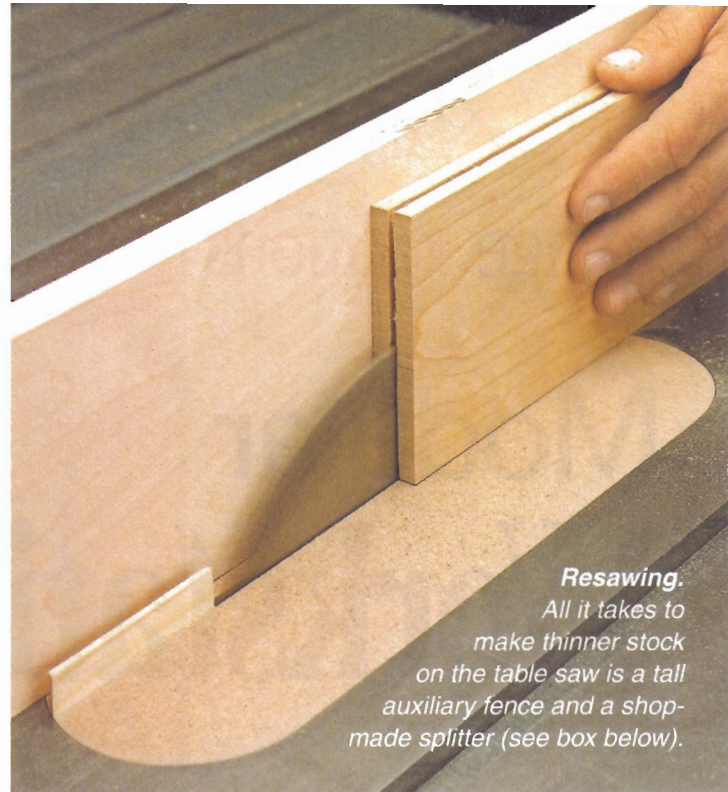

Resawing. All it takes to make thinner stock on the table saw is a tall auxiliary fence and a shop-made splitter (see box below).

(keeping the same face against the fence) and make a second cut on the opposite edge (Figure 1).

On stock that's 3" wide or less, I try to complete the cut with the second pass. The fewer cuts you have to make, the less cleanup work you'll have to do later.

If the stock is wider than 3", raise the blade in $\frac{1}{2}$ " increments and run both edges through the saw a second time. Continue raising the blade in $\frac{1}{2}$ " increments until you've completed the cut.

Dealing with Wide Boards. If the stock is wider than the capacity of your table saw (about 6" for most saws), you can use a hand saw to complete the cut. A rip saw works best for this.

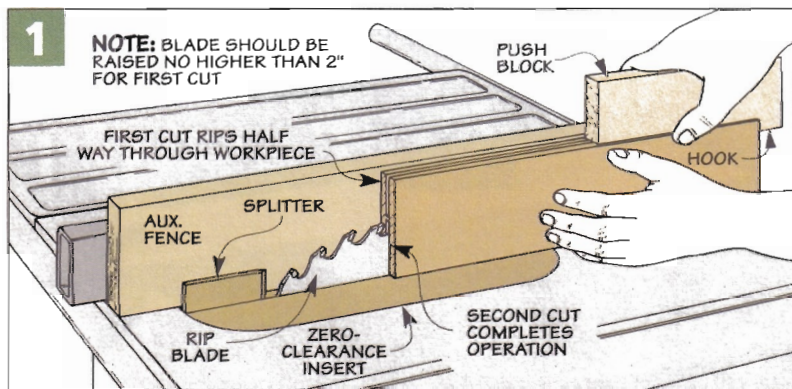

Shop-Made Splitter Insert

Whenever you resaw thin stock on the table saw, it's a good idea to use a zero-clearance insert with a splitter, like the one shown at right or an after-market model like the *Micro Jig* splitter on page 47.

The insert prevents the workpiece from slipping down between the blade and the opening. And the splitter keeps the wood from "pinching" the back of the saw blade and kicking back at you.

I make my inserts out of MDF, but plywood works just as well. To ensure a good

fit, use the insert that came with your saw as a template for laying out the new one.

Once you have the insert sized to fit your saw, all that's left to do is cut a kerf to match the position of the saw blade. Then, you can glue in a splitter made from a piece of $\frac{1}{8}$ " hardboard.

Finally, it's important for the insert to be level with the top of the saw table. If you need to raise the insert slightly, you can install a set of flathead screws underneath to act as adjustable feet.

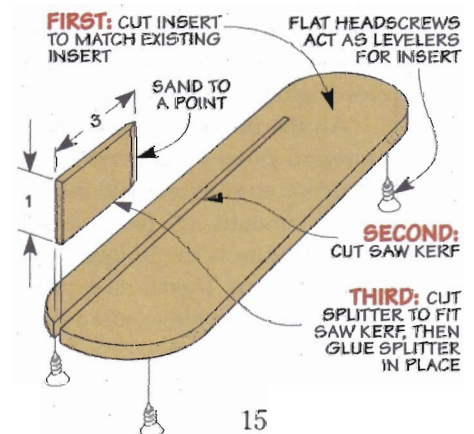

storage solutions

Modular Workstation

Whether you build one or all three, these simple projects are a great way to keep your shop more organized.

Who couldn't use extra storage in their shop or garage? The challenge is coming up with a solution that works for the space you have. That's where the trio of projects you see here comes in.

Individually, the wall cabinet, work table, and roll-around cart offer some versatile options for keeping your woodworking tools, hardware, or car care supplies close at hand. But if you build all three, they fit together as an all-in-one storage center that doesn't take up a lot of space (photos at right).

All the projects feature straightforward joinery and plywood construction so you can build them in a short amount of time. Another great feature is the unique drawer guide system. There's no expensive hardware to buy here, just a simple, shop-built solution.



◀ **Roll-Around Cart.** An important part of the workstation, this roll-around cart will keep your tools within easy reach. It's designed to tuck under the work table.

Exploded View Details

OVERALL DIMENSIONS: (SEE MARGIN AT RIGHT)

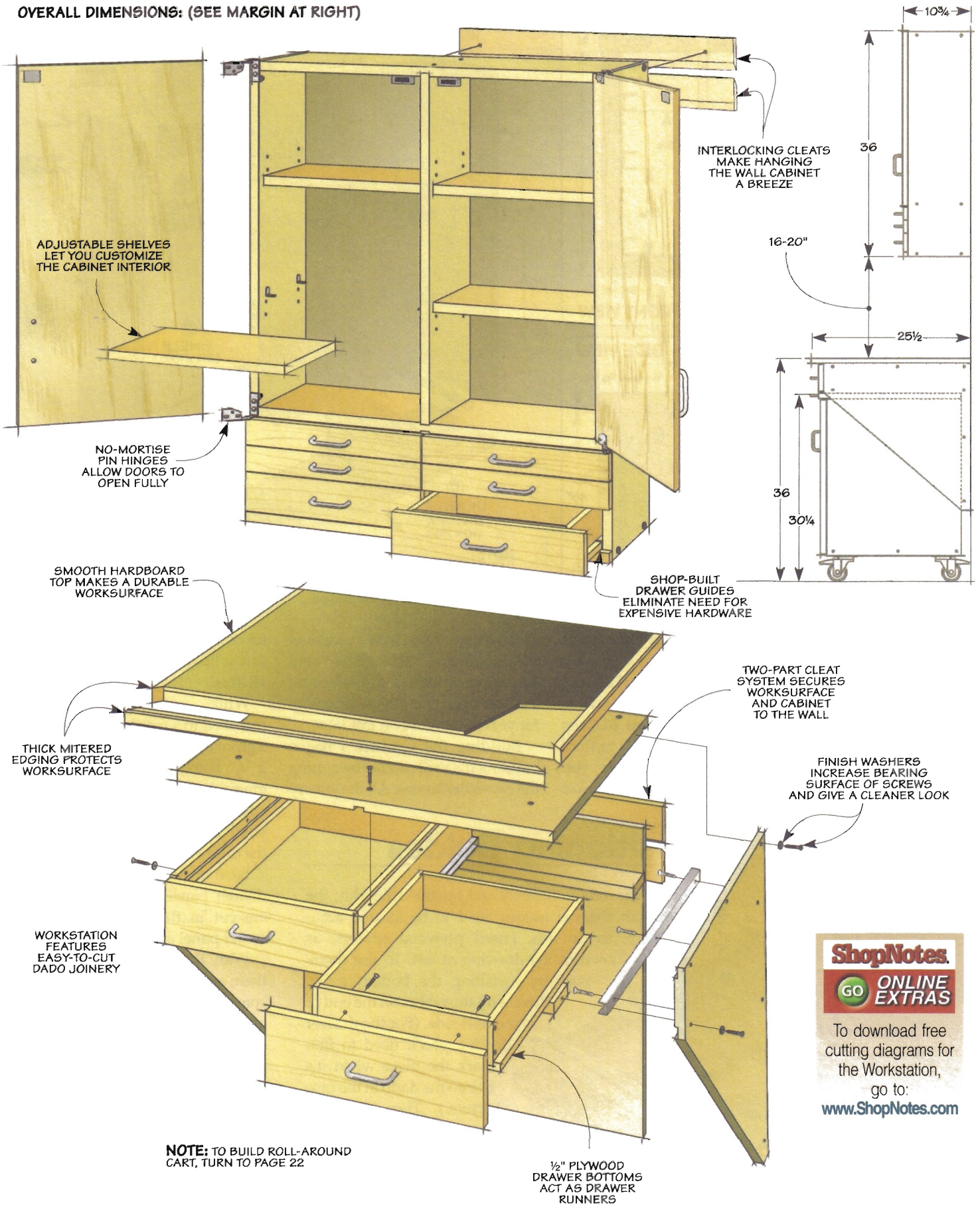

ShopNotes
 GO ONLINE EXTRAS
 To download free cutting diagrams for the Workstation, go to:
www.ShopNotes.com

building the Wall Cabinet

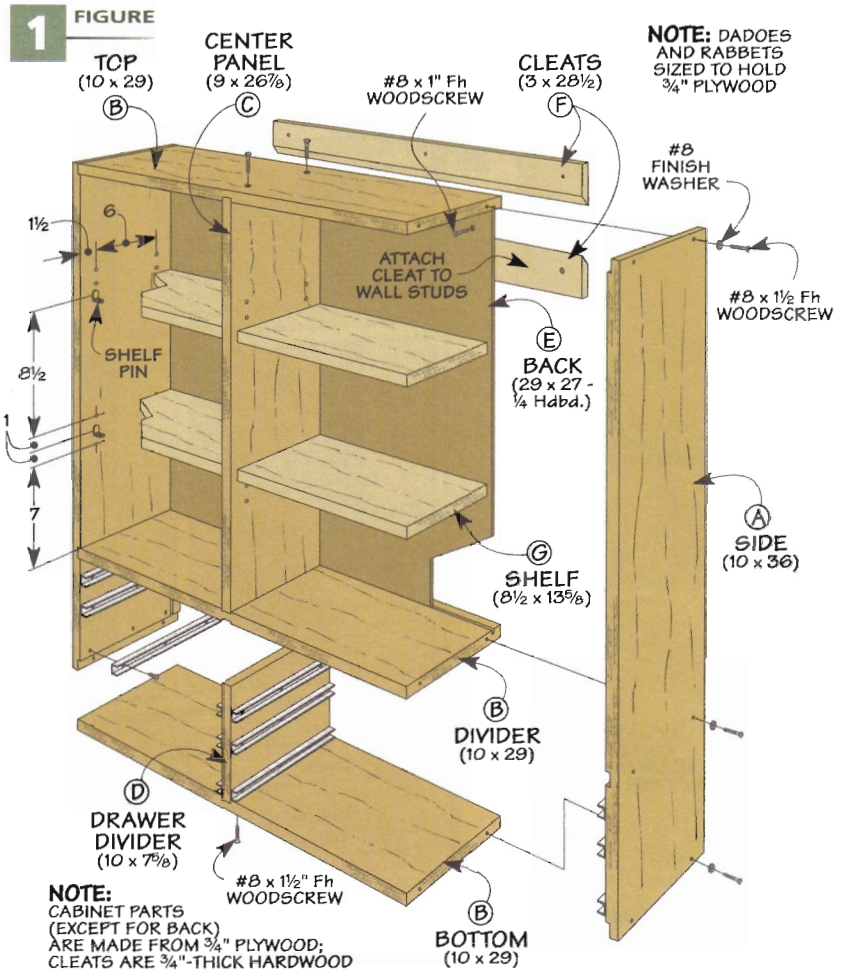
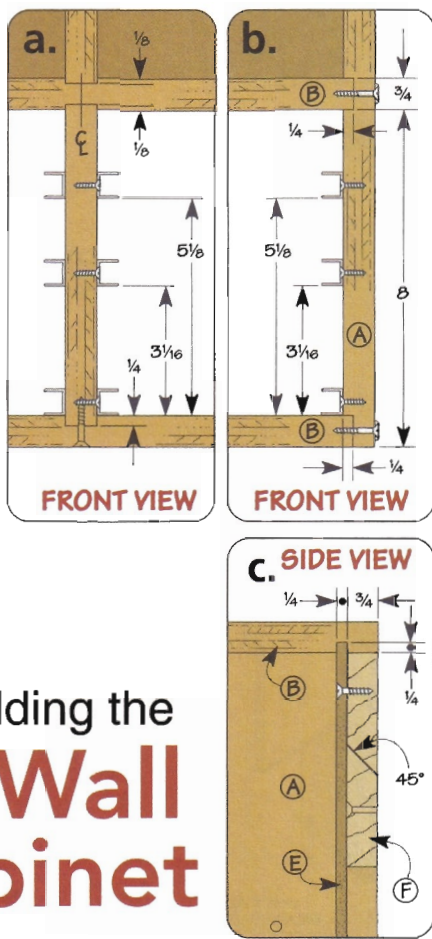

One of the things that I like about this wall cabinet is that it packs a lot of storage without taking up much space. With all the drawers and shelves, you're sure to keep things organized and easy to find. Speaking of the drawers, you won't find any expensive drawer

slides here. This simple cabinet uses a unique guide system and drawer construction to make sure the drawers will work smoothly for years. But more on this later.

Building the Cabinet. I began building the wall cabinet by cutting the case sides to size. All the joinery

for this piece can be cut at the table saw with a dado blade. You'll find all the details in Figures 1a and 1b.

While at the table saw, I switched to a regular blade and cut a groove near the back edge to hold a 1/4" hardboard back. This inset groove holds the back and creates a space for a two-part cleat that you'll build later. It's used to hang the cabinet on the wall.

Next up are the top, bottom, and divider panels. A series of dados are cut in these parts to hold a center panel and drawer divider.

With the joinery wrapped up, there are just a couple of details to complete before the cabinet can be assembled. The first thing to do is drill a set of shelf pin holes.

The other detail is to install some aluminum channels to act as drawer guides. The box at left shows you how it's done.

Cleats. That takes care of the cabinet construction. But before moving on to the doors and

Positioning Guides

For the drawers to be level and operate smoothly, the aluminum channel guides need to be located accurately. To do this, I used plywood spacers, as shown in the drawing at left. To use them, start by installing the bottom guide flush with the rabbet on the end of the case side. (For the drawer divider, you'll need to first mark the piece when it's fit into the dado in the case bottom.) Then I cut a spacer to position the middle drawer channel. After installing all the middle channels, you can trim the spacer down for the upper set of guides.

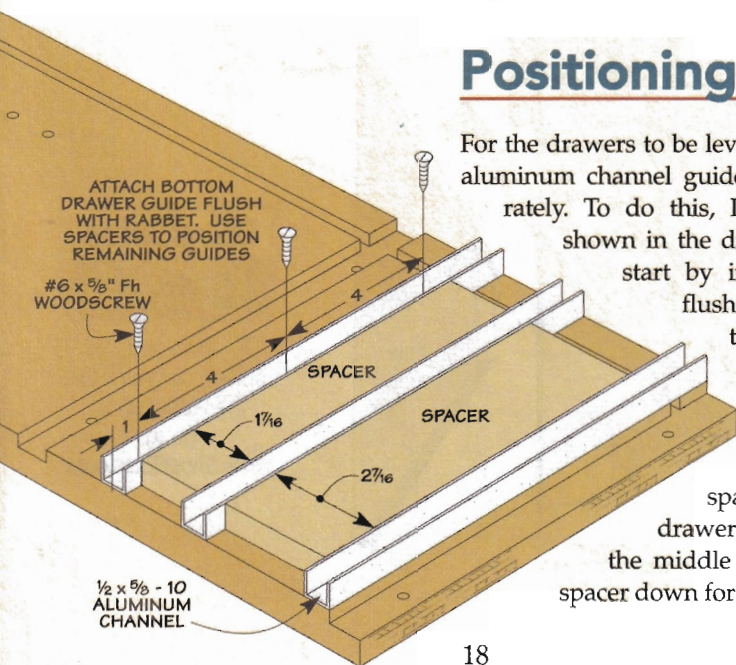

2 FIGURE

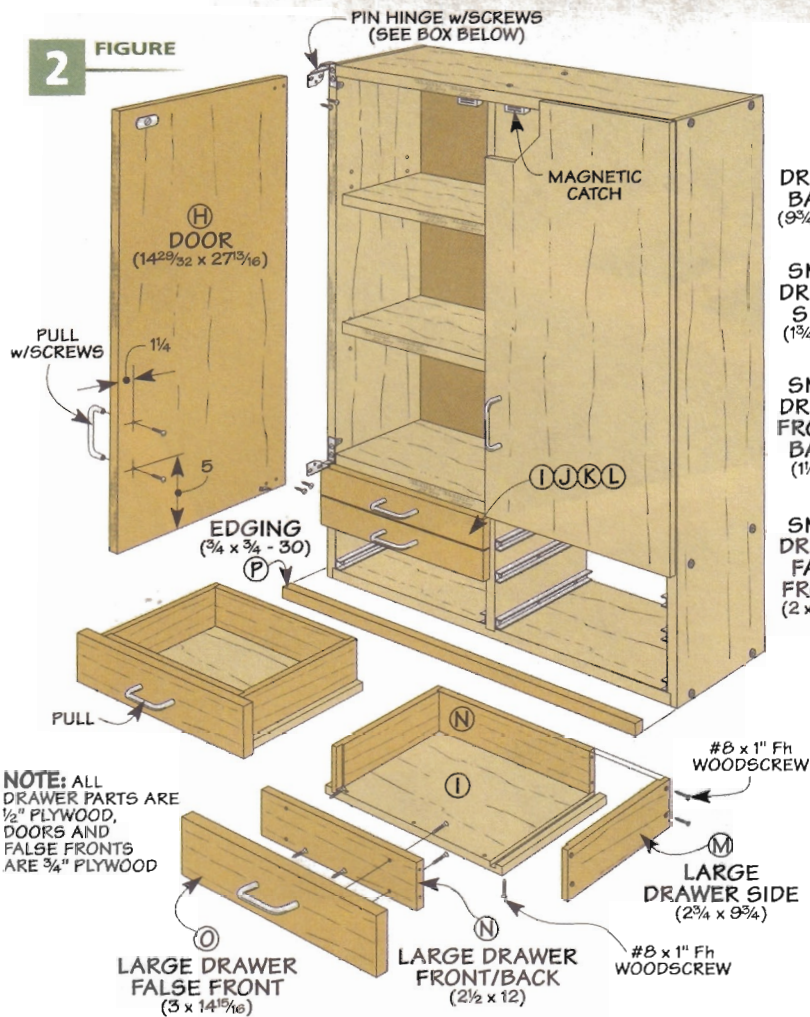

- I DRAWER BASES (9 3/4 x 13 3/4)
- J SMALL DRAWER SIDES (1 3/4 x 9 3/4)
- K SMALL DRAWER FRONTS/BACKS (1 1/2 x 12)
- L SMALL DRAWER FALSE FRONTS (2 x 14 15/16)

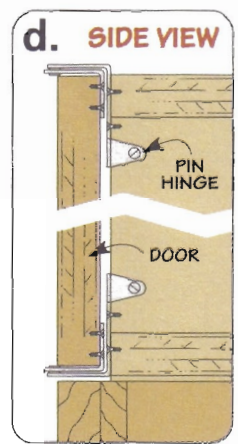
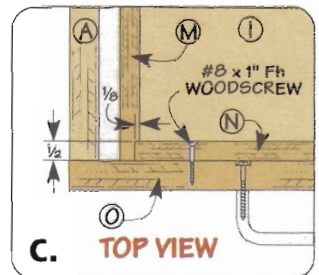
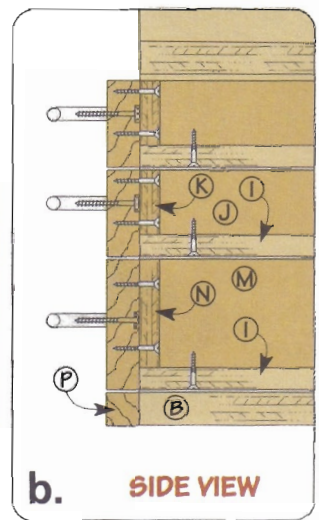
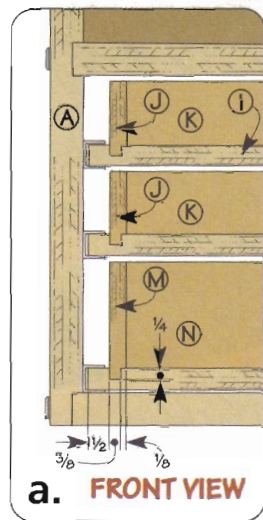

The sides have a tongue cut in the bottom and a rabbet cut on each end. These are sized to hold the drawer front and back, as shown in Figure 2b. The front and back rest on the drawer bottom. And since the joinery will be under a lot of stress, I added a few screws for extra strength.

The last drawer parts to add are the false fronts. To attach them, I fit the drawers in position and used carpet tape to hold the fronts in place and set the gaps. Then they can be screwed in place.

All that's left is to attach edging to the bottom of the case. It brings the case flush with the false fronts.

drawers, there's one more thing to add. To make it easy to hang the cabinet on the wall, I used a beveled cleat system. One cleat is screwed to the cabinet and the other is attached to the wall. (Be sure to screw into the studs.) The bevels on the mating edges of the cleats interlock to keep the cabinet in place, as shown in Figure 1c.

Doors and Shelves. Now that the case is complete, you can fit it out with adjustable shelves, doors, and drawers. The shelves are about as simple as they come. Just cut them to size and set them in place.

The doors are just as straightforward. The only difference is that you'll need to add some handles and hinges. The hinges I used are unique and you can learn more about them in the box at right.

Drawers. You'll notice that the drawers for this cabinet aren't your typical drawers. The bottom acts as a platform that the rest of the parts are added to. The bottom also

forms the runners that slide in the aluminum guides in the cabinet.

The trick here is to keep the drawer sides, front, and back square to the bottom. The simple solution is a pair of dadoes in the drawer bottom that register the sides and keep the box square.

No-Mortise Pin Hinges

These unique-looking hinges allow the cabinet doors to open wide and get at everything inside. Best of all, they're adjustable, which makes hanging the doors pretty simple.

To install them, start by screwing both of the hinges to the front edge of the cabinet. Since I wanted the doors flush with the top of the case, the hinges are positioned above the cabinet top. The bottom hinges are flush with the cabinet bottom (Figure 2d above). Use the two, vertical-slotted holes to do this. But don't tighten them down just yet.

Next, you can attach the door to the hinges using the horizontal-slotted

holes on the hinge leaf. Then adjust the cabinet side of the hinge so the door is flush with the cabinet top. After fine-tuning the fit and gaps, you can fix the hinges in place with the two remaining screws.

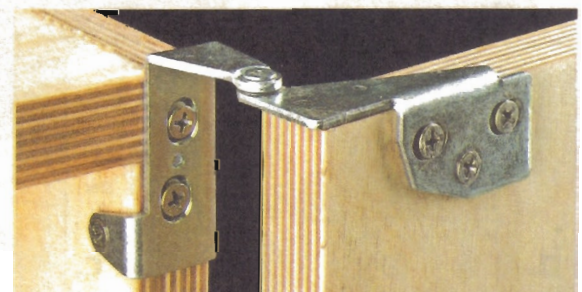

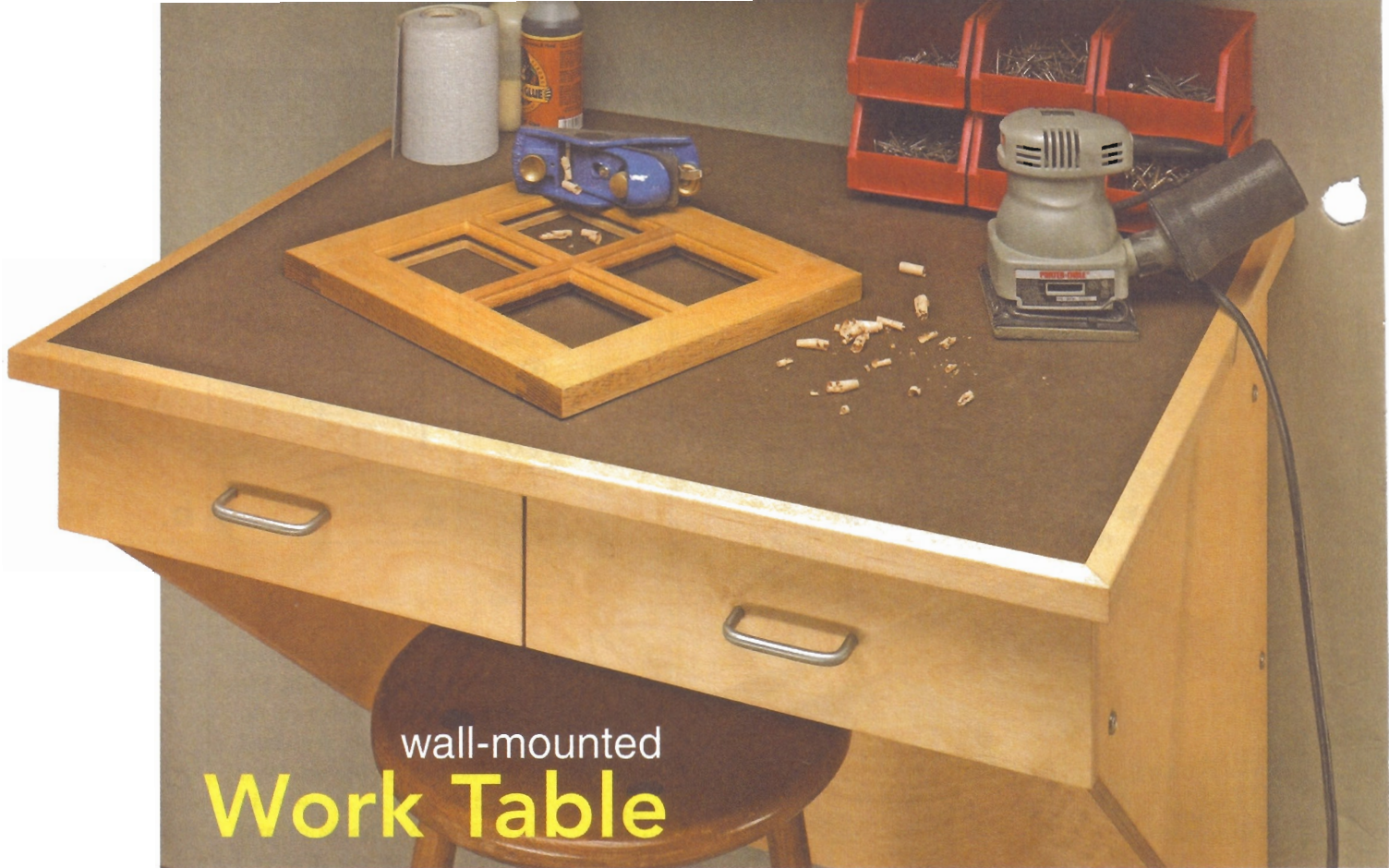

wall-mounted Work Table

Too often, my workbench is so cluttered that there isn't room to do anything. Even finding a place to trim a part to fit with a block plane, as you see in the photo above, can be hard to do. This easy-to-build work table is perfect for the job. It's

also a great spot to pull up a stool and sketch out some ideas, or lay out my plans without having to take up valuable bench space. Below the table, a pair of handy drawers can hold a pad of paper, pencils, and drafting supplies.

The work table is built similarly to a large wall shelf. A sturdy, plywood frame supports the top and drawers. And the work table is attached to the wall with the same cleat system used to hang the tool cabinet shown on page 18.

Building the Frame. I started building the work table by cutting the sides to size from $\frac{3}{4}$ " plywood. The angled sides support the top and hold the frame supports. Cutting the angled edges on big pieces like this with the table saw can be a little tricky. To make this easier to do, I turned to my circular saw. You can see how it's done in the box on the opposite page.

Now that the sides are sized, the next step is to cut some joinery. And for this, the table saw is the perfect choice. With a dado blade that matched the thickness of the plywood, I cut a rabbet at the top of each piece to hold a plywood subtop. Then a dado is cut below the rabbet to hold the drawer supports, as in Figure 1a. While you're at the table saw, you can cut a groove to hold the back.

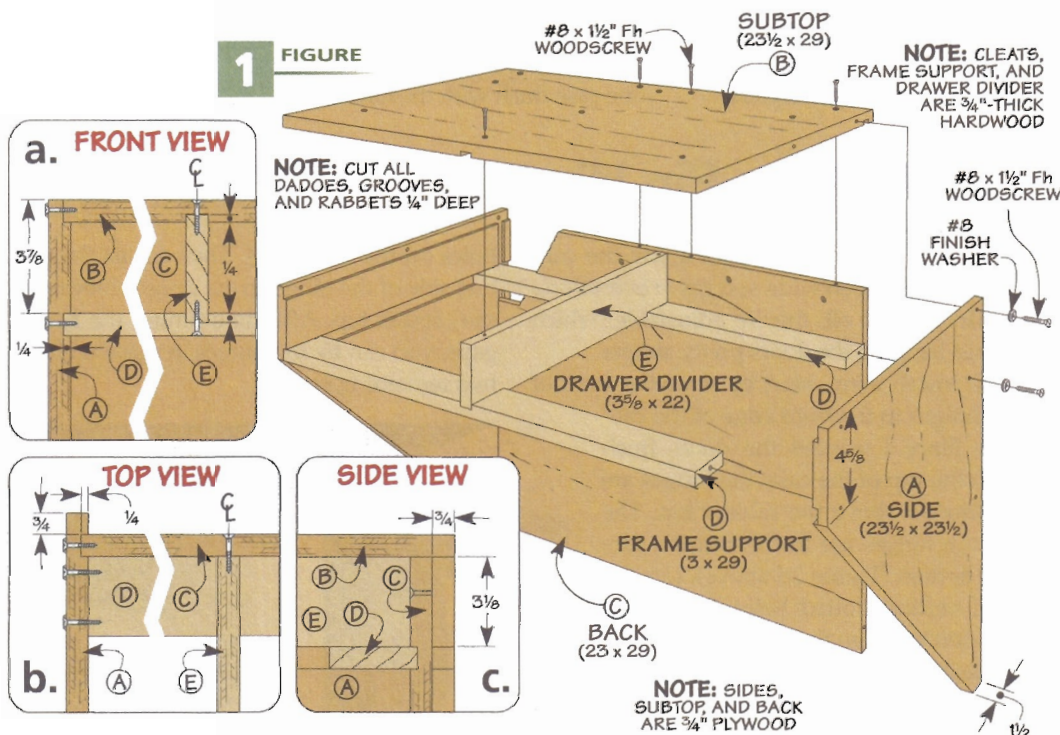

With the main joinery taken care of, it's just a matter of cutting the remaining parts to size and assembling them. There's just one thing to note. When cutting the frame supports, there's a centered dado in each one to hold the drawer divider, as in Figures 1b and 1c.

That takes care of the frame of the work table. All that's left is to add the top and a pair of drawers. Let's start with the top.

The Top. To work as a writing surface, the top needs to be flat and smooth. And plywood just isn't smooth enough. So I made a top consisting of a double-layered sandwich (Figure 2). The top layer of $\frac{1}{4}$ " hardboard makes a smooth, durable surface. This is glued to a plywood layer to add strength. Then, the top is finished off with some mitered hardwood edging. Once the top is complete, you can screw it to the frame.

Add the Drawers. To add some storage to the work table, I built a pair of drawers that fit underneath the top. The drawers are constructed the same as the drawers in the tool cabinet shown on page 19, only larger. So you can find all the details you need there.

You'll need to add aluminum channel drawer guides to the frame. These guides are screwed to the frame sides and the drawer divider, as shown in Figure 2. Besides being larger, there's one

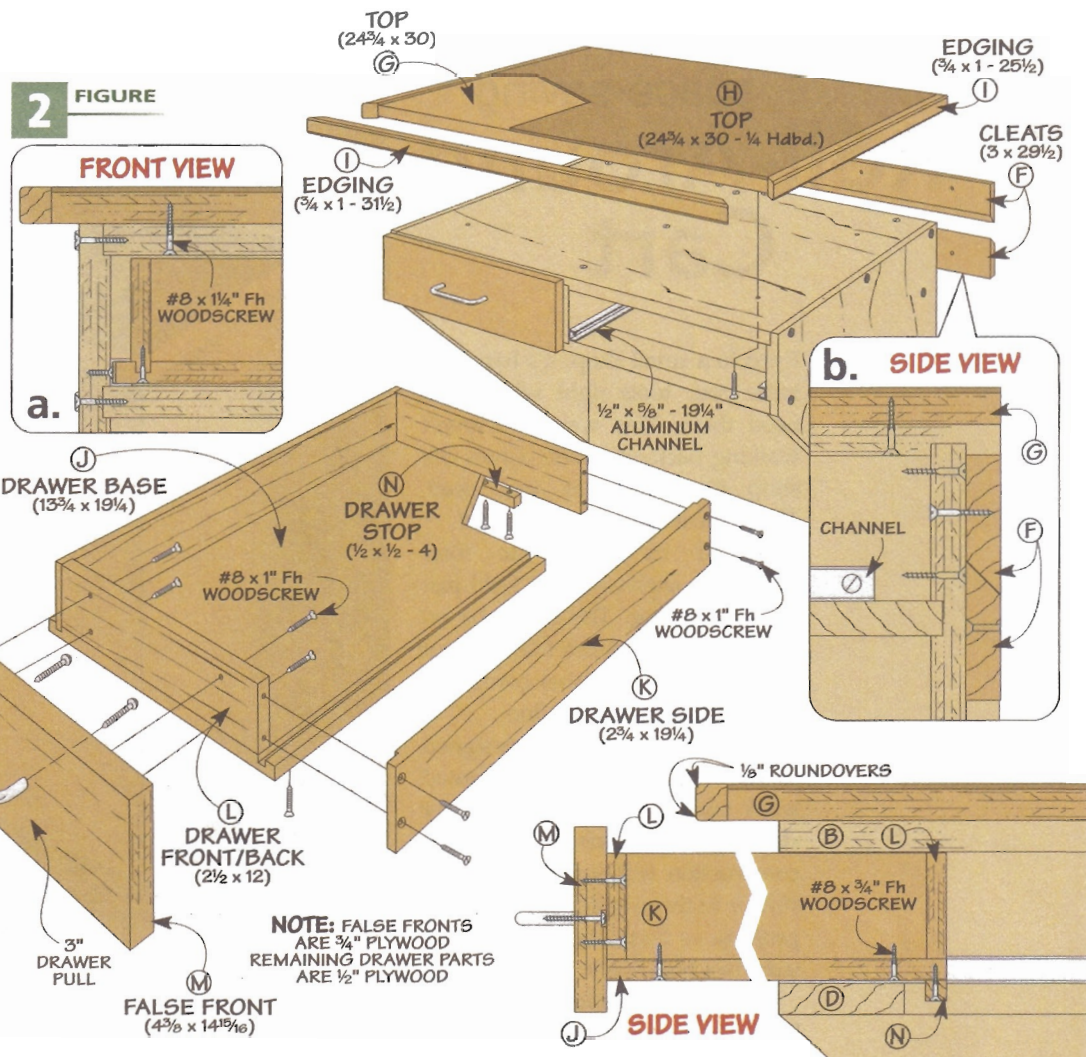

other difference to point out about the drawers. After the drawers were installed, I screwed a stop to the back edge of each drawer bottom to prevent the drawers from being accidentally pulled all the way out of the case.

Mounting the Table. I mounted the unit so the table top would be 36" off the floor. This sets it at a per-

fect height for sliding the roll-around cart, shown on the next page, underneath it. It's also a comfortable height for pulling up a stool and doing some sketching. When attaching the beveled cleat to back of the frame, you'll have to remove the drawers first. And make sure the other cleat is screwed to wall studs.

Cutting Diagonal Panels

One of the challenges I faced in building the wall-mounted work table is making the angled sides. It can be difficult, to cut pieces like these on the table saw. But with a circular saw and a simple edge guide, the process is easy.

The key to this technique is the cutting guide you can see in the drawings at right. To make the guide, start by cut-

ting a wide base made from $\frac{1}{4}$ " hardboard. Next, attach a plywood fence. This fence guides the saw as you make the cut. To complete the guide, make a pass with the saw to trim a reference edge. You can support the workpiece by setting it on a sheet of foam insulation.

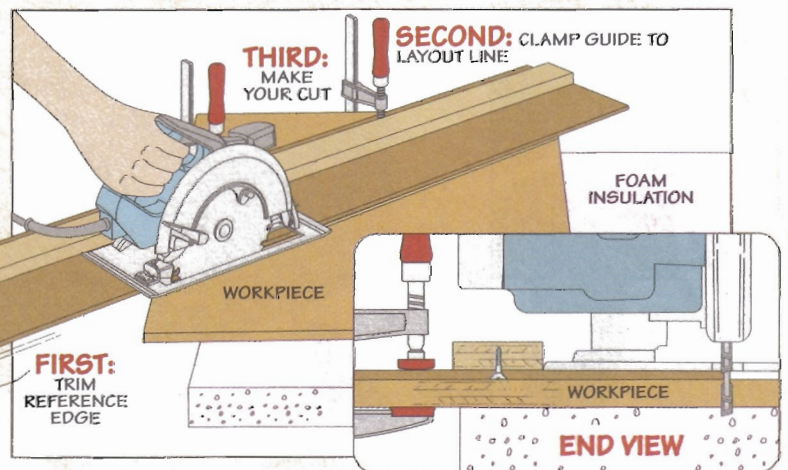

space-saving Roll-Around Cart

Even in a small shop, it's handy to have your tools right where you need them. This way, you aren't walking back and forth across the shop fetching what you need. That's the reason I built this cart.

Behind its doors are four, adjustable shelves that'll hold just about anything. The cart rolls on locking swivel casters that make it easy to roll over power cords and any debris lying on the floor.

The roll-around cart is designed to tuck under the wall-mounted work table shown on page 20 for storage. You'll even find that the construction techniques are pretty similar to those of the previous two projects, so there shouldn't be any surprises building it.

The Case. Building the cart begins by assembling the case. The first parts to make are the case sides. In the drawing below, you can see that most of the other parts in the case will tie into these pieces.



At the table saw, I cut a rabbet on each end of the sides. The rabbet is sized to hold the bottom and a pair of braces at the top. Next, I cut a groove near the back edge to hold the case back and the top braces. The last step on the

sides is to drill holes for shelf pins that will be used to support the shelves that are added later.

The next pieces to make are the case bottom and the top braces. The joinery on these parts is pretty

1 FIGURE

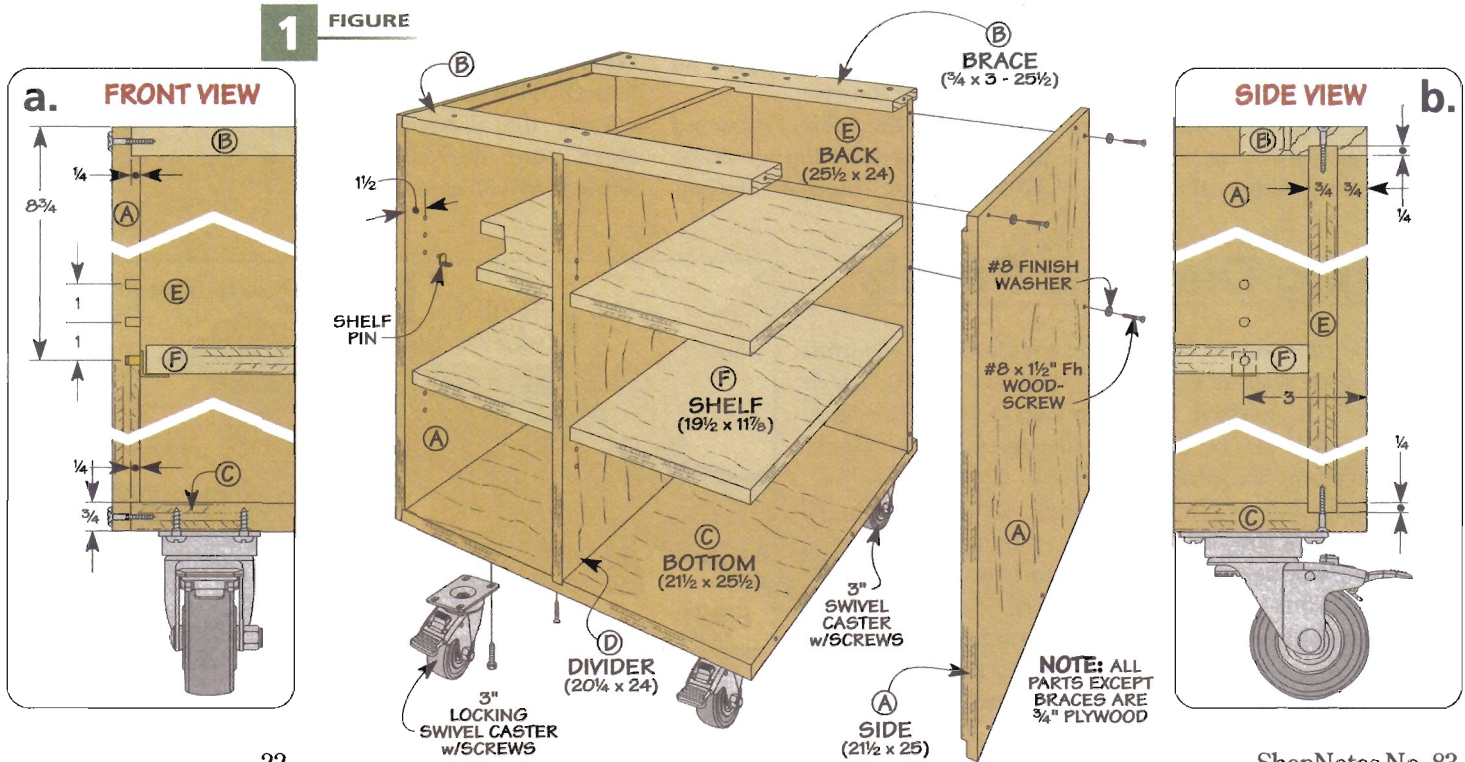

straightforward and can be done in two steps. The first step, is to cut a centered dado in the bottom and both braces. This dado will hold a divider that will be added later.

The second joinery step is to cut a groove to hold a plywood back. Note: You only need to cut this groove in the bottom and the rear brace, as in detail 'b.' This takes care of the outer shell of the case.

All you need to do before assembling the case is to cut the middle divider and back to size. The case is held together with glue and screws. Like the other projects, the exposed screws on the sides also have finish washers for a cleaner look.

Shelves and Casters. After the case was glued up, I flipped the case over to attach the casters. Then I cut four shelves and fit them in place on shelf pins.

Layered Top. If you take a look at the drawing at right, you can see what's left to build. The work surface consists of a hardboard top glued to a plywood backing with mitered edging. The only detail to note has to do with the edging.

I screwed a handle to the front edging piece to make it easy to pull the cart around. I wanted to use the

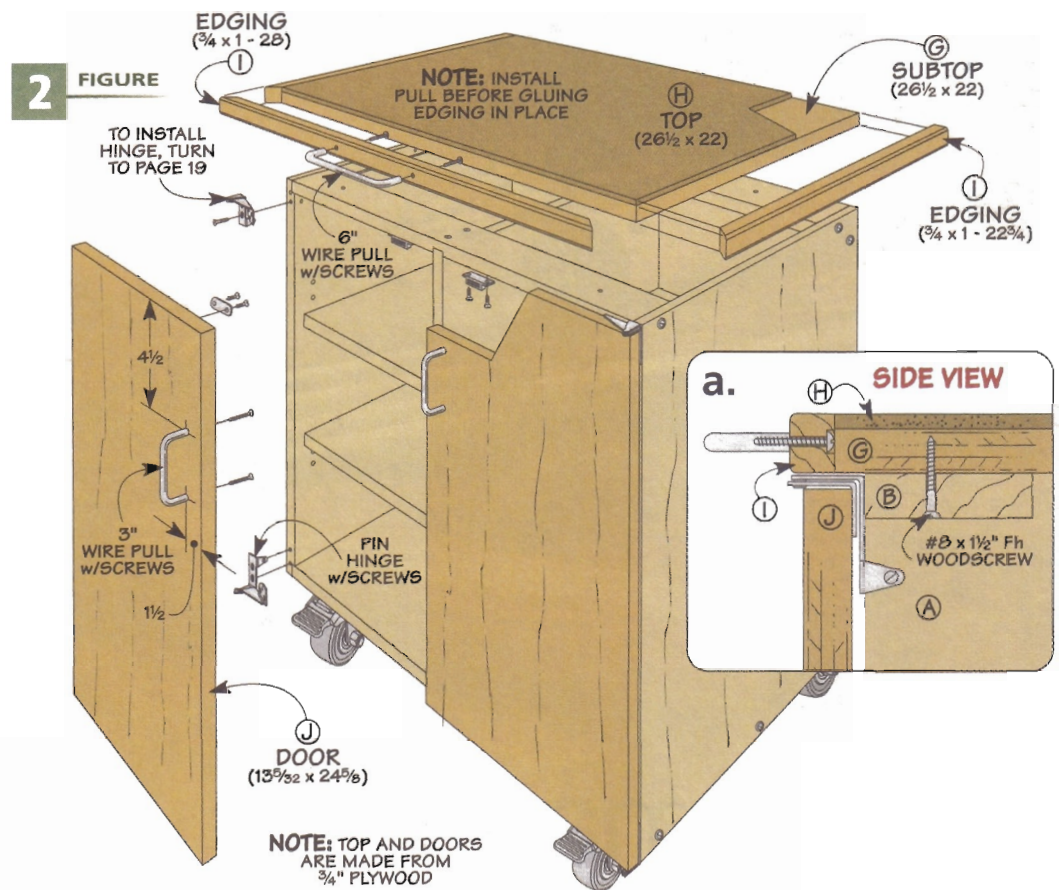

same type of pulls as on the doors. But because the pull attaches from the back, I had to install it before gluing the front edging in place, as shown in Figure 2a.

Basic Doors. At this point, all that remains is to add the doors.

And these couldn't be any easier. They're plywood panels that are attached with pin hinges ($\frac{3}{16}$ " gap between doors). These are the same hinges that were used on the tool cabinet. So you can turn to page 19 for installation tips.

Materials & Hardware

Wall Cabinet

A Sides (2)	10 x 36 - $\frac{3}{4}$ Ply.
B Top/Bottom/Divider (3)	10 x 29 - $\frac{3}{4}$ Ply.
C Center Panel (1)	9 x 26 $\frac{7}{8}$ - $\frac{3}{4}$ Ply.
D Drawer Divider (1)	10 x 7 $\frac{5}{8}$ - $\frac{3}{4}$ Ply.
E Back (1)	29 x 27 - $\frac{1}{4}$ Hdbd.
F Cleats (2)	$\frac{3}{4}$ x 3 - 28 $\frac{1}{2}$
G Shelves (4)	8 $\frac{1}{2}$ x 13 $\frac{5}{8}$ - $\frac{3}{4}$ Ply.
H Doors (2)	14 $\frac{29}{32}$ x 27 $\frac{13}{16}$ - $\frac{3}{4}$ Ply.
I Drawer Bases (6)	9 $\frac{3}{4}$ x 13 $\frac{3}{4}$ - $\frac{1}{2}$ Ply.
J Small Drawer Sides (8)	1 $\frac{3}{4}$ x 9 $\frac{3}{4}$ - $\frac{1}{2}$ Ply.
K Small Drawer Fr./Bk. (8)	1 $\frac{1}{2}$ x 12 - $\frac{1}{2}$ Ply.
L Small Drawer False Fr. (4)	2 x 14 $\frac{15}{16}$ - $\frac{3}{4}$ Ply.
M Large Drawer Sides (4)	2 $\frac{3}{4}$ x 9 $\frac{3}{4}$ - $\frac{1}{2}$ Ply.
N Large Drawer Fr./Bk. (4)	2 $\frac{1}{2}$ x 12 - $\frac{1}{2}$ Ply.
O Large Drawer False Fr. (2)	3 x 14 $\frac{15}{16}$ - $\frac{3}{4}$ Ply.
P Edging (1)	$\frac{3}{4}$ x $\frac{3}{4}$ - 30

- (16) #8 x 1 $\frac{1}{4}$ " Fh Woodscrews
- (12) #8 Finish Washers
- (12) $\frac{1}{2}$ " x $\frac{5}{8}$ " - 9" Alum. Channel ($\frac{1}{16}$ " thick)
- (36) #6 x $\frac{3}{8}$ " Fh Woodscrews
- (143) #8 x 1" Fh Woodscrews
- (16) $\frac{1}{4}$ " Shelf Pins
- (2 pr.) Pin Hinges (w/screws)
- (8) 3" Wire Pulls (w/screws)
- (2) Magnetic Catches (w/screws)

Work Table

A Sides (2)	23 $\frac{1}{2}$ x 23 $\frac{1}{2}$ - $\frac{3}{4}$ Ply.
B Subtop (1)	23 $\frac{1}{2}$ x 29 - $\frac{3}{4}$ Ply.
C Back (1)	23 x 29 - $\frac{3}{4}$ Ply.
D Frame Supports (2)	$\frac{3}{4}$ x 3 - 29
E Drawer Divider (1)	$\frac{3}{4}$ x 3 $\frac{5}{8}$ - 22
F Cleats (2)	$\frac{3}{4}$ x 3 - 28 $\frac{1}{2}$
G Top (1)	24 $\frac{3}{4}$ x 30 - $\frac{3}{4}$ Ply.
H Hardboard Top (1)	24 $\frac{3}{4}$ x 30 - $\frac{1}{4}$ Hdbd.
I Edging (1)	$\frac{3}{4}$ x 1 - 84 Rgh.
J Drawer Base (2)	13 $\frac{3}{4}$ x 19 $\frac{1}{4}$ - $\frac{1}{2}$ Ply.
K Drawer Sides (4)	2 $\frac{3}{4}$ x 19 $\frac{1}{4}$ - $\frac{1}{2}$ Ply.
L Drawer Front/Back (4)	2 $\frac{1}{2}$ x 12 - $\frac{1}{2}$ Ply.
M Drawer False Fr. (2)	4 $\frac{3}{8}$ x 14 $\frac{15}{16}$ - $\frac{3}{4}$ Ply.
N Drawer Stops (2)	$\frac{1}{2}$ x $\frac{1}{2}$ - 4

- (18) #8 x 1 $\frac{1}{4}$ " Fh Woodscrews
- (14) #8 Finish Washers
- (59) #8 x 1" Fh Woodscrews
- (2) 3" Wire Pulls (w/screws)
- (4) $\frac{1}{2}$ " x $\frac{5}{8}$ " - 19 $\frac{1}{4}$ " Alum. Chan. ($\frac{1}{8}$ " thick)
- (12) #6 x $\frac{5}{8}$ " Fh Woodscrews

Roll-Around Cart

A Sides (2)	21 $\frac{1}{2}$ x 25 - $\frac{3}{4}$ Ply.
B Braces (2)	$\frac{3}{4}$ x 3 - 25 $\frac{1}{2}$
C Bottom (1)	25 $\frac{1}{4}$ x 21 $\frac{1}{2}$ - $\frac{3}{4}$ Ply.
D Divider (1)	20 $\frac{1}{4}$ x 24 - $\frac{3}{4}$ Ply.
E Back (1)	25 $\frac{1}{2}$ x 24 - $\frac{3}{4}$ Ply.
F Shelves (4)	19 $\frac{1}{2}$ x 11 $\frac{7}{8}$ - $\frac{3}{4}$ Ply.
G Subtop (1)	26 $\frac{1}{2}$ x 22 - $\frac{3}{4}$ Ply.
H Top (1)	26 $\frac{1}{2}$ x 22 - $\frac{1}{4}$ Hdbd.
I Edging (1)	$\frac{3}{4}$ x 1 - 76 Rgh.
J Doors (2)	13 $\frac{5}{32}$ x 24 $\frac{5}{8}$ - $\frac{3}{4}$ Ply.

- (18) #8 x 1 $\frac{1}{4}$ " Fh Woodscrews
- (14) #8 Finish Washers
- (20) #8 x 1" Fh Woodscrews
- (16) $\frac{1}{4}$ " Shelf Pins
- (2 pr.) Pin Hinges (w/screws)
- (2) 3" Swivel Casters (w/screws)
- (2) 3" Locking Casters (w/screws)
- (2) 3" Wire Pulls (w/screws)
- (1) 6" Wire Pull (w/screws)



shop-made Marking Knife

■ Accurate layout is the key to a successful project. And using a quality marking knife is a much more accurate way to mark a line than with a pencil. This is especially so when laying out joints that require near-perfect precision, such as dovetails

and tenons. The knife scores an extremely fine line, so unlike a thick pencil line, you know exactly where you need to cut.

I like the Japanese-style marking knife similar to the one you see pictured above. The blades have right or left beveled edges and steep angles, giving them a really sharp point — perfect for accuracy. However, one drawback is that they're

awkward to hold onto. To solve this problem, I made handles to give me better control when I use them.

If you take a look at the drawing below, you can see how the handle goes together. The blade is sandwiched between two wood blanks. The copper rings, or ferrules, on the ends not only help hold it together, but give the project the look of a traditional Japanese woodworking tool.

Set Screw. One nice feature is the set screw that holds the blade in the handle. It grips the blade firmly, yet allows you to easily change blades or remove the blade for sharpening. In addition, you can flip the blade around and slide the beveled end of the blade into the handle when you're not using the knife.

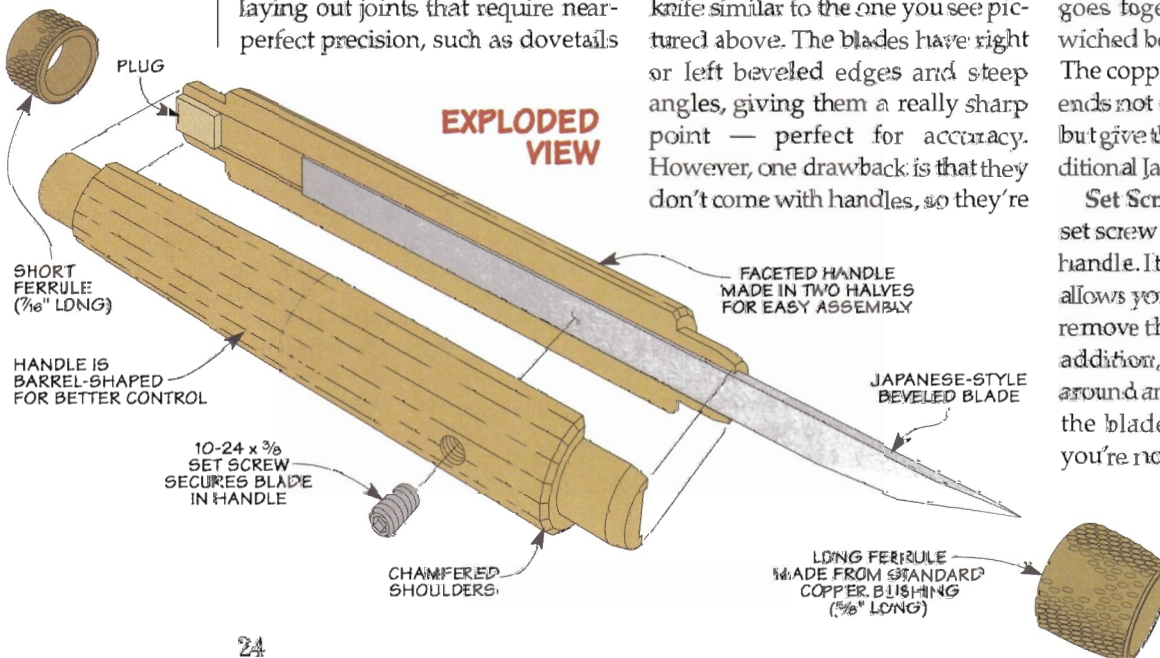

Getting Started. It may seem strange to start off with square blanks when the handle is going to end up round — but that’s exactly how this project begins. You’ll start with two rectangular blanks — one for each half of the handle, as you can see illustrated in Figure 1.

After cutting the blanks to size, you’re ready to rout a groove into each half to create a pocket for the blade (Figure 1a). When the grooves are done, hold the pieces together and slide the blade into the slot for a test fit. You want it to fit snugly, but not so tightly that you have to force the blade into the slot.

Once you’re satisfied with the fit, now is a good time to drill and tap a hole for the set screw in one of the rectangular blanks (Figure 1b). After the screw hole is drilled, you can glue the halves of the handle together, taking care not to get any glue in the groove.

Round the Edges. When the glue dried, I took the handle over to my router table and rounded the edges to create a circular body. The box at the bottom of the page shows how I did this. After that, I cut the square ends off the blank, as you can see in Figure 2, and plugged the hole in one end of the blank (End View).

That’s really all there is to shaping the handle. On the next page, a few finishing touches are added to dress it up and make it easier to hold.

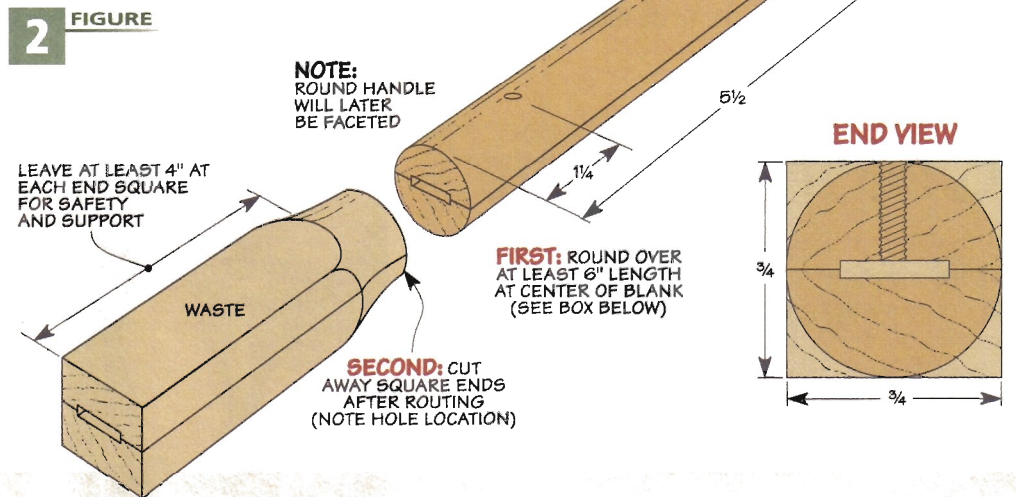
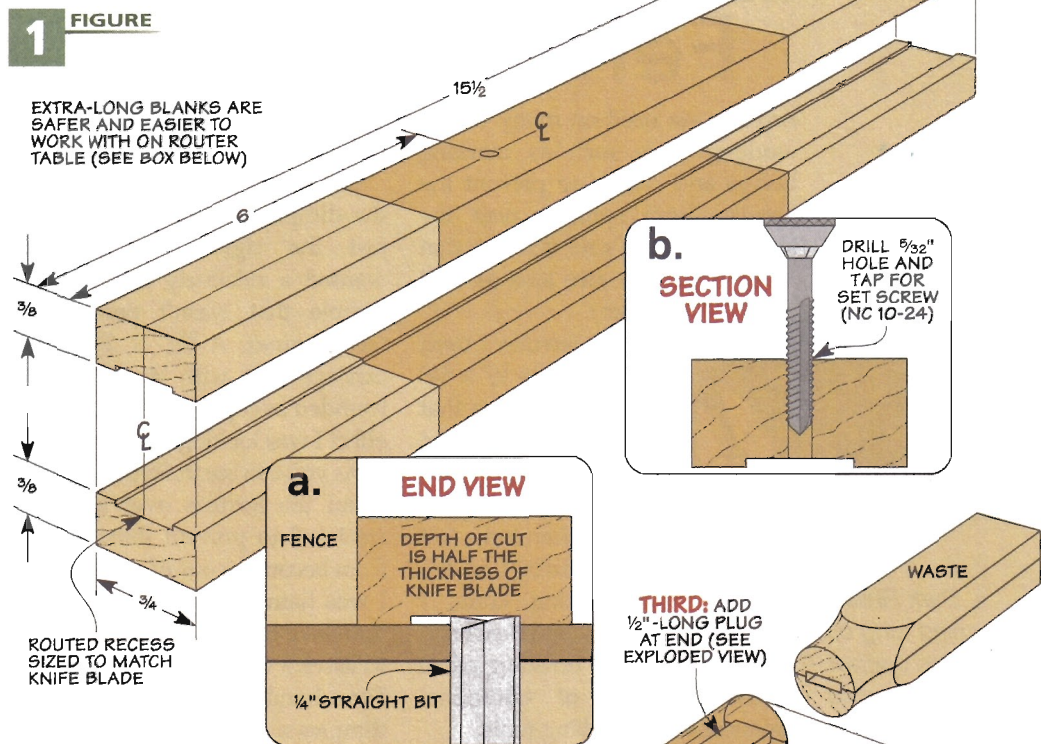

Make It Round

Sharp corners and square edges don’t make a comfortable knife handle. But turning the square blank into a smooth, round handle isn’t difficult at all.

As you can see in the drawing on the right, the rounded handle is formed in the middle of the long rectangular blank. By doing it this way, the square ends make the blank easier and safer to work with.

First, I also marked my starting and ending points on the blank. Then, set up a 3/8"-radius roundover bit and the router fence according to the inset drawing on the right. To rout the blank, slowly pivot the blank into the bit at the first mark and slide it to the second mark. Repeat this three more times, rotating the blank each time. Once the sharp corners are gone, you simply cut off the square ends to complete the handle.

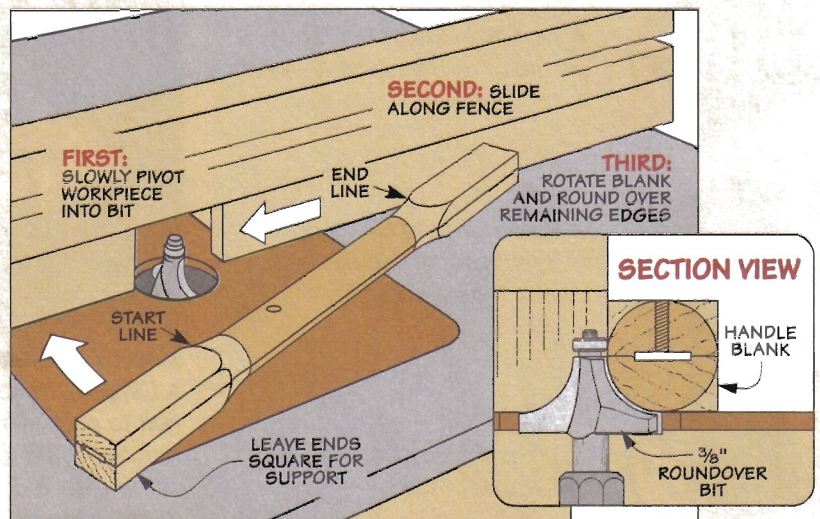

crafting the Ferrules

Ferrules are used on many wood-working tools such as marking knives and chisels to prevent the handles from splitting near the blade. But there's no denying that they can add a nice look as well (left photo).



▲ **Dark Finish.** Burning tung oil onto the copper ferrules results in this black finish.

The ferrules I used were simply $\frac{1}{2}$ " x $\frac{3}{8}$ " copper bushings that you can pick up at any hardware store (inset photo at right). But rather than have just plain copper fittings on the ends of my marking knife, I decided to "dimple" and then burn the ferrules with a finishing oil to match the look of traditional Japanese woodworking tools.

To start off, I cut the rear ferrule (Step 1). To do this, put the ferrule

over a wood dowel and cut it to size with a hacksaw.

Dimples. Next comes the dimpling process. For just the right look, I wanted a relatively large dimple that wasn't perfectly round. A $\frac{5}{16}$ " x 2" carriage bolt with its tip rounded over provided the effect I was looking for.

As you can see in Step 2, I slid the ferrules over a steel rod to prevent them from becoming out-of-round while I was hammering the dimples in. You have to hit the bolt pretty hard to leave a dimple, so don't be shy. For a handcrafted look, punch the dimples randomly.

Fiery Finish. To complete the ferrules, I brushed on an oil finish

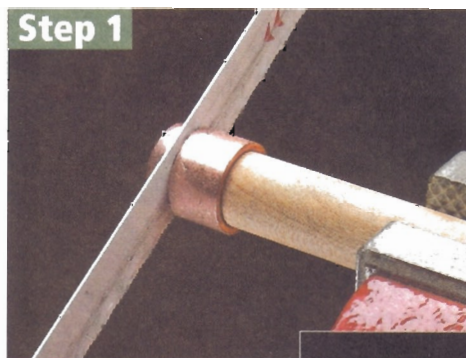

▲ **Copper Ferrules.** To cut the end ferrule to its final size, slide it onto a wood dowel and trim it with a hacksaw.



(Step 3) and then applied heat (Step 4). Different oils produce quite different looks, as you can see in the box at lower left.

While the ferrules cool down, you can start making the tenons for the ferrules on the handle (box at the bottom of the next page).

Recipes for Color Options

If the black finish pictured above is not to your liking, you can experiment with other finishing oils to find something you do like. In addition to the peanut oil finish, I used two other finishing oils (listed below), as well as no oil at all — I just scorched the plain copper bushing. And the longer you apply the heat, the darker and richer the final result becomes.



◀ **No Oil.** Heating the ferrules with no oil on them simply gives the copper an antique look.

◀ **Boiled Linseed Oil.** Firing this oil produces a medium-brown hue on the copper ferrule.

◀ **Peanut Oil.** Heating peanut oil gives the ferrules a golden-red appearance.



Step 2

▲ **Dimples.** Randomly tap the bolt to add "dimples" to the ferrules. I had to file the end of the steel rod a little to get the bushing on.

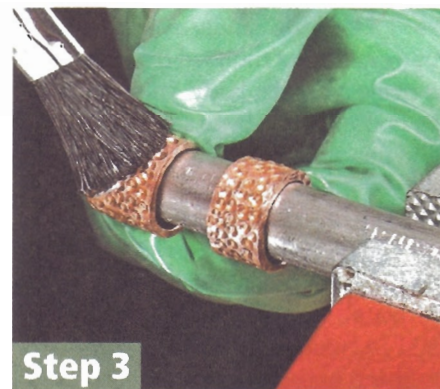

Step 3

▲ **Brushing on Oil.** Applying an oil to the ferrules is one step to get the look of traditional Japanese woodworking tools.



Step 4

▲ **Fire It Up.** Scorching the ferrules with a torch will discolor the finish and provide a hand-crafted finish.

planing the Facets

A perfectly round knife handle didn't feel quite right, so I added facets and a barrel shape to the handle. This gives you a better grip, plus the knife isn't as likely to roll off your workbench. And, best of all, because these facets are randomly planed into the handle, you can't really mess them up.

The photo on the right shows how the facets are made. First, draw a line around the center of the handle — this will be your reference point for both directions. Then, using a block plane, work from the centerline and shave the

handle. Start with light pressure and increase it as you near the end. You're looking for a tapered effect. After a couple of strokes, roll the handle and shave some more off. When you've finished one end, flip the handle over and taper the opposite end of the handle. Be sure, however, not to cut into the tenons on the ends of the handle.

Once that's done, take a chisel and create a chamfered shoulder around the tenons. And finally, install the ferrules on the tenons and spray the handle with several coats of lacquer. 🐿️



▲ *The Final Touch.* Starting from the center, taper the handle toward both ends using a block plane to create a faceted, barrel shape.

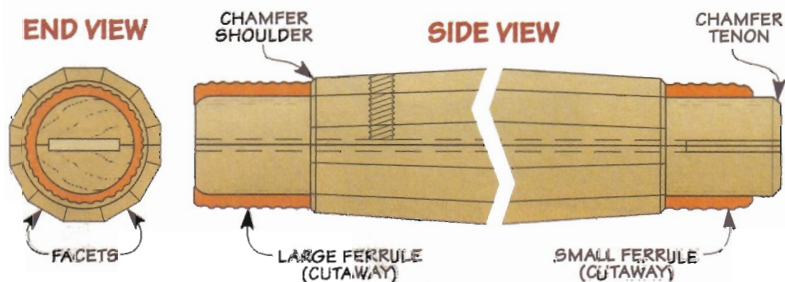

Routing Round Tenons

Cutting round tenons is easy on a router table, especially with the simple jig illustrated here.

To make the jig, all you need is a scrap of 2x4 and a piece of 1/8" hardboard. Start by ripping a 6"-long piece of 2x4 down to 1 3/4" wide. Turn it on edge, and then drill a 3/4" hole near one end of the block, centered on its width. After the hole is drilled, glue the hardboard onto the block as a base for the jig.

Next, install a 3/8" straight bit in the router table. Place the block against the router table fence and adjust the fence so the bit is centered on the end of the block.

Then raise the bit to 1/8" above the table and push the block from right to left until the bit cuts about halfway into the side of the 3/4" hole. Repeat this process, raising your router bit 1/8" each time, until

the height of the groove equals the length of the tenon you want, plus the 1/8" hardboard.

When the jig is ready, clamp it onto the fence. Leave enough of the bit showing in the hole to make a tenon the size to fit for the ferrules.

Turn the router on and slowly insert the knife handle into the hole until it comes to rest on the hardboard. Rotate the handle to complete the tenon. The bit not only will cut the tenon, but will leave a clean shoulder as well.

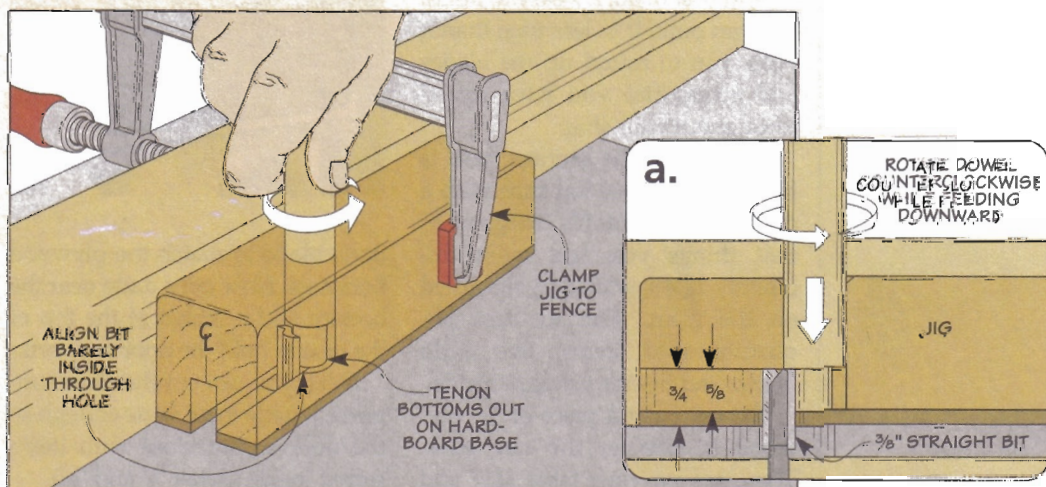

SHOP TIP

table saw Accessory Rack

With a place for everything, this rack keeps your table saw gear close at hand.

■ Without a doubt, my table saw is the most used tool in my shop. The only problem is keeping track of all the accessories that go along with it. They always end up scattered around the shop.

One way to clean up the clutter is the table saw accessory rack you see in the photo above. It's compact, hangs on the wall, and has specific spaces that keeps each item easily accessible when I need it.

And best of all, it's easy to build. You can build it in less time than it takes you to round up the blades and accessories you have stored throughout your shop.

The Case. The storage rack is simply an open-sided case with a door on the front. It's designed so that things you use more frequently, like saw blades, are stored on the front. And the less frequently used items, like dado blades and inserts, are kept inside.

To begin, cut a piece of $\frac{3}{4}$ " plywood to size for the case back. Then, set up your table saw and

dado blade to match the plywood thickness. Now cut a dado near the bottom and a rabbet at the top of the case to hold the door supports.

Next, you can cut the door supports. I made these wide enough so the door would close with items stored inside (detail 'a' and 'b').



◀ **Front Pockets.** Two hardboard pockets on the front of the door are sized to hold table saw blades.

Storage Pegs. After attaching the door supports to the case back, I drilled holes for some pegs that hold the dado blades and other accessories. To ensure that everything would stay put and not fall off, I angled the holes for the pegs at 10°. To help me do this, I made a simple drilling guide, like you see in the box on the next page.

Finally, drill holes in one corner of each door support to hold steel pins for the door to pivot on. But don't drill the bottom hole all the way through (detail 'b'). That way the hinge pin won't fall out.

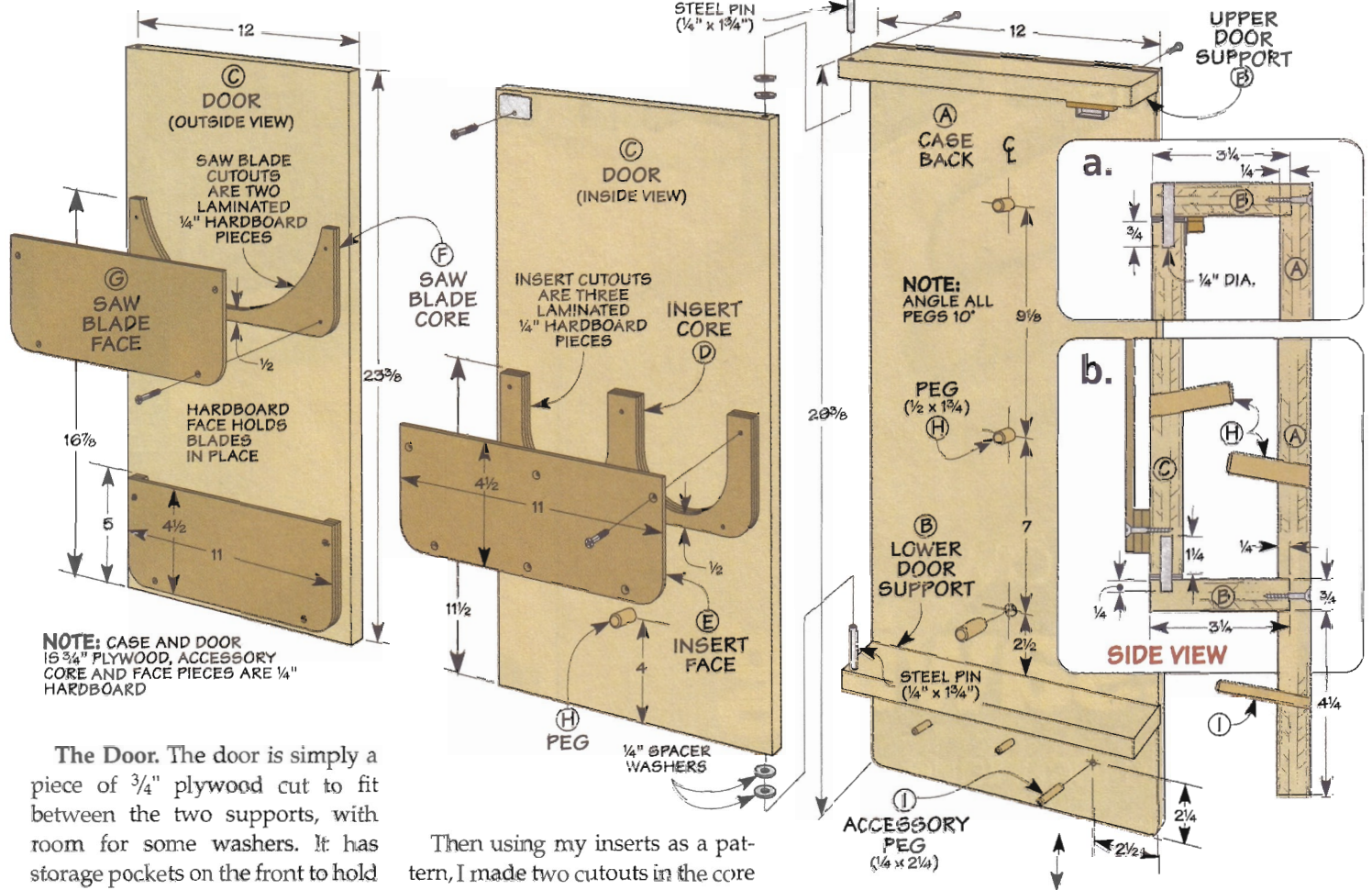

NOTE: CASE AND DOOR IS 3/4" PLYWOOD, ACCESSORY CORE AND FACE PIECES ARE 1/4" HARDBOARD

The Door. The door is simply a piece of 3/4" plywood cut to fit between the two supports, with room for some washers. It has storage pockets on the front to hold your blades and another set on the back for table saw inserts (see photo on opposite page).

Insert Pockets. The pockets are created by layering pieces of hardboard together. So to make the pockets on the inside of the door, I first made a core by laminating three hardboard pieces together.

Then using my inserts as a pattern, I made two cutouts in the core piece of hardboard 1/4" larger than the inserts. A hardboard face screwed to the front holds the inserts securely in place.

I used the angled drilling guide I made earlier to add a single peg beneath the insert pocket for storing my blade stiffener. But you can add as many pegs as you like.

Blade Pockets. You'll want to add two more pockets to the front of the door to hold saw blades (see lower photo opposite page). Since the saw blades are thinner, you'll only need to glue two pieces of hardboard together for the core. Again, use a saw blade as a pattern and allow 1/4" extra around the blade.

Hang the Door. At this point, you're ready to mount the door. To do this, you'll need to drill two holes in the door to hold a pair of steel pivot pins. A simple drilling guide will help you locate and align the holes (see box at left).

Then it's a matter of mounting the door using the pins and a couple of washers so it can swing freely (see photo at right). An easy way to do this is to insert the bottom pin first, position the door, and then slip the top pin in place.

Now all that's left is to add a door catch to hold the door closed. After mounting the rack to the wall, you're ready to fill it with your blades and accessories.

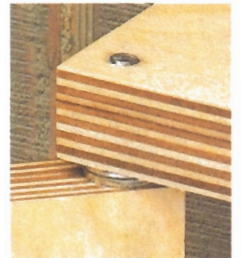

▲ **Pivot Pins.** A steel pin is used to mount the door. Two washers spaced between the door and the support allow the door to swing freely.

Drilling Guides

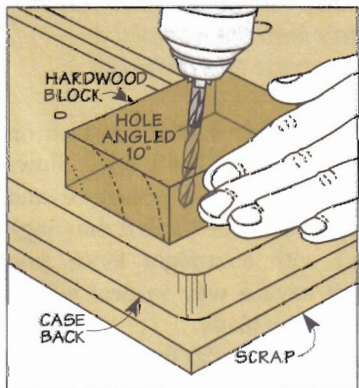

▲ **Angled Holes.** A simple block with a hole drilled through it at 10° makes it easy to drill the holes needed for the pegs.

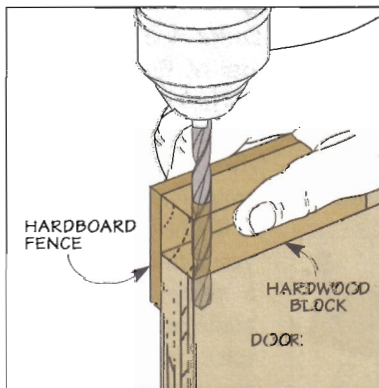

▲ **Straight Holes.** This block quickly locates the hole and guides the drill bit at 90° for drilling the holes to hold the steel door pins.

HANDS-ON Technique

band saw **Resawing**

A simple technique is all it takes to quickly turn thick boards into thin ones.

■ What do you do when you need thin wood for a project and don't want to pay an arm and a leg for it? One of the best solutions I can think of is to take some thick stock over to the band saw for resawing. In short order, you can come away with accurately cut, thin boards and almost no waste. And the best part is the technique is quick, easy, and won't require any fancy equipment.

Getting Ready. My goal when resawing is a perfectly straight cut, both through the width of the board *and* along its length. You'll

find that proper setup of the band saw for resawing goes a long way toward making this happen.

The Blade. The best place to start is by installing the right blade on the band saw. For top-notch results, you'll want to use a blade that's a little wider than your usual "all-purpose" blade. A 1/2"-wide hook-tooth blade, like the one shown in the upper corner of the opposite page, is my first choice. The hook-tooth pattern makes the blade cut aggressively, while the width adds stiffness for a straighter cut.

Blade Drift. But you'll find that even a wide band saw blade won't always track straight in a resaw cut. This is called "blade drift" and is caused by the teeth on one side of the blade cutting



▲ **Complete Control.** A shop-made push block allows you to safely feed the workpiece through the end of the cut.

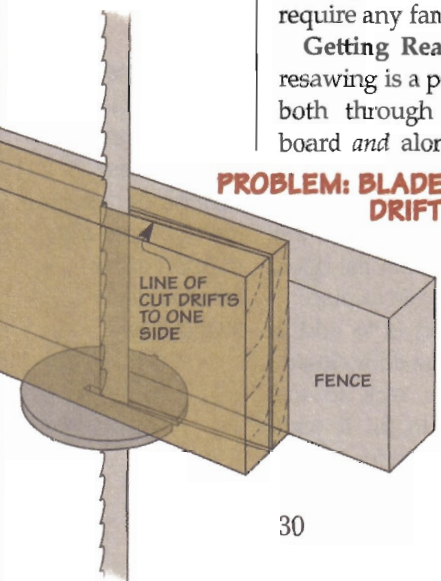

PROBLEM: BLADE DRIFT

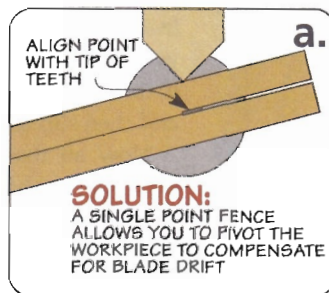

more aggressively than the teeth on the other side. The blade follows the path of least resistance and pulls to one side (far left drawing). And with a straight fence, you don't have a way to deal with a wandering blade.

Pivot Fence. So the second part to my setup is a simple pivot fence, like you see in the photo above and in the drawing on the following page. This type of fence allows you to easily overcome the problem of

blade drift. As you can see, the guiding edge of the fence is simply a sharp point. This gives you the freedom to simply steer the workpiece through the cut, adjusting for any drift as you go.

The only trick to installing a pivot fence is positioning it correctly on the band saw table. The distance from the teeth to the point of the fence equals the thickness of the workpiece. And the guide point should be aligned with the very tip of the teeth on the blade.

The Stock. With the pivot fence firmly clamped to the band saw table, all you need to do is prepare your stock and you're ready to cut.

I always make certain that the "guide" face of the stock is smooth and flat and the edges are square to the face. And before you can make the cut, you'll need a pencil line on the top edge of the workpiece to follow. I like to draw this line right where I want the blade to cut. This way you can simply guide the workpiece to "split" the line.

The Cut. At this point, making the cut is pretty straightforward. Start by feeding the stock into the blade directly on the line. The workpiece will contact the blade and the pivot fence simultaneously. To get a consistent thickness, you'll need to keep the workpiece snug

against the point of the fence. And as you can see in the main photo, one hand pushes while the other applies steady pressure against the fence.

Guiding the cut along the layout line is pretty easy. Just keep your eye on the top edge of the workpiece to see how the blade is tracking. If necessary, pivot the trailing end of the workpiece slightly to correct for any drift.

You'll find that a slow, steady feed will give you the smoothest cut. Listen to the saw for cues on the correct rate. You want to hear a light, rasping sound as you cut.

As I near the end, I pick up a simple, shop-made push block to feed the workpiece through the final few inches of the cut (inset photo and drawing at left). This lets me keep my focus on finishing the cut accurately. When the blade exits the board, you should see a straight cut from top to bottom and from end to end. But if the result isn't quite perfect, the problem is usually pretty easy to fix. Just check the box below.

▲ **The Right Blade.** For quick resaw cuts, I like to use a 1/2"-wide blade with three or four teeth per inch.

ACCESSORIES

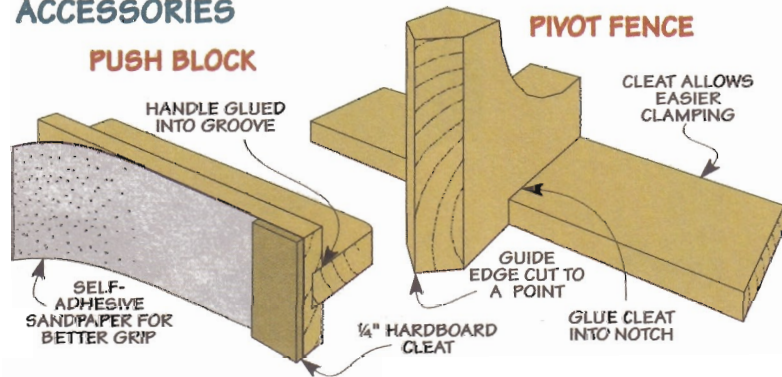

Problems and Solutions

There are a couple of common problems you might encounter when resawing, but both have easy fixes.

A Barrel Cut. When you end up with a cut that's rounded from top to bottom, you've experienced "barreling." There are two easy solutions for a barrel cut. First, make sure the blade is properly tensioned and increase the tension if necessary. Next, the upper guide assembly should be positioned as close to the workpiece as possible (detail 'a'). These steps will keep the blade from flexing in the cut.

An Angled Cut. Sometimes the cut is perfectly straight, but the workpiece tapers from top to bottom (lower far right drawing). This angled cut has a couple of

possible causes. The first could be that the blade or fence is not perpendicular to the table (detail 'b'). If this isn't the problem, take a look at the guide blocks. If not adjusted properly, they can force the blade out of alignment (detail 'c').

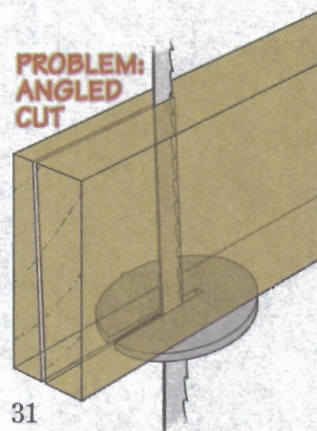
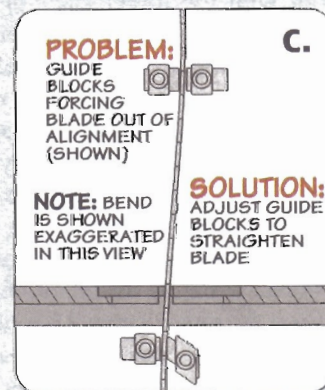
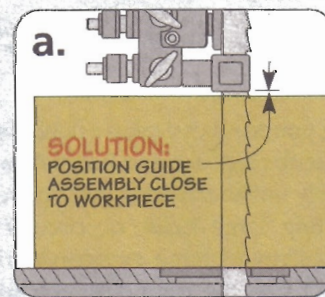
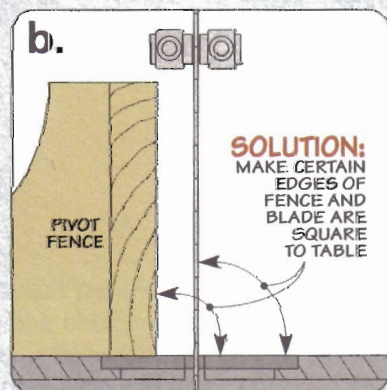

best-built
jigs &
fixtures

router Circle Jig

Perfect circles up to 4" in diameter —
and it's as easy as spinning a top.

■ The jig you see above takes a new spin (literally) on cutting circular recesses and holes. As a matter of fact, it's probably unlike anything you've ever seen before.

Cutting large holes or circular recesses usually involves buying large, expensive drill bits. And if you couldn't find the right size, you were simply out of luck. But with the router circle jig shown above, a plunge router, and a long, 1/2"-dia. bit, you'll be able to easily rout recesses and holes as small as 1/2", as large as 4", or anywhere in between. And what's really nice, building the jig only requires a few scraps of plywood, a handful of hardware, and a 6" lazy Susan.

So how well does it work? Extremely well, as a quick glance at the inset photo at right shows. The routing process is just a matter of establishing the depth of cut, plunging the bit into the workpiece, and then giving the jig a spin. Depending on the size of the recess or hole, you simply readjust the jig and repeat the process a few more times.



▲ *Perfect Results.* With a "corral" to securely hold the workpiece and jig, you can rout smooth, perfectly circular holes. Just clamp the workpiece down, set the jig in place, then simply plunge and spin.

Exploded View Details

OVERALL DIMENSIONS:
12"D x 12"W x 2 3/4"H (W/O ROUTER OR HOLDING ASSEMBLY)

Materials

A	Baseplate (1)	12 x 12 - 1/2 Ply.
B	Center Plate (1)	12 x 12 - 1/2 Ply.
C	Router Plate (1)	12 x 12 - 1/2 Ply.
D	Stop Block (1)	1 x 2 - 1/2 Ply.

Hardware

- (8) #6 x 3/8" Fh Woodscrews
- (7) 1/4" Washers
- (3) 1/4"-20 x 1 1/2" Carriage Bolts
- (3) 1"-Dia. Plastic Knobs
- (4) 1"-Dia. Furniture Glides
- (1) 6" Lazy Susan



▲ **Through Hole.** If all you need to do is cut completely through a workpiece, you can start at the final size and cut through in just a few passes.

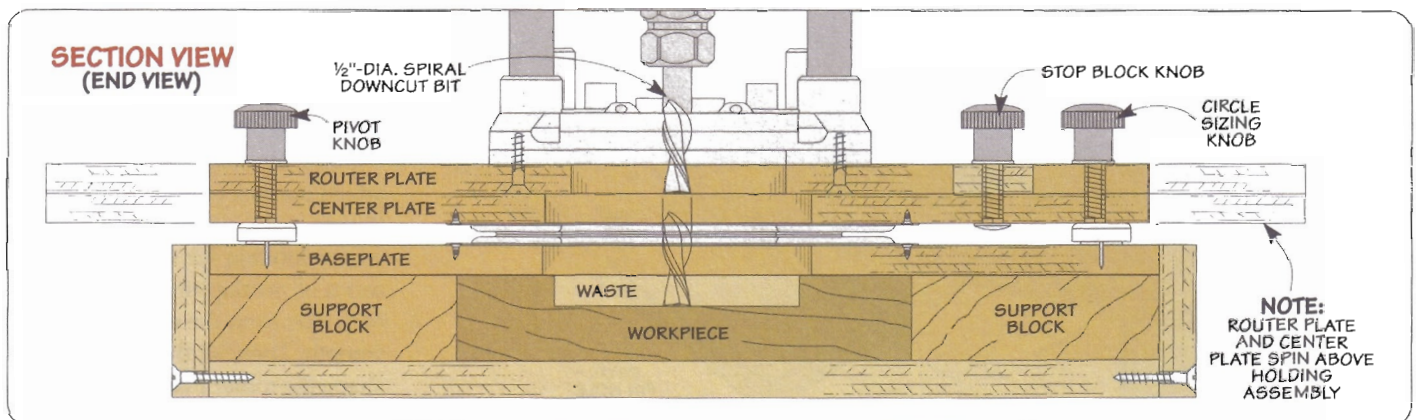
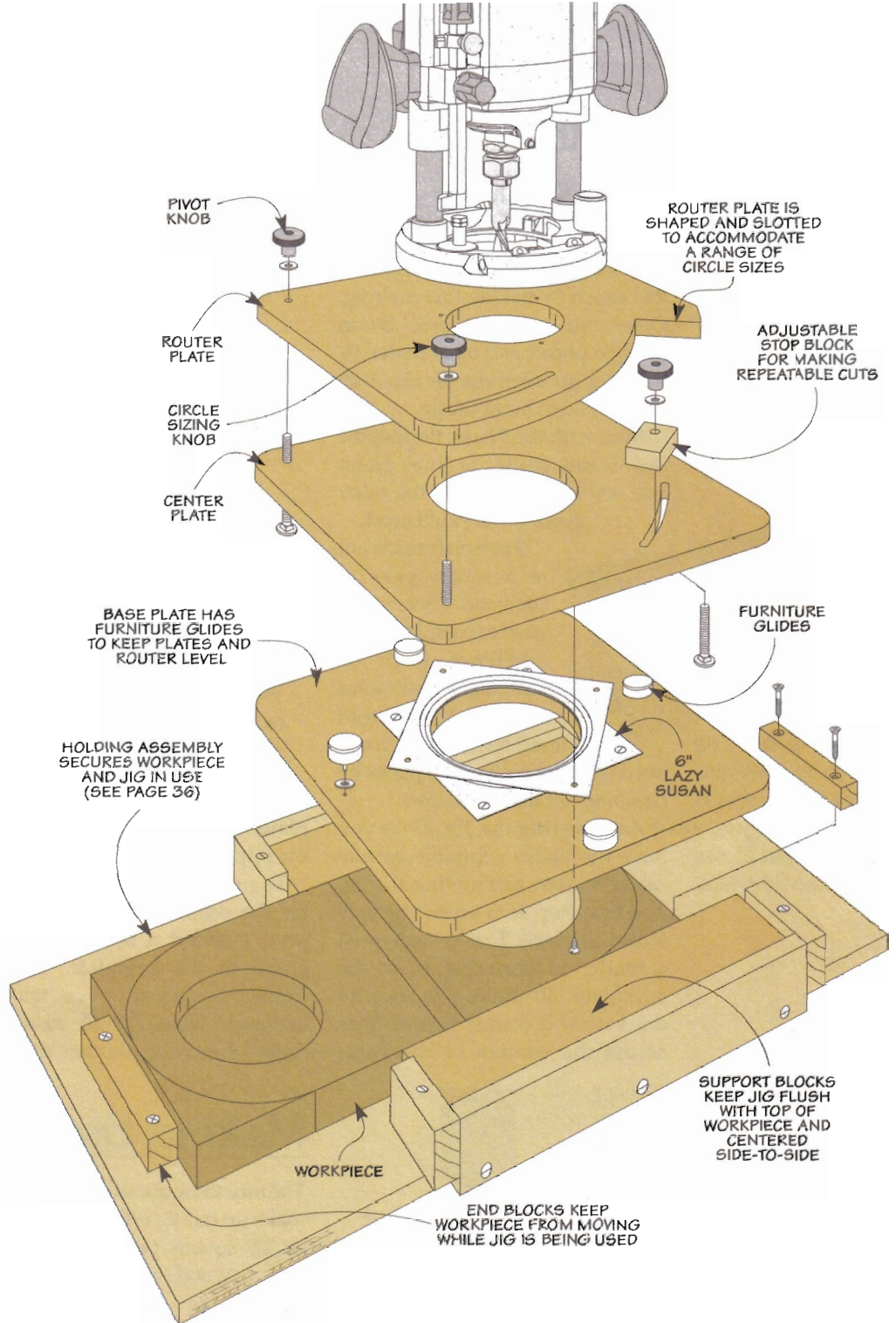

building the Base

As I mentioned, there really isn't that much to making this circle jig. Once you have the lazy Susan (margin photo) and other materials in hand, an afternoon is about all you'll need to build the jig.

Start with the Plates. Besides the lazy Susan, the set of three plates you see in Figure 1 are the other major parts you'll need.

Each plate starts out as a square piece of plywood. Then, you'll need to complete some additional work on each one to customize the plate. You can read more about what you'll need to do on each of the plates by checking out the box below.

Assembling the Jig. Once you have the plates complete, you're ready to start assembling the jig. The first step is to screw the lazy Susan in place. This is really just a matter of centering it on the baseplate. To make this easy to do, I drew a couple layout lines across the corners of the base-

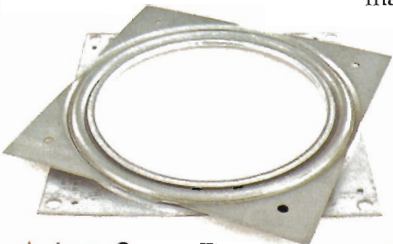

▲ **Lazy Susan.** The key to how well this circle jig works is an ordinary lazy Susan that allows the router to rotate.

1 FIGURE

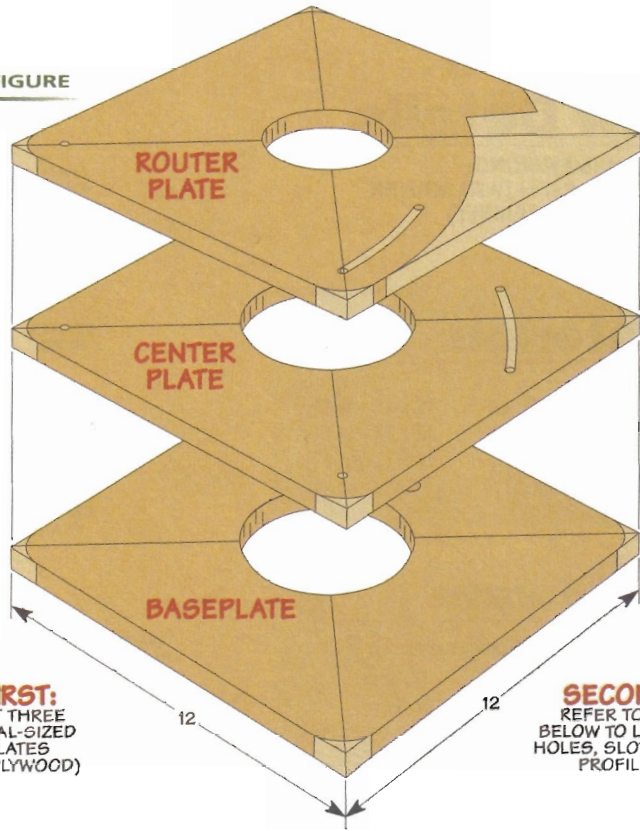

FIRST: CUT THREE EQUAL-SIZED PLATES (1/2"-PLYWOOD)

SECOND: REFER TO BOX BELOW TO LAY OUT HOLES, SLOTS, AND PROFILES

plate, as illustrated in Figure 2 on the opposite page.

To provide a little extra support for the center plate that goes on next, I added a set of furniture glides to the baseplate. They're simply tapped in place with a hammer. Note: You'll need to "snip" the nails shorter so they

don't extend through the bottom of the baseplate. And a washer under each glide helps ensure the top of the glide is even with the lazy Susan like you see in Figure 2a.

With the glides in place, you're ready to screw the center plate in place. Since you won't be able to install the carriage bolt used with

Making the Plates

The nice thing about the plates that make up this jig is they all start out as 12"-square pieces of 1/2" plywood, like you see in the drawings at right.

Then, to provide clearance for the bit, you'll need to cut a centered hole in each one. (I used a circle-cutter in my drill press to do this.)

Once you've completed the holes, you can turn your attention to the slots that make the jig adjustable. At left, you can see how I did this on my drill press with a plywood base and pivot pin.

Start by using carpet tape to attach the base so the distance from the pin to the bit matches the radius you're looking for. After drilling a series of overlapping holes to form each slot, sand the edges of the slot smooth. Then, all that's left to do is shape the router plate and round all the outside corners on each plate.

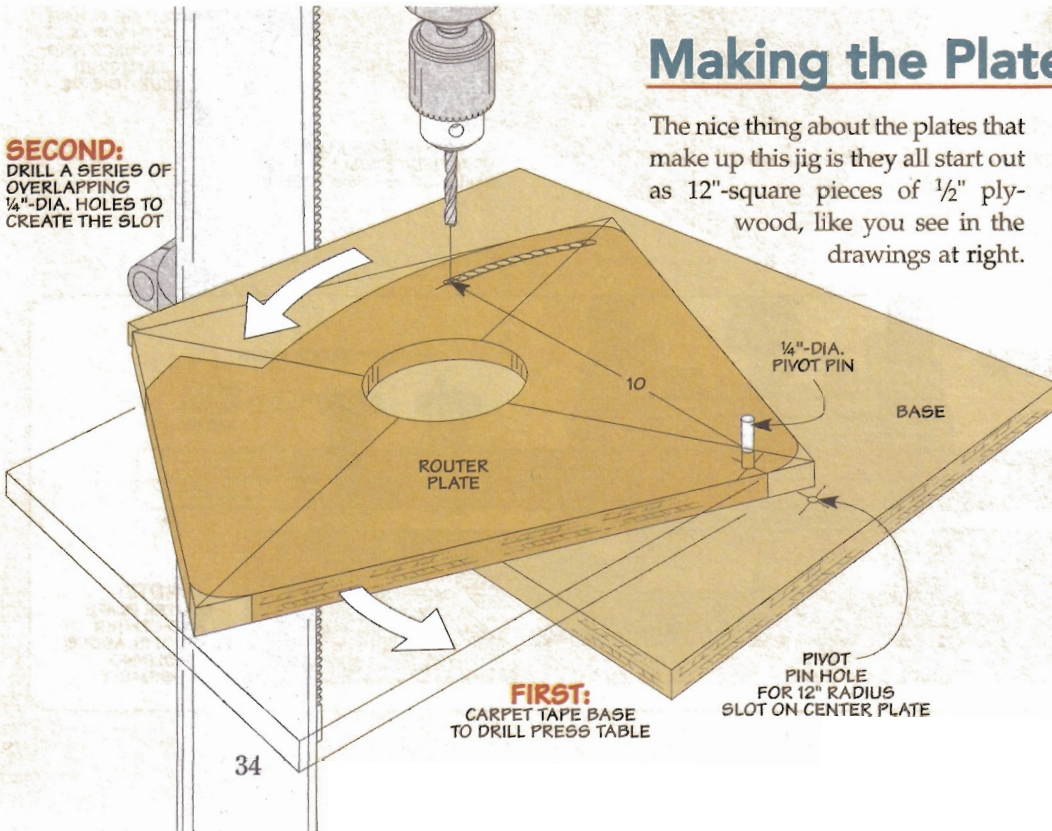

SECOND: DRILL A SERIES OF OVERLAPPING 1/4"-DIA. HOLES TO CREATE THE SLOT

FIRST: CARPET TAPE BASE TO DRILL PRESS TABLE

PIVOT PIN HOLE FOR 12" RADIUS SLOT ON CENTER PLATE

the stop block once the center plate is screwed down, make sure to slip the bolt in place first. Then just screw the center plate down using the access hole in the baseplate, as illustrated in Figure 2a.

Mounting the Router. The next step is to add your router to the router plate. This is just a matter of locating a set of mounting holes for your router to center the router bit in the opening and then screwing the router in place.

Finally, you can install the remaining two carriage bolts in the center plate, slip the router plate over the top of the bolts, and then lock everything down with a pair of knobs and a couple washers.

Adding the Stop Block.

At this point, you could start using the circle jig. But there's one last thing I added to make routing circles of identical size easy. And that's a stop block.

The stop block you see in Figure 2 is nothing more than a small plywood block with a hole drilled in it. Slipped over the carriage bolt you installed earlier, you can lock it in place with a knob and washer. As you swing the router

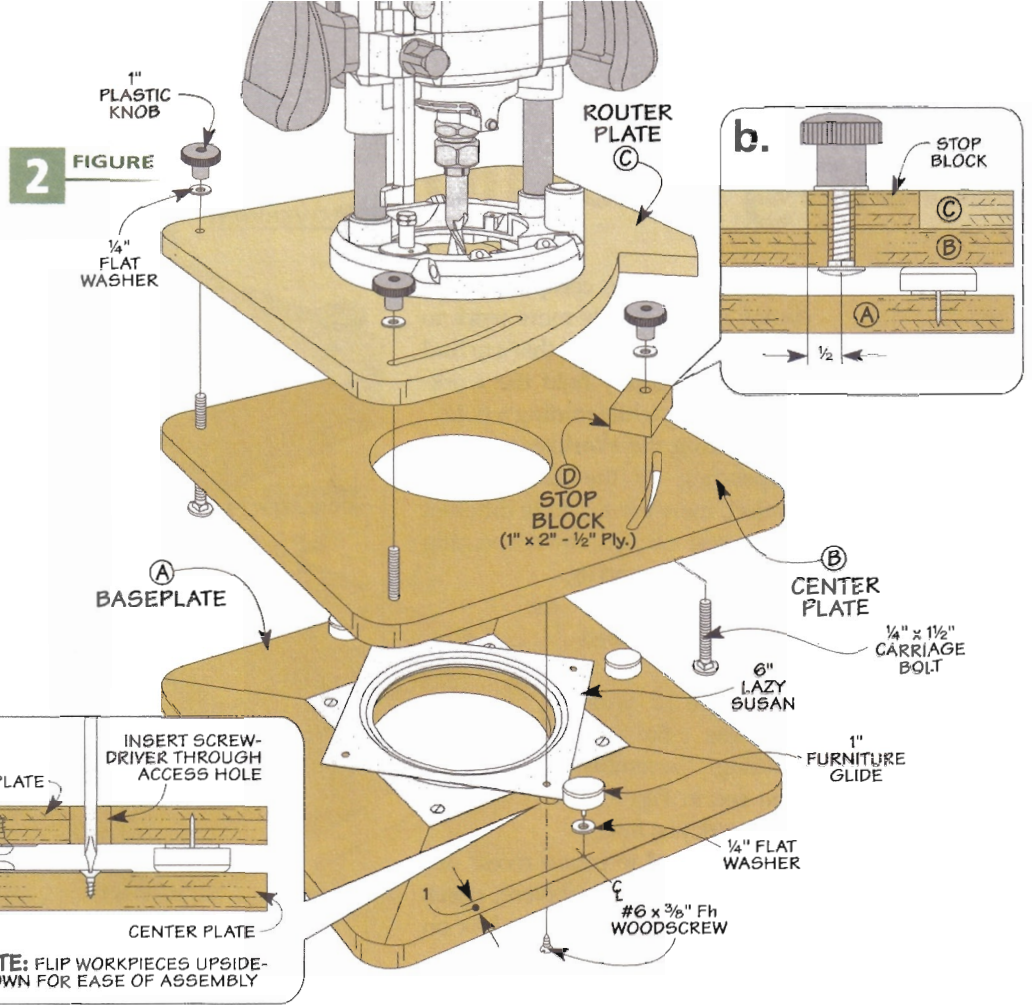
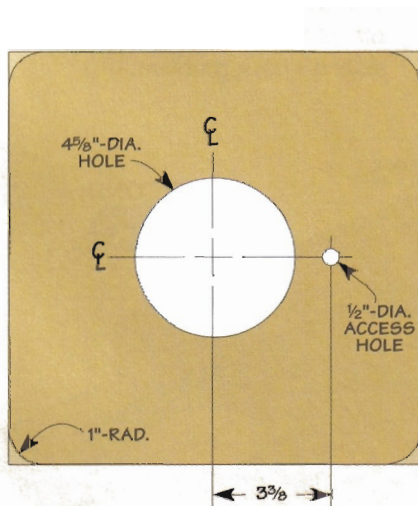
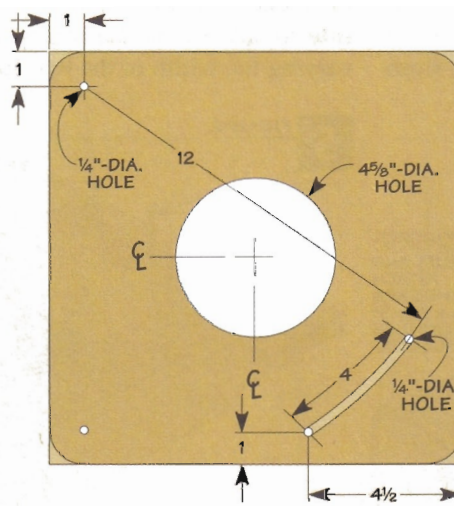

plate out to change the size of the circle you're routing, the router plate will stop against the block. This limits the size of the circle — making it easy to repeat that same size circle any number of times.

Once the stop block is in place, you're ready to start using the jig to rout a recess or hole. To do this, you'll need to secure the workpiece and jig while you work. You'll find more about this on the next page.



▲ **Baseplate.** After cutting a square baseplate, cut out the large center hole. Then you can drill an access hole for installing the screws for the lazy Susan and round the outside corners.



▲ **Center Plate.** The center plate starts out just like the baseplate with a centered hole. But instead of an access hole, cut a slot in one corner so you can add an adjustable stop block later.

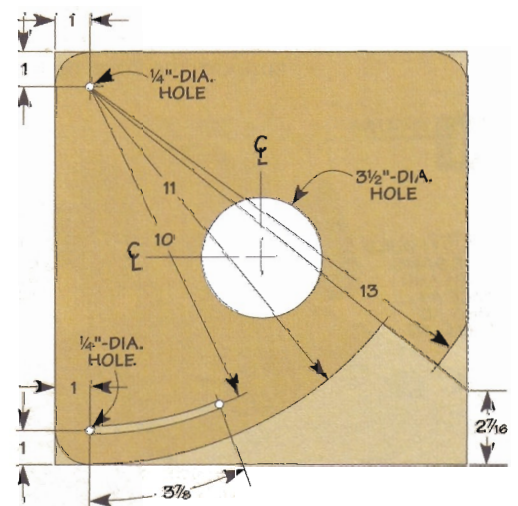

▲ **Router Plate.** After cutting an opening to match the base of your router, cut a slot near one corner to allow you to adjust the jig for circles of different sizes. Then complete the shaping of the plate.

securing the work & Using the Jig

Although the jig is complete at this point, there's a little more work to do before using it. And that's to find a way to securely hold the workpiece and jig while routing a hole.

Securing the Workpiece & Jig. Depending on the size of your project, there are a couple different ways you can go about securing the workpiece and jig.

In most cases, the recess or hole I need to make is in a workpiece 12" wide or less. So the holding assembly you see in Figure 3 will work just fine.

If you need to rout a recess or hole in a larger workpiece, check out the information in the box on the bottom of the opposite page.

How It Works. You get a good overview of how the holding assembly secures both the workpiece and jig by checking out Figure 3. And Figures 4 and 5 give you the details of building the assembly.

The holding assembly starts out as a long base and a pair of side supports to keep the jig from moving side to side. A set of end caps then traps the jig in place. To support the base of the jig flush

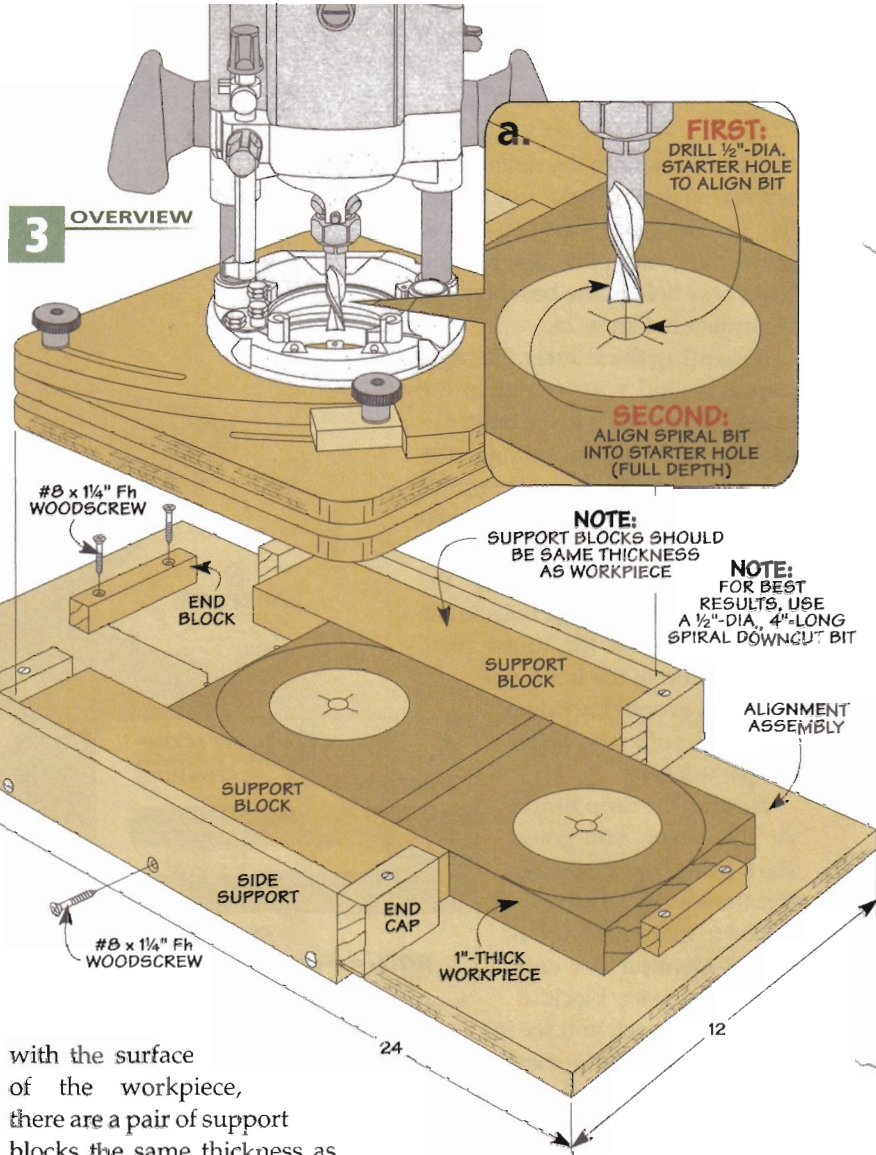

with the surface of the workpiece, there are a pair of support blocks the same thickness as the workpiece you'll be routing.

These support blocks do double duty. Besides supporting the jig, the blocks position the workpiece side to side under the router. By varying the width of the two sup-

port blocks, you can shift the position of the workpiece. This way, if you need to rout a recess or hole off-center, or a pair of holes side by side, it's not a problem.

4 FIGURE

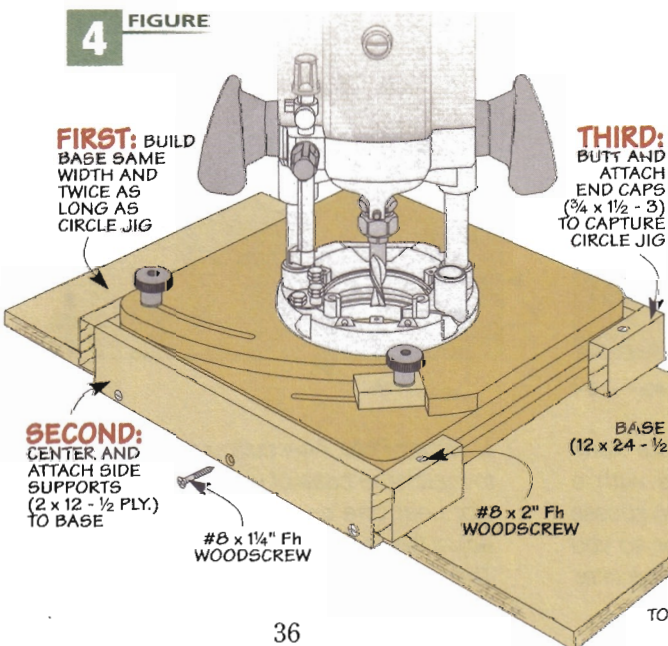

5 FIGURE

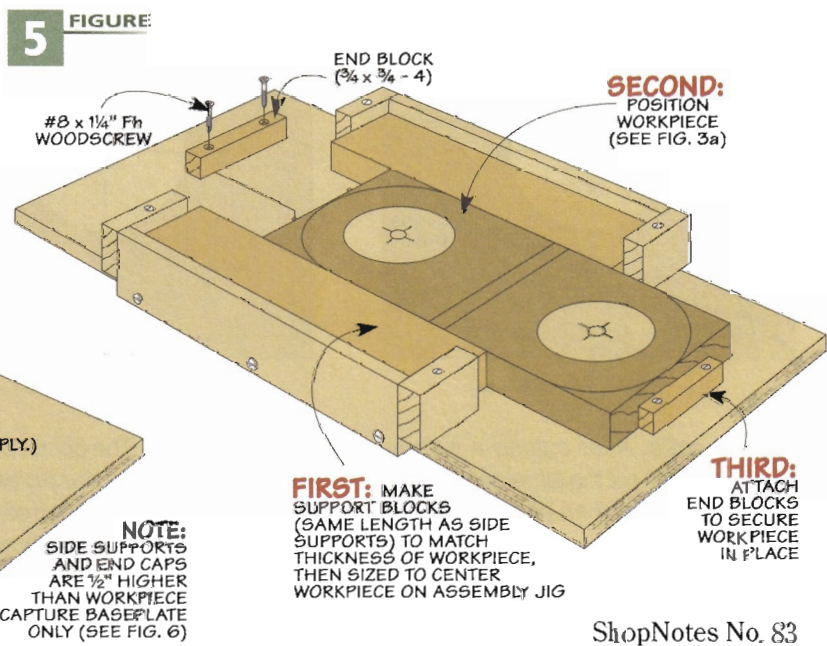

Finally, to keep the workpiece from moving end to end, there are a couple end blocks. Note: If you have a long workpiece, you can use a single end block to position the workpiece and then simply clamp it in place. The single end block allows you to rout multiple workpieces identically.

ROUTING THE RECESS

Once you have the holding assembly built, you're ready to rout a circular recess or hole — which is a simple process.

First, slip the workpiece in place and line it up under the bit. An easy way to do this is to drill a shallow 1/2"-dia starter hole and slip the router bit into the hole (Figure 3a). Note: You may have to adjust the width of the support blocks to "fine-tune" the position of the workpiece.

After setting the depth of cut, turn the router on and make an initial plunge cut (Figure 6a). Next, raise the bit, loosen the knob that holds the router plate in position, and then adjust the plate to increase the size of the hole by 1/4". Finally, retighten the knob, plunge the bit down, and spin the router clockwise to trim away the waste.

At this point, you simply repeat this process, nibbling away at the

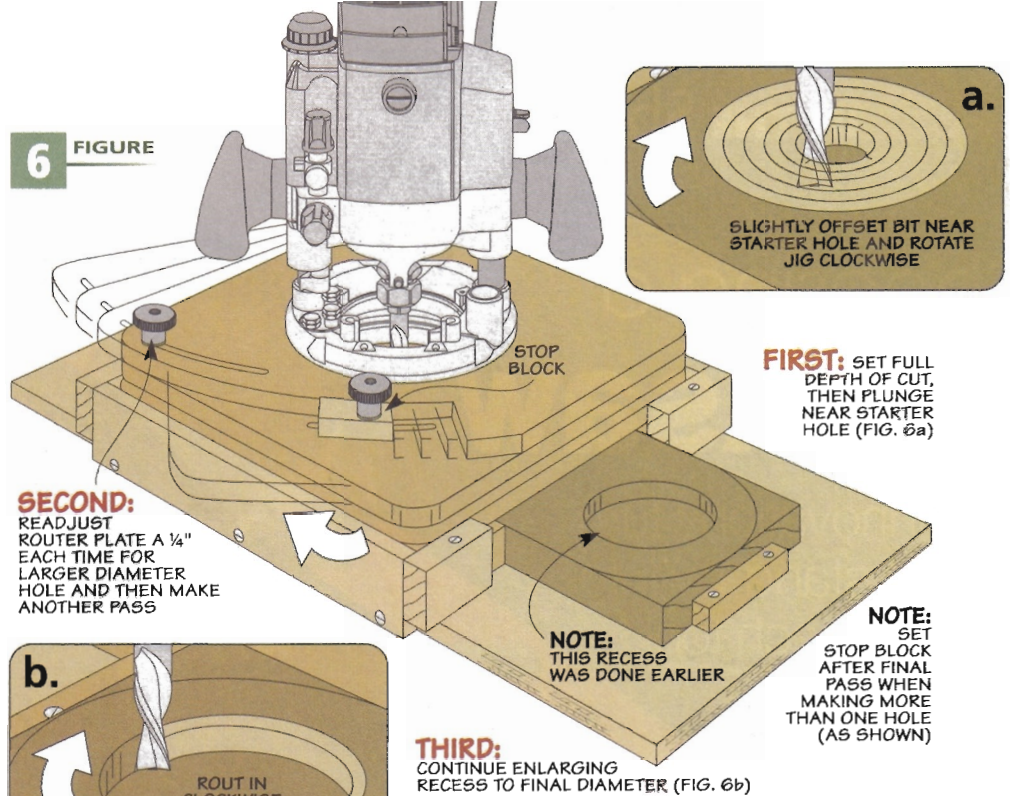

SECOND: READJUST ROUTER PLATE A 1/4" EACH TIME FOR LARGER DIAMETER HOLE AND THEN MAKE ANOTHER PASS

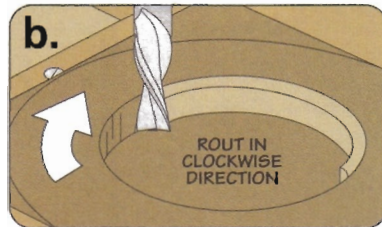

THIRD: CONTINUE ENLARGING RECESS TO FINAL DIAMETER (FIG. 6b)

waste until you "sneak up" on the size of the circle you want (Figure 6b). If you need to repeat this size on another workpiece, butt the stop block against the router plate and lock it in place. This way, the router plate will stop in exactly the same spot on the final pass each time.

Routing Through Holes. To rout completely through a workpiece, the procedure is just a little

different. You'll still locate the workpiece so it's centered under the bit to start with. But then instead of removing the waste by working from the center out, adjust the router plate to position the bit for the final size of the hole.

Next, set the bit to make a 1/4"-deep cut and rout a circular groove in the workpiece. Then just repeat this process, cutting a little deeper each time until you've routed completely through the workpiece. 

ShopNotes
GO ONLINE EXTRAS
To view a video on using this adjustable circle jig, go to: ShopNotes.com

Using the Circle Jig on Large Workpieces

You can use the circle jig to rout a recess or hole in a large workpiece just as easily. But instead of building a holding assembly for both the workpiece and jig, all you need is a frame to hold the jig in place, like the one shown in the drawing at right.

The frame is nothing more than a couple long side supports and a pair of 12"-long cross supports. After setting the jig in place so it's centered over the area you want to rout, clamp the supports around the jig.

The next step is to clamp the entire assembly to the workpiece. Once that's complete, the process of routing a recess or hole is the same as before.

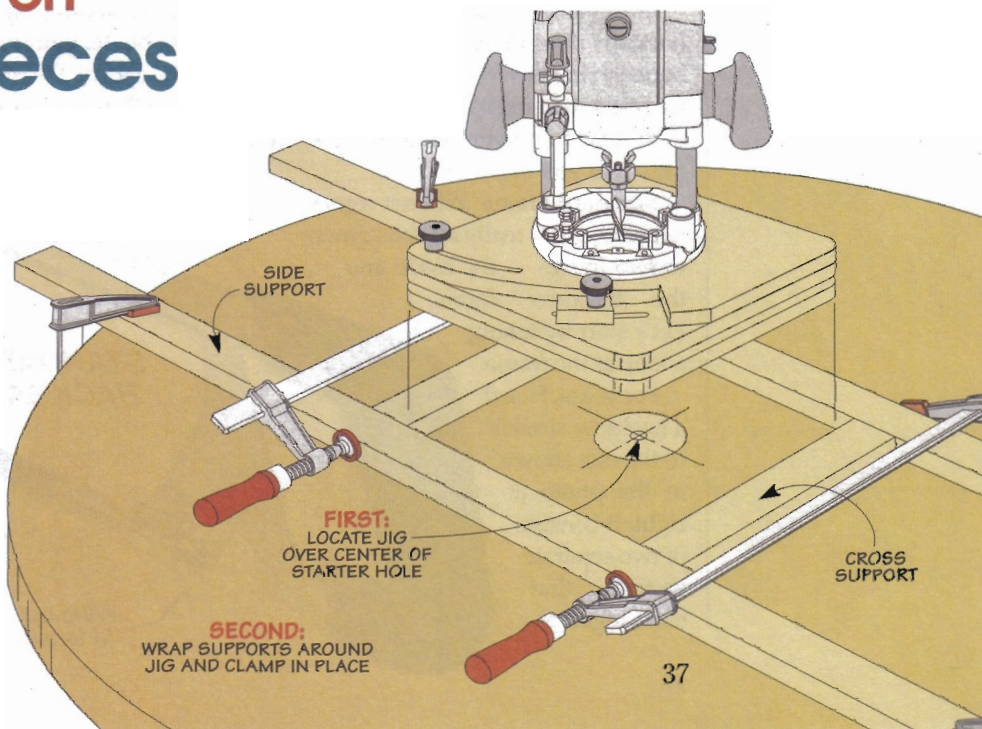

Choosing a Hacksaw

New innovations turn this old stand-by into a high-tech tool.

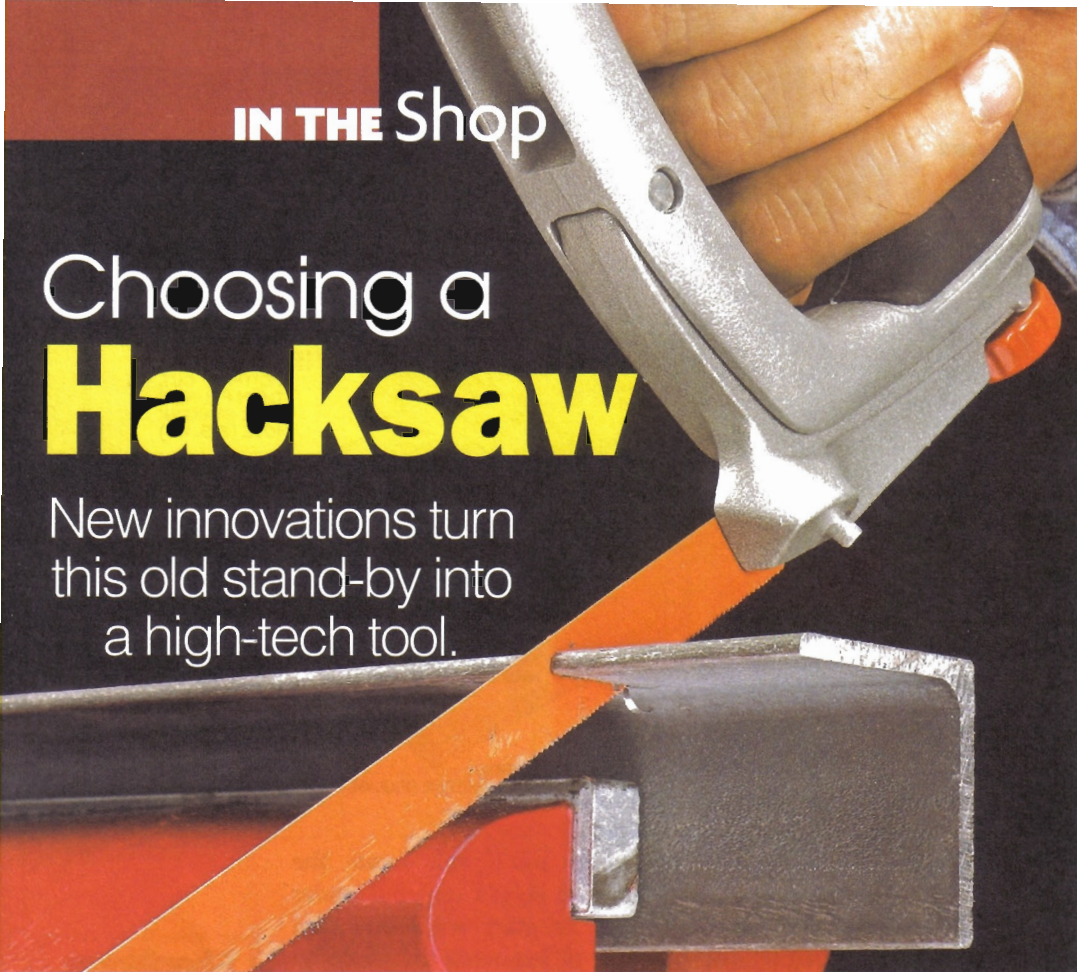

There are a lot of tools that I actually enjoy using. But to be honest a hacksaw isn't one of them. That's because no matter how smoothly things seem to be going when I'm using one, before long the blade binds right in the middle of the cut and the saw stops dead in its tracks — while my arm wants to keep moving.

But I've discovered that using a hacksaw doesn't have to be such a bone-jarring experience. The key is to select the right hacksaw. And that means knowing what to look for when you buy one.

Standard Frame. When it comes to hacksaws, it really all boils down to two things — the blade and the hacksaw frame. Let's start by taking a look at the frame.

For years, I used a hacksaw similar to the one shown in the photo at right. It consists of two separate sections that slide together

and lock to allow you to adjust the size of the frame to hold different lengths of hacksaw blades. But the disadvantage of this two-piece construction is that you end up with a frame that's not very rigid. So the blade tends to twist and bind as you make a cut.

Another weak point in the design of this type of hacksaw is the blade-tensioning system. To tighten the blade, you turn a wing nut at one end of the saw frame. But even with the wing nut tightened all the way down, you

can't always tension the blade enough to keep it from wandering and binding during a cut. This makes it difficult to keep the saw tracking along a straight line.

High-Tension Hacksaws. So, how do you solve these problems? The answer is a high-tension hacksaw, like the one shown on the opposite page. At first glance, it may not look like there's much difference between the two types of frames. But using a high-tension hacksaw is like driving a sports car.

Unlike ordinary hacksaws, a high-tension hacksaw has a solid frame. This rigid, one-piece construction prevents the blade from twisting and binding during the cut. But more importantly, these hacksaws allow you to apply a lot more tension to the blade (up to 30,000 psi). The extra tension keeps the blade cutting smoothly along a straight line.

Crank Up the Tension. Tensioning the blade on a high-tension hacksaw differs slightly from saw to saw, depending on the manufacturer. But most of them use some sort of lever-tightening system. You simply release a lever, turn a knob to increase the tension, and then flip the lever back into position to tension the blade (see detail photo on top of opposite page). It's a lot easier on your fingers than trying to tighten a wing nut.

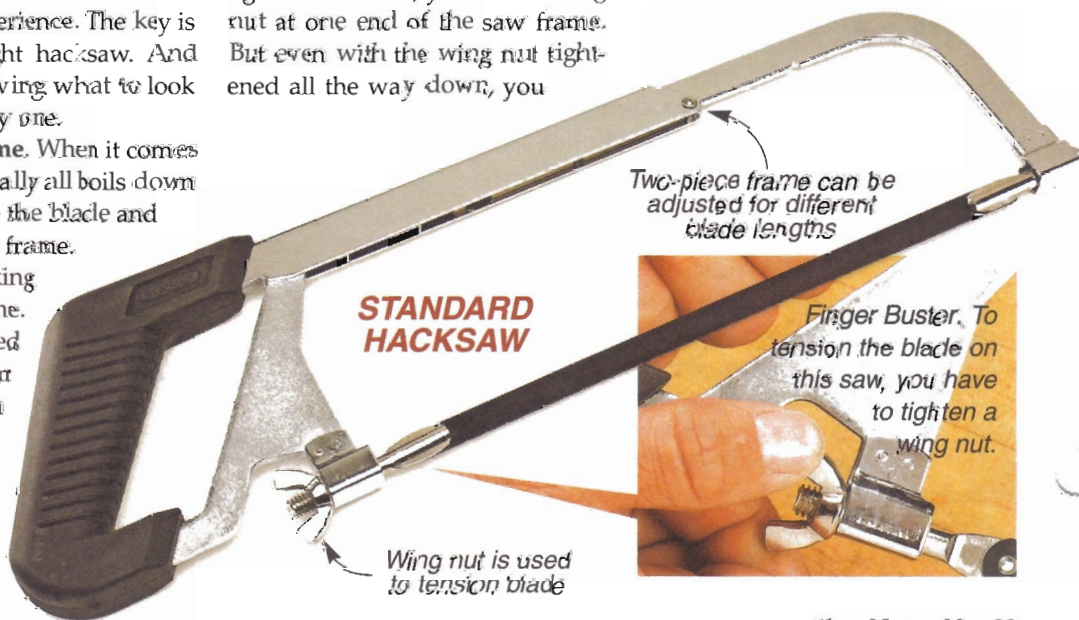



◀ **Lever Release.** To remove or install a blade, all you have to do is flip a quick-release lever.

Grip at front of saw allows for two-handed operation

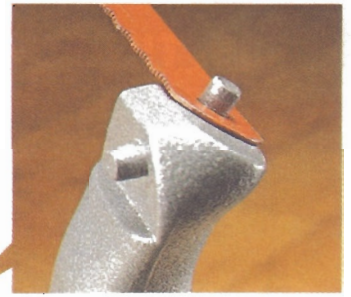

▲ **Blade Mount.** Each end of the blade fits over a fixed pin. A second pair of pins allows you to mount the blade at 90° or 45°



HIGH-TENSION HACKSAW

Ergonomic handle design

Tension adjusting knob

One-piece frame



◀ **Flush Cutting.** Mounting the blade at a 45° angle allows you to make flush cuts with ease.

And speaking of comfort, most of the high-tension hacksaws also have an ergonomic handle design that makes using them less of a strain on your hand and wrist. Several of these saws also incorporate a "horn" or a second grip at the front end of the saw for two-handed operation.

Flush Cutting. Another feature is that most of these hacksaws also

allow you to mount the blade at a 45° angle, as shown in the photo in the upper right. This gives you more clearance when making flush cuts against a wall or flat surface. The only downside is that these hacksaws are non-adjustable, so they only take 12" blades.

The best thing about high-tension hacksaws is that they don't really cost that much more

than a standard hacksaw. You can find them for around \$25 to \$30. (See page 51 for sources.) And after using one, I have to say they are worth every penny.

Blades. But even the best hacksaw frame won't do you much good without the right hacksaw blade. For more on choosing a hacksaw blade, take a look at the box below. 📦

Good, Better, & Best: Hacksaw Blades

Having the right hacksaw frame is really only half the battle. Picking the right blade for your hacksaw is just as important. And the truth is, not all hacksaw blades are created equal.

You'll find three main types of hacksaw blades. The least expensive of the three are the standard, carbon-steel blades. These are good for cutting non-ferrous metals like aluminum and brass. They will work on mild steel, but they don't hold up as long as the other two types of blades.

Most of the time, I prefer to use high-speed steel blades. Since these blades are harder, the teeth stand up better to most cutting

tasks, particularly when working with steel. They cost a little bit more than carbon-steel blades, but they last longer too.

One problem with high-speed steel is that it's so hard and brittle, the blade can snap and break in pieces if it binds. So for this reason, you might want to switch to bi-metal blades. These blades have a high-speed steel edge that's joined to a softer steel back. This way you get the benefit of high speed steel with a lot less chance for blade breakage.

So, how can you tell what kind of blade you're buying? Most of the time they're marked — either on the package or on the actual blade.



Carbon Steel

High-Speed Steel

Bi-Metal

▲ **Check the Label.** High-speed steel and bi-metal blades are typically labelled on the blade.

SETTING UP Shop

Getting the Light Right

Good shop lighting makes for accurate work without straining your eyes.

■ For me, good lighting is one of the most important tools in my shop. It helps you avoid eye strain and makes it easier to work more accurately. Even more importantly, good lighting makes working in

the shop a whole lot safer.

To get all these benefits, there are a few things you'll need to consider. The first of these is selecting the best light source to use.

FLUORESCENT LIGHTS

For most woodworkers, fluorescent fixtures are a common choice. They're relatively easy to install, inexpensive to operate, and provide good light over a sizable area.

However, some of the drawbacks to this type of lighting are that the lights can sometimes be slow to start, make a humming noise, or flicker a bit. But most of these problems can be solved with a few simple steps. The box at left can help you troubleshoot some of these common problems.

But even the best fluorescent system can't give you the light you need if it's not able to focus the light correctly. So you'll want to be sure you use the right fixture.

Brighten the Shop. Choosing a fixture that's best suited to your

needs has a lot to do with the room you're working in. So the first thing you'll need to do is take a good look at your work area.

I always try to make sure the light falls onto my work area and doesn't get absorbed by the walls, ceiling, and other materials in the shop. The best way to do this is to have a flat surface behind the fixture and then paint the surface a light color, preferably white. You'll also find painting the walls a light color improves the lighting.

Reflectors. It's always tempting to buy the inexpensive fixtures without reflectors, like in the inset photo on the next page. These kind of fixtures rely on the ceiling to reflect the light back down. So the only time you'll want to use this

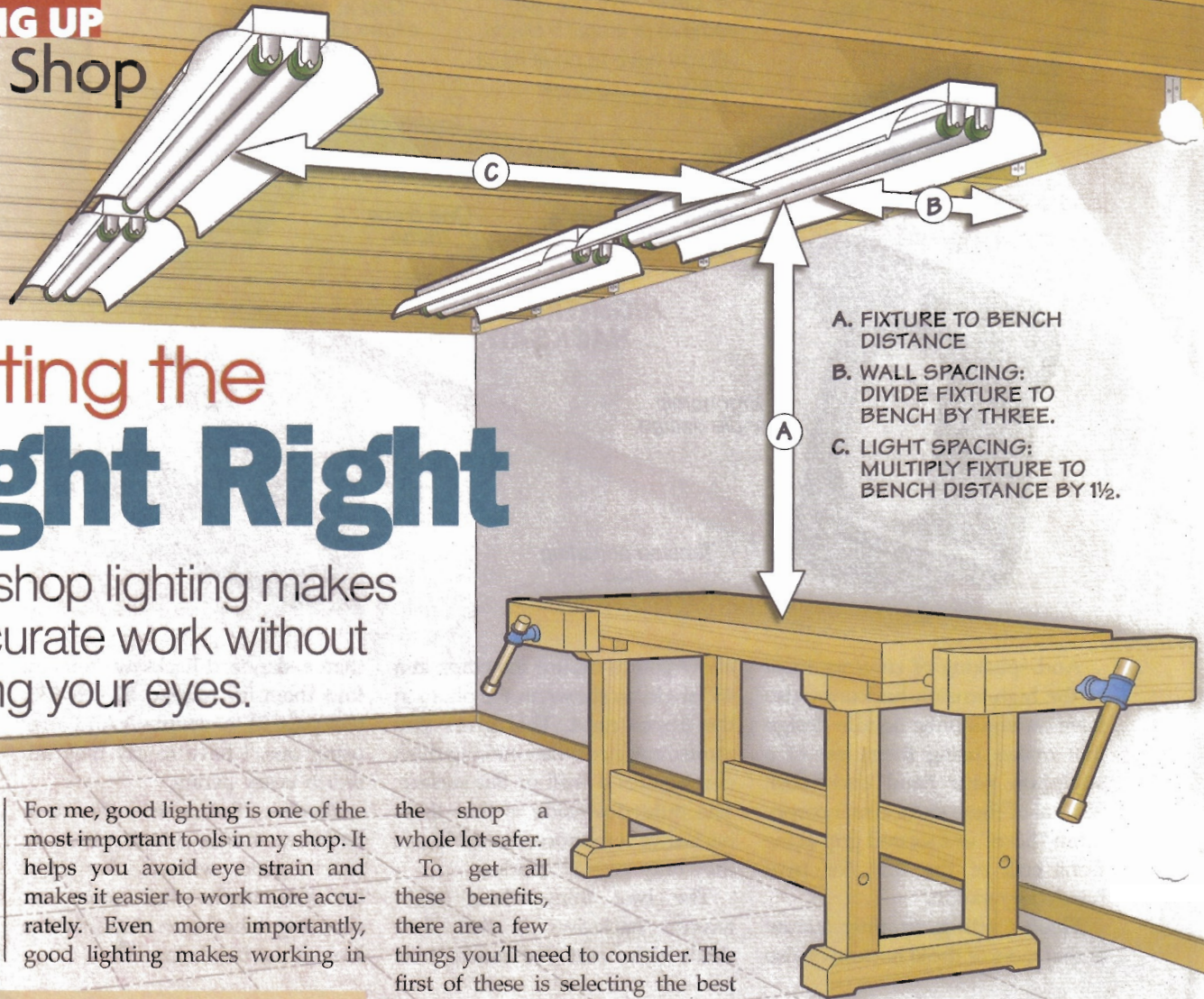

- A. FIXTURE TO BENCH DISTANCE
- B. WALL SPACING: DIVIDE FIXTURE TO BENCH BY THREE.
- C. LIGHT SPACING: MULTIPLY FIXTURE TO BENCH DISTANCE BY 1½.

Troubleshooting



Tube blinks on and off

- Time to replace tube



Black at the end of tube

- Will need to replace the tube soon



Tube hesitates or starts slow

- Needs new starter (if fixture has one)
- Replace ballast
- Cold - Will come on after a few minutes



Orange glow at ends

- Need new starter



Loud humming

- Tighten all fixture screws
- Replace the ballast if tightening screws doesn't solve the problem

type of fixture is when your ceiling is flat and light in color.

In my shop, I have an open ceiling with exposed joists. So I chose to use a fixture that has reflectors, like the one you see in the top photo at right. These reflectors bounce the light down toward the work surface. You'll also want to use these fixtures if your ceiling surface is dark or the fixtures are suspended from the ceiling.

LOCATING THE LIGHT

If your workbench is against the wall, it's always a good idea to try to position the fixture directly over worksurface. That way the light is not behind you causing shadows.

Distance From The Wall. There's a simple rule of thumb I like to use for locating a fixture over a workbench. And it requires taking only one measurement. I just measure the distance from my benchtop to the fixture (see illustration on opposite page). Then I simply divide that distance by three ($\frac{1}{3}$ the distance). This tells me how far away from the wall to mount the fixture.

The ceiling in my shop is eight feet high and the distance from my bench to the fixture is five feet. So I mounted the fixture on the ceiling a distance of 20" away from the wall.

More Than One Fixture. In most shops, one fixture won't be enough to supply adequate light. You'll need to install a number of fixtures to evenly light the space. So the next thing you'll need to determine is the farthest distance you can space the fixtures apart.

How Far Apart? Again, I return to my initial measurement of the workbench to the fixture. Then you can simply multiply that distance by $1\frac{1}{2}$ to find the maximum distance to leave between fixtures.

That means if the distance from the workbench to the fixture is five feet, the farthest apart my fixtures could be is $7\frac{1}{2}$ feet ($5 \times 1\frac{1}{2} = 7\frac{1}{2}$). If possible, I like to place them a little closer together because this lights the room even better. I also try to line up the fixtures so they run the length of the entire room.

Now that you know how far apart to space them, it's easy to figure out how many rows of fixtures you'll need to cover the room. Just determine the number of additional fixtures you'll need in each row. You'll find fluorescent fixtures come in 4' & 8' lengths and they're designed to be wired together in a series. So it's easy to put together a long string of light fixtures.

There's one final thing you'll need to think about if you're going



▲ **Reflectors.** Winged reflectors help to direct the light downward toward the worksurface.

to be using fluorescent lighting. And that's to make sure the fixture you're using is also right for the environment that exists in your workshop. This means making sure you get the right ballast. The box below has the information needed to help you with this.

As you can see, properly lighting your shop requires the same kind of preparation and setup as installing a new power tool. You'll want the right fixture positioned in the just the right place. 🛠️

▲ **Strip Fixture.** A fixture without reflectors depends on the surface directly above it to reflect the light.

Choose the Right Ballast

One thing you'll find about fluorescent lights that differs from other types of lighting is they require a ballast to operate. The ballast is located in the fixture (photo at right). It provides both a high voltage jolt to start the lamp and the low voltage stream needed for normal operation. You'll want to be sure you have the right ballast for the temperature in your shop.

So, when you choose a fluorescent lighting system, make sure you check the starting temperature of the ballast. If the temperature in

your work area is likely to drop below 50°, you'll want to use fixtures with ballasts that start at these lower temperatures. This is easy to determine. You'll find the minimum starting temperature and other information printed directly on the ballast.

This information will also tell you whether the ballast is a magnetic or electronic type. Electronic ballasts are a little bit more expensive but they tend to flicker less, run somewhat quieter, and work at lower temperatures.

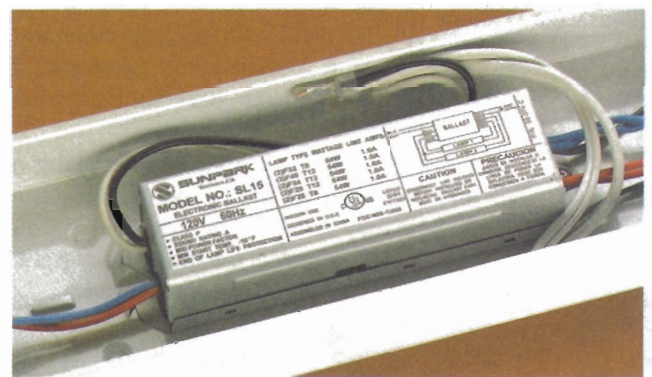

You'll find the noise rating printed on the ballast as well. A rating system of A, B, or C is most commonly used with "A" offering the quietest operation.

Classic Cove Molding

It's a simple, start-to-finish job on the table saw.

Nothing tops off a tall cabinet, bookcase, or display case quite like a wide, graceful cove molding. The wall cabinet, shown in the margin photo below, is a great example.

But the problem I'll often run into is that large cove moldings are only available in a few stock sizes and types of wood. So if you want to add this detail to a project, there are two choices. You can either design the project to fit the available cove molding, or better yet, take the time to make your own.

To do this, I turn to the table saw. Using a shop-tested technique, I make custom cove molding that fits my project perfectly.

How it Works. Now making a rounded cove cut on the table saw may sound a bit odd. But if you take a look at the drawings at right, you'll see how it works.

The idea is that the workpiece is fed across the blade at an angle to "scoop out" the cove profile.

When you squat down and look at a table saw blade straight on from the front of the saw, all you see is a thin

outline of the thickness of the blade. As you move slightly to one side, the profile of the blade takes on a narrow rounded or "cove" shape, as in the left drawings. Move further to the side and you see more of the profile of the blade and the "cove" becomes wider (right drawings). So by simply changing the feed angle of the workpiece (and the height of the saw blade), you control the size and shape of the cove cut.

The Steps. Making the cove cut is the unique part of the process,

but it's just one of the steps. The Section View in the left margin shows the final goal. In a nutshell, you want to start by creating the basic design of the cove. Then you can set up the table saw and make the cove cut in your workpieces. The bevel cuts that give the molding its "angled" profile come next. And finally, smoothing the cove cut wraps things up.

The Layout. I always start the job by getting out a pencil and paper to draw a full-scale pattern of the profile I want to make. Then,

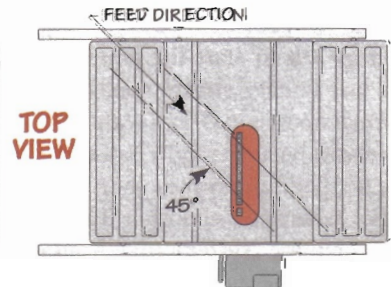
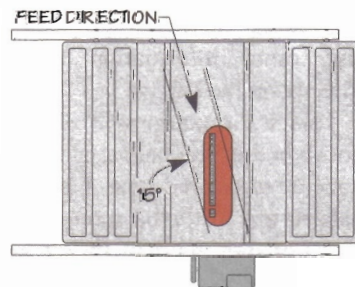
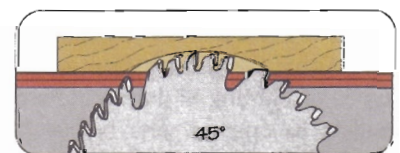
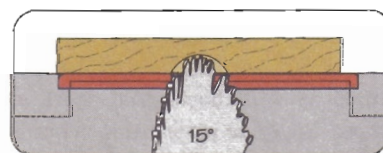
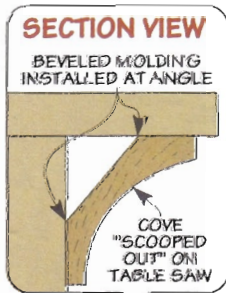

AS THE ANGLE OF APPROACH INCREASES, THE COVE BECOMES WIDER

I transfer the pattern to the end of one blank to use as a reference.

CUTTING THE COVE

With your workpieces ready to go, you can start setting up the table saw for the cove cut. As you can see in the main photo at left, this is done with the aid of two angled fences — one clamped in front of the blade and one behind it. To form the cove, the workpiece is fed between the two fences and across the saw blade in multiple *shallow* passes.

Two Parts. There are two aspects of the setup that will control the final shape of your cove cut. The first is easy. The depth of the cove cut (measured from your layout) will simply be the same as the height of the saw blade on your final pass. (You'll actually want to make the final pass a hair shallow to allow for smoothing the cut.)

The Right Angle. The trickier part of the setup is positioning the fences at the correct angle. As I mentioned before, the width of the cove cut depends upon the angle at which the workpiece passes over the saw blade. So the question is, how do you find this feed angle? My answer is to use a simple jig made from four strips of wood and

a handful of hardware (shown in the box at the bottom of the page).

Set the Fences. Once you've used the jig to mark the feed angle on the saw table, the next step is to set the fences. I start with the front fence.

As you see in the photo at left, the cove cut doesn't go to the edges of the workpiece. So you're not going to set the fence right on the pencil line you made to mark the angle. To get the cove "centered" in the workpiece, the front fence needs to be offset from the line, as shown in the drawing above.

You can measure this offset from the workpiece and then position the front fence to correspond. And with the front fence clamped in place, sandwich the workpiece between the two fences and clamp the rear fence down.

Making the Cut. Once the fences are positioned, cutting the cove profile is pretty routine. Raise the saw blade about $\frac{1}{16}$ " above the table for the first pass. Then, use a couple of push blocks to slowly feed the blank across the blade. You shouldn't feel much resistance. If

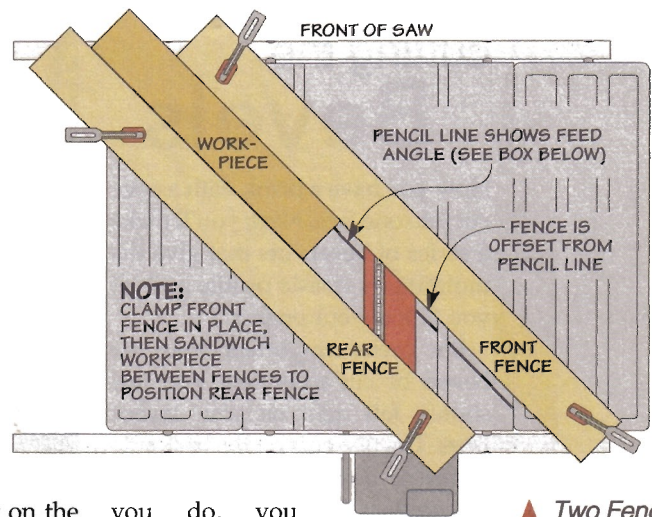

you do, you might be taking too deep a bite. After the first pass, just raise the blade another $\frac{1}{16}$ " and repeat the process.

When you get to within about $\frac{1}{16}$ " of the layout line, take a close look at the face of the cove cut. What you'll see on the surface are very small diagonal ridges left by the saw blade. So from here on, you'll want to take even finer cuts ($\frac{1}{32}$ " or less). This, along with a slow, steady feed rate will give you the smoothest possible cove cut and less work later.

With the cove cuts behind you, the next task is to cut the bevels that allow the molding to fit a case.

▲ **Two Fences.** One angled fence clamped in front of the blade and one clamped behind it allow you to safely guide the workpiece as you scoop out the cove.

Finding the Angle: A Foolproof Method

When it comes to finding the correct fence angle for a cove cut, the adjustable jig, shown at right, can't be beat. It takes all the guesswork out of setting up the fences.

As you can see, the jig is simply two short pieces of stock and two longer pieces fastened at the corners with bolts and wing nuts. To use the jig, you loosen the wing nuts and shift the two long arms until the distance between them matches the desired width of the cove cut (inset photo). Then tighten everything down.

Next, at the table saw, begin by raising the saw blade to the full

depth of the cove cut. Then, I take a couple pieces of tape and place one at each end of the blade, right at the point where the teeth pass through the table. This lets you easily make a pencil line marking the limits of the cut the blade will make.

Now, set the jig over the blade and rotate it until the inside edges of both long arms rest over the marks on the tape. Finally, mark a pencil line along the inside edge of the front arm (large photo). This marks the feed angle for the cove cut.

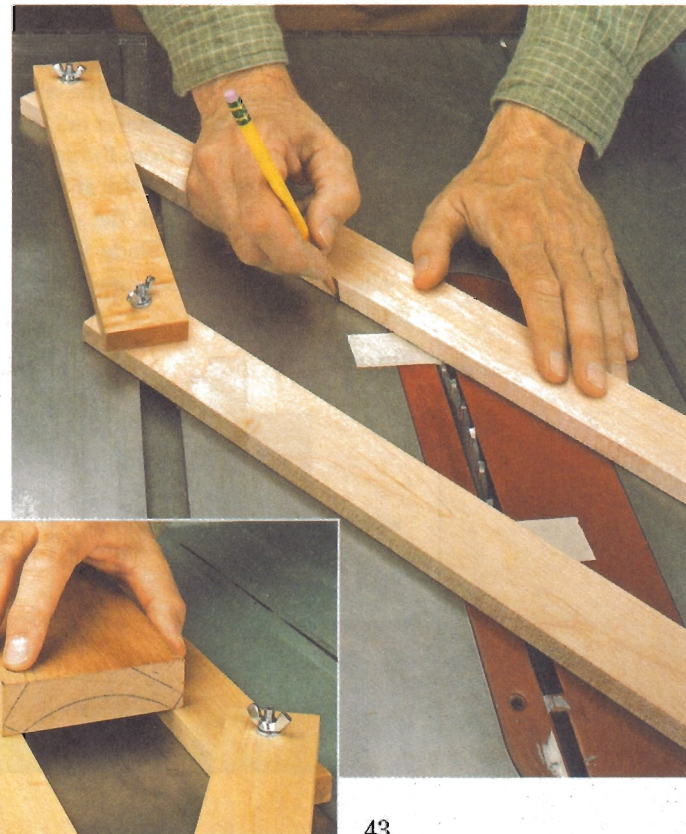

cutting the Bevels

Now you have a blank with a cove cut into one face. Next, you'll make a series of bevel cuts that give the molding its classic profile and let you fit it to your project.

It's pretty important that the bevels be cut accurately. The cuts should fall right on your layout lines. The two cuts on the back side of the cove should be at 90° to one another and the bevel cut at each end should also be square. But don't worry, there are a couple of tricks that will make this go pretty easy.

Two Goals. You really have two things you need to accomplish here. The first is getting all the bevel angles right. The second is maintaining good control of the workpiece as you make the cuts. This is simply a matter of getting the saw set up correctly and then making the four cuts in the correct order.

Find the Angle. The first thing you need to do is set the blade angle of the saw. And the neat trick here is that all you need is one angle setting to make all four of the cuts. The angle you use will depend on how you designed the cove to fit on the project. The cove I'm making here will stand tall but not stick out too far from the case.

An easy way to find the angle is to simply set the blank flat on the saw and adjust the blade until it aligns with the layout line on the

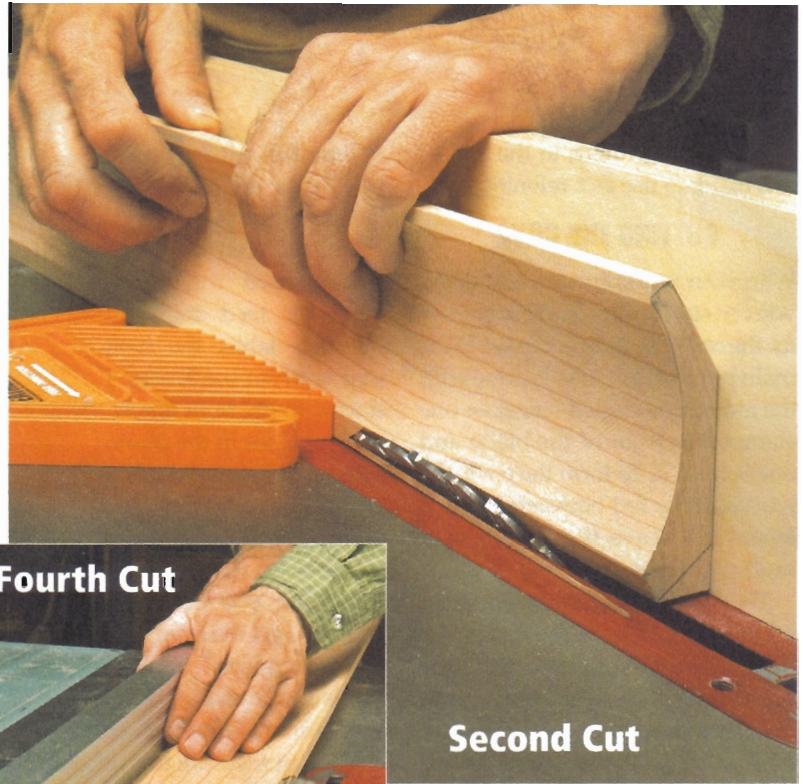

Fourth Cut

Second Cut

end. A test cut will tell you if you have it right. And once you've found this angle, you can make the cuts in different orientations to create the complementary angles.

The Right Order. With the blade adjusted to the correct angle, you're ready to start the beveling process. The key is to make the cuts so that you always have a stable surface riding against both the rip fence and the saw table. The step-by-step drawings below show the best order for the cuts.

As you can see in the photo above, I used a tall auxiliary rip

fence for the first two "upright" cuts. A featherboard helps keep the workpiece tight to the rip fence.

I like to set the fence a little wide of my mark and then sneak up on the layout line. And after each bevel is completed, you'll have to readjust the fence for the next cut.

The first three cuts are made with the rip fence positioned so the blade is tilted away from the fence. But for the fourth and final cut you'll shift the fence to the opposite side of the blade. This very light, "trapped" cut allows you to feed the partially cut molding with the flat, back side on the table.

That's all there is to it. The profile is complete, but you still have one important task before the cove molding is ready to install.

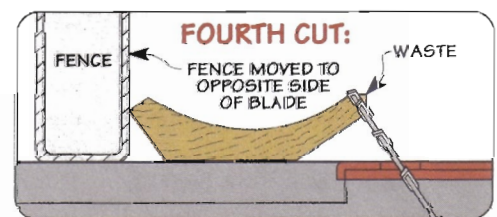
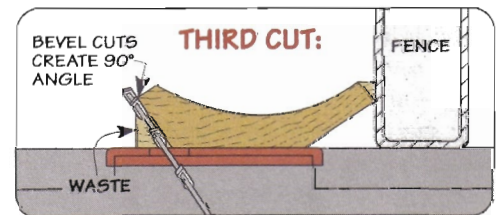
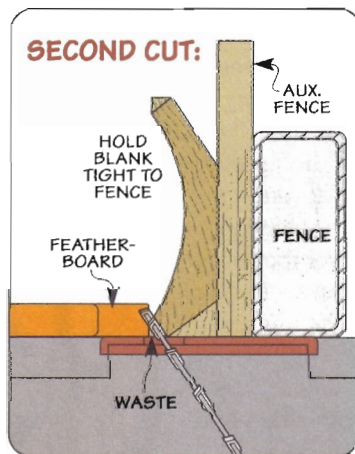
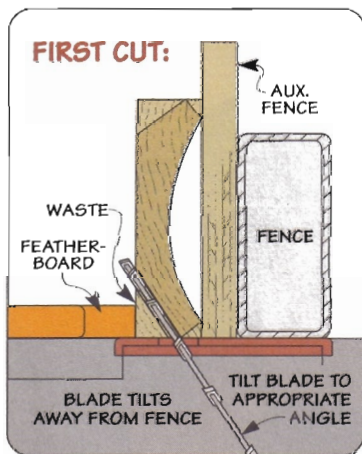

smoothing the Cove Cut

At this point, most of the hard work is done. But the face of the cove cut is still covered with the tiny diagonal ridges left by the saw blade. You'll find that even with the smoothest-cutting blade and a careful technique, you can't avoid having to do a little cleanup work.

Putting this finishing touch on the cove molding can be a pretty quick job. But it's also not one you want to rush through. I find that a perfectly smooth result is worth a little bit of extra effort.

Scrape and Sand. I used to start in on smoothing the cove cut with sandpaper wrapped around a shop-made sanding block. But if I had a lot of cove to clean up, this was pretty slow going. So I tried something different, and it really cut down on the work.

Now, before I do any sanding, I put a sharp burr on a curved scraper and put it to work removing the saw marks on the cove cut (main photo at right). The curved edge of the scraper cuts

more aggressively than coarse sandpaper. The key is that you don't want to try to scrape across the entire profile all at once. Just find a spot on the scraper that will match the curve of the cove cut and use it to clean a small portion at a time. Then work across the width of the cove and along its length. I think you'll be surprised how quickly the saw marks disappear.

When the cove looks pretty clean, I switch to sandpaper and a sanding block to finish the job. I like to use the profile sander shown in the inset photo (see sources on page 51). A shop-made sanding block will also work.

I like to start sanding with 120-grit sandpaper. This allows you to quickly even out any grooves or ridges left by the scraper and remove any remaining saw marks.



◀ **Easy Sanding.** The adjustable profile sander shown at left, makes easy work of smoothing the cove cut.

Finally, I switch to 150 or 180-grit sandpaper to leave a ready-for-finish surface on the cove cut. And finally, for tips on fitting the cove, check out the box below. 🛠️

Fitting the Cove Molding

Once I've gone the extra mile to make some really nice-looking cove, I like to do an equally good job of mitering it to fit. But since the cove molding isn't simply installed flat on the sides of the project, this involves cutting a compound miter. An easy way to do this on the table saw is shown below.

The secret is to hold the workpiece in the same orientation that it will be installed on the project. This can be done easily by attaching the simple sled shown in the drawing below to your miter gauge. The raised lip on the front edge of the sled keeps the cove in position while making the miter cuts.

As you see in the photo, the saw blade is left at 90° but the miter gauge is set to 45°. The first workpiece is positioned "upside down" in the sled and is mitered from the right side of the blade. To cut the mating miter, you switch the sled to the left side of the blade.

SHOP TIP

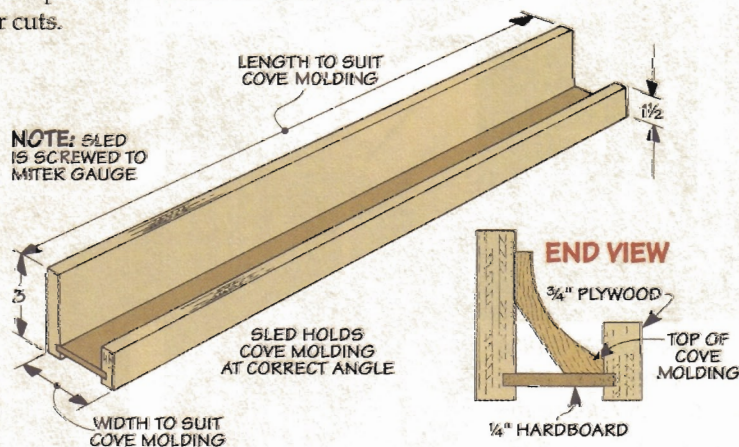

table saw accessories

Snap-in Splitters

These easy-to-use accessories add an important safety feature to your table saw.

Do you know where your table saw splitter is? If you're like a lot of woodworkers, then the answer to that question is either "No" or "On the shelf gathering dust."

The splitters that come with most table saws are clunky contraptions that combine a flimsy splitter with an awkward blade guard. And while most of us have good intentions of using them, once they're

taken off the saw, they are usually never put back on.

The good news is there are several high-quality, replacement splitters available. Besides being easy to install, they pop on and off your saw in just a few seconds.

What a Splitter Does. Before looking at specific splitters, it helps to know just what a splitter does. The main job of a splitter is safety. When ripping, it prevents the kerf from closing up and binding on the blade, which can cause kickback.

Using a splitter can also improve the quality of cut. By keeping the workpiece from coming in contact with the back of

the blade, you'll have less burning and fewer saw marks to remove.

Three Models. I looked at three after-market splitters that are all easy to use. Two of them, the *Merlin* and *Biesemeyer* look similar to the stock splitters — just without the blade guard. (Note: For the safest cuts, you should use a separate blade guard with these splitters.) The third one, the *Micro Jig* splitter, takes a different approach (box on the opposite page). To find out where to get each of these splitters, turn to page 51.

SPLITTER FEATURES

As I mentioned before, what really sets the *Biesemeyer* and *Merlin* apart is the ability to install and remove them in a few seconds. The key to doing that is a quick-release mechanism located inside the saw.

Push-Button Release. On the *Merlin*, the splitter is released by simply pushing a button. The makers of the *Merlin* recommend drilling a hole in the insert plate so that you can push the button with a pencil and then lift off the splitter. You can see how this works in the first inset photo shown at left.

Reattaching the *Merlin* is also a snap. You hook the back end in first. Then, lower the front into the slot in the insert plate. This two-point connection system keeps the long splitter rigid.

◀ **Easy On.** Clip the splitter in the rear mount and rock it forward until it "clicks" into place.



► **Release Hole.** Drill a hole in the throat plate so you can release the splitter with a pencil.

Single-Point Attachment. On the other hand, the *Biesemeyer* has a simpler, single-point attachment. You install it by slipping it through the insert plate until it “clicks.”

To remove the *Biesemeyer* splitter, you need to remove the insert plate and pull a small, spring-loaded knob (inset photo at right). Depending on the saw, you may need to lower the blade as well. Both systems work well, but being able to remove the *Merlin* splitter without reaching inside the saw is a lot more convenient.

There’s one more thing to note here. The quick-release mechanisms are mounted to the saw with the same holes used for the stock splitter and guard. So you’ll need to purchase a splitter that’s made to fit your specific table saw.

Splitter. Aside from the quick-release feature, another advantage of the *Merlin* and *Biesemeyer* is that they are made from thick steel that’s less likely to flex. And the shape of the splitters is unique as well. The difference between these two splitters is pretty obvious. The

Biesemeyer looks like a sharpened knife blade. The leading edge is tapered so that a workpiece won’t catch.

The *Merlin* has a much longer profile. This keeps the workpiece from twisting away from the fence and spoiling the accuracy of the cut.

It’s hard to say which style is better. If properly set up, you shouldn’t really even notice that a splitter is there. And once aligned, both splitters worked great.

Anti-Kickback Pawls. The final feature of these after-market splitters to look at are the anti-kickback pawls. Like the splitter itself, the pawls are thicker and more rigid than those on stock splitters. The pawls on the *Biesemeyer* splitter can accommodate most stock sizes with teeth that run nearly the entire length of each pawl.

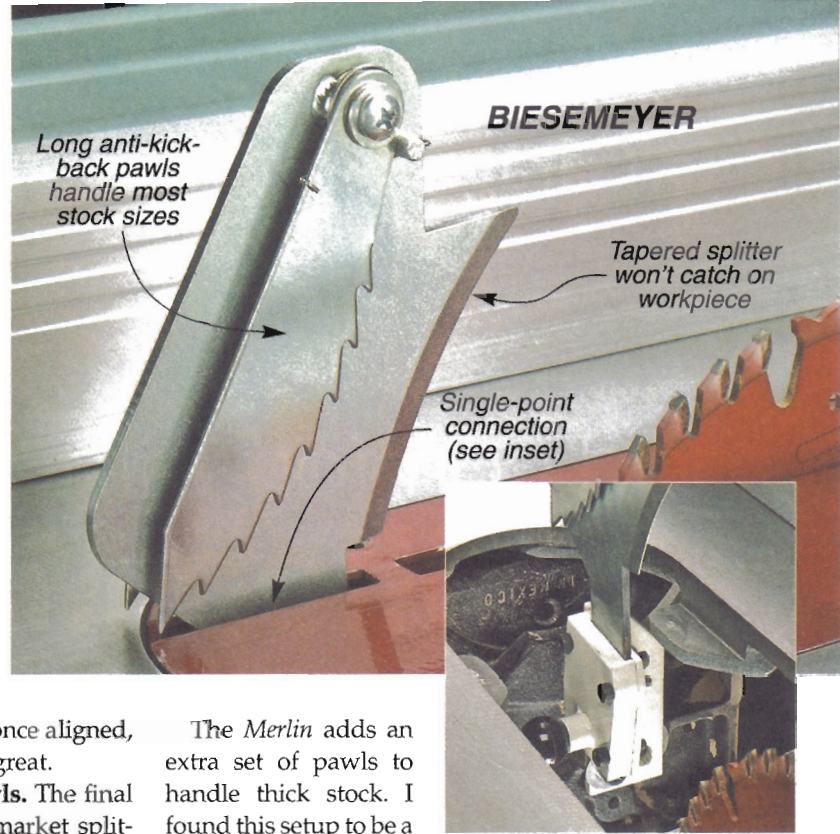

The *Merlin* adds an extra set of pawls to handle thick stock. I found this setup to be a littler easier to work with and less likely to leave marks.

Price. If there is a drawback to these splitters, it’s the cost. Both the *Biesemeyer* and the *Merlin* cost more than \$100. But considering just how easy they are to use, you may just find they’re well worth it.

▲ **Quick Release.** A tug on the knob is all it takes to release the splitter.

Keep it Simple: Micro Jig

Right off the bat, you’ll notice the *Micro Jig MJ* splitter is completely different from the two shown above, as you can see in the photos at right. The first difference is the size. While the other splitters are large and made from steel, the *MJ* is just a short plastic fin.

You can also see that it snaps into three holes drilled in a zero-clearance insert plate. (A drilling guide is provided.) This universal design means that this splitter will work on just about every saw.

Featherboard Effect. The *MJ* splitter does have one feature that the others don’t. In addition to preventing the kerf from closing up behind the saw, it has a built

in “featherboard effect” that keeps the workpiece from wandering away from the fence (drawing below). The fin is slightly offset from the centerline. This causes the splitter to push the workpiece against the rip fence. The splitter comes with

two fins that give you four different pressure settings to adjust how much of a featherboard effect you want.

About the only downside of the *MJ* is that it will only work on 90° cuts. Since it’s fixed to the insert plate and not to the saw’s arbor-tilting mechanism, you’ll need to remove the splitter for bevel cuts.

Finally, the cost of the *Micro Jig* splitter matches its size. You can find it for about \$20. (For sources, turn to page 51.) That’s a small price to pay to add a huge safety feature to your table saw.

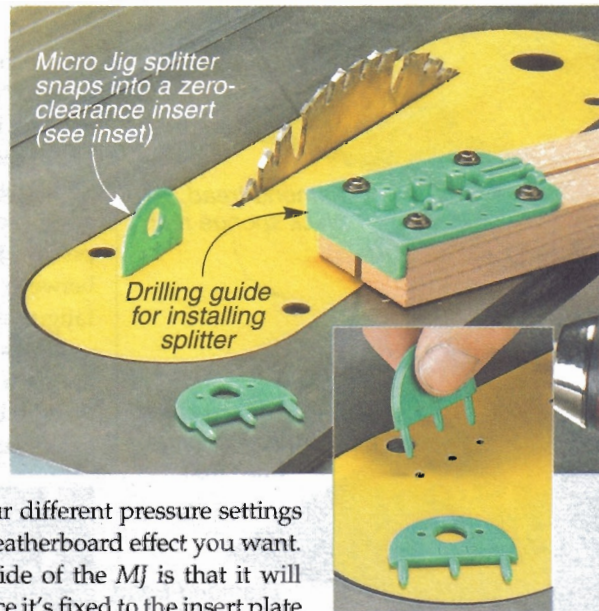

▲ **Variable Sizes.** “Plus” signs on each side of the splitter fins indicate the strength of the featherboard effect.

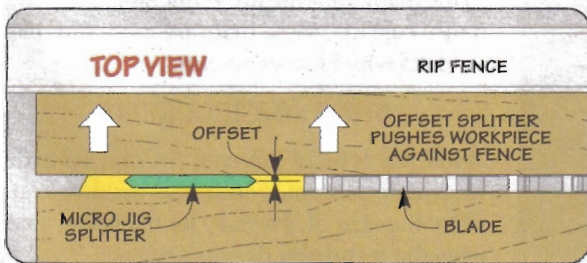

add comfort with **Shop Mats**

Enjoy working on a concrete floor. All you need is an anti-fatigue mat.



Heavy-duty, 3/8"-thick rubber mat

Ribbed, 3/8"-thick sponge mat with tapered edge to reduce tripping hazard

Diamond-tread, 1/2"-thick sponge mat

Embossed vinyl, 3/8"-thick sponge-back mat

Diamond-tread, 9/16"-thick vinyl spongeback mat (see inset)

There's nothing like spending a nice long weekend in the shop. But if your shop floor is a cold, hard slab of concrete like mine, you probably end up with more than a finished project — like sore feet and legs, along with an aching back. Let's face it. Concrete is a hard and unforgiving surface.

What's the Solution? Working on a concrete floor might seem like something you just have to "tough out." You can't easily tear it out or cover it all with a "softer" surface.

But there's a quick and easy solution — an anti-fatigue mat like the ones you see on this page. (For sources, see page 51.) These inexpensive mats are designed to place a barrier between you and the floor to reduce the fatigue associated with working on concrete.

A World of Choices. The mats shown here are just a few of the dozens available. So you'll want to be sure to keep in mind a few things before you add one (or two) to your shop.



MAT MATERIAL

The first thing you'll need to do is decide between a solid rubber mat or a mat made from a sponge-like material.

Rubber Mats. Solid rubber mats are very common (top photo in margin). They're heavy-duty, so they'll take a lot of abuse. Often made from recycled tires, rubber mats provide a cushioned surface that's impact resistant. So a dropped chisel or tool won't do much damage — to the mat or the tool. Another plus, rubber resists most oils and finishes that might get spilled on it.

Sponge Mats. You'll also find mats made of a sponge-like (foam) material (the second and third mats at left). A sponge mat provides more cushion than a rubber mat, but it does have one problem, it doesn't wear as well.

To solve this problem, many manufacturers make a combination version called a spongeback mat (lower two mats in margin). Here, a top layer of vinyl or rubber is bonded to the foam underneath. While still providing a nice cushion, these mats are more durable. And it's why I like them best.

OTHER CONSIDERATIONS

While the type of material the mat is made from is important, you'll also need to consider the size of the mat, its thickness, and even the texture on the surface.

Sizing a Mat. Getting as large a mat as possible seems like a good idea. This way, you could cover as much of the concrete floor as possible. But bigger isn't always better.

At roughly \$2 to \$4 a square foot, covering a large area would be costly — assuming you could find a mat large enough. And second, covering an entire shop with a "soft" material makes moving tools and equipment around the shop just about impossible.

The best thing to do is size the mat (or mats) to cover the areas where you stand and work the most. For me, that's at the front of my table saw and workbench. I like the mats to extend about 1' to each side and behind the area I work in. In most cases, a 3' x 4' mat is just about the right size.

There are times when a standard-size mat just won't fit the area you have to work in. A solution to that is to create a custom mat. For that, check out the box at right.

How Thick? Another consideration is the thickness of the mat. Just like the overall size, a thicker mat isn't always better.

Sure, a thicker mat will have more "cush," but it can actually increase fatigue and be a hazard. Why? A thicker mat makes you feel less stable, so you end up swaying and shifting your feet more often as you work. And the extra thickness is a tripping hazard.

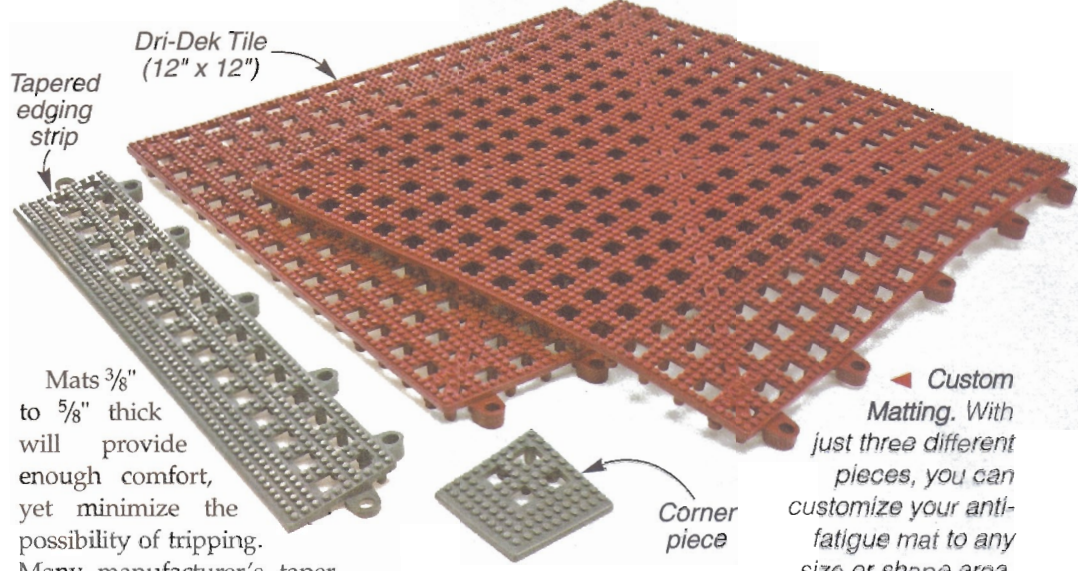

Mats $\frac{3}{8}$ " to $\frac{5}{8}$ " thick will provide enough comfort, yet minimize the possibility of tripping. Many manufacturer's taper the edges as well to reduce the hazard (see opposite page).

A Little Texture. Besides the taper, most mats will have a textured surface to help prevent slipping. A little texture is nice, but I've found that too much can make it hard to sweep the mat clean.

Beat the Cold. One last thing. Concrete stays cold a long time. And most mats will provide some insulation. But if you expect to spend a lot of time working in the shop during cold weather, you might want to take a look at the *Footwarmer* shop mat shown below.

The *Footwarmer* has a built-in heating element. So no matter how cold it is, the mat radiates a constant heat to keep you more comfortable.

The *Footwarmer* comes in two sizes, but the larger model (FWB-16x36) works best at a bench, like you see in the photo below.

◀ **Custom Matting.** With just three different pieces, you can customize your anti-fatigue mat to any size or shape area.

Customized Mats: Dri-Dek Tiles

One of the more interesting anti-fatigue products available is the snap-together tile and trim pieces shown above. *Dri-Dek* tiles are ideal for any place you need to have a customized, anti-fatigue mat.

Each 12"-square, vinyl tile has close to 300 flexible legs that absorb the shock of walking on a concrete floor, see photo at right. As you can see in the main photo on the opposite page, the tiles can be snapped together to fit around any arrangement of tools, benches, or cabinets in your workshop. And the open grid allows sawdust and chips to fall right through. Cleaning up is just a matter of rolling back the mat and then vacuuming everything up.

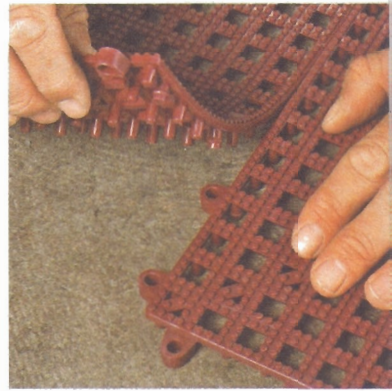

▲ **Snap Together.** Mating pins and tabs secure the tiles to each other as well as the edging and corner pieces.

The tiles do stand off the floor about $\frac{1}{2}$ ". To provide a smooth transition around the outside edge of the mat, you can snap on tapered edge strips and corner pieces (top photo). One final plus, all the pieces are available in 12 different colors, so it's an easy way to add a little pizzazz to your shop as well.

The only real downside to *Dri-Dek* is the cost. The tiles run a little under \$4 apiece, with the edging (\$2) and corners (\$1) just a bit less. So a 3' x 4' mat with edging and corners strips will cost about \$72 (about \$25 more than a similar rubber or sponge mat). For sources, refer to page 51.



Cushioned Warmth. Beat the fatigue and cold with a heated shop mat that simply plugs in.



questions from

Our Readers

perfect planing on

Short Stock



My planer manual recommends not planing anything less than 12" long. Is there any way to thin down a short board without having to plane it by hand?

John Wilson
Austin, TX

Like most woodworkers, it's hard for me to toss out any type of "scrap" — especially a small piece with interesting figure or grain. The problem is making the best use of the piece that you have usually means using it on a small project. And for that, you often need to plane the piece down a bit thinner.

But you can't just run a short board through your thickness planer. Most planers recommend a minimum length that you can plane safely. (Usually about 12".)

The Problem. If you try to plane anything shorter than what's recommended, you run the risk of the workpiece getting caught between the infeed and outfeed rollers. This can cause it to lift off the planer bed. At best, this may only cause severe snipe (a deeper cut near the end of a board). At worst, the board can get chewed up, damaging the cutter-head and planer in the process.

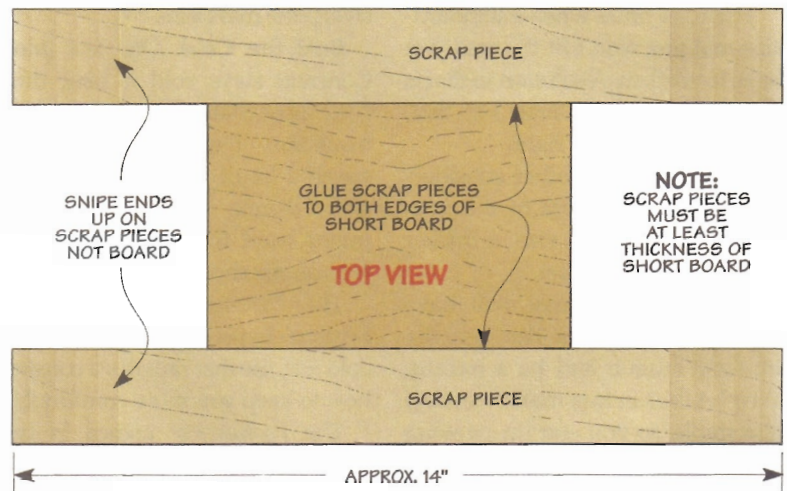

Adding Support. But there is a solution to this problem — and that's to provide a little extra support for the workpiece. To do this, I glue longer, narrow scrap pieces to both edges of the short board, as illustrated in the drawing above.

These support pieces will span both feed rollers, so the workpiece stays flat on the bed of the planer like you see in the drawing at left. When you glue the supports in place, keep in mind that they need to be at least the same thickness as the

workpiece (slightly thicker is okay). And be sure they're glued flush with either the top or bottom face.

Eliminate the Snipe. With this technique, you end up with a planed surface that's mirror smooth. And if your planer has a tendency to snipe, it ends up on the support pieces instead of your workpiece like you see in the drawing above. Once you have the board planed to the thickness you want, all you have to do is cut off the narrow support pieces.

One last thing. You can use this same technique to eliminate snipe no matter how long the workpiece is. This way, none of the workpiece will go to waste.

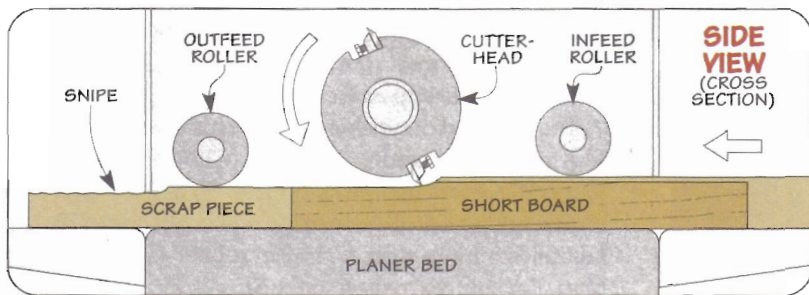

Sources

MAIL ORDER SOURCES

COVE BITS

The three styles of cove bits covered in the article on page 8 are available from most woodworking stores as well as the sources listed in the margin. Some home centers may also carry the basic cove bit.

The particular cove bits we featured are made by *Freud*. Other manufacturers and the *Woodsmith Store* carry similar cove bits. You'll find the most useful sizes are the 1/4", 3/8", and 1/2" radius bits.

SHOP VACUUM UPGRADES

The article on page 12 features a number of accessories you can buy to upgrade your shop vacuum. You should be able to find most of the accessories at any home center.

The only ones you might have trouble locating are the heavy-duty, flexible hose and the filters. The 12'-long hose (12F01.01) is available from *Lee Valley*. They also have a 24'-long hose (12F01.02) if you need an even longer reach.

As for the filters, the margin lists a couple of sources for the *CleanStream* models.

MODULAR WORKSTATION

To build the three pieces of the modular workstation on page 16, you'll need a variety of hardware. The aluminum channel, screws,

and finish washers can be picked up at just about any hardware store or home center.

The rest of the hardware is available from the *Woodsmith Store* and *Rockler*. The parts (and model numbers) you'll need are: pin hinges (26955), 3" wire pulls (39875), 6" wire pulls (44121), shelf pins (33860), 3" swivel casters (31883), and 3" locking casters (31870).

MARKING KNIFE

Other than the blade itself, all the hardware for the marking knife came from a local hardware store.

The 5/16"-wide, right (01.041.08) and left (01.042.08) bevel blades we used are available from *Japan Woodworker* (see margin). Just be sure you have the blades in hand before you cut the grooves in the handle to size. Blade widths can vary slightly, so if you have the blade before you start you can cut the groove to fit perfectly.

ROUTER CIRCLE JIG

There isn't much hardware required for the router circle jig (page 32). You should be able to find the screws, washers, knobs, and a 6" lazy Susan at a hardware store or home center.

If you have trouble locating a lazy Susan or the 4"-long spiral

downcut bit that will give you the best results, check out the margin. Both *Amana* (46218) and *Freud* (76-110) make a spiral downcut bit that will work just great.

HACKSAWS

Just about any home center or hardware store will carry a high-tension hacksaw (page 38) and the blades that go with it. But if you should have trouble finding one, check out *McMaster-Carr* and *MSC Industrial* (see margin).

TABLE SAW SPLITTERS

A splitter is a must for safely ripping stock on the table saw. The handy snap-in splitters shown on page 46 are all available from the *Woodsmith Store* and the sources listed in the margin.

ANTI-FATIGUE MATS

Anti-fatigue mats are available from at many hardware stores and home centers. In fact, at many home centers, the matting is on a big roll and you simply pay by the foot for the length you need.

But if you want to choose from a wider variety of materials, styles, and sizes, or order the *Dri-Dek* tiles to customize the matting in your shop, check out the sources listed in the margin at right.

Similar project supplies may be ordered from the following companies:

Woodsmith Store
800-444-7002
woodsmithstore.com

Cam Clamps, Casters, Cove Bits, Knobs, Lazy Susan, Pin Hinges, Shelf Pins, Splitters, Wire Pulls

Rockler
800-279-4441
www.rockler.com

Cam Clamps, Casters, Cove Bits, Knobs, Lazy Susan, Micro Jig Splitter, Pin Hinges, Shelf Pins, Shop Vacuum Accessories, Wire Pulls

Bridge City Tools
800-253-3332
www.bridgecitytools.com
Vario-Pro Profile Sander

Amana Tools
800-445-0077
www.amanatool.com
Cove & Spiral Downcut Bits

Freud Tools
800-334-4107
www.freudtools.com
Cove & Spiral Downcut Bits

Reid Tool
800-253-0421
www.reidtool.com
Anti-Fatigue Mats, Casters

McMaster-Carr
630-833-0300
www.mcmaster.com
Anti-Fatigue Mats, Hacksaws & Blades, Knobs

MSC Industrial
800-645-7270
www.mscdirect.com
Hacksaws & Blades

Lee Valley
800-871-8158
www.leevalley.com
Cam Clamps, Micro Jig Splitter, Shop Vacuum Hose & Accessories

Japan Woodworker
800-537-7820
japanwoodworker.com
Marking Knife Blades

Micro Jig
407-696-6695
www.microjig.com
Micro Jig Splitter

W. L. Gore & Associates
800-758-6755
www.cleanstream.com
CleanStream Filters

Dri-Dek
800-348-2398
www.dri-dek.com
Dri-Dek Products

ShopNotes Binders

Keep your issues organized!

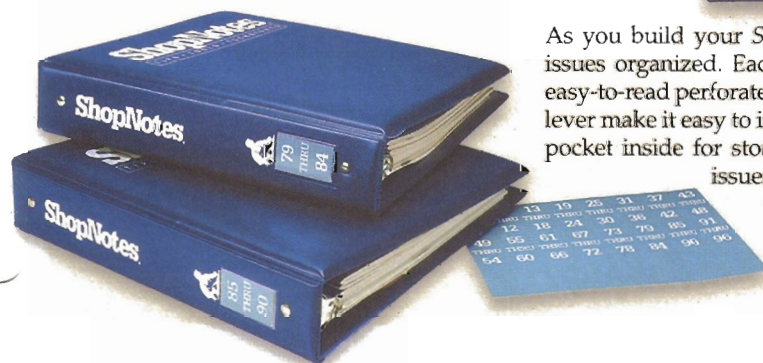

As you build your *ShopNotes* library, here's a way to keep your issues organized. Each binder features durable vinyl covers and easy-to-read perforated number tags. Snap rings with a quick-open lever make it easy to insert and remove issues. And there's an extra pocket inside for storing notes. Each binder holds a full year (6 issues) of the new, expanded *ShopNotes*.

Visit www.ShopNotes.com to order these binders, or call 1-800-347-5105.

ShopNotes Binder

○ 701950-SIN83 (Holds 6 issues).....\$12.95

Scenes from the Shop

Marking Knife. Looking to improve the accuracy of your layout work? Then you'll want to take a look at the shop-made marking knives you see below.

Each knife starts out by wrapping a Japanese-style blade with a wood handle and copper ferrules. Then, the ferrules are peened to give the handle a classic look. To change the look of the copper, oil is brushed on the ferrules and then heated with a torch. With four different "recipes," you're sure to find just the right look.

The article on page 24 will guide you through the step-by-step process for making the marking knife. You may even want to make a pair of handles — one for a left beveled blade and another for a right bevel. This way, you'll be ready to handle any layout task.

