

**ROUTER  
SPECIAL**

**PROJECTS, TIPS, & TECHNIQUES**

# ShopNotes®

Vol. 15 Issue 85

www.ShopNotes.com

## **ROUTER TABLE** **+10** **TOP-NOTCH** **UPGRADES**

- Build a Full-size Router Table for under \$50
- Optional Storage Cabinet Plans Included

### **PERFECT MITERS ON YOUR TABLE SAW**

- New Table Saw Sled

### **2 WAYS TO MAXIMIZE YOUR SHOP SPACE**

- Hi-Tech Hanging System
- Easy Hardware Storage

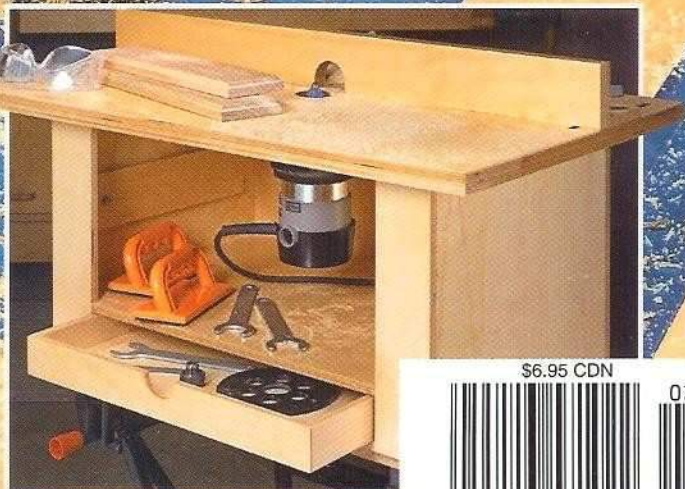

\$6.95 CDN



DISPLAY UNTIL FEB. 27th, 2006







# Cutoffs

**A** table-mounted router is at the top of my list of “must-have” shop tools. A router table allows you to work more safely, efficiently, and accurately. In fact, it’s such an important tool in my shop, I just can’t imagine working without one. So we decided to dedicate this issue of *ShopNotes* to one of our favorite tools — the router table.

For starters, we’re featuring an all-new router table design. The idea behind this project was to start out with a simple, practical design that could be built quickly and inexpensively. So we decided to limit ourselves to a single sheet of Baltic birch plywood — a \$50 investment.

The final design features a full-size table top that tilts up to provide easy access to the router, an easy-to-adjust fence, and a handy storage drawer. All in all, a lot of router table for a small amount of money.

But the part of this project I like the best is how versatile it is. Start with the basic router table, then you can add a simple base cabinet. From there you can upgrade the cabinet even further by adding doors and drawers.

Finally, if you want to take this router table (or any other router table) to the next level, be sure and check out our Top 10 Router Table Accessories starting on page 8.

For me, this router table project is what *ShopNotes* is all about — helping you get the most out of your shop.

*Terry*



Quick & Easy Router Table

page 18

## in the shop

### Splinter-Free Cuts in Plywood \_\_\_\_\_ 38

*Learn all you need to know to get clean, splinter-free cuts in plywood time after time.*

## setting up shop

### Versatile Pegboard \_\_\_\_\_ 40

*Put pegboard to use in your shop this weekend with these seven handy ideas.*

## mastering the table saw

### Setting up for Safe Ripping \_\_\_\_\_ 44

*Here's what you need to know to make safe rip cuts on the table saw a sure thing.*

## great gear

### Zero-Clearance Inserts \_\_\_\_\_ 46

*Want to improve the cut of your table saw? We take a look at zero-clearance inserts.*

## ultimate garage

### Handy Hang-Ups \_\_\_\_\_ 48

*Conquering the clutter in a garage isn't a problem with this handy organizing system.*

### Q&A \_\_\_\_\_ 50

### Sources \_\_\_\_\_ 51



This symbol lets you know there's more information available online at [www.ShopNotes.com](http://www.ShopNotes.com)



from our  
Readers

# Tips for Your Shop

NOTE: OVERALL HEIGHT IS 31"

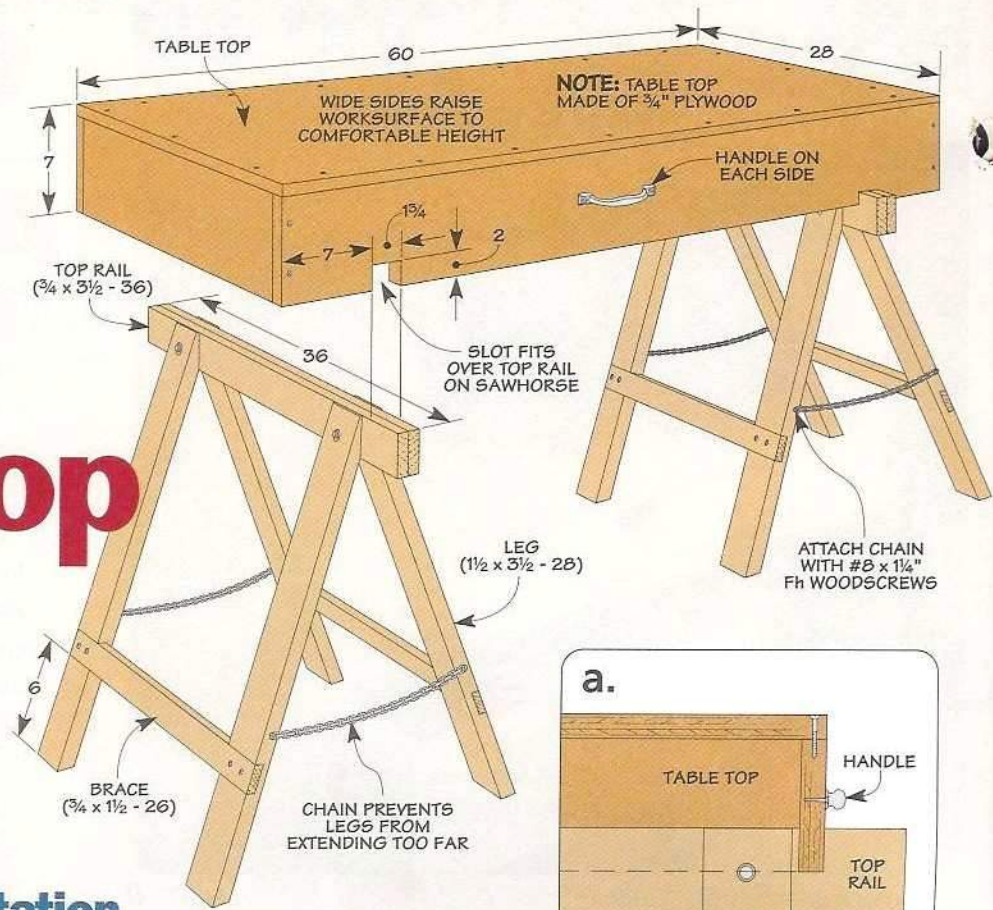

## Portable Assembly Station

My workshop is small. And I don't have room for extra workbenches and assembly tables. So I built the portable table you see illustrated above. It can be set up

for use and then quickly taken down and stored along the wall of my shop when it isn't needed.

The top of the table is simply a plywood box that's notched at the sides. That way, the top can sit securely on a pair of folding sawhorses. A handle located on each side makes it easy to lift and move for set up and storage.

The sawhorses are designed to fold for easy storage. The legs are two pairs of 2x4's angled at the top end and bolted to 1x4 top rails. The two top rails are then connected by a hinge, like you see in Figure 1 at left. To assemble the sawhorse, you'll first want to screw the hinges to the top rail and then remove the hinge pins. Next, bolt the legs to the rails and then re-install the hinge pins. A piece of chain keeps the legs from extending too far.

Now, when you pick up the sawhorse by a top rail, the legs close up. Just squeeze the top rails together and the legs spring open.

Arnold R. Johnsen  
Brooklyn Center, Minnesota

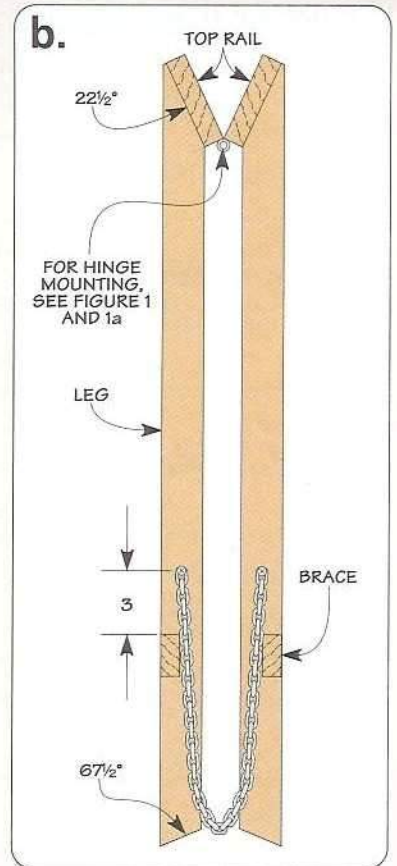
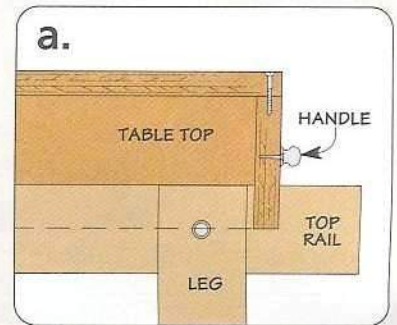
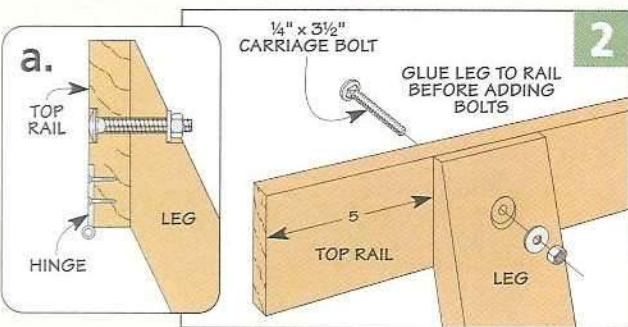
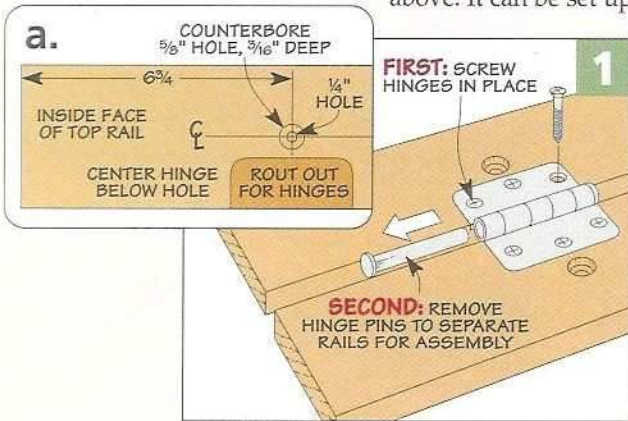



## Transparent Template

Accurately positioning the screw holes when making a new router plate or router table insert is always a challenge. But I found way to eliminate any chance of error. I make a copy of my router plate on a transparency at the copy machine.

It's easy to do. All you need is some transparency film for copiers and your router plate.

After taking the baseplate off your router, lay it on the copier.

Then load the transparency into the tray of the copy machine and make a copy of your router plate.

Now, you can lay the film on the material. And since you can see through the film, it can be moved into just the right position for you to mark the hole locations. The template is durable so you can store it away for future use.

*Ted Pietrzak  
Auburn, California*



## Submit Your Tips

If you have an original shop tip, we would like to hear from you and consider publishing your tip in one or more of our publications. Just write down your tip and mail it to: *ShopNotes*, Tips for Your Shop, 2200 Grand Avenue, Des Moines, Iowa 50312. Please include your name, address, and daytime phone number (in case we have any questions). If you would like, FAX it to us at 515-282-6741 or send us an email message at: [shop-notes@shopnotes.com](mailto:shop-notes@shopnotes.com). We will pay up to \$200 if we publish your tip.

## The Winner!

Congratulations to Arnold Johnsen of Brooklyn Center, Minnesota. His tip on making a portable assembly station was selected as winner of the *Porter-Cable* router just like the one shown at the right. His assembly station is easy to build and stores away when it isn't needed.

To find out how you could win a *Porter-Cable* router check out the information above. Your tip just might be a winner.

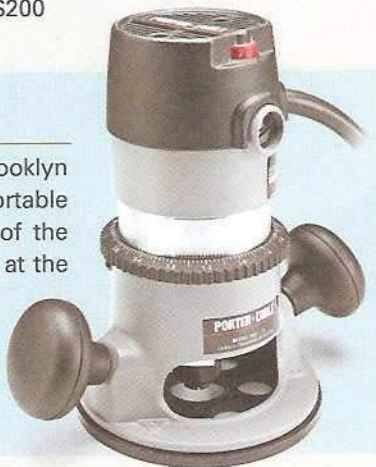

PUBLISHER Donald B. Peschke

EDITOR Terry J. Strohman

SENIOR EDITORS Bryan Nelson, Vincent Ancona

ASSOCIATE EDITORS Phil Huber, Ted Raife

ASSISTANT EDITORS Ron Johnson, Mitch Holmes,  
Randall A. Maxey

EXECUTIVE ART DIRECTOR Todd Lambirth

ART DIRECTOR Cary Christensen

SENIOR GRAPHIC DESIGNER Jamie Downing

SENIOR ILLUSTRATOR Roger Reiland

ILLUSTRATORS David Kallemyn, Peter J. Larson

CREATIVE DIRECTOR Ted Kralicek

SENIOR PROJECT DESIGNERS Ken Munkel,  
Kent Welsh, Chris Fitch

PROJECT DESIGNERS/BUILDERS Mike Donovan,  
John Doyle

SHOP CRAFTSMEN Steve Curtis, Steve Johnson

SR. PHOTOGRAPHERS Crayola England, Dennis Kennedy

ASSOCIATE STYLE DIRECTOR Rebecca Cunningham

ELECTRONIC IMAGE SPECIALIST Allan Ruhnke

VIDEOGRAPHERS Craig Ruegsegger, Mark Hayes

*ShopNotes*® (ISSN 1062-0696) is published bimonthly (Jan., March, May, July, Sept., Nov.) by August Home Publishing, 2200 Grand Ave., Des Moines, IA 50312. *ShopNotes*® is a registered trademark of August Home Publishing. ©Copyright 2006 by August Home Publishing. All rights reserved. Subscriptions: Single copy: \$4.95. One year subscription (6 issues): \$27.95. Canada/International add \$10 per year, U.S. funds. Canadian Subscriptions: Canada Post Agreement Number 40038201. Send change of address information and blocks of undeliverable copies to P.O. Box 881, Station Main, Markham, ON L3P 8M6, Canada BN 84597 5473 RT. Periodicals Postage Paid at Des Moines, IA and at additional mailing offices. Postmaster: Send change of address to *ShopNotes*, P.O. Box 37103, Boone, IA 50037-2103.

[www.ShopNotes.com](http://www.ShopNotes.com)

## ONLINE SUBSCRIBER SERVICES

- **ACCESS** your account
- **CHECK** on a subscription payment
- **TELL US** if you've missed an issue
- **CHANGE** your mailing or e-mail address
- **RENEW** your subscription
- **PAY** your bill

Click on "Subscriber Services" in the list on the left side of our home page. Menus and forms will take you through any of the account-maintenance services you need.

## HOW TO REACH US:

FOR SUBSCRIPTIONS, ADDRESS CHANGES  
OR QUESTIONS, WRITE OR CALL:

**Customer Service**  
2200 Grand Ave., Des Moines, IA 50312  
800-333-5854 8 a.m. to 5 p.m. CT

OR SEND AN E-MAIL TO:  
[orders@shopnotes.com](mailto:orders@shopnotes.com)

**AUGUST HOME**  
PUBLISHING COMPANY

Printed in U.S.A.



## Squaring Jig

One of the difficult tasks of working alone is squaring large face frames and cases. It seems that I can never get my tape measure to behave when I need to measure from corner to corner to square things up. So I built the squaring jig you see in the photos at right to make this a simple task.

The jig is easy to build. I made the corner block with a 90° notch by first drilling a centered hole in a square piece of  $\frac{3}{4}$ " plywood. Then you can set up the miter gauge on your table saw and make two 45° cuts in the block. Finally, screw the corner block to a  $\frac{1}{2}$ " plywood backing block, like you see in the illustration below.

The arm is a piece of  $\frac{1}{2}$ "-thick hardwood. A hole in one end of the arm allows you to secure the corner block to the arm with a  $\frac{1}{4}$ " hex bolt.

The jig makes it easy to work from the far end of a frame or case. You first slide the

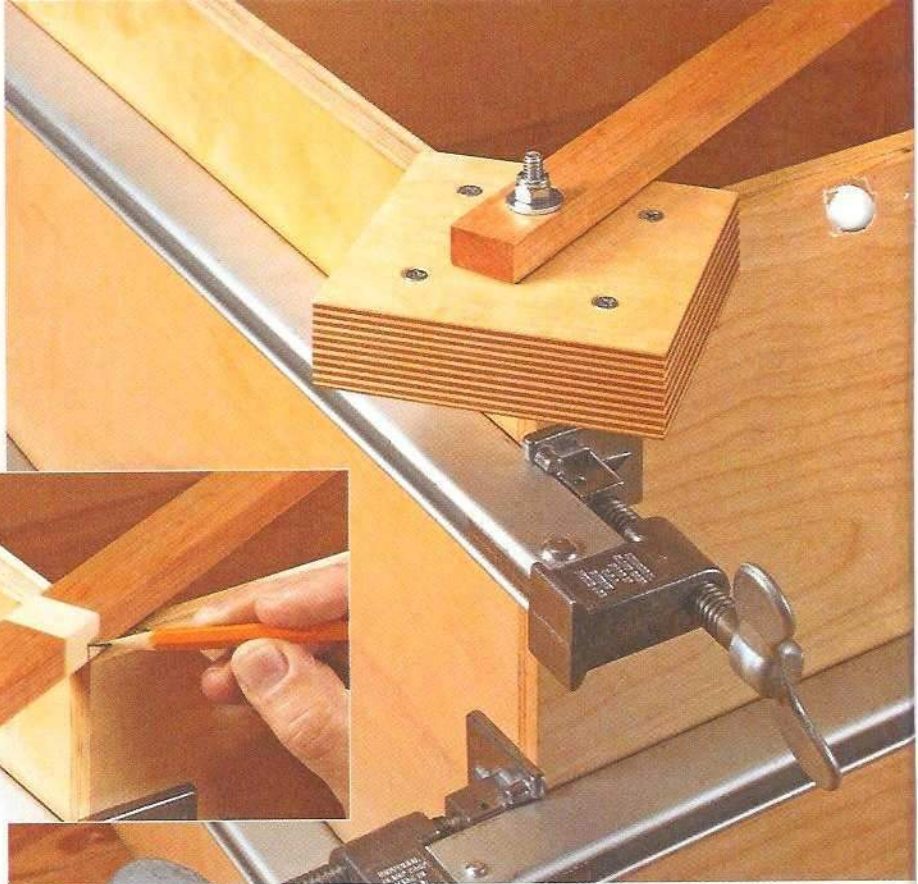

block over the corner and lock it into position. Then just extend the long measuring arm diagonally across to the opposite corner.

With this jig, you don't need to remember any measurements. Just place a piece of masking tape at the end of the arm and mark the corner, like you see in the inset photo above. Then you can quickly

move the jig to check the other diagonal and compare this distance to the mark you just made.

Now, I no longer worry about the size of the case or face frame I'm working with. It's easy to get them squared up. And I don't need anyone around to give me a hand.

*E. John De Waard  
Marshall, Michigan*

## Quick Tips

► Whenever glue needs to be placed into small, hard-to-reach places, Istvan Balogh of Tulsa, OK, slips a drinking straw into the spout of the glue bottle. This extends the reach and lets him apply glue into places too small for his glue bottle to fit. With the simple straw extension, glue can also be quickly dispensed with pinpoint accuracy into even the smallest joint spaces.

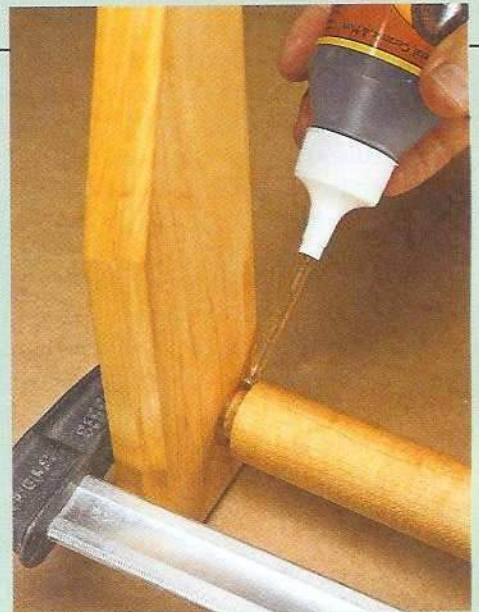

## Free Tips ON THE WEB

Get more wood-working tips free.

Visit us on the Web at [ShopNotes.com](http://ShopNotes.com)

Sign up to receive a free shop tip by email every week.

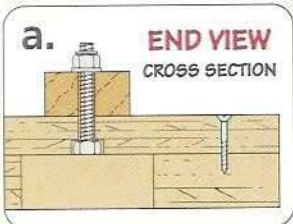
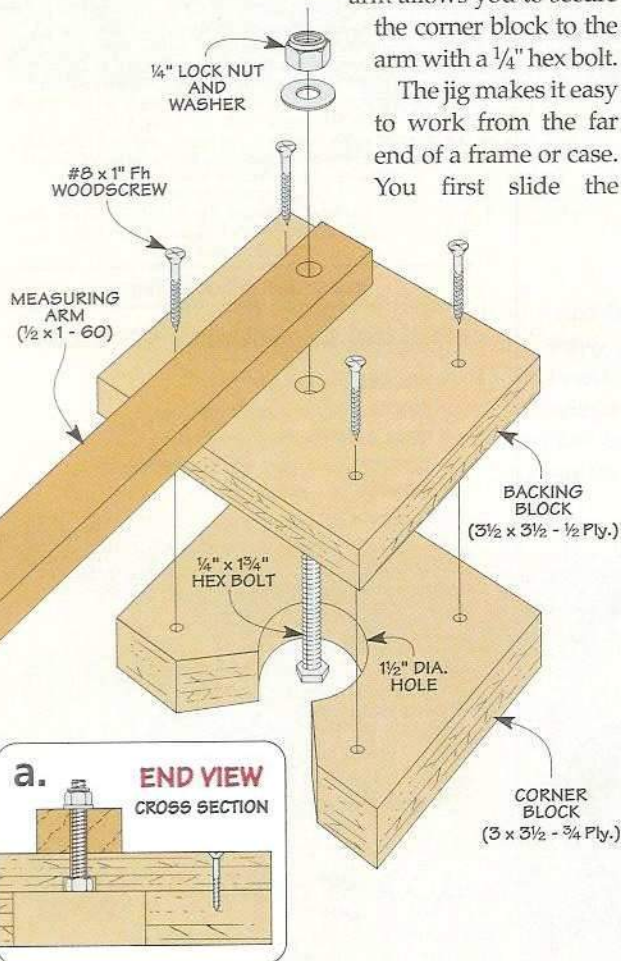



## Table Position Jig

Whenever I tilt my drill press table for angled drilling, I struggle to get the table squared up again using just my square. To help me do this with a lot more precision, I built the drill press table positioning jig shown in the photo at right. It's easy to build and accurate to use.

The jig is simply a dial indicator attached to a plywood arm (see drawing at right). The arm is clamped to a set-up rod that can be chucked in the drill press. You can use any  $\frac{5}{16}$ "-dia. rod. (I used an old drill bit).

To square the table, just slip the set-up rod in the chuck of your drill. Then raise the table until it just slightly depresses the extended indicator point. Next, rotate the chuck by hand (don't turn on the power) and watch for movement of the needle on the dial. The table is square when the reading on one side of the table is the same as that on the other side of the table.

The jig takes only a few minutes to set up. And it's more accurate than using your square.

*Frank Penicka  
Mount Pearl, Nfld., Canada*

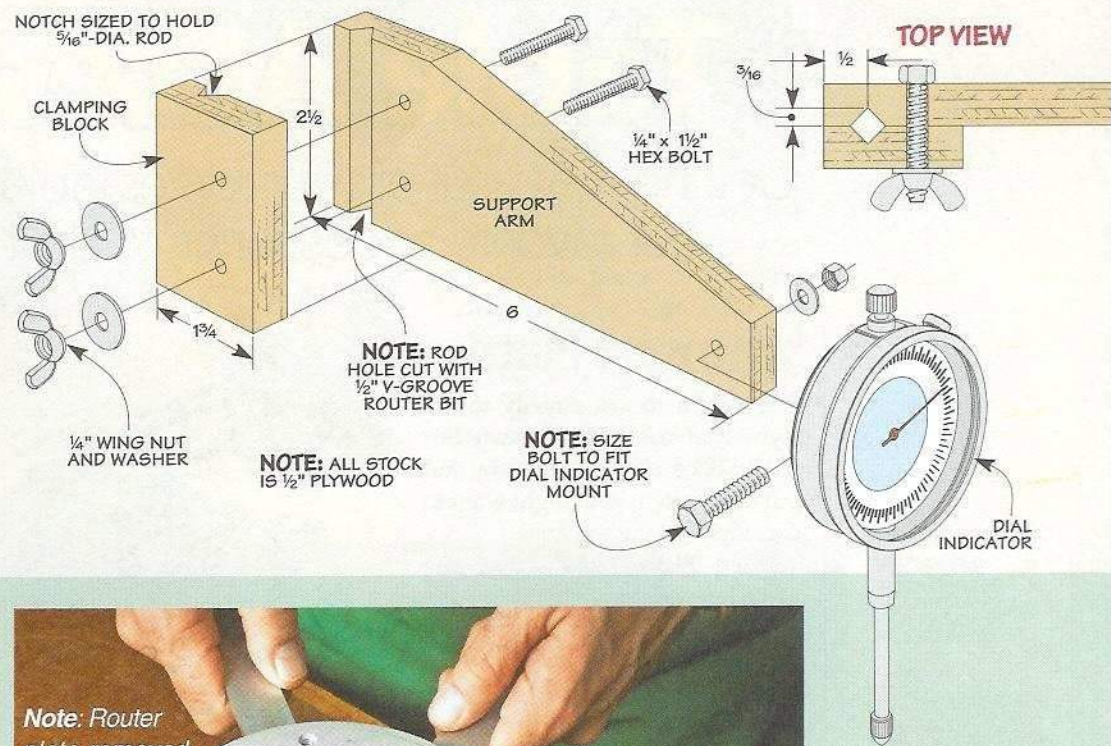

▲ **R.B. Himes** of Vienna, OH, uses a replacement pencil eraser for a protective cap on his air tools. The eraser fits over the air connection port to keep dirt and debris out.



▲ **C. Jeffrey Goldberg** of Tucson, Az, uses a plumber's Mack Lavatory Washer to keep his router wrenches from slipping off the collet during bit changes. He uses contact cement to attach the washers to both wrenches and then trims the washer away at the opening (see inset).



# Top 10 Router Table Accessories

Get the most out of your router table. Here are our favorite accessories to do it right.

## 1 Insert Plate

Screwing a router directly to the top of a table is quick and easy. But if you'll be changing bits in and out fairly often, you might want to consider making a change.

**Insert Plate.** What I'm talking about here is upgrading your router table with an insert plate. The idea behind an insert plate is simple. With the router attached to the plate and slipped into an opening in the top of the table, you have a secure system for routing. But here's the really nice part — instead of having to work *under* the table to make changes and adjustments, you simply "pop" the plate (and router) out and work above the table.

The insert plates you'll find most often are made from phenolic and aluminum (photo at left). And depending on the material and thickness, the price can vary from \$25 to around \$100.

**Custom Openings.** Regardless of how the plate is made, most fea-

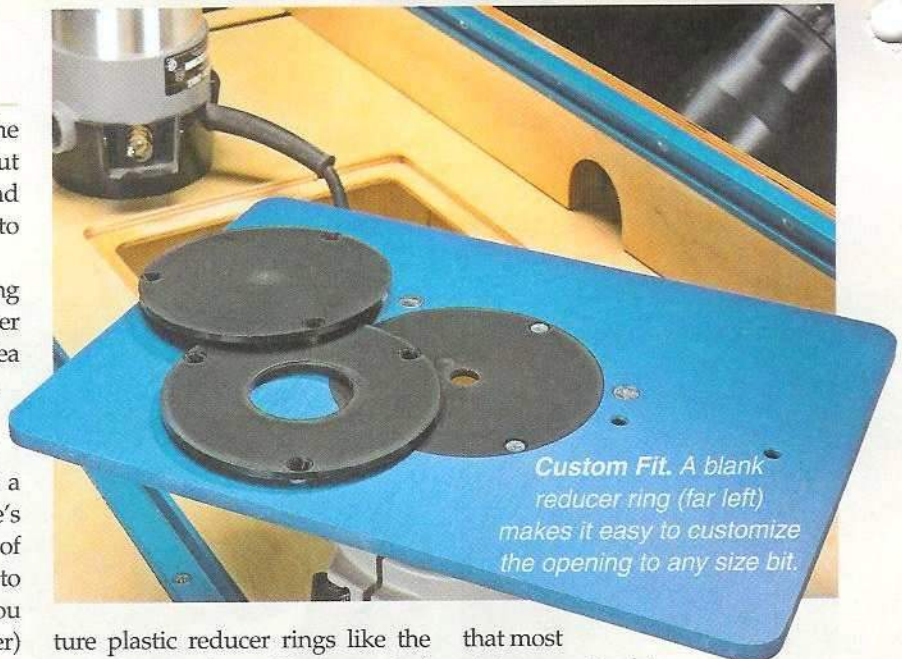

*Custom Fit. A blank reducer ring (far left) makes it easy to customize the opening to any size bit.*

ture plastic reducer rings like the ones you see above. Having a set of reducer rings allows you to install (or customize) a ring to minimize the clearance around the bit. This makes for safer cuts and provides more support for the workpiece.

**Final Considerations.** The one thing you'll need to keep in mind when choosing an insert plate is

that most plates are sized to fit the router table made by the same manufacturer. So if you already have a router table, you may need to modify the opening to fit the plate. For an easy way to rout an opening for an insert plate (or modify the one you have), check out Shop Short Cuts on page 16.



## 2 & 3 T-Track and Miter Track

An insert plate makes it easy to get your router in and out of the table. But when it comes to taking your table to the next level, there are a couple accessories you'll want to add — and that's the T-track and miter gauge track shown at the upper right.

A slot in the track accepts a flange (or toilet) bolt (lower left photo), while some versions accept the head of a hex bolt. By slipping an accessory, like a stop block, over the bolt, you can position the accessory anywhere along the track. Locking it in place is just a matter of tightening the knob.

What T-track has going for it is that it's fairly inexpensive, starting at about \$8 for a 2' piece and running up to \$14 for a 4' length. You will need to keep in mind that T-track can vary from  $\frac{3}{8}$ " up to  $\frac{3}{4}$ " in thickness. So be sure your fence design allows you to screw the T-track securely in place.

**Add a Miter Track.** Besides T-track, another way to make your router table work harder is the miter gauge track you see at right. Instead of mounting to the fence, the miter track slips into a groove cut in the top of the table.

By doing this, you can use your miter gauge (or any other accessory with a miter bar) for operations that would be difficult or impossible to

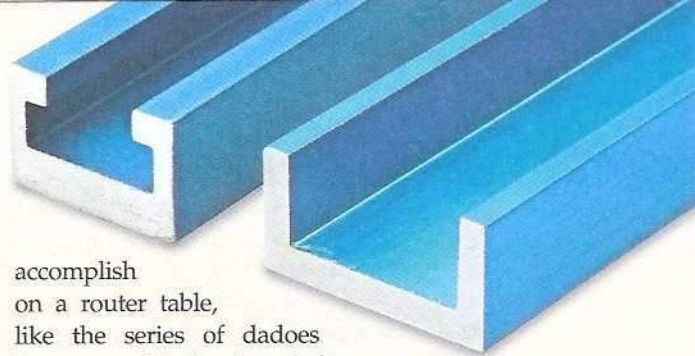

accomplish on a router table, like the series of dadose being routed in the photo below.

And just like T-track, the miter track can be used for adding a featherboard to ensure your workpiece stays tight against the fence.

Miter track is available in different lengths and the pricing is similar to the T-track. The 3'-long piece I bought cost around \$17. For sources of both T-track and miter track, turn to page 51.

▲ **Simple Designs.** T-track (left) and miter track are nothing more than simple metal extrusions. But they make it a snap to use and mount accessories.

### T-Track.

T-track allows you to use a flange bolt and knob to attach a wide range of accessories to your fence.



**Start with T-Track.** Of the two, the most versatile is T-track. T-track is nothing more than a metal channel you install in your router table fence. This way, you can quickly and easily mount featherboards, bit guards, and stop blocks (more on these later), allowing you to work more accurately and safely.

Regardless of the manufacturer, all T-track works basically the same.

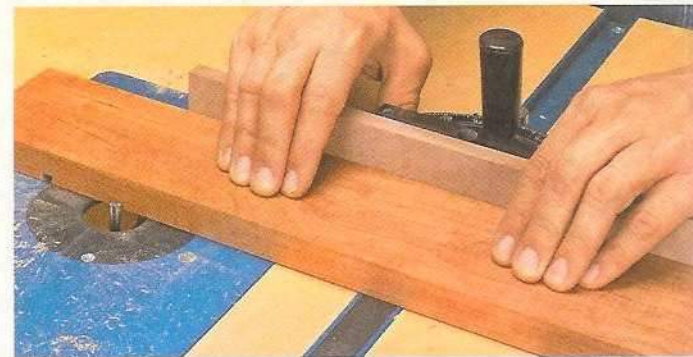

▲ **Miter Track.** Adding a miter track to your router table allows you to use other accessories, like the miter gauge and auxiliary fence you see here.

## 4 & 5 Keep the Power Under Control

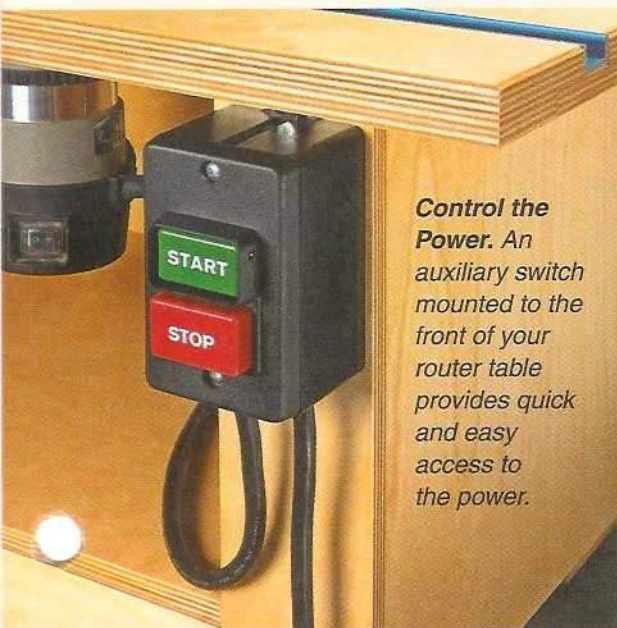

**Control the Power.** An auxiliary switch mounted to the front of your router table provides quick and easy access to the power.

One of the problems you'll run across when working at a router table is the hassle of searching underneath the table trying to find the power switch. The first time you need to do it quickly, you'll appreciate the added safety of an auxiliary ON/OFF switch. The switch you see at left only costs about \$25, and this is a pretty inexpensive way to get better control.

**Speed Control.** Another way to keep better control is to adjust the speed of your router to suit the task at hand. If your router doesn't have this capability, you can add it by installing the speed control unit at right. Using it is just a matter of turning the router on, adjusting the speed as necessary, and then routing. (You can expect to spend about \$40.)



**Adjusting the Speed.** With a variable-speed control unit, you can match the router speed to the size of the bit and the type of material.



## 6 Featherboards

Running a small piece of wood safely past a router bit spinning at 20,000 RPM can be a challenge. There's always the possibility the workpiece will kick out, lift up, or even kick back toward you. So it's a good idea to put that T-track on the fence and the miter gauge slot in the table to good use and add a featherboard or two.

**The Benefits.** Whether you mount the featherboard to the table or fence, it applies pressure against the workpiece. The flexible fingers allow the workpiece to slide smoothly in one direction, helping prevent the workpiece from moving up, away, or kicking back at you.



▲ **Extra Hand.** Featherboards work like an extra hand, keeping a workpiece tight against a table or fence.

You can make your own featherboard, but there are a number of manufacturers that make inexpensive models that are easy to use. One of my favorites is the Bench Dog Feather-Loc shown in the margin.

Bench Dog has models you can mount to the fence or table. The table version has a short miter bar for locking the featherboard anywhere along the miter track with the turn of a knob. Prices vary from \$20 to \$25 depending on the model.



**Tandem Model.** If you plan to rout tall workpieces on edge, Bench Dog offers a version that stacks two featherboards together with a spacer in between. This tandem version provides additional pressure to ensure the workpiece stays flat against the fence.

**Stopped Cuts.** When you need to start or stop routing a workpiece at a precise point along its length, then a stop attached to the fence of the router table is the accessory you need. A stop can be as simple as a wood block clamped to the face of the fence. But many manufacturers have made stops even more convenient by designing them as a separate accessory that attaches to the T-track they manufacture.

A manufactured stop is easy to adjust and clamp in place. And it's a whole lot quicker than trying to



deal with a wood block and separate clamp (or two).

**Compatibility.** But you might run into trouble trying to adapt some manufactured stops to the fence and T-track you're using. So I've found that an easy solution is to simply turn the Bench Dog Feather-Loc upside down and turn it into a handy stop, like you see in the photo above.

## 7 Corral the Dust

Whether it's hand-held or mounted in a table, a router tends to create more dust and chips than you can imagine — and it spreads the mess around the shop faster than you might think possible.

**Collect the Dust.** To minimize this problem, the first thing you should do after attaching the fence to the router table is bolt a dust hookup in place, like the one you see in the photo at right.

The nice thing about adding a dust hookup is that it doesn't cost a lot. The one you see at right is only \$13 and makes hooking up your shop vacuum or dust collector hassle-free. Most woodworking stores or mail-order sources carry dust hookups for router table fences (refer to page 51).

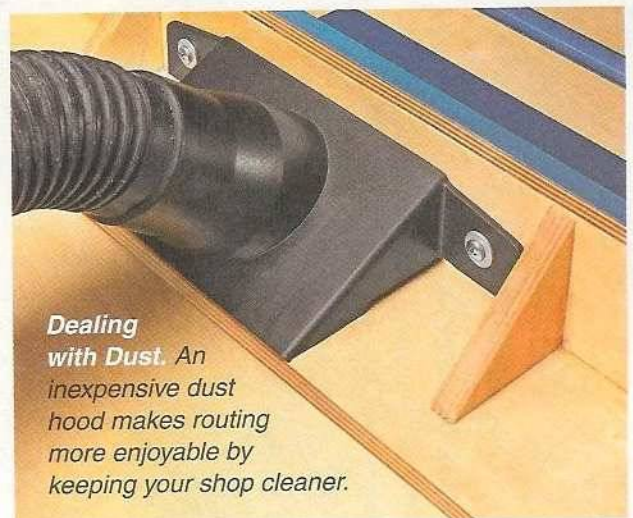

**Dealing with Dust.** An inexpensive dust hood makes routing more enjoyable by keeping your shop cleaner.



## 8 Guard Against the Bit

When you're focused on making a cut at the router table, it's all too easy to end up with your fingers too close to the bit. That's why it's a good idea to install a bit guard, like the one in the photo at right. The guard provides a constant reminder of where the bit is and where not to put your fingers.

The bit guard I like to use is just a tinted piece of shatter-proof plastic. I picked up the high-visibility model shown (715005) at the *Woodsmith Store* for about \$16. But you can find similar guards from other sources. (Refer to Sources on page 51.)

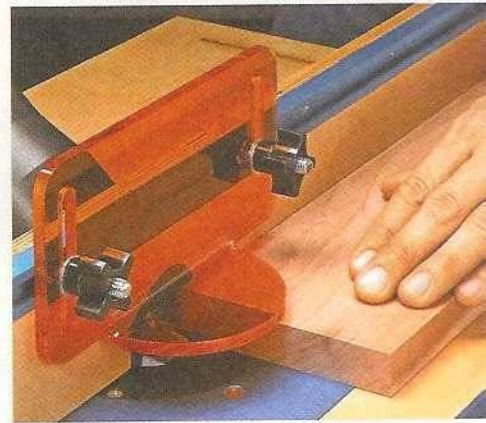

▲ **See-Through Guard.** Using a clear, plastic bit guard is a constant reminder to keep your fingers away from the bit.



▲ **Get a Grip.** Besides keeping your fingers away from the bit, a pair of push blocks provide a grip on your workpiece that can't be beat.

## 9 Push Blocks for Safety

A bit guard attached to the fence is one way to ensure your fingers don't inadvertently find their way into a cutting edge. Another good way to keep them safe is to use a pair of push blocks.

**Pressure & Security.** A pair of push blocks allow you to apply firm, even pressure to a workpiece. At the same time, they prevent injury by keeping your hands away from the bit, as you can see in the photo at left.

For a long time, I used an old grout float as a push block. But its large size and handle shape weren't always comfortable to work with—especially when I was working with a small workpiece. So I switched to

a pair of *Shop Fox* push blocks, like the ones you see at right.

The bottom of the push block has a soft foam facing to grip the workpiece securely. And the angled handles place your hands in a comfortable position to apply pressure down and into the fence. This lets you focus on the cut—not the grip you have on the workpiece.

Push blocks are cheap insurance, so it makes good sense to keep a couple on hand. The pair from *Shop Fox* were \$10. (Refer to page 51 for sources.)



▲ **Great Design.** The angled handles of these push blocks provide a secure, comfortable grip.

## 10 Accuracy with a Set-Up Gauge

One of the biggest challenges when using a router table is accurately setting the height of the bit and the position of the fence. Sure, you can use a metal scale to try to get things right where they need to be. But I've found that I get the best results with a set-up gauge.

**Dual-Use Gauge.** A number of manufacturers make gauges for setting the height of a router bit. But they aren't very handy for positioning the router table fence. That's why I prefer to use a dual-purpose gauge, like the one you see at the far right.

This gauge features a pair of legs that span wide insert plate and fence openings. Plus, there's a hairline indicator for taking accu-

rate measurements. A handy lock knob fixes the scale in place so you can remove the gauge for easy reading. This also makes it simple to return the fence (or bit) to a previous setting.

**Using the Gauge.** Although using a set-up gauge isn't too tricky, there are a couple things to keep in mind. First, be sure the scale is set against the cutting edge of the bit, as in the main photo. And second, the gauge measures to the *outside* edge the bit, so allow for this when setting the fence. 🛠️

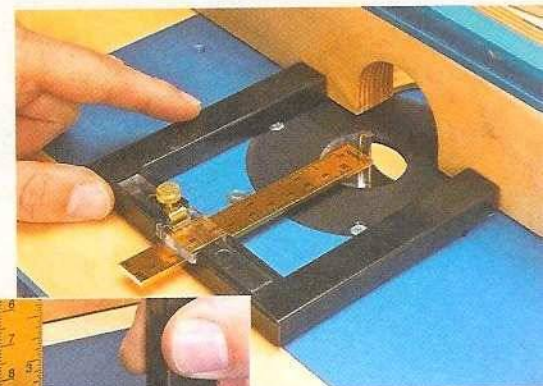

◀ **Dual-Use.** With the gauge standing upright, setting the height of a router bit is a snap.



# precision Miter Bars

Add these miter bars to your own jigs and adjust them for a perfect fit.

■ In the past when I made jigs for the shop, like the miter sled on page 34, I used to make my own miter bars (see box on the opposite page). But it was hard to get that perfect fit in the miter slot. Sometimes they were too tight and at other times, they were too loose. So I was looking for something a little better. After-market miter bars proved to be the answer.

I looked at four different miter bars from *Kreg*, *Inkra*, *Rockler*, and *Woodhaven* (see *Sources* on page 51). As you can see in the photos, they're all a little different.

## ADJUSTABILITY

A miter bar needs to slide easily in the miter slot. But, if it's too loose, your jig won't be very accurate. And if it's too tight, it's hard to use. You're looking for just the right "feel" where it's snug but slides with little effort.

To start with, you'll find that these miter bars are slightly undersized for a  $\frac{3}{4}$ " miter slot. That's so you can adjust them to fit snugly in your saw using one of the following methods for adjustment.

**Set Screws.** *Kreg* and *Woodhaven* use nylon set screws as shown in



▲ *Kreg*. Use an Allen wrench to turn the nylon set screws in or out to fine-tune the fit in your miter slot.



▲ *Rockler*. Spring-loaded ball plungers automatically adjust to fit the miter slot.



▲ *Woodhaven*. A small screwdriver is all that's needed to adjust the nylon set screws.



▲ *Inkra*. A unique wedge system flexes the sides of the miter bar as you adjust it from the top.



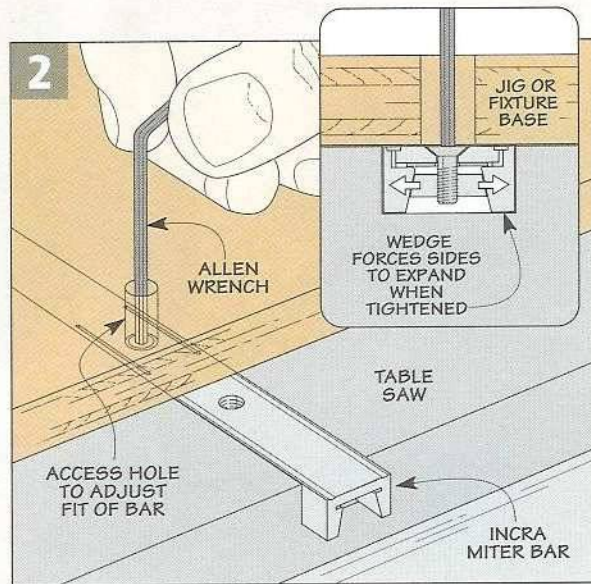
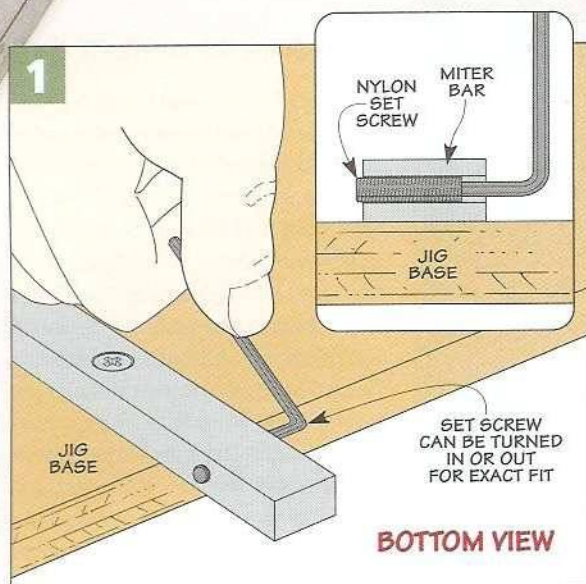

the photos on the previous page. The screws fit into threaded holes in the sides of the bars (Figure 1).

To adjust the fit in your miter slot, insert the set screws until they just start to project out the other side. Then start at one end of the bar and adjust each screw as you slide the bar into the slot. Here, you're looking for that perfect feel where there's no side-to-side play.

**Ball Plungers.** *Rockler* uses a different approach for adjustment. It uses spring-loaded ball plungers screwed into one side of the miter bar (see photo on opposite page).

In theory, the spring action keeps the bar snug in the slot. But I found that I could easily overcome the force of the spring and move it from side to side. You can make minor adjustments, but not enough to avoid the problem entirely. Be sure to consider this if you're looking for a lot of accuracy from your jig.

**Wedges.** When I opened the package for the *Inkra* miter bar, I was a little surprised. Instead of a solid aluminum or steel bar like the others, it's a machined piece of aluminum extrusion.

As you can see in Figure 2, they use a unique method for width adjustment. On the bottom of the bar are wedge-shaped nuts. When the adjustment screw is tightened from above, the wedge forces the sides of the bar to expand. It doesn't take much to get a nice fit.

A slight turn of the adjustment screw makes a big difference.

This "wedging" action has another benefit that you won't find in the other miter bars. You can actually tighten the bar to prevent it from moving at all. This allows you to build jigs that you can position in the miter slot, then lock down. Featherboards and clamping jigs come to mind.

### MOUNTING OPTIONS

I found that all of these bars are easy to attach to a jig. They feature

countersunk holes on the bottom for flathead screws. On all the miter bars except the *Kreg*, these holes are also threaded. That allows you to mount the bars with machine screws from the top of a jig for more flexibility.

For my quick-and-dirty one-use jigs, I'll still sometimes make my own miter bars. But since these after-market bars range in price from \$15 to \$30 you may want to order a couple extras to keep on hand. Their convenience and adjustability can't be beat. 🛠️

## Shop-Made: Miter Bars

When I'm in the middle of a project and need a jig in a hurry, a shop-made miter bar will do in a pinch. It's easy to make your own with materials you can keep on hand.

**Wood.** For a quick miter bar, make one from your wood scraps. To minimize swelling and shrinking that occur with changes in humidity, stable hardwoods are best. Choose quartersawn stock if you can. It won't change in width much with changes in humidity levels in your shop.

**Aluminum.** You can buy  $\frac{3}{8}$ " x  $\frac{3}{4}$ " aluminum bar stock. It's soft enough that you can drill and file it. Once you get a good fit in the miter slot, there should be little need to adjust it later.

**UHMW.** This durable, easy-to-work plastic is also available in  $\frac{3}{8}$ " x  $\frac{3}{4}$ " stock. It's low-friction, so it's ideal for miter bars. You can fine-tune the fit for your miter slot using woodworking tools.

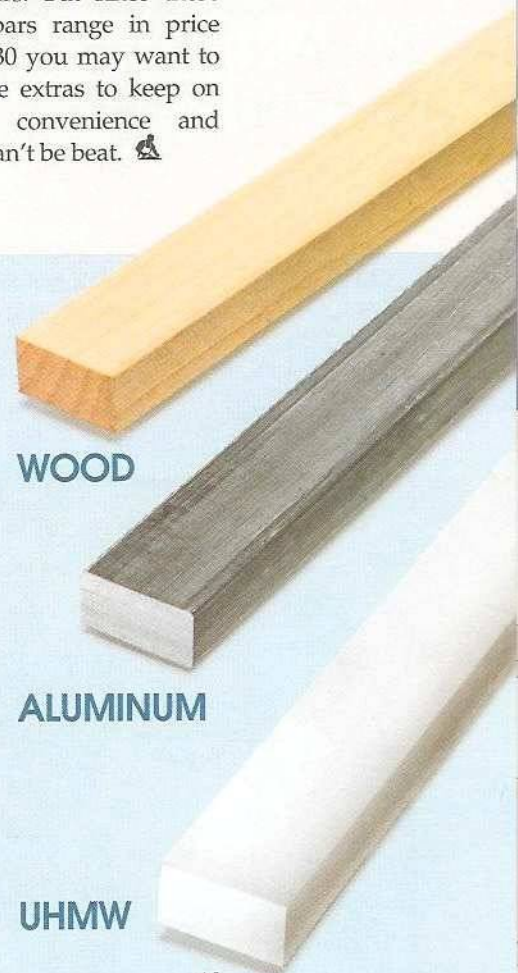



## all about **Brad Point Bits**

All brad point bits aren't the same. Find out what you need to know to get the best results.

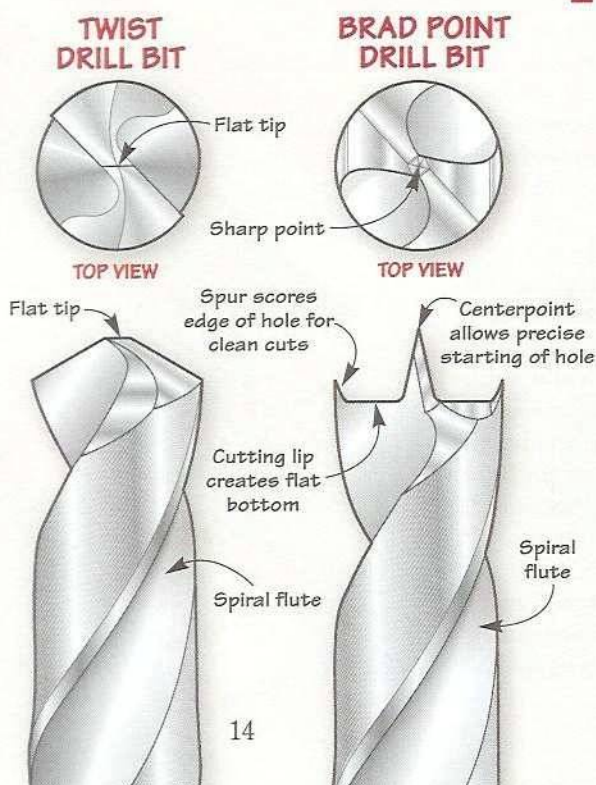

### DRILL BIT ANATOMY

At first glance, you'll notice that a brad point bit looks very similar to a standard twist bit. They both have a straight shaft with sharp, spiral flutes to pull the chips up out of the hole. In fact, some brad point bits start out as regular twist bits, then the tip is reground to a different shape. And it's this unique design at the tip of the bit that's the key to a smooth, clean hole.

**Getting to the Point.** Take a look at the drawing in the lower left corner of this page and you can see what I'm talking about. On the left is a standard twist bit. The end of the bit is ground at a shallow angle. And you'll notice that the very tip of the bit is almost flat.

Now, take a look at the brad point bit on the right. Here the tip of the bit is ground completely different. There's a very sharp center point, flat "cutting lips," and two "spurs" at the outside edge.

**Controlled Accuracy.** So what's all this mean when it comes to drilling a hole? Well, with a twist bit, as you start to drill, the bit wants to skate around on top of the workpiece. That's because a twist bit is designed for drilling into metal and the flat tip doesn't bite into the wood like you'd want.

When you use a good-quality brad point bit, the sharp center-point guides the bit into the workpiece. Then as the bit spins, the spurs score the perimeter of the hole, leaving clean, smooth sides and preventing tearout. Finally, the cutting lips act like revolving chisels. They pare away wood shavings within the scored perimeter. The end result — the bit doesn't wander and the edges of the hole are clean and crisp.

As you can tell, I'm sold on brad point bits. But open up a wood-working catalog and you'll find a wide variety of bits. Some cost a few dollars for a complete set while others cost several dollars for a single bit. Sorting it all out can be confusing. They're all brad point bits, so what's the difference?

Of all the bits that can be used to drill holes in wood, the brad point is probably the most versatile.

Chuck a brad point bit into a drill press and you'll get clean accurate holes in almost any type of wood. They can even be used to drill overlapping holes, which can make quick work of mortising.

However, you can't always use a drill press and that's where brad point bits have a big advantage — they work equally well in a handheld drill. This can be a real plus when you need to drill precise holes for installing hardware or adding shelf pin holes.

And finally, they come in a wide variety of sizes, so you can get exactly the hole size you need.

So what is it about a brad point bit that makes it so special?



## MAKING A CHOICE

Let's take a look at what you can get, starting with the least expensive bits.

**Bargain Bits.** Typically, there are two things that set bargain bits apart from higher quality bits — tip design and steel. If you look at the end of the bit, you'll notice that it lacks the spurs that score the perimeter of the hole. It's also missing the flat-ground cutting lip. Instead, the cutting lip is ground so it slopes up from the base of the center point to form a notch on each side. This forms a point on the edge of the bit that takes the place of the spur.

The problem is, the grind can be rough and these points dull quickly. So they have a tendency to dig into the wood causing tearout at the edges of the hole.

Another problem with bargain bits is that they're typically made from rather soft steel. This means they dull quickly and can start to burn. In fact, I've had new bargain bits turn the sides of a hole black from burning.

**HSS Bits.** For just a few dollars more, I find the high-speed steel (HSS) bits to be a better value. They're made from tougher steel and they stay sharp longer.

You'll find different styles of HSS brad point bits. The second photo on the right shows a production-style bit that's available from the *Fisch* company. Like the bargain bits, it has deep gullets that form points. But the grinding is very precise and at a steeper angle so the points are very sharp. But the centerpoint of the bit is beefier and has a flat edge, which can make it more difficult to center precisely.

My favorite style of brad point bit is one that has a conventional design. A long, sharp centerpoint, flat cutting lips, and sharp, scoring spurs (third photo). When you put all of that together in a HSS bit, you've got a bit that can drill clean, precise holes all day long.

**Carbide Bits.** Man-made materials, like MDF or melamine, can dull HSS bits with continued use. So if you plan on drilling a lot of holes in this type of material, you might want to consider getting a few carbide-tipped brad point bits. They'll last longer than HSS, the only down side is they're fairly of expensive. 🛠️

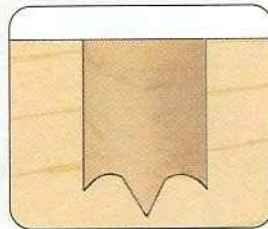

► Often made from soft steel with roughly ground points, bargain bits can cause burning and tearout.

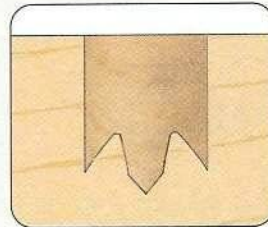

► Designed for production use, these bits feature extra-deep gullets and sharp points.

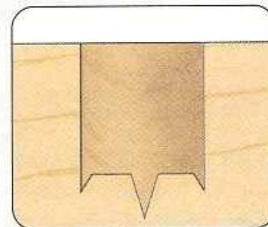

► A traditional brad point bit features a sharp centerpoint, flat cutting lips, and scoring spurs.

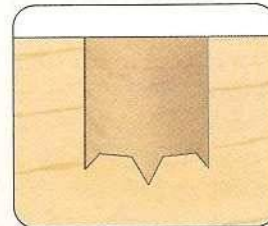

► While it's more expensive, adding a carbide tip means the bit will stay sharp for a long time.



**BARGAIN BIT**



**FISCH DESIGN**



**CONVENTIONAL DESIGN**

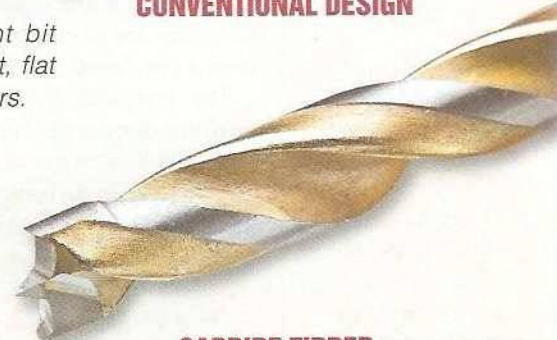

**CARBIDE TIPPED**

## Troubleshooting: Using Brad Point Bits

Here are some common problems you may experience when using brad point bits and how to solve them.

**Burning.** Typically, I'll experience burning when I'm using a bargain bit or a bit that needs to be sharpened. A newer or better-quality bit usually solves the problem. But if you have a good, sharp bit and it's still burning — try slowing down.

I've found the manufacturer's recommended speed for drill bits is too high. Often times the speed recommendations are for power boring machines, which is

way too fast for a drill press or hand drill. So I like to go with the slowest speed and I still get a clean hole.

**Tearout.** If you're experiencing tearout around the edge of the hole, you may be trying to feed the bit too fast. Here again, the solution is to slow down and let the scoring spurs do their job.

**Oversized Holes.** Occasionally, you may find a bit that produces an oversize hole. This usually only happens with poorly manufactured bargain bits. The only solution is to trade up to a new or better-quality bit.



# Shop Short Cuts

## Router Plate Installation

Whenever it comes to installing a router plate, the trick is always in sizing the opening to match the plate exactly. To make things easier when it came to installing the plate for the router table on page 18, I used a purchased template (see page 51 for sources).

The template is nothing more than a piece of medium-density-fiberboard (MDF) with an opening to match the size of the router plate. To use the template, all you have to do is tape it down to your router table top. Then using a pattern bit, rout a channel all around the edge of the opening. You'll want the depth of this channel to match the thickness of your plate.

Once you've routed the channel, remove the template and cut away the waste inside the opening with a jigsaw. Finally, you can smooth the rough edges of the opening by filing or sanding.

### ShopNotes

GO ONLINE EXTRAS

To learn how to install a router plate without a template, visit [ShopNotes.com](http://ShopNotes.com)

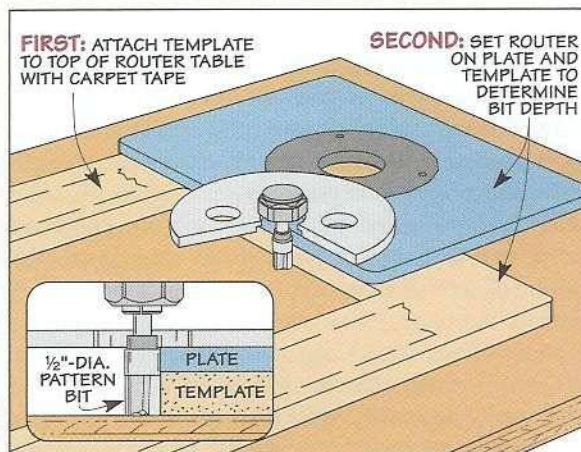

▲ **Set Bit Depth.** After attaching the template to your router table top with carpet tape, set the router plate on top of the template to determine the bit depth.

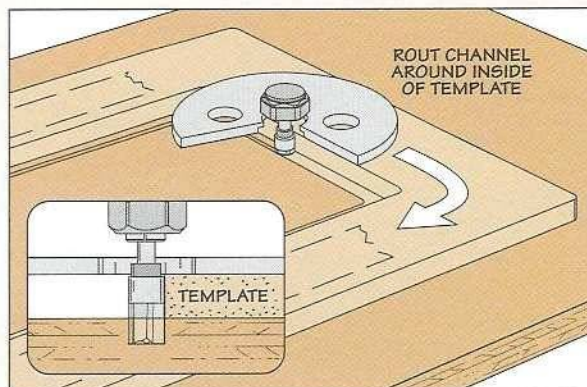

▲ **Rout Channel.** Next, set the router plate aside and using a 1/2"-dia. pattern bit, rout a channel all around the inside of the template.

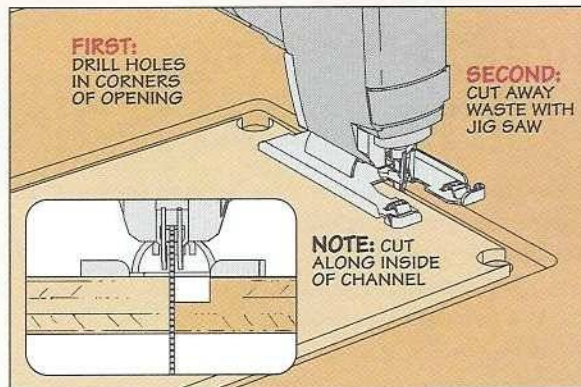

▲ **Cutting Out Waste.** To remove the waste from the center of the opening, drill a clearance hole in each corner. Then use a jig saw to cut out the waste.



## Attaching Fences to the Miter Sled

There's not much to attaching the fences on the miter sled on page 34. They're simply screwed in place. But getting each fence positioned at a perfect 45° angle on the first attempt is easier said than done. To make this task a bit easier, I used a pair of oversized holes for the screws that attach the fences. This allows you to "tweak" the position of each fence for a perfect 45° miter.

To initially position the fence, I used a plastic drafting triangle. (These triangles are inexpensive and surprisingly accurate.) I set the triangle against the blade guard and drew a line to indicate the position of the back edge of the fence. Then I attached the fence to the miter sled base with a pair of washerhead screws.

With the fence attached to the base, you can now check the position of the fence for accuracy. To do this, I made a couple of test cuts and then placed the test pieces together side by side. Now simply use a square to check the included angle (Figure 2). If the angle is 90°,

you know that fence is positioned at 45°. If it's not, you'll need to nudge the fence a bit and check the setting on a new set of test cuts.

Once you have the fence in position, you can tighten down the two washerhead screws (Figure 1a). Then to hold the fence securely, I

added three more screws from the underside of the base of the sled (Figures 1 and 1b).

With the first fence in position, you can now repeat the process to attach the second fence. Once you're done, both fences should be set up to cut perfect miters. 🛠️

1 FIGURE

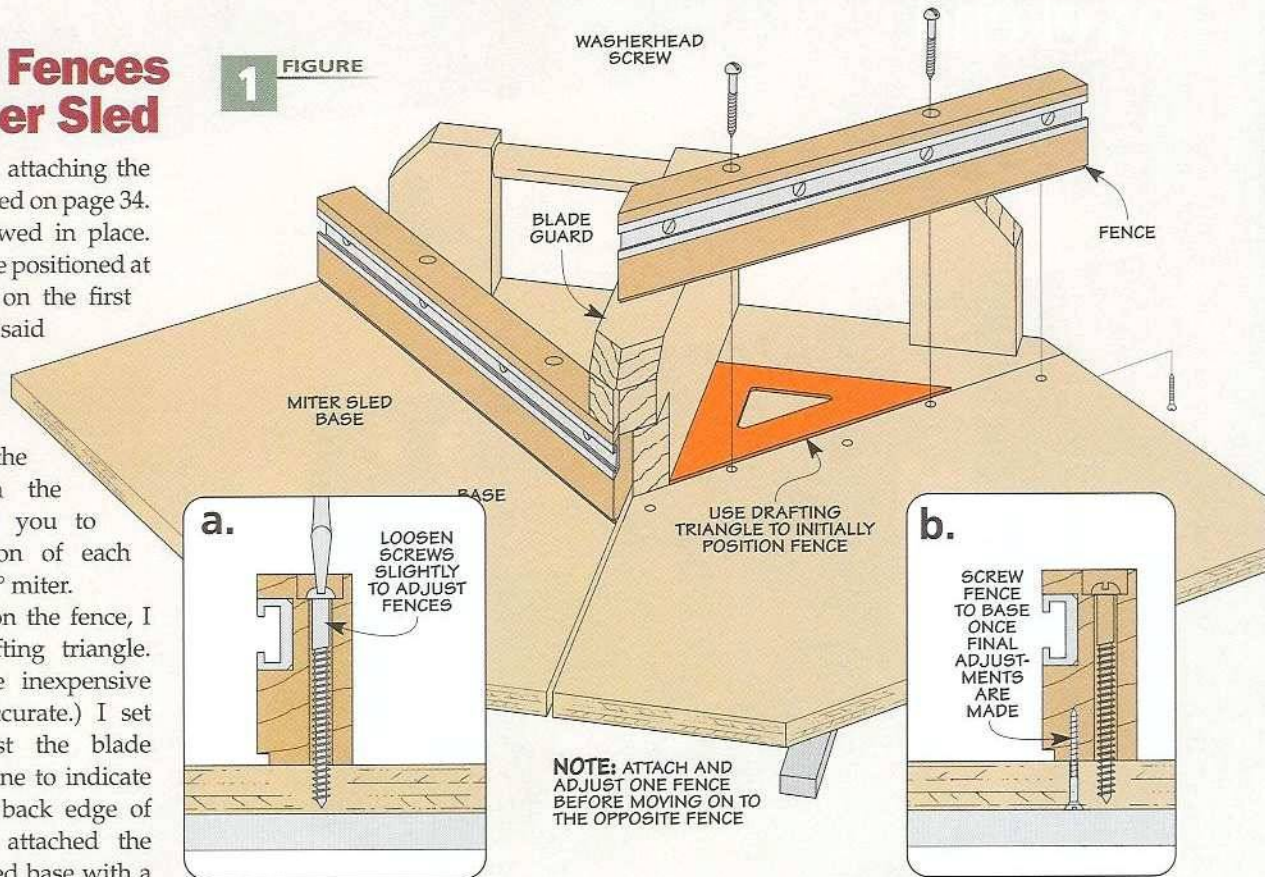

## Plywood Edge Drilling Guide

Installing magnetic catches is usually a pretty simple task — just drill a hole and screw the catch in place. But since the plywood in the hardware organizer on page 28 isn't much thicker than the diameter of the catches, I was concerned that I might actually blow through the side of the case while drilling the holes for the catches.

To solve this problem, I made a simple drilling guide out of a piece hardboard and a scrap of plywood (see photo). A hole in the block of the guide keeps the drill bit perpendicular while drilling the holes for the catches.

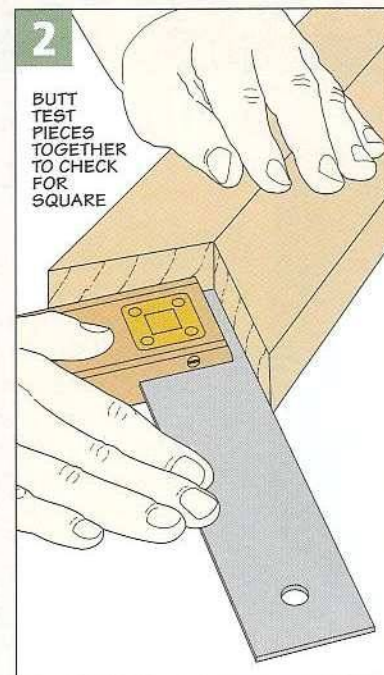



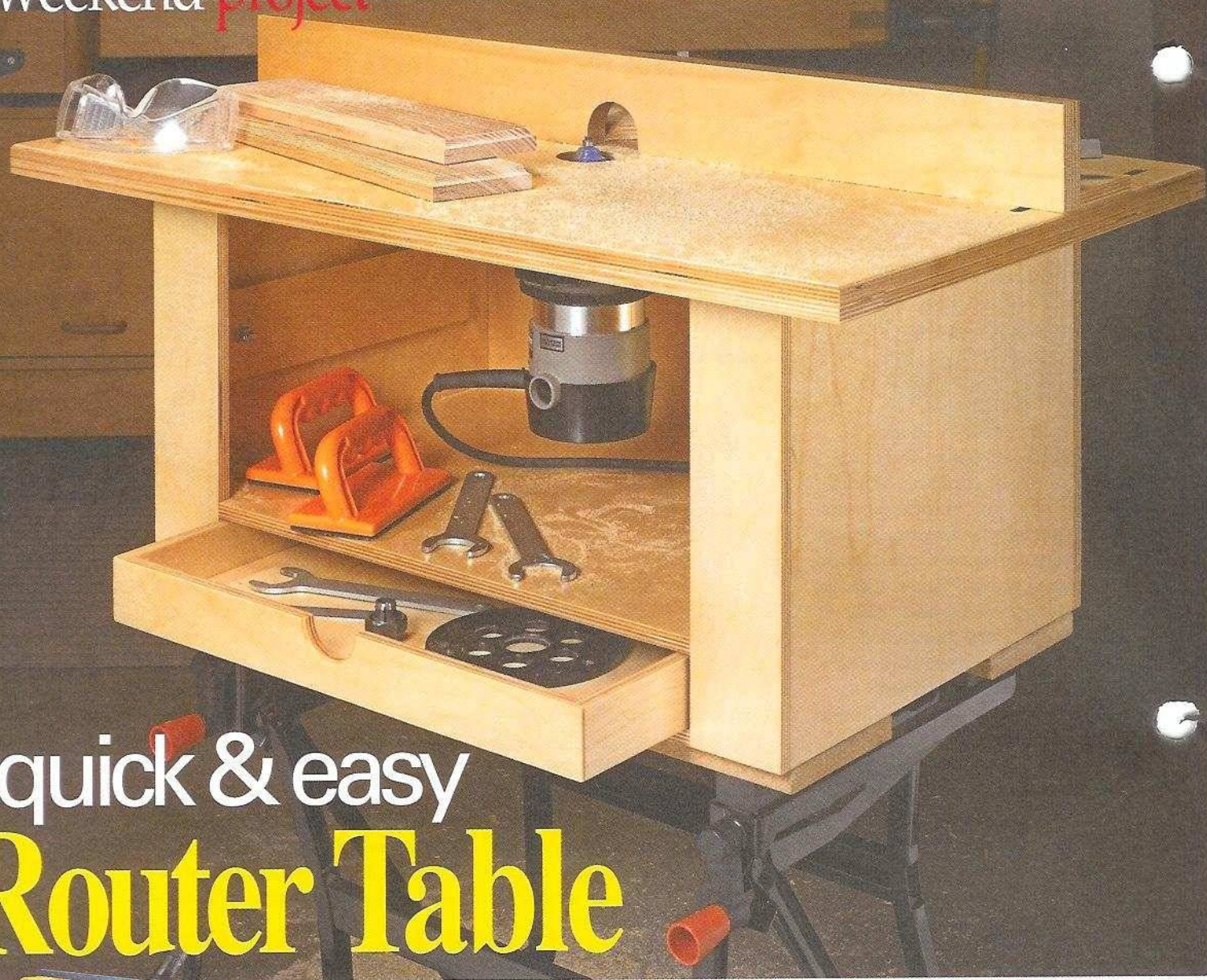

# quick & easy Router Table

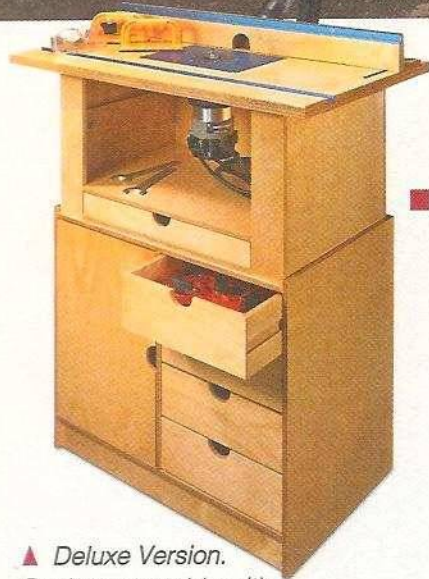

▲ *Deluxe Version.*  
Basic router table with  
upgrades and optional stand.

This simple table will get you going, later add a few options for even more capabilities.

■ This router table is packed with some impressive features. But what I really like about it is that it takes only one 5' x 5' sheet of 1/2" Baltic birch plywood (see the cutting diagram on the next page) and a weekend to build.

**Large Top.** Fast construction isn't the only thing going for this router table. For starters, the top is a full 20" x 32". But there's more to it than pure size, the top tilts up for easy router access. The heavy-duty fence makes accurate cuts a snap. And it adjusts quickly and locks securely to the tabletop.

**Simple Joinery.** The case, built with simple, no-frills joinery, can be quickly

clamped to a workbench or even sawhorses. And there's a drawer at the bottom for storing bits, wrenches, and other items.

**Upgrades and Add-ons.** From the beginning, this router table is designed to be upgraded and added on to without having to start over. For instance, you can add an optional stand with either adjustable shelves or a door and some drawers (photo at left).

The tabletop and fence are also ready for some extra features, like a miter track, a router plate and T-track. And to top it off, at least around here, you can pick up the sheet of plywood for around \$50.



# Exploded View Details

**ShopNotes**  
GO ONLINE EXTRAS

To download a free cutting diagram for the optional stand, go to: [www.ShopNotes.com](http://www.ShopNotes.com)

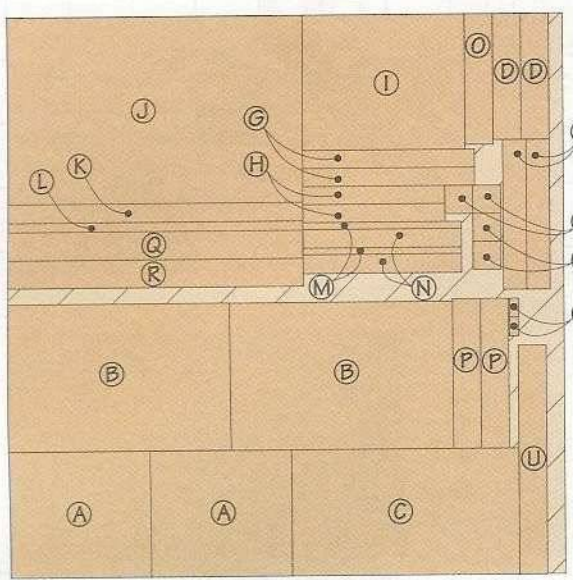

60" x 60" - 1/2" PLYWOOD

**CUTTING DIAGRAM**  
(ROUTER TABLE, TOP, AND FENCE)

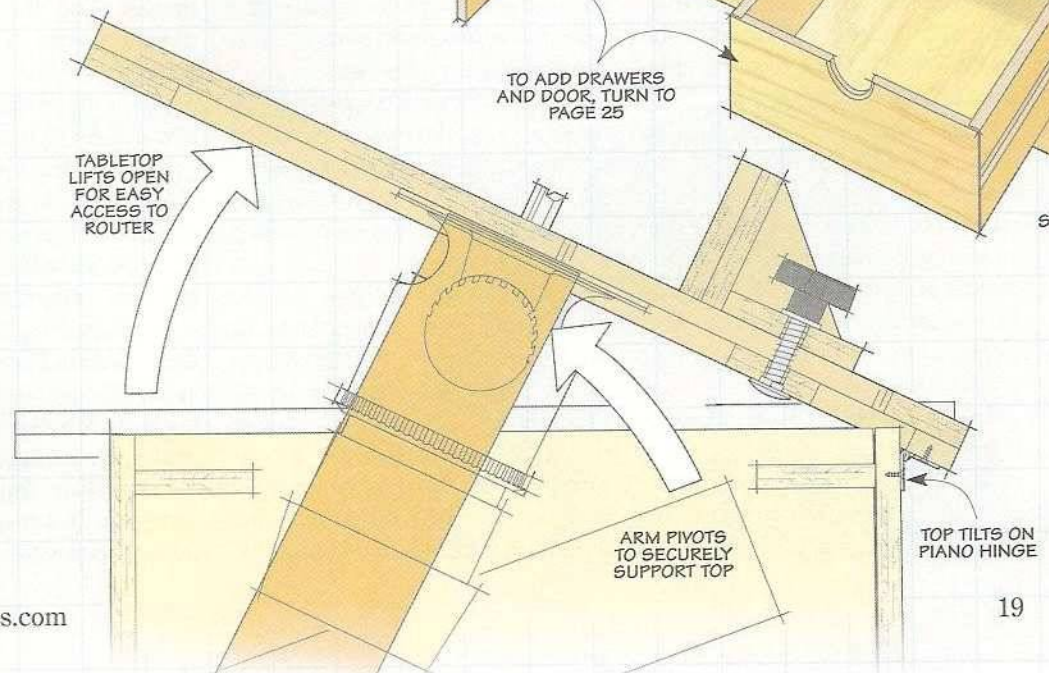
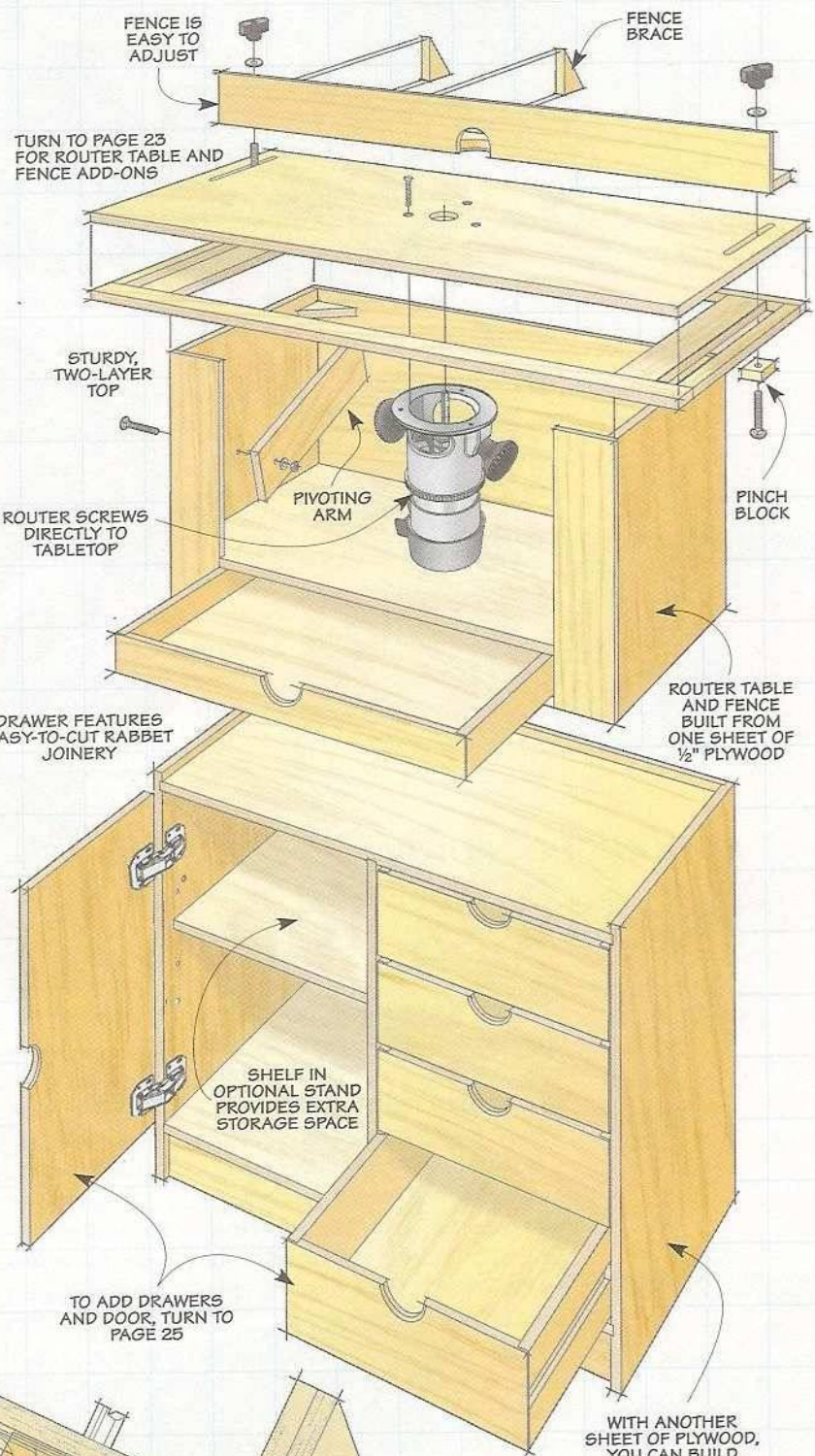



**1** FIGURE

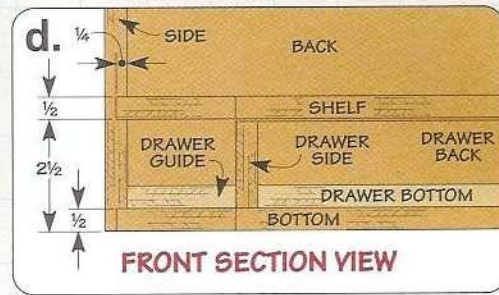
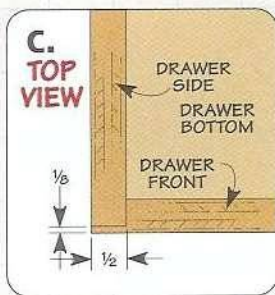
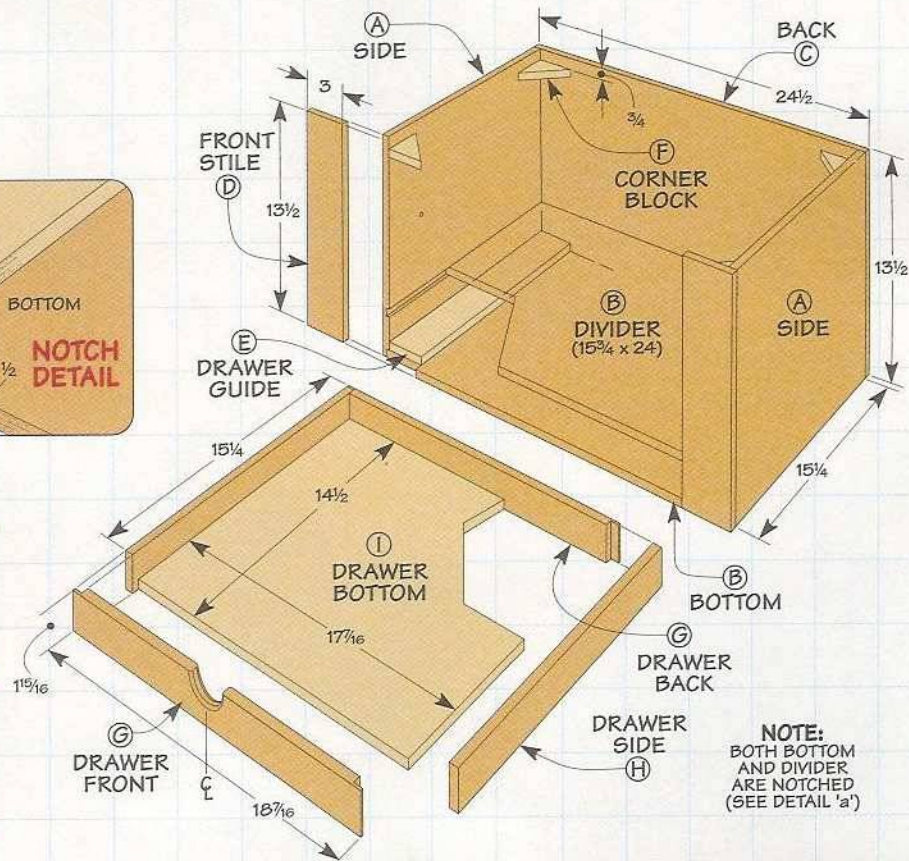
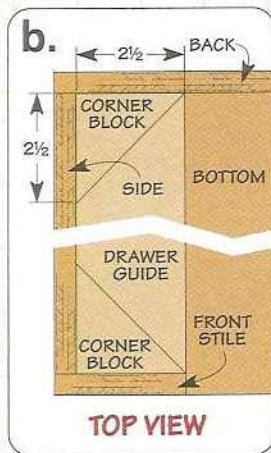
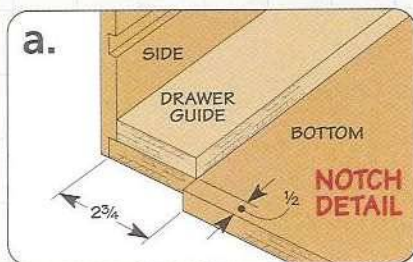

## strong and sturdy Case & Top

One of the goals I had when building the case of the router table was to make sure it could be built quickly. But it still needs to be strong enough for every day use.

**Straightforward Joinery.** As I mentioned earlier, the router table case uses sturdy plywood construction with dados and rabbets. The whole table is built from 1/2" plywood. (I used Baltic birch.)

**Sides First.** I began construction with the case sides. In Figure 1d, you can see that there's a dado and a rabbet cut in each side piece. This joinery locks a divider and the case bottom in place for a strong, wobble-free assembly. The divider also creates a pocket for the drawer that will be added later.

Before assembling the divider and bottom to the sides, I cut a 2 3/4"-wide notch at the front corners of each piece, as you can see in Figure 1a. This notch holds a pair of narrow

stiles that keep the front of the case rigid while still providing a large opening to get at the router.

The back is a simple plywood panel that's sized to overlap the sides. With these main parts cut, you can glue the case together.

**Corner Blocks.** The divider and case bottom make the lower portion of the case plenty strong. But since the tabletop isn't screwed to the case, the upper part of the case needed some reinforcement.

The solution I used here was to make four, angled corner blocks, as illustrated in Figure 1b. You can see in the main drawing that I positioned them 3/4" from the top edge of the case. The reason for this is simple. The hinged tabletop is designed to nestle down over the top of the case, so lowering the

corner blocks ensures that they won't interfere with the fit.

There are just two parts left to add to the case before moving on to the drawer. And those are a pair of drawer guides. They're cut to fit behind the front stiles to keep the drawer from binding in the opening, as shown in Figures 1 and 1d.

**Simple Drawer.** The drawer in the router table provides a place to store wrenches, bits, and other supplies. And like the rest of the router table, it's straightforward to build.

In the drawing above, you can see that a rabbeted frame simply wraps around the drawer bottom. The relatively thick bottom provides plenty of glue surface for a strong bond.

**Large, Flat Top.** With the case complete, I set it aside and turned my attention to the top, shown in the



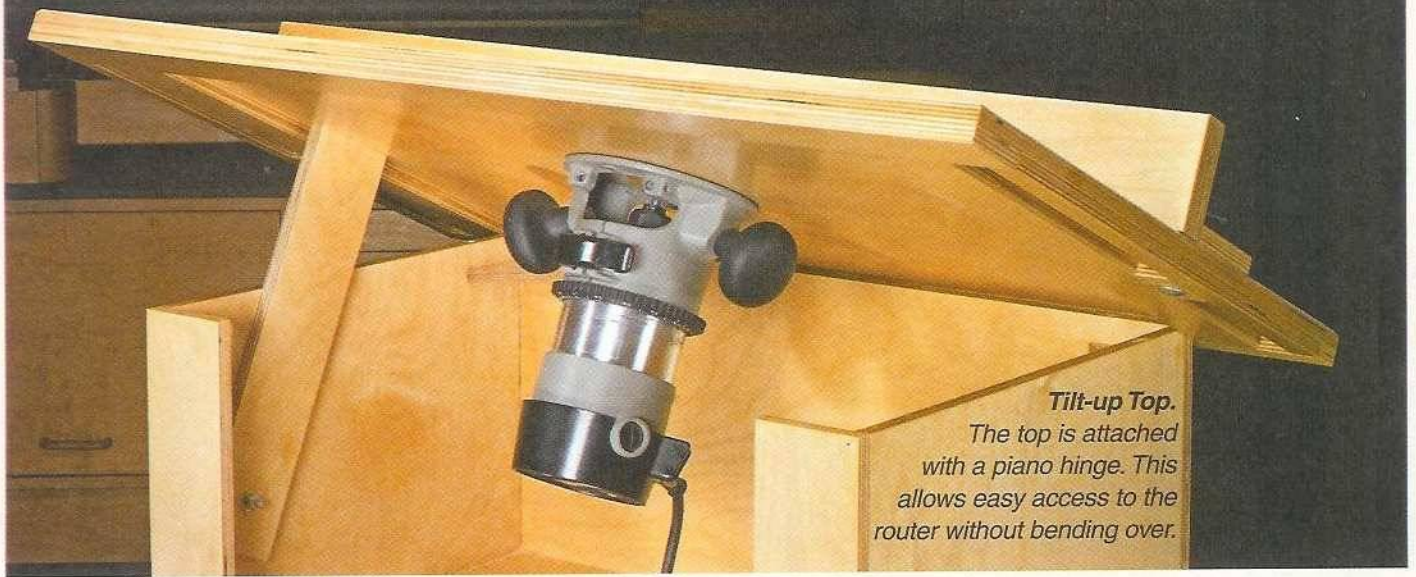

drawing below. Since this is where all the work will take place after the table is complete, the goal here is to make it flat and rigid.

Making a large top from plywood isn't a challenge — just cut it to size. But with  $\frac{1}{2}$ " plywood, you want to make sure it won't flex under the load of large, heavy pieces. So, to make this tabletop stay flat, it's reinforced around the bottom edge.

The top has a few openings cut into it. The center hole is where the router is attached to the table and

where the bit comes through. At 2" in diameter, it's big enough to handle most bit sizes.

The other two openings are a pair of slots that will be used to connect and adjust the fence that will be added later, as in Figure 2. To attach the router to the table, I simply screwed it to the top.

**Fillers and Braces.** As I mentioned, the top is strengthened with some cleats underneath it. Besides keeping the top from flexing, the cleats do one other thing. They are

positioned so that the top fits over the case like a lid, you can see this in Figures 2a and 2b.

**Tilt-Top Design.** Rather than screwing the top to the case, I attached it with a piano hinge along the back edge. This allows me to tilt up the tabletop and get at the router without having to stoop over.

Then, to hold the top open so I can use both hands, I bolted a prop arm to the inside of the case, as shown in the drawing and arm detail below.

**2** FIGURE

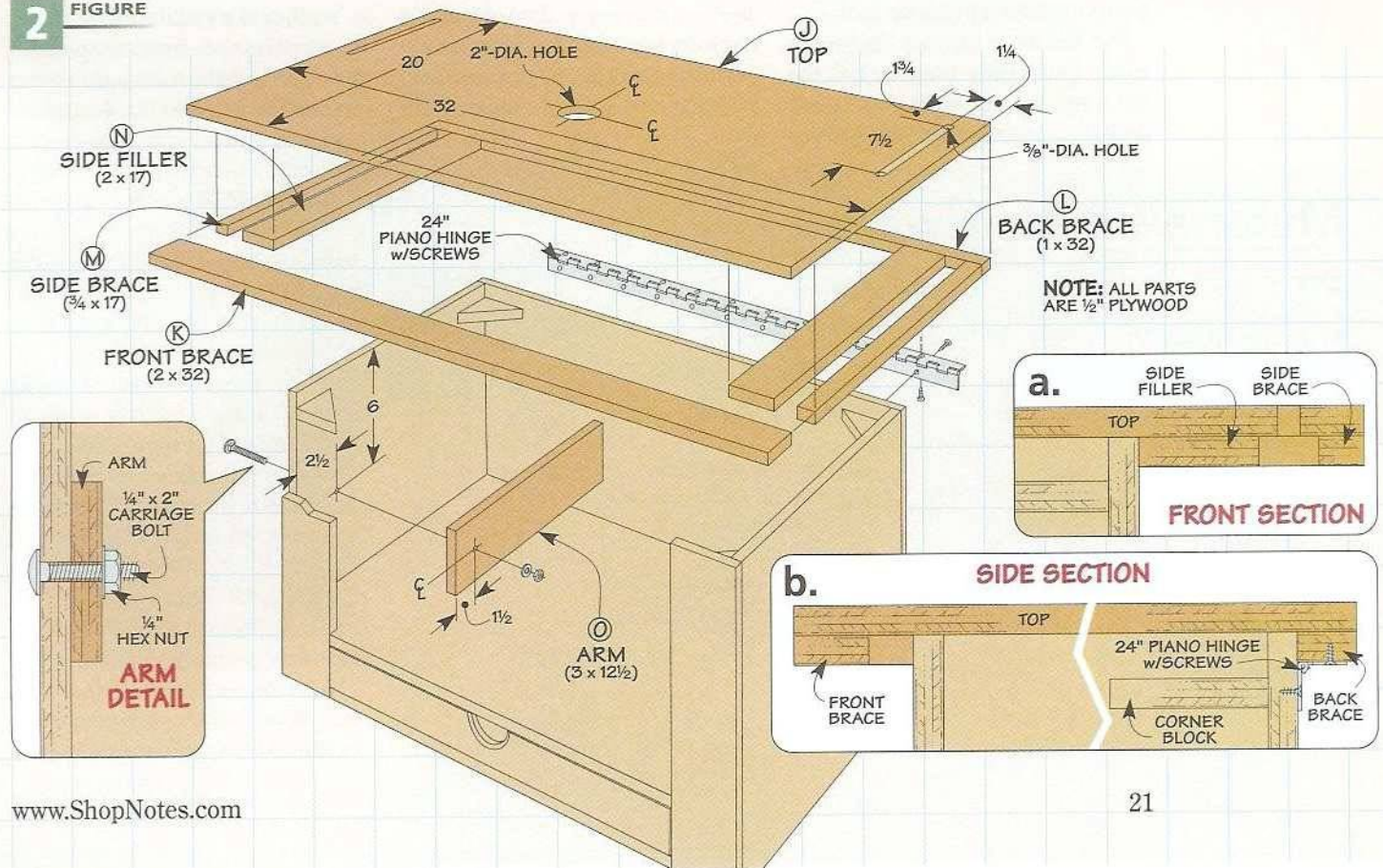



3 FIGURE

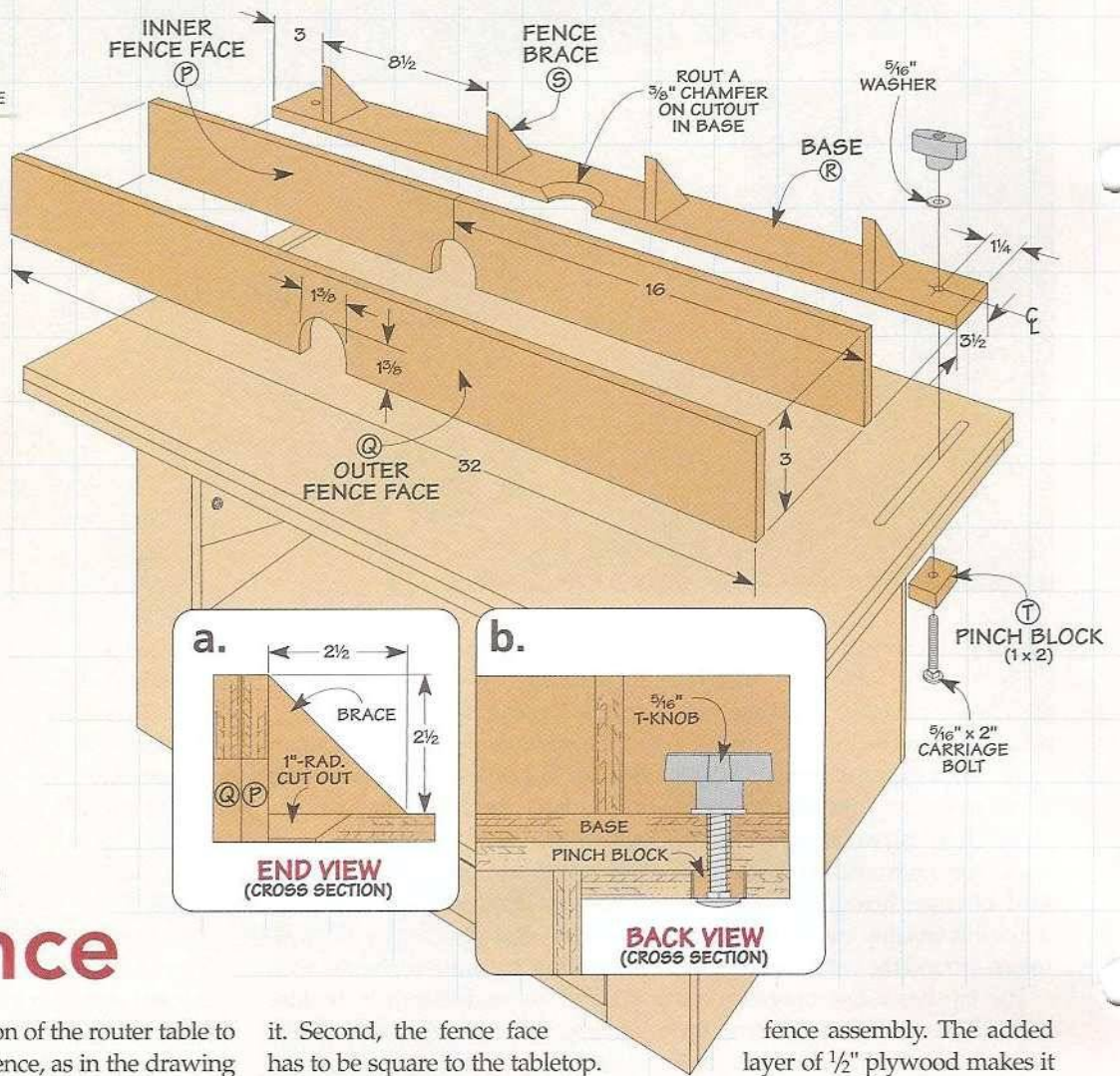

▲ Router Fence. Grooves in the router table allow you to easily position the fence and lock it securely to the tabletop.

## a precision Fence

The last section of the router table to make is the fence, as in the drawing above. And it's really what makes the router table a precision tool.

For the fence to work its best, it needs to do three things. First, the fence needs to be rigid so it won't deflect as a workpiece slides across

it. Second, the fence face has to be square to the tabletop. This way, you can be sure your cuts are accurate every time. Finally, it has to lock securely to the tabletop.

**Heavy-Duty Face.** The first step in building the fence is making the faces. Here, I used a double-layer

fence assembly. The added layer of 1/2" plywood makes it less likely to flex or warp.

You'll notice that the inside face of the fence is made from two pieces. I did this to get the most parts from a single sheet of plywood. A centered cutout in each layer is large enough to accommodate most router bits.

**Stable Base.** This assembly is then glued to a base that has a matching cutout. To help dust and chips clear this opening, I routed a chamfer on the cutout in the base (Figure 3a).

The joint between the fence and the base needed some reinforcement. I did this by gluing braces to the backside of the fence face.

**Attaching the Fence.** The fence is connected to the table with carriage bolts, washers, and knobs. The carriage bolts run through a pair of pinch blocks. These slide in the channel created by the reinforcing cleats on the bottom side of the table.

Now, the router table is ready for use. But on the next page, you'll find some options to get more out of it.

## Materials & Hardware

### CASE

A Sides (2)	13 1/2 x 15 1/4 - 1/2 Ply.
B Bottom/Divider (2)	15 3/4 x 24 - 1/2 Ply.
C Back (1)	13 1/2 x 24 1/2 - 1/2 Ply.
D Front Stiles (2)	3 x 13 1/2 - 1/2 Ply.
E Drawer Guides (2)	13 1/2 x 2 1/2 - 1/2 Ply.
F Corner Blocks (4)	2 1/2 x 2 1/2 - 1/2 Ply.

### DRAWER

G Front/Back (2)	1 15/16 x 18 7/16 - 1/2 Ply.
H Sides (2)	1 15/16 x 15 1/4 - 1/2 Ply.
I Bottom (1)	14 1/2 x 17 7/16 - 1/2 Ply.

### TOP

J Top (1)	20 x 32 - 1/2 Ply.
K Front Brace (1)	2 x 32 - 1/2 Ply.
L Back Brace (1)	1 x 32 - 1/2 Ply.
M Side Braces (2)	3/4 x 17 - 1/2 Ply.
N Side Fillers (2)	2 x 17 - 1/2 Ply.
O Prop (1)	3 x 13 - 1/2 Ply.

### FENCE

P Inner Faces (2)	3 x 16 - 1/2 Ply.
Q Outer Face (1)	3 x 32 - 1/2 Ply.
R Base (1)	3 1/2 x 32 - 1/2 Ply.
S Braces (4)	2 1/2 x 2 1/2 - 1/2 Ply.
T Pinch Blocks (2)	1 x 2 - 1/2 Ply.

- (1) Nickel-plated piano hinge w/Screws
- (1) 1/4" x 1 1/4" Fh Woodscrews
- (1) 1/4" Flat Washer
- (1) 1/4" Lock Nut
- (2) 5/16" x 2" Carriage Bolts
- (2) 5/16" Flat Washers
- (4) 5/16" T-Knobs



# router table Upgrade

There isn't much you can't do with the basic router table and fence. But you can make it work even harder and more efficiently with a few, simple upgrades (photo at right). The best part is, you can build the tabletop, top, and fence, as shown in the plans and then add any or all of these upgrades at a later time.

**Router Plate.** The tilt-up tabletop makes it easy to get at the router. But you can make router access even easier with a mounting plate. This is especially handy for bit changes and removing the router for hand-held use.

The router plate shown in the photo above also has drop-in insert rings. They let you match the size of the opening to the size of the bit. The plate rests in a rabbeted opening in the top. You can read more about installing it on page 16.

**Miter Track.** Another tabletop addition is a miter gauge slot. With

► **Easy Upgrades.** A miter track, router plate, and T-track add versatility to the router table.

this, you can use a standard miter gauge on your router table to rout the ends of narrow workpieces. The only thing to note here is that you'll need to add a reinforcing strip to the underside of the table, as shown in detail 'b.'

**T-track.** On the fence, there are two upgrades that really make a big impact. The first is to add T-track along the top edge. With this,

attaching bit guards, featherboards, and stop blocks is a snap.

**Dust Collection.** The final addition is to screw a dust collection port to the back of the fence. This is a big way to improve visibility and clear the shop air, as shown in detail 'a.' Turn to page 51 to find sources. You can find other router table accessories on page 8.

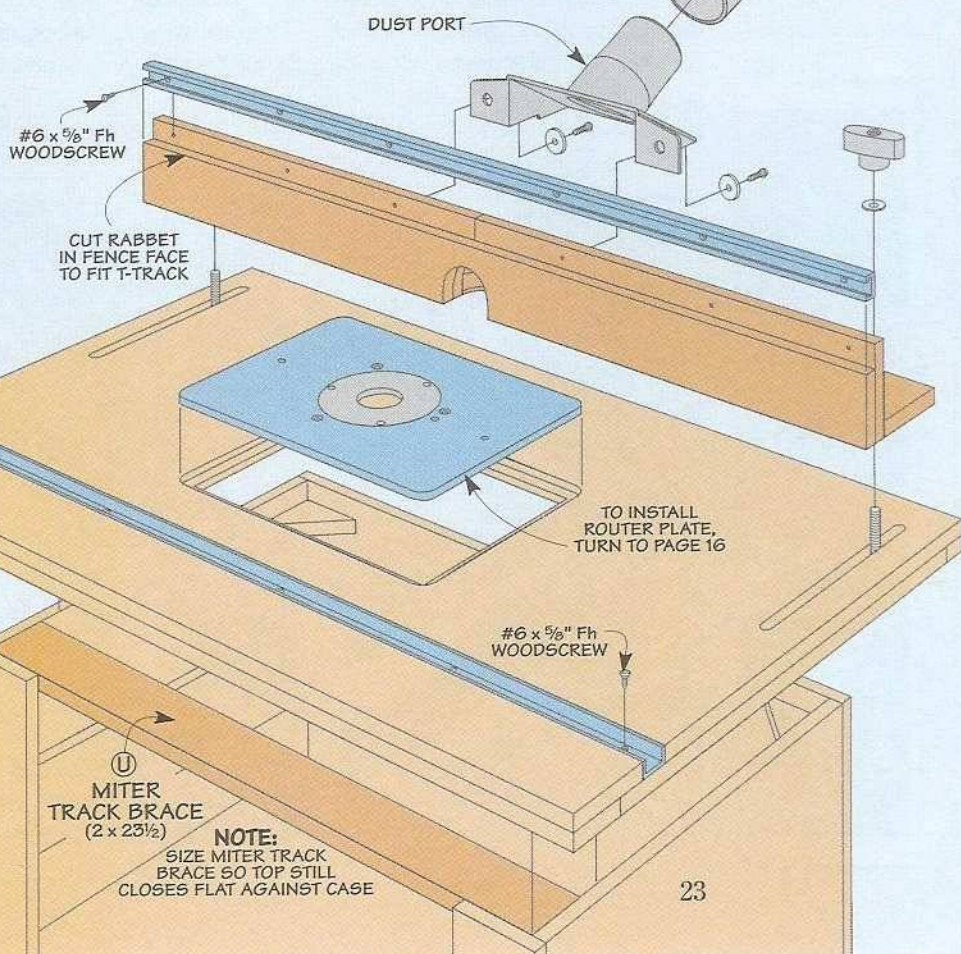
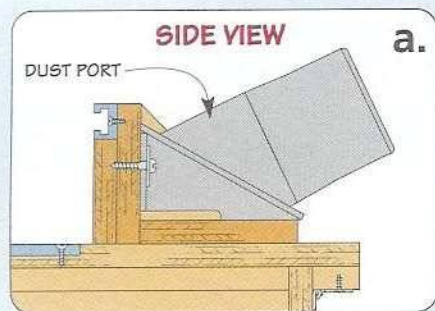
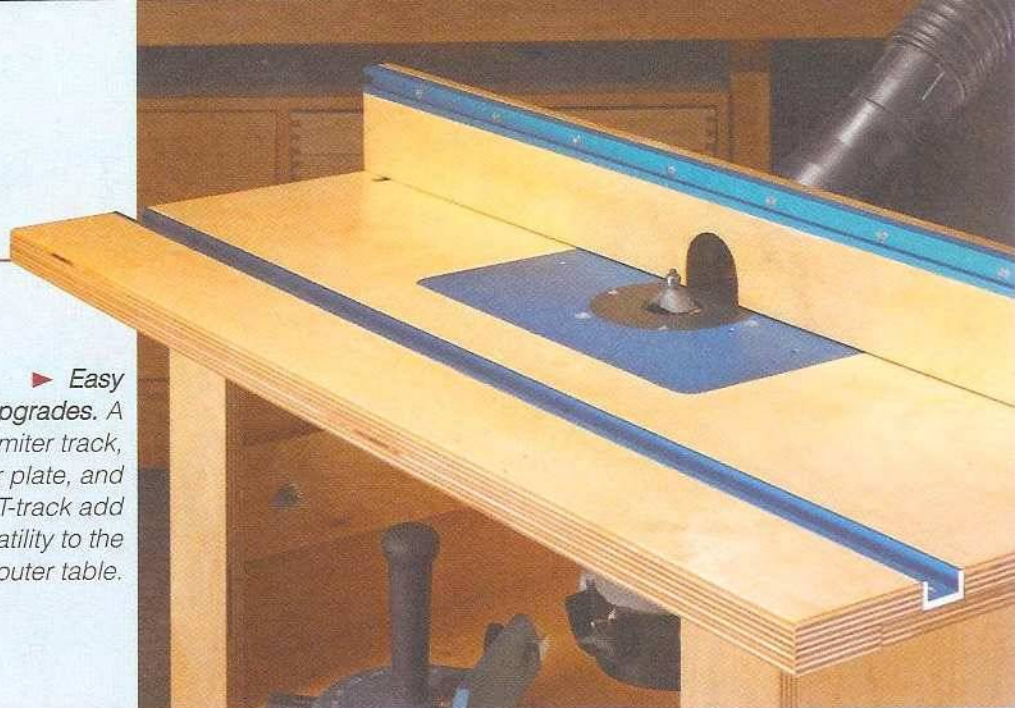

NOTE: FOR MORE ON DUST COLLECTORS SEE PAGE 8

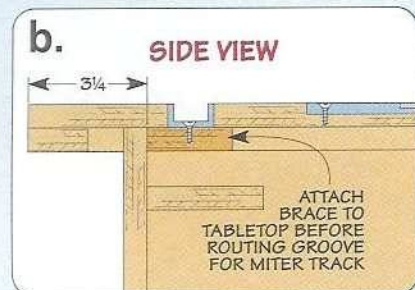



# optional tool Stand

There's nothing stopping you from putting the router table to use just the way it is. And it's small size makes it portable enough to take to a job-site. But for routing in the shop, it might make sense to have a dedicated stand like you see in the photo at right. This simple stand captures the router table in a ledge around the top and places the tabletop up to a comfortable height. And you'll gain some valuable storage space.

You'll find the process of building the stand pretty similar to the router table. And like the router table, the stand only requires a single sheet of 1/2" plywood.

**Case Sides First.** To build the stand, I started by cutting the sides to size. These have two dados cut in them to hold the top and bottom panels (Figure 4b). And a rabbet cut along the back edge of each side holds the case back in place.

Next, I cut the top and bottom panels to size. These have a centered dado that captures a vertical divider. After dry assembling the



sides, top, and bottom, you can double check the measurements for the divider and cut it to fit.

To reinforce the bottom of the case, I made a toe kick and a pair of cleats to fit under the case bottom. The last thing to do before assembling the case is to cut a back to fit

between the rabbets in the case sides, as shown in Figure 4a.

**Shelves and Supports.** There are just a couple details left to wrap up the stand. I cut three shelves to size. And finally, I drilled a set of shelf pin holes in the sides and divider to support the shelves.

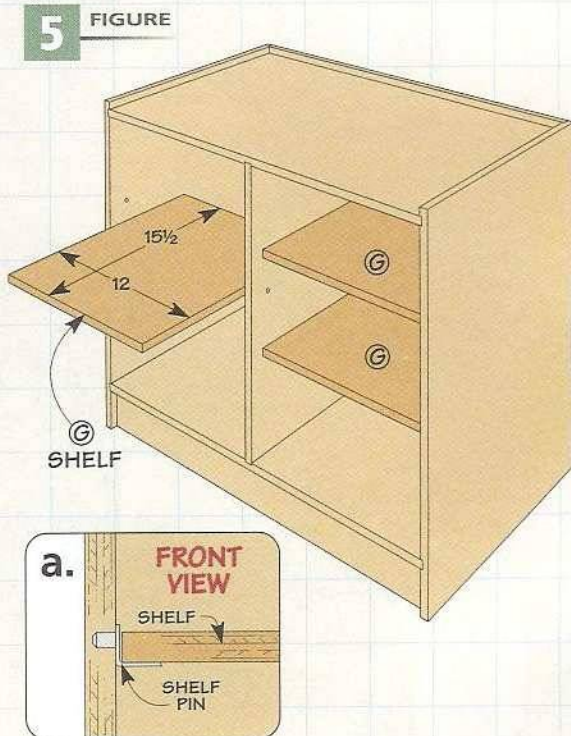
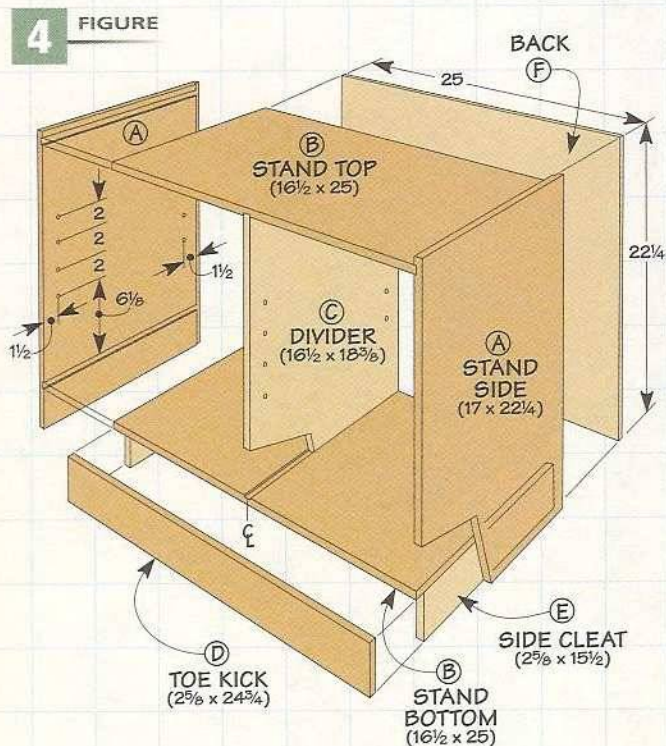
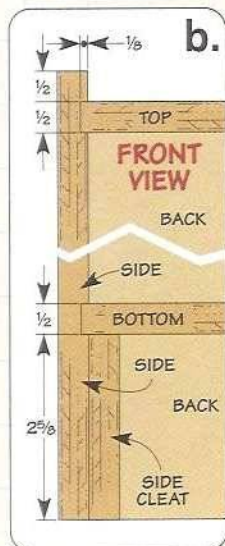
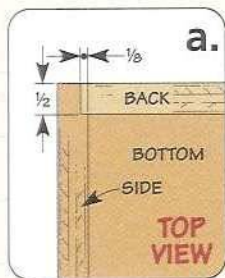



# Upgraded Stand

It's pretty amazing that you can build the stand shown on the opposite page from a single sheet of plywood. And not only does it raise the router table up to a comfortable working height, it adds a lot of storage for the accessories that routers tend to accumulate.

But like the tabletop and fence, you can also take the stand up a notch. And all it takes is another sheet of  $\frac{1}{2}$ " plywood. You can see what I added in the drawing below and the photo at right. At first glance, making a few drawers and door may not seem like a big improvement, but I found that it was more than worth the effort.

With the drawers, you can easily find and get at the small tools, bits, and accessories that usually find their way to the back of the shelves. Another benefit of the drawers and door is that it blocks out dust.

**Making the Door.** The door is about as easy as it gets. It's simply cut to size and then a cutout is made for a handle. The door is mounted on self-closing hinges.

**Drawers.** The drawers in the stand follow pretty much the same construction as the small drawer in the



router table. But there's an important differences. The drawers ride on thin guides that are cut from plywood and screwed to the stand (detail 'd' and drawer guide detail). The guides fit in grooves that are cut in the drawer sides before assembly. Finally, a matching notch is cut in the drawer back in order for the drawers to slide in place, as illustrated in detail 'c.'

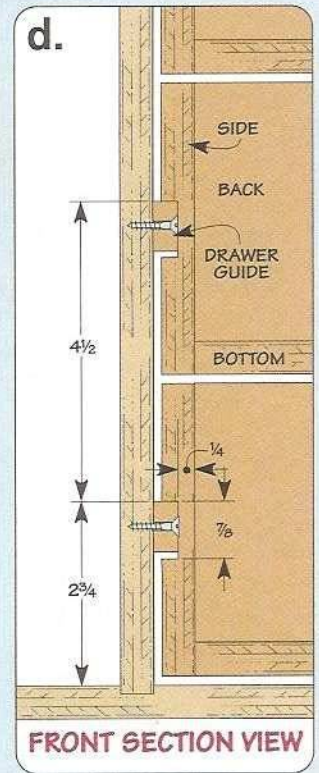
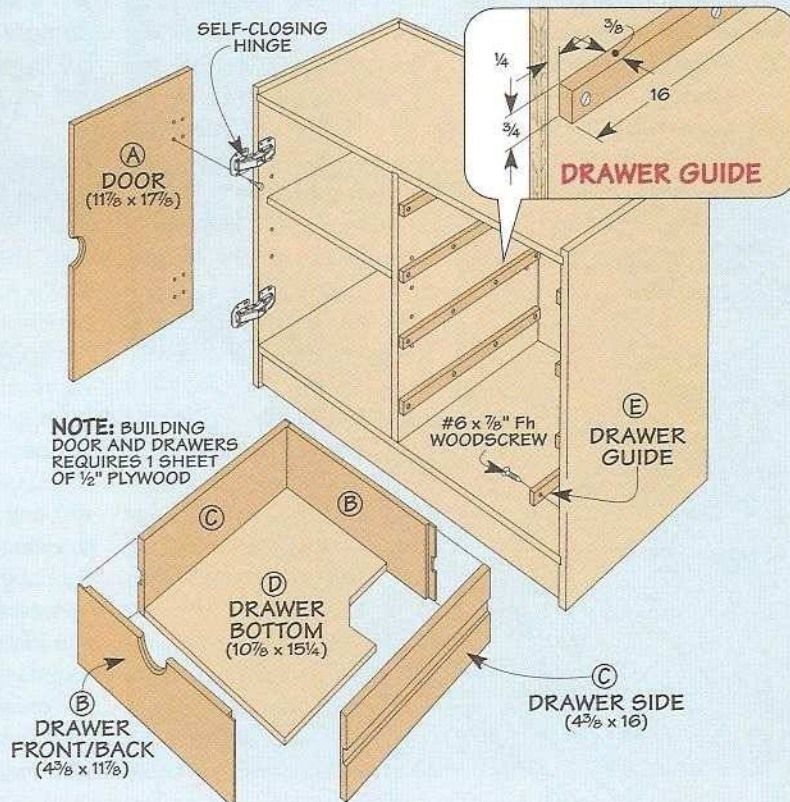
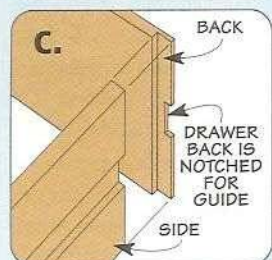
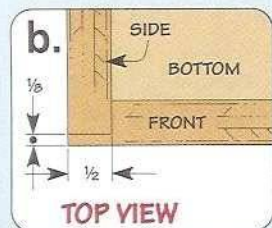
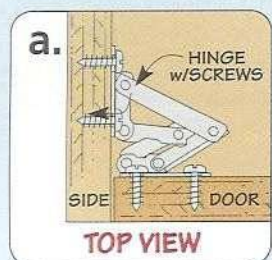



# no-fuss drawers on the **Router Table**

Three easy steps and a single bit — that's all it takes to quickly build strong drawers.

The next time you need to build a lot of drawers — especially small drawers — you might want to consider using a tongue and dado joint. This strong, no-fuss joint makes quick work of building drawers.

The nice thing is, there are no tricky setups to making this joint.

All it takes are the three easy steps — dados, rabbets, and grooves —

shown on the next page. And best of all, what makes this joint even better is that you can cut it entirely on the router table — using only a  $\frac{1}{4}$ "-dia. straight bit.

**Preparation.** Before heading over to the router table, it's a good idea to cut all the drawer parts you'll need (plus a few extra test pieces for setting up the bit and fence). I use  $\frac{1}{2}$ "-thick stock for the drawer front, back, and sides. This way, you can then perform each step in an assembly-line fashion.

**Dado First.** First, you'll rout dados in the drawer sides. Here, I like to use a backerboard, like you see in the photo above. It does two things for me. For one, it prevents chipout in the cross-grain cut by supporting the back edge of the piece. Second, the backerboard helps keep the narrow workpiece square to the bit for a straight, accurate cut.

**Next, a Rabbet.** The second step in the



▲ **One-Bit Drawers.** Use a  $\frac{1}{4}$ " straight bit to rout flat-bottomed dados, rabbets, and grooves for this simple drawer joint.

process is routing rabbets on the drawer front and back. Here again, you'll want to use a backer to prevent chipout. The result is a box that's square, and the front and back are flush with the sides.

**Grooves Last.** With the corner joints taken care of, the final step is routing a groove for the drawer bottom. This groove will leave visible gaps in the front and back of the assembled drawer, as in the drawing at right. But you'll take care of that in the assembly stage.

**Assembly.** Once the joinery is complete, you can fit the parts together and slide the plywood bottom in place. After attaching a false front to conceal the ends of the grooves, you're done.

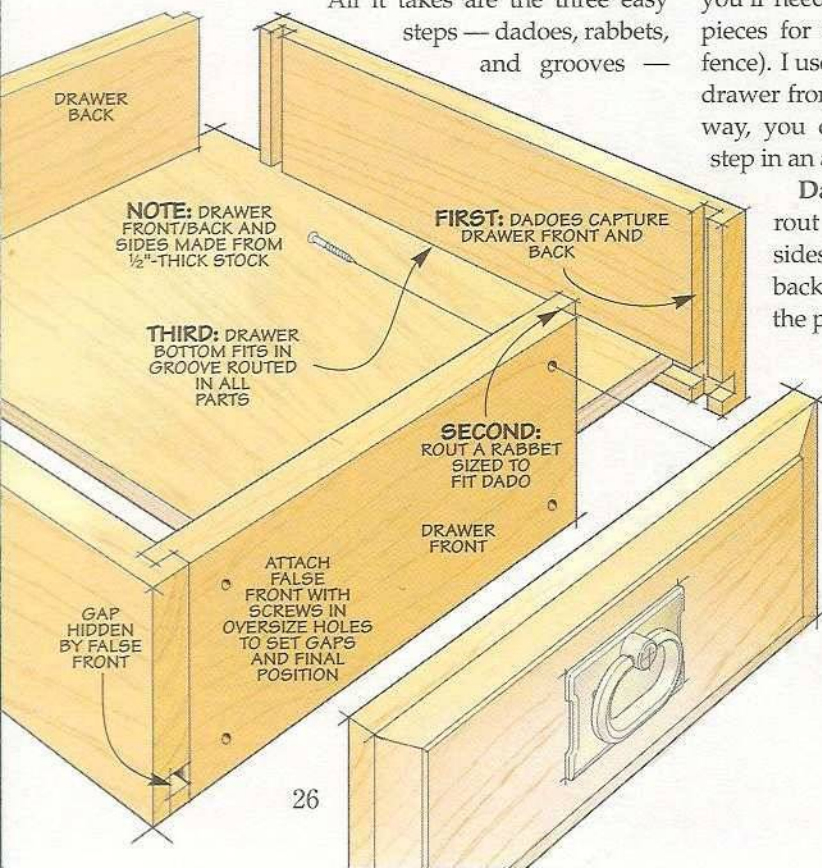



# 1 The Dado

The first step in making the joint is routing a dado across each end of the drawer sides. It will accept a tongue that will be routed on the ends of the drawer front and back.

In setting up for an accurate cut, I try to do as little measuring as possible. Instead, I use the workpieces themselves as setup gauges. You can see what I'm talking about in the left drawing. Here, I use one of the front or back pieces to position the router fence. The outside face of the front should align with the outside cutting edge of the bit. The only measuring I do is to set the bit height (right drawing).

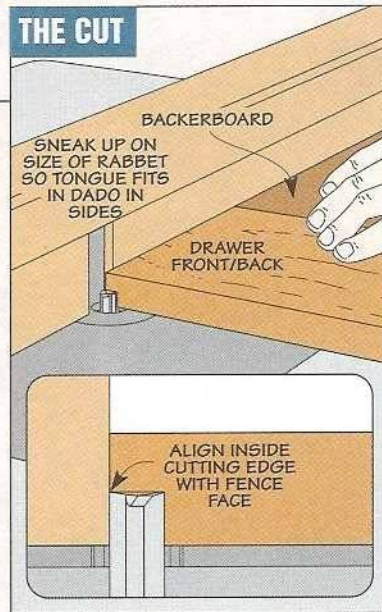
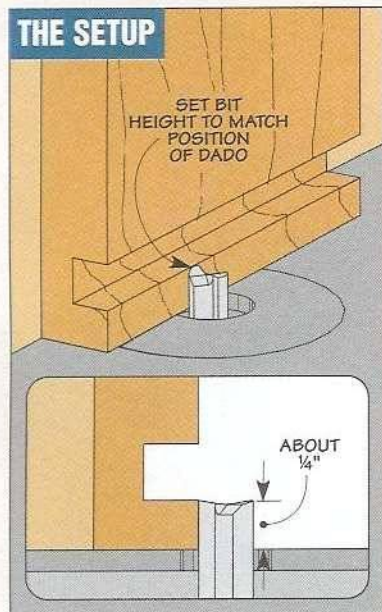
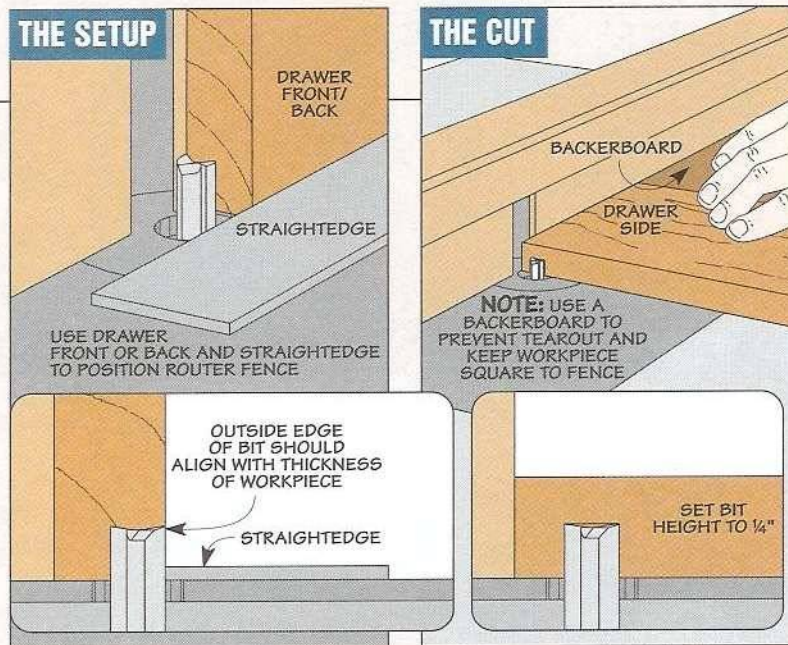

# 2 The Rabbet

The mating half of the joint is a tongue that's made by cutting a rabbet on each end of the drawer front and back. The goal of this step is to end up with a tongue that fits snugly in the dado in the side.

Like routing the dado, I use the workpieces to set up for the cut. In the "setup" drawing at left, you can see how I use the dado in the side pieces to set the bit height.

As for setting the fence, all you need to do here is position it so the face is flush with the *inside* cutting edge of the router bit. As always, make a test cut to check the setting.

# 3 The Groove

That takes care of the joinery, but there's still one step left. And that's a groove in the drawer front, back, and sides to hold the drawer bottom. I like to cut this groove about 1/4" up from the bottom edge.

If you plan on using 1/4" plywood for the drawer bottom, the fit may be a little loose. For a snug fit, you can do this on the table saw and make a couple passes with a standard blade to sneak up on the fit. 

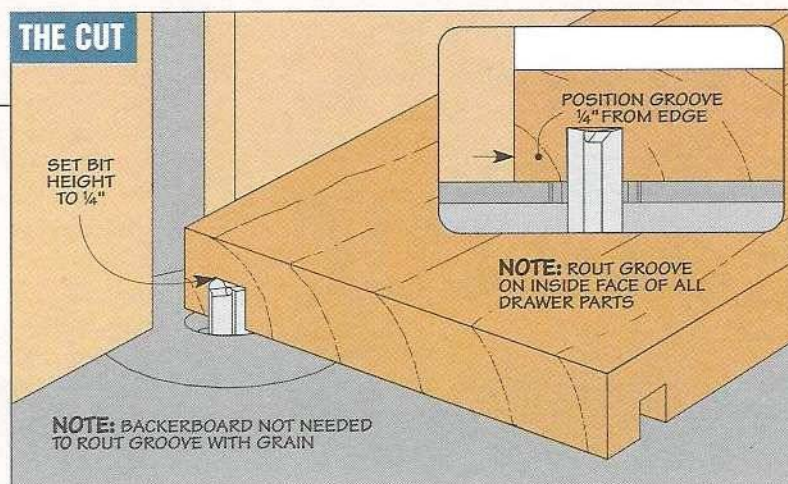







# building the Case

The organizer starts out by building a large plywood box (Figure 1). The first step is to cut the top, bottom, and sides. Then, you're ready for the tongue and groove joinery, which can all be cut on your table saw.

**The Joinery.** When I cut this type of joinery, I like to start with the grooves and dados. Then I can sneak up on the thickness of the tongues until they fit snugly.

The front and back will fit flush with the *outside* edges of the other parts on all four sides. So, you'll want to make sure the *inside* edges of the dados and grooves line up with the thickness of the front and back (Figures 1a and 1b).

And be aware that there are no dados in the top and bottom. These parts only get grooves along their outside edges.

Once you have the grooves and dados cut, you can start working on the tongues and then get ready to put the box together.

**Assembly.** It's a good idea at this point to dry-assemble the

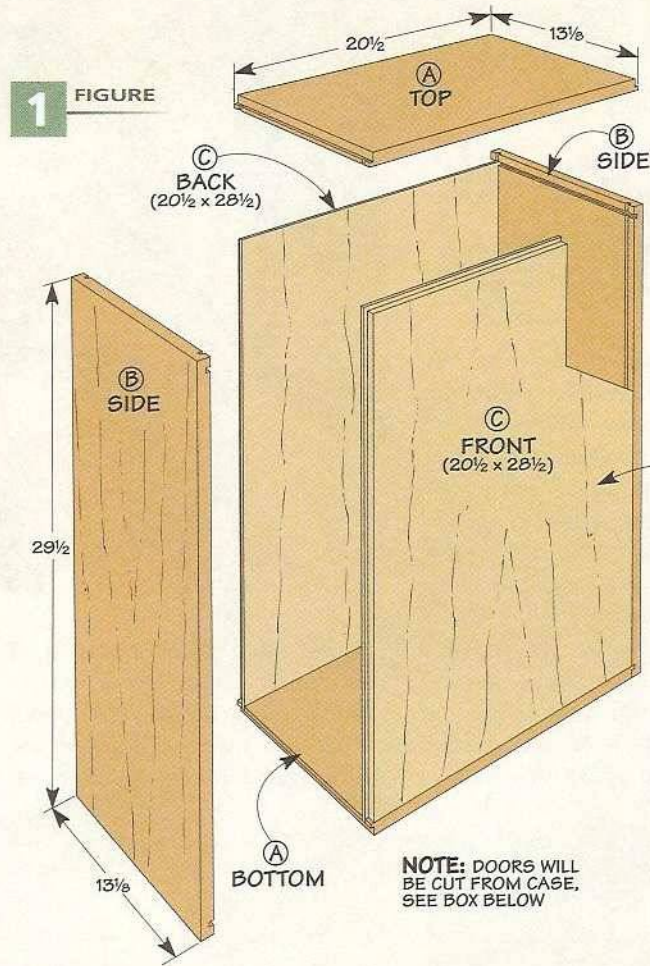

parts first to figure out the best way to put the case together. Once the parts were glued up, I clamped it all together and made sure the case was square.

And, finally, when the glue is dry, you're ready to turn the case into a hardware organizer with doors. The box below walks you through the process.

## Creating the Doors

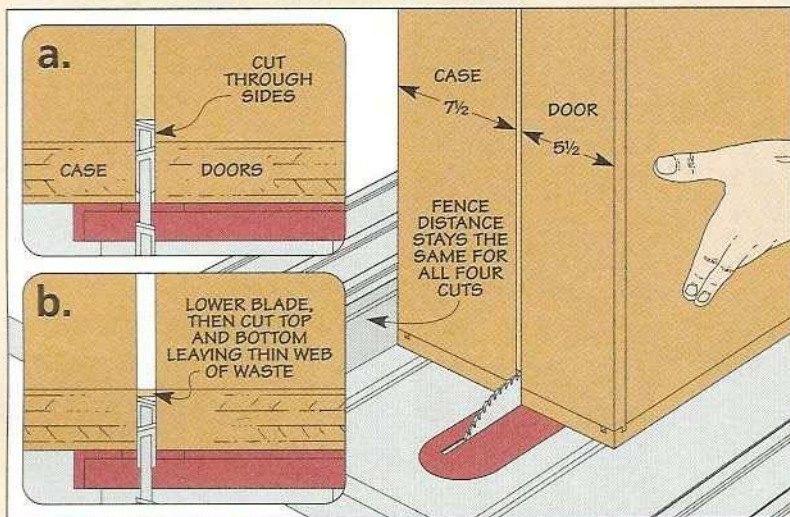

▲ **Split the Case.** First, cut through the case along each side (detail 'a'). Then, lower the blade and cut the top and bottom, leaving a little waste to prevent the saw kerfs from closing up and pinching the blade (detail 'b'). Cut through the remaining waste with a utility knife.

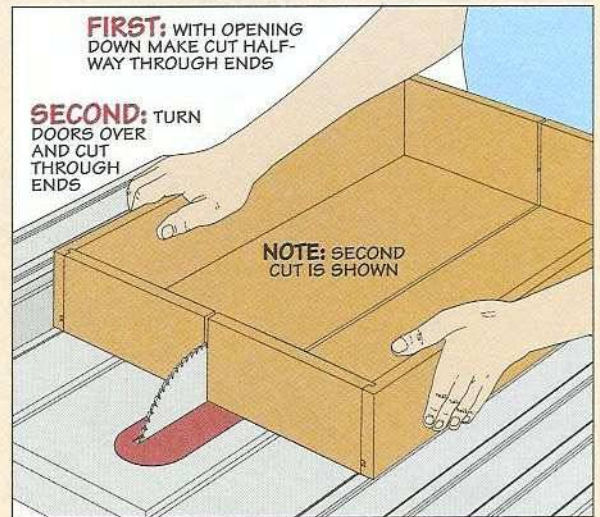

▲ **Making the Doors.** After adjusting the rip fence to cut two equal doors, lay the door opening down on your table saw. Raise the blade to cut halfway through the ends. Then, flip it over and cut down the middle.



# attaching the Doors & Hangers

Now that you've cut the doors off, you're ready to reattach them with hinges to make the cabinet.

A nice feature about this organizer is that the doors swing fully open, allowing easy access to everything that's stored inside. Piano hinges are great for this type of door, because the hardware may get heavy and cause the doors to sag. These hinges extend the full length of the organizer, giving you more surface to screw them to and adding extra support.



**Flush Fit.** For the doors to fit flush when closed, you'll need to shave the same amount of material off both the case and doors where the hinges will be installed, as

shown in Figure 2b. I did this by making a very thin cut on my table saw, raising the blade to match the thickness of the sides.

**Magnetic Catches.** Before you attach the hinges, it's a good time to install the magnetic catches, as detailed in Figure 2. Not only are there magnets to keep the doors closed (Figure 2a), but I installed one on each side of the case to help hold the doors open (Figure 2). These magnets mate with washers and flathead screws installed in the doors, as in Figures 2a and 2c. (For sources, turn to page 51).

The diameter of the catches is close to the thickness of the plywood, which can make drilling the holes for them a little tricky. To see how I did this, see Shop Shortcuts on page 16.

**Hinge Installation.** Now you can install the hinges. I used carpet tape to hold them in place while I drilled the pilot holes (see box on opposite page). When all the holes are drilled, attach the hinges to the case and doors.

After adding the door pulls, you're ready to mount the organizer

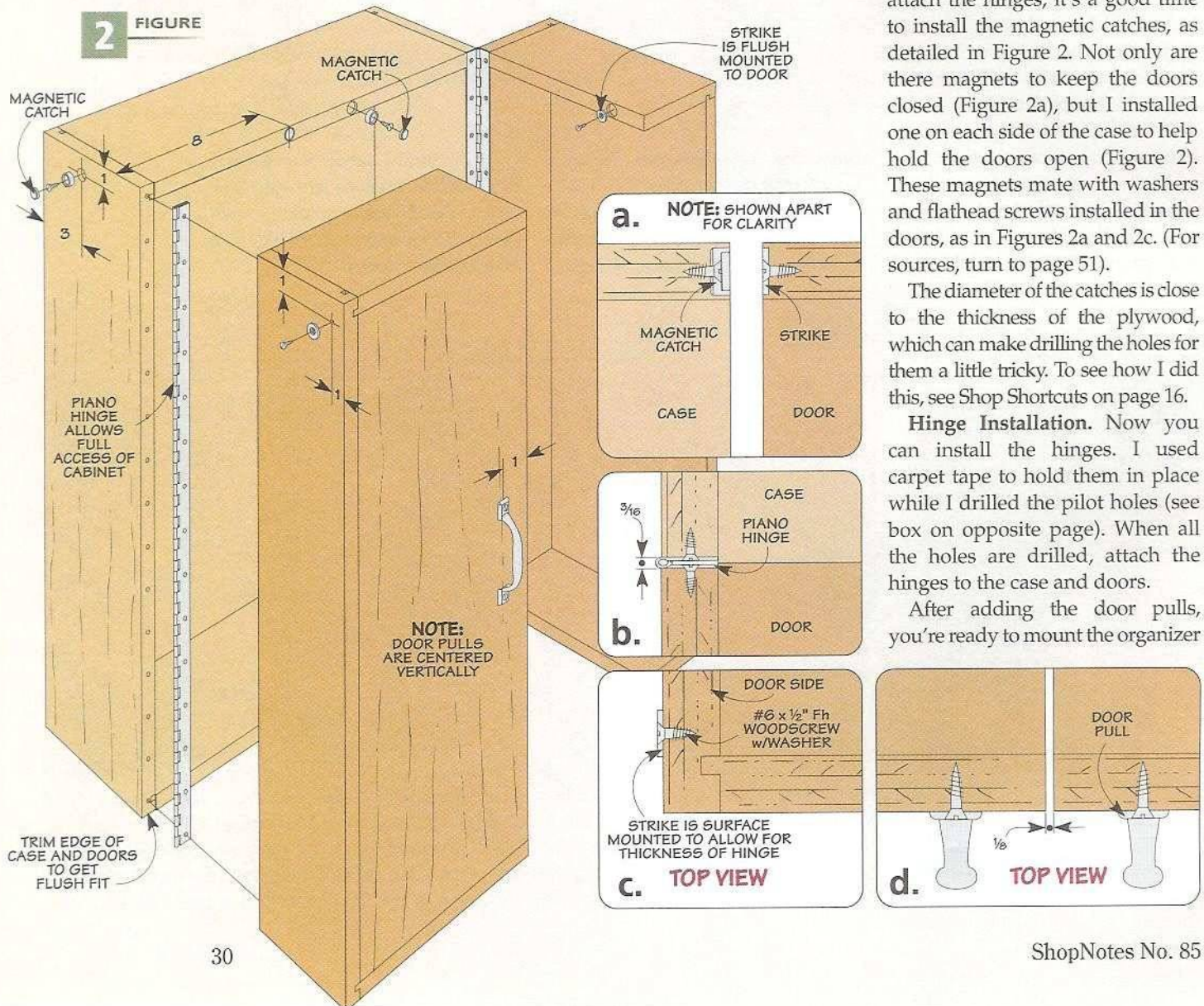



to the wall. Because the cabinet and hardware can weight quite a bit, I made sure to screw securely into the studs in at least four places.

**Bin Hangers.** Now, you can turn your attention to the bin hangers. While this organizer is a great way to keep all your hardware together, there may be times when you'll want to take hardware to where you're working. So, to make it easy to remove the bins, they simply hang on cleats.

**Aluminum Strips.** I was a little worried that hanging the bins on rabbeted strips of wood wouldn't provide enough strength to hold bins full of hardware. To give the cleats strength and durability, I added  $\frac{1}{16}$ "-thick aluminum strips. Also, the plastic bins slip easily over the aluminum strips (see photo at the top of the opposite page).

Before making the hangers, it's a good idea to have the bins in hand. The ones I used are *Akro-Mils* plastic bins (for sources, turn to page 51), but other bins may use a different method for hanging. By having the bins on hand before you start, you can make any required adjustments to the cleats.

Fitting the aluminum strips to the hardwood cleats is just a matter of rabbeting the top edge so they fit flush, as you can see in Figure 3a.

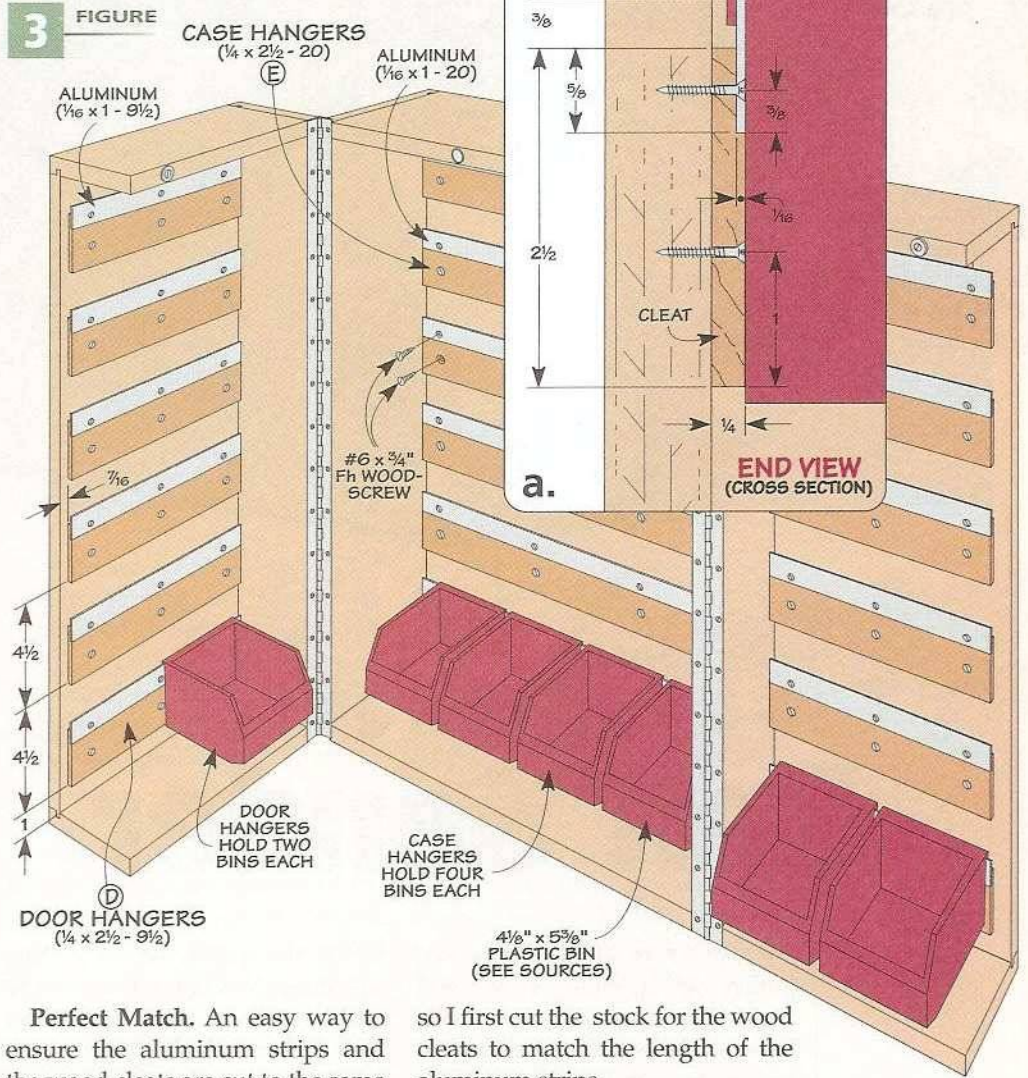

**Perfect Match.** An easy way to ensure the aluminum strips and the wood cleats are cut to the same length is to cut them together. The aluminum strips came in 4' lengths,

so I first cut the stock for the wood cleats to match the length of the aluminum strips.

Next, I cut a rabbet the entire length of the stock and then used carpet tape to hold the aluminum in place. That way, as I cut the hangers to length, the aluminum strip and wood cleat would match exactly. A carbide-tipped saw blade allows you to cut the hangers to size and leave a clean edge on the aluminum and cleat wood.

**Countersinks.** After cutting the hangers to size, I drilled countersunk mounting holes.

Finally, you can install the hangers, as illustrated in Figure 3. Just be sure to leave enough clearance between the hangers so you can easily lift the bins out of the case if you need to.

Now, you can start filling those plastic bins with all the little hardware items that are normally scattered about your shop. 

## Hinge Installation

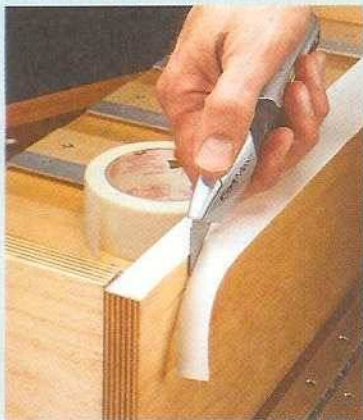

▲ **First, Tape.** Carpet tape will hold the hinges in place while you drill the pilot holes. Trim away any excess tape with a utility knife.

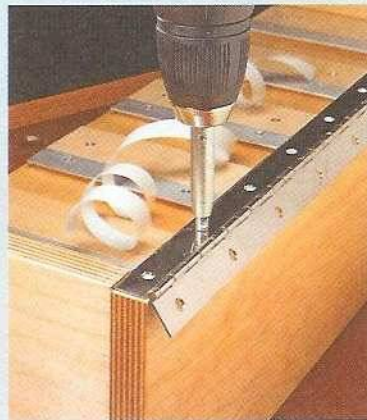

▲ **Second, Pilot Holes.** Once the hinges are stuck in place, drill pilot holes so the screws won't split the plywood.



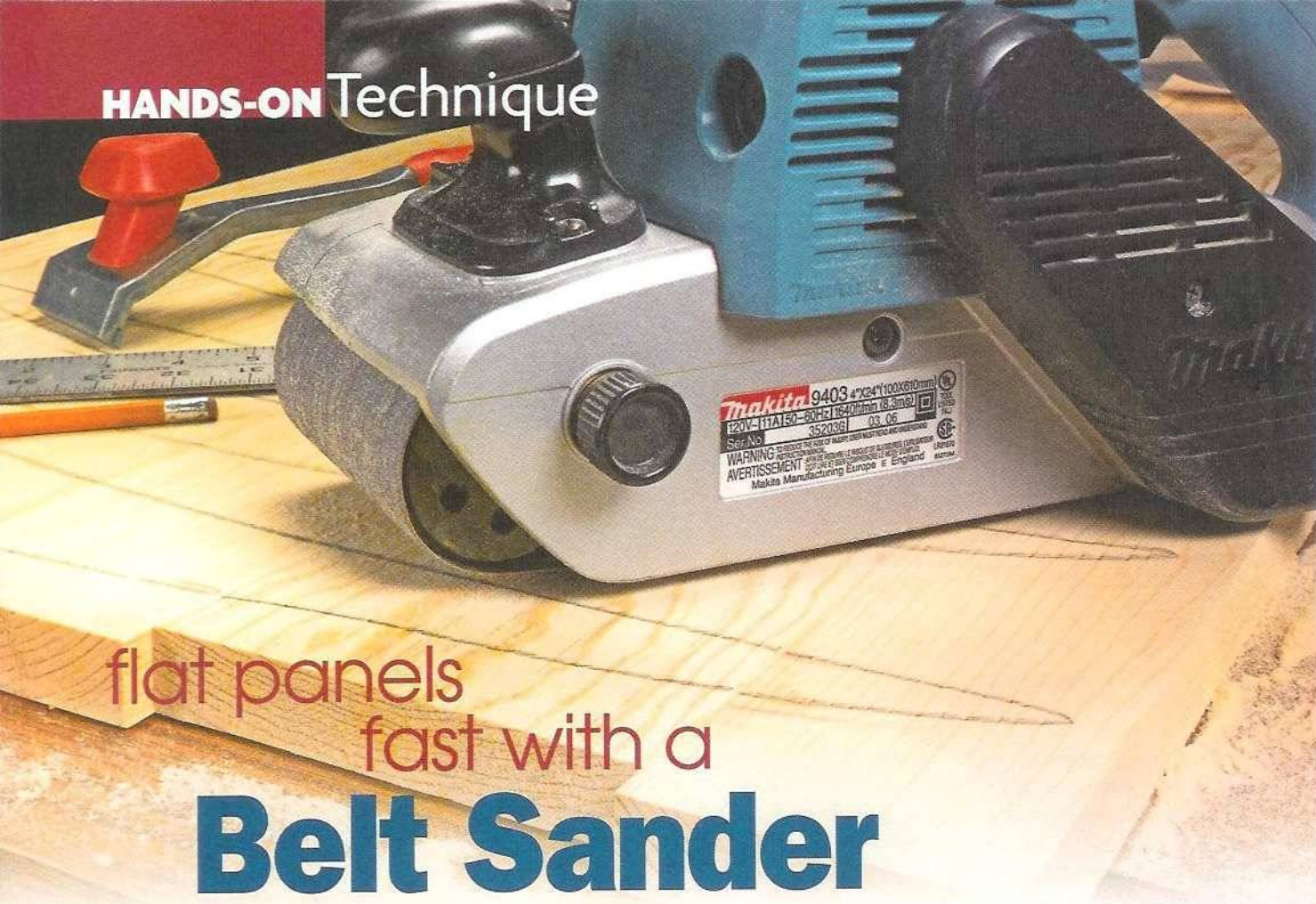

## flat panels fast with a **Belt Sander**

■ No matter how careful I am when gluing up a large, solid-wood panel for a project, the joints between the boards never seem to end up perfectly flush. So when the clamps come off, the panel needs to be smoothed out before moving on to the next step. To do this, I use my belt sander and a simple technique that gives me a perfectly flat panel.

**First Things.** There are a couple of things you'll want to think about before you get out the belt sander. First, whenever possible, I start by gluing up a panel that's oversized in width and length. A few inches of extra length and an inch in width means you won't have to worry quite as much about keeping the hard-to-sand edges perfectly square (see the box on opposite page).

Next, dried glue can quickly "gum up" a fresh sanding belt and really slow down your progress. So before I start sanding, I

check the panel for any glue squeeze-out. A few minutes work with a scraper saves time and effort later *and* increase the life of your sanding belts (lower left photo).

**Squiggly Lines.** There's one last help I like to give myself before starting to sand. You'll find that once you get started, it can be difficult to tell the high spots from the low spots and where you've sanded from where you haven't. The trick here is to give yourself a visual reference by dragging the side of a pencil back and forth

across the panel, as shown in the right photo below. Then, as you sand, the disappearing pencil lines will be a guide to your progress.

**Start Crossgrain.** Now, with the panel held tightly by the bench dogs and a clean, 80-grit belt on the sander, I start sanding straight across the width (crossgrain) of the panel. I know sanding across the grain sounds a little odd, but at this stage you're simply trying to level the joints and flatten the panel. And sanding crossgrain is the quickest way to get the job done.

▼ **Scrape First.**  
Before picking up the belt sander, scrape off any glue squeeze-out.



### **Reference Lines.**

*Squiggly pencil lines allow you to easily see your progress as you sand.*

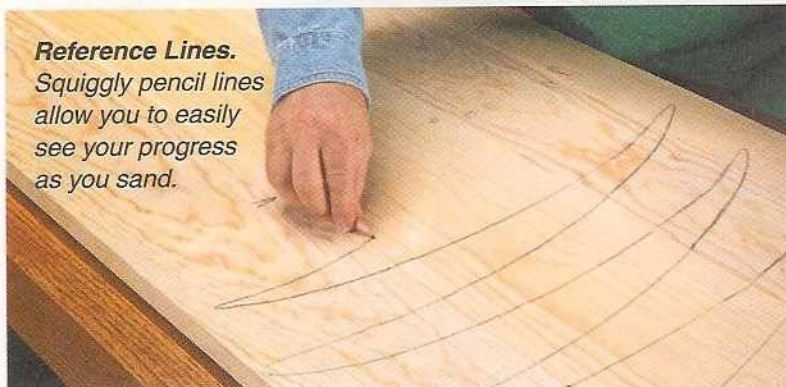





**Across the Grain.** Leveling the joints is a quick job sanding crossgrain with an 80-grit belt.

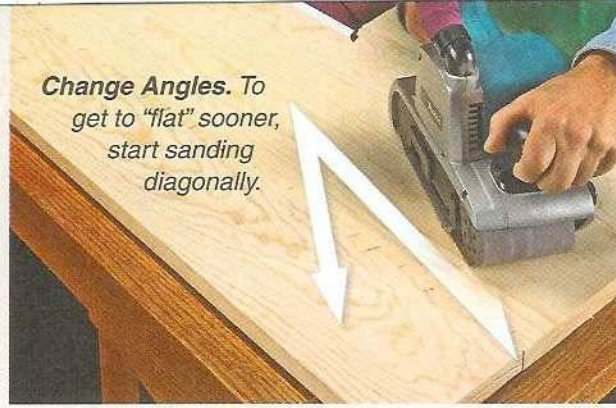

**Change Angles.** To get to "flat" sooner, start sanding diagonally.

Starting at one end, overlap your strokes as you work down the length of the panel (upper left photo). Concentrate on keeping the sander moving steadily to avoid creating dips or gouges.

I always take extra care and use a light touch near the edges. Try not to run more than half the sander off the edge before drawing it back. This, and steady control, helps avoid rounding the edges.

The belt sander will "cut" aggressively and that's exactly what you want. You'll be surprised how quickly the pencil marks vanish. Don't worry about the crossgrain scratches left by the

coarse sanding. They'll be removed quickly and easily later on.

**Change Angles.** Even though the idea is to get the job done fast, you want to avoid "getting in rut," so to speak. So after one perpendicular pass along the length of the panel, I repeat the process, now moving the sander diagonally across the panel (upper right photo). Just be sure to cover the entire surface, including the edges. If you find it hard to reach across the panel, turn it end for end.

**High Spots.** When all (or most) of the pencil lines are sanded away, lay a straightedge across the panel to check for flatness. The high spots you find are marked again to show where you need to focus your efforts (lower left photo). You'll want to do this every 6 or 8 inches along the length of the panel. Then, after switching to a 100-grit belt, I go back to work, still sanding across the grain and concentrating on knocking down the high areas.

**With the Grain.** After a couple rounds with the straightedge and sander, the panel should be flat.

The final step is to remove all the crossgrain sanding scratches by sanding with the grain.

On longer panels, it's easier to work on one section at a time. So first, I divide the panel into manageable sections with sets of pencil lines (right photo).

The goal is to create a smooth, scratch-free surface ready for finish sanding. So here, I switch to a slightly finer (120-grit) sanding belt. The key is to sand the surface thoroughly and then check closely for any little telltale scratches left from the previous sanding step. Work on each section until it passes the test and then finish up by lightly sanding the area between the sections.

Finally, clean off the dust and give the panel a close inspection with your eyes and fingers. You'll likely be rewarded with a panel that looks flat, feels smooth, and is ready for finish sanding. 🐶

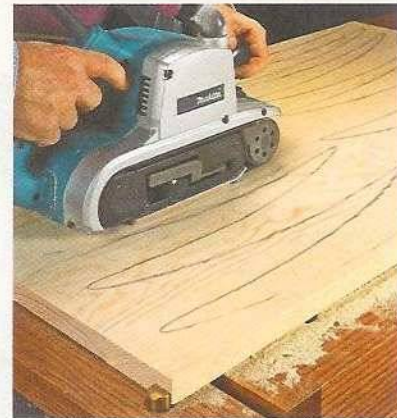

▲ **With the Grain.** Concentrate on one section at a time, and the crossgrain scratches will disappear quickly.



**Check for Flatness.** Lay a straightedge across the panel to find and mark the high spots.

## Smooth, Square Edges

When you don't have the luxury of much extra material to work with, keeping the edges square while sanding a panel flat can be a challenge. To do a thorough job, you want to run the sander over the edges. But without the full support of the panel, the sander becomes more difficult to control and keep flat against the surface. Rounded, uneven edges can be the result.

The photo at right shows an easy fix for this problem. You can use a scrap piece to create the "sacrificial" length or width the panel doesn't have. Here, the scrap piece is clamped in the dogs at the end of the panel. Now you have a little extra surface to work with and keeping the edges square won't be a problem.



## SHOP TIP

◀ **Better Control.** A scrap piece gives you more surface and better control for clean, square edges.





## table saw Miter Sled

Miter joints don't have to be a trial-and-error chore. With this miter sled, you can cut perfect joints every time.

■ I don't think there's a woodworker anywhere that hasn't been frustrated at one time or another when it comes to cutting miters on the table saw. It seems that no matter how hard I try, I'll sometimes end up with a gap in the joint when I get all the pieces assembled.

This table saw miter sled solves that problem. To make accurate cuts, the sled has two bars that ride in the miter slots on your table saw. This makes it solid

and slide smoothly for consistent cuts. And once you get the fences calibrated, you can cut dozens of perfect miters. The fences also have a T-track that allows you to use a stop block. This guarantees that your workpieces will be exactly the same length.

With all the miter sled's features, solid construction, light weight, and precision fences and stops, you'll be cutting perfect miter joints in no time.



# Exploded View Details

OVERALL DIMENSIONS:  
17"D x 30"W x 5"H

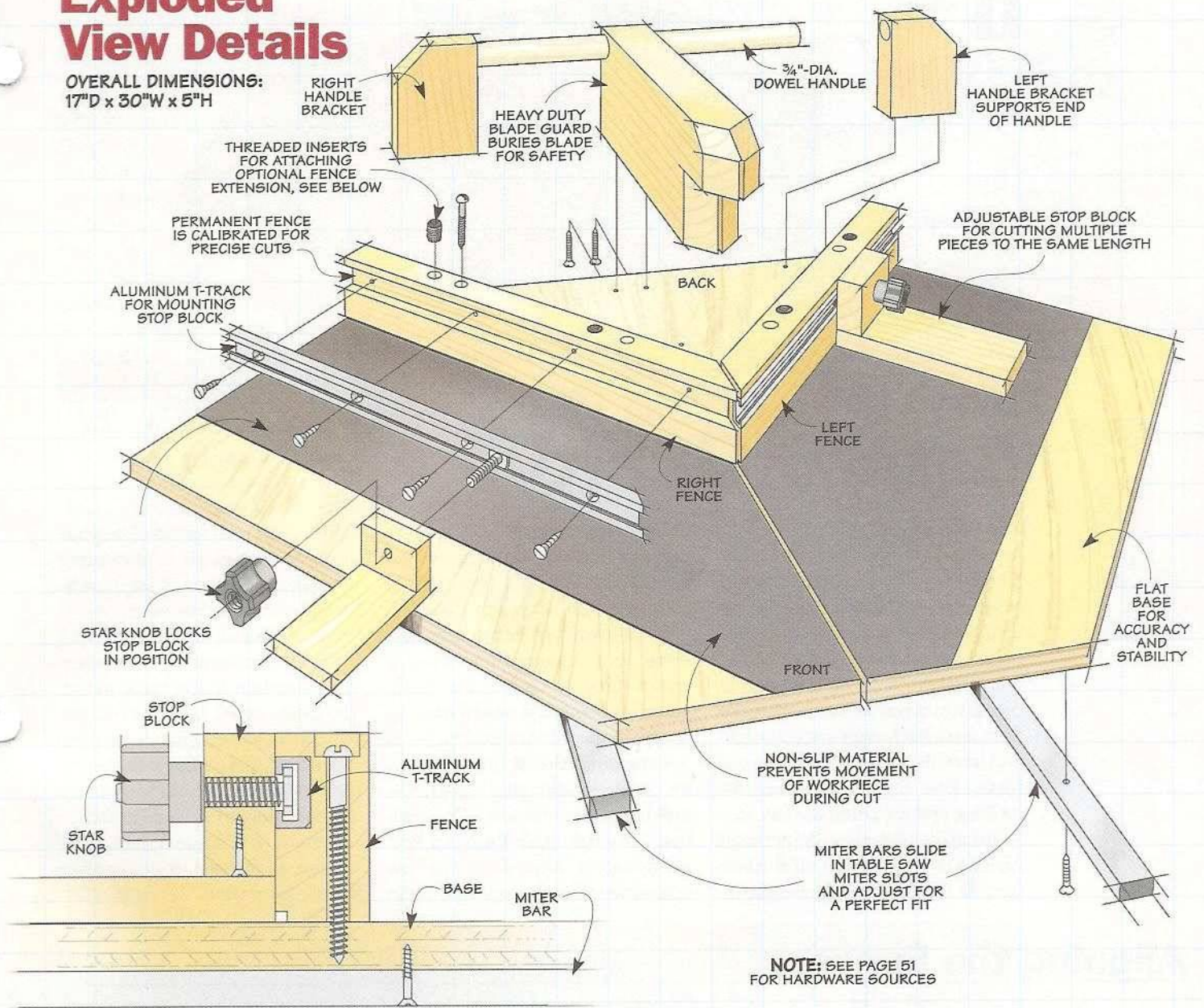

**OPTIONAL FENCE EXTENSIONS.** TO MAKE THE MITER SLED MORE VERSATILE, THESE FENCE EXTENSIONS ALLOW YOU TO USE THE STOP BLOCK WITH LONGER WORKPIECES

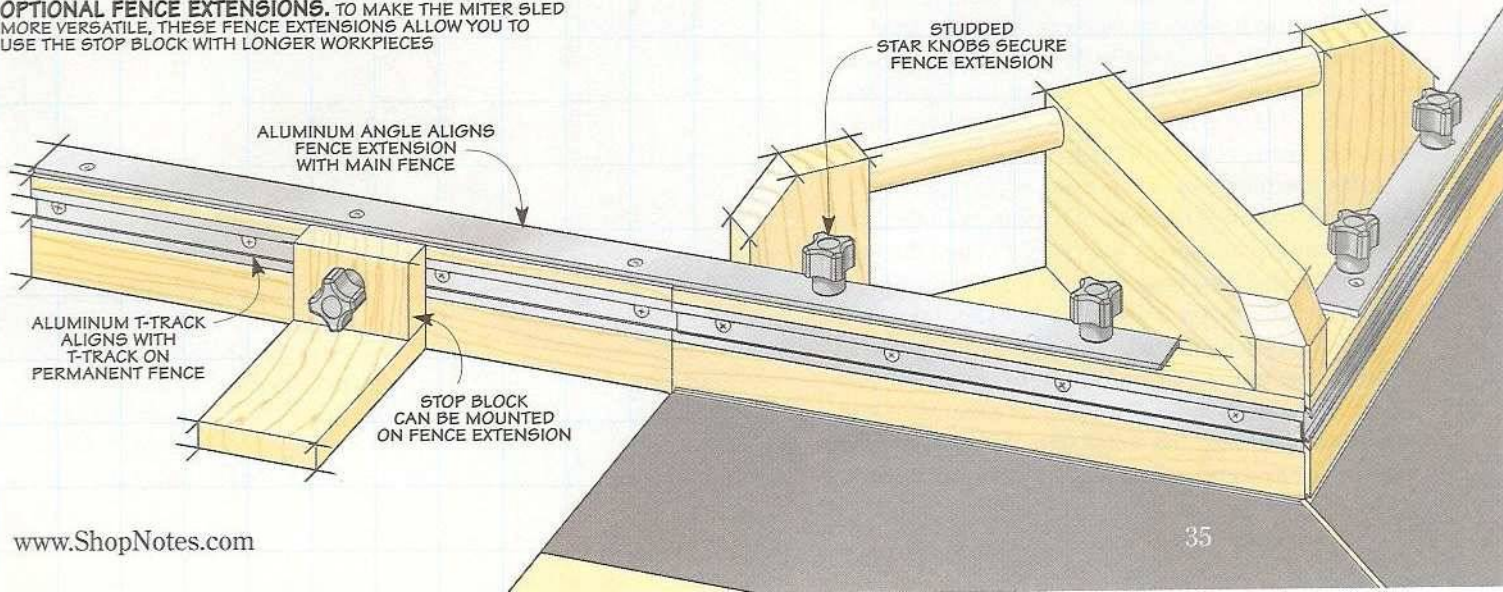



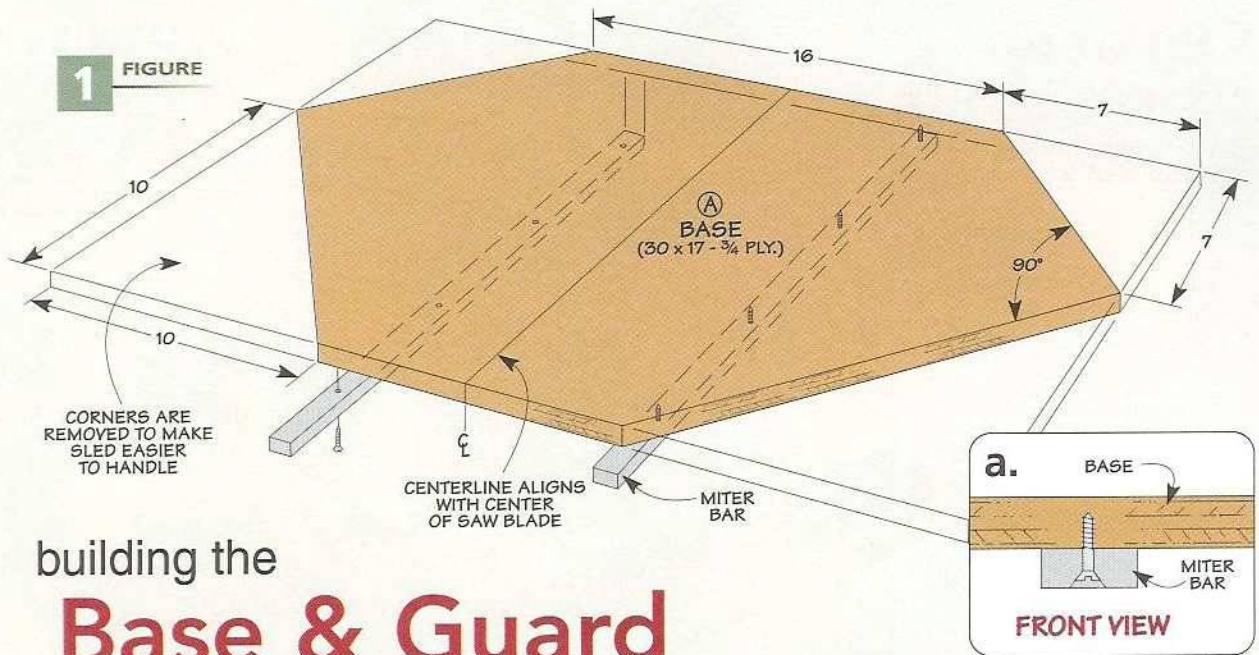

## building the Base & Guard

The base of the miter sled is the foundation for the whole assembly. So you'll want to use a material that's flat and stable. That makes installing and adjusting the other parts easier. I chose  $\frac{3}{4}$ " plywood.

I started with a rectangular piece. You'll want to make sure the front and back edges are straight and smooth. That way, you can use them later as a reference for locating and adjusting the fences.

To make the sled lighter and easier to manage, I cut off the corners of the base, as shown above.

Once that's done, you'll need to find and mark the centerline of the base. You'll use this line later to align the sled with the blade on your table saw. This centerline also serves as a reference line when it comes time to attach the blade guard and fences. (I used a framing square to mark the centerline.)

**Attaching the Runners.** Now for the challenging part — mounting the runners. The trick here is to first attach the miter bars using carpet tape. The tape just holds them in place so you can

attach them with screws. Use your table saw as a guide for mounting the miter bars. You can see how to do this in the box below.

**Blade Guard.** Once you've got the runners mounted, you can turn your attention to the blade guard. The blade guard does two things. First, it shields your hands from the saw blade. As you finish the cut on the workpiece, the blade ends up "buried" under the blade guard.

Second, the blade guard adds stability to the sled. It ties the two sides into one unit.

## Aligning the Runners

Since the miter sled uses two miter bars, it can be difficult getting them aligned to your table saw. Here's an easy trick for attaching them that will ensure smooth operation. You'll use carpet tape as a helping hand.

The first thing you need to do is insert two pennies in each miter slot of your saw. See the drawing at right. This will hold the miter bars proud of the table surface so that the carpet tape will "grab" the base.

After attaching two or three pieces of carpet tape to each miter bar, align the ends of the bars with the front of your saw table. Next, you'll want to align the back edge of the sled base flush with the front of the saw, as shown at right. But you'll want to be careful not to let it touch the carpet tape yet.

Now, carefully move the base so its center line is in line with the saw blade. Then it's just a matter of lowering the sled onto the miter bars. Finally, you can remove the sled and permanently attach the runners.

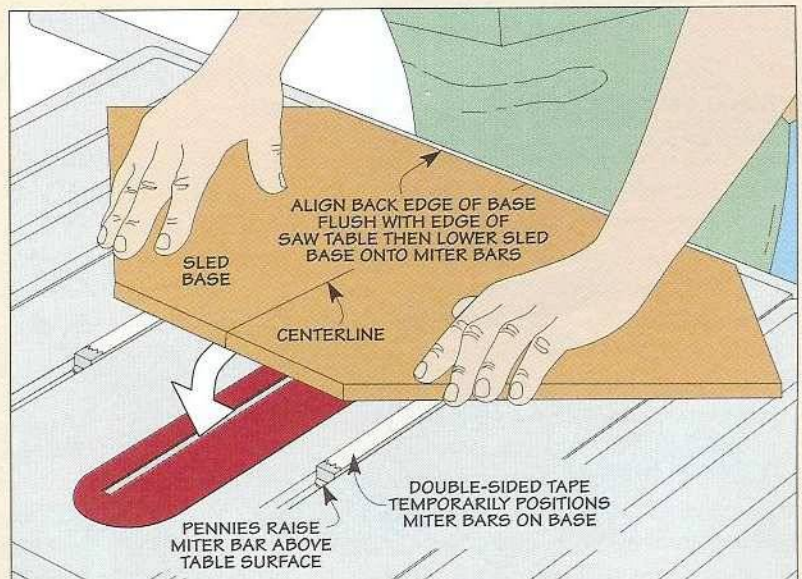



# Blade Guard Step-by-Step

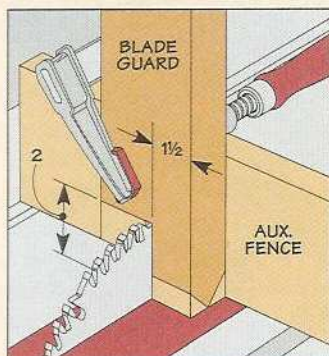

▲ **The First Cut.** Using an auxiliary fence on your miter gauge, start forming the notches for the permanent fences in the blade guard.

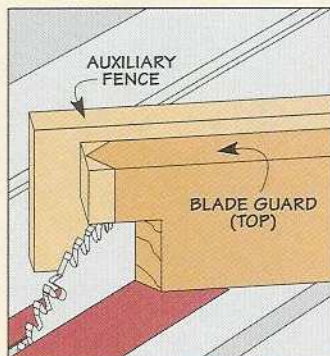

▲ **Miter for the Fences.** Rotate your miter gauge 45° to complete the notches where the fences will rest. Make two cuts to center the point.

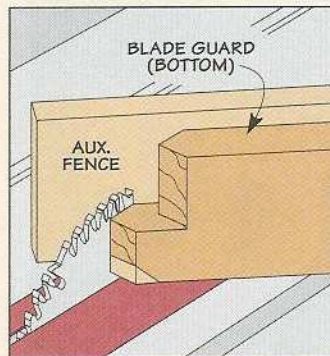

▲ **Forming the Nose.** Flip the guard over and make two 45° cuts. The point should be centered to help with aligning the guard with the blade.

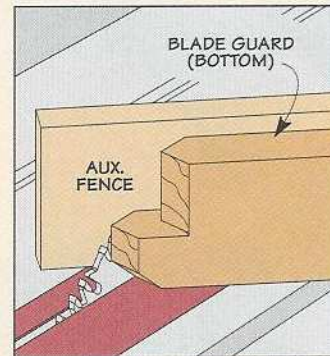

▲ **Compound Cut.** The last set of cuts is on the top of the blade guard. Tilt the saw blade 45° and cut the remaining bevels from the nose.

To make the guard, cut a block to width and length. Then following the steps above, make the cuts to form the “nose” of the guard.

Once the blade guard is cut to shape, you’ll need to drill a hole through it for the handle that will be added next. You’ll want to make sure the hole is square to the sides of the guard. That’ll make it easier to fit and align the handle later.

To attach the guard to the base, apply glue to the bottom edge and align the back of the guard flush with the back of the base. Be sure to center and square it to the reference line you made earlier. Then simply screw it in place from underneath. This is where you’ll want to watch where you place the screws to keep them out of the path of the blade.

**The Handle Assembly.** The handle is simply a  $\frac{3}{4}$ ” dowel that slips through the blade guard. It’s held in place by two end brackets. The handle gives you excellent control of the miter sled. It also gives you a good place to rest your hands to keep them out of the blade’s path during a cut.

You’ll cut the handle brackets to size then drill a stopped hole in each bracket. This is for attaching the dowel (see the front view on the right). The corner of each bracket is cut off. You can see details of this in Figure 2a on the right.

Now, you can put the handle assembly together. Slip the dowel through the blade guard, then attach a handle bracket at each end of the dowel. A drop or two of glue will keep the dowel from spinning when using the sled. Then you can glue and screw the brackets to the plywood base from underneath to tie everything together.

**Ready for Fences.** At this point, the base of the sled is complete except for the two permanent

fences and non-skid material. You’ll work on those next.

But before you move onto making the fences, take the time to check the fit of the sled on your saw and make any last-minute adjustments. You’re looking for a smooth fit in the miter slots.

**2** FIGURE

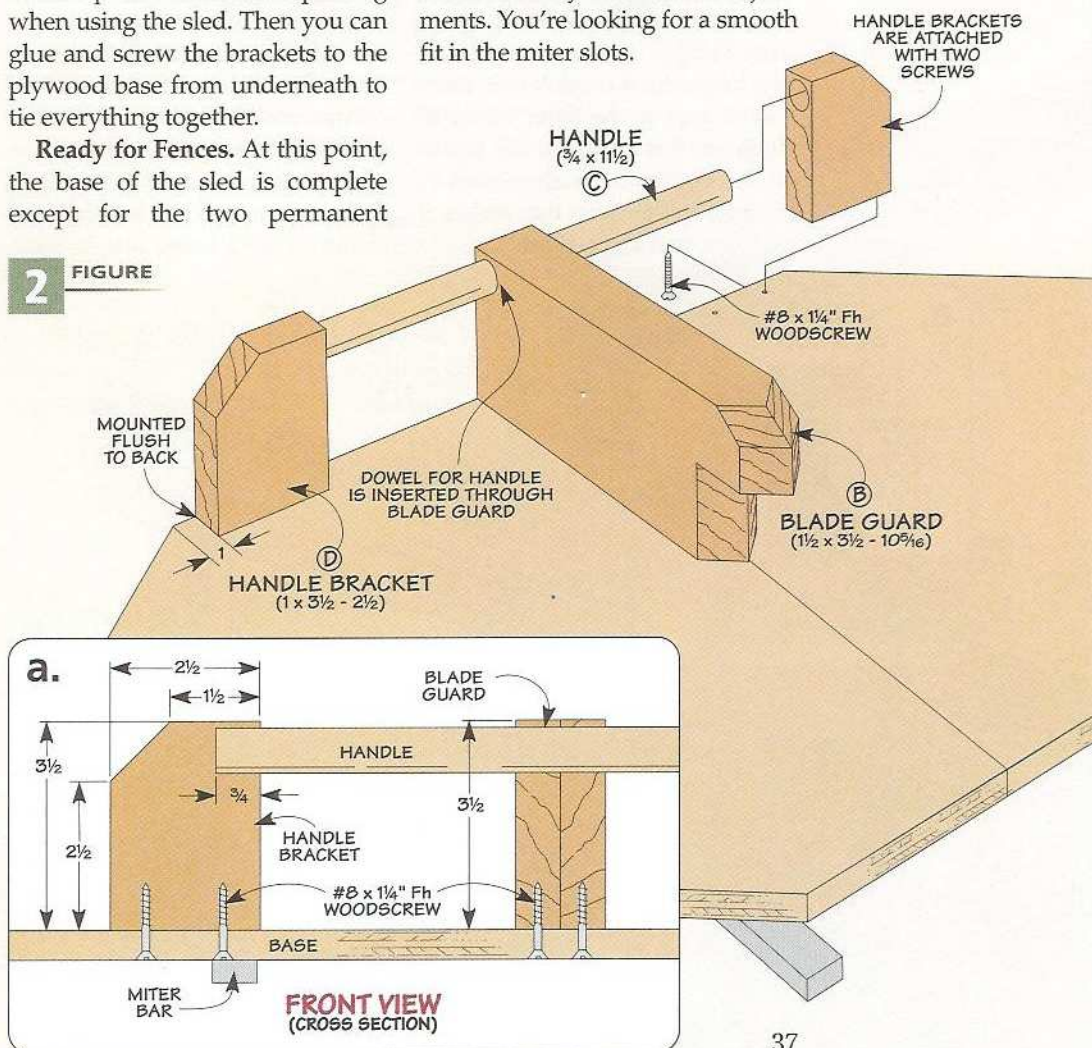







**Test Cuts.** Once the fence is fastened tight, make some test cuts on two straight boards and adjust the fence until you get a perfect fit. To see how to do this, turn to *Shop Short Cuts* on page 17. Then do the same for the other fence.

**Non-Slip Surface.** Sometimes when I'm cutting miters, the workpiece has a tendency to "creep" as the saw blade starts to cut. To solve this problem, I found some non-skid material that is used on stairs. As you can see in Figure 4, I aligned the material with the front face of the fence. You'll have some material hanging over the edge of the base to trim with a utility knife.

**Stop Blocks.** The last pieces you need to complete the miter sled are stop blocks. They're easy to make but they serve an important role.

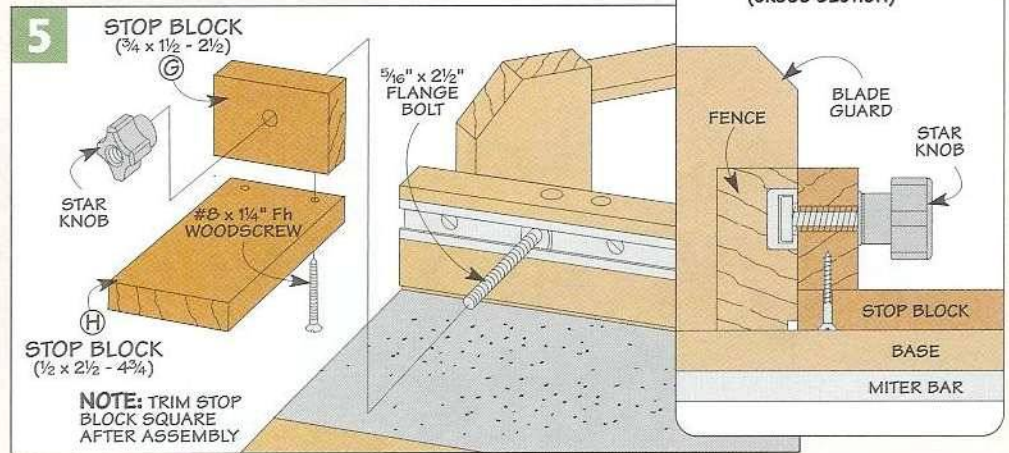

They help you cut your workpieces to a consistent length.

The stop blocks are just two pieces glued and screwed together at right angles (see Figure 5 above). You'll drill a hole in the back that's used to attach them to the fences.

You can make two of them so that you can have one on each fence.

**Perfect Miters.** With the fences and stop blocks in place, your miter sled is complete. Make some final test cuts and you're ready to cut perfect miter joints. 

## Optional Fence Extensions

The miter sled is great for cutting perfect miter joints. But I found I sometimes needed to make repetitive cuts on pieces that were longer than the fences. So I added these fence extensions.

The stock for the fence extension is identical to the stock used for the stationary fences, including the aluminum T-track. The only difference is that I added a length of aluminum angle for attaching the extension to the stationary fence (see drawing below).

Once the fence extensions were complete, the first thing I did was

cut a 24" length of aluminum angle. After aligning one end flush with the outside end of the fence extension, I fastened the aluminum angle in place, as shown in the drawing below.

I wanted to have an easy way to attach and remove the fence extension, so I used the threaded inserts and studded knobs shown below. I drilled the mounting holes in the aluminum angle and used the holes to mark the location for the threaded inserts. (For some tips on installing the threaded inserts, turn to page 50.)

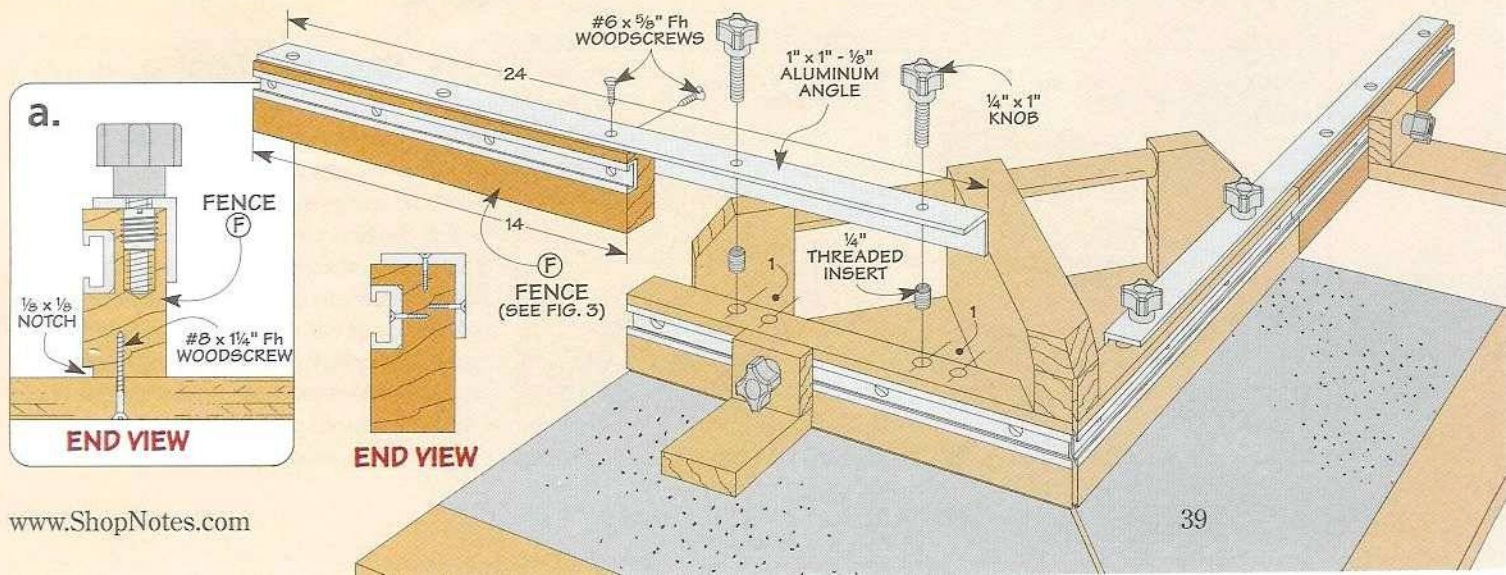



# 7 tips for clean Plywood Cuts



Plywood veneer splinters easily when cut. Use these simple tips to prevent it.

- 1
**Scoring.** ▶ The key to preventing splinters from appearing along the edge when you crosscut plywood is to pay special attention to the thin veneer layer. One of the easiest ways to do this is to score or cut through the wood fibers of the veneer before making the cut. A sharp knife or a rotary fabric cutter, like you see in the photo at right works great for this. You'll find this method is fast and effective. But you'll need to take some time to align the saw blade accurately with the score line. That way, you'll cut through the fibers you already scored.

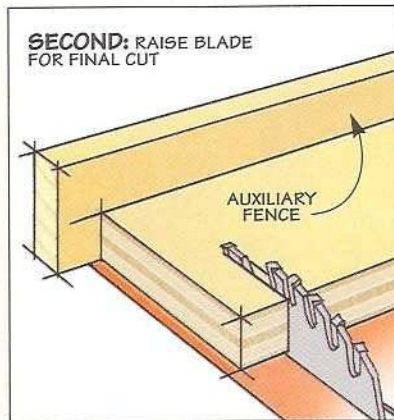
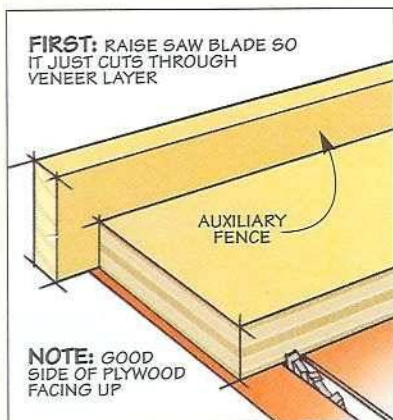
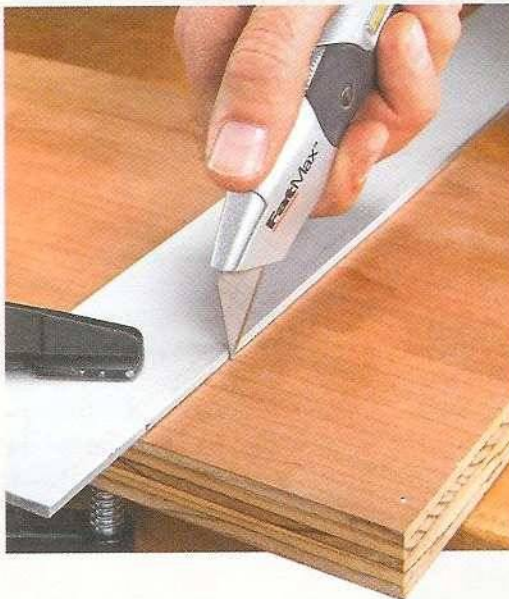

- 2
**Saw Blade Scoring.** ◀ Another method to prevent splintering is to use your saw blade to score the veneer of the plywood. With this method, you'll need to make two passes, as shown at left.

On the first pass, set the blade at a height that will just cut through the lower veneer layer. Next, you can raise the blade and complete the cut with a second pass. I like to use an auxiliary fence on my miter gauge to help keep the workpiece aligned with the blade. And if multiple pieces are being cut, I add a stop block to ensure the pieces are the same.



**3 Adjust Blade Height.** ▼ The height of the blade as it cuts through the plywood can be a cause of splintering. If the blade is set too high, the teeth cut almost perpendicular to the veneer. This makes a clean cut on top but it causes chipout at the bottom. You can quickly correct this problem by simply adjusting the blade height so that it's only  $\frac{1}{8}$ " above the plywood. The change in cutting angle reduces chipout.

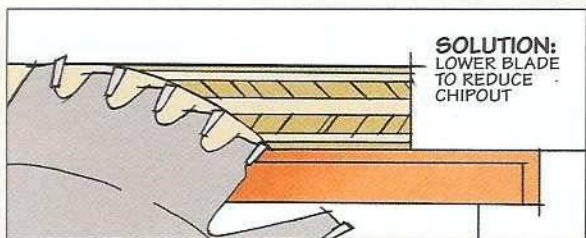
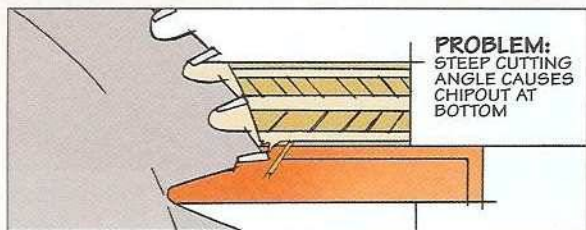

**5 Zero-Clearance Inserts.** ▼ A good way to get a clean cut is to have no opening between the blade and the table saw insert. Then as the blade cuts through the workpiece, the insert is there to back up the bottom veneer of the plywood. This ensures you'll make a clean cut each and every time.

A quick, zero-clearance insert can be made by using carpet tape to attach a piece of hardboard to your table saw. Then raise the blade through the top. You can learn more about other zero-clearance inserts on page 46.

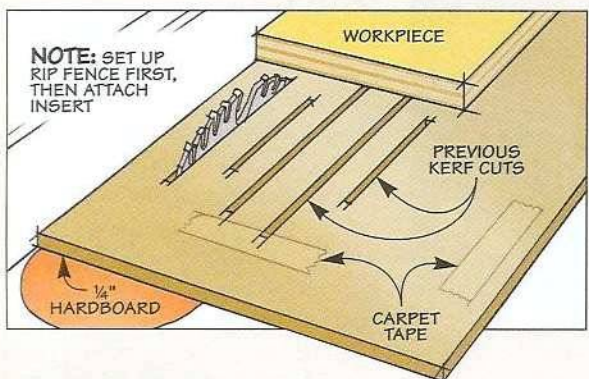

**7 Circular Saw.** ► Cutting plywood with your circular saw presents a different problem. Here, the splintering occurs on the top side. If I need a clean cut on both sides, I start by placing the good side down. Then, I make an auxiliary hardboard plate, like you see in the illustration at right, and attach it to the baseplate of the saw. The plate acts as a zero-clearance slot for the blade as it cuts the plywood.

**4 Tape.** ▼ Another way to prevent splintering is to support the veneer layer as the blade makes the cut. One of the easiest ways to do this is to apply a strip of masking tape directly over the layout line (see photo below). This gives the face veneer enough support to keep it from being torn away by the saw blade. After making the cut, slowly remove the tape by pulling it toward the edge of the cut.



**6 Backer Board.** ▼ A quick method of supporting the veneer layer is to place a piece of hardboard directly below the workpiece as you make your cut. The hardboard supports the bottom veneer layer so it can be cut cleanly without splintering. Again, I like to add an auxiliary fence to the miter gauge, like you see in the illustration below. This helps keep the workpiece aligned with the blade and holds the backer board firmly in position as the cut is made.

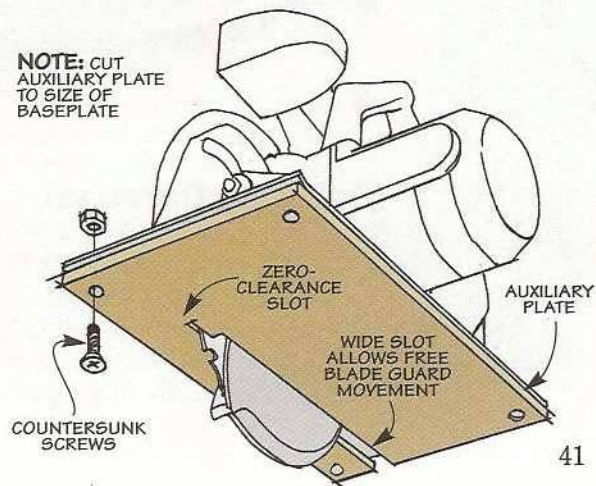
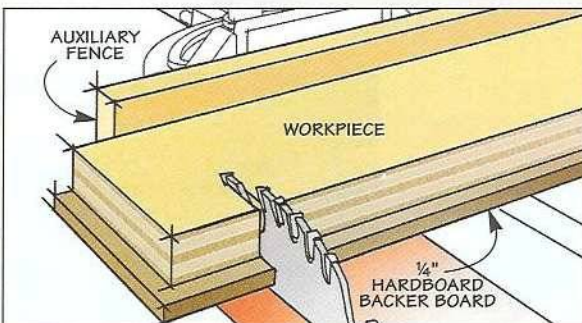



# versatile Pegboard

Here are seven handy ways to make use of pegboard in your shop.

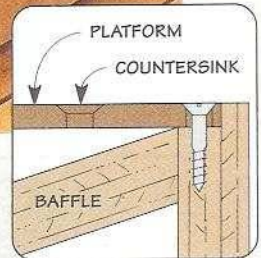
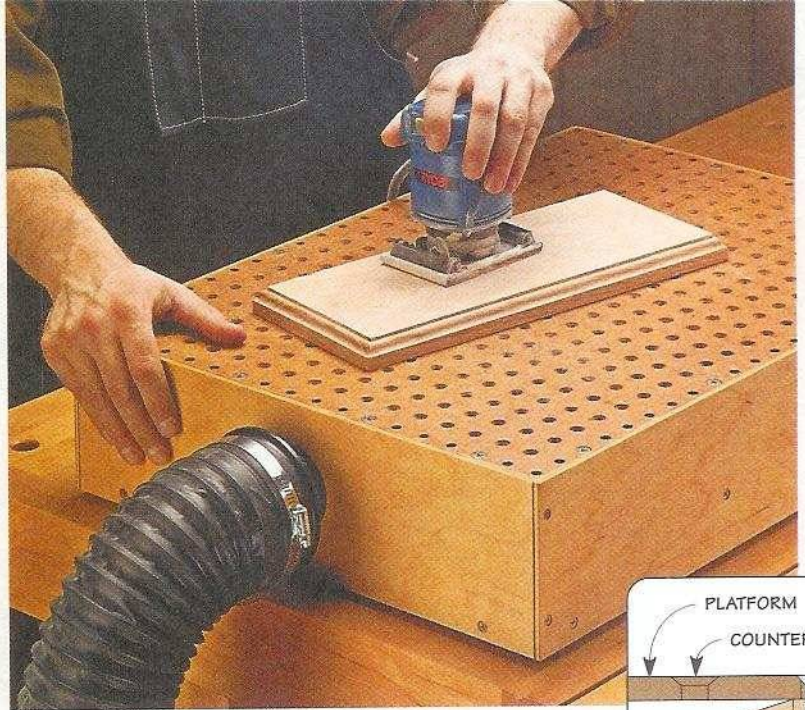

## ■ Sanding Table

A pegboard surface provides a convenient way to pull dust down into the dust collector of this sanding table (photo and drawing at right).

The table is a simple box that houses a baffle to channel the flow of air inside the table. A hole is cut into one side of the box to hook up a shop vacuum or dust collector.

The pegboard top is what really makes this table work. It acts as a sanding platform and helps funnel dust down into the box.

To improve the airflow into the box, I drilled a shallow countersink into the existing holes.

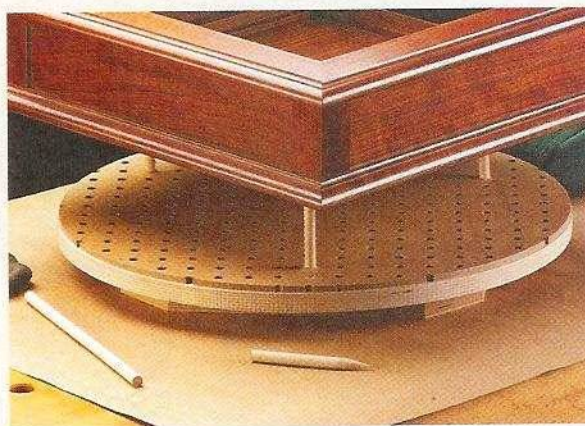
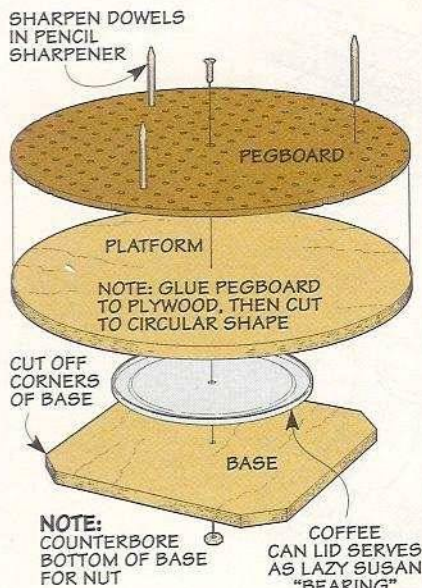
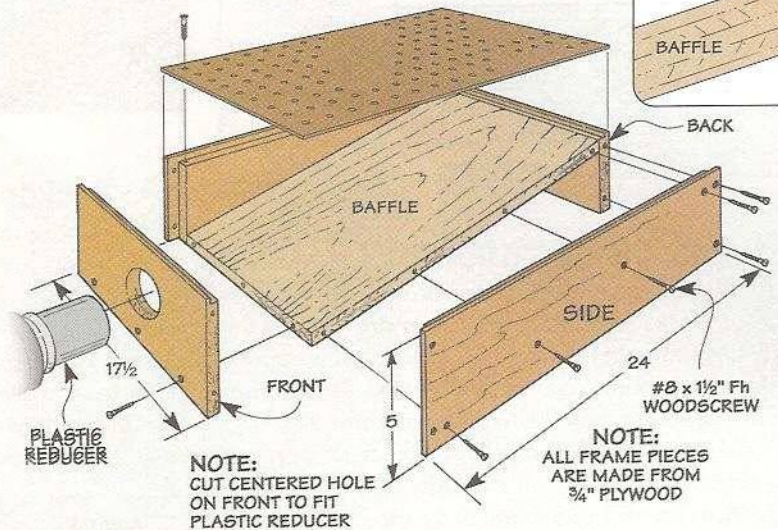

## Finishing Carousel

The carousel above allows me to rotate a small project to easily reach each side while I'm applying a finish. Pointed pegs lift the workpiece, so I can get to the bottom. A piece of pegboard on top of the plywood platform serves as a template when drilling holes for the pegs. Plus it adds extra support to the pegs.

## Drill Guide

Attach a cleat to one side of a small piece of pegboard and you have an instant drilling guide for shelf pins. Drill the first hole and insert a dowel into it to hold the jig while you drill the rest of the holes.

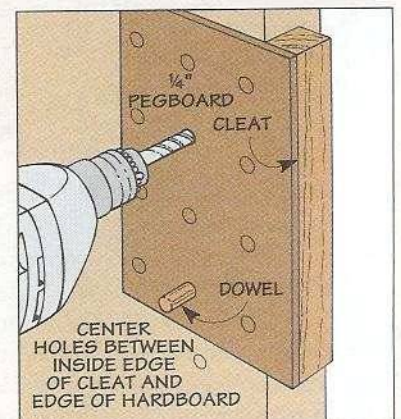



## Tool Caddy

If you need a way to keep small hand tools organized, then build the lazy Susan tool caddy shown in the photo on the right.

The caddy has pegboard sides held by grooved corner posts. You'll want to make sure the holes in the opposite sides line up with each other. You can slide  $\frac{1}{4}$ " dowels through the sides to divide the space inside the caddy (drawing at right). By making the dowels extra long, you'll have a great place to hang small hand tools.

A  $\frac{3}{4}$ "-thick bottom screwed to the caddy keeps it square. Self-adhesive magnetic strips can be added to the outside of the caddy to hold smaller tools, like driver bits or a short metal rule.

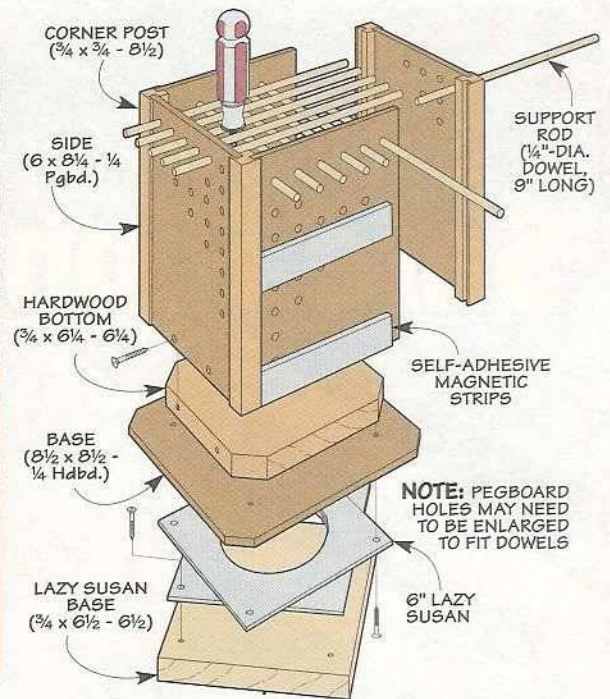
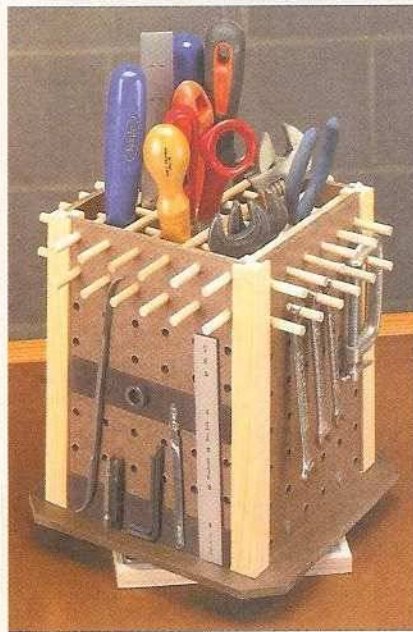

## Vertical Tool Hangers

With just a little ingenuity, you can add storage in unlikely places, like you see in the drawing and photo at right.

A good way to add storage to your contractor's saw is to sandwich a piece of pegboard between the extension wings and the top of the table saw. The pegboard hangs below the table and provides a way to store wrenches, blades, and other saw accessories.

To add storage to your workbench, you can nail some cleats to the legs and upper and lower end rails of the bench (far right photo). Then place the pegboard against the cleats and tack a second set of cleats down to hold the pegboard in place.

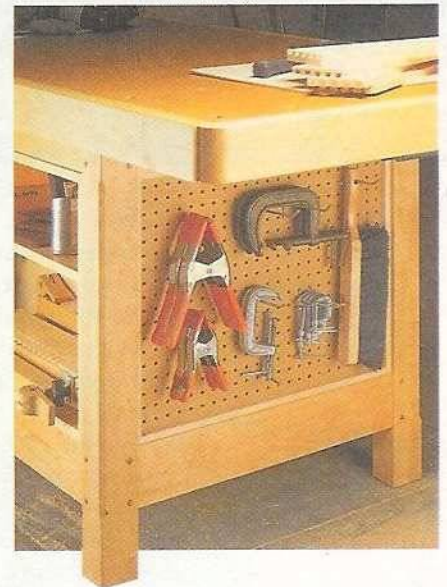
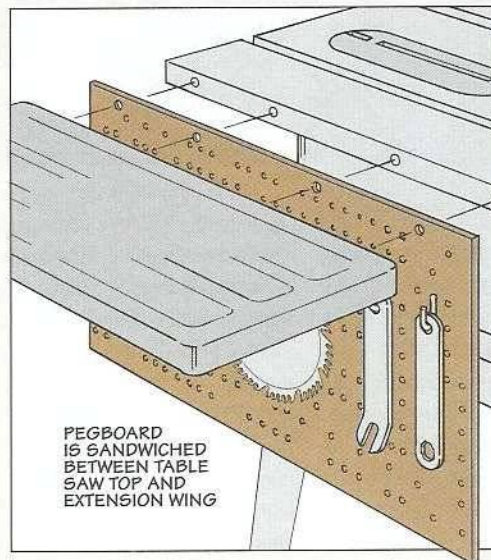

## Pegboard Add-on Simple Shelf

This shelf is a great way to store small items on pegboard. And the shelf can simply hang on L-hooks inserted into the pegboard (see inset photo at right).

For added support, I attached a back piece to the bottom edge of the shelf (main photo). The back also provides an area to screw in several more L-hooks. These hooks create a convenient place to hang a few extra hand tools.



▲ To add storage to pegboard, use L-hooks to attach a small shelf.





## Setting up for **Safe Ripping**

All you need for safer rip cuts on the table saw are a few simple helpers.

■ Ripping stock on the table saw may seem like a pretty straightforward job. So it might be easy to forget about a serious hazard that you really want to avoid — kickback. But the good news is that it's really easy to avoid this problem. All it takes to make rip cuts a lot safer and even more accurate is to get into the routine of always using a few, simple helpers. These easy-to-use accessories put *you* in better control and rip cuts will be much safer.

**Blade and Fence.** Before talking about the accessories I use for rip cuts, I should mention a couple of things. First, you'll get less cutting resistance and safer, cleaner cuts with a sharp blade on the saw. And next, before making a rip cut, I like to double-check the alignment of the rip fence. You'll avoid the chance of binding if the fence is perfectly parallel to the blade.

### ADD A SPLITTER

Installing a splitter on your table saw is probably the number one way to avoid the problem of kickback while ripping. And a shop-made splitter, like the one shown in the drawing at left, can make this a real low-cost but high-value safety addition.

**The Benefit.** As you can see in the photo above, the thin, hard-

wood splitter is installed in a shop-made zero-clearance insert. It's positioned behind and directly in line with the saw blade. As the board passes through the blade, the saw kerf slides onto the pointed splitter. What this does is eliminate the possibility of the kerf closing and pinching the back of the saw blade, with kickback being the possible result. And as a bonus, the action of the splitter will minimize burning and rough cuts.

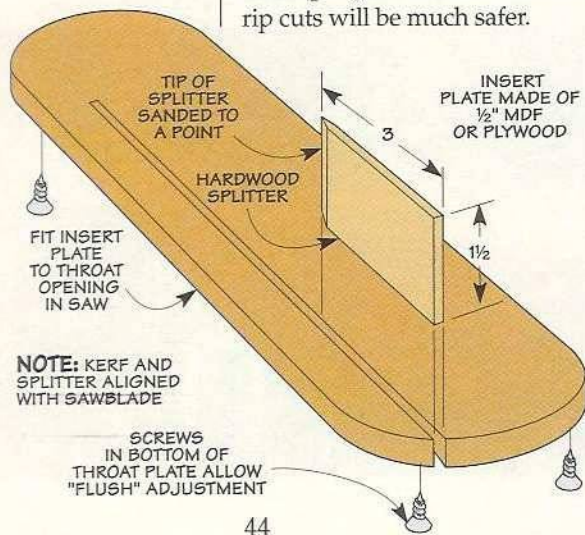
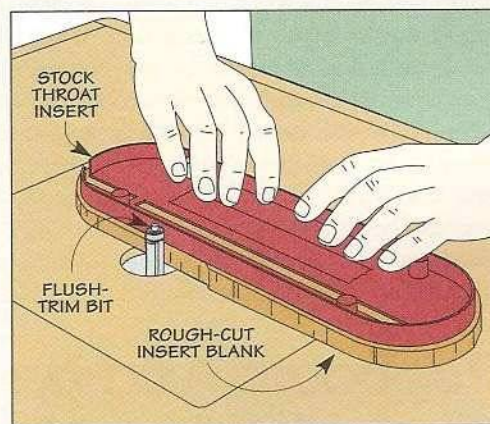



**Easy to Make.** Adding this basic splitter to your saw is a pretty easy task (far left drawing, opposite page). You start by making a new throat insert for the saw out of 1/2" MDF or plywood. To do this, I simply carpet tape the stock insert to a rough-cut blank and then flush trim a new, perfectly sized insert (right drawing, opposite page).

You can start cutting the kerf slot by putting the insert in place and raising the blade up through it. But to complete the cut, you'll need to set up the rip fence. Then you can cut the splitter to fit, taper the front end, and glue it in place.

### USE A FEATHERBOARD

I don't think you can ever have too much control over the workpiece when making a rip cut. But since three hands aren't an option, what I

like to do is add an extra set of "fingers" to the saw with a lock-in featherboard, like the one shown below.

**Continuous Pressure.** A featherboard takes over the responsibility of keeping the workpiece snug to the rip fence. With firm, continuous pressure the workpiece can't wander away from the fence. And since the fingers of the featherboard only allow movement in one direction, the chance of the stock being kicked back is reduced.

To do its job well, the featherboard should apply pressure in the right spot and provide the right amount of "push." To avoid pinching the saw kerf closed, you want to position the featherboard just in front of the blade. And then adjust the tension so that it doesn't take too much effort to push the workpiece past the blade.

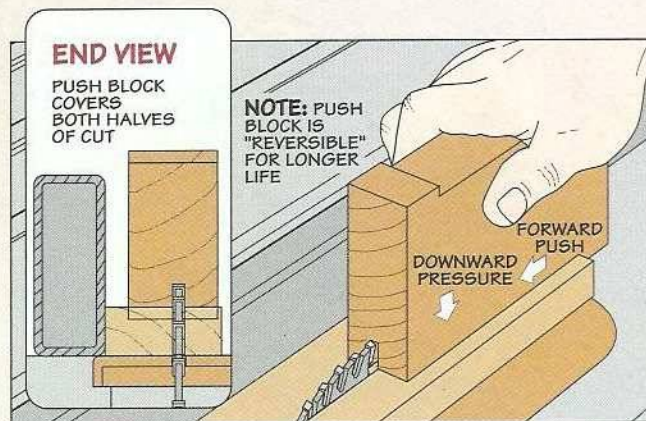
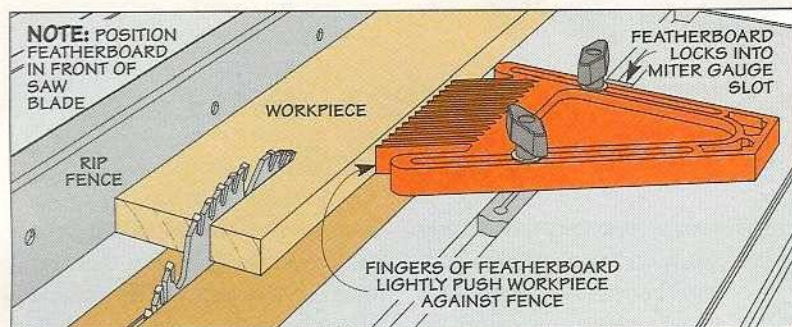

### A GOOD PUSH BLOCK

When ripping stock on the table saw, a good push block isn't optional, it's a must. And the simple 2x4 scrap push block shown in the drawing above is my top choice.

**Why?** This push blocks helps you maintain solid control and avoid any chance of kickback by doing three things. First, the thick "heel" of the block provides a solid, steady push. And then along with a forward push, this design also lets you apply the right amount of downward force needed to keep the workpiece flat on the saw table.

And maybe best of all, as you can see in the drawing above, this push block can ride right over the saw blade. This means you always have full control of both pieces and the job is made much safer.

## Safe Bevel Cuts

Ripping a clean, beveled edge on a workpiece isn't difficult, but there's definitely a right way and a wrong way to go about it.

The correct way to make a bevel cut is shown in the photo at right. Here you see that the saw blade is tilted away from the rip fence. The two drawings at far right give you the idea. The upper drawing (wrong way) shows that when the blade angles toward the fence, the workpiece is completely trapped. If the workpiece lifts slightly off the table, it's pinched between the blade and fence and then kicked back. When you make bevel cuts as shown in the lower drawing, neither workpiece will be trapped.

To make bevel cuts the right way, you may have to move the rip fence from the usual right side of the blade to the left side (this depends on the tilt direction of your saw). But cuts without the chance of kickback are worth the effort.

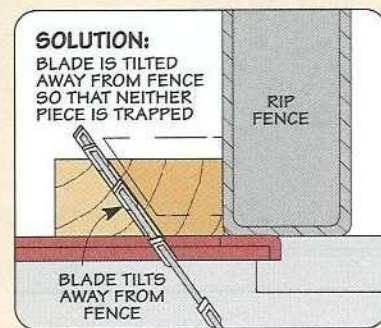
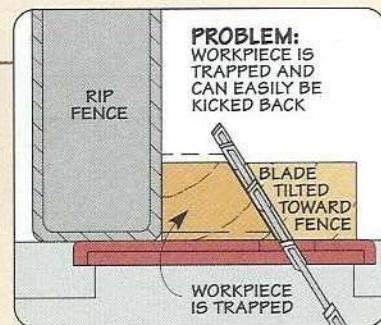
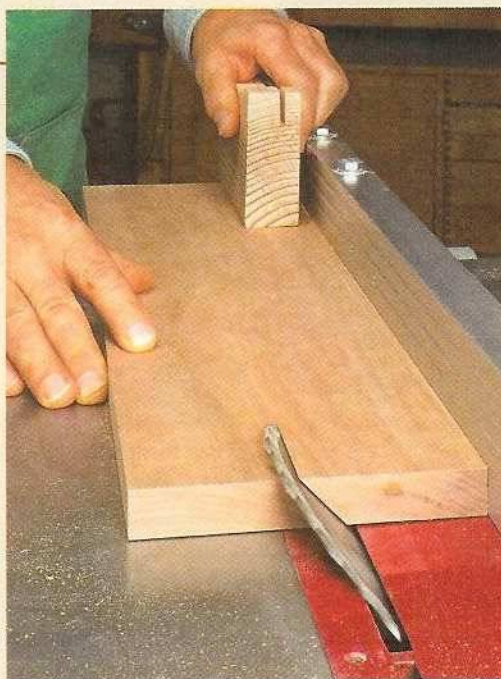



# zero-clearance Throat Inserts

Replacing your stock insert with a zero-clearance insert is an easy upgrade for cleaner cuts.

■ I've found that one of the quickest and easiest ways to get better results from your table saw is to install a zero-clearance throat insert when the job calls for it. Unlike the stock metal throat insert that comes with your saw, a zero-clearance insert gets "up close and personal" with the saw blade (photo above). And there are a couple of advantages to this tight fit between the blade and the saw insert. No gaps around the blade means that the edges of the cut are always "backed up" by the insert below. This leads to much cleaner,

chip-free cuts, especially when using a dado blade on "chippy" plywood.

A second benefit is added safety. With a zero-clearance insert in place there's no chance of a cutoff being trapped between the blade and insert opening and being kicked out. This protects the blade, the saw, and you from damage.

**Right Insert, Right Saw.** Buying an after-market table saw insert isn't a one-size-fits-all proposition. Most have ways to "tweak" the fit to the opening in your saw, but you'll need to start with an insert

sized to fit your particular brand and model. The manufacturers have taken care of this by making a variety of inserts to fit different types of saws. All you need to do is get the right insert for your saw.

Even though all zero-clearance inserts have one basic task, you'll find a lot of differences between the available inserts. So I'll give you a little help by taking a look at a handful. You'll find sources for all the inserts shown here on page 51. Another option is making your own insert, as shown on page 44.

Price  
\$13 - \$15

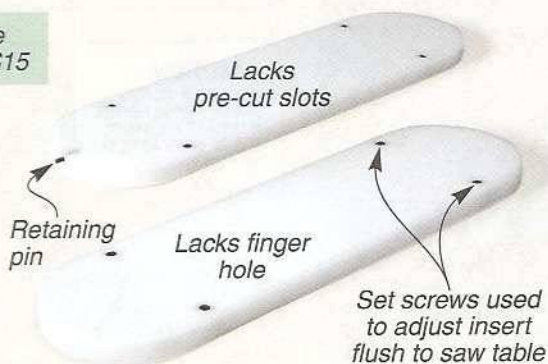

## UHMW PLASTIC

If you're looking for a simple, bare-bones throat insert, the UHMW (Ultra High Molecular Weight) plastic insert shown at left might be your best bet. UHMW plastic is a tough, dense, and very stable material that's almost friction free, so it's great for table saw insert duty. It won't hurt your saw blade or melt from the heat

and once installed, the thick insert will stay dead flat.

But when it comes to adjustment and installation features, you'll only get the basics. Four set screws threaded into the plastic allow you to adjust its height. But the lack of a pre-cut starter kerf might make the installation more difficult.



## THE LEECRAFT

I like to think of the melamine-coated phenolic insert shown at right as the standard workhorse in the lineup. It has everything needed to do the job well and make it easy to use.

It starts with a smooth, stable surface created by the 1/2"-thick, solid phenolic plate. The insert can be quickly adjusted flush to the table with four easy-to-reach

screws. A second set of screws, one in the end and one on the side, allows you to eliminate any play in the opening for a snug fit.

Flip the insert over for a look at the underside and you'll find a narrow "starter" slot positioned directly over the blade. This slot provides the clearance needed for installation on some saws.

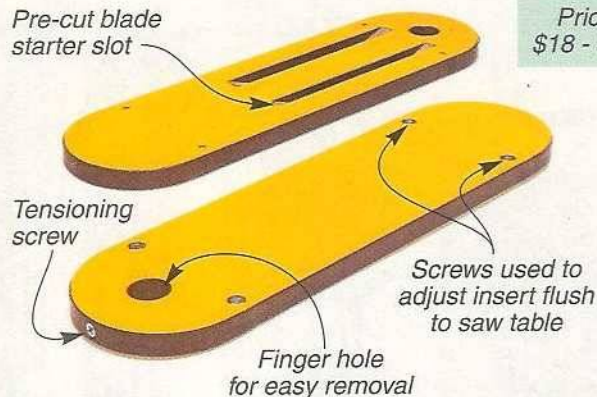

Price  
\$18 - \$20

## THE WOODHAVEN INSERT

Woodhaven takes another route by making their inserts out of 3/4"-thick melamine-coated MDF. The idea here is that MDF is less abrasive on your saw blades, so they'll stay sharp longer. This makes sense and MDF shouldn't give you problems with flatness or stability.

This insert comes with all the standard features — set screws to adjust the height, two screws in the

edge to fit it snugly to the opening and a retaining clip to lock the back end down. But the difference here is that all this hardware has to be installed by the user.

And don't be thrown by the complicated look of the underside. You'll find a starter slot for the blade and a splitter, but the rest of the cutouts simply allow the thicker plate to sit flush to the table.

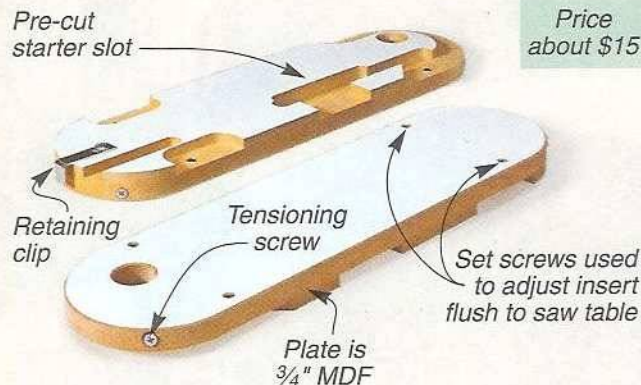

Price  
about \$15

## THE BETTERLEY TRU-CUT

When you take a good look at the *Tru-Cut Blade Insert System* at right, you quickly see that it's a cut above the rest. This two-part insert consists of a precisely machined aluminum insert plate that holds replaceable phenolic kerf inserts. The advantage to this approach is that once the aluminum insert plate is installed in your saw, it becomes permanent. You'll only be changing out the kerf inserts, saving yourself effort.

And when it comes to bells and whistles, you'll find them all. First off, two spring-loaded ball plungers on the side of the plate, hold it rattle-free in the table opening. Then two separate sets of set screws allow you "flush out" both the insert plate and the kerf inserts. You'll even find a slot for use with a splitter. The only downside I see to the *Tru-Cut* is the cost, about \$80 with one kerf insert.

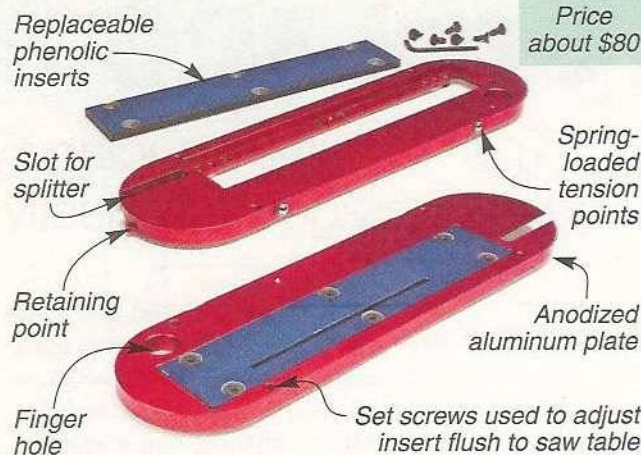

Price  
about \$80

## Shop Tip: Cutting a Slot

Once you've picked up a new throat insert, the next step is to put it to work on your table saw. And there's one thing about this that needs a little bit of explanation.

To install the insert, you'll first have to crank the blade down to its lowest point. Then you can make any adjustments needed to fit the insert snugly in the opening and flush to the table surface.

Now, the trick is to safely cut a slot for the blade. The photo at right shows a good way to do this. A scrap of 2x4 is clamped to the rip fence, snug to the table and positioned over the side of the insert. If the back end of your fence doesn't lock down, clamp it to the table. The 2x4 will hold the insert down as you slowly raise the spinning blade to the desired height.





# ULTIMATE Garage

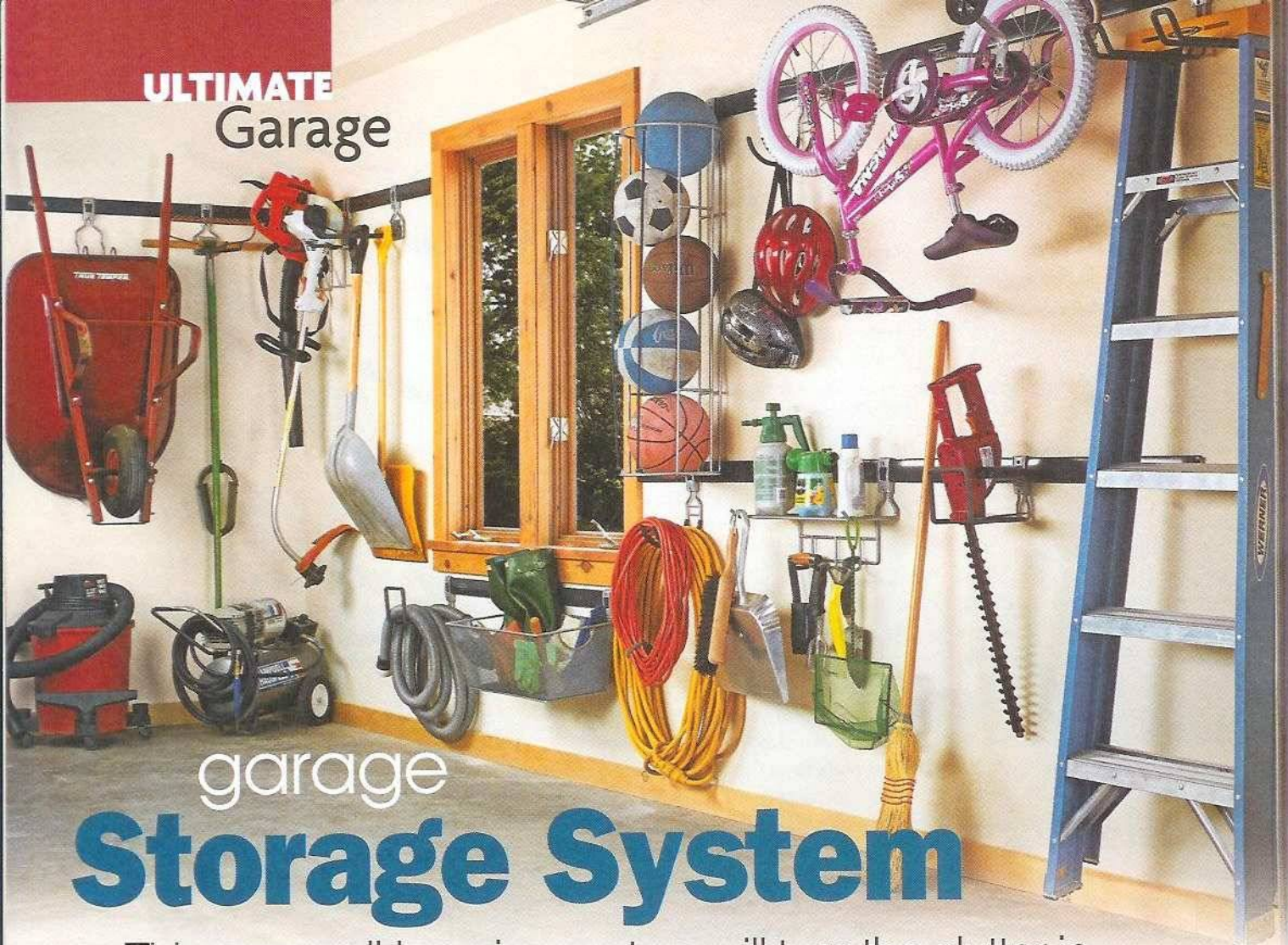

## garage Storage System

This new, wall-hanging system will turn the clutter in your garage into a neatly organized storage area.

- Have you ever noticed how most garages seem to attract stuff like a magnet? Ladders, yard tools, bicycles, sports equipment, camping gear — anything and everything that you don't want to drag inside the house seems to get tossed in the corner of the garage. And while there are all sorts of garage storage products on the market, the trick has always been to find one that's flexible enough to handle all your

storage needs. But the new *FastTrack* garage storage system by *Rubbermaid* (see photo above) may just meet that challenge.

Now, you might be a little skeptical about a garage storage system that's made by a company known for plastic food containers. (I know I was.) But don't let that fool you. After trying out the *FastTrack* system, I was quickly sold on it.

**Track.** As the name implies, the heart of the *FastTrack* system is a metal track that mounts to the wall. A heavy, molded plastic cover snaps over the rail. And a lip on both the top and bottom edges of this cover allows you to quickly snap hooks and hangers in place anywhere along the track, just like you see in the photos at left.

**Snap and Lock.** After mounting the *FastTrack* to the wall, a plastic cover slips over the track. Then various hangers simply fit over the track and lock in place. To remove a hanger, just lift up to unlock it from the track.

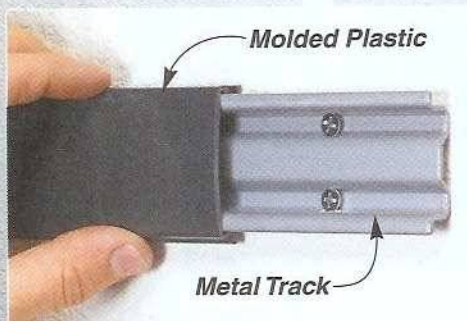



The track sections are available in two different lengths — 56" and 88"-long. Each track is pre-drilled to mount to walls with either 16" or 24" stud spacing. And once they are screwed securely to the wall studs, each track is capable of supporting up to 1,750 lbs. (according to the manufacturer).

**Hangers.** While the track may be the backbone of the system, it's the wide variety of hooks and hangers that make *FastTrack* so versatile. There are over a dozen different types of hangers — many designed for specific applications. (A few of them are shown in the photos on this page and the box below.) There are hangers designed for extension cords, hoses, ladders, basketballs, and bicycles. There's even a two-piece holder that's designed for hanging up a wheelbarrow.

Although the hooks have different shapes and functions, they share some common features. Each one locks onto the track without any tools. So it's an easy matter to reconfigure your storage space whenever you want by simply moving the hangers to a different spot on the track. Plus, mounting holes in each hanger allow you to attach it directly to the wall if you choose not to use the *FastTrack* rail.

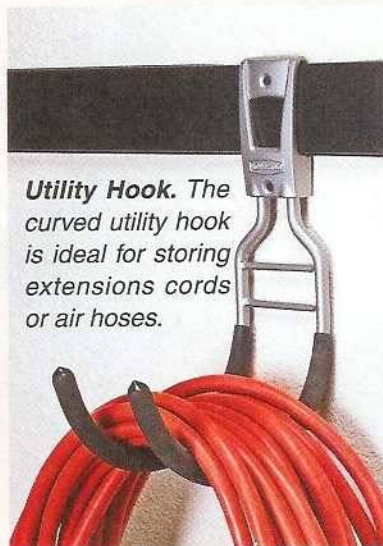

**Utility Hook.** The curved utility hook is ideal for storing extensions cords or air hoses.

The hangers are made out of heavy-gauge steel wire, with an epoxy powder-coated finish that looks great and resists rust. And the ends of the hangers are cushioned with a rubber-like material to protect the items you're storing.

Another feature that I really like is the fact that some of the longer hangers fold up out of the way when they're not in use. This way, you don't have to worry about accidentally bumping into one.

**Availability.** *Rubbermaid* offers a *FastTrack* starter kit that includes one 56"-length of track and three different hangers for under \$50.

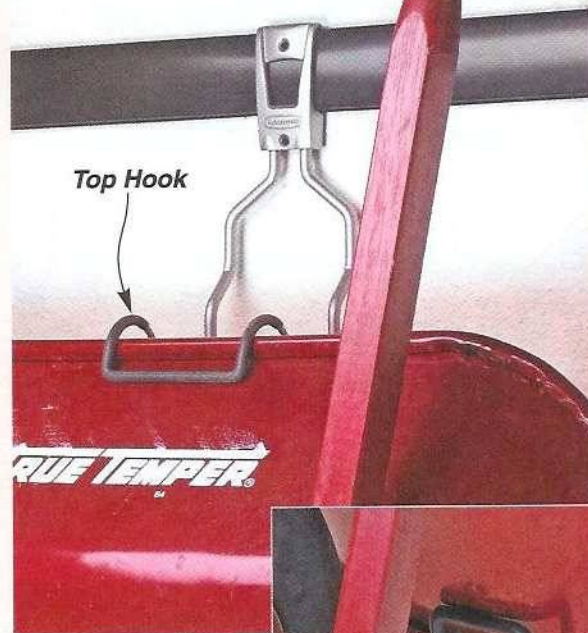

**Top Hook**

▲ **Wheelbarrow Rack.** Wheelbarrows are notorious space hogs. This rack gets the wheelbarrow up off the ground and onto the wall.

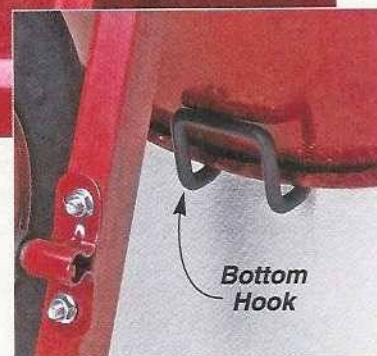

**Bottom Hook**

But all the *FastTrack* components are also sold individually, allowing you to purchase just what you need to customize the system for your garage. To find out where you can get this system, see page 51. 🐶

## Accessories: Shelves and Baskets



▲ **Mesh Storage Basket.** *Rubbermaid* offers two sizes of mesh baskets which are perfect for storing gloves, boots, or other apparel.

The various hooks that are available for the *FastTrack* system are great for things like extensions cords, bicycles, and rakes and shovels. But some things just don't lend themselves to being stored on a hook. For items such as these, *Rubbermaid* offers a couple of sizes of wire baskets and a small, hanging shelf (see photos at left and right).

Like the other *FastTrack* hooks and hangers, these accessories mount directly to the wall track. *Rubbermaid* also makes a set of vertical shelf standards that allow you to add your own shelves for even more storage.



▲ **Three-Hook Shelf.** With a wire shelf and three hooks below, you can store a variety of items in a small space.





questions from  
Our Readers

success with  
**Threaded Inserts**

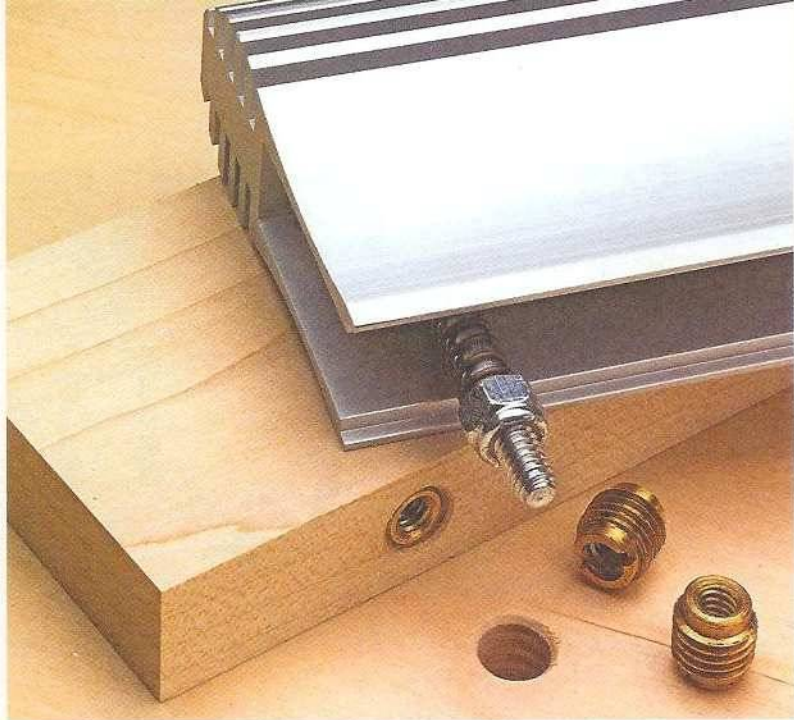

I was building a jig recently that required the installation of a pair of threaded inserts. After drilling the holes, installing the inserts was a difficult process and I ended up splitting the wood. Are there basic guidelines on installing an insert, such as how big the hole should be?

Gary Lohr  
via email



▲ **Insert Tools.** A purchased (top two tools) or shop-made installation tool (bottom) is the best way to get good results.

■ Threaded inserts are must-haves in my shop. I keep them on hand for building jigs and fixtures I need to adjust easily. And they come in just as handy for building and assembling furniture projects.

The challenge with an insert is installing it without any problems. To do this, I follow a few simple steps — size the hole properly, prepare the hole for the insert, and then install the insert straight and flush.

**Sizing the Hole.** The first step is to properly size the hole for the insert. The chart you see below provides a good starting point for determining the size of the hole you'll need to drill. In most cases, I

drill the hole to match the size of the insert body. The problem here is that in some materials (like hard maple) this may not provide enough "give" for the threads as you screw the insert in place.

To prevent the workpiece from splitting, I like to increase the hole a  $\frac{1}{32}$ " (or even a  $\frac{1}{16}$ "). Although this makes the insert easier to install, it doesn't provide as much material for the threads to bite into. In most cases, I find it's usually a good idea to drill a test hole in a scrap piece of the same material, install the insert, and see how well it holds before drilling into my workpiece.

One thing that's easy to forget until it's too late is how deep to drill the hole. What you need to keep in mind here is the length of the fastener that will thread inside. You may need to drill the hole deeper in order to provide clearance, as in the drawing below.

**Prepping the Hole.** Once you have the hole drilled, you could install the insert. But I take a little extra time to add a small chamfer to the top edge of the hole.

The reason for this is simple. As you install an insert, the knife-like threads have a tendency to "lift" the material around the edges of the hole. With a chamfer, you end up with a smooth, clean surface.

**Installing the Insert.** All that's left to do at this point is install the insert. Now, don't be tempted to grab a screwdriver and simply drive the insert in place using the slot at the end. It's all too easy to install the insert crooked doing this. And, in some cases, you end up stripping out the slot, ruining the insert and your workpiece.

To get the best results, I like to use an installation tool that threads or locks securely to the insert (see margin). This makes it easy to drive the insert in place by hand so it goes in straight and ends up flush with the surface of the workpiece. (Plus, you can install the insert with the slot down for a cleaner look.)

Since I use inserts frequently, I like to use the installation tool you see in the photo above (see margin on opposite page for sources). This tool allows you to install  $\frac{1}{4}$ " and  $\frac{5}{16}$ " inserts quickly and easily with nothing more than a wrench. 🛠️

INSERT SIZE	HOLE SIZE	
	Softwood & Laminate Materials	Hardwood
8-32	$\frac{19}{64}$	$\frac{5}{16}$
$\frac{1}{4}$ -20	$\frac{3}{8}$	$\frac{13}{32}$
$\frac{5}{16}$ -18	$\frac{1}{2}$	$\frac{19}{16}$
$\frac{3}{8}$ -16	$\frac{1}{2}$	$\frac{19}{16}$

**NOTE:** Sizes shown are for typical brass inserts. The sizing of steel inserts is less consistent due to style and thread configuration. It's best to make a test installation when using any steel insert.

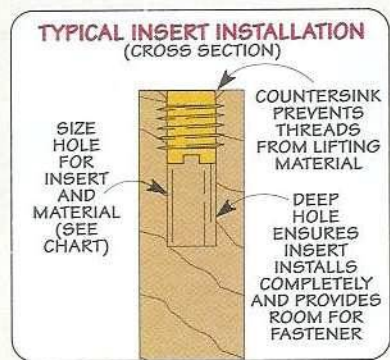



# Sources

## MAIL ORDER SOURCES

### ROUTER TABLE & ACCESSORIES

Building the basic router table shown on page 18 doesn't require much hardware. I picked up a piano hinge at a local hardware store, along with the carriage bolts, locknut, and washers. If you have trouble locating knobs, *Rockler* carries  $\frac{3}{16}$ " T-knobs (71514).

**Adding the Stand.** If you decide to build the router table stand with shelves, the only other hardware you'll need is a set of shelf pin supports. The twelve pins (22773) I used came from *Rockler*.

For the router table stand with the door and drawers, you'll only need four shelf pins, a pair of *Rockler* spring hinges (28845), and a few screws for the drawer runners.

**Router Table Accessories.** The accessories (or similar versions) shown starting on page 8 are available at most woodworking stores, see margin for sources.

*Rockler* carries the miter track (63018), T-track (21746), and dust port (35317) shown on page 25. They also have aluminum insert plates. You can buy a blank plate (35863) or order one pre-drilled to match specific routers.

If you use a *Rockler* plate, an easy way to create the opening in your router table is to use their template (26505) and  $\frac{1}{2}$ " pattern bit (33536).

### AFTER-MARKET MITER BARS

The article on page 12 features after-market miter bars you can use to build your own jigs and fixtures. Both the *Incra* and *Kreg* bars are available from the *Woodsmith Store*. The margin also contains contact information for ordering the *Rockler* and *Woodhaven* miter bars, as well as sources for ordering material to make your own miter bars.

### BRAD POINT BITS

You can find brad point bits at many hardware stores. But to get high-quality bits, a woodworking supplier is a better choice.

The *Woodsmith Store* carries *Fisch* brad point bits. *Lee Valley* and *Woodcraft* offer individual and sets of quality brad point bits as well.

### HARDWARE STORAGE

You can probably find the piano hinge, door pulls, and aluminum bar stock for the hardware cabinet on page 28 at any hardware store.

*Lee Valley* carries the magnets (99K31.03), cups (99K32.53), and washers (99K32.63) used to keep the doors open or closed.

The small storage bins (Model 30210) are made by *Akro-Mils* (see margin). These storage bins (or similar ones) are available at many hardware stores and home centers.

### TABLE SAW MITER SLED

Besides a few pieces of hardware, the miter sled requires flange bolts (33965), T-track (4502024), and knobs (23804) available from the *Woodsmith Store*. They also carry the *Kreg* miter bars (273736). The anti-slip tape (JT-31009) came from *Reid Tool*. For the fence extensions, you'll need another piece of T-track, four  $\frac{1}{4}$ " threaded inserts, studded knobs (23838) and a piece of aluminum angle.

### TABLE SAW INSERTS

Replacing the insert in your table saw with a zero-clearance insert is one of the best ways to improve the quality of the cuts you make. Table saw inserts are available from a number of sources (see margin). All you'll need to know before ordering one is the make and model of your saw.

### THREADED INSERTS

Threaded inserts are must-have pieces of hardware for making jigs and fixtures as well as knock-down projects. The tricky part can be installing them.

The *Woodsmith Store* (see margin) carries a wide variety of threaded inserts. And they have a handy jig (721375) that makes installing  $\frac{1}{4}$ " and  $\frac{5}{16}$ " inserts a snap. 

## ShopNotes Binders

Keep your issues organized!

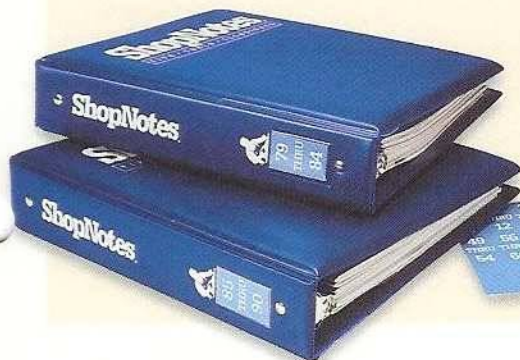

As you build your *ShopNotes* library, here's a way to keep your issues organized. Each binder features durable vinyl covers and easy-to-read perforated number tags. Snap rings with a quick-open lever make it easy to insert and remove issues. And there's an extra pocket inside for storing notes. Each binder holds a full year (6 issues) of the new, expanded *ShopNotes*.

Visit [www.ShopNotes.com](http://www.ShopNotes.com) to order these binders, or call 1-800-444-7527.

### ShopNotes Binder

○ 701950-SN85 (Holds 6 issues).....\$12.95



### Woodsmith Store

800-444-7527

*Insert Installation Jig, Knobs, Miter Bars, Router Table Accessories, Shelf Supports, Storage Bins, Table Saw Inserts, Threaded Inserts, T-Track*

### Rockler

800-279-4441

[www.rockler.com](http://www.rockler.com)

*Miter Bars, Miter Track, Router Insert Plates, Router Table Accessories, Spring Hinges, Table Saw Inserts, Threaded Inserts, T-Knobs, T-Track*

### Akro-Mils, Inc.

800-253-2467

[www.akro-mils.com](http://www.akro-mils.com)

*Storage Bins*

### Amazon

[www.amazon.com](http://www.amazon.com)

*Rubbermaid FastTrack Garage System*

### McMaster-Carr

630-600-3600

[www.mcmaster.com](http://www.mcmaster.com)

*Aluminum Angle, UHMW & Aluminum Bar Stock*

### Lee Valley

800-871-8158

[www.leevalley.com](http://www.leevalley.com)

*Brad Point Bits, Router Table Accessories, Table Saw Inserts*

### Kreg Tool Company

800-447-8638

[www.kregtool.com](http://www.kregtool.com)

*Miter Bars, Miter Track*

### Woodcraft

800-225-1153

[www.woodcraft.com](http://www.woodcraft.com)

*Brad Point Bits, Router Table Accessories, Table Saw Inserts*

### Reid Tools

800-253-0421

[www.reidtool.com](http://www.reidtool.com)

*Anti-Slip Tape, Knobs*

### Woodhaven

800-344-6657

[www.woodhaven.com](http://www.woodhaven.com)

*Miter Bars, Table Saw Inserts*

### Rubbermaid, Inc.

888-895-2110

[www.rubbermaid.com](http://www.rubbermaid.com)

*FastTrack Garage Systems*

### U. S. Plastic Corp.

800-809-4217

[www.usplastic.com](http://www.usplastic.com)

*Akro-Mils Storage Bins*

### Peachtree Woodworking

888-512-9069

[www.ptreeusa.com](http://www.ptreeusa.com)

*UHMW Table Saw Inserts*



## Scenes from the Shop



• You'll be guaranteed perfect miter cuts time after time with this all-new miter sled. With optional fence extensions and stop blocks, you can cut longer workpieces to identical length. Detailed plans start on page 34.

• Keeping track of small items and hardware is a challenge. This shop-built organizer makes it easy. And the storage bins can be removed so you can work away from the shop. Step-by-step instructions start on page 28.

