

**ROUTER TABLE
TECHNIQUE**

RAISED PANELS MADE EASY

3 Basic Bits Are All You Need

Vol. 16 Issue 92

ShopNotes®

**BEFORE & AFTER
SHOP
MAKEOVER**

**Transform Your
Work Space Into
The Ultimate
One-Wall
Workshop!**

BEFORE

PLUS!

**7 EASY-TO-BUILD
TABLE SAW
ACCESSORIES**



**LOOK INSIDE
MORE PROJECTS, TIPS, & TECHNIQUES!**

Contents

Features

storage solutions

One-Wall Workshop  **16**

Turn any wall into a compact, easy-to-use workcenter. Starting with purchased cabinets, you can customize the project with pegboard storage panels, open tool cubbies, beefy benchtops, and a flip-up workbench.

hands-on technique

Rabbeted Case Construction **28**

Building a basic shop cabinet doesn't have to be a challenge. With ordinary rabbet joints, you can create rock-solid cases in no time.

weekend workshop

Cleanup Center **30**

Your shop will stay neat and tidy when all your cleaning supplies are organized and close at hand in this handy storage center.

best-built jigs & fixtures

Dust-Free Blade Cover **36**

Getting tired of dealing with all the dust from your table saw? This shop-made blade cover will put the dust in its place.

Departments

Readers' Tips **4**

router workshop

Raised Panels on the Router Table **8**

With just an auxiliary fence and ordinary router bits, you can quickly create great-looking raised panels at your router table.

materials & hardware

Heavy-Duty Wall Anchors **10**

Use these simple fasteners to securely and easily attach wall-mounted cabinets.

jigs & accessories

Plywood Edging Bits **12**

Hiding the edges of plywood is a snap with this easy-to-use router bit system.

Shop Short Cuts **14**

Shop-tested tips and techniques to solve your woodworking problems.

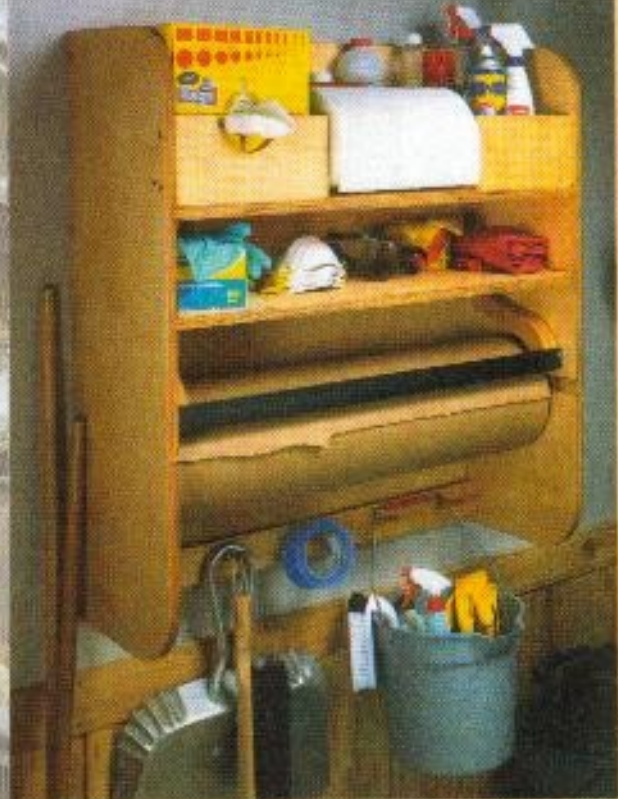

Cleanup Center

page 30



Router Table Raised Panels page 8

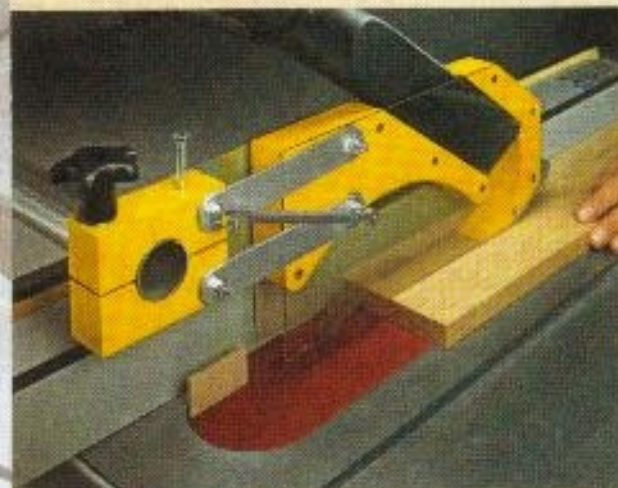

Dust-Free Blade Cover

page 36

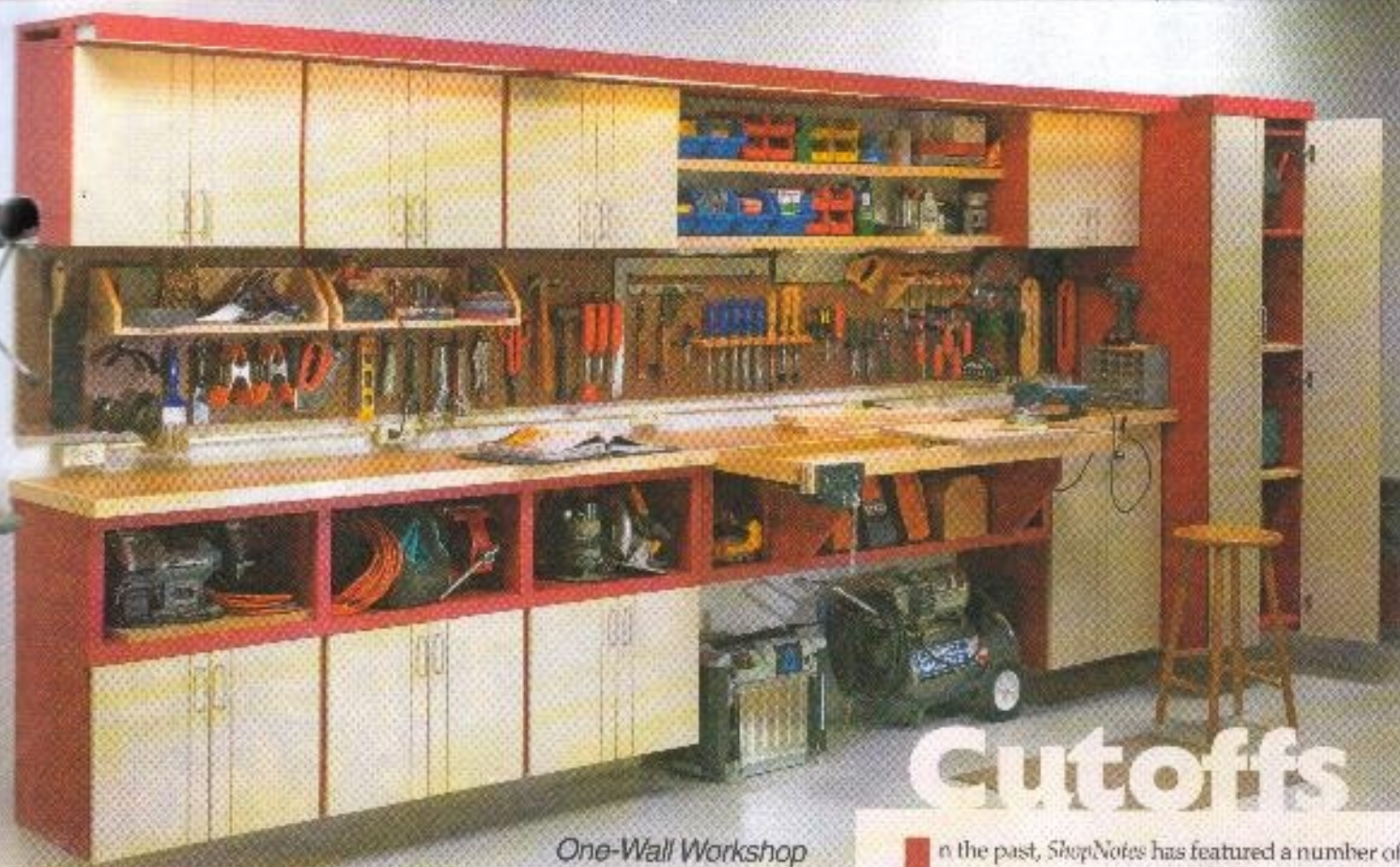

One-Wall Workshop
page 16

Cutoffs

hands-on technique

Working with Dimensional Lumber _____ 34

From lumberyard to your next project — here's how to get the most out of dimensional lumber.

in the shop

Pre-Fab Shop Cabinets _____ 40

Inexpensive, manufactured shop cabinets can make organizing your shop a breeze.

setting up shop

7 Must-Have Table Saw Accessories _____ 42

Work safer, faster, and more accurately with these handy, shop-built jigs and accessories.

mastering the table saw

Snug-Fitting Tenons _____ 46

A dado blade and the right technique are all you need to cut perfect-fitting tenons every time.

great gear

Miter Saw Accessories _____ 48

Get better results and improved accuracy from your miter saw with these great upgrades.

Q&A _____ 50

Sources _____ 51

In the past, *ShopNotes* has featured a number of different ways to help make your shop better organized. Typically, this involved some sort of shop-built cabinet system. The only downside to making a complete set of your own cabinets is it can be a bit time-consuming.

So this time we took a different approach by starting with easy-to-assemble, manufactured storage cabinets. Then we designed a few custom options to make the cabinets work even better. For starters, we built easy-access, under-counter tool cubbies, a space-saving flip-up workbench, and overhead lighting. Finally, we applied a sharp-looking, two-tone paint finish for protection.

The best thing about this project is you have lots of options, so you can easily make it fit your shop space and your needs. For more on creating your own one-wall workshop, be sure to check out the article beginning on page 16.

Tom



This symbol lets you know there's more information available online at www.ShopNotes.com

from our Readers

Tips for Your Shop

Miter Clamping Jig

Cluing and clamping a single miter joint can be a challenge. It's often hard to get the joint lined up and then hold everything in place until the glue dries. To make this task easier, I built the clamping jig you see in the photo above.

As shown in the drawing below, the jig consists of a large base of

plywood to support the pieces to be joined. A pair of triangular-shaped blocks have a tongue at the bottom that slides in a groove in the base cleat to hold the pieces from the side. Sandpaper attached to one edge keeps the workpiece

from slipping. A third triangular block travels on a T-track so it can

be locked in place to secure the joint from the top. Before assembling the jig, I waxed all surfaces to prevent any glue from sticking to the parts. To use the clamping jig, apply glue to the mitered ends. Now you can lay the two pieces on the base with the mitered edges pointing toward the bottom edge of the jig. Be sure to carefully center these pieces on the T-track.

Next, slide the inside clamping block against the workpieces and tighten the knob. Then move the outside clamping blocks into position and clamp them in place with a bar clamp. For maximum pressure, position the bar clamp near the base of the clamping blocks.

Now just let the jig hold the pieces in place until the glue dries.

*Stephen Ehrich
Louisville, Kentucky*

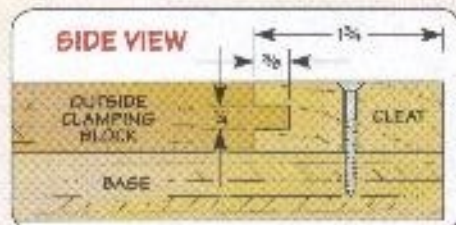
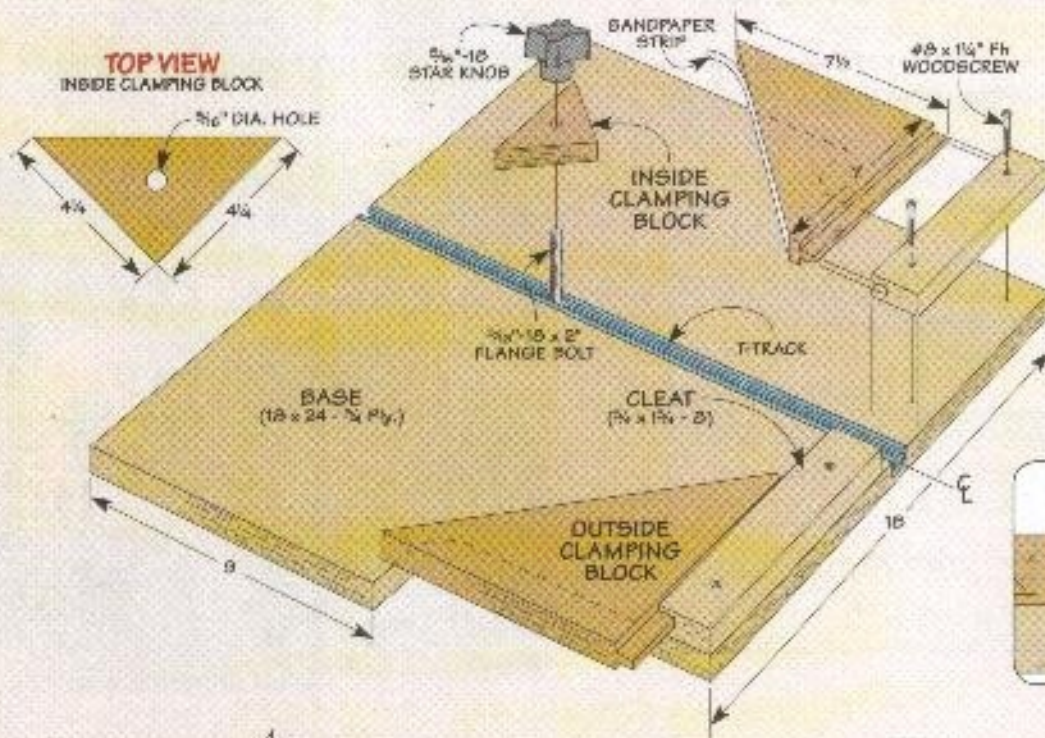

Nozzle Wedge

The pull-up nozzle on some glue bottles helps dispense the glue and keeps it from hardening when not in use. But dried glue usually accumulates inside the nozzle, making it hard to open the nozzle. I often resort to using pliers to get it open. But that tends to tear up the nozzle, eventually making it unusable.

To solve this problem, I built the simple tool shown in the photo at right to help lift up the nozzle. The tool has a slot at one end that's sized to fit the nozzle. It's long so you can use it as a lever to easily lift the nozzle without doing any damage to it.

The nozzle lifting tool can be quickly built from a piece of $\frac{3}{4}$ "-thick hardwood. Start by drilling a hole at one end the same size as the nozzle of the bottle.



Then use your band saw to cut away the waste to form the notch. Then cut a bevel at the end with the notch, as shown in the drawing below. Finally, round over all edges of the wedge with sandpaper.

*Leon Davis
Merlin, Oregon*

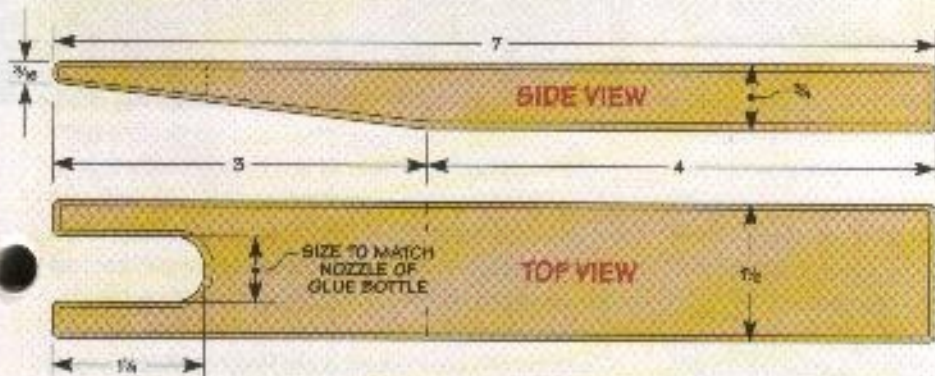

Submit Your Tips

If you have an original shop tip, we would like to hear from you and consider publishing your tip in one or more of our publications. Just write down your tip and mail it to: *ShopNotes*, Tips for Your Shop, 2200 Grand Avenue, Des Moines, Iowa 50312. Please include your name, address, and daytime phone number (in case we have any questions). If you would like, you can FAX it to us at 515-282-6741 or simply send us an email message at: shopnotes@shopnotes.com. We will pay up to \$200 if we publish your tip.

The Winner!

Congratulations to Stephen Ehrich of Louisville, Kentucky. His tip on making a miter clamping jig was selected as winner of the *Porter-Cable* router just like the one shown at the right. The jig makes it easy to clamp up a single miter joint and hold it in position until the glue dries.

To find out how you could win a *Porter-Cable* router, check out the information above. Your tip just might be a winner.



PUBLISHER Donald B. Reschke

EDITOR Terry J. Striffler

MANAGING EDITOR Bryan Nelson

CONTRIBUTING EDITOR Vincent Ancona

ASSOCIATE EDITORS Phil Huber, Ted Baile

ASSISTANT EDITORS Ron Johnson, Mitch Holmes,
Randall A. Masey, Dennis Perkins

EXECUTIVE ART DIRECTOR Todd Lambirth

ART DIRECTOR Cary Christensen

SENIOR GRAPHIC DESIGNER Jamie Downing

SENIOR ILLUSTRATOR Roger Reiland

ILLUSTRATORS David Kallemyr, Peter J. Larson

GRAPHIC DESIGN INTERNS Shelley Cronin,
Kate Roodmyer

CREATIVE DIRECTOR Ted Kraloek

SENIOR PROJECT DESIGNERS Ken Munker,
Kent Wlesh, Chris Fitch

PROJECT DESIGNERS/BUILDERS Mike Donovan,
John Doyle

SHOP CRAFTSMEN Steve Curtis, Steve Johnson

SR. PHOTOGRAPHERS Crayola England, Dennis Kennedy

ASSOCIATE STYLE DIRECTOR Rebecca Cunningham

ELECTRONIC IMAGE SPECIALIST Allen Ruhnke

VIDEOGRAPHERS Craig Rugsdagger, Mark Hayes

ShopNotes (ISSN 1528-8607) is published bimonthly (Jan., March, May, July, Sept., Nov.) by August Home Publishing, 2200 Grand Ave., Des Moines, IA 50312.

ShopNotes is a registered trademark of August Home Publishing. © Copyright 2007 by August Home Publishing. All rights reserved. Subscriptions: Single copy: \$4.95. One year subscription (5 issues): \$27.95. Canadian International: add \$10 per year, U.S. funds.

Canadian Subscriptions: Canada Post Agreement Number 400885. Send change of address information and blocks of undeliverable copies to: P.O. Box 991, Sussex, MB, R1R 9S6, Canada. BN 9437 6478 57.

Periodicals Postage Paid at Des Moines, IA and at principal mailing offices. Postmaster: Send change of address to *ShopNotes*, P.O. Box 37110, Boise, IA 50007-2110.

www.ShopNotes.com

ONLINE SUBSCRIBER SERVICES

- **ACCESS** your account
- **CHECK** on a subscription payment
- **TELL US** if you've missed an issue
- **CHANGE** your mailing or e-mail address
- **RENEW** your subscription
- **PAY** your bill

Click on "Subscriber Services" in the list on the left side of our home page. Menus and forms will take you through any of the account maintenance services you need.

HOW TO REACH US:

FOR SUBSCRIPTIONS, ADDRESS CHANGES
OR QUESTIONS, WRITE OR CALL:

Customer Service
2200 Grand Ave., Des Moines, IA 50312
800-333-5854 8 a.m. to 5 p.m. CT

OR SEND AN EMAIL TO:
orders@shopnotes.com

AUGUST HOME
PUBLISHING COMPANY

Printed in U.S.A.

Edge Trimming Panel Supports

Whenever I use plywood to build a project it usually means having to deal with exposed plywood edges that need to be covered. But you'll find a few challenges to applying edging and making it look great.

Since I want to be sure the edges are completely covered, I like to start with the edging just a hair wider than the thickness of the plywood. Then once the glue dries, the edging can be trimmed flush. I like to use a hand-held router with a flush trim bit to do this. But the challenge is balancing the router on the edge of the plywood to make a clean cut.

To provide stability to the panels while I routed the edges, I used to clamp two panels on edge with 2x4 scraps between them. But accomplishing this always seemed to take more hands than I had to get everything clamped in place. To make the job easier, I made the panel supports shown in the photo at right.

The supports are easy to build and can be made from scrap pieces of stock. I made mine from $\frac{3}{4}$ " plywood.

Each support begins with a long base to provide an area to clamp the support to the workbench. Next, glue up two layers of plywood to create a center divider and attach it upright on the base. This separates the two panels to be trimmed and provides a wide surface for clamping the panels securely in position. Then, to hold the plywood panels in place while I attach the clamps, just add a shorter outside support on either side.

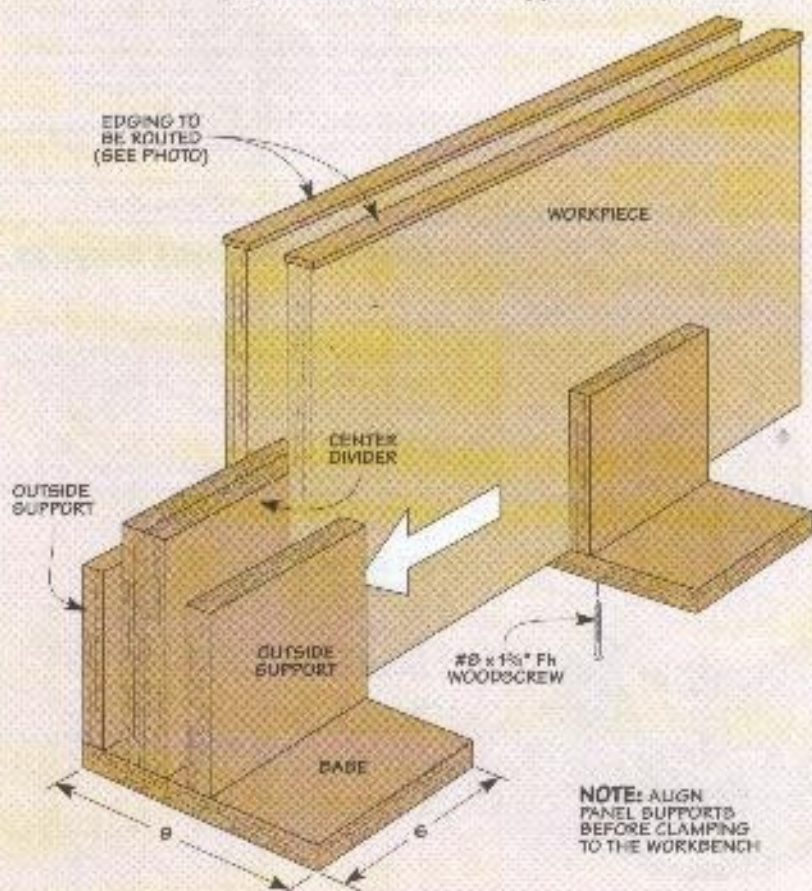

The supports are easy to set up and simple use. All you need to do is align the two supports with one another and then clamp them to your workbench. After slipping a panel between the center divider and each outside support, clamp the panels to the divider at each end, as shown in the drawing below.

Both panels are now securely supported, making it easy to trim the edging flush. Just be sure to rout each panel in a clockwise direction to avoid kickback.

*Benjamin Nelson
West Des Moines, Iowa*

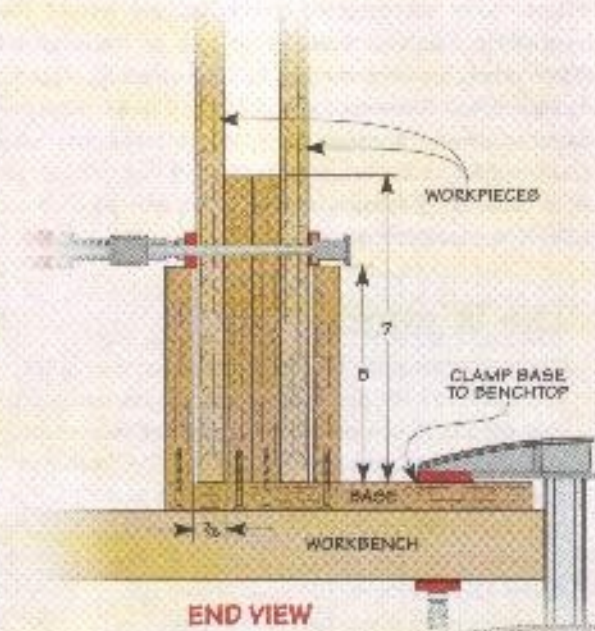

Easy Storage Bins

I've always liked the old pull-out bins you used to find in hardware stores. To duplicate this look, I built the storage bins shown in the photo at right.

The bins have ample room for storing bulk hardware items and keeping the parts in plain view. The pull on the front forms a hollow area underneath the top. This makes it easy to get your fingers under the pull whenever you need to slide the bin out to get at the parts.

The bins are simple to build. And you can make them longer or wider to fit your needs. They're so easy to build you'll want to make a number of them once you start.

Begin by cutting the plywood pieces to width. I used a stop block on my table saw to ensure the pieces were cut to identical lengths. Next, you can cut out the $\frac{1}{4}$ " hard-board sides. Since I wanted to make several bins, I first made a pattern of the sides. Then it was just a matter of using a pattern bit to trim the sides to shape at the router table. This way, all the sides are exactly the same.

Assembling the bins is quick and easy too. Just apply glue to the edges and clamp the parts in place until the glue is dry.

Now all that's left is to fill the bins with hardware. Then you can set them on a shelf or your workbench. Your bulk hardware will always be easily accessible.

Gerald W. Renken
Carlsbad, California



NOTE: ALL PARTS ARE GLUED TOGETHER

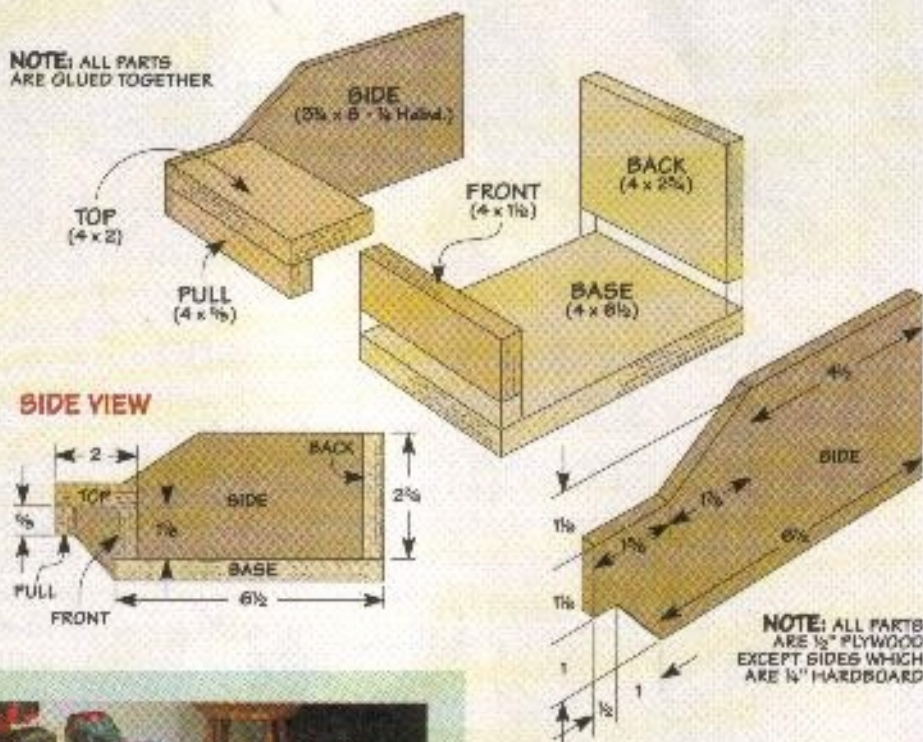

NOTE: ALL PARTS ARE 1/2" PLYWOOD EXCEPT SIDES WHICH ARE 1/4" HARDBOARD

Quick Tips



▲ Robert Moore of Omaha, NE, uses an ordinary rubber band to help control the cord on his router when it's not in use. He simply loops the rubber band over the cord and then places the other end over the handle.



▲ A used file cabinet provides Charles Mak of Calgary, Canada, with storage space for his power tools. The tools are organized and safely stored out of the way until he needs to use them.

FREE TIPS BY EMAIL

Now, you can have the best time-saving secrets, solutions, and techniques sent directly to your computer. Just go to www.ShopNotes.com and click on "FREE Tips by Email" to sign up. You'll receive a new tip by email each week.

router table Raised Panels

With a simple auxiliary fence and a few common router bits, you can make great-looking raised panels.

Solid-wood raised panels are one of those woodworking details that always draws attention to a project, both for their visual appeal and the craftsmanship involved in making them. The router table offers a great option for creating crisp, snug-fitting raised panels, but the drawback can be the pricey, single purpose router bits needed for the job. Well, my solution to this problem is a simple technique that uses only common, inexpensive bits along with an adjustable auxiliary fence to make cleanly routed raised panels.

How It Works. Take a quick look at the photo above and you'll understand how this technique works. The adjustable fence you see is the key. It can be set "square" to the table or tilted up to 15°. This allows you to cut a beveled (or square) border by feeding the panel on edge past a long straight bit. You follow up by routing a decorative shoulder around the bevel cut.

The Setup. As you can see in the drawing at left, the fence is easy to build, so I won't go into the details. But you will need a little explanation of the basic setup of the jig and router table.

The main photo above shows how to set up the router table for the bevel cuts. I start by installing a long straight bit (1¼" to 1½") in the router table. You can then adjust the height of the bit to match the width of the bevel cuts. Note: A bit with a ½"-dia. shank will have less "chatter" and leave a cleaner surface.

The fence is clamped to the table behind the bit. And the fence face is tilted (or square) to match the desired angle of the border cuts. To make the cuts, the panel is fed between the bit and the fence.

To get a smooth, accurate cut, it's important to keep the panel snug to the fence. This is why you

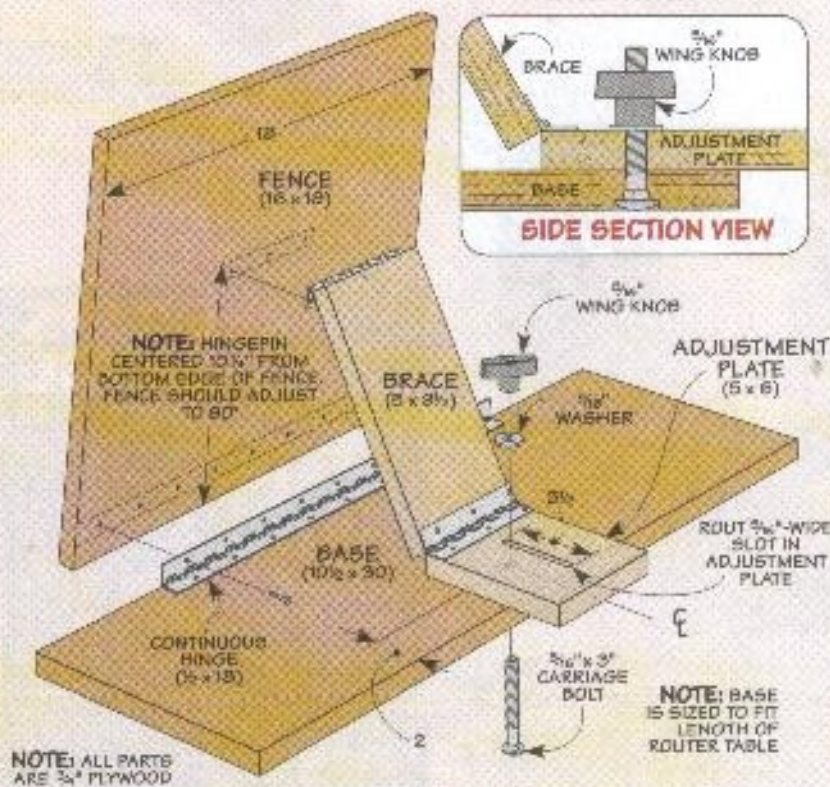

see a featherboard clamped to the table with the fingers riding lightly against the panel. The featherboard is screwed to a spacer block that raises it above the cutting height of the bit. This allows you to position the featherboard directly over the exposed bit to double as a guard. Finally, a brace clamped to the table helps hold everything in place.

Routing Basics. That covers the router table setup. Next, I'll go through the basic technique used to cut a raised panel profile. The drawings at right show how to make a common style. You'll find a couple of different profiles in the photos and drawings below.

First, to get the smoothest surface, you want to cut the bevel with multiple, shallow passes, as shown in Figure 1. To start, position the fence so that the bit will only cut along the outside edges of the panel. Then between passes, unclamp one end of the fence and slide it a little closer to the bit. Initially, you can cut about $\frac{1}{16}$ " deep. As the bit starts to cut "full-length," lighten up to take no more than $\frac{1}{32}$ " at a time.

Left to Right. One very important thing to note is that the panel is fed from left to right. This is opposite the usual feed direction. The reason is that you're cutting on the "back side" of the bit. Don't worry — you're not backrouting and the cut will feel normal.

Ends First. I start with a cut across one end of the panel, moving it slowly but steadily. The featherboard should be pushing the panel firmly against the fence, but not making the feed difficult.

Now, rotate the panel counter-clockwise to cut the adjacent long grain edge. Follow with the opposite end and then finish up with the final long grain edge. Using this sequence, any tearout at the ends of the crossgrain cuts will be removed by the following cut.

Once all four edges have been cut, you can move the fence closer to the bit and repeat the process. You may need to readjust the

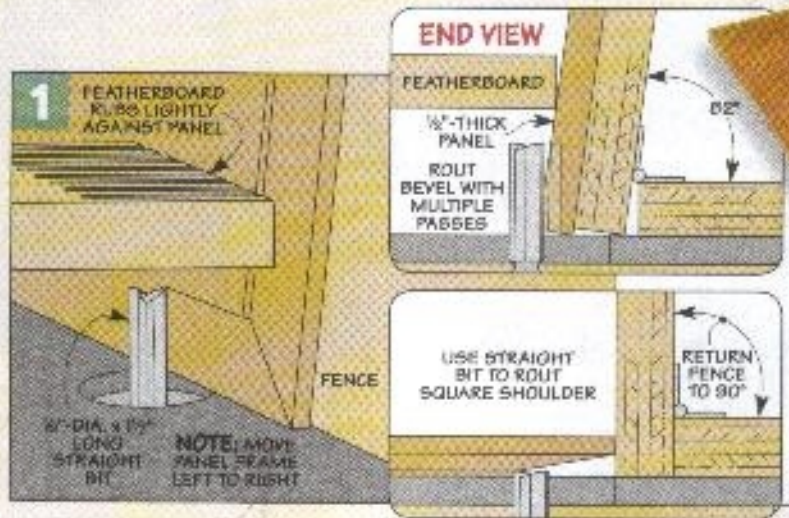

featherboard if the feed starts to get too difficult.

A Snug Fit. The best way to end up with a panel that fits snugly in the frame grooves is to test fit it as you go. So I always have a finished frame piece close at hand. When you get close to your target, the cuts should be "whisker thin." This will give you the cleanest cut and allow you to sneak up on a tight fit. I stop cutting when the panel is still a hair tight in the groove and then fine-tune the fit with some light sanding.

Now, the Shoulder. Making the wide bevel cuts leaves you with "reverse" beveled shoulders. This is easy to remedy and also allows

you to customize the profile. The process here involves carefully cutting a square, chamfered or rounded shoulder. To do this, the panel is passed over the router bit face down, flat against the table.

The goal is to seamlessly blend the two routed profiles. To do this, set the bit height carefully and then sneak up on the final shape by adjusting the fence between passes. You may need to do a little sanding to smooth the transition.

As you can see, there's nothing difficult about this technique. It's a great way to make professional-looking raised panels that will add an extra measure of craftsmanship to your next project.

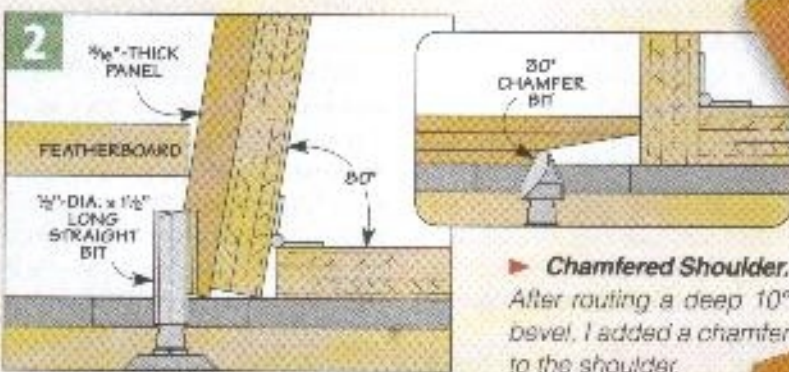

► **Chamfered Shoulder.** After routing a deep 10° bevel, I added a chamfer to the shoulder.

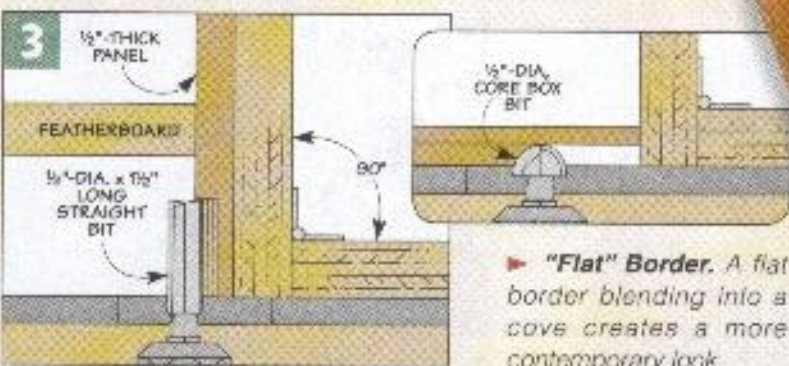

► **"Flat" Border.** A flat border blending into a cove creates a more contemporary look.

▲ **The Classic Look.** A beveled border ending in a square shoulder creates a classic raised panel.

heavy-duty Wall Anchors

Can't find a wall stud?
These fasteners will
solve the problem of
hanging heavy loads.

■ After completing a shop cabinet, I went to hang it on the wall near my workbench — no problem, right? Well, there wasn't a stud in a convenient place to hang the cabinet right where I wanted it. So I made a trip to the hardware store to look for another solution.

I ended up mounting the cabinet using some hollow-wall anchors. These fasteners distribute the weight of a project over a wide area so you don't need to hit a stud.

But not just any wall anchor will do the job. Here's a look at some heavy-duty anchors you can rely on. You should have no trouble

finding them at a hardware store, home center, or you can refer to sources on page 51. (If your shop has solid, masonry walls, you'll want to take a look at the box on the opposite page for a few options.)

TOGGLE BOLTS

One of the most familiar and common anchors you'll find at the hardware store is a toggle bolt, as shown in the photo above. There are a couple of reasons why toggle bolts are so popular. First, they're inexpensive. (The $\frac{3}{16}$ " bolts shown cost about 30 cents.) The second reason for their popularity is that they'll hold a lot of weight (up to 70 lbs. for each bolt).

Downsides. Although a toggle bolt sounds perfect, it does have a few downsides. The first is that they can be tricky to use when mounting cabinets. The wings need to be attached to the screw when it's installed in the wall. So you'll have to insert the screw through

the cabinet back first. Then you can thread the wings on and press them through the hole in the wall, as in the photo above.

This leads me to the other drawback of toggle bolts. If you ever need to remove the cabinet, the wings will fall into the bottom of the stud cavity.

SELF-DRILLING TOGGLE

To address the problems with toggle bolts, you can turn to a self-drilling toggle. This type of anchor has two advantages over toggle bolts. First, the anchor can be driven into drywall with just a screwdriver — without drilling a pilot hole first.

The second advantage is the anchor stays in place without the screw. This makes it easy to mount or reposition the cabinet.

You can see how the toggle works in the photos below. As the screw is driven into the anchor, it tips the toggle free. The threads



Self-Drilling Toggle. With a nose like a spade bit and deep threads, this anchor doesn't require a pilot hole. A screw forces the toggle to flip out and then draws it up tight.



Toggle is tucked inside anchor

Screw tip pushes out toggle then threads in center hole

of the screw then engage the toggle and draw it tight to the back of the wall. Self-drilling toggles are more expensive than toggle bolts (about 75 cents). But they have become a go-to anchor in my shop. About the only downside to self-drilling toggles is that they aren't as strong as toggle bolts. I only use them up to 50 lbs. per anchor.

SNAPTOGGLE

For those times when you want to hang heavy loads without a lot of hassle, consider using a *SnapToggle*, as in the photo above. In my book, it combines the best of a traditional toggle bolt (high load limit — 60 lbs.) with the ease of use of a self-drilling toggle (stays in place).

The three photos at right show how it's installed. Strength and convenience like this come at a price, though. The *SnapToggle* sells for a little more than a dollar.

Armed with any of these anchors, you should have no trouble hanging heavy objects. And they give you the freedom to mount a cabinet right where you want it.



▲ **SnapToggle.** Here's one anchor that won't fall into the wall. The large, thick toggle is held in place by a plastic collar.

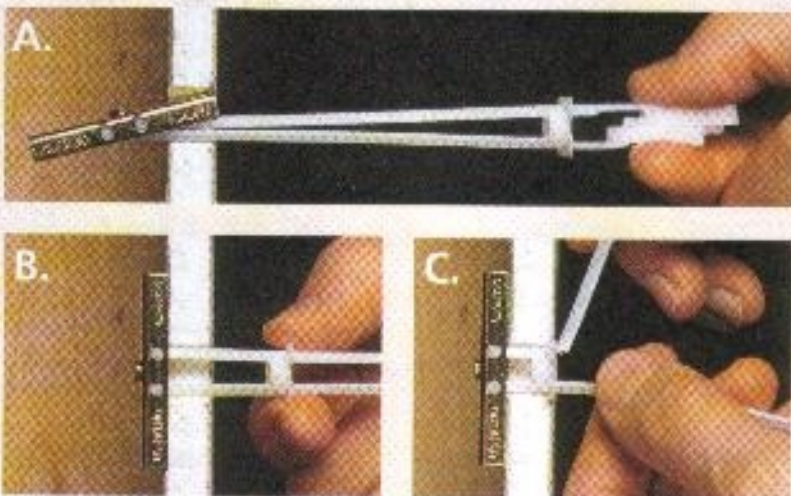

Solutions for: Solid Walls

The anchors shown above work just fine in stud walls. But what if your walls are masonry? Don't worry, here are three great options.

Expansion Bolts. The solution I use most often to provide a sure grip in a solid wall is an expansion bolt. It has a cone at one end that forces three metal fins to expand against the inside of the pilot hole, as in the top photo.

Expansion Inserts. Along the same lines as expansion bolts are expansion inserts (middle photos). They're made from soft metal to conform to the shape of the pilot hole. There are two types: one is designed for use with woodscrews, and the other is a threaded, two-piece insert made for machine screws.



► **Expansion Bolt.** Fold-out fins wedge the bolt inside the pilot hole for a strong grip in solid, masonry walls.

Tapcon Screws. The simplest solid wall anchor is a *Tapcon* screw (bottom). Although it looks similar to a woodscrew, the coating and threads are designed for holding in masonry. The advantage is that you can drill one size hole right through the back of your project and into the wall at the same time.

No matter which of these options you choose, you'll need to drill a properly sized pilot hole (check the package). To do this, you'll need a carbide masonry bit and a corded drill. (A hammer drill works best.)

Expansion Inserts



get a finished look with Plywood Edging Bits

Your router and a couple of bits are all you need to make perfect-fitting plywood edging every time.



■ Plywood is a great material for building projects. But there is a problem — the exposed edges aren't very attractive.

The solution is to glue a strip of hardwood over the exposed edges. But you'll find there are a few challenges when it comes to applying edging.

The strips often slip out of alignment as you clamp them in place. And you usually need to trim them flush with the surface once the glue dries. It's also often

difficult to get a good match with the veneer so the hardwood edging doesn't stand out.

Fortunately, these challenges can be easily met. All it takes is a set of special router bits.

EDGING BITS

Most of the difficulty in applying edging comes as you position and glue the edging strip in place. The *Burgess System* bits you see in the photo at left helps you solve these problems. This system consists of two edging bits for use with $\frac{3}{4}$ "-thick material. A set for $\frac{1}{2}$ " material is also available (sources page 51).

The bit on the left cuts a recess in the edge of a $\frac{3}{4}$ " plywood panel. And the bit on the right makes the matching convex profile on the hardwood edging strip.

These bits provide several advantages. First, the edging self-aligns. This makes it easy to locate the strip and clamp it in place. And there's a lot more surface area for the glue to make a strong bond.

Each piloted bit comes with two .016" steel shims already installed. This setup works for most $\frac{3}{4}$ " plywood. But if your plywood is slightly thinner or thicker, additional .010" copper shims come with

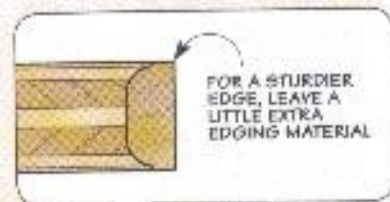
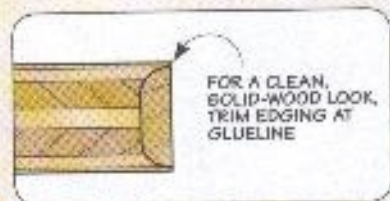

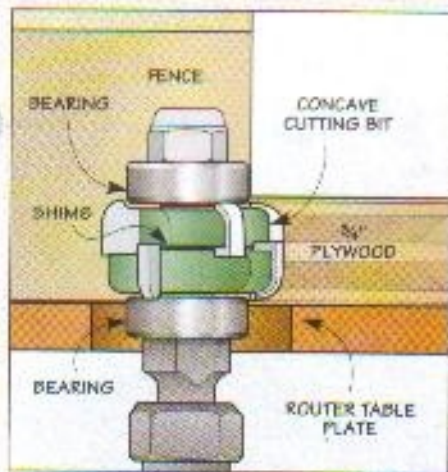

▲ **Concave Plywood Bit.** To leave a thin plywood veneer lip at the top and bottom of the plywood, adjust the bit by adding or removing shims as necessary.

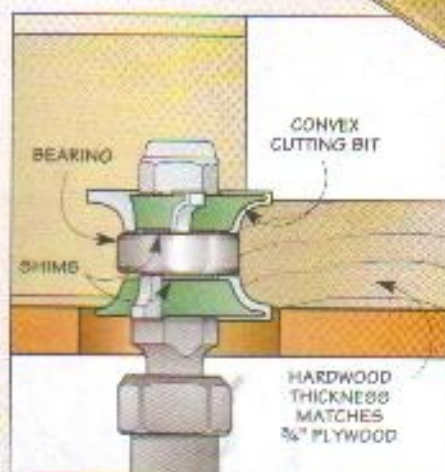

▲ **Convex Hardwood Bit.** Configure the bit with the same shim setup to assure an equal cut at the top and bottom surface of the hardwood edging.

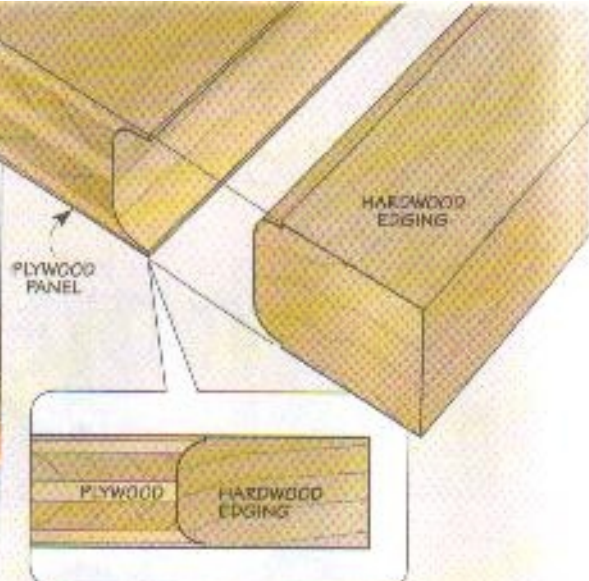

▲ **Edging Glueup.** The matching profiles makes it easy to center the wide edging perfectly every time during a glueup.

the bits to help you make sure the matching profiles line up correctly. There are also .048" shims to make it easier to work with materials like melamine and MDF.

The whole process is pretty simple. But to get the best result you'll need to spend a little time getting everything set up properly.

BIT SETUP

When you look at the bits, you'll see they come with bearings for handheld routing. But I like to use them with a router table and fence for a more controlled cut.

I also found it's necessary to begin by planing the hardwood used for the edging to the same thickness as the plywood. This way, you can set up both bits in the same manner to ensure the pieces will fit together perfectly.

Which Bit First? You can begin with either bit. But I find it easier to cut the concave profile on the plywood edge first. That's because the key to a good clean fit of the edging strip is to leave an equal, thin lip of veneer on the top and bottom faces of the plywood (left drawing above). This way, I'll be sure to leave the right amount of veneer on both faces.

Practice First. You'll want to make a few practice cuts so you

can "fine-tune" the bit height at the router table. Then you can rout the edge on the workpiece.

The next step is to cut the convex profile on the hardwood edging. Since you've just completed the setup up for the plywood edging profile, the setup for this bit is easy.

Convex Bit. To create a perfect hardwood profile match, you'll want to use the same configuration you used with the concave bit. This means if you added shims, you'll add the same number of shims when you set up this bit.

With the setup complete, you can use an extra-wide piece of hardwood to safely rout the convex profile (center drawing above).

The edging is now ready to be glued to the plywood, like you see in the far right drawing above. All you need to do is apply glue, slip the pieces together, and attach the clamps. There's no slipping and the edging matches perfectly.

Trim the Edge. Once the glue dries, you can decide how you want the edging to look. As shown in the drawing on the opposite page, altering the trimline gives the edging a different appearance.

You can trim it at the glue line for a solid appearance or leave a little extra to beef it up. You can even add a bullnose by using the bit shown in the box below. Any way you do it, you'll have a fine, finished look. 🐘



Adding a Bullnose

Adding a bullnose profile to 3/4"-thick material can be done in a single router pass with the *Burgess Edge Adjustable Bullnose* bit shown at left. The large bearing can be used on either the upper

or lower side of the cutters to allow you to use your router freehand. Just use the shims provided with the bit to set the cutters to match the plywood thickness. Then clamp a straight-edge on the glue line to guide the bearing, and you're ready to rout an edge like you see in the photo at right.

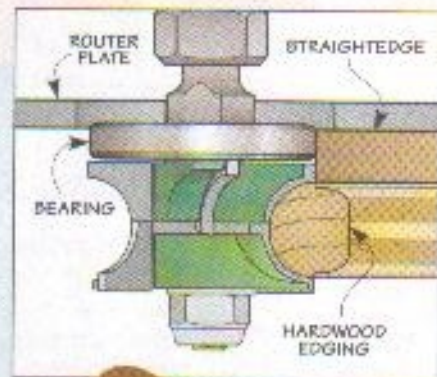

Shop Short Cuts



Routing a Hinge Mortise

When making the hinge mortises for the bench extension on page 16, the benchtop and the extension should fit tightly together with the top faces flush. So, it's important to locate and install the hinges in each piece correctly (inset photo).

After locating and marking the mortises on the benchtop (Figure 1), you can start removing the waste. I used a trim router with a clear plastic base because of its small size

and excellent visibility (main photo above). To provide stability for the router, it's a good idea to attach a support block while routing away the waste. The block also helps prevent chipout.

After routing away most of the waste, the next step is to clean up the edges with a chisel (Figure 2). The score marks you made to locate the mortises provide starting notches to guide the chisel.

Extension Mortise. To locate the mortises on the extension, pull out the supports, set the extension on them, and butt it up to the benchtop. Then, transfer the location from the benchtop to the extension (Figure 3). Now, you can make the matching mortises using the same techniques as before.

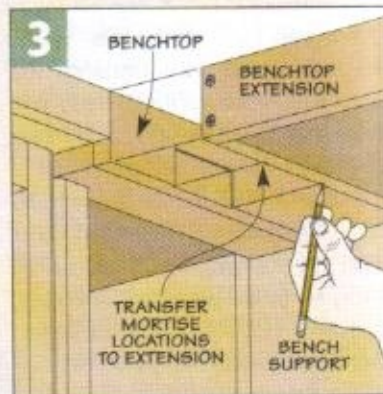
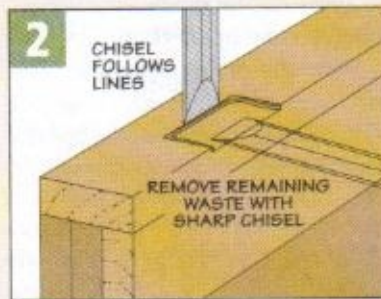
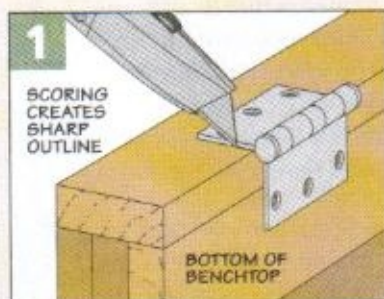

Accurate Dog Holes

The size and weight of the benchtop extension on page 16 makes it too unwieldy to drill bench dog holes with the drill press. So, I used my hand drill. To keep the hole spacing consistent, as well as to guide the drill bit square to the benchtop, I made a simple indexing jig, as shown in the drawing on the right.

A cleat registers the jig along the edge of the extension. A $\frac{3}{4}$ " dowel in one hole maintains the spacing while the next hole is drilled. And finally, rout a chamfer around each hole to soften the edges and prevent chipout when removing the bench dogs.

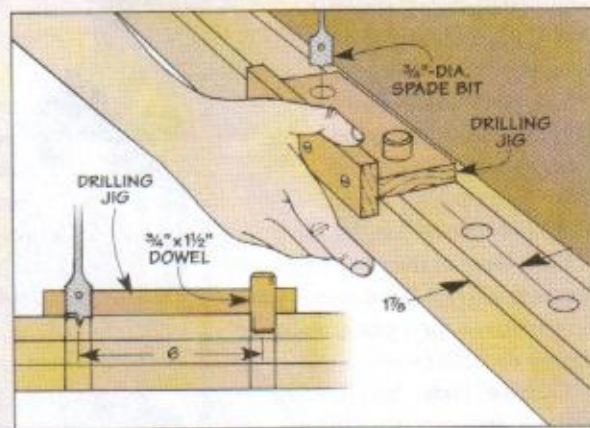

Cover Support Option

The blade cover on page 36 is designed to attach directly to a cast-iron wing or extension table for support. But the stamped steel wings on many table saws may flex. So, to provide adequate support, a different mounting configuration may be required. The photo on the right shows a good solution to that problem.

Installing a sturdy support beam between the fence rails is the first step. Detail 'b' shows how the support beam attaches to the rails for the table saw fence.

Now, you're ready to attach the support mast to the beam. The notch in the mast is sized to fit snugly over the beam (detail 'a'). It provides a solid, wiggle-free connection between the two parts.

Finally, extending a metal brace from the lower part of the mast to the underside of the table saw eliminates any flex in the lower part of the mast (inset drawing).

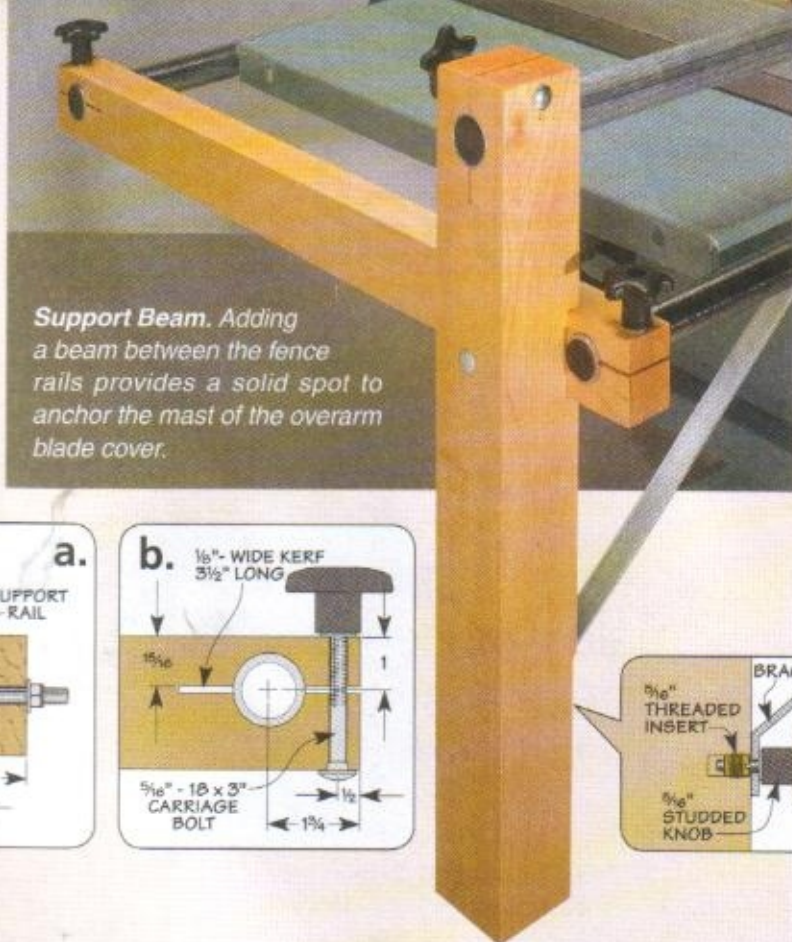

Support Beam. Adding a beam between the fence rails provides a solid spot to anchor the mast of the overarm blade cover.

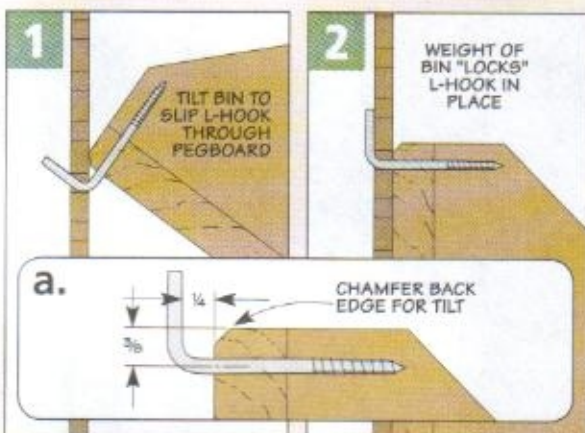
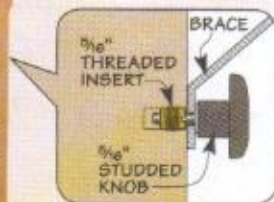
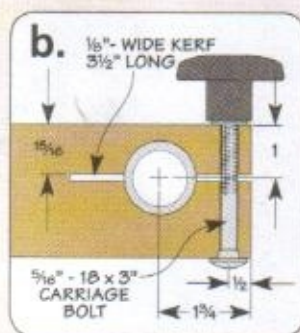
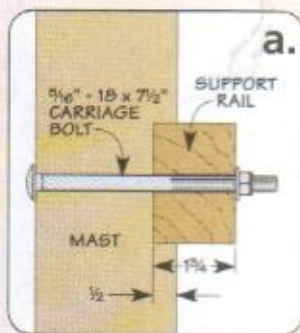

Bin Hangers

Bins that hang on pegboard are a good storage option for the one-wall workshop on page 16. And these bins are attached by using versatile L-hooks.

Detail 'a' shows how the L-hooks are installed in each bin. To hang the bin, tilt it so the L-hooks slip into the holes of the pegboard (Figure 1). Adding a chamfer helps with this. Then tip it down so the weight of the bin "locks" the L-hooks in place, as in Figure 2.

This makes it almost impossible for the bin to fall off of the pegboard, yet makes it easy to move it around as your storage needs change.

Bench Extension Modification

Adding a tail vise to the benchtop extension on page 16 can be a lot of work. If you'd rather not install the vise, you can gain more work area by making the extension longer. This is just a matter of filling in the space originally used for the vise.

Even without a vise, it's still a good idea to drill bench dog holes. You can drill the holes directly into the benchtop, using the indexing jig highlighted on the previous page. That allows you to use bench dogs and some other workbench accessories, like the *Veritas Wonder Pup*. The *Pup* is a clamping bench dog that acts like a small vise. (Refer to Sources on page 51).

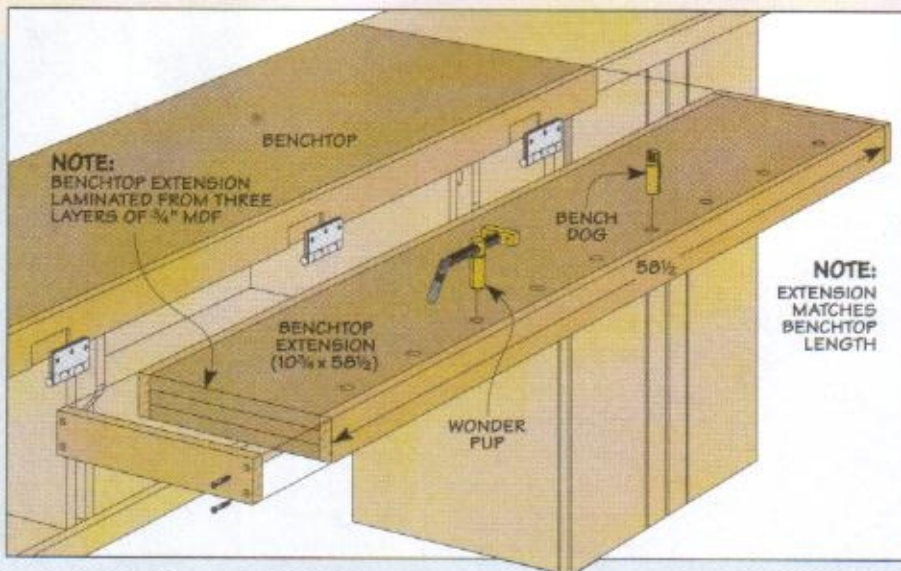

NOTE: BENCHTOP EXTENSION LAMINATED FROM THREE LAYERS OF 3/4\"/>

NOTE: EXTENSION MATCHES BENCHTOP LENGTH

storage solutions

one-wall Workshop

Turn a wall into the ultimate workcenter with these easy-to-build cabinet add-ons.

- The problem with most garage or basement shops is that they end up looking like the one you see in the inset photo on the opposite page. The challenges are finding enough storage, organization, and work-surfaces to work on projects.

One-Wall Workspace. That's where the "one-wall workshop" you see in the main photo really fills the bill. It starts with standard garage shop cabinets you can purchase online or pick up from a local dealer. This way, you can concentrate on organizing your shop and working on projects instead of spending time building basic storage cabinets and doors.

If you look closely, you'll see that I've "souped up" the cabinets with custom storage compartments, shelves, pegboard, and lighting.

Workbench. What I like best about this setup is the workbench. You can see in the photo this bench has everything you need for building projects, including vises and a row of bench dog holes. And when you're all done for the day, the front of the bench drops down out of the way like the leaf of a dining table.

So, by using manufactured cabinets and adding some custom features, you can turn a single wall into a great shop area.

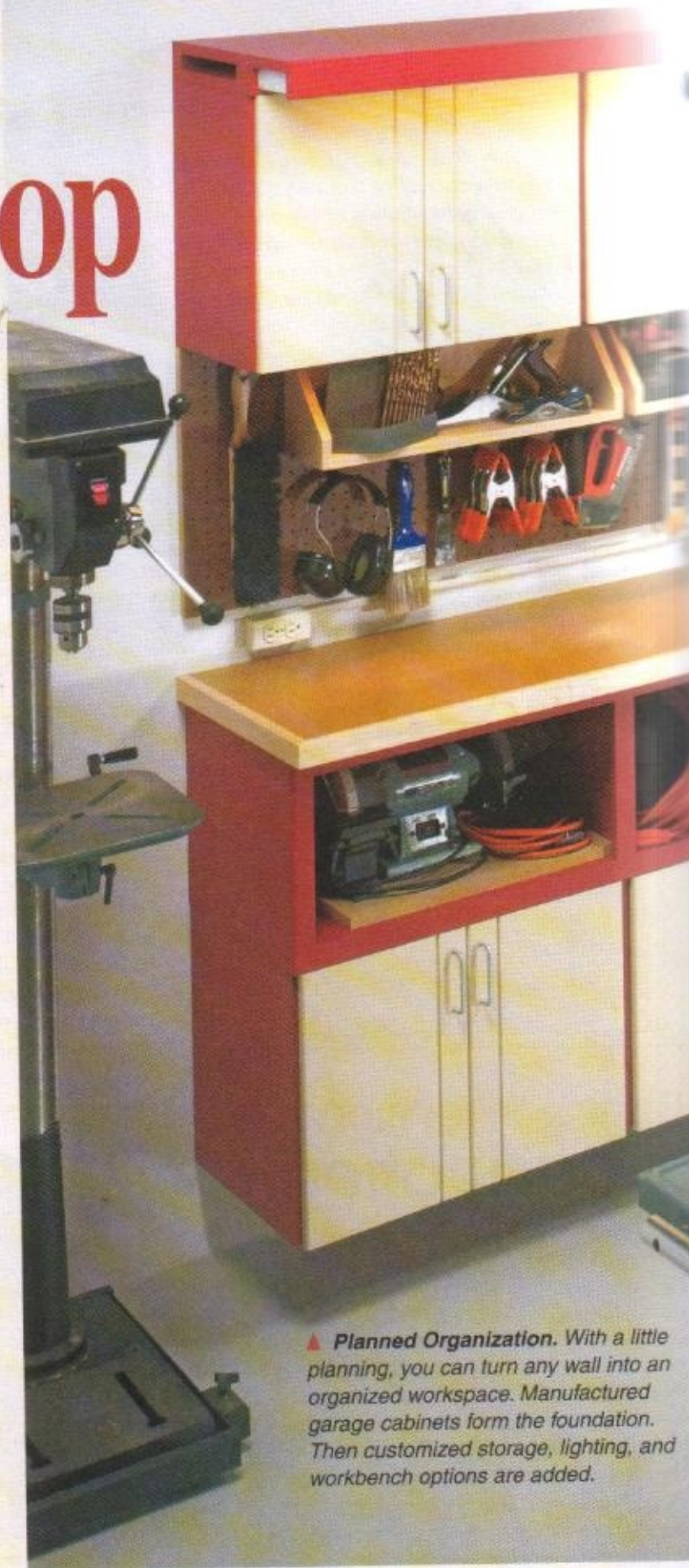

▲ **Planned Organization.** With a little planning, you can turn any wall into an organized workspace. Manufactured garage cabinets form the foundation. Then customized storage, lighting, and workbench options are added.

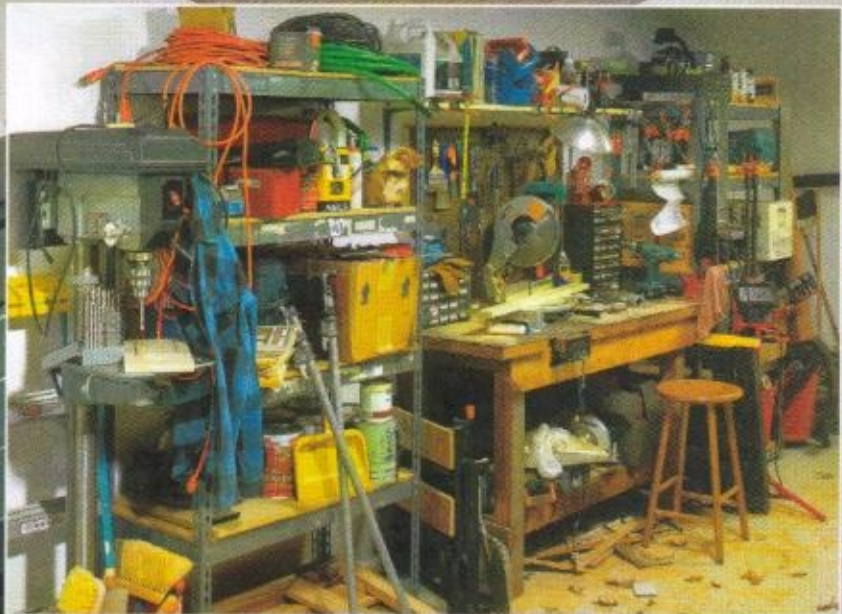

► **Chaos.** Shop organization is always a challenge and often takes a lower priority than the projects in the shop.

Exploded View Details

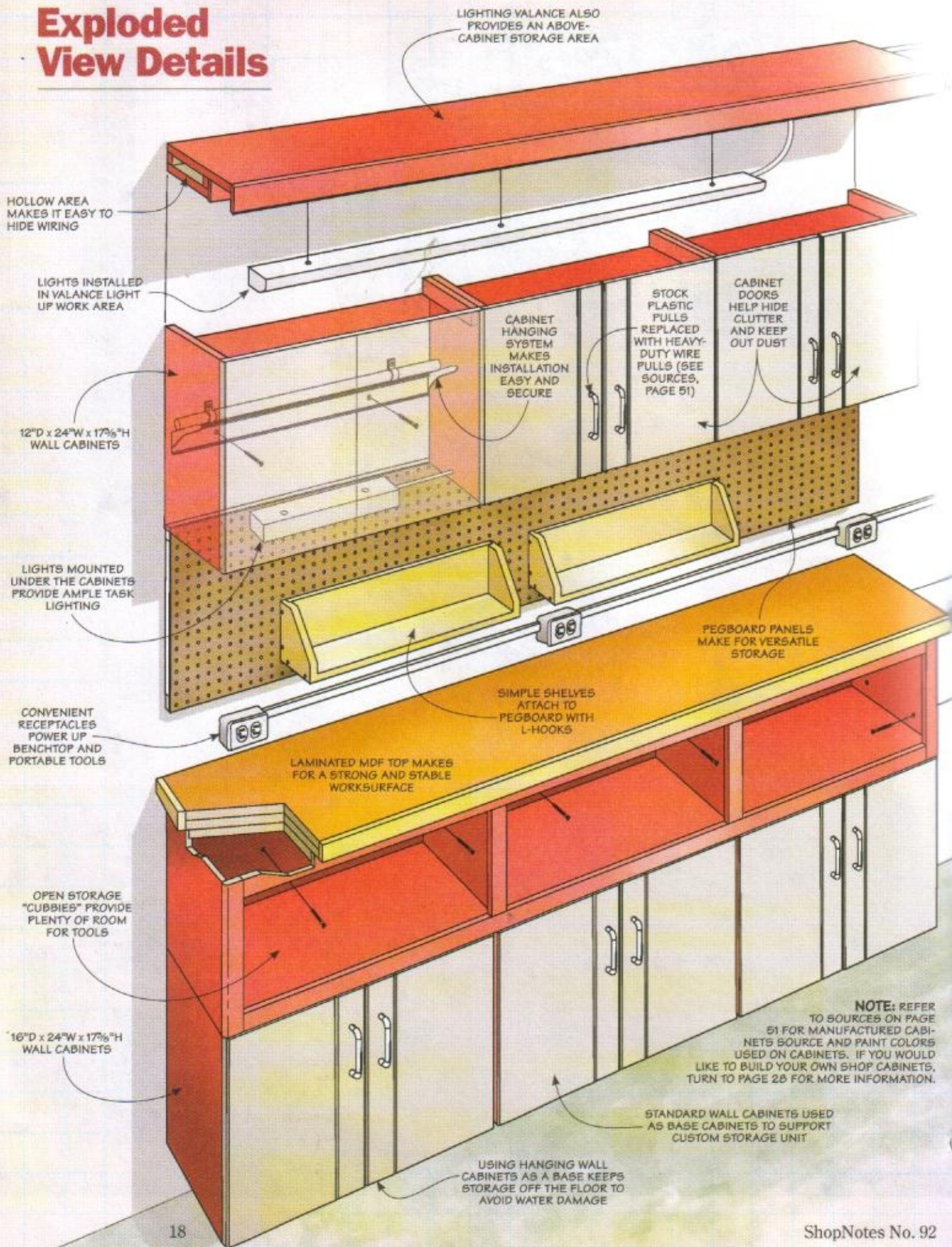

FIXED SHELVES PROVIDE STORAGE SPACE WITHIN EASY REACH

12"D x 24"W x 17 1/2"H WALL CABINET

24"D x 24"W x 72"H STORAGE CABINET

16"D x 24"W x 31"H WALL CABINET

BENCHTOP

TAIL VISE IS MADE USING A PRESS SCREW

FRONT VISE BOLTS TO BOTTOM OF FLIP-UP WORKBENCH

FLIP-UP WORKBENCH ADDS EXTRA WORKSPACE WHEN NEEDED

BENCH SUPPORT CABINET IS ANCHORED TO WALL AND ADJOINING CABINETS FOR MAXIMUM STRENGTH

PULL-OUT BENCH SUPPORT LOCKS BENCH IN WORKING POSITION

ShopNotes
GO ONLINE EXTRAS

Complete cutting diagrams for the One-Wall Workshop, are on our website ShopNotes.com

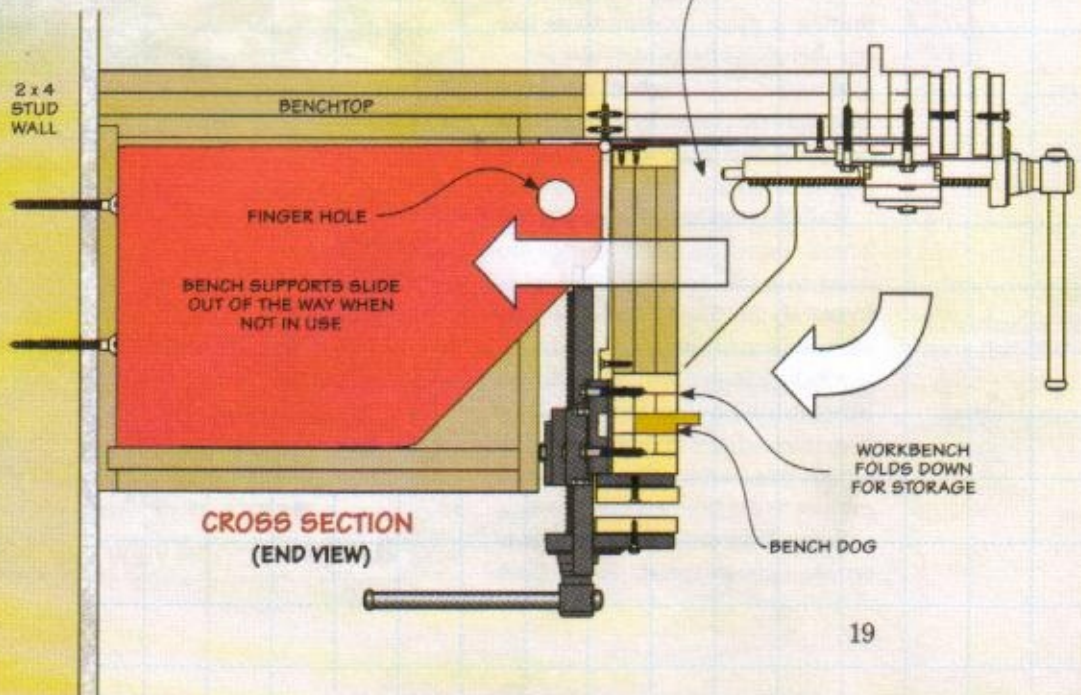

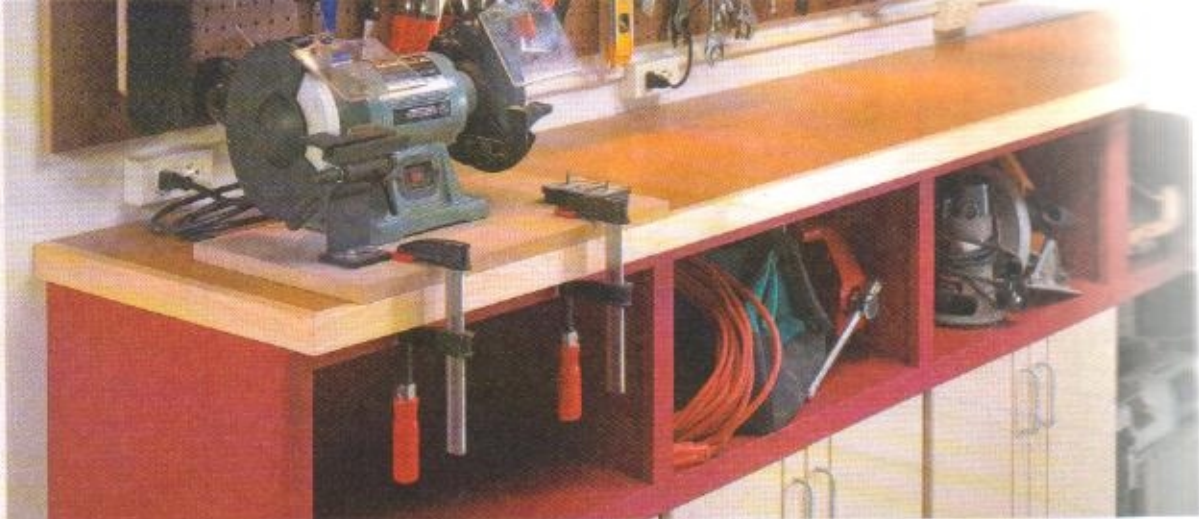

main workshop Section

To get started on your own one-wall workshop, you'll need to choose and install a set of wall cabinets like you see on pages 18 and 19. Then you can build the accessories to fit them. (You may have to modify a few dimensions to fit the cabinets you use.) The drawing in the left margin shows the heights I used for mounting my cabinets.

You can start with the lower section, as shown in the photo above. To save space in my shop, I used wall cabinets mounted as base cabinets. They aren't as deep as standard base cabinets. Plus, I mounted them off the floor to prevent damage from moisture and to make it easier to clean underneath them.

Open-Front Storage. The challenge with a small work area is finding a place to store tools like my bench grinder, circular saw, and router. That's where an open-front cabinet comes in handy. It fits on top of the three lower cabinets (photo above).

Building a Case. Figures 1 and 2 will show you everything you need to know to build the open-front cabinet. Dadoes and rabbets are used for all the joinery.

After gluing up the case, add the filler strips on the bottom. They give the screws a place to grab when you fasten the open-front cabinet to the cabinets below.

Face Frame. The face frame serves two purposes — it both

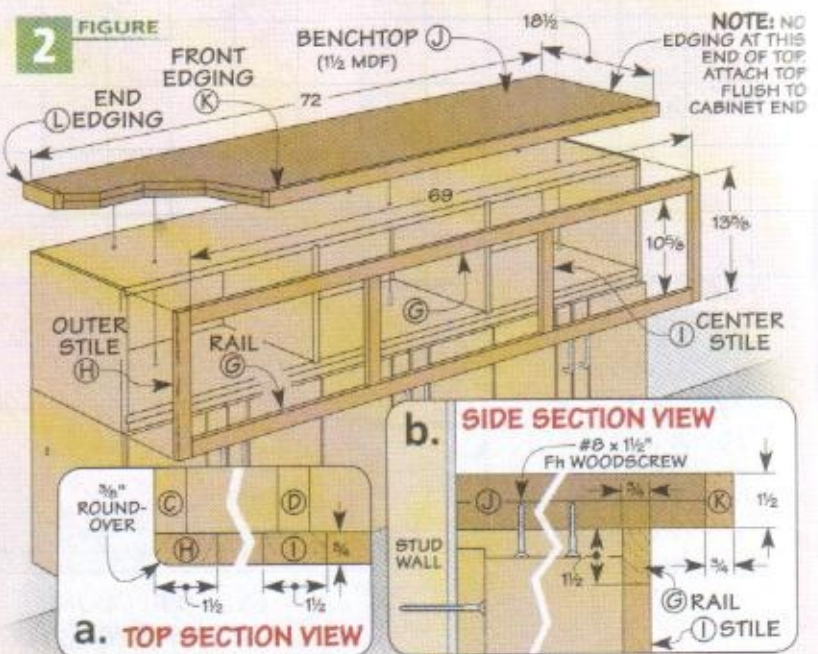
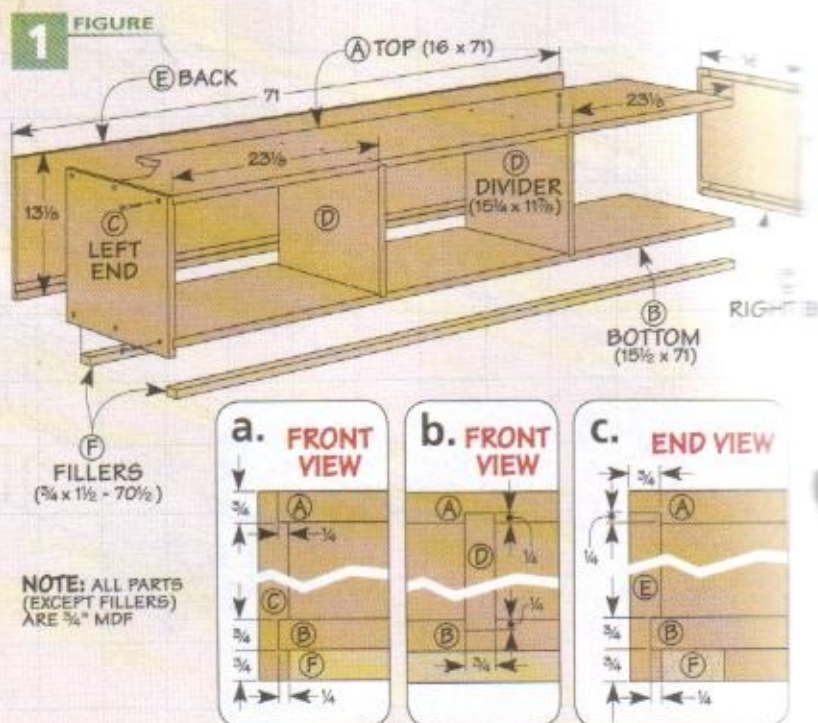
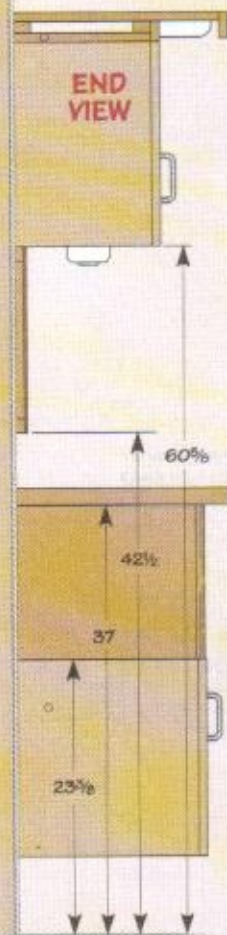



▲ **Overhead Lighting.** Lighting mounted in the valances light up the whole workspace.



▲ **Task Lighting.** Lights mounted under the upper wall cabinets are ideal for detailed tasks.

protects and hides the edges of the case. You can simply cut each of the pieces to fit and glue them in place, as in Figure 2. I rounded the outside edges of the two end stiles before attaching them to the case. After the face frame is complete, it's time to work on the benchtop.

Laminated Top. The top of the cabinet consists of two pieces of MDF that are glued together (Figure 2). This makes a solid and smooth work surface. Then it's just a matter of gluing hardwood edging on the front and left end. (The right end will butt up against the workbench section you'll build later.) Now you can fasten the top to the cabinets with screws (Figure 2b).

Before moving on to complete this section of the project, go ahead and install the three upper wall cabinets, as shown in Figure 3. You'll work on adding lighting and pegboard storage next.

Plenty of Light. One thing most shops never have enough of is adequate lighting. To solve this problem, a valance is added to the top of the upper wall cabinets to

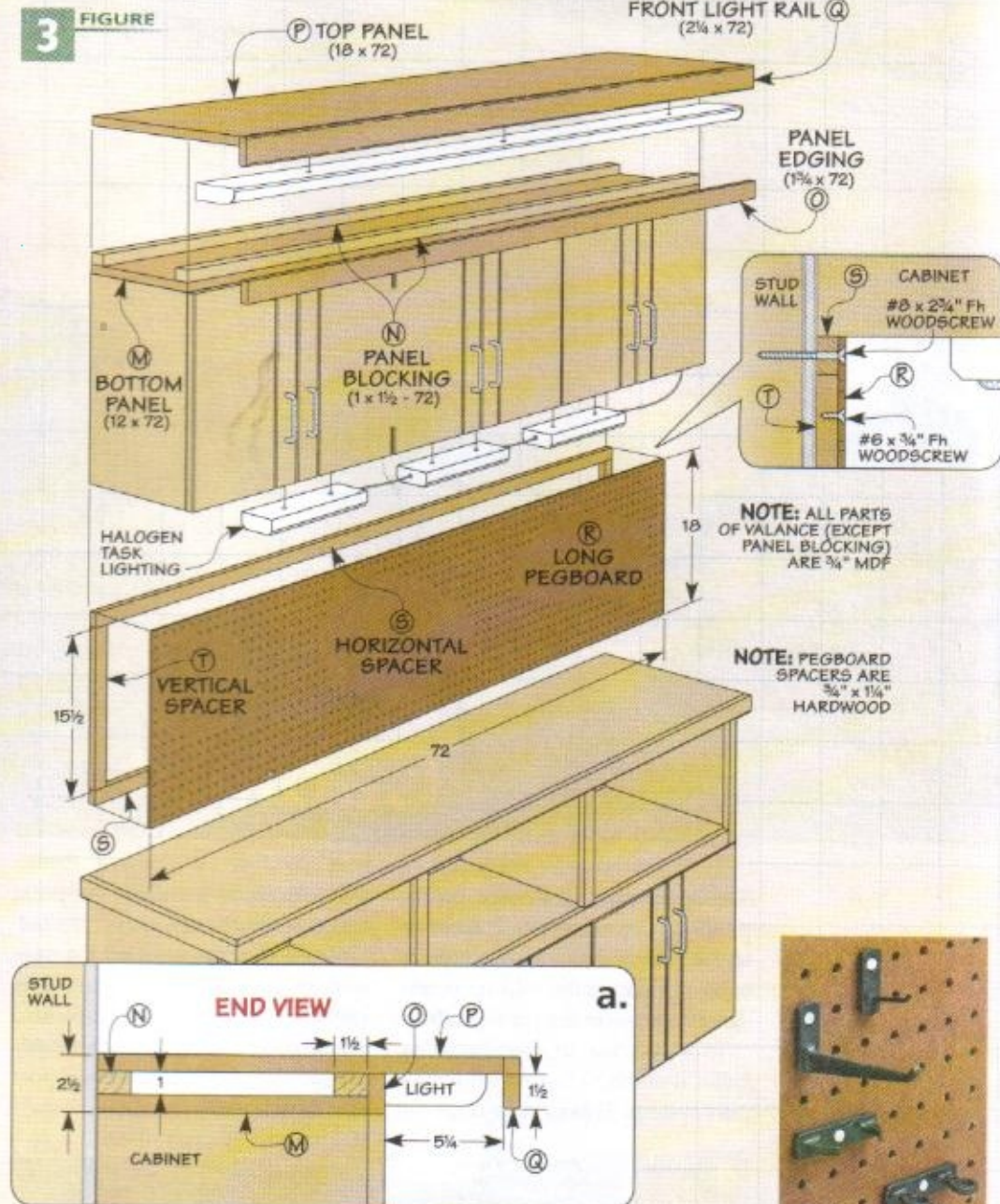

hold fluorescent fixtures (Figure 3). They cast a bright, broad light into the work area. Then for those close-up tasks on the workbench, under-cabinet lighting is just the ticket (photos above).

Building the Valance. If you look closely at Figure 3a, you'll see the valance is constructed like a hollow box. This creates a raceway for running the electrical wires for the fluorescent lighting.

I added the front rail before attaching the valance to the cabinets. Then it's just a matter of mounting the lights and making the electrical connections.

Under-Cabinet Lights. Small, halogen fixtures provide task lighting under the wall cabinets (Figure 3). You can wire them to a switch or plug them into receptacles above the workbench.

Pegboard Storage. An easily accessible pegboard tool rack completes this section of the project. I glued 3/4"-thick stock to the back of the pegboard before mounting it to the wall, as shown in Figure 3. They space the pegboard away from the wall to let hooks slip in place (margin photo).

Next, you'll work on the center section with the workbench.



▲ **Talon Hooks.** Regular pegboard hooks tend to move around and fall out easily. But Talon hooks stay put for secure storage.



► **Sliding Supports.** Sturdy bench brackets slide out to level the workbench and make for a stable worksurface.

workbench Cabinet

The benchtop and storage on the previous page is a great addition to any shop. But the centerpiece of this project is the fold-up workbench you see in the main photo.

To stand up to woodworking tasks, it needs to have a stout support system. This cabinet does the

job with its two pullout supports (inset photo above).

You'll start by building the case with its partitions. Then you'll add the sliding supports and top. And you'll need to install another cabinet on the right end to help support the bench cabinet. Later, you'll

build and install the fold-up workbench. But first, you need to build the bench cabinet.

Building the Case. If you look at Figure 4 below, you'll see the construction and joinery of the case for this cabinet is similar to the open front cabinet on page 20. The only difference is the addition and location of the vertical dividers for the sliding supports (Figure 4a).

After you assemble the case with glue and screws, just like you did before, you can build the two slide-out bench supports.

Sliding Supports. The bench supports are pretty simple, as shown in Figure 4. They're pieces of MDF cut to fit in the slots created by the partitions in the cabinet. A handy finger hole makes it easy to slide them in and out.

With the supports complete, you can finish out the case by adding the cabinet face frame next.

Face Frame. This face frame is a little different than the one on the storage cabinet you built earlier. There are only three pieces to make

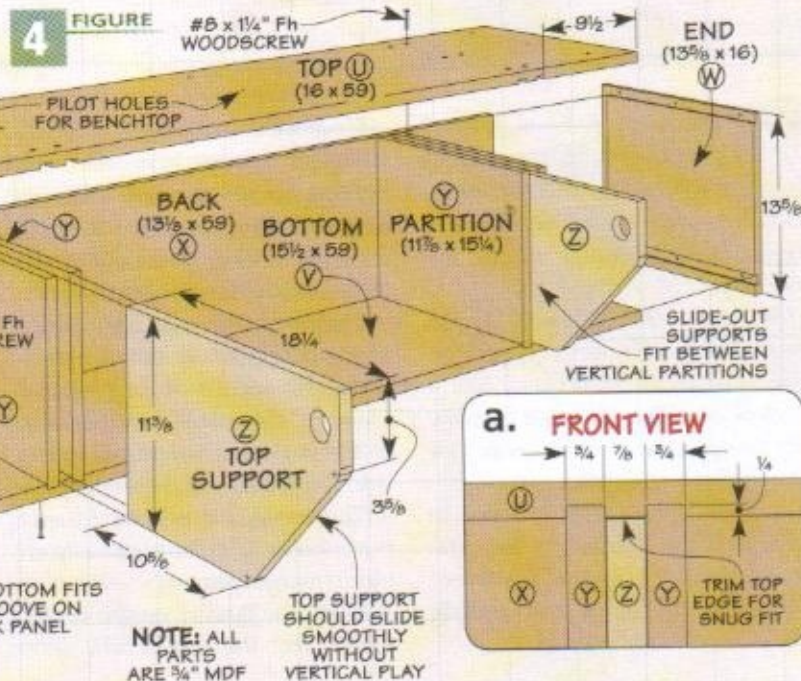
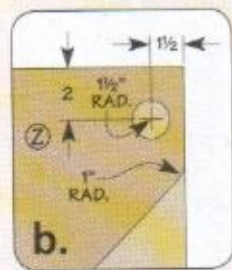

(Figure 5). I cut the two end pieces first. You'll need to cut these a little shorter than before to allow for a wide filler strip under the benchtop. Round over the outside edge of each before gluing them in place. Then it's just a matter of cutting the bottom piece to fit between them.

Benchtop. You make the benchtop from two pieces of MDF. But there's a filler strip that you'll need to add to the front (Figures 5 and 5a). This will help support the front rail where the folding bench section is attached with a set of hinges.

Front Rail. There's not much to attaching the front rail to the benchtop. It's simply glued to the front of the laminated MDF and filler strip. But MDF tends to soak up glue, so I first applied some glue to seal the edges of the MDF, waited a few minutes, then applied more glue before clamping the rail in place.

Attaching Hinges. You'll be working on the flip-up workbench section later, but now's a good time to cut the mortises for the hinges and attach the hinges to the front rail. To see how to make the mortises and get a nice, tight fit, turn to Shop Short Cuts on page 14.

Anchoring the Cabinet. There is a potential for a lot of weight and pounding on the bench, so you want to make sure the cabinet is anchored tight all around. In Figure 6 below, you'll see how the cabinet fits between the storage cabinet you built earlier and another manufactured cabinet. (Now is the time to mount the end cabinet, if you

5 FIGURE

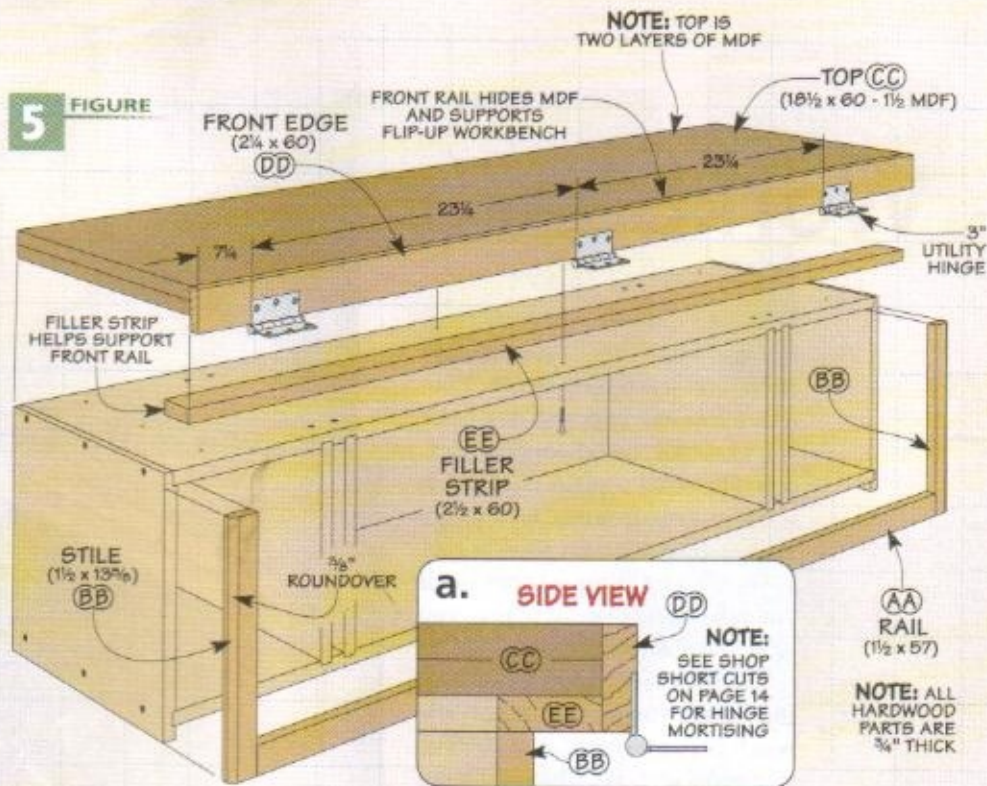

haven't already.) You'll want to be sure to leave room to fit the workbench cabinet snugly between the two end cabinets.

Go ahead and fasten the workbench cabinet to the two end cabinets with woodscrews. But for extra strength, I also screwed through the back of the cabinet and into the wall studs.

Small Top Section. Before working on the bench extension, there's one final piece to complete. It's the

top for the cabinet at the end of the bench. There's nothing new here — just two pieces of MDF and hardwood edging on the front (Figure 6a). A few screws are all you need to attach it to the cabinet.

With the bench support cabinet securely fastened in place, you're ready to work on the flip-up workbench. It's a handy addition that really makes this project stand out.

6 FIGURE

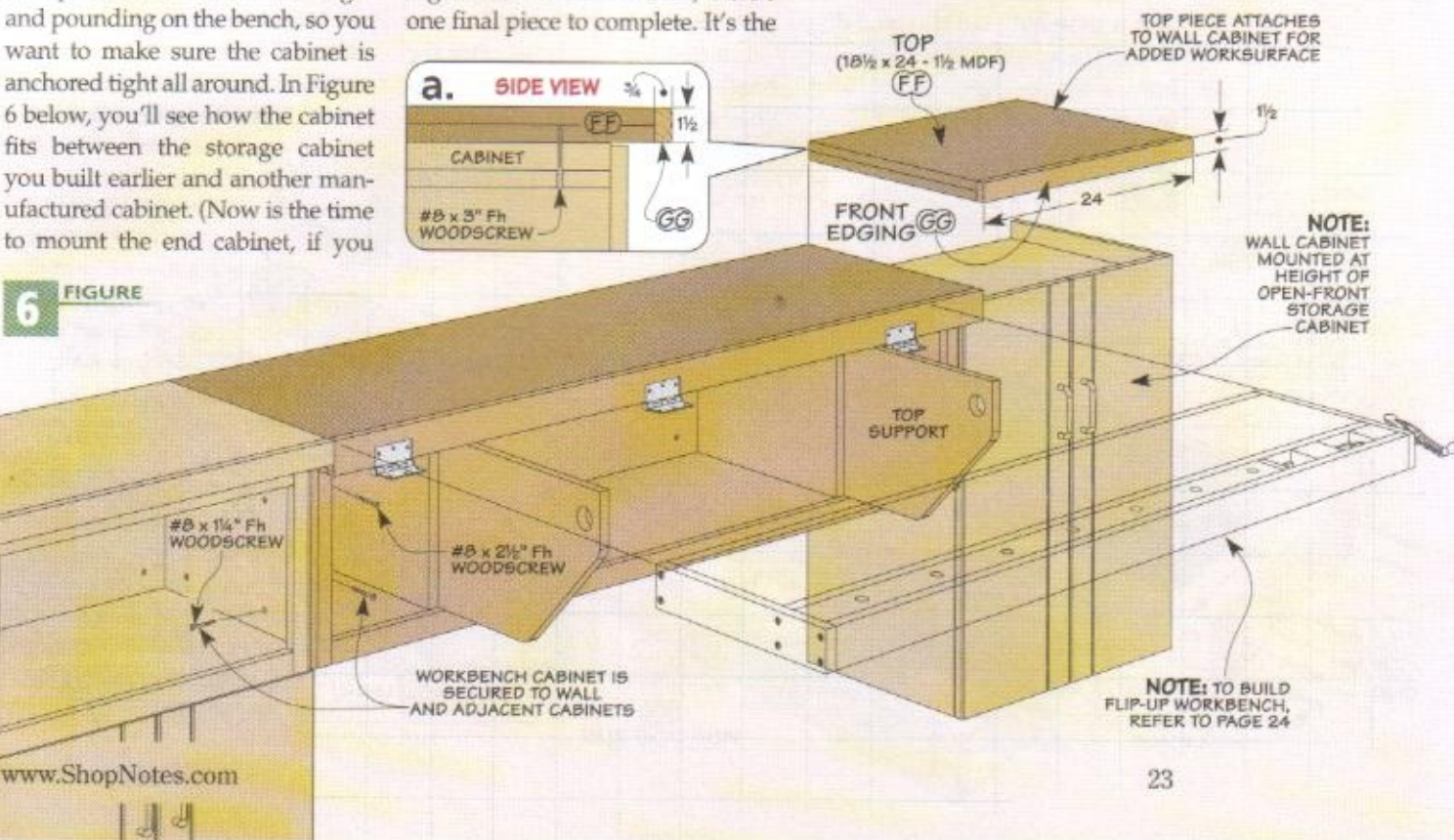

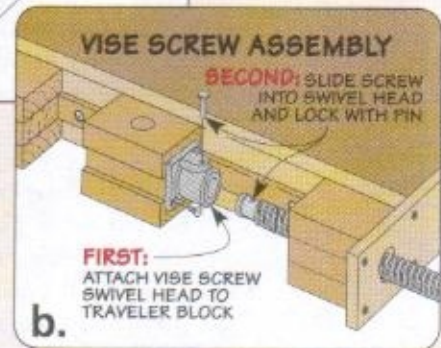
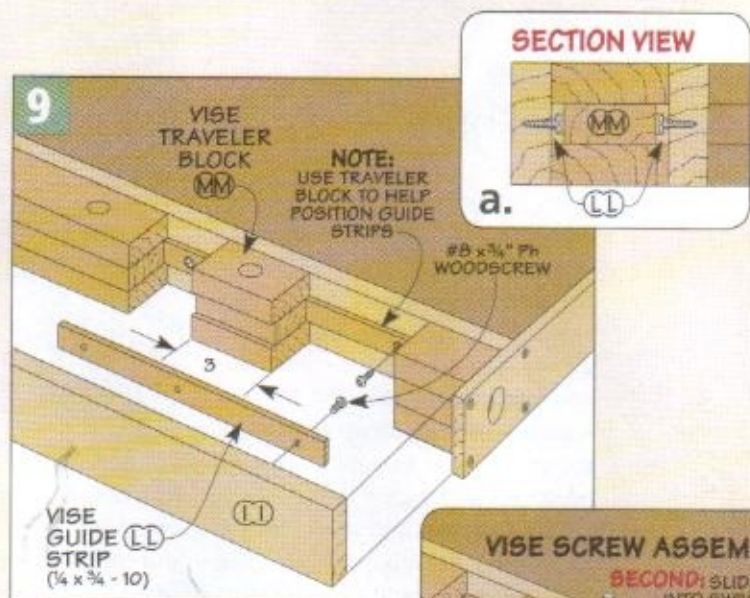
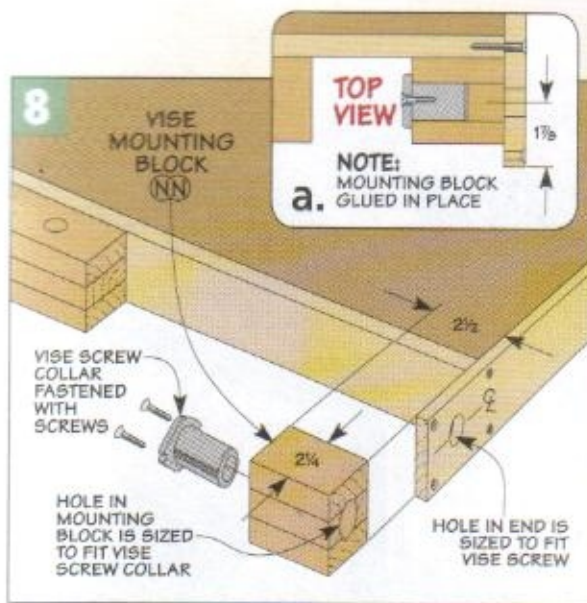

There's one more thing to do before gluing the block in place. And that's to make the end rail and drill it to accommodate the vise screw. To make sure the hole is located correctly, clamp the block in position on the bench and mark the hole location for the vise screw, as shown in Figure 8.

With the hole marked, drill the hole for the vise screw through the end rail and attach the end rail and mounting block to the benchtop.

Traveler. The other part of the tail vise to make is the traveler, as in Figure 9. Besides drilling a dog hole in the traveler, you'll also need to cut a groove on each side. The grooves ride over some guide strips as you operate the tail vise.

I cut the guide strips to fit the grooves in the traveler block. You're looking for a smooth, sliding fit that's not too loose.

Before screwing the guide strips in place, you need to make the front rail of the bench. For now simply clamp it in place to position the guide rails.

You can position the guides using the traveler block before fastening them with screws. You want the traveler block to be flush with the surface of the workbench at each end of the guide strips, as in the Section View of Figure 9.

Final Assembly. Now is the time to check the fit of the traveler block. Check to see that it

slides freely along the guide rails and sand the sides if the fit is too tight. Once you're happy with the fit, attach the vise screw (right margin). All that's left to do is glue the front rail and left end rail in place.

Face Vise. A face vise is a great addition to any workbench. The one I used simply bolts to the bottom of the bench. The only trick is to make sure it's positioned so that there's no interference when the workbench is folded down. A spacer aligns the top of the jaws flush with

the top surface of the bench.

Wedges. The last thing to do is attach support wedges to the underside of the flip-up workbench (bottom right margin). With the bench extended, slip the wedges between the extension and the slide-out supports. When the bench is level, fasten the wedges with screws to complete the workbench.

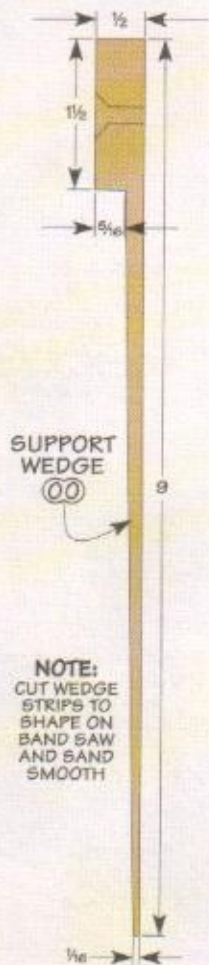
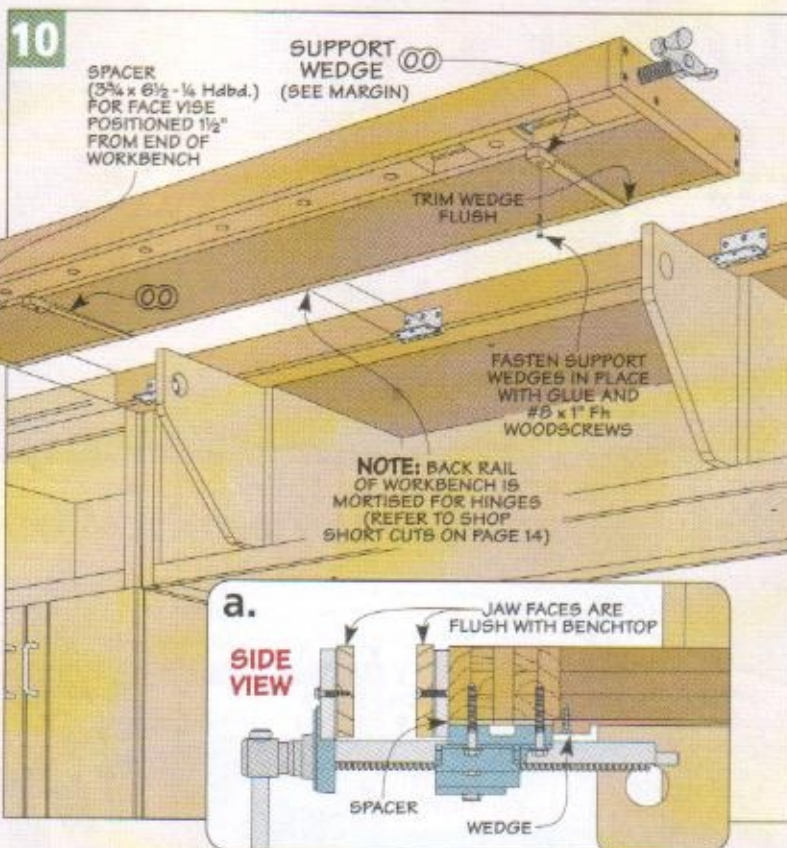

additional Storage

No matter how much storage you have, it doesn't take long to fill up the space. Here are some storage options you can add to your workspace. They range from a tall storage cabinet to small, portable pegboard shelves.

Tall Cabinet and Cap. To finish out the workshop, I added the tall cabinet and built a cap for it, as shown in Figure 11. A few screws secure the cap in place.

Valance and Pegboard. With the tall cabinet in place, you can add the final valance piece. You'll build it just like the one before, using the dimensions shown in Figure 11.

And you can complete the pegboard storage by building two more panels, as shown below. These will fill in the space between the panel you built earlier and the tall cabinet at the end of the workbench.

Permanent Shelving. At this point, all that's left to do is add

some additional shelving. I started with the fixed shelves shown in the photo above. They're a quick and easy solution for more storage space. Figures 11 and 12 show you how to put them together.

Once the edging is attached, use woodscrews to fasten the shelves at each end to the adjacent cabinets. (For added strength and to help prevent sagging, it wouldn't hurt to put a few screws through the back edging into the wall studs.)

Pegboard Shelving. If you look at the inset photo on the right, you'll see a handy storage option for the pegboard panels. The great thing is, they're adjustable.

Figure 13 below shows you everything you need to know to

build these functional shelves. See Shop Short Cuts on page 14 for some tips on building these shelves and adding the L-hooks. The L-hooks are used to hang the shelves on the pegboard.

Now, the fun part of organizing your shop begins. Once that's done, you can put the one-wall workshop to good use on all your future woodworking projects. 

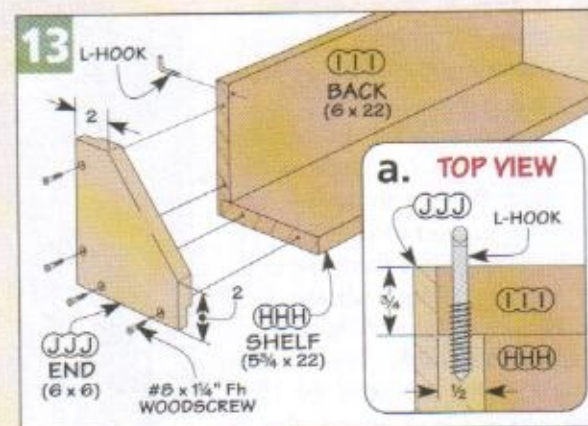
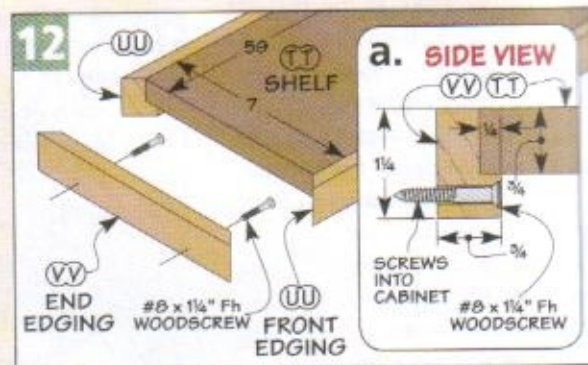
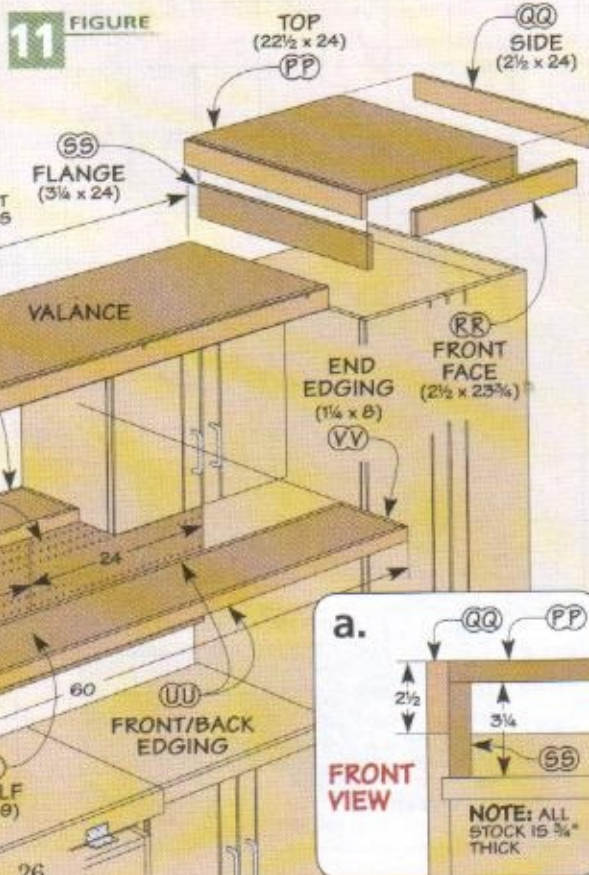
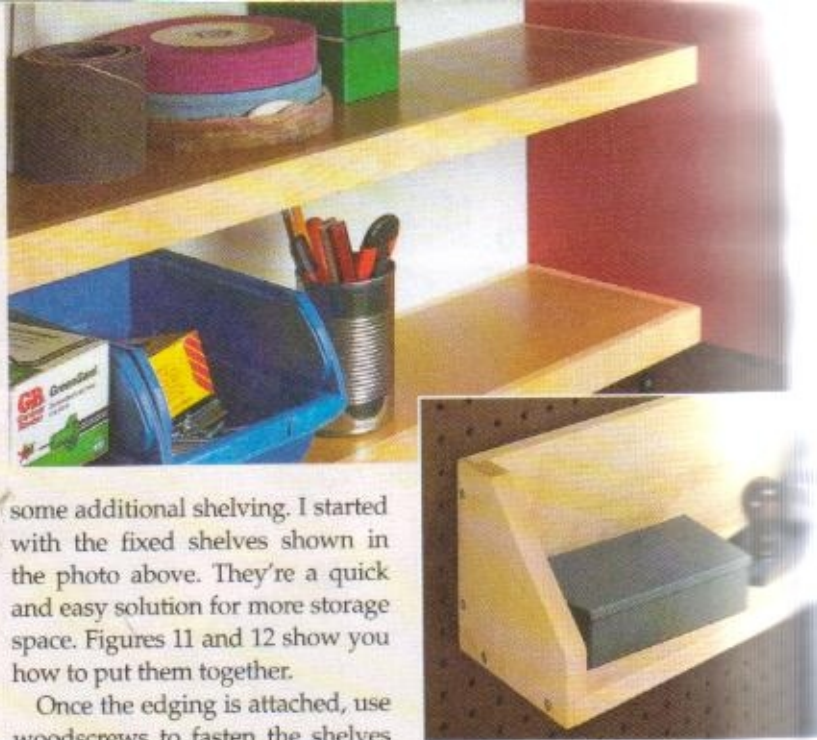

Floor Plan Options

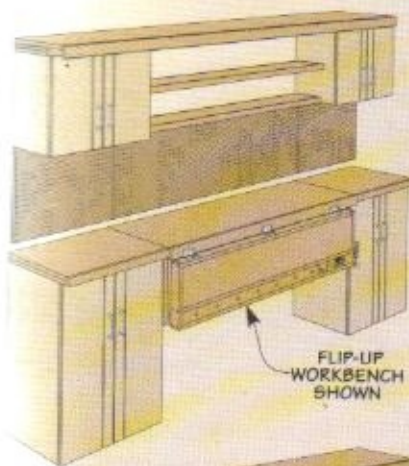

◀ **Simple Bench.**
Short on wall space? You can build a smaller version of the one-wall workshop, complete with a flip-up workbench.

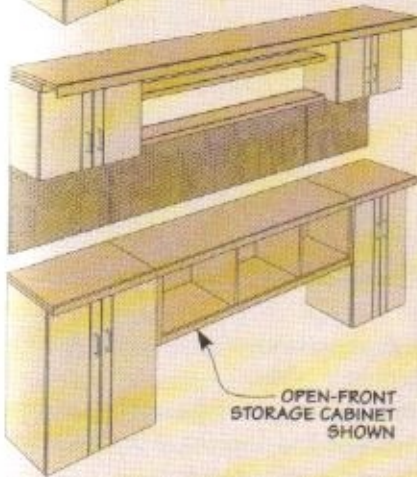

◀ **Storage Only.**
Front-loading "cubbies" add plenty of storage in a small area.

▶ **Corner Wrap.**
If your shop has the space, you can add corner pieces to wrap around and add more workspace.

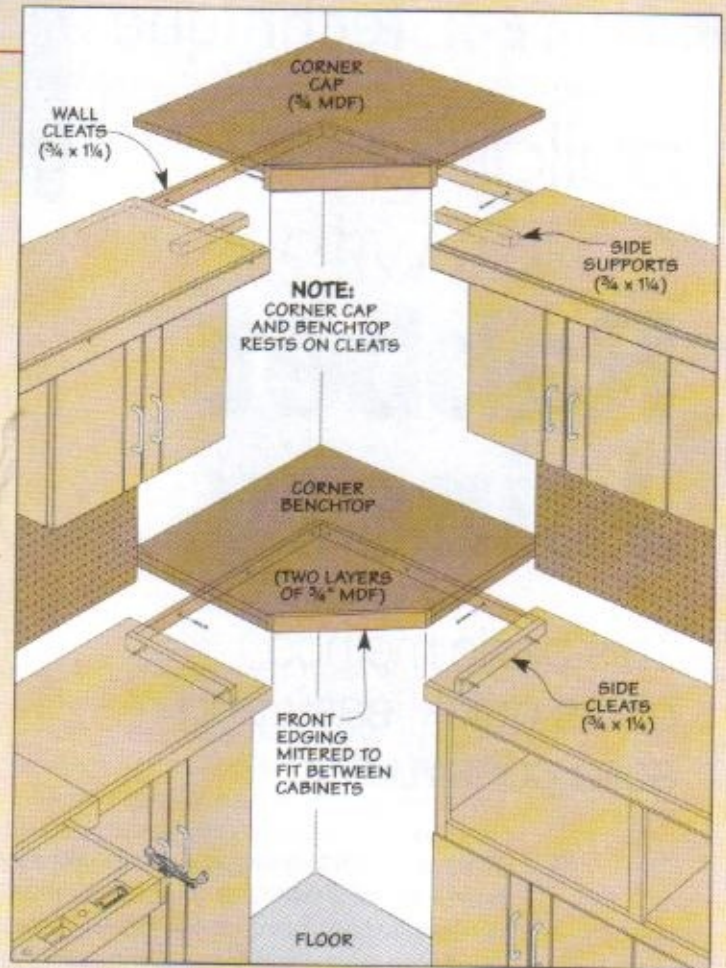

Materials & Hardware

STORAGE CABINET WORK AREA

A	Top	16 x 71 - 3/4 MDF
B	Bottom	15 1/2 x 71 - 3/4 MDF
C	Left/Right End (2)	13 5/8 x 16 - 3/4 MDF
D	Dividers (2)	11 7/8 x 15 1/4 - 3/4 MDF
E	Back	13 3/8 x 71 - 3/4 MDF
F	Bottom Fillers (2)	3/4 x 1 1/2 - 70 1/2
G	Face Frame Rails (2)	3/4 x 1 1/2 - 69
H	Face Frame Outer Stiles (2)	3/4 x 1 1/2 - 13 5/8
I	Face Frame Center Stiles (2)	3/4 x 1 1/2 - 10 5/8
J	Tops (2)	18 1/2 x 72 - 3/4 MDF
K	Front Edging	3/4 x 1 1/2 - 72 3/4
L	End Edging	3/4 x 1 1/2 - 19 1/4
M	Bottom Panel	12 x 72 - 3/4 MDF
N	Panel Blocking (2)	1 x 1 1/2 - 72
O	Panel Edging	1 1/4 x 72 - 3/4 MDF
P	Top Panel	18 x 72 - 3/4 MDF
Q	Front Light Rail	2 1/4 x 72 - 3/4 MDF
R	Pegboard	18 x 72 - 1/4 Pgbd.
S	Horizontal Spacer (2)	3/4 x 1 1/4 - 72
T	Vertical Spacers (2)	3/4 x 1 1/4 - 15 1/2

WORKBENCH AREA

U	Top	16 x 59 - 3/4 MDF
V	Bottom	15 1/2 x 59 - 3/4 MDF
W	Left/Right End (2)	13 5/8 x 16 - 3/4 MDF
X	Back	13 5/8 x 59 - 3/4 MDF
Y	Partitions (4)	11 7/8 x 15 1/4 - 3/4 MDF
Z	Top Supports (2)	11 7/8 x 18 1/4 - 3/4 MDF

AA	Face Frame Rail	3/4 x 1 1/2 - 57
BB	Face Frames Stiles (2)	3/4 x 1 1/2 - 13 5/8
CC	Tops (2)	18 1/2 x 60 - 3/4 MDF
DD	Front Edging	3/4 x 2 1/4 - 60
EE	Filler Strip	3/4 x 2 1/2 - 60
FF	Tops (2)	18 1/2 x 24 - 3/4 MDF
GG	Front Edging	3/4 x 1 1/2 - 24
HH	Top (3)	7 1/4 x 54 1/2 - 3/4 MDF
II	Rails (3)	3/4 x 2 1/4 - 54 1/2
JJ	Left/Right End (2)	3/4 x 2 1/4 - 12 1/4
KK	Visé Dog Run (3)	3/4 x 2 1/4 - 42
LL	Visé Guide Strips (2)	3/4 x 1/4 - 10
MM	Visé Traveler Block (3)	3/4 x 2 1/4 - 3
NN	Visé Mounting Block (3)	3/4 x 2 1/4 - 2 1/2
OO	Support Wedges (2)	3/4 x 1/2 - 9

ADDITIONAL STORAGE

PP	Top	22 1/2 x 24 - 3/4 MDF
QQ	Sides (2)	2 1/2 x 24 - 3/4 MDF
RR	Front Face	2 1/2 x 23 3/4 - 3/4 MDF
SS	Flange (2)	3 1/4 x 24 - 3/4 MDF
TT	Shelves (2)	7 x 59 - 3/4 MDF
UU	Front/Back Edging (4)	3/4 x 1 1/4 - 60
VV	End Edging (4)	3/4 x 1 1/4 - 8
WW	Bottom Panel	12 x 84 - 3/4 MDF
XX	Panel Blocking (2)	1 x 1 1/2 - 84
YY	Panel Edging	1 3/4 x 84 - 3/4 MDF
ZZ	Top Panel	18 x 84 - 3/4 MDF
AAA	Front Light Rail	2 1/4 x 84 - 3/4 MDF

BBB	Pegboard	18 x 24 - 1/4 Pgbd.
CCC	Top/Bottom Spacer (2)	3/4 x 1 1/4 - 24
DDD	End Spacers (2)	3/4 x 1 1/4 - 15 1/2
EEE	Pegboard	18 x 60 - 1/4 Pgbd.
FFF	Top/Bottom Spacer (2)	3/4 x 1 1/4 - 60
GGG	End Spacers (2)	3/4 x 1 1/4 - 15 1/2
HHH	Shelves (2)	3/4 x 5 1/4 - 22
III	Back Panels (2)	3/4 x 6 - 22
JJJ	Ends (4)	3/4 x 6 - 6

- (76) #8 x 1 1/4" Fh Woodscrews
- (42) #8 x 1 1/2" Fh Woodscrews
- (4) #8 x 3" Fh Woodscrews
- (2) #8 x 1" Fh Woodscrews
- (38) #6 x 3/4" Fh Woodscrews
- (6) #8 x 3/4" Panhead Screws
- (3) 3" Utility Hinges
- (1) Face Visé
- (1) Visé Screw
- (3) 48" Fluorescent Light Fixtures
- (7) Under-cabinet Halogen Light Fixtures
- (18) Wire Pulls
- (2) 1" L-hooks

MANUFACTURED CABINETS

- (3) 16"D x 24"W x 17 3/8"H Wall Cabinets
- (4) 12"D x 24"W x 17 3/8"H Wall Cabinets
- (1) 16"D x 24"W x 31"H Wall Cabinet
- (1) 24"D x 24"W x 72"H Storage Cabinet

building cases with Rabbet Joinery

This basic method offers quick, easy, and solid construction.



■ When it comes to building a sturdy case for a shop project out of plywood or MDF, basic rabbet joinery is often the best choice for the job. It's a fast way to assemble a cabinet without sacrificing strength.

Why Rabbets? Rabbet joinery has some very basic structural benefits. First, the shoulder and the bottom of the rabbet automatically capture and align the mating pieces during assembly. The result is that the parts go together easier. Second, the "two-sided" joint creates racking resistance and a much more solid case.

Finally, you have an abundance of good gluing surface — and more is definitely better.

Very Basic. Building a case with rabbet joinery couldn't be much easier. The drawing at the lower left illustrates how the pieces all go together.

To create a four-sided "box," all you need to do is cut rabbets across the ends of two opposite case pieces — most often the sides. The depth of the rabbet can vary from one quarter to three quarters of the thickness of the case piece. The width of the rabbet matches the thickness of the mating case piece so that the assembled joint forms a "flush" corner. A second series of rabbets along the back edges of the case pieces holds a back panel. This further stiffens the case and also allows you to easily attach it to a wall. Fasteners (screws work the best) and glue hold all the pieces together.

Considerations. Before getting to work, there are several things you'll want to think about. The first is how to size your case pieces. If the rabbets are cut on the case sides, the length of these pieces should match the height of the case (drawing at left). Then, to end up

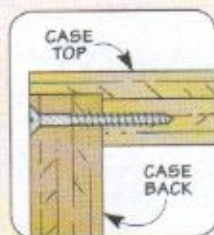

CASE ASSEMBLY

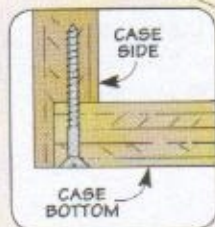
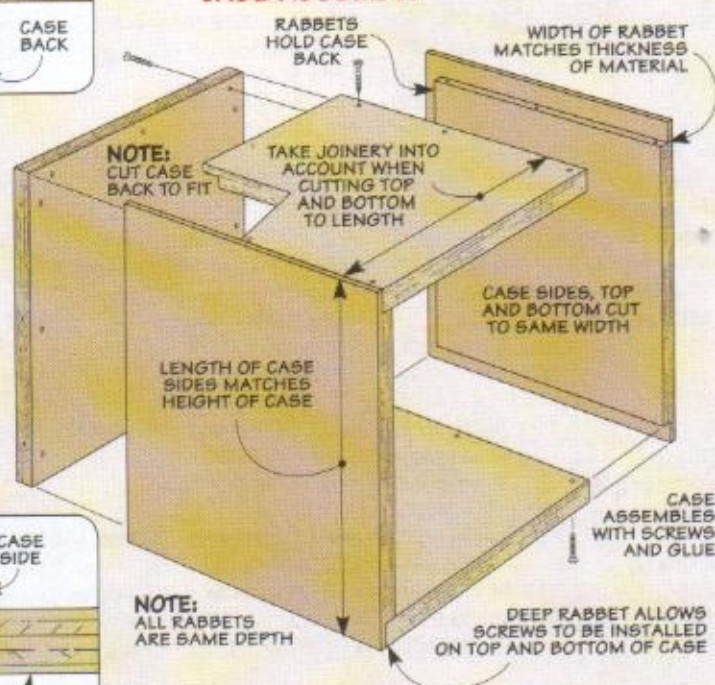

▲ **Two Good Options.** The left photo shows the simplest assembly option, a shallow rabbet with screws installed through the case sides. A deeper rabbet allows you to "hide" the screws (right photo).

with a case that's the correct width, you need to take into account the depth of the rabbets when cutting the top and bottom to length.

Assembly Options. This leads to the next point. The photos at the bottom of the opposite page show two rabbet/assembly options. The left photo illustrates the more basic assembly — a shallow rabbet with screws through the case sides pulling the pieces tightly together.

As you can see in the right photo, a deeper rabbet allows you to hide the screws on the top and bottom of the case when desired. Here, installing the screws takes a little more care, but you'll end up with a "cleaner" looking case.

Finally, there's one point to mention about the rabbets for the back panel. Their widths simply match the thickness of the back panel, while their depths match the rabbets in the case sides. This creates a "seamless" assembly.

A Setup How-To. Once you've done all the "advance planning" and cut your pieces to size, you can set up to cut the joinery. The drawing above shows the table saw setup I rely on to handle this job. It starts with a stack dado blade installed in the table saw. The blade should be wider than the width of the rabbets so you can make the cuts with a single pass. A zero-clearance insert surrounding the blade will help

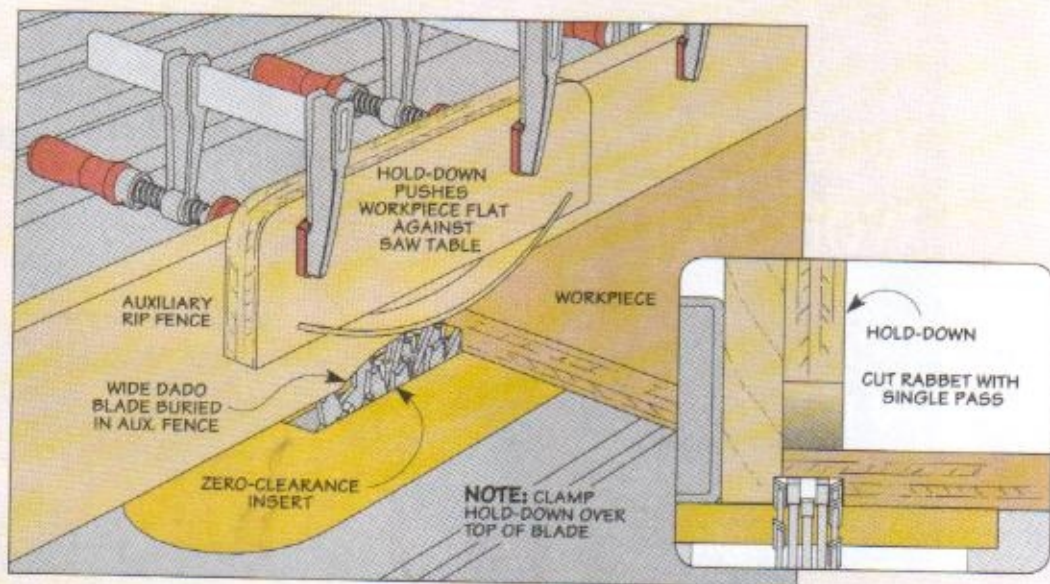

prevent chipping along the shoulders of the rabbets.

As you see, the edge of the blade is buried in an auxiliary rip fence. This is how you establish the width of the rabbets and guide the cuts. Finally, a hold-down clamped to the rip fence will ensure that the depth of the cuts is consistent.

Now, the Rabbets. With the table saw ready to go, the rabbets in the case sides come first. For accurate results, you'll need to carefully adjust the blade height and the position of the rip fence.

A separate test piece or one of your workpieces will help you with this. Start by adjusting the height of the dado blade until it cuts a rabbet of the correct depth. Then you can tweak the position of the rip fence to get the right width.

Now, you can simply make the cuts one after the other. Your goal is a consistent depth and width. The hold-down will help keep the workpiece flat against the table for a full-depth cut. So your main focus is simply keeping the workpiece snug against the fence.

The rabbets for the back panel follow. You may have to adjust the rip fence to match the width of the rabbet to the thickness of the back, but otherwise the setup is the same. All four pieces need a rabbet along the back edge.

That's it for the joinery. Now all that stands between you and a sturdy case is a tight, square assembly. You'll find a few pointers that will help you with this in the box below.

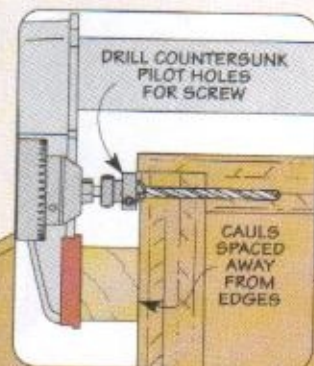

Rabbet Joinery: Assembly

Once the joinery is cut, the final task is to put all the pieces together into a solid case. The process is shown in the drawings at right.

Glue alone would work, but I like to reinforce the assembly with screws. So the first step is to dry assemble the case and drill pilot holes for the screws.

As you can see, clamps spanning all four sides are used to pull the joints tight. Cauls placed on the case top and bottom ensure that the

clamps pull these pieces snug up to the rabbet shoulders.

The cauls are placed back from the edges to allow access to drill countersunk pilot holes, as shown in the detail. A screw installed every 6" to 8" should do the job.

Now you can take the clamps off, add glue to the joints, reapply the clamps, and install the screws. And finally, the case can be flipped over to allow the back to be glued and screwed in place.

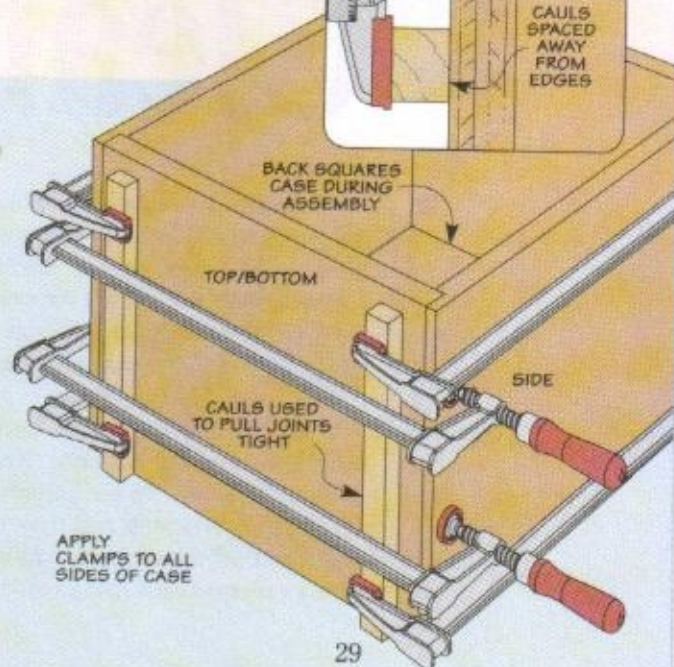

weekend workshop

Keep your cleaning supplies close at hand with this heavy-duty storage center.



shop-built Cleanup Center

■ I've built a lot of storage cabinets for my tools and hardware, so I always know right where to find them. Unfortunately, that wasn't the case for my cleaning supplies. To solve this problem I built the heavy-duty cleanup center you see above.

What's nice is the center has a number of handy features. First of all, it hangs on the wall, freeing up valuable benchtop and drawer space. Second, there's enough room to fit a variety of cans, spray bottles,

and other cleaning supplies. And, third, there are a couple of customized compartments for a box of shop rags and a roll of paper towels.

But the main reason I made this cabinet is to hold a roll of kraft paper. I like to use kraft paper to protect the top of my workbench from glue squeezeout and finish spills. When the paper gets dirty, I simply replace it.

Since it's more economical to buy the kraft paper in large rolls,

I added a hardwood roller and a shop-made paper cutter to the cabinet. Now, it's a snap to tear off any size sheet of paper I need.

Since the idea for the cleanup center is to provide a central location for shop cleaning supplies, I didn't need an elaborate cabinet. So, what you see here is a simple, no-nonsense plywood case with strong and sturdy dado joinery. And it all comes out of a single sheet of plywood.

Exploded View Details

OVERALL DIMENSIONS:
12 $\frac{1}{4}$ "D x 32"W x 35"H

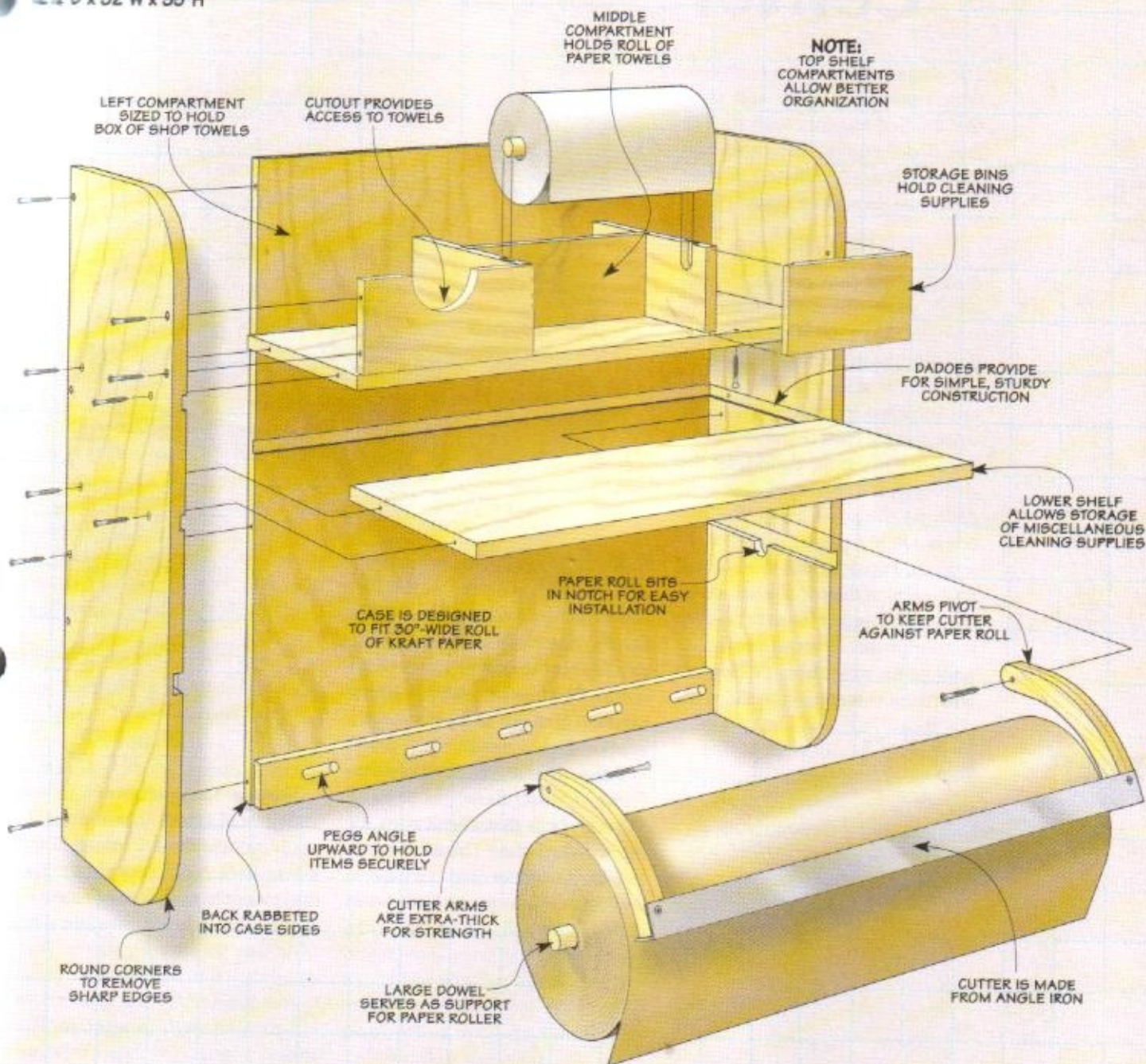

Materials & Hardware

CASE

A Back (1)	31 x 35 - $\frac{3}{4}$ Ply.
B Sides (2)	12 $\frac{1}{4}$ x 35 - $\frac{3}{4}$ Ply.
C Peg Rail (1)	2 $\frac{1}{2}$ x 30 $\frac{1}{2}$ - $\frac{3}{4}$ Ply.
D Pegs (5)	$\frac{1}{2}$ x 4 $\frac{1}{4}$
E Shelves (2)	11 $\frac{3}{4}$ x 31 - $\frac{3}{4}$ Ply.
F Left Face (1)	4 $\frac{3}{4}$ x 10 $\frac{1}{4}$ - $\frac{3}{4}$ Ply.
G Right Face (1)	4 $\frac{3}{4}$ x 8 $\frac{3}{4}$ - $\frac{3}{4}$ Ply.
H Side Dividers (2)	4 $\frac{3}{4}$ x 10 $\frac{3}{4}$ - $\frac{3}{4}$ Ply.
I Middle Divider (1)	4 $\frac{3}{4}$ x 12 - $\frac{3}{4}$ Ply.

J Paper Towel Bar (1)	1 x 12 $\frac{1}{2}$
K Cutter Arms (2)	1 $\frac{1}{2}$ x 8 $\frac{1}{2}$ - 1 $\frac{1}{2}$ Ply.
L Roller Bar (1)	1 x 31 $\frac{1}{2}$

- (1) 1 $\frac{1}{2}$ " x 1 $\frac{1}{2}$ " - 30 $\frac{1}{4}$ " Angle Iron
- (27) #8 x 1 $\frac{1}{2}$ " Fh Woodscrews
- (2) #8 x 1" Fh Woodscrews
- (2) #10 x 2" Fh Woodscrews
- (1) Roll of 30"-wide Kraft Paper

ShopNotes

GO ONLINE EXTRAS

To download a free cutting diagram for the Cleanup Center, go to:

ShopNotes.com

building the Center

The cleanup center is an open case with heavy-duty sides and back that are tied together with shelves and dado joinery. The cabinet is sized to fit a 30"-wide roll of kraft paper (see Sources on page 51).

THE CASE

Building the case out of $\frac{3}{4}$ " plywood gives the cabinet lots of strength. To make it sturdier, the back fits into rabbets cut in the back edges of the sides. Plus, the shelves are anchored in dados cut in the sides and the back (Figure 1).

After you cut the dados for the shelves, you'll need to make a third dado for the paper roller. But this one is a little different.

Kraft Paper Roller. Because of the weight of the roll of kraft paper, it's best to use a 1" wood dowel to support it and to act as a roller. To prevent the roller from pulling out when you're tearing off a sheet, the

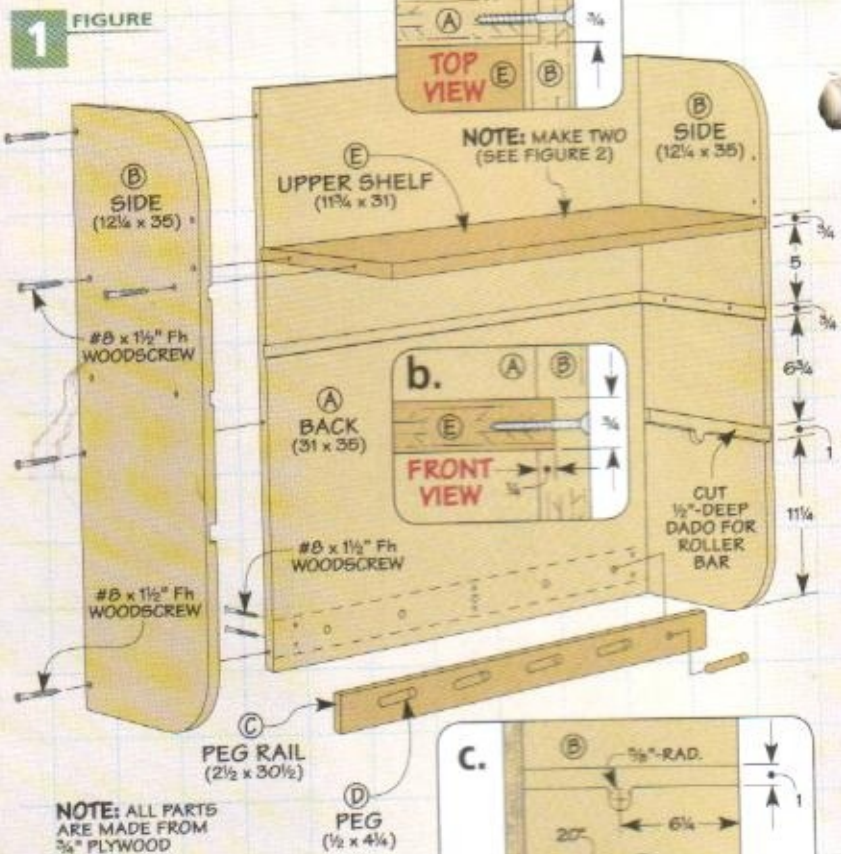

NOTE: ALL PARTS ARE MADE FROM $\frac{3}{4}$ " PLYWOOD

dowel rests in notches in the sides. So, the first step is to locate the notches for the dowel (Figure 1c). I used a Forstner bit and drilled the notches $\frac{1}{2}$ " deep to provide solid support for the roller.

Roller Dado. The next step, as Figure 1c also shows, is to cut a 1"-wide dado that aligns with the top of the notches. This allows you to slide the roller into the cabinet and drop it into place. Since most dado blades will not cut that wide, you may have to make two passes, sneaking up on the final width.

With the dados complete, you can cut the rabbets in the sides for the back (Figure 1a). Then, you can tackle the storage compartments.

Then, you can tackle the storage compartments.

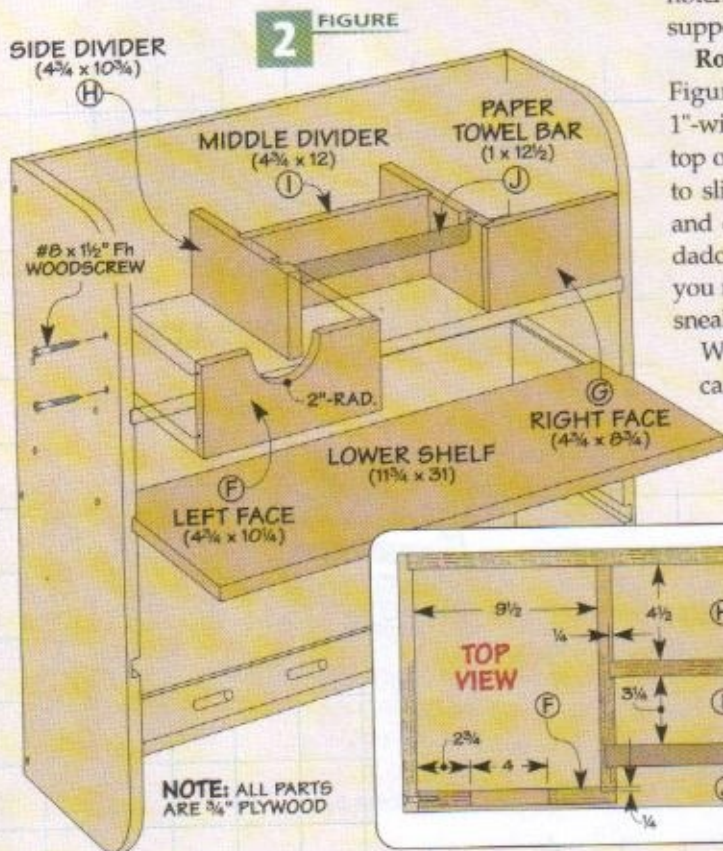
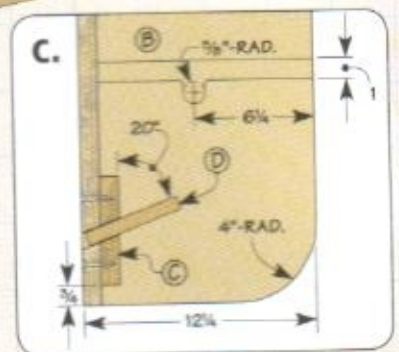

NOTE: ALL PARTS ARE $\frac{3}{4}$ " PLYWOOD

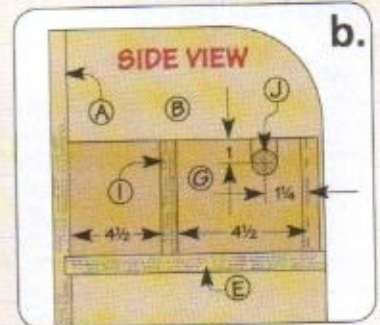
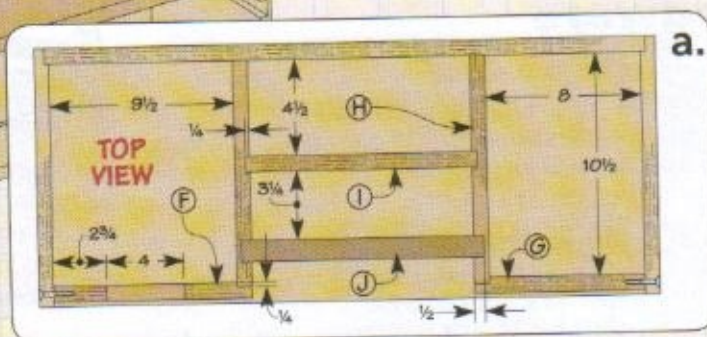

each compartment of the compartments are custom-sized to store specific items. In the first step is to size the left compartment to fit a box of sandpaper; shop rags, then you can use the middle compartment for paper towels.

Once the compartments are assembled on the top shelf, you can adjust the size of the right face to complete the last compartment. Finally, you can glue and screw the lower shelf into place.

Peg Rail. Next, I turned my attention to the peg rail. To keep items on the pegs, they're set at a 20° angle (Figure 1c). I made the rail using my drill press with a Forstner bit and tilting the table.

To give the pegs more strength, they're supported by the back of the case. To do this, first attach the rail to the back. Then, using the holes in the rail as a guide, drill through the back with the same Forstner bit and at the same angle. Glue will hold the pegs firmly in the holes.

THE PAPER CUTTER

The final step is to make and add the paper cutter. It consists of an angle iron attached to pivoting arms. This keeps it sitting firmly against the roll for easier ripping.

Arms. Each pivoting arm is made from two pieces of $\frac{3}{4}$ " plywood glued together, as Figure 3 shows. The double-thickness of the

3 FIGURE

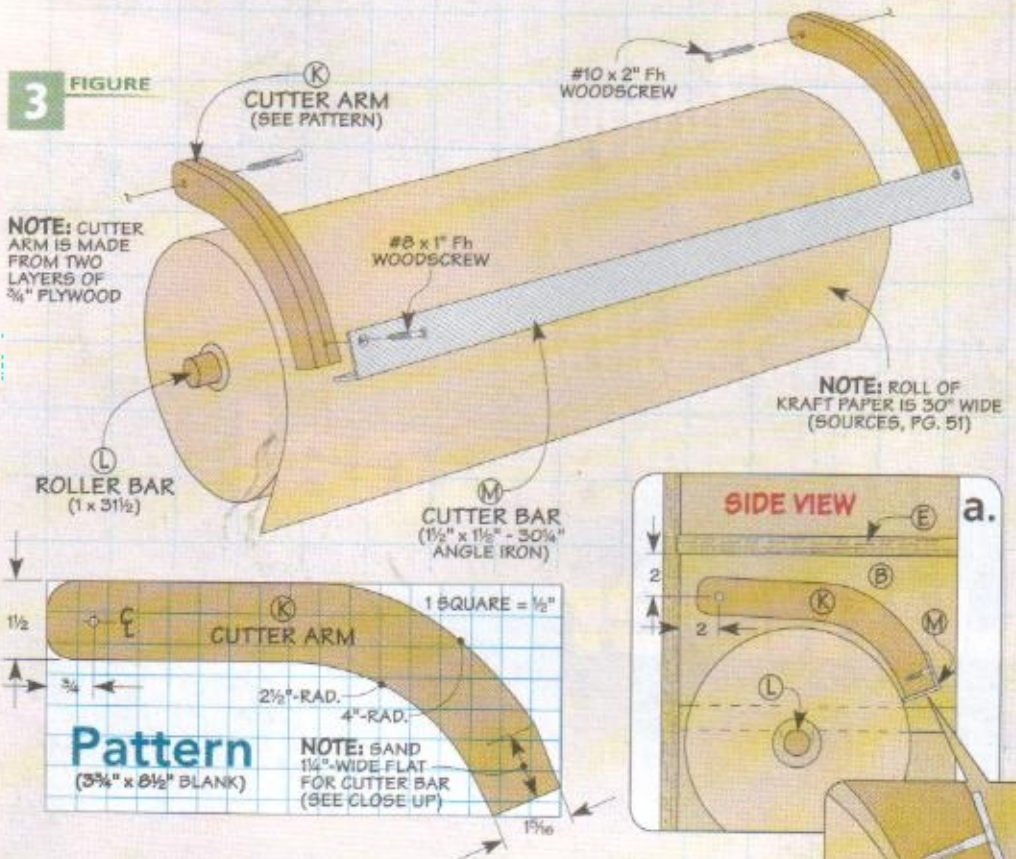

arms will prevent the cutter from twisting as you rip the paper off the roll. When the glue dries, you can use the pattern drawing above and your band saw to cut the arms to their final size and shape.

The next step is to install the arms (Figure 3a). But don't tighten them down completely — they need to swing easily when you replace the roll and as the roll gets smaller.

Angle Iron. With the arms in place, you can cut the angle iron to length that serves as the paper

cutter. After filing the ends smooth, go ahead and attach it to the arms.

Wall Installation. With the cutter installed, the cleanup station is ready to be hung on your shop wall. Remember, the cabinet itself is heavy and will be that much heavier once you slip the roll of kraft paper on it, so make sure you hang it securely.

Now, all that's left to do is chase down the cleaning supplies in your shop and corral them into your new cleanup station.



◀ Roller Setup.

The paper roller slides into wide dados and rests in notches. The angle iron provides a straight edge for ripping off sheets of paper.

◀ **Easy Rip.** The pivoting arms of the paper cutter allow the angle to rest against the paper roll. This makes it easy to tear off just the amount of paper you need.

HANDS-ON Technique

working with Dimensional Lumber

With a little planning and work, you can build great-looking, low-cost projects.



▼ **Lay Out the Parts.** To make the best use of material, mark and cut out the pieces before jointing and planing.

It would be great to have a shop full of hardwood storage cabinets and benchtops. But let's face it, using expensive hardwood lumber for every shop project is a luxury few of us can afford. Fortunately, you don't have to break the bank to build durable and attractive cabinets, worksurfaces, or benches.

The solution is as near as the local lumberyard — low-cost, “two-by” lumber. You're probably

already familiar with some of the downsides of dimensional lumber. It comes from a variety of species of pine, fir, or spruce and is often in pretty rough condition. In fact, warped, checked, twisted, and very wet lumber is common. So, it takes a bit more work to get the most out of this material. But with a little extra planning and patience you can get great results.

Selection. Building a successful project with ordinary lumber begins by choosing the right boards. When I shop for dimensional lumber, the first thing I look at is the moisture content. And most of the time I don't need a moisture meter to see how wet some of this lumber can be. These boards are often wet to the touch. That doesn't mean you should avoid these boards. All you need to do when you get them back to your shop is stack them with stickers (small pieces of wood) in

Still Wet? Allow the lumber to dry by stacking the boards on wood stickers for better air circulation.

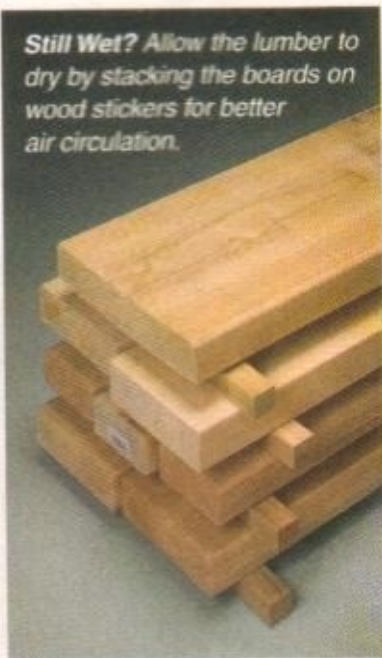

a place with good air circulation, as shown in the photo above, and allow them to dry. Depending on conditions, they'll be dry enough to work in a few weeks.

Straight Stock. Even if you can't find dry lumber, chances are you'll still want to pick through it carefully to find the best boards. The big thing I try to avoid is wasted stock. You can usually work around slightly bowed or cupped boards, but correcting them just takes too much effort. And since you'll most likely have a large selection to choose from, leave the bowed stock at the store.

Grain. Once I've sorted out the straighter pieces, I start to look at the grain. For most shop projects, this isn't a big concern, but if I'm going to use the lumber for cabinet doors, trim, or any other application that calls for a visual appeal, I take the time to find the straight or quarter-sawn grain I'll need.

Depending on the project, you can also come up with a strategy for rotating the stock and getting a quartersawn look. The box below gives you an idea of how to do this. In addition to being nicer looking, this will make for more stable, longer-lasting panels as well.

Cutting, Jointing, and Planing. The next step is getting the boards cut to size, squared-up, and planed to thickness. Overall, the process is pretty similar to working with rough-cut hardwood stock.

Here I like to begin by inspecting each board (again) for warping, bowing, and checking. At this

point, you can lay them on the bench and start roughing out the parts you need in chalk directly on the boards, as in the lower left photo on the opposite page.

This is a good time to identify the knots or other defects you'll have to work around. I reserve the best boards for the longer pieces of my project. This way, you can compensate for bowed or warped boards by cutting them into shorter pieces and eliminating any problems.

Once the parts are cut to rough size, you can move on to the jointer to square up one edge and one face. The difference here is that you'll also need to get rid of the rounded edges typical on dimensional lumber. Then, you can plane the opposite face and trim the opposite edge at the table saw. As you can see in the photo at right, you'll lose a little more thickness and width in this process than you would with hardwood lumber, so make sure to take that into account in your plan.

Joinery. Now that you have your boards flat and square, it's time to cut out the parts for your project and work on the joinery. The thing to remember here is that you don't want to get too fancy with "two-by" stock. Softwood won't hold an edge the way oak or maple will. But that doesn't mean you can't make a mortise and tenon joint or rout a simple edge profile.

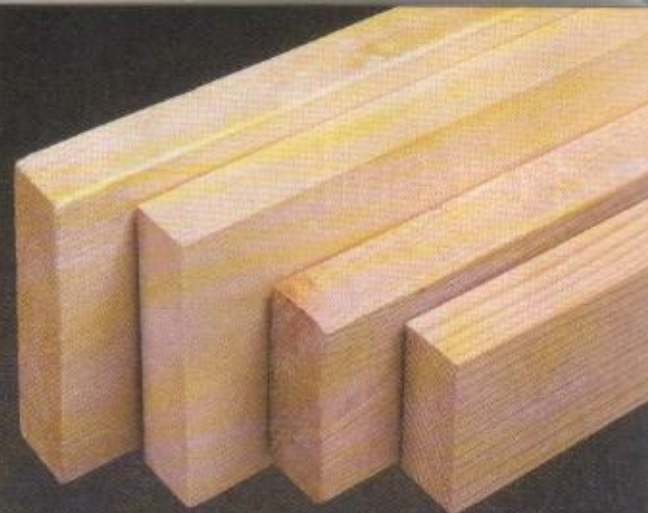

Jointed and Planed. Your stock will end up a little narrower and thinner after flattening and squaring, so plan for the reduced dimensions.

Sanding. You're probably already familiar with the tendency of "two-by" lumber to splinter at the cutline. So after I cut out the parts, I plan on doing a fair amount of sanding. But sanding softwood goes pretty fast. You can move through the grits and get a smooth surface quickly using either a random-orbit sander or a sanding block.

The "Two-by" Solution. By now you can see that dimensional lumber can be used as a great, low-cost material for your shop projects. It's durable, easy to work with, and if you're willing to take a little extra time and use your creative talents, it can be as attractive as hardwood. And since it's available just about anywhere, there's no good reason to put off building any of those shop projects any longer. 

Create Your Own: Straight-Grain Panels

One of the best ways to make "two-by" stock more attractive is to make a series of cuts at the table saw exposing the straighter grain, as in the photo at right. You can start by marking the boards in a way that will yield the straight-grained face. Then, it's just a matter of ripping the stock on the table saw, rotating it to expose the best edge, and gluing it back together with the straight grain surfaces facing up.

This is a great way to make table tops that are both more stable and better-looking. And using this method allows you to determine the thickness of the top just by adjusting the width of the cuts. So you can even make a top thick enough for a workbench.



Quartersawn Look. By cutting the boards below to reveal straight-grained edges, you can reassemble them into attractive, stable panels.

best-built jigs & fixtures

dust-free Blade Cover

Stop dust in its tracks. All it takes is a weekend and an ordinary shop vacuum crevice tool.

■ The blade cover and splitter assembly that comes with most table saws is a hassle. So I'll admit that it's not on my saw as often as it should be. Besides being unsafe, this setup also throws a lot of dust back in my face as I'm cutting.

I've been thinking about a solution for this problem for some time. The answer came when Robert Knox of Apopka, FL sent me some photos of a blade cover he made for his saw. So I borrowed some of his ideas to make the blade cover you see in the photo above.

Dust Collection. There are two things that set this blade cover apart. First, it has a simple, built-in dust collection system. This makes for dust-free cutting and goes a long way toward keeping your shop cleaner.

Over-Arm Design. The other interesting feature of this cover is that it's suspended over the blade (not attached behind it). It's connected to the right side of the saw table. This makes it easier to move the cover out of the way to change blades or for cutting tall stock.



▲ **Rigid Support.** A beefy hardwood mast and steel conduit anchor the dust cover to the saw table.

Summary first. Before getting started, there's an important safety note I should mention. The blade cover is designed to capture dust and acts as a visual reminder to keep your hands away from the blade. But it doesn't prevent kickback, so you'll want to make sure to install a separate splitter on your saw in addition to the cover.

MAKING THE HOOD

The cover consists of two main assemblies: the hood and the mounting assembly. The hood is designed to cover the blade to allow dust to be picked up by a shop vacuum crevice tool.

Since the design and installation of the mounting system depends on your saw, I'll hold off on talking about that until later and start with making the hood.

Wood Components. The hood is made up of just a few parts. A pair of polycarbonate sides surround the blade. And a couple of pieces of hardwood act as spacers, as you can see in Figure 1.

The back spacer is shaped to match the curve of the blade and channels dust and chips toward the front of the hood. At the back of the assembly, you can see this piece is raised above the table to allow for a splitter.

The front spacer directs dust up into the vacuum crevice tool,

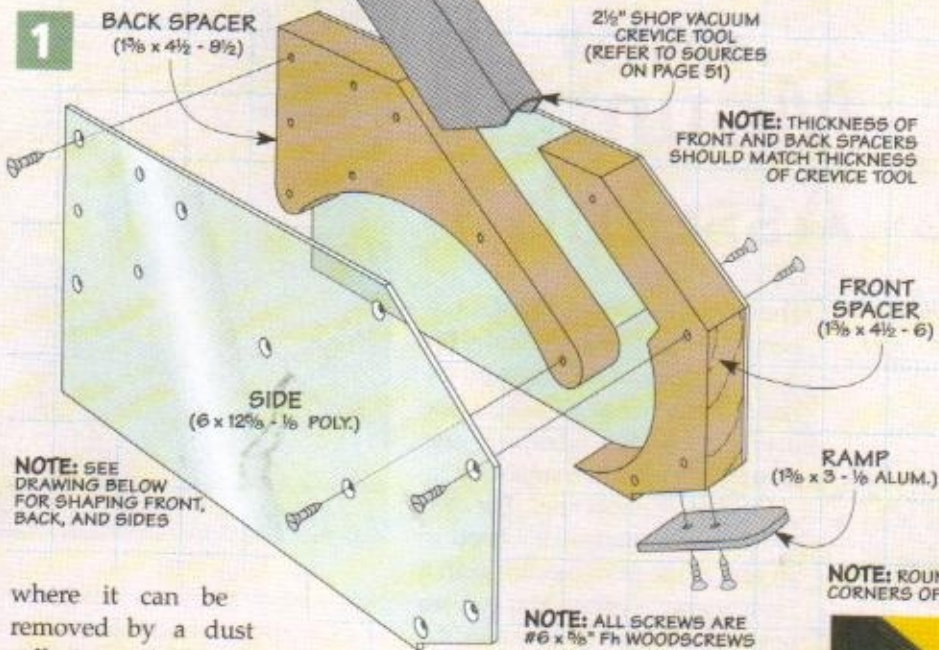

where it can be removed by a dust collector or shop vacuum. You can use the layout guide below to shape these pieces.

I sized the thickness of these pieces based on the thickness of the crevice tool. Just be aware that most crevice tools taper slightly. You're aiming for a snug fit between the sides.

Drilling Holes. After spraying on a few coats of paint, you're ready for some assembly. The sides are simply screwed to the front and back spacers.

In addition to drilling holes for the screws, you can see in the box below that there are a few other holes to drill as well. These will be used later to attach the hood

to the mounting assembly. There's also a hole for a pin that will be used to retract the hood when changing blades or cutting thick stock (photo at right).

Aluminum Ramp. The last thing to take care of on the hood is to add an aluminum ramp to the front. This ramp serves a couple of purposes. First, it provides a smooth, durable surface to allow the workpiece to slide under the hood. And second, it acts as a convenient handle to lift the hood out of the way. With the hood complete, you can get started on the mounting assembly.

NOTE: ROUND OFF CORNERS OF RAMP



▲ **Ramp.** A piece of aluminum provides a smooth, durable surface to guide the hood over a workpiece.

Blade Hood Layout

You can use the drawing at right for a couple of steps in making the hood. First, you can lay out the profile of the front and back hardwood spacers on a single, large blank.

After cutting the back spacer to shape, you'll need to custom fit the front spacer to your crevice tool. To do this, tape the pieces to one of the sides. Then set the crevice tool on the front edge of the back piece and trace its profile on the front piece. I cut the profile into the front at the band saw, but a jig saw would also work just fine.

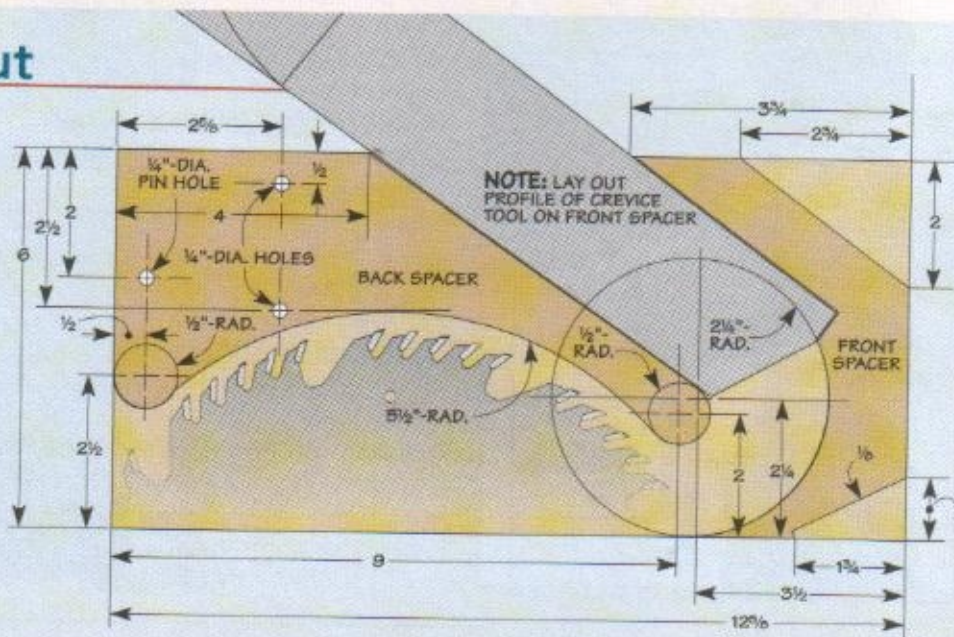

making the Mounting Assembly

NOTE: START WITH 1 5/8" x 3" - 10" BLANK

5/16"-DIA. HOLE, 3/4" DEEP (TOP SIDE)

1/4"-DIA. HOLE

1 1/2"-DIA. HOLE

1/4"-DIA. HOLE

2 3/4"

1/2"

CUT BLOCK IN HALF

DRILL TWO HOLES FOR #10 SCREWS ON BOTTOM SIDE (SEE FIG. 2)

The hood you just completed is suspended above the saw blade by the mounting assembly. However, the hood also needs to be able to ride over the top of a workpiece and then drop back down smoothly.

Flexible Connection. For this to happen, I attached the hood to an arm made from conduit with a "suspension" system. You can see how this is accomplished in the photo at right. A set of four aluminum bars connect the hood to a pair of mounting blocks that clamp onto the conduit arm.

Mounting Blocks. The hardwood mounting blocks need to grip the conduit arm securely. To make this work, start by cutting an oversize blank to the size shown in the margin drawing at left. Then you'll need to drill a few holes.

The first hole is sized to allow the conduit to pass through easily (mine was 1 1/2" dia.) The next hole to drill will be used for a carriage



Suspension System.

Aluminum bars and a compression spring allow the hood to ride over a workpiece.

bolt, washer, and knob to hold the block in place. A third hole is a storage spot for a pin that can be used to hold the hood above the saw table, as in the photos below and Figure 2. A final set of holes is used to attach the aluminum bars.

The next step is to assemble the block on the conduit. For this, I cut the block in two. A pair of screws runs through the front of the two blocks to hold them together with a 1/8" gap. Then when the knob is tightened, the blocks flex and squeeze the conduit (End View).

Aluminum Bars. When you've completed the block, you can use

the aluminum bars to attach the hood. You'll notice that two of the bolts are longer than the others. The reason is that they provide anchoring points for a spring that will provide a little assist to help the hood lift over a workpiece.



Thick Stock. Placing a cut-off bolt between the pivoting bars raises the hood slightly for thick stock.

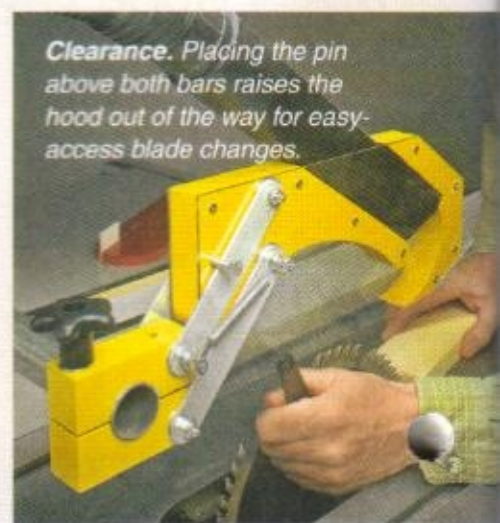

Clearance. Placing the pin above both bars raises the hood out of the way for easy-access blade changes.

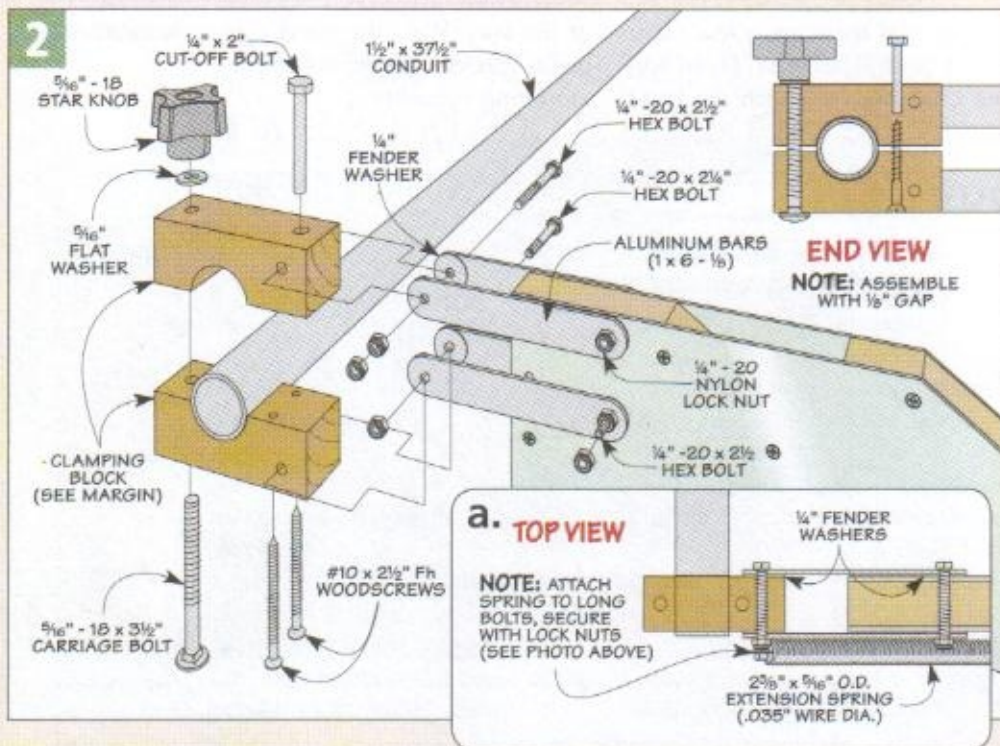

MOUNTING THE ARM

At this point, you're ready to make the connection between the mast, the arm, and the saw. Here's where you'll need to take a look at how your saw is made.

If your saw has a solid, cast iron wing or an extension table, you can use the setup shown in Figure 3. If you're using short cuts on page 15, you'll find an alternate mounting option for saws with front and rear-mounted rip fence rails.

How It Works. In a nutshell, here's how the arm is attached. The conduit arm is clamped in a hardwood mast with a carriage bolt, washer, and knob. The mast is slotted to fit over the edge of the saw table. It's designed to position the center of the arm about 5" above the saw table.

Using a knob and bolt to attach the arm allows you to quickly slide the blade cover out of the way. This will come in handy for cutting tall workpieces — like raised panels.

Hardwood Mast. After making the mast, you're ready to secure it to the saw. And it's fastened in two places for rigidity. I used a carriage bolt to attach the mast to the

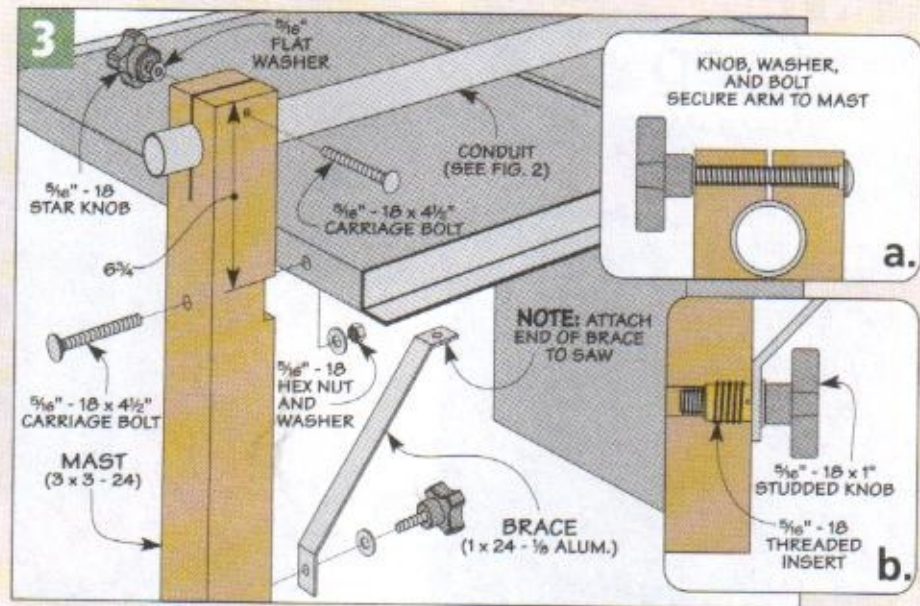

edge of the saw table. To locate the front-to-back position of the mast, set it so that the hood is centered over the saw blade. (You may have to drill a hole in the saw table.)

Bracket. The second place the mast is secured to the saw is at the bottom. Here, I made a bracket from a length of aluminum bar stock, as you can see in Figure 3. This braces the mast to keep the arm from sagging (Figure 3b). Once again, depending on what

kind of saw you have, you may need to customize the connection of the bracket to the saw.

That wraps up the construction of the blade cover. And now you can attach a vacuum hose to the crevice tool in the hood and start using it. But there are a couple of accessories in the box below that may make using the blade cover easier. And I'm sure you'll find that cutting with your table saw will be virtually dust-free. 🛠️

Blade Cover Accessories

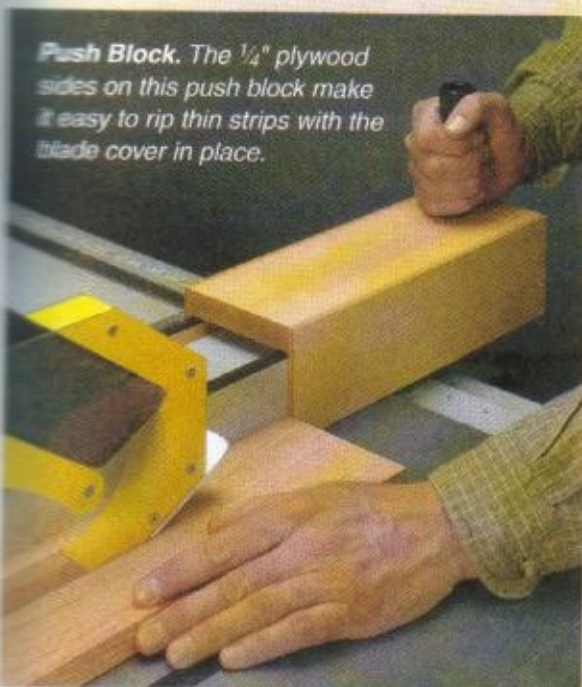

Push Block. The 1/4" plywood sides on this push block make it easy to rip thin strips with the blade cover in place.

Here are a couple of ways to extend the versatility of the blade cover.

Push Block. The 12"-long push block that rides the rip fence in the photo allows you to guide a workpiece past the blade for making narrow parts.

The push block is sized to fit easily over the rip fence without any play. And a tall handle makes it easy to control.

Blast Gate. You can also connect the blade cover to a dust collector through a blast gate attached to the edge of your saw table. The drawing at right gives you the details.

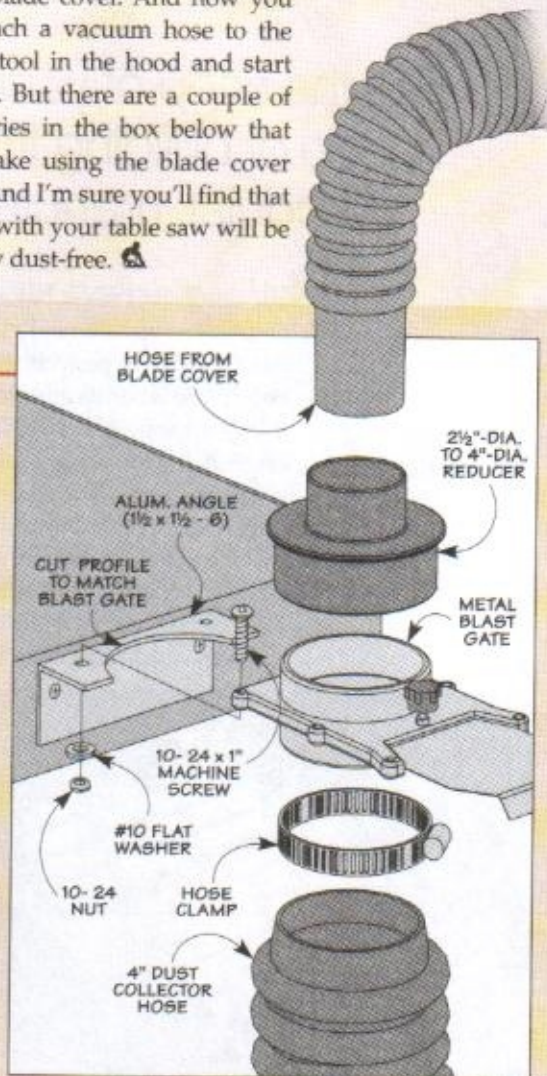

IN THE
Shop

pre-fab

Shop Cabinets

Get the shop of your dreams without the hassle of building from scratch by using modular, manufactured cabinets.

■ The one thing I never have enough of in my shop is time. I've always got a long list of projects waiting to be built. So when it came time to get things organized and build storage cabinets for the shop, I decided to save some time and order a few cabinets from a manufacturer.

It's a tough choice for a woodworker to make, but when you look at the cost of building shop cabinets (including labor in the

equation), you'll see there are good reasons to consider this option.

For example, the cabinets for the one-wall workshop on page 16 cost about \$750 (shipping included). To build the cabinets from scratch would have cost around \$350, but would have added a couple weeks of shop time to the project. Having the parts cut and pre-drilled for hardware allowed me to put them together in no time.



▲ **Finished Look.** Modular cabinets can be configured for just about any look or layout.

Designs. Another advantage you'll see right away is the design assistance available through many of the internet or catalog cabinet suppliers. This service can save hours of custom design and planning time. All you need to do is identify the space you have available and the requirements you have for the cabinets and a designer will put together a package for you.

The checklist on the opposite page is a starting point to help you figure out what questions to ask when shopping for a supplier.

Customize Your Shop. Saving time means you can spice up the cabinets with a few customized details you build yourself. In the one-wall workshop, I decided to add a flip-up workbench with a vise and pegboard panels between the cabinets. I also added the open "cubbies" above the lower cabinets to hold some of my frequently

What's In The Box

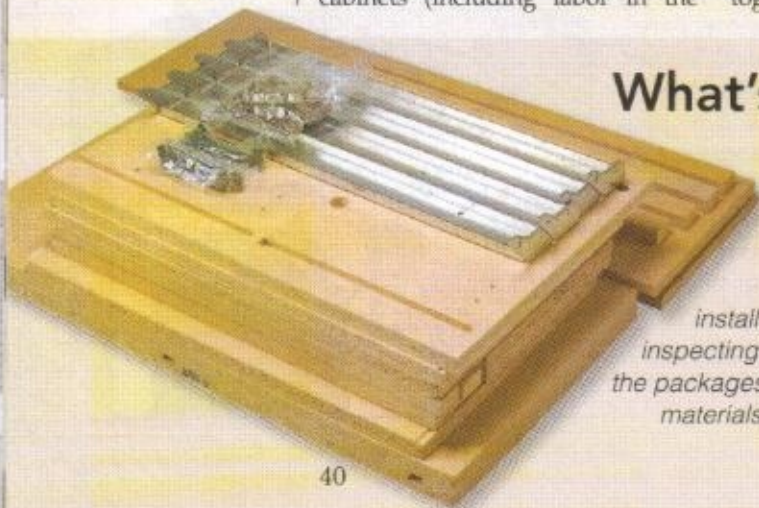

◀ **Flat Pack.**
A successful installation begins by inspecting the contents of the packages containing the materials and hardware.



▶ **Hardware.**
Kits include hinges, handles, and the screws required for assembly.

Cabinet Checklist

REQUIREMENTS

- Do you have special weight requirements?
- Do you need melamine surfaces?

DESIGN ASSISTANCE

- Does the manufacturer provide custom-built cabinets or modular units to fit your space?

CONSTRUCTION QUALITY

- What are the cabinets made of? Plywood, sheet metal, particleboard, MDF?
- What kind of hardware is used? Will you need to upgrade handles, latches, hinges?

SHIPPING & DELIVERY

- Will the products be delivered to your door or to a local vendor or warehouse?
- What's the manufacturer's policy on replacing components damaged in shipping?

INSTALLATION

- What method is used for hanging cabinets?
- Does the company offer installation?

CUSTOM MODIFICATIONS

- How easily can you add your own features or upgrades to the cabinets?



Hanging Base Cabinets. To avoid moisture damage and to make cleanup easier, it helps to keep base cabinets off the floor.

essential tools and other items I wanted to be easily accessible. And in the photo above, you can see I used hanging wall cabinets. This way, the storage is up off the floor in case of water in the shop. It also makes cleaning up easier.

INSTALLATION

When your cabinets arrive, you'll be tempted to start assembling and hanging them right away. But there are a few things to do first.

Inventory. It's a good idea to take a quick inventory of the cabinet parts and hardware to make sure everything is included. If any

of the pieces are missing or damaged, now is the time to notify the supplier and order a replacement.

Read the Instructions. Once you're sure you have everything, the next step is to familiarize yourself with the assembly instructions. Each manufacturer has different procedures for assembling and hanging the cabinets. So it's best to thoroughly understand the whole process before you begin.

You may also want to take the time to paint the pieces before you begin the installation. The box below has some helpful tips for painting particleboard cabinets.

Final Touch: Painting

The manufactured cabinets I used were made of particleboard. They're plenty strong, but they can be a challenge to paint.

Fill the End Grain. The first step in the finishing process is filling and smoothing the edges. For this, I used drywall joint compound.

You can start by applying the compound with a plastic putty

knife, as shown in the left photo below. Try to push the compound into the edges as much as possible and then even it out with the knife.

Primer Coat. The next step is to put on a coat of primer. You can use either a brush or roller for both priming and painting. I like to use gray primer because one coat covers the brown particleboard very well. It also makes it a lot easier to see any spots you've missed.

Apply the Final Color. When you select the paint for the finish coat, one thing to keep in mind is the type of paint you'll need. Remember that there will be a lot of sawdust flying and you'll want to be able to clean the cabinets easily.

For that reason, I recommend a good-quality, interior paint. It's easy to wipe clean with a damp cloth and rugged enough to stand up well in the shop.



Fill. To seal the edges, force drywall compound into the voids, then sand smooth.



Prime. A coat of primer helps seal the porous surface before adding a final color coat.



Paint. Now you can finish with a coat of the color you've chosen for your cabinets.

7 must-have

Table Saw Accessories

These simple shop-made jigs and accessories make work at the table saw safer and easier.



Like most woodworkers, I use power tools every day while working on projects. But the power tool that gets the most use in my shop is definitely the table saw. Whether it's breaking down stock or making an accurate cut for joinery, the table saw is my tool of choice.

One of the things that makes my table saw so useful is the handy jigs and accessories I've built over the years. These accessories allow me to do my work at the table saw faster, with greater accuracy, and less effort. But more importantly, they make the work a lot safer.

1 Push Block

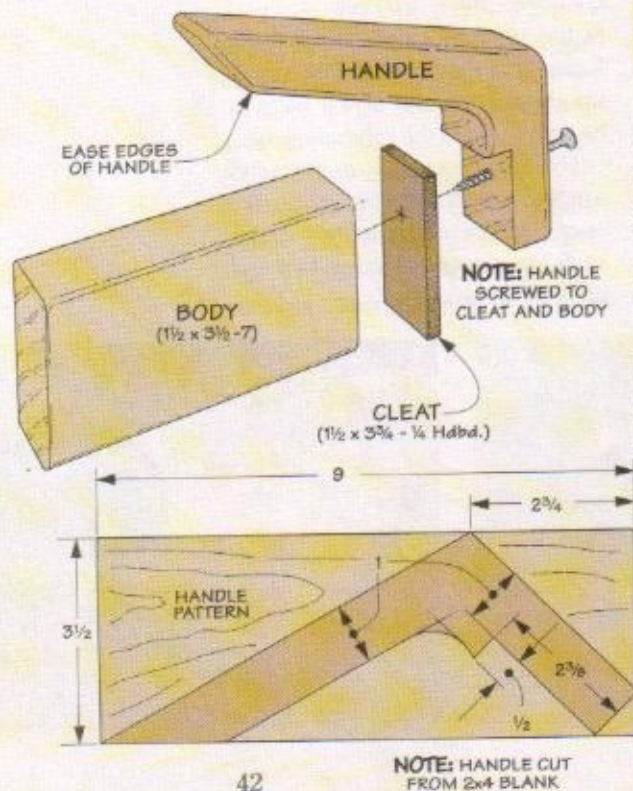

At first glance, the push block in the photo above appears to be rather simple. But don't let its appearance fool you. The right push block not only makes the work safer, it also improves the quality of your work.

One thing I like about the push block shown in the photo above is the "high-mounted" comfortable position of the handle. It keeps your

fingers well above and away from the spinning saw blade.

Best of all, you don't sacrifice any control. The forward sweep of the handle lets you place constant downward pressure on the workpiece for a steady, controlled feed into the saw blade.

As you might expect, the body and cleat are going to get chewed up after you pass them over the blade a number of times. So this push block is designed with replaceable parts. All you need to do is flip the body or cleat over when you need a new edge or simply replace them with new ones. Then you can quickly attach the handle with a screw and get back to work again.

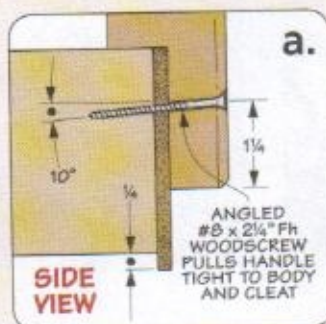

2 Auxiliary Miter Fence

The small size of the miter gauge becomes a problem with most table saws because they don't have enough surface to provide solid workpiece support. It can be a challenge to make one with any degree of accuracy.

Solving this problem is easy. Just add an auxiliary fence to your miter gauge. But if you want a fence that will provide support right up to the point of the cut, you'll need to build one that's adjustable.

As you can see, I used a rabbeted joint system to allow the fence to slide toward or away from the blade depending on the angle of the cut. And once the fence is positioned, it can be locked in place by simply tightening a couple of screws.

To build the fence, cut a rabbet along the top of the lower cleat and

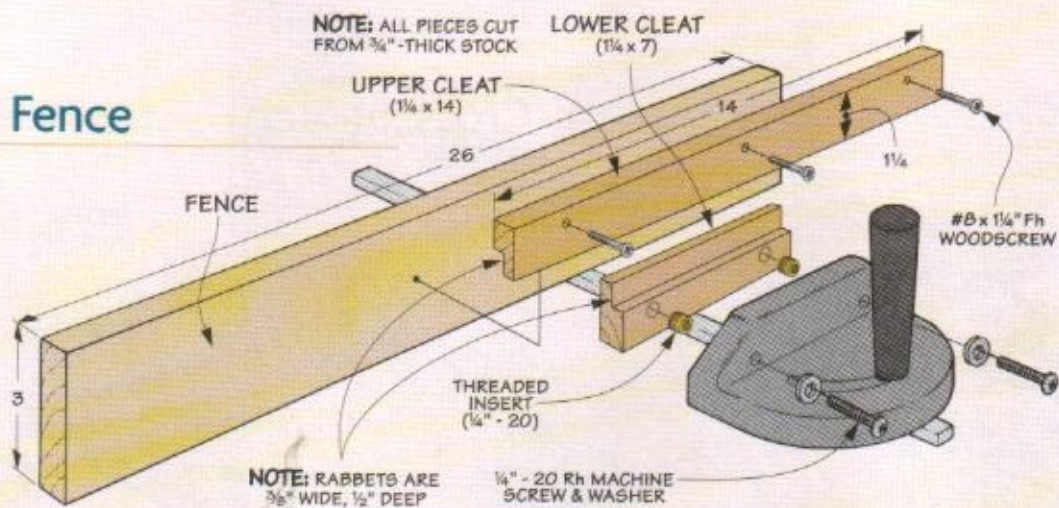

a matching rabbet along the bottom edge of the upper cleat, as shown in the drawing above. Then install threaded inserts in the lower cleat so you can attach the fence to your miter gauge (detail 'a').

The fence face can be quickly replaced when it gets chewed up. Simply remove the old one and replace it with another one.

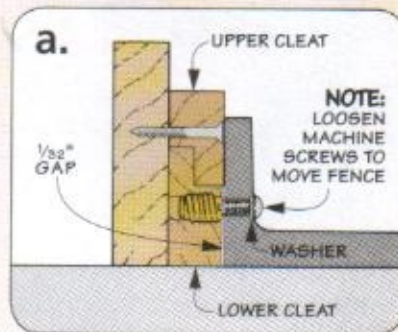

3 Stop Block

Cutting a number of pieces all to the same length at the table saw can be a challenge. No matter how accurately you line up the cut, each piece ends up a little different. But adding a stop block to your auxiliary fence, as shown in the photo at right, makes this task easy.

As you can see in the drawings below, the flip stop is fastened to an L-shaped block with a bolt and wing nut. The block is then bolted to a piece of hardboard. This forms

a clamp that fits over the auxiliary fence and can be locked in position by tightening a plastic knob. To help prevent the block from slipping on the fence, I added sandpaper along the bottom inside surface of the block and spacer.

Using the stop is easy. Just rotate the flip stop out of the way and square up one end of the workpiece. Then, you can quickly flip the stop back down to cut each piece to the same exact final length.

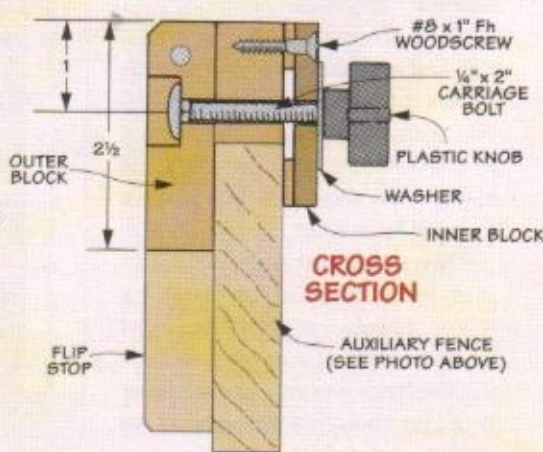
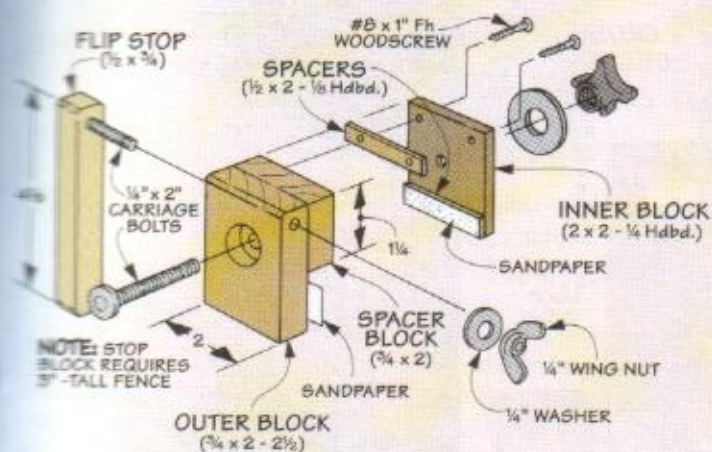
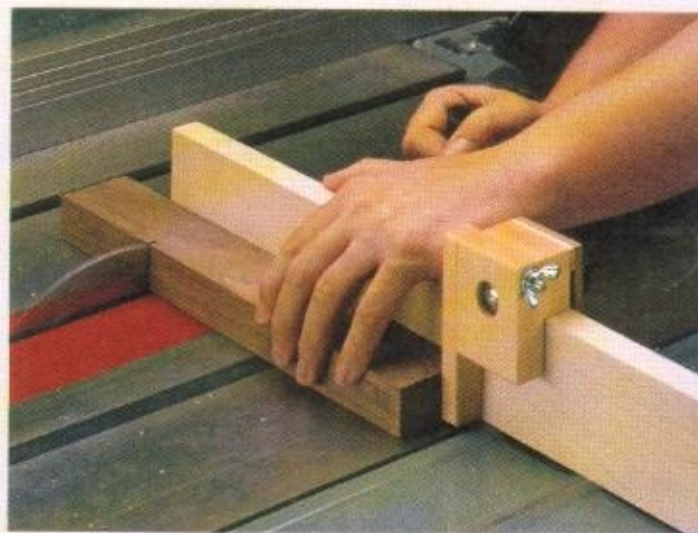

4 Crosscut Sled

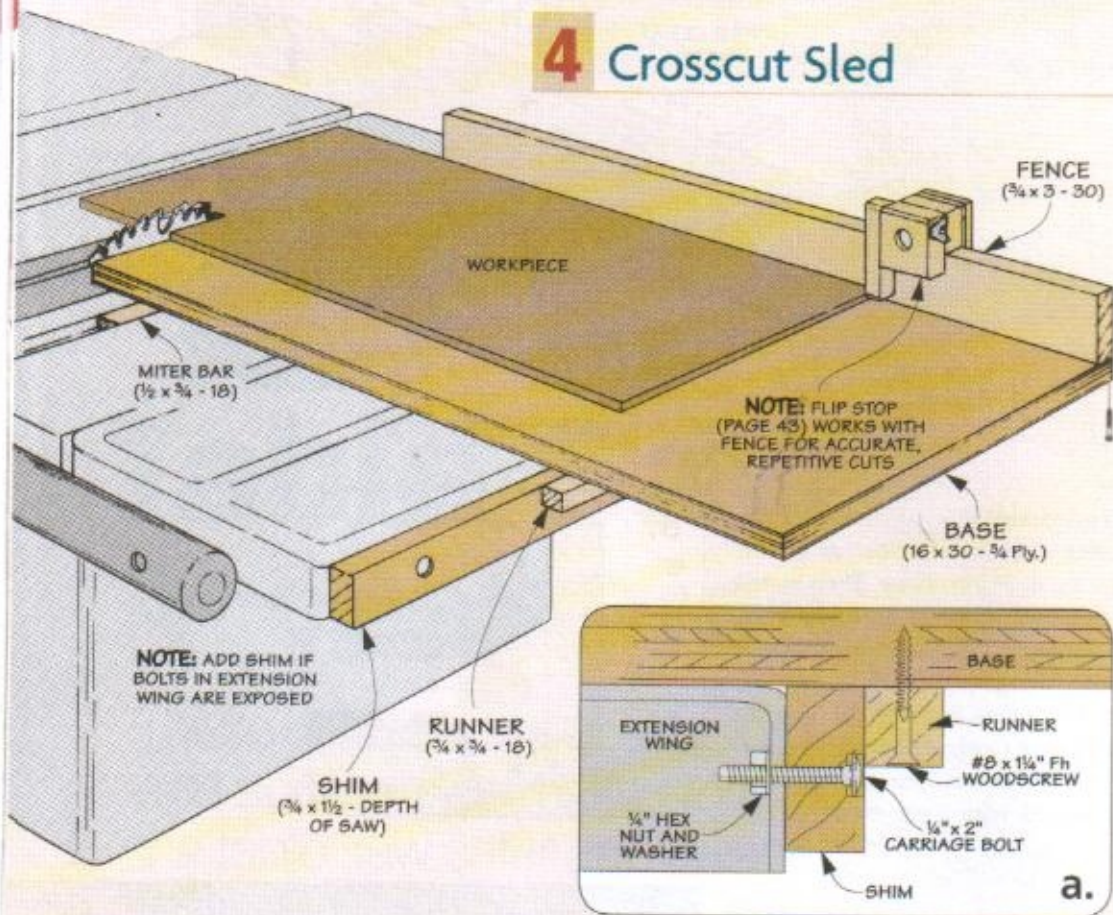

The miter gauge of your table saw works well for crosscutting most workpieces. But when you need to crosscut a large panel, you'll want to use a crosscut sled, like the one shown in the drawing at left.

The base of the sled is made from $\frac{3}{4}$ " plywood. It provides a large surface to carry the workpiece through the blade. A 3"-tall hardwood fence along the back edge holds the workpiece square to the blade during the cut. The fence is sized so you can use the same stop block built for the auxiliary miter fence on page 43.

To always give you straight and accurate cuts, the sled is guided along the table by two hardwood runners. One runner is sized to slide smoothly in the miter gauge slot in the table. And the other runner rides against the extension wing of your table saw or a shim, as shown in detail 'a' at left.

5 Auxiliary Rip Fence

A rip fence is essential for cutting workpieces to width accurately and safely. But to get more versatility from your table saw, you'll want to add an auxiliary rip fence.

The fence you see in the photo at right is sized to slip easily over the standard rip fence on your table saw. This way, it can be easily removed. But it's so handy, you might not be taking it off very often.

The fence has a short face on one side and a tall face on the other. This allows it to do double duty. When you want to use your dado blade to cut a rabbet, you can bury the blade in the short face, like you see in detail 'a' at right.

Then when you need extra support for making a cut involving larger panels or standing taller stock on end, all you need to do is flip the fence around. The tall fence provides enough solid support for you to work safely.

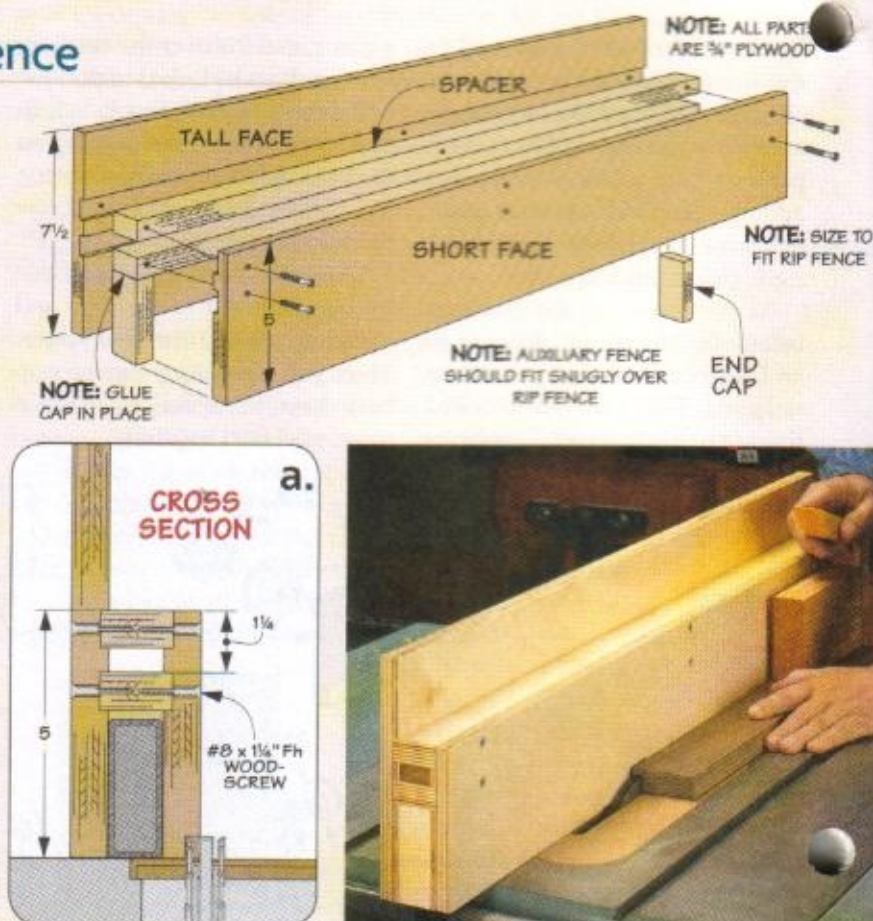

6 Outfeed Roller

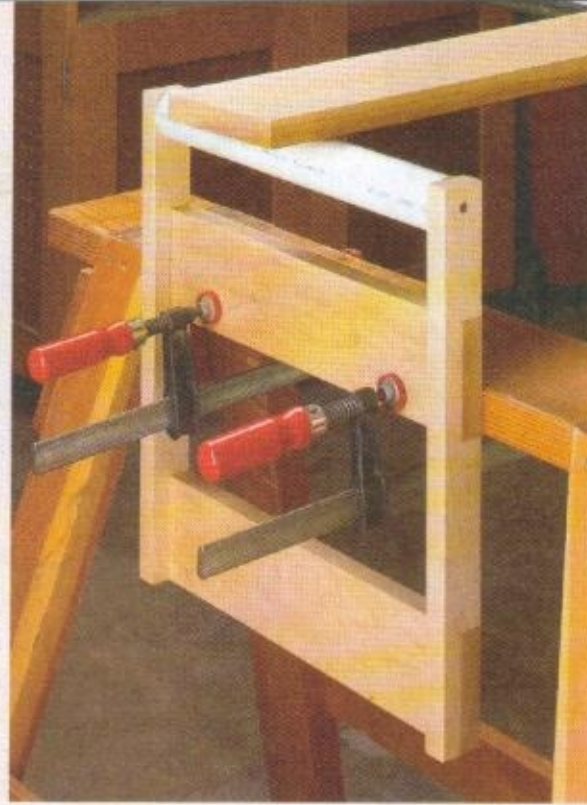
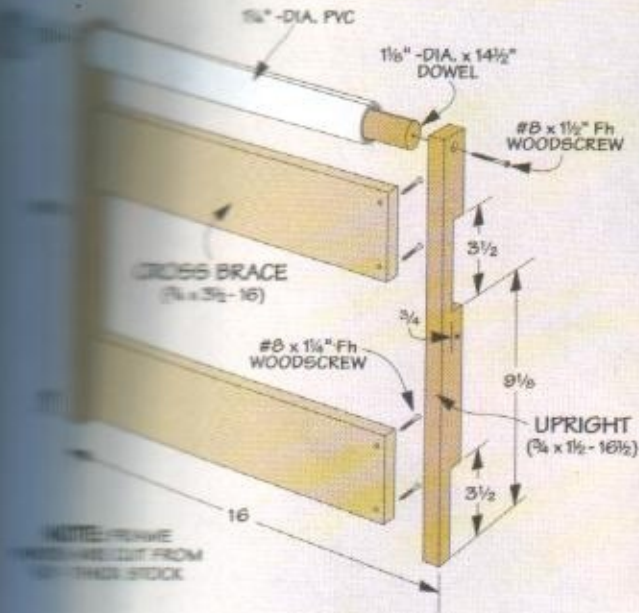

Slipping long boards or panels on the table saw can be difficult when you're working alone. You usually need a friend to help you to get the job done safely. A good outfeed support can solve this problem. And you won't need to spend a lot to meet your needs.

The outfeed roller shown in the photo above is simple and inexpensive to build. And as you can see in

the drawing above, all it takes is some scrap lumber, a short length of PVC pipe, a dowel, and a few screws.

The roller is designed to be clamped firmly to a solid support, like the sawhorse shown in the photo above. This way, once it's set up, the outfeed roller stays securely in place, and you won't need to worry about it falling over or shifting out of position.

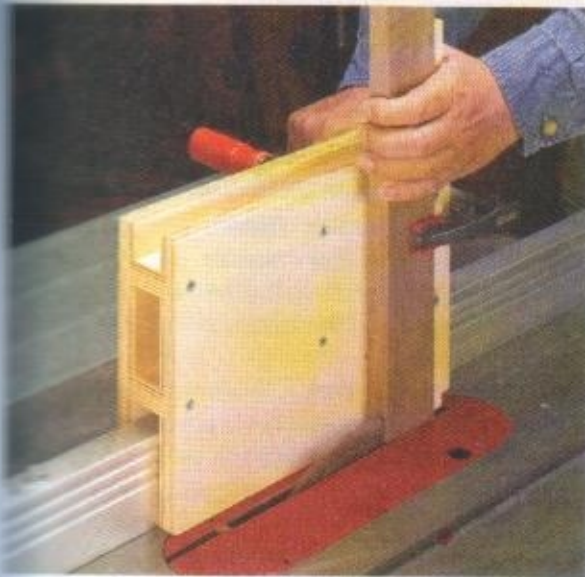

7 Tenoning Jig

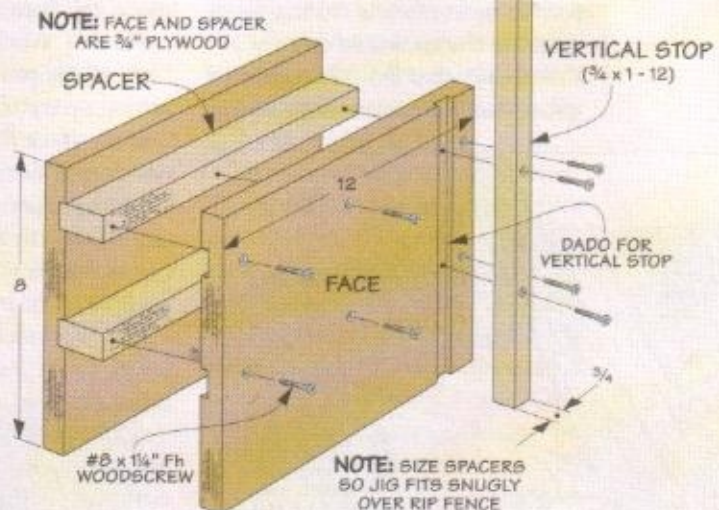

jigs that make it easier to cut tenons on the table saw are usually fairly expensive. But you can build a simple jig that works great. All it takes is a small investment in materials and little bit of your time.

If you take a look at the drawing at right, you'll see just how easy this jig is to build. It's sized to slip over and slide smoothly along the rip fence of your table saw. So all you need to do to line up a cut is simply adjust the position of the rip fence.

To build the jig, begin with two face pieces. Cut a dado in one face for the vertical stop that holds the workpiece securely in place. Then cut dadoes and add the spacers to allow the jig to fit over your rip fence.

You can use the jig to quickly and easily cut the cheeks of a tenon. But that's not all it will do. You'll find it also works great for creating smooth cheeks for a half-lap joint or cutting a bridle joint.

the easy way to

Snug-Fitting Tenons

Here's a straightforward technique that yields top-notch results.

■ Of all the specialized table saw techniques I use, the one I probably turn to most often is cutting clean, accurate tenons with a dado blade. I've found that no other method gives me the same high-quality

results in a comparable time. Best of all, the setup is easy and the technique can be mastered quickly.

How it Works. Going over the basic technique is a good lead-in to setting up the table saw. Essentially, a wide, stack dado blade does the hard work of removing the waste from the tenon cheeks and shoulders. Carefully adjusting the height of the blade is what gives you a snug fit to the mortise.

The workpiece is fed across the dado blade using an auxiliary fence attached to the miter gauge. This gives you firm, easy control and results in clean, square shoulders. Finally, the rip fence is used as an end stop to accurately gauge the length of the tenons.

Setting Up Right. Setting up the table saw to cut the tenons only takes a few minutes. A look at the photo above and the drawing at left will help you with the basics. I'll just highlight a few of the more important points.



▲ **The Result.** For tenons with smooth cheeks, crisp shoulders, and a gap-free fit, a dado blade on the table saw is the ticket.

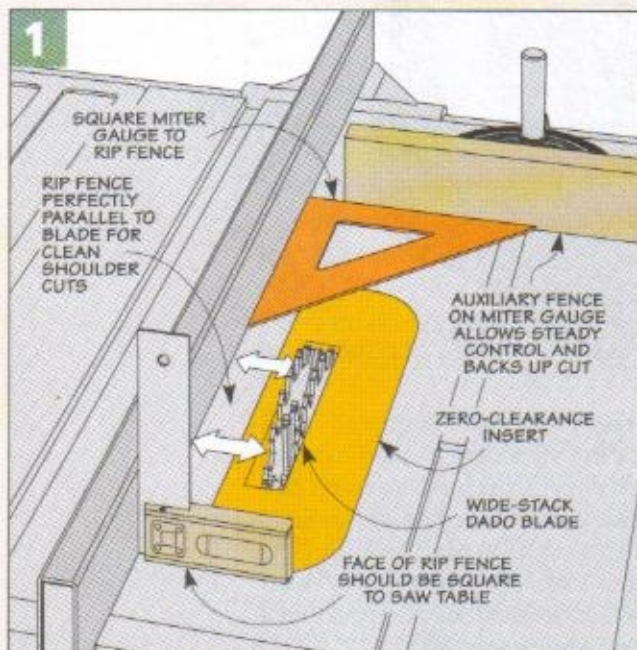

First, you want to use the widest dado blade possible. It will take fewer passes to cut the cheeks and you'll get smoother results. And I always install a zero-clearance insert over the blade to help control chipout at the shoulders.

The auxiliary fence on the miter gauge gives you better control of the workpiece and also backs up the cuts. So you want to make sure it's tall enough to give you a good grip and it's positioned to extend past the blade, as shown at left.

One of your goals is clean, square shoulders. To achieve this, first, the

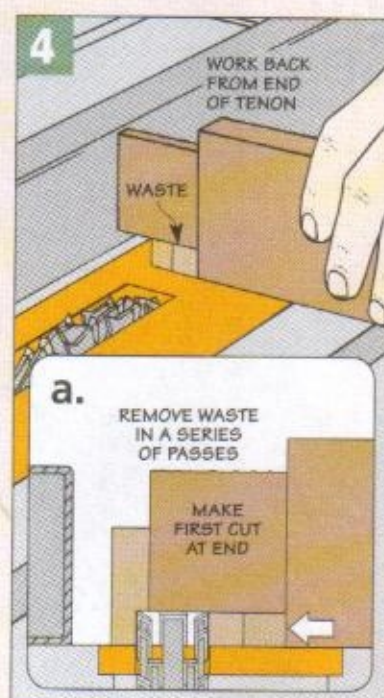
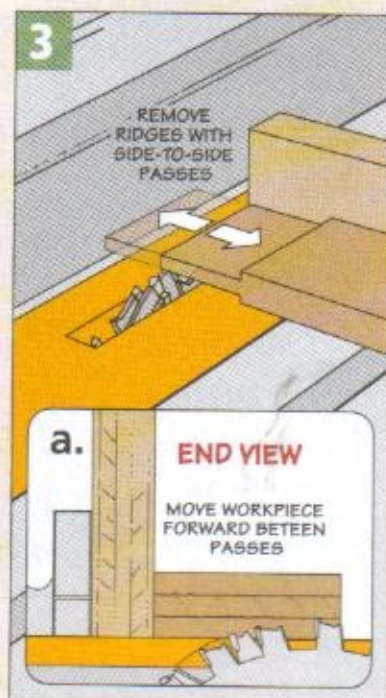
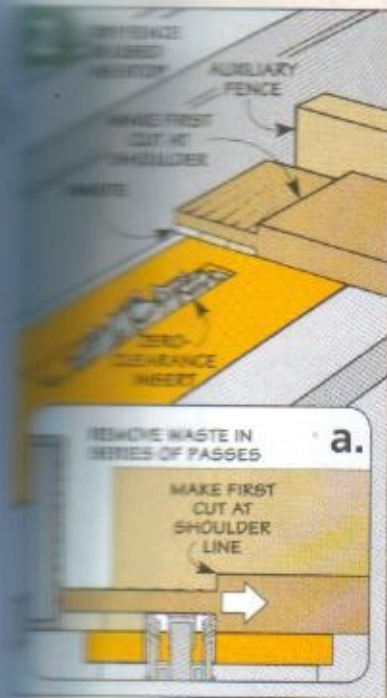

the rip fence should be perfectly parallel to the blade. And second, make sure the miter gauge is square to the rip fence and the blade.

MAKING THE CUTS

Once you're set up, cutting the tenons goes quickly. The process is shown in the drawings above.

First the Cheeks. The tenon cheeks are cut first (Figure 2). I start by using a test piece to adjust the blade height and establish the thickness of the tenons. (This can be the tip of one of your workpieces.) You'll want to have a mortised workpiece close at hand to check the fit. Your "stub" tenon should be a pretty snug fit at this point.

You'll also need to adjust the position of the rip fence to gauge the length of the tenon. But this can be done when cutting the first tenon cheek. Set the fence to cut just shy of the shoulder line and make a pass. Then tweak the fence position until the cut falls right on your line. Now, work back toward the end of the tenon with multiple passes to remove the remaining waste on the cheek (Figure 2a).

Side To Side. The dado blade often leaves small ridges on the tenon cheek. A quick way to remove these is to slide the workpiece side-to-side across the "high point" of the blade (Figures 3 and 3a). Move the workpiece forward slightly

between each pass to knock down the ridges. The opposite cheek can be cut exactly the same.

Completing the Tenon. Once all the tenon cheeks have been cut and smoothed, you complete the tenons by cutting the top and bottom shoulders. A look at Figure 4 above will give you the idea.

First, you may have to readjust the blade height to properly size the width of the tenon. You do this the same as for the cheeks, testing the fit directly to the mortise. But don't move the rip fence.

Here the order is a little different. To remove the waste, I start with a cut at the *end* of the tenon and work back toward the shoulder. This has two benefits. You'll be much less likely to chip the corners of the tenon by cutting away waste that's still supported on the "shoulder" side. Second, you can ensure that all four shoulders will be perfectly aligned by making the shoulder cuts with a final light pass. Then if necessary, smooth the face with a "sideways" pass or two.

After cutting the top and bottom shoulders, the tenon is ready to meet its mortise. It's a good feeling when the tenon slides home snugly. And you can be sure it's a joint that will last a lifetime. 🛠️

Getting a Grip

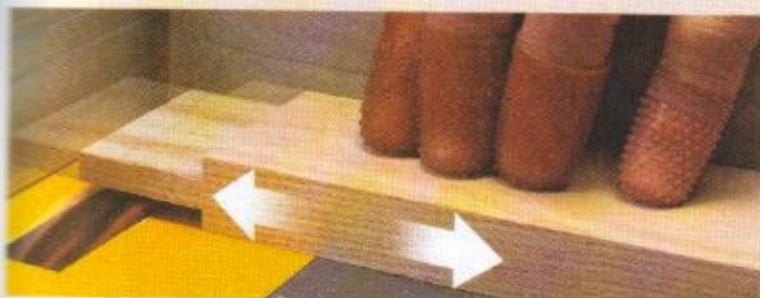

▲ **Finger Tip Control.** If you have trouble maintaining a good grip on the workpiece, a set of nubby, rubber finger tips is the answer. You can buy them in several sizes at an office supply store.

**GREAT
Gear**

Tame the dust in your shop and make more accurate cuts with these handy accessories.



miter saw
Accessories

■ I don't think a day goes by in my shop that the miter saw doesn't get used. It's great for cutting pieces to length, making angled cuts, or trimming an extra "hair" off a workpiece to get a good fit. In short, it's a shop workhorse.

But the saw by itself is more suited to a construction site than a workshop. Thankfully, the accessories pictured above can make your miter saw more accurate, safer, and more enjoyable to use.

ROUSSEAU DOWNDRAFTER

When it comes to controlling the dust clouds produced at the miter saw, I've tried just about everything. Starting with connecting a vacuum hose to the saw's dust port, and moving on to building a box to try and corral the dust. The dust seemed to win every time.

So when I saw the *Downdrafter*, I had to give it a try.

The *Downdrafter* is a dust collection hood made of impact-resistant molded plastic with a 4" dust collection port. Using the hood, your dust collector can handle even the worst dust clouds (like cutting MDF) without missing much.

Working the Angles. The problem with trying to collect dust at the miter saw is the fact that the dust exhaust changes position as you move the blade to make angled cuts. That means a fixed collection point won't do the job — especially when you angle the blade to cut at 45°. So a smart system would allow you to move the collection point with the blade. And that's exactly what the *Downdrafter* does.

Two Options. The *Downdrafter* hood is available in two models.

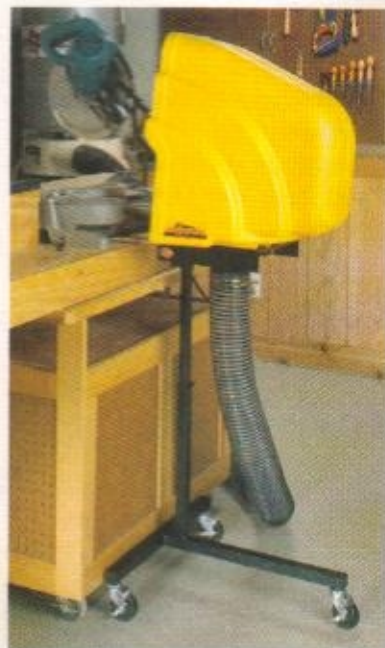

▲ **Roll It to the Source.** Sturdy construction and portability add to the *Downdrafter's* strengths.

The dust, shown in the photo at right, is on wheels. This means you can position it and swivel the wheels to match the angle of the saw to help capture the dust. It has the added advantage of being mobile, so you can move it away from the miter saw and use it near your workbench or when you're power sanding a bowl on the lathe.

Another model attaches to the miter saw on rails allowing the dust collector to move with the saw as you change angles. This option is great if your miter saw stays in a fixed location in your shop and you seldom need to move it to a job site.

Results. I found it to be very effective, with either a standard miter saw or a sliding-compound model. And the steel stand makes height adjustments easy while still providing a solid platform. You'll probably want to add a 45° PVC elbow to your saw's dust port, as shown in the main photo, to keep dust pointed into the hood. (The manufacturer recommends this modification in the instruction sheet included in the package.)

With a street price of \$150, it's not the least expensive solution for dust control. But compared to covering your shop in a layer of dust and inhaling it as well, it just might become one of the most effective.

THE KREG PRECISION MEASUREMENT SYSTEM

A popular use for the miter saw is making accurate and repetitive length cuts. Kreg has made the job a lot easier and more accurate with their *Precision Measurement System*.

The kit consists of extruded aluminum T-track designed to fit over a ¾"-thick, shop-built fence. The track comes in four 2' lengths, so you can customize a setup for your needs. The kit also includes both left and right-reading measuring tapes that fit into the T-track.

Stop Blocks. But the highlights of the system are the two stop blocks. Both slide and lock into position easily on the T-track and feature acrylic etched cursors for setting up precise cuts using the fence.

The first block is square and fixes in position like a traditional stop block. The second is a "flip-stop." Once positioned, it can be flipped back over the fence and out of the way of the worksurface. Its curved shape also allows you to slide a board under it (as shown in the top photo at right). The real advantage here comes when you're cutting different-sized pieces from a board. (For example, if you need to cut multiple 60" and 30" pieces from a set of 8' boards.) You just slide the



▲ **A Pair of Stops.** Both the flip-stop (left) and the fixed stop (right) feature an easy-to-read hairline cursor (inset above) for making accurate cuts.

board against the flip stop, make the cut, then slide it underneath the stop to the fixed block and make the next cut (photo above).

The price of the *Precision Measurement System* is also around \$150. But the accuracy and time savings can quickly justify the cost.

Bottom Line. The *Downdrafter* and *Precision Measurement System* are welcome additions to the shop. And if you cut a lot of crown molding, the box below shows another handy upgrade. You can find out where to buy these accessories in Sources on page 51. 🛠️

Accurate Cuts in Crown Molding

Benchdog Tools takes the hassle out of cutting crown molding with their *Crown-Cut* jig. The nice thing about the *Crown-Cut* is its simplicity. All you need to do is set the fence to hold the molding upside down and at the correct angle — no need to tilt the blade. The directions for inside/outside corners and left/right cuts are printed right on it to help you avoid errors. You just position the molding in the jig and then cut the miter.

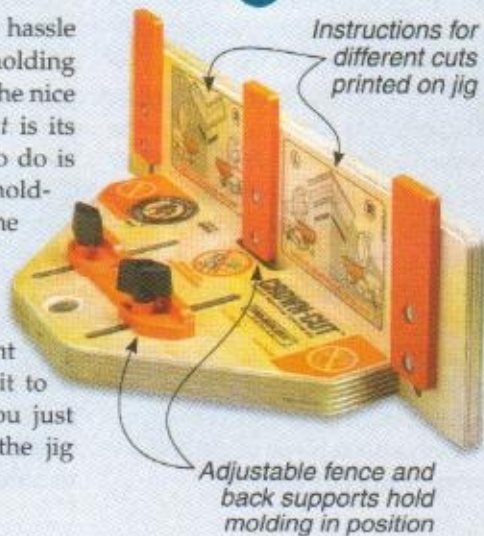

Instructions for different cuts printed on jig

Adjustable fence and back supports hold molding in position

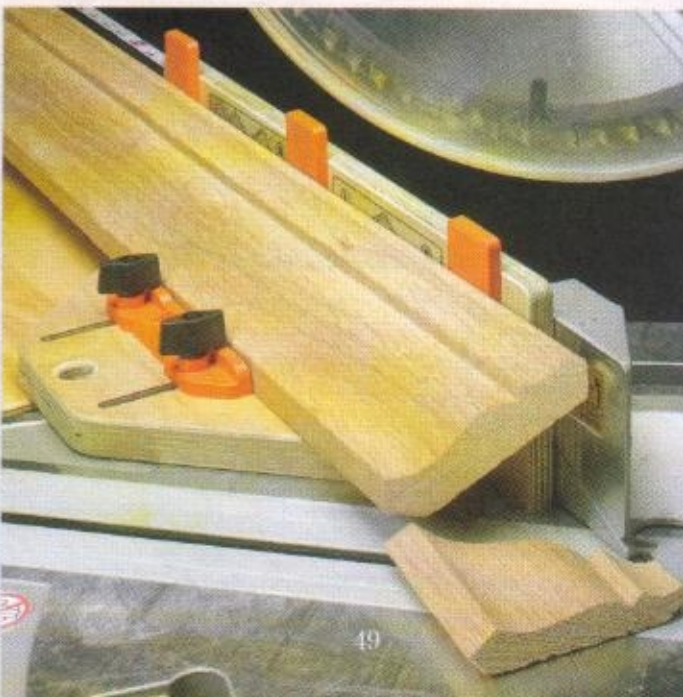



questions from Our Readers

saw blade Hook Angle

While shopping for saw blades, I've noticed that they all seem to have varying hook angles. Is one hook angle better than another?

Dino Buscetti
Bloomfield, New Jersey

■ The "hook" of a blade is simply the angle at which the teeth lean forward (or back) when looking at the blade from the side.

Blades are available in a range of hook angles. If the teeth lean forward (so that they face into the cut) the blade is said to have a positive hook angle. If the teeth

lean backward, the blade has a negative hook angle. Most saw blades for woodworking have a hook angle ranging from -5° to 20° . Determining which hook angle is best really depends upon the type of saw you're using and the work you're doing.

Miter Saw. If you're buying a blade for either a sliding compound miter saw or a radial arm saw, you'll want to choose a blade with a low or negative hook angle (between 5° and -5°). The reason has to do with control.

The higher the hook angle, the more aggressive the cut. This is because the teeth are biting into the wood at a steeper angle (drawings at left). On a miter or radial arm saw, a high hook angle can cause the blade to "grab" the workpiece and lurch forward uncontrollably. That's why a blade with a low or negative hook angle is a better choice with this type of saw.

There are a couple of downsides to using a blade with a low or negative hook angle. The lower the hook angle, the more power the blade requires to cut through the material. So if your saw is underpowered to begin with, switching to a negative hook blade might make it seem even more anemic.

The other thing to keep in mind is that you'll probably have to slow down your feed rate when using a blade with a low or negative hook angle. If you don't, you run the risk of stalling the motor.

Table Saw. If you're buying a blade for the table saw, you'll want to select one with a high hook angle (anywhere from 10° to 20°). The higher hook angle will allow you to feed the wood into the blade faster. And since the blade on a table saw remains in a fixed position, there isn't really any danger of the blade self-feeding into the workpiece. You simply control the cutting speed by adjusting the feed rate of the workpiece.

Material. In addition to the type of saw you're using, you'll also want to consider the material you're cutting. Generally speaking, the harder the material, the lower the hook angle you want to use.

For cutting softwoods on a table saw, a blade with a 20° hook is a good choice. With hardwoods, you'll want to use a blade with a 10° or 15° hook. And if you're cutting plastic laminates or non-ferrous metals, your best bet is a blade with a negative hook angle, whether you're using a table saw or a miter saw. 

► Teeth with low or negative hook angle strike wood squarely.

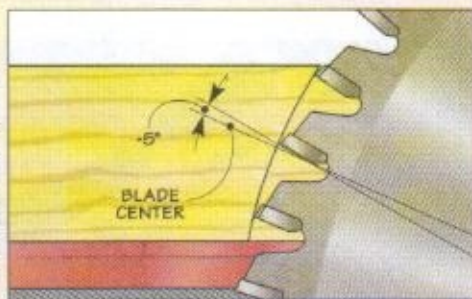

► Teeth with positive hook angle "bite" into wood.

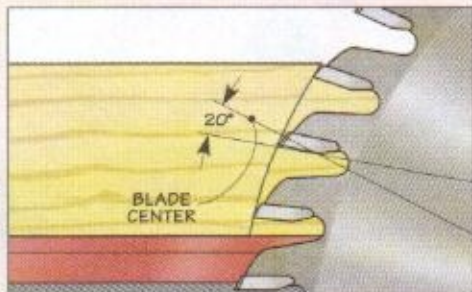

Sources

HANG IT ON A WALL

Mounting a cabinet to a wall is a challenge if you don't have a wall stud in the right place. The solution is a wall anchor, like the ones featured on page 10. If you have trouble locating them at a local hardware store or home center, check with *McMaster-Carr* (margin at right).

PLYWOOD EDGING BITS

Covering up the edges of plywood can be a hassle. But with the *Burgess Edge* bits shown on page 12, it's quick and easy to cut mating profiles that match perfectly. These sets are available for both 1/2"-thick and 3/4"-thick material. The adjustable bullnose profile bit is available for only the 3/4" material.

All the bits are available from the *Burgess Edge*. And *Lee Valley* carries the bits for 3/4" material (16J94.01, 16J94.03). *Rockler* has the bits for both 1/2" (26018) and 3/4" (25854) stock. Check out the margin at right for ordering information.

ONE-WALL WORKSHOP

The cabinets for the one-wall workshop on page 16 were obtained from *Garage Storage Cabinets*. Contact information is in the margin.

To customize the project, you'll also need additional items. The face vise (68888) was ordered from *Rockler*.

And *Woodworker's Hardware* carries the wire pulls (A7631326D) we swapped out on the cabinet doors.

If you plan to add lighting, we used 48" *GE Premium Direct Wire Fluorescents* and 13" *GE Advanced Linkable Halogen Lights* from a local home center.

For the tail vise, you'll need a 9" press screw (13F17.01) and *Veritas Bench Pups* (05G04.04) from *Lee Valley*. And if you decide to build the workbench without the tail vise, the *Veritas Wonder Pup* (05G10.02), along with one bench pup (05G04.03), will make any clamping task simple.

Finally, to paint the cabinets, we used *Lady Bug Red* (1322) in *Eggshell AquaVelvet* and *Antique Parchment* (959) in *Satin Impervo*. Both are available from a *Benjamin Moore* dealer. To prepare the surface of the cabinets, we used a fast-drying, oil-based primer with a gray tint.

CLEANUP CENTER

All the hardware for the cleanup center on page 30 is pretty common. The only challenge may be finding the 30# kraft paper roll used to protect your benchtops and worksurfaces.

Centralpack.com offers the 30"-wide roll as item number 35961. But similar rolls are available from

a number of sources, including *Office Depot* and *McMaster-Carr* listed in the margin at right.

TABLE SAW BLADE COVER

The shop-made blade cover shown on page 36 is a great way to improve the dust collection from your table saw. A hardware store will carry most of what you need. For the knobs (23812), contact *Rockler*. And if you need the crevice tool (*Ridgid* VT2502), check with *Home Depot*.

MITER SAW UPGRADES

Whether you're cutting stock to rough length or trimming off a hair for a perfect fit, a miter saw can't be beat. For even more versatility and accuracy, you can add upgrades like the ones on page 48.

The *Downrafter* is available from a couple of the sources listed at right. The *Amazon* item number is B0006FRAVQ. And if you order through *Eagle America*, ask for item number 485-3870.

The *Kreg Precision Measurement System* is available from a number of mail-order sources, including *Rockler* (29415), *Woodcraft* (146487), and the *Woodsmith Store*. And finally, the *Crown-Cut Jig* from *Bench Dog Tools* is available from both *Amazon* (B0006FKGGC) and the *Woodsmith Store*.

MAIL ORDER SOURCES

Woodsmith Store
800-444-7527

Benjamin Moore Paints, Crown-Cut Jig, Knobs, Kreg Precision Measurement System, Talon Pegboard Hooks, Veritas Bench Pups & Wonder Pup

Rockler
800-279-4441
rockler.com

Face Vise, Knobs, Kreg Precision Measurement System, Plywood Edging Bits, Talon Pegboard Hooks

Lee Valley
800-871-8158
leevalley.com

Plywood Edging Bits, Press Screws, Veritas Bench Pups & Wonder Pup

The Burgess Edge
802-233-1489
burgessedge.com

Plywood Edging Bits

McMaster-Carr
630-600-3600
mcmaster.com

Kraft Paper Rolls, Springs, Wall Anchors

Amazon.com

Downrafter, Crown-Cut Jig

Eagle America
800-872-2511
eagleamerica.com

Downrafter

Woodcraft Inc.
800-225-1153
woodcraft.com

Kreg Precision Measurement System

Woodworker's Hardware
800-383-0130
wwhardware.com

Wire Pulls

P&M Consolidator Supply Co.
888-654-5354
centralpack.com

Kraft Paper Rolls

Office Depot
800-463-3768
officedepot.com

Kraft Paper Rolls

Bench Dog Tools
800-786-8902
www.benchdog.com

Crown-Cut Jig

Garage Storage Cabinets
866-414-4844
garagestoragecabinets.com

Cabinets

ShopNotes Binders

Keep your issues organized!

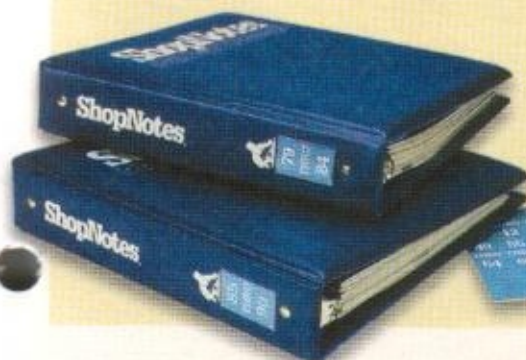

As you build your *ShopNotes* library, here's a way to keep your issues organized. Each binder features durable vinyl covers and easy-to-read perforated number tags. Snap rings with a quick-open lever make it easy to insert and remove issues. And there's an extra pocket inside for storing notes. Each binder holds a full year (6 issues) of *ShopNotes*.

Visit www.ShopNotes.com to order these binders, or call 1-800-444-7527.

ShopNotes Binder

○ 701950-SN92 (Holds 6 issues).....\$12.95



Scenes from the Shop

TABLE SAW BLADE COVER pg 36

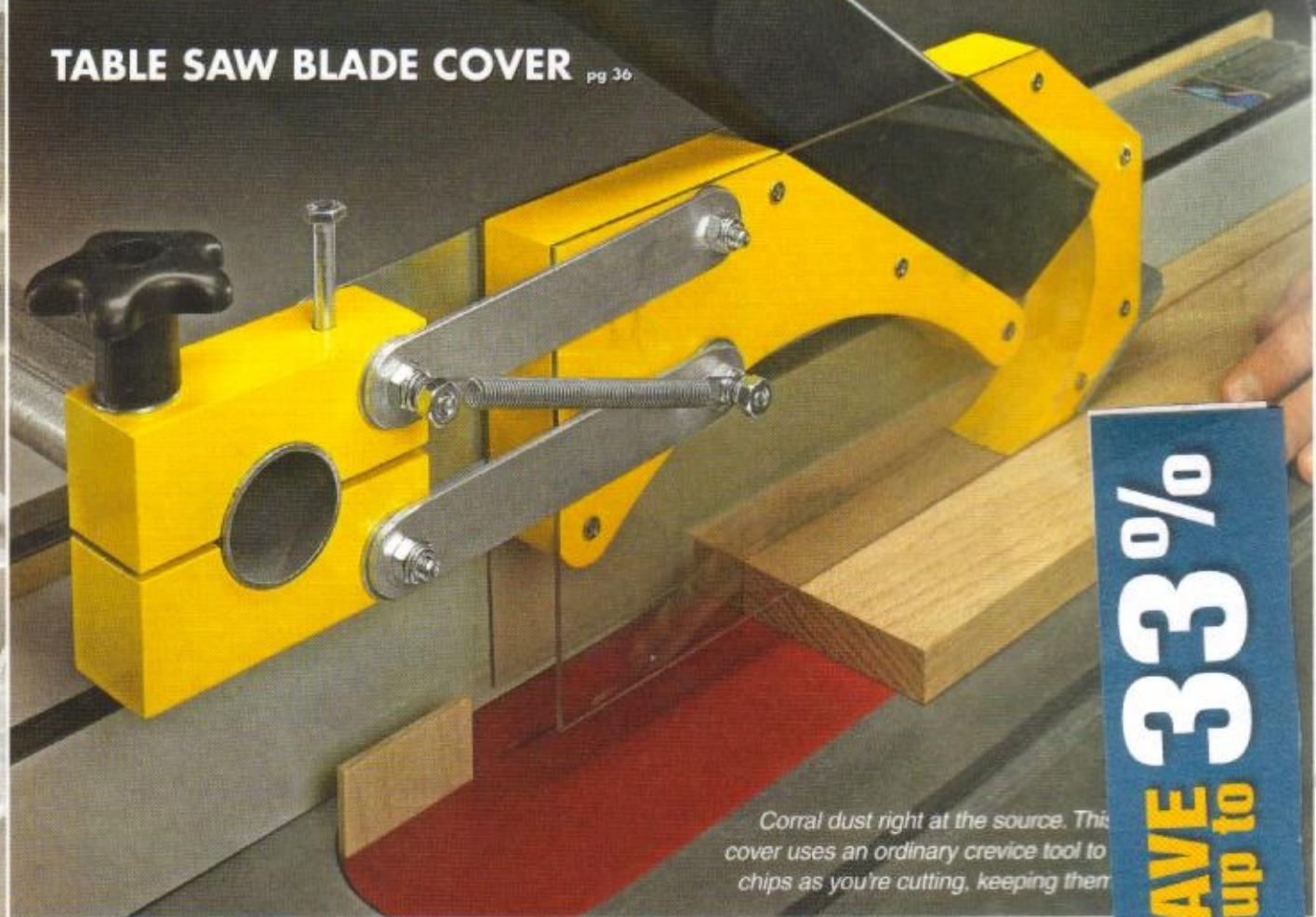

Corral dust right at the source. This cover uses an ordinary crevice tool to chips as you're cutting, keeping them

SAVE
up to **33%**

TIPS & TECHNIQUES pg 6

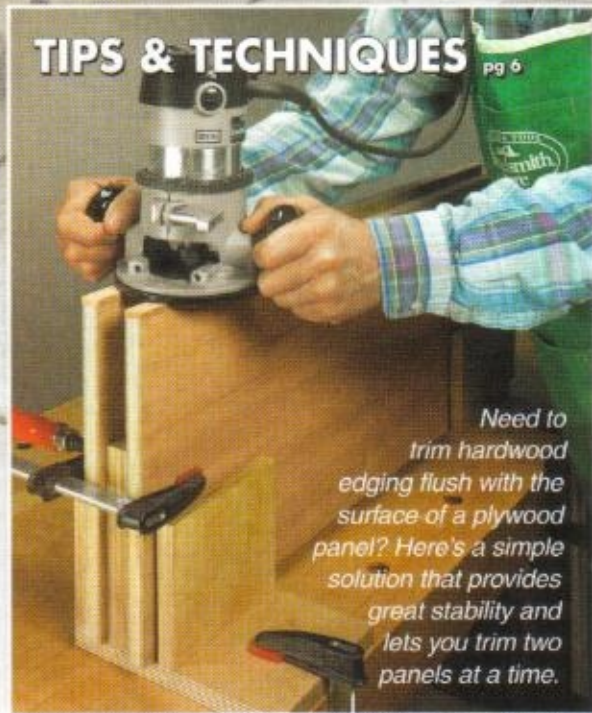

Need to trim hardwood edging flush with the surface of a plywood panel? Here's a simple solution that provides great stability and lets you trim two panels at a time.

PERFECT TENONS pg 46



Snug-fitting mortise and tenon joints are a hallmark of good craftsmanship and long-lasting projects. We'll show you a straightforward table saw technique for cutting flawless tenons without a lot of hassle or complicated setups.

shop-built **Cleanup Center**

Materials

CASE

A	Back (1)	31 x 35 - $\frac{3}{4}$ Ply.
B	Sides (2)	12 $\frac{1}{4}$ x 35 - $\frac{3}{4}$ Ply.
C	Peg Rail (1)	2 $\frac{1}{2}$ x 30 $\frac{1}{2}$ - $\frac{3}{4}$ Ply.
D	Pegs (5)	$\frac{1}{2}$ x 4 $\frac{1}{4}$
E	Shelves (2)	11 $\frac{3}{4}$ x 31 - $\frac{3}{4}$ Ply.
F	Left Face (1)	4 $\frac{3}{4}$ x 10 $\frac{1}{4}$ - $\frac{3}{4}$ Ply.
G	Right Face (1)	4 $\frac{3}{4}$ x 8 $\frac{3}{4}$ - $\frac{3}{4}$ Ply.
H	Side Dividers (2)	4 $\frac{3}{4}$ x 10 $\frac{3}{4}$ - $\frac{3}{4}$ Ply.
I	Middle Divider (1)	4 $\frac{3}{4}$ x 12 - $\frac{3}{4}$ Ply.

J	Paper Towel Bar (1)	1 x 12 $\frac{1}{2}$
K	Cutter Arms (2)	1 $\frac{1}{2}$ x 8 $\frac{1}{2}$ - 1 $\frac{1}{2}$ Ply.
L	Roller Bar (1)	1 x 31 $\frac{1}{2}$

- (1) 1 $\frac{1}{2}$ " x 1 $\frac{1}{2}$ " - 30 $\frac{1}{4}$ " Angle Iron
- (27) #8 x 1 $\frac{1}{2}$ " Fh Woodscrews
- (2) #8 x 1" Fh Woodscrews
- (2) #10 x 2" Fh Woodscrews
- (1) Roll of 30"-wide Kraft Paper

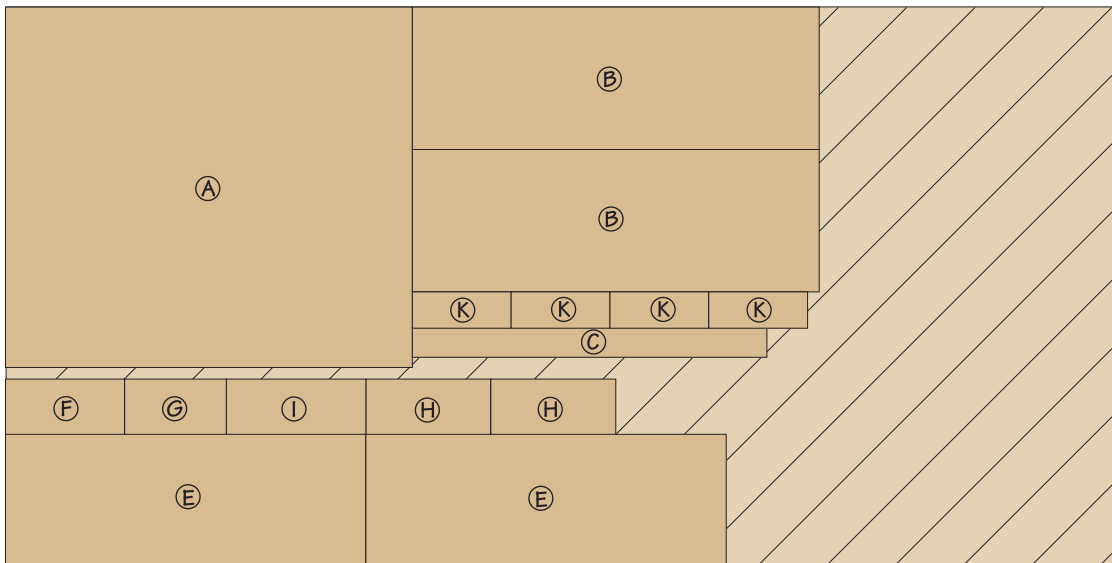

48" x 96" - $\frac{3}{4}$ " PLYWOOD

ALSO NEEDED: (1) $\frac{1}{2}$ " x 24" Dowel for Pegs
 (1) 1" x 48" Dowel for Paper Towel Bar and Roller Bar

One-Wall Workshop

Materials

STORAGE CABINET WORK AREA

A	Top	16 x 71 - 3/4 MDF
B	Bottom	15 1/2 x 71 - 3/4 MDF
C	Left/Right End (2)	13 5/8 x 16 - 3/4 MDF
D	Dividers (2)	11 7/8 x 15 1/4 - 3/4 MDF
E	Back	13 1/8 x 71 - 3/4 MDF
F	Bottom Fillers (2)	3/4 x 1 1/2 - 70 1/2
G	Face Frame Rails (2)	3/4 x 1 1/2 - 69
H	Face Frame Outer Stiles (2)	3/4 x 1 1/2 - 13 5/8
I	Face Frame Center Stiles (2)	3/4 x 1 1/2 - 10 5/8
J	Tops (2)	18 1/2 x 72 - 3/4 MDF
K	Front Edging	3/4 x 1 1/2 - 72 3/4
L	End Edging	3/4 x 1 1/2 - 19 1/4
M	Bottom Panel	12 x 72 - 3/4 MDF

N	Panel Blocking (2)	1 x 1 1/2 - 72
O	Panel Edging	1 3/4 x 72 - 3/4 MDF
P	Top Panel	18 x 72 - 3/4 MDF
Q	Front Light Rail	2 1/4 x 72 - 3/4 MDF
R	Pegboard	18 x 72 - 1/4 Pgbd.
S	Horizontal Spacer (2)	3/4 x 1 1/4 - 72
T	Vertical Spacers (2)	3/4 x 1 1/4 - 15 1/2

STORAGE CABINET WORK AREA

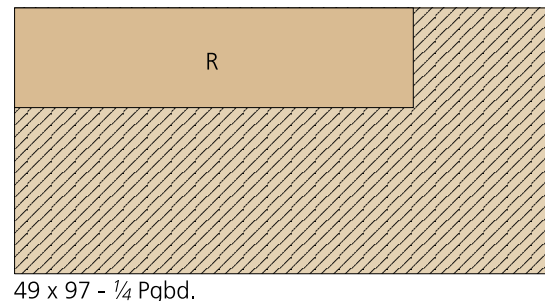
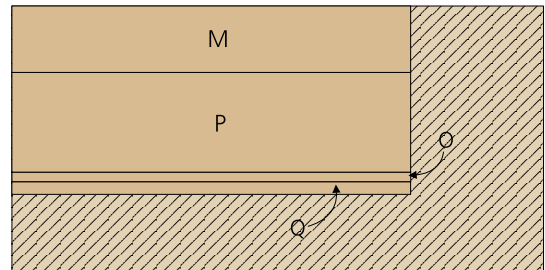
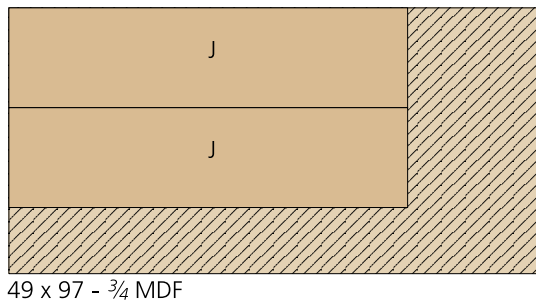
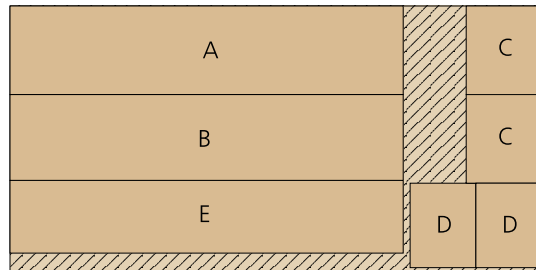
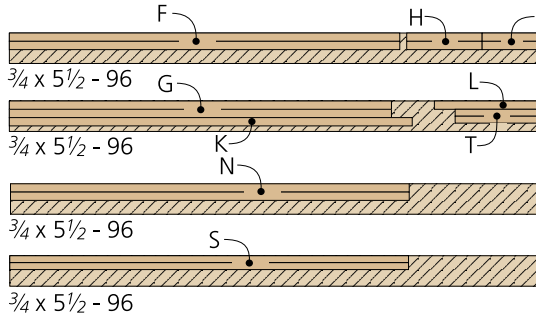

One-Wall Workshop

Materials

WORKBENCH AREA

U	Top	16 x 59 - 3/4 MDF
V	Bottom	15 1/2 x 59 - 3/4 MDF
W	Left/Right End (2)	13 5/8 x 16 - 3/4 MDF
X	Back	13 1/8 x 59 - 3/4 MDF
Y	Partitions (4)	11 7/8 x 15 1/4 - 3/4 MDF
Z	Top Supports (2)	11 3/8 x 18 1/4 - 3/4 MDF
AA	Face Frame Rail	3/4 x 1 1/2 - 57
BB	Face Frames Stiles (2)	3/4 x 1 1/2 - 13 5/8
CC	Tops (2)	18 1/2 x 60 - 3/4 MDF
DD	Front Edging	3/4 x 2 1/4 - 60
EE	Filler Strip	3/4 x 2 1/2 - 60
FF	Tops (2)	18 1/2 x 24 - 3/4 MDF
GG	Front Edging	3/4 x 1 1/2 - 24
HH	Top (3)	7 3/4 x 54 1/2 - 3/4 MDF
II	Rails (3)	3/4 x 2 1/4 - 54 1/2

JJ	Left/Right End (2)	3/4 x 2 1/4 - 12 1/4
KK	Vise Dog Run (3)	3/4 x 2 1/4 - 42
LL	Vise Guide Strips (2)	3/4 x 1/4 - 10
MM	Vise Traveler Block (3)	3/4 x 2 1/4 - 3
NN	Vise Mounting Block (3)	3/4 x 2 1/4 - 2 1/2
OO	Support Wedges (2)	3/4 x 1/2 - 9

WORKBENCH AREA

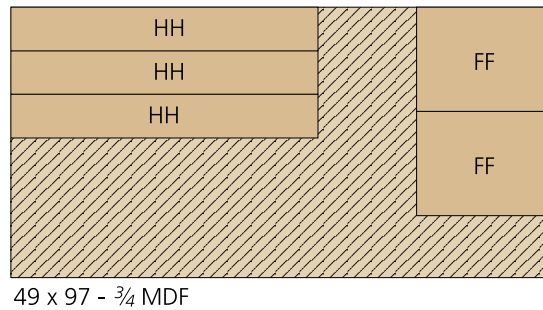
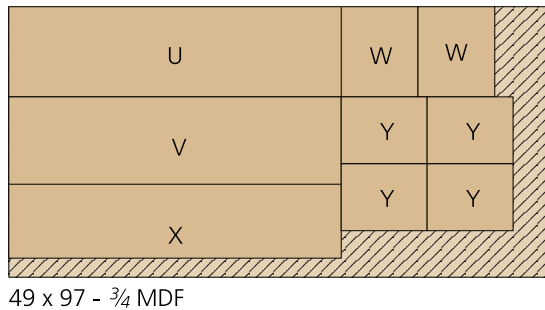
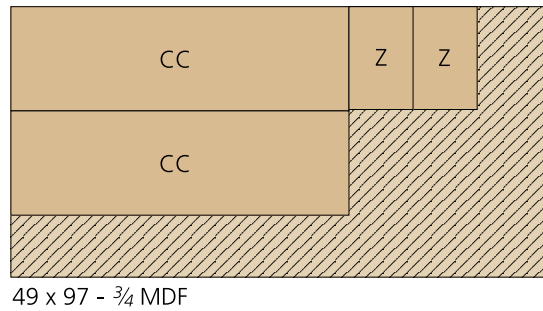
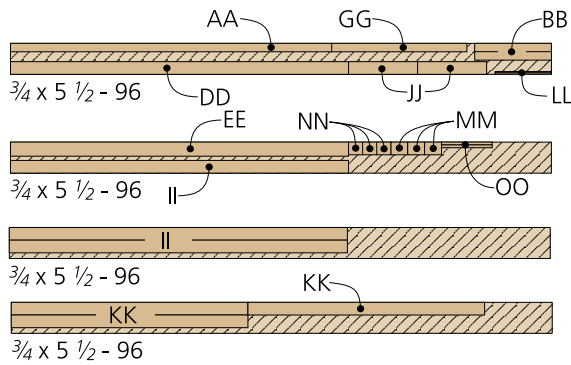

One-Wall Workshop

Materials

ADDITIONAL STORAGE

PP	Top	22½ x 24 - ¾ MDF	FFF	Top/Bottom Spacer (2)	¾ x 1¼ - 60
QQ	Sides (2)	2½ x 24 - ¾ MDF	GGG	End Spacers (2)	¾ x 1¼ - 15½
RR	Front Face	2½ x 23¾ - ¾ MDF	HHH	Shelves (2)	¾ x 5¾ - 22
SS	Flange (2)	3¼ x 24 - ¾ MDF	III	Back Panels (2)	¾ x 6 - 22
TT	Shelves (2)	7 x 59 - ¾ MDF	JJJ	Ends (4)	¾ x 6 - 6
UU	Front/Back Edging (4)	¾ x 1¼ - 60			
VV	End Edging (4)	¾ x 1¼ - 8			
WW	Bottom Panel	12 x 84 - ¾ MDF			
XX	Panel Blocking (2)	1 x 1½ - 84			
YY	Panel Edging	1¾ x 84 - ¾ MDF			
ZZ	Top Panel	18 x 84 - ¾ MDF			
AAA	Front Light Rail	2¼ x 84 - ¾ MDF			
BBB	Pegboard	18 x 24 - ¼ Pgbd.			
CCC	Top/Bottom Spacer (2)	¾ x 1¼ - 24			
DDD	End Spacers (2)	¾ x 1¼ - 15½			
EEE	Pegboard	18 x 60 - ¼ Pgbd.			

ADDITIONAL STORAGE

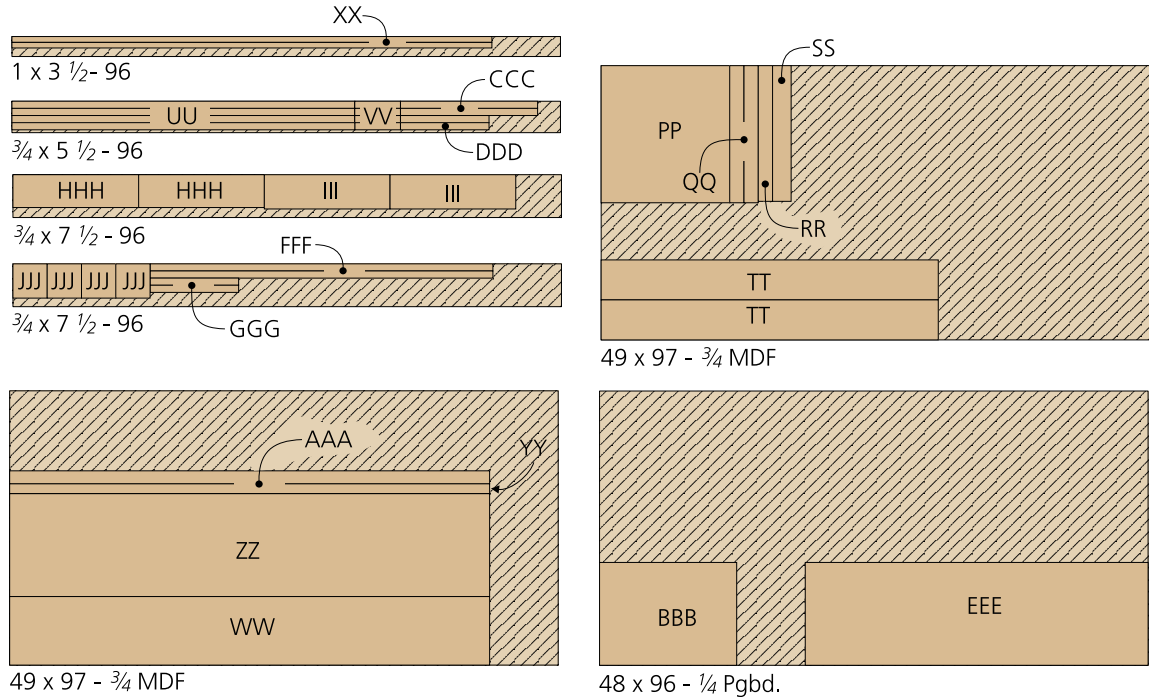

NOTE: IF BUILDING THE ENTIRE ONE-WALL WORKSHOP, SHEET GOOD PARTS CAN BE COMBINED TO MINIMIZE SHEET REQUIREMENTS